

Electromagnetic Compatibility (EMC)

General

The aim of electromagnetic compatibility considerations is to avoid or minimize the influence of electromagnetic phenomena on a device, equipment or system and on living or inert matter. To achieve this, methods of measurement and test, as well as limits and levels of electromagnetic emission and of electromagnetic immunity are defined in a large number of EMC publications.

Note: The European EMC Directive does not cover the interaction between technical apparatus and the biological environment.

Types of EMC Publications

EMC publications and standards, developed by the IEC and other standardization bodies, can be divided into four general categories:

Generic EMC Standards, Basic EMC Publications, Product family EMC Standards and Product EMC Standards. These terms are defined in the corresponding chapters below.

Product and Product Family EMC Standards take precedence over *Generic EMC Standards* and *Product EMC Standards* take precedence over *Product Family EMC Standards*.

The distinction between these four types of EMC publications is not yet consequently applied within the IEC, CISPR and Cenelec (EN).

Generic EMC Standards

Generic EMC Standards specify requirements for products and systems operating in residential or industrial environments. They apply to products for which no dedicated *Product Family EMC Standards* or *Product EMC Standards* exist.

Generic EMC Standards can be considered to be general *Product Standards* in that they specify a limited number of essential emission and immunity tests, maximum emission levels as well as minimum immunity test levels with assigned performance criteria but refer to the *Basic EMC Standards* for detailed measurement and test methods.

Table 1: *Generic EMC Emission Standards* (only parts relevant to power supplies)

| IEC 61000-6-3/EN 50081-1: Electromagnetic compatibility – Generic standards – Emission standard for residential, commercial and light-industrial environments | | IEC 61000-6-4/EN 50081-2: Electromagnetic compatibility – Generic standards – Emission standard for industrial environments | | |
|--|------------------------------|---|------------------------------|------------------------------------|
| Port | Referenced basic standard | Frequency range and required limit | Referenced basic standard | Frequency range and required limit |
| Case (radiated) | CISPR 22/ EN 55022 | 30...1000 MHz, class B | CISPR 11/ EN 55011 | 30...1000 MHz, Group 1, class A |
| AC mains (conducted) | | 0.15...30 MHz, class B | | 0.15...30 MHz, Group 1, class A |
| | IEC 61000-3-2/ EN 60555-2 | 0...2 kHz | | |
| | IEC 61000-3-3/ EN 60555-3 | 0...2 kHz | | |

Table 2: Generic EMC Immunity Standards (only parts relevant to power supplies)

| Referenced Basic standard | Port | Requirements of Generic Standard EN 50082-1 (IEC 61000-6-1): Electromagnetic compatibility – Generic standards – Immunity standard for residential, commercial and light-industrial environments | Requirements of Generic Standard IEC 61000-6-2/EN 50082-2: Electromagnetic compatibility – Generic standards – Immunity standard for industrial environments | Performance criterion |
|--|--------------------------|---|---|-----------------------|
| IEC/EN 61000-4-2: Electrostatic discharge | Enclosure (case) | ±4 kV contact discharge | ±4 kV contact discharge | B |
| | | ±8 kV air discharge | ±8 kV air discharge | |
| IEC/EN 61000-4-3/ ENV 50204: Electromagnetic field | Enclosure (case) | 3 V/m, 80...1000 MHz, AM 80%, 1 kHz, 900 MHz, PM 200 Hz ¹ | 10 V/m, 80...1000 MHz, AM 80%, 1 kHz, 900 MHz, PM 200 Hz ¹ | A |
| IEC/EN 61000-4-4: Fast transients (burst) | Signal and control | ±0.5 kV, 5 kHz, capacitive clamp (only if cables are longer than 3 m) | ±1 kV, 5 kHz, capacitive clamp (only if cables are longer than 3 m), ±2 kV, 5 kHz, capacitive clamp (only for process control and according to EN) | B |
| | DC input and output | ±0.5 kV, 5 kHz, direct injection (only if cables are longer than 10 m) | ±2 kV, 5 kHz, direct injection | |
| | AC input and output | ±1 kV, 5 kHz | | |
| IEC/EN 61000-4-5: Surges | DC input (and output) | ±0.5 kV line to earth, ±0.5 kV line to line | ±0.5 kV line to earth, ±0.5 kV line to line | |
| | AC input | ±2 kV line to earth, ±1 kV line to line | ±4 kV line to earth, ±2 kV line to line | |
| IEC/EN 61000-4-6: Common mode conducted disturbances | Signal and control lines | 3 V, 0.15...80 MHz, AM 80%, 1 kHz (only if cables are longer than 3 m) | 10 V, 0.15...80 MHz, AM 80%, 1 kHz (according to IEC only if cables are longer than 3 m) | A |
| | DC input and output | | | |
| | AC input and output | 3 V, 0.15...80 MHz, AM 80%, 1 kHz | 10 V, 0.15...80 MHz, AM 80%, 1 kHz | |
| IEC/EN 61000-4-11: Voltage dips | AC input | 30%, 10 ms | 30%, 0.5 periods | B |
| | | 60%, 100 ms | 60%, 5 and 50 periods | C |
| | | >95%, 5000 ms | >95%, 250 periods | |
| IEC/EN 61000-4-11: Voltage interruptions | | | | |

¹ 900 MHz is referenced in EN standards only.

Basic EMC Publications

Basic EMC Publications specify the general and fundamental conditions and rules as well as the measurement and testing techniques for the verification of EMC and serve as reference documents for the product committees of the standardization bodies. *Basic EMC Publications* relate to general information, to the disturbing phenomena and to measurement or testing techniques.

Basic EMC Publications are general standards or technical reports and are not dedicated to specific product families or products. They should not include prescribed limits and related performances. These are covered by the *Generic, Product Family or Product Standards*.

Basic Emission Standards

Electromagnetic emission is the phenomenon by which electromagnetic energy emanates from a source.

Radio Frequency Emission

Radio frequency emission, also called radio frequency interference (RFI) is an electromagnetic disturbance which is generated by electrical apparatus and can be received by other equipment.

In power supplies, the RFI is generated by the switching devices. The steeper the voltage steps and the higher the switching frequency, the greater the high frequency content of generated disturbances. These disturbances can couple to other components in the power supply, producing noise sources radiating over a broad frequency spectrum.

International basic emission standards are prepared by the CISPR (Comité international spécial des perturbations radioélectriques – International special committee on radio interference) and adopted by national or multinational authorities.

It is usual to measure disturbances at low frequencies (150 kHz up to approx. 30 MHz) as voltages between the supply lines and earth (conducted disturbances) and at higher frequencies (above approx. 30 MHz) as field strength or power (radiated disturbances).

The graphs below provide an overview of the most common international standards for both conducted and radiated emissions.

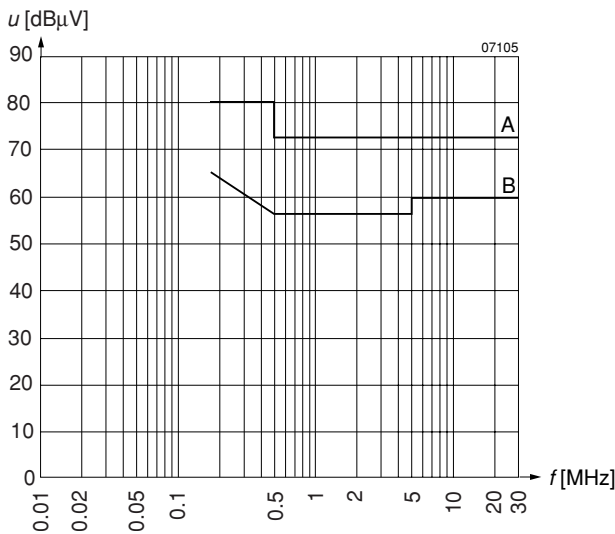

Fig. 1 Disturbance voltage limits (quasi-peak) according to CISPR 11/EN 55011 and CISPR 22/EN 55022

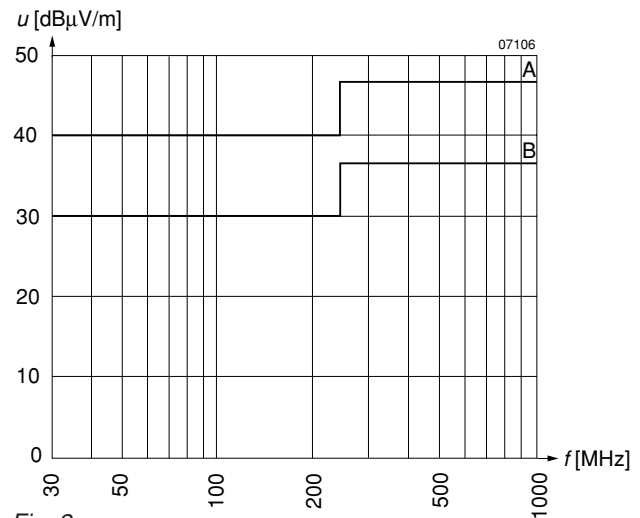

Fig. 2 Disturbance field strength limits (quasi-peak) according to CISPR 11/EN 55011 and CISPR 22/EN 55022, normalized to a distance of 10 m

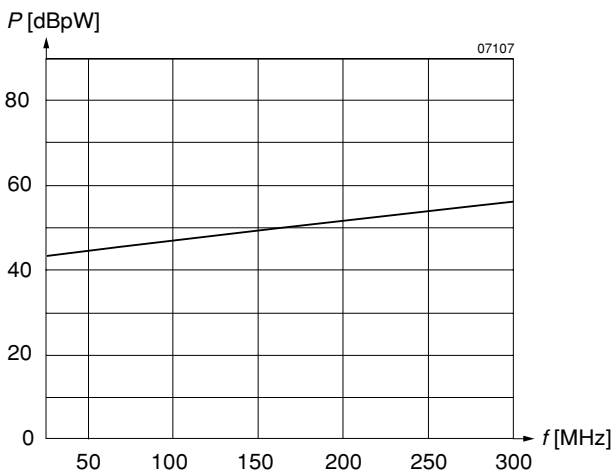

Fig. 3 Disturbance power limits (quasi-peak) according to CISPR 14/EN 55014

CISPR 11/EN 55011: Industrial, scientific and medical (ISM) radio-frequency equipment – Electromagnetic disturbance characteristics – Limits and methods of measurement

CISPR 14/EN 55014 (= VDE 0875, part 14): Limits and methods of measurement of radio disturbance characteristics of electric motor-operated and thermal appliances for household and similar purposes, electric tools and similar electric apparatus

This standard is not directly applicable to power supplies, but describes methods of measuring radiated electromagnetic power using an absorbing (MDS) clamp. The clamp allows the simple measurement over a cable of a defined length.

CISPR 22/EN 55022 (= VDE 0878, part 22; corresponds to FCC, part 15): Limits and methods of measurement of radio disturbance characteristics of information technology (IT) equipment

MIL-STD-461C: Electromagnetic emission and susceptibility requirements for the control of electromagnetic interference

Harmonic Current Emission

Electrical and electronic equipment inject harmonic currents into their AC supply system. In order to ensure electromagnetic compatibility, maximum harmonic disturbance levels have been defined in the corresponding standards.

cos φ

For undistorted, sinusoidal waveforms cos φ is the displacement factor of the load current compared to the mains voltage (fig. cos φ).

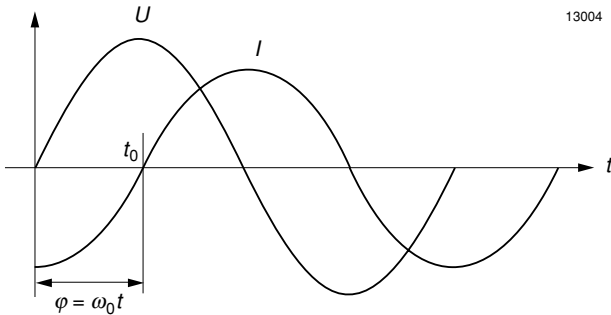

Fig. 4
cos φ

For this special case φ is also equal to the phase difference between true power and the apparent power.

Apparent power: $S = U_{rms} \cdot I_{rms}$
 True power: $P = U_{rms} \cdot I_{rms} \cdot \cos \varphi = S \cdot \cos \varphi$
 Reactive power: $Q = U_{rms} \cdot I_{rms} \cdot \sin \varphi$

Apparent power is the vector sum of the true and reactive power (fig. AC-power components).

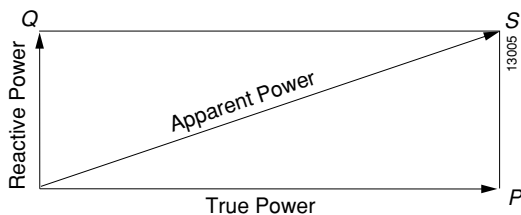

Fig. 5
AC-power components

Power Factor

For single phase systems the power factor is defined as the ratio of the true power delivered to the load to the apparent power. Power factor is the generalized case of cos φ, since the waveforms do not have to be sinusoidal. For the special case where the waveforms are sinusoidal, the power factor is equal to cos φ.

$$PF = \frac{\text{True power}}{\text{Apparent power}} = \frac{P}{S}$$

In practice the mains voltage can be assumed to be sinusoidal. So the power factor only depends on the distortion of the load current: The more the waveform is distorted, the lower the power factor. A perfect power factor would be equal to 1, whereas the worst case power factor is 0.

$$PF = \frac{I_0 \cdot \cos \varphi_0}{I_{rms}}$$

- I_0 : Fundamental of load current
- $\cos \varphi_0$: Displacement factor of fundamental of load current
- I_{rms} : rms-value of load current

Harmonic Distortion

For nonlinear loads (for example rectifier) the load current will not be sinusoidal anymore (fig. Harmonic distortion).

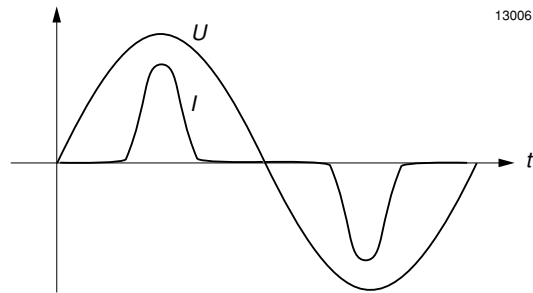

Fig. 6
Harmonic distortion

Since true power only takes place at the fundamental frequency (frequency of mains voltage), the analysis of the current into fundamental and harmonic currents has to be calculated (Fourier analysis):

$$I(t) = I_0 \cdot \sin(\omega_0 t + \varphi_0) + I_1 \cdot \sin(\omega_1 t + \varphi_1) + \dots + I_n \cdot \sin(\omega_n t + \varphi_n)$$

- I_0 : amplitude of fundamental
- I_i : amplitude of i^{th} harmonic
- $\omega_0 = 2 \pi \cdot f_0$ $f_0 = 50/60 \text{ Hz}$ frequency of fundamental
- $\omega_i = i \cdot \omega_0$ $i = 1 \dots n$ frequency of i^{th} harmonic
- φ_0 phase shift of fundamental
- φ_i $i = 1 \dots n$ phase shift of i^{th} harmonic

Based on this decomposition the Distortion Factor can be calculated:

$$K = \frac{\text{Contents of harmonics}}{\text{rms-value}}$$

$$K = \sqrt{\frac{\sum_{i=1}^{\infty} I_i^2}{\sum_{i=0}^{\infty} I_i^2}}$$

IEC/EN 61000-3-2: Limits for harmonic current emissions
(equipment input current ≤ 16 A per phase)

This standard deals with the limitation of harmonic currents injected into the public supply systems with nominal voltages of 220 V (line to neutral) or more. It is applicable to

equipment having an input current up to and including 16 A per phase. The standard defines 4 classes of equipment with different harmonic current limits:

| Class | Description | Limits | | Unit |
|-------|--|--------------------------------------|--------------------------------------|---|
| | | Harmonic order | Maximum permissible harmonic current | |
| A | Balanced three-phase equipment and all other equipment, except those included in one of the following classes. | 2 | 1.08 | A |
| | | 3 | 2.30 | |
| | | 4 | 0.43 | |
| | | 5 | 1.14 | |
| | | 6 | 0.30 | |
| | | 7...40 | 0.77...0.046 | |
| B | Portable tools | Limits of class A, multiplied by 1.5 | | |
| C | Lighting equipment | 2 | 2 | % of input current at the fundamental frequency |
| | | 5 | 10 | |
| | | 7 | 7 | |
| | | 9 | 5 | |
| | | 11...39 (odd only) | 3 | |
| | | 3 | $30 \cdot \lambda$ | %; λ = circuit power factor |
| D | Equipment having an input current with a "special wave shape" (as defined in the standard) and an active input power above 75 W up to 600 W. | 3 | 3.4 | mA/W |
| | | 5 | 1.9 | |
| | | 7 | 1.0 | |
| | | 9 | 0.5 | |
| | | 11...39 (odd only) | 0.35...0.1 | |

Power-One power supplies which don't supply portable tools or lightning equipment are deemed to be class A if they provide an active power factor correction circuit or

have an active input power above 600 W, otherwise they are class D. The lower active power limit for class D equipment will be reduced from 75 W to 50 W.

Basic Immunity (Susceptibility) Standards

Electromagnetic immunity is the ability of a device, equipment or system to perform without degradation in the presence of electromagnetic disturbances. Electromagnetic susceptibility is the inability to perform without degradation, i.e. susceptibility is the lack of immunity.

The aim of basic immunity standards is to provide test procedures and test levels to verify electromagnetic immunity. Both conducted and radiated phenomena are considered. The results of tests are classified in terms of the loss of function or degradation of performance of the equipment under test as follows:

Performance Criteria

A Normal performance within limits specified by the manufacturer.

Power-One specifies normal performance as the output voltage of a power supply not deviating by more than 3% from the value prior to the test.

B Temporary loss of function or degradation of performance which ceases after the disturbance ceases.

Power-One specifies degradation of performance as a voltage deviation of more than 3% from the value before the test.

C Temporary loss of function or degradation of performance, the correction of which requires operator intervention or system reset.

In case of Power-One power supplies, operator intervention can mean turning the unit off and on by removal and re-application of the input supply or by means of the inhibit input.

D Loss of function or degradation of performance which is not recoverable, due to damage of hardware or software or loss of data.

IEC/EN 61000-4-2: Electrostatic discharge (ESD) immunity test

Static electricity discharges may be present in environments with low relative humidity, using low-conductivity (artificial fibre) carpets, vinyl garments, etc.

This standard specifies requirements and tests for the immunity of electrical or electronic equipment which are subject to electrostatic discharge. The tests are based on a human body model with a capacitance of 150 pF and a discharge resistance of 330 Ω.

The discharge shall either be applied in direct contact or over a short air distance to parts of the device under test which can be touched by persons during normal use.

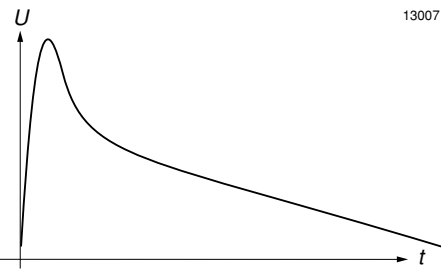

Fig. 7 Electrostatic discharge pulse

| Contact discharge | | | Air discharge | | |
|-------------------|-----------------|----------------|---------------|-----------------|----------------|
| Test level | Test voltage kV | Peak current A | Test level | Test voltage kV | Peak current A |
| 1 | 2 | 7.5 | 1 | 2 | 7.5 |
| 2 | 4 | 15 | 2 | 4 | 15 |
| 3 | 6 | 22.5 | 3 | 8 | 30 |
| 4 | 8 | 30 | 4 | 15 | 56 |
| x | special | | x | special | |

IEC/EN 61000-4-3: Radiated, radio-frequency, electromagnetic field immunity test

Most electronic equipment is affected by electromagnetic radiation which is generated by hand-held radio transceivers, fixed-station radio and television transmitters and various industrial electromagnetic sources.

The radiated immunity test is applicable to all products, where radio frequency fields are present.

The test is performed by applying an electromagnetic far field of defined strength while varying the frequency in the range 80...1000 MHz. The table gives the field strength of the unmodulated signal. For testing, this signal is 80% amplitude modulated with a 1 kHz sine wave.

| Test level | Test field strength V/m |
|------------|-------------------------|
| 1 | 1 |
| 2 | 3 |
| 3 | 10 |
| x | special |

ENV 50204: Radiated electromagnetic field from digital radio telephones – Immunity test

The radiated immunity test is applicable to all products, where radio frequency fields from digital radio telephones are present.

The test is performed by applying an electromagnetic far field of defined strength with a fixed frequency. Two different spot frequencies are defined: 900 ±5 MHz and 1890 ±10 MHz. The table gives the field strength of the unmodulated signal. For testing, this signal is pulse modulated with a duty cycle of 50% at a repetition frequency of 200 Hz.

This test is subject to be implemented in IEC/EN 61000-4-3.

| Test level | Test field strength V/m |
|------------|-------------------------|
| 1 | 1 |
| 2 | 3 |
| 3 | 10 |
| 4 | 30 |
| x | special |

IEC/EN 61000-4-4: Electrical fast transient/burst immunity test

The fast transients test is applicable to products which are connected to AC or DC power systems or have cables in close proximity to such sources. It is intended to demonstrate immunity to transient disturbances such as those originating from switching transients (interruption of inductive loads, relay contact bounce, etc.).

The waveform of a single transient is characterized by a rise time of 5 ns, a time to half-value of 50 ns and a maximum energy of 4 mJ at 2 kV into a 50 Ω load. The impedance of the transient source is 50 Ω. The repetition frequency of the transients is a function of the test level. Burst duration is 15 ms and burst period 300 ms. Coupling is performed via a coupling/decoupling network with coupling ca-

pacitors of 33 nF for power supply ports and via a capacitive coupling clamp with a capacitance of 50...200 pF for signal, data and control ports.

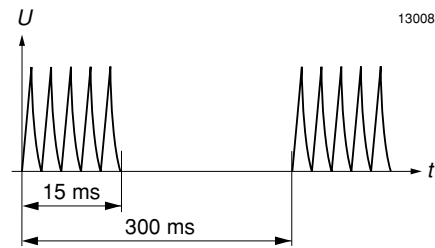

Fig. 8
Electrical fast transients/bursts

| Test level | On AC and DC power supply ports | | On signal, data and control ports | |
|------------|---------------------------------|--------------------------|-----------------------------------|--------------------------|
| | Open-circuit peak voltage kV | Repetition frequency kHz | Open-circuit peak voltage kV | Repetition frequency kHz |
| 1 | 0.5 | 5 | 0.25 | 5 |
| 2 | 1 | 5 | 0.5 | 5 |
| 3 | 2 | 5 | 1 | 5 |
| 4 | 4 | 2.5 | 2 | 5 |
| x | special | special | special | special |

IEC/EN 61000-4-5: Surge immunity test

Surges are mainly generated by switching transients or by lightning strokes injecting high currents producing voltages or inducing high voltages/currents via electromagnetic fields. Switching transients can be generated by power system switching, load changes, short circuits or arcing faults to the earthing system of the installation.

The surge immunity test is applicable to products, which are connected to mains supplies or other networks leaving the building. It is intended to demonstrate immunity to surge voltages caused by switching and lightning effects. It is not intended to test the capability of the insulation to withstand high-voltage stress.

The standard specifies two different open-circuit surge waveforms: One with a rise time of 1.2 μs and a time to half-value of 50 μs, and the other with a rise time of 10 μs and a time to half-value of 700 μs. The source impedance for the 1.2/50 μs surge, is 2 Ω for line to line coupling and 12 Ω for line to earth coupling. The 10/700 μs surge impedance is 42 Ω. Coupling for both waveforms is performed via a coupling/decoupling network with coupling capacitors of 0.1, 0.5, 9 or 18 μF, or with arrestors, depending on the kind of lines to be tested.

| Test level | Open circuit test voltage kV |
|------------|------------------------------|
| 1 | 0.5 |
| 2 | 1 |
| 3 | 2 |
| 4 | 4 |
| x | special |

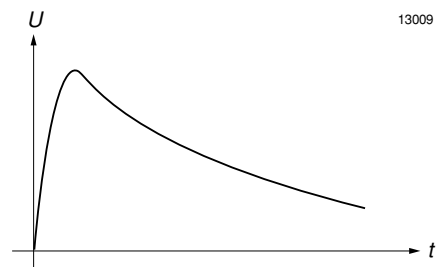

Fig. 9
Surge

IEC/EN 61000-4-6: Immunity to conducted disturbances, induced by radio-frequency fields

The source of conducted disturbances is basically an electromagnetic field, emanating from RF transmitters, that may act on the whole length of cables connected to installed equipment. The in-going and out-going leads behave as passive antenna networks if they are several wavelengths long.

The conducted immunity test is applicable to products operating in environments where radio frequency fields are present and which are connected to mains supplies or other networks (signal or control lines). This test is a supplement to IEC/EN 61000-4-3 which defines test methods for immunity to radiated electromagnetic energy.

The test is performed by applying a voltage of a defined value to the port to be tested while varying the frequency in the range 150 kHz...80 MHz. The signal is 80% amplitude modulated with a 1 kHz sinewave. The table gives the field strength of the unmodulated signal. The impedance of the test generator is 50 Ω. The waveform is coupled to each of the n lines of the port to be tested (common mode) via a coupling/decoupling device with an impedance of n • 100 Ω per line or via an injection clamp.

| Test level | Open circuit test voltage (rms) | |
|------------|---------------------------------|---------|
| | V | dB (μV) |
| 1 | 1 | 120 |
| 2 | 3 | 130 |
| 3 | 10 | 140 |
| x | special | special |

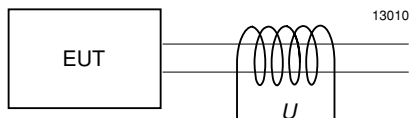

Fig. 10
Testing of immunity to conducted disturbances with injection clamp

IEC/EN 61000-4-8: Power frequency magnetic field immunity test

The power frequency magnetic field is mainly generated by power frequency currents in conductors.

In general this test is limited to products which are susceptible to magnetic fields (e.g. hall effect devices, CRTs and special products to be installed in high magnetic field environments). It has no relevance to power supplies.

The test is performed by applying a 50 or 60 Hz magnetic field of a defined strength to the equipment to be tested.

| Continuous | | Short duration (1...3 s) | |
|------------|-----------------------------------|--------------------------|-----------------------------------|
| Test level | Magnetic field strength A/m (rms) | Test level | Magnetic field strength A/m (rms) |
| 1 | 1 | 1 | not defined |
| 2 | 3 | 2 | not defined |
| 3 | 10 | 3 | not defined |
| 4 | 30 | 4 | 300 |
| 5 | 100 | 5 | 1000 |
| x | special | x | special |

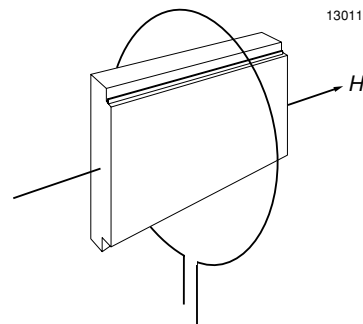

Fig. 11
Testing with power frequency magnetic field

IEC/EN 61000-4-9: Pulse magnetic field immunity test

Pulse magnetic fields are generated by lightning strokes on buildings and metal structures including aerial masts, earth conductors and earth networks and by initial fault transients in low voltage, medium voltage and high voltage systems.

This test is mainly applicable to products to be installed in electrical power plants (e.g. telecontrol centres in close proximity to switchgear). It is not relevant for distribution network equipment.

The test is performed by applying 6.4/16 μ s magnetic field pulses of defined strength to the equipment to be tested.

| Test level | Pulse magnetic field strength A/m (peak) |
|------------|--|
| 1 | not defined |
| 2 | not defined |
| 3 | 100 |
| 4 | 300 |
| 5 | 1000 |
| x | special |

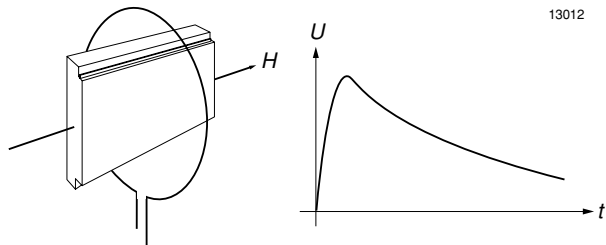

Fig. 12
Testing with pulse magnetic field

IEC/EN 61000-4-10: Damped oscillatory magnetic field immunity test

The damped oscillatory magnetic field is generated by the switching of high voltage bus-bars by isolators.

This test is mainly applicable to products to be installed in high voltage substations.

The test is performed by applying damped oscillatory magnetic field (sinusoid waves) of defined strength to the equipment to be tested.

| Waveform specification | "Low frequency" | "High frequency" |
|------------------------|---|------------------|
| Oscillation frequency | 0.1 MHz | 1 MHz |
| Decay rate | 50% of the peak value after 3 to 6 cycles | |
| Repetition rate | ≥ 40 Hz | ≥ 400 Hz |
| Test duration | 2 s | 2 s |

| Test level | Damped oscillatory magnetic field strength A/m (peak) |
|------------|---|
| 1 | not defined |
| 2 | not defined |
| 3 | 10 |
| 4 | 30 |
| 5 | 100 |
| x | special |

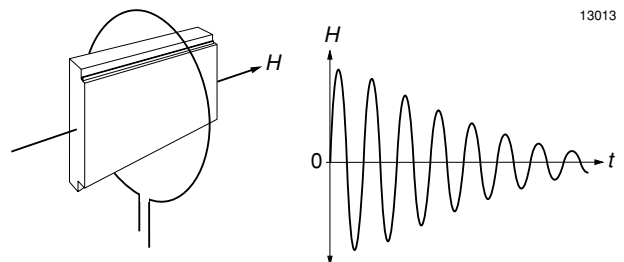

Fig. 13
Testing with damped oscillatory magnetic field

IEC/EN 61000-4-11: Voltage dips, short interruptions and voltage variations immunity tests

Voltage dips and short interruptions are caused by faults in the network or in installations or by a sudden large change of load. Voltage variations are caused by the continuously varying loads connected to the network.

These tests are applicable to equipment connected to AC mains with rated input currents not exceeding 16 A per phase.

The test for immunity to voltage dips and short interruptions is performed by an abrupt change of the supply voltage of the equipment under test at any phase angle on the mains voltage at the lower and at the upper voltage of the nominal voltage range.

For power supplies, immunity to these phenomenon can normally be derived from the specifications of input voltage range and hold-up time.

Preferred test levels and duration for voltage dips and short interruptions

| Test level in % of rated voltage for the equipment under test | Corresponding voltage change in % of rated voltage for the equipment under test | Duration in number of periods. Any duration may apply to any test level. |
|---|---|--|
| 0 | 100 | 0.5, 1, 5, 10, 25, 50, x (special) |
| 40 | 60 | |
| 70 | 30 | |

The test for immunity to voltage variations is optional. It specifies a defined transition between the lower and upper voltage of the nominal voltage range and the changed voltage.

Timing of short-term supply voltage variations

| Test level in % of rated voltage for the equipment under test | Time for decreasing the voltage in s | Time at reduced voltage in s | Time for increasing the voltage in s |
|---|--------------------------------------|------------------------------|--------------------------------------|
| 40 | 2 ±20% | 1 ±20% | 2 ±20% |
| 0 | 2 ±20% | 1 ±20% | 2 ±20% |
| 40 | x (special) | x (special) | x (special) |
| 0 | x (special) | x (special) | x (special) |

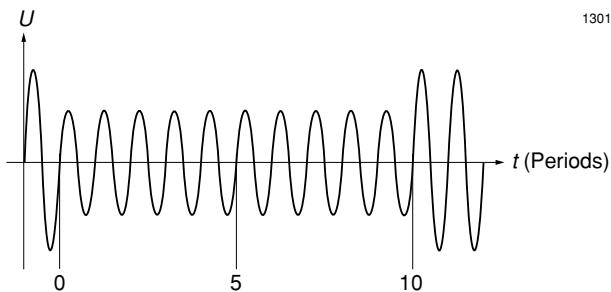

Fig. 14
Voltage dips

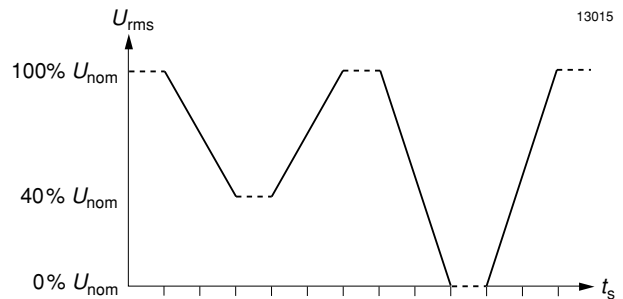

Fig. 15
Voltage variations

IEC/EN 61000-4-12: Oscillatory waves immunity test

This standard specifies tests to simulate two phenomena:

The ring wave (non-repetitive) appears at the terminals of equipment as a consequence of switching in power and control lines, as well as a consequence of lightning. The ring wave test is applicable to equipment connected to AC mains in certain countries (e.g. the mains network in the USA). This test has existed for a long time under the designation ANSI/IEEE C.62.41-1991.

The damped oscillatory wave (repetitive) appears at the terminals of equipment as a consequence of switching with restriking of the arc. The damped oscillatory wave test is applicable to equipment used in high voltage substations

(static relays). This test, but with a frequency of 1 MHz only, has existed for a long time under IEC 255-4, appendix E5: *High frequency disturbance test*, also known as ANSI/IEEE C.37.90a-1989, and has been transferred to IEC 60255-22-1: *Electrical disturbance tests for measuring relays and protection equipment – 1 MHz burst disturbance tests*. By inclusion in IEC 61000-4-12 the frequency range was extended.

Coupling is performed via a coupling/decoupling network with coupling capacitors of 0.5, 3 or 10 μF , depending on the output impedance of the test generator.

| Wave specification | Ring wave | Damped oscillatory wave |
|--|--|---|
| Open circuit peak voltage | 250 to 4000 V | 250 to 2500 V |
| Oscillation frequency | 100 kHz | 100 kHz and 1 MHz |
| Decay rate | 60% of the preceding peak value | 50% of the peak value between the third and sixth periods |
| Repetition rate | 1 to 60 per minute | ≥ 40 Hz for 100 kHz and ≥ 400 Hz for 1 MHz |
| Output impedance | 12 Ω , 30 Ω and 200 Ω | 200 Ω |
| Coupling mode | Common mode and differential mode | Common mode and differential mode |
| Test duration per port and coupling mode | ≥ 5 positive and ≥ 5 negative transients | ≥ 2 s |

| Test level | Ring wave voltage kV (peak) | | Damped oscillatory wave voltage kV (peak) | |
|------------|-----------------------------|-------------------|---|-------------------|
| | Common mode | Differential mode | Common mode | Differential mode |
| 1 | 0.5 | 0.25 | 0.5 | 0.25 |
| 2 | 1 | 0.5 | 1 | 0.5 |
| 3 | 2 | 1 | 2 | 1 |
| 4 | 4 | 2 | - | - |
| x | special | special | special | special |

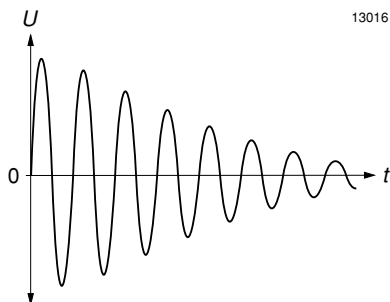

Fig. 16
Damped oscillatory wave

Product Family EMC Standards

A product family is a group of similar products for which the same standards can be applied. *Product Family EMC Standards* define specific electromagnetic (EM) requirements and test procedures dedicated to particular product families. They also give precise performance criteria taking into account the purpose of the equipment where possible. They apply the *Basic Standards* and coordinate with the *Generic Standards* to the extent practicable. Applicable *Product Family EMC Standards* take precedence over *Generic Standards*.

Product EMC Standards

Product EMC Standards relate to a particular type of product for which product specific requirements should be considered. Applicable *Product EMC Standards* take precedence over *Generic Standards* and *Product Family EMC Standards*.