

**FLYBACK CONVERTERS WITH L6561 PFC CONTROLLER**

by C. Adragna and G. Gattavari

The L6561, controller specifically designed for Power Factor Correction (PFC) circuits, may be successfully used in flyback converters as well.

The excellent performance of the device, along with its characteristics in terms of low current consumption, makes L6561-based flyback converters really attractive in medium-low power applications.

There are basically three different configurations that an L6561-based flyback converter can assume, each of them with its own characteristics, benefits and peculiarities. This paper describes these configurations and highlights advantages/drawbacks with the aim of identifying the most suitable applications they can fit.

**Introduction.**

Common practice bounds their use in conventional boost PFC stages, yet Transition Mode (TM) Power Factor Corrector IC's can be used in applications different from those they are primarily intended for.

This is particularly true for the L6561, PFC controller for medium-low power applications, because of its peculiar characteristics.

Reference [2] presents a special example showing how to extend the use of this device to Mag Amp applications.

Figure 1 - L6561 Internal Block Diagram

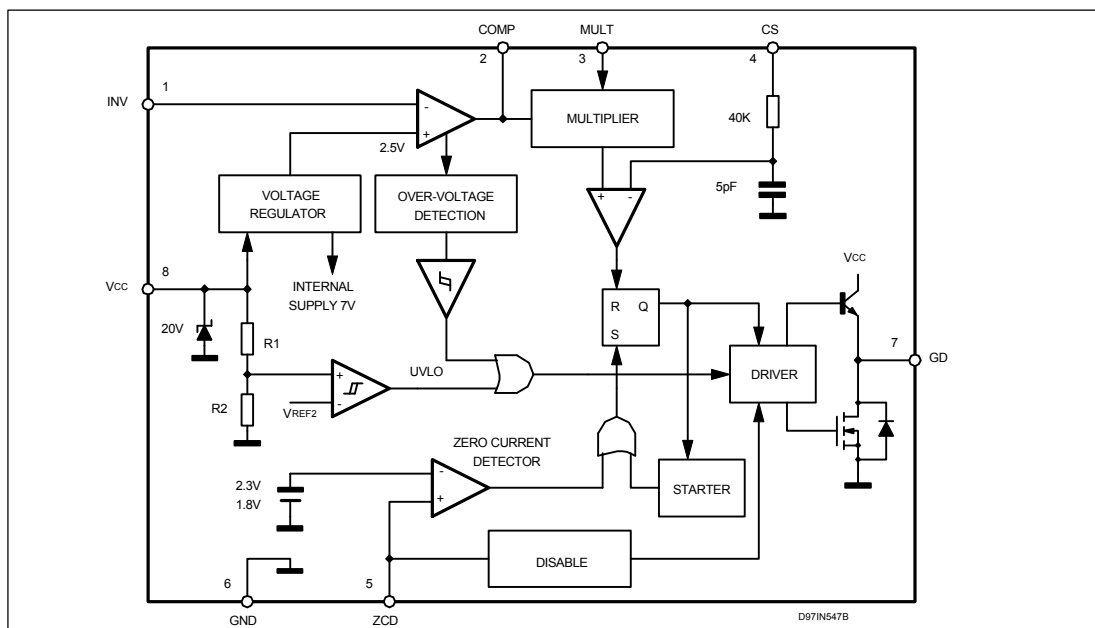

The outperforming L6561 offers a number of unique advantages that make the device an interesting alternative to the traditionally used PWM controllers where quite a good performance is required at low cost:

- disable function for power management and/or protection schemes;
- true micropower start-up current, 50  $\mu$ A typ., for cost-effective start-up circuits;
- very low quiescent current, 3 mA typ., for high efficiency at light load;
- two-level (static and dynamic) overvoltage protection (OVP);
- on-chip RC filter on current sense pin for improved noise immunity;
- pulse-by-pulse current limiting. In conjunction with TM operation, this ensures a safe operation under short circuit conditions.

Refer to [1] for a detailed explanation of the internal architecture (shown in fig. 1) and the functionality of the device.

L6561-based flyback converters can be realised as schematically illustrated in fig. 2a, 2b, 2c, and which will be referred to as "TM", "Synchronised" and "High-PF" respectively.

Figure 2 - L6561-based flyback converter configurations

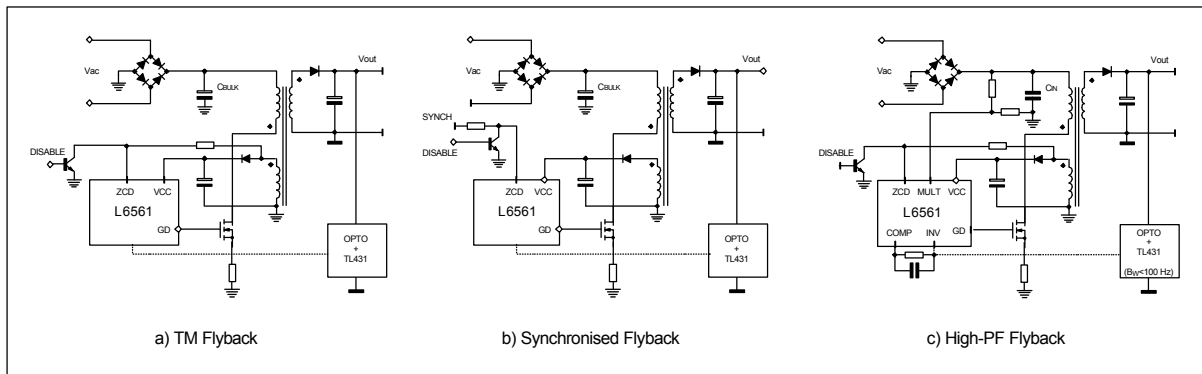

Each of them has its own peculiarities but they all share some key points:

- low parts count, which helps reduce total cost and space;
- high efficiency at very light load: an L6561-based flyback can be easily compliant with Blue Angel standards;
- standby function: the internal start-up timer may be used to make the system work at a (fixed) low frequency under light load conditions, so as to minimise losses;
- disable function: pin ZCD, if grounded, turns off the L6561 and reduce its consumption at a couple of mA; this can be used either for power management or protection.

In the following, the three basic configurations will be taken into consideration and their advantages, benefits and drawbacks will be highlighted so as to identify their most appropriate field of application. This will be made easier by some application examples.

### TM Flyback

This configuration, very similar to a free-running flyback always works on (very close to) the boundary between Continuous and Discontinuous Mode (i.e. Transition Mode, or TM), therefore at a frequency dependent on the input voltage and on the output current.

This type of operation requires a low inductance and therefore a small-size magnetics but on the other hand, involves high peak current. Therefore it can be reasonably used for power levels up to 50-60 W in 110 V or wide-range mains applications, and up to 100 W with 220/240 V mains.

At high input voltage and especially at light load, the switch ON-time becomes very short and the switching frequency tends to become quite high. There is, however, a minimum ON-time (0.4-0.5  $\mu$ s) below which it is not possible to go. This is due to the internal delay of the L6561 as well as the turn-off delay of the MOSFET.

When this minimum is reached, TM operation can no longer be kept. The energy drawn each cycle exceeds the short-term demand from the load and the control loop will delay MOSFET's turn-on so as to maintain the long-term energy balance. Switching becomes asynchronous, and this can be seen as a "ghosting" of the waveform on the scope.

If the load is decreased further on, the OVP of the L6561 will be triggered at last because the output voltage will tend to drift unregulated high. Under this condition, the system will operate in "burst" mode: there will be short periods of switching spaced out by long intervals where L6561's OVP keeps the switch in OFF state.

Fig. 3 shows a 7W power supply, realised in TM flyback. It is intended as an auxiliary power supply suitable for systems provided with power management, such as monitor displays, printers, servers, photocopiers, fax machines, etc.

According to an approach that is becoming more and more popular, when the system is requested to go into some low-consumption mode, the  $\mu$ P switches off the main SMPS. A small auxiliary supply, optimised for a low power level, keeps alive the  $\mu$ P itself and the circuits needed for waking up the system again. This approach allows to minimise the power consumption from the mains, in compliance with regulations coming into force (such as Blue Angel and others).

Figure 3 - 7W, Wide-range, Auxiliary Power Supply.

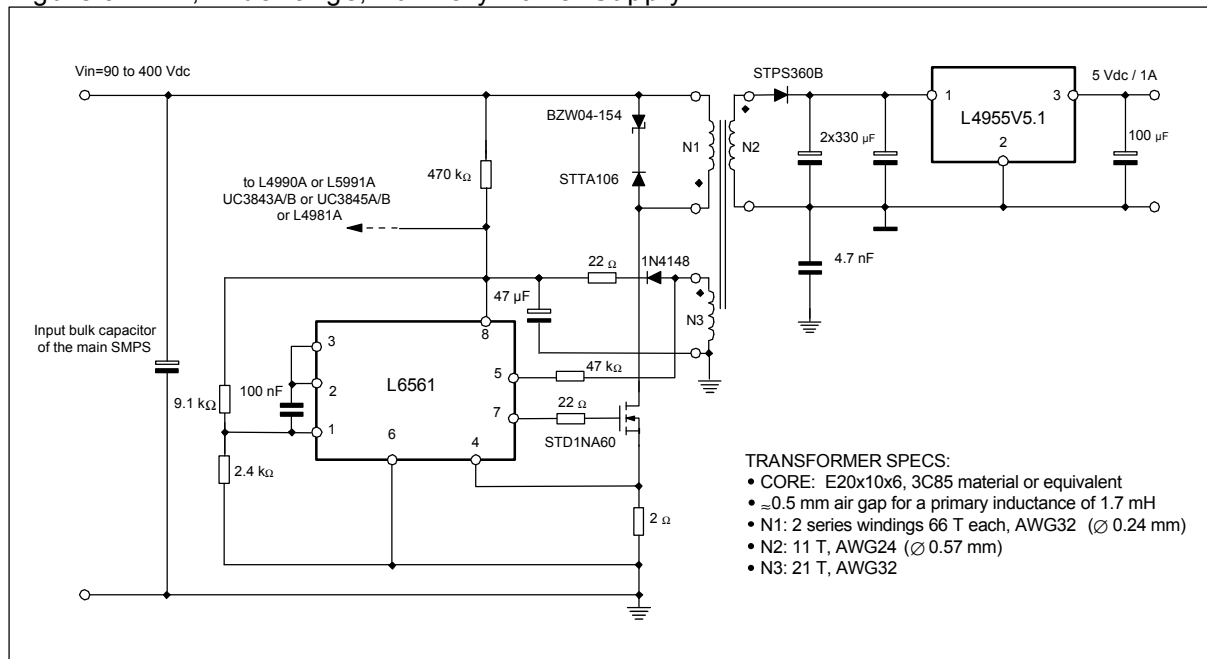

The converter is powered by the high-voltage DC bus, ranging from 90 to 400 VDC, generated by the front-end AC-DC stage (bridge rectifier + input capacitor) shared with the main SMPS (power factor corrected or not).

The output is post-regulated in order to provide a better regulation and supplies the  $\mu$ P as well as the logic circuit needed to wake up the system.

The auxiliary winding will be properly designed so as to supply the controller(s) of the main SMPS besides powering the L6561. To minimise component count, a primary sensing feedback technique is used.

The auxiliary winding is used also by the ZCD circuit for detecting transformer's full demagnetisation and turning on the MOSFET to start a new switching cycle (TM operation). The resistor driving the ZCD pin is in the ten k $\Omega$  but can be optimised so as to achieve a "quasi zero-voltage turn-on" as described in Ref. [1]. The optimum value depends mainly on the inductance of transformer's primary winding and on the  $C_{oss}$  of the power MOSFET, thus it can be found empirically after bench tests.

With the component values shown in fig. 3 the wake-up time of the converter, that is the time the system takes to start operating after being powered, does not exceed 3 s at 90 VDC supply and 1 s at 400 VDC.

In fig. 4, the circuit of fig. 3 is proposed with a different power rating: 15W output power so as to be able to support USB function in computer equipment. The modifications concern the MOSFET, the transformer and the sense resistor on the primary side, the catch diode and the filter capacitors on the secondary side. They all have been increased in size.

Figure 4 - 15W, Wide-range, Auxiliary Power Supply supporting USB function

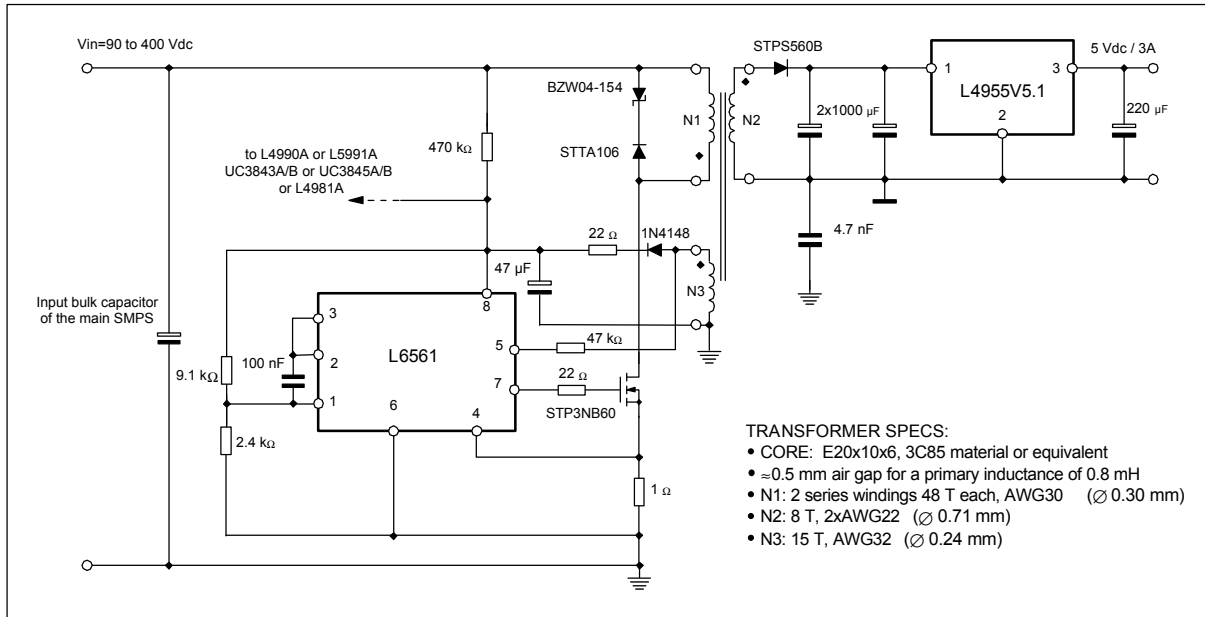
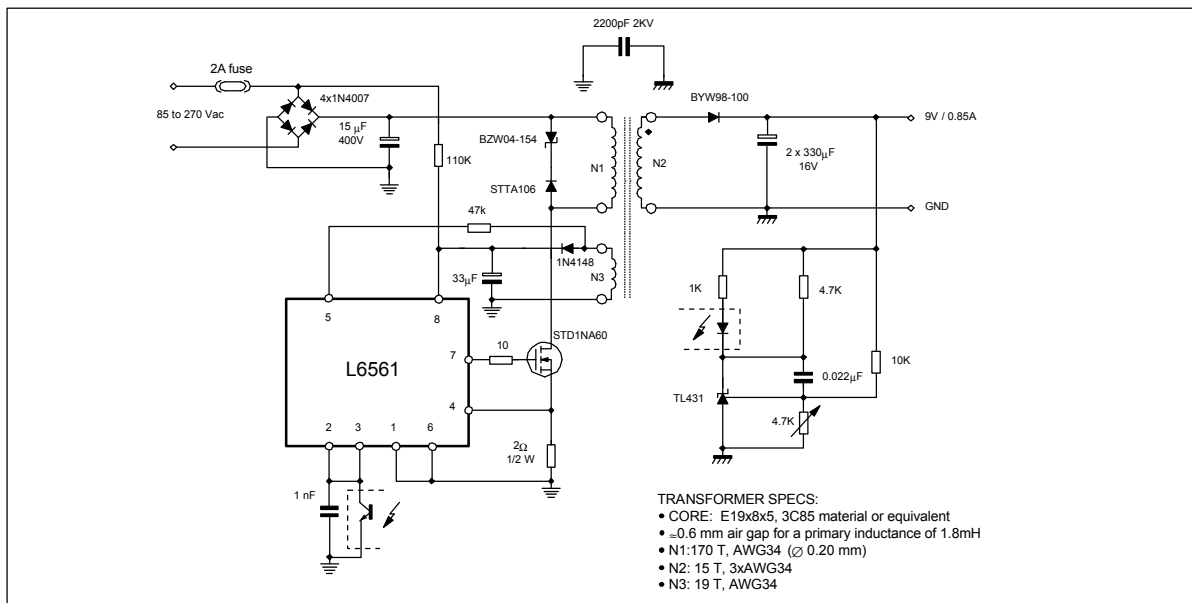

Fig. 5 shows another example of low-power TM flyback application, an AC-DC adapter for battery charger of cellular phones. The system looks very simple and very few parts are required.

The feedback uses a popular arrangement making use of a TL431 as secondary reference/error amplifier and of an optocoupler for transferring the control signal to the primary side. This provides very good regulation of the output voltage and galvanic isolation from the primary side at the same time.

The self-supply winding both powers the L6561 and provides transformer's demagnetisation signal to the ZCD pin. The start-up circuit arrangement and its component values ensures that the wake-up time of the converter does not exceed 3 s at 90 VAC supply (it will be less than 1 s at 270 VAC).

Figure 5 - 7.5 W, Wide-range Mains AC-DC Adapter for cellular phones.



In fig. 6 an example of multi-output SMPS for inkjet printer is presented. The converter accepts input voltages from 85 to 270 Vac and is rated for 40W output power. The 28V output is used for motors, the 12V output for the printhead and the 5V bus supplies the logic circuitry.

The isolated feedback is realised with the configuration TL431 + optocoupler. Output cross-regulation is improved by multiple sensing technique.

The system works in TM but can be forced to work at fixed frequency (that of L6561's internal timer) for minimum consumption at light load by the STANDBY signal (see fig. 6). This signal can be generated by either the  $\mu\text{P}$  or a current sense circuit that enables low (fixed) frequency operation when the load current falls below a defined threshold. To achieve this functionality, the ZCD pin is connected to ground through a 4.3 k $\Omega$  resistor.

Figure 6 - 40W, Wide-range Mains SMPS for Inkjet Printer.

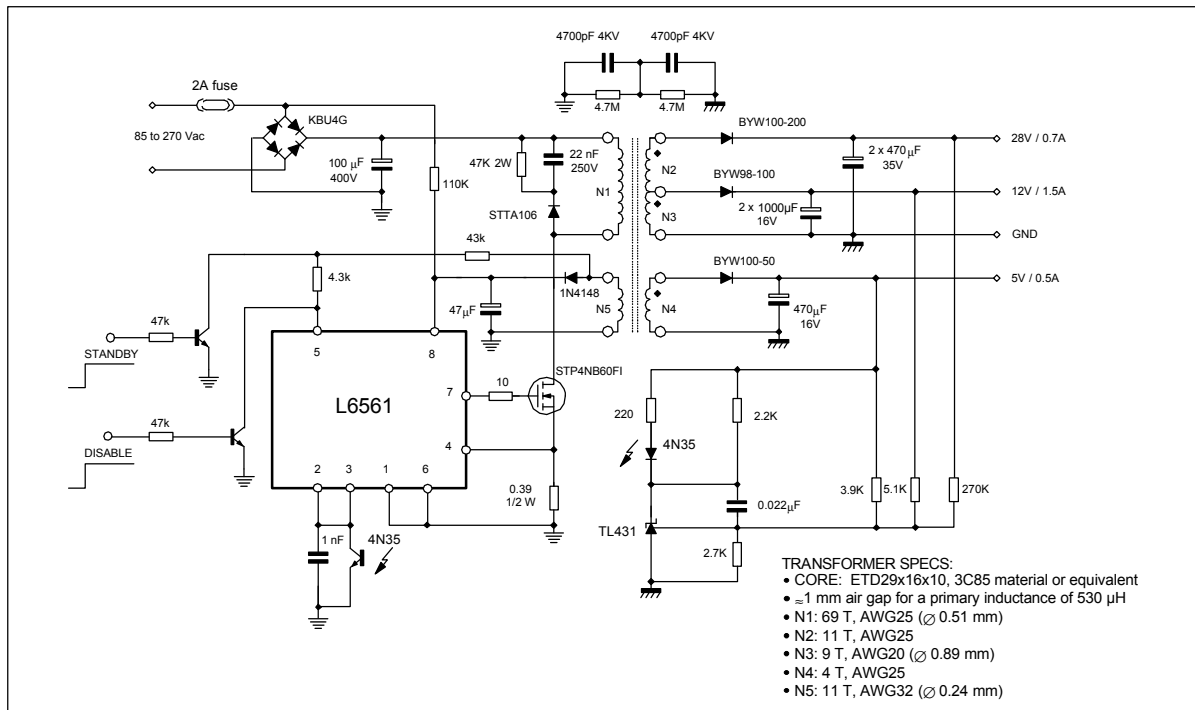

By directly grounding the ZCD pin, the converter will instead be shut down (DISABLE signal). This can be used for either power management (an auxiliary supply like the one of fig. 3 will keep the  $\mu\text{P}$  alive) or for protection, for example in case of overcurrent.

Not-latched overvoltage protection is available on-board in the L6561. Only the "static" protection (see Ref [1] for details) is here used since the feedback loop is fast. Pulse-by-pulse current limitation, inherent in the L6561, prevents input peak current from reaching too high values. TM operation keeps pulse-by-pulse current limiting effective even under short circuit conditions and ensures that the transformer will never saturate.

### Synchronised Flyback

L6561's ZCD pin is intended for triggering MOSFET's turn-on as the transformer is demagnetised, so as to achieve TM operation. In this configuration the ZCD pin is used instead as a synchronisation input and is driven by an external signal at a fixed frequency. This converter will then be exactly equal to a synchronised flyback based on available standard current mode controllers.

A typical application of such a configuration is in multisynch monitors, where a synchronisation signal coming from the horizontal deflection circuits of the display locks SMPS' switching frequency so as to improve noise immunity.

An example of 17" multisynch monitor SMPS with the L6561 is shown in fig. 7. Capable of working with wide-range mains, it is sized for 90W output power and can be synchronised from 31 to 82 kHz.

The primary side is extremely simple, yet the system features a number of functions needed in these systems, such as overvoltage protection (not-latched), overcurrent protection and synchronisation. There is also a protection against feedback disconnection (the zener diode between the supply voltage and L6561's pin 1).

Figure 7 - 90W, Wide-range Mains SMPS for Multisynch Monitors.

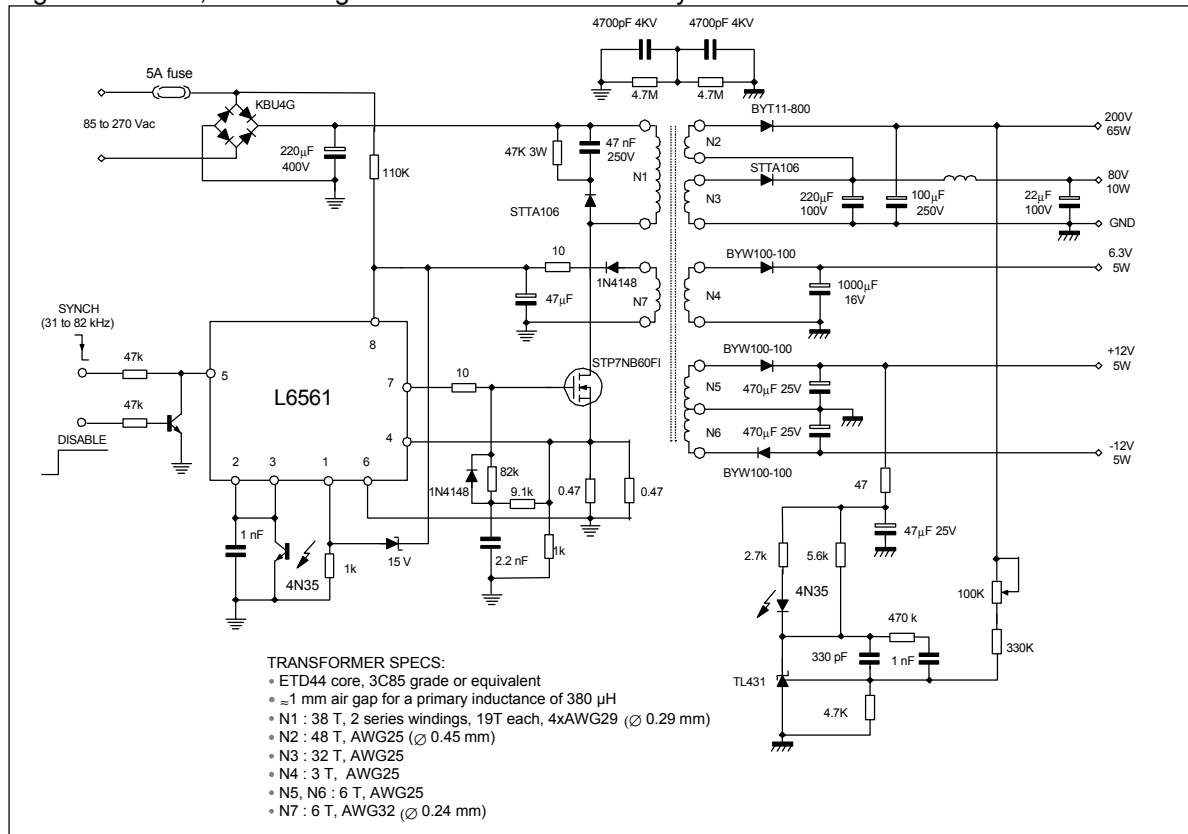

In addition, a disable function is always available, which can be used for any purpose the designer may require.

Since the system will work in Continuous Conduction Mode, especially at high switching frequency, a slope compensation circuit has been added to prevent subharmonic oscillation at duty cycles greater than 50%.

Compared to the circuitry needed for a standard controller, the synchronisation interface is much simpler: just one resistor. Furthermore, when the synchronisation signal is missing, the system will run at the frequency of the internal start-up timer (<15 kHz), which is lower than the minimum horizontal frequency. Under this conditions the power demanded by the monitor circuits is usually very low, and the system will go on working properly. This automatic functionality is extremely useful for minimising power consumption from the mains, again with the aim of meeting the relevant regulations.

### High-PF Flyback.

This configuration works in Transition Mode too but quite differently from the TM flyback previously discussed. The input capacitance is here so small that the input voltage is very close to a rectified sine wave. Besides, the control loop has a narrow bandwidth so as to be little sensitive to the twice mains frequency ripple appearing at the output. Ultimately, it is a PFC stage realised in flyback topology, rather than in boost topology as usual.

Actually, the high power factor (PF) exhibited by this topology can be considered just as an additional benefit but not the main reason that makes this configuration attractive. In fact, despite a PF greater than 0.9 can be easily achieved, it is a real challenge to comply with EMC norms regarding THD of line current, especially in universal mains applications. There are, however, several applications in the low-power range (to which EMC norms do not apply) that can benefit from the advantages offered by a high-PF flyback converter.

For a given power rating, the input capacitance can be 200 times less, compared to a conventional flyback. The bulky and costly high voltage electrolytic capacitor located after the bridge rectifier is replaced by a smaller low-cost film capacitor, with a considerable cut of cost and space.

Efficiency is high at heavy load, more than 90% is achievable: TM operation ensures low turn-on losses in the MOSFET and the high PF reduces dissipation in the bridge rectifier. This, in turn, minimises the requirements on the heatsink.

A few drawbacks, however, limit the applications that the high-PF flyback can fit (AC-DC adapters, battery chargers, low-power SMPS, etc.) and which one has to be aware of.

Because of the small input capacitance, the system is unable to cope with line missing cycles at heavy load. Like in boost PFC stages, the transient response to step-load changes is poor: as to this point, speeding up the control loop may lead to a compromise between an acceptable transient response and a reasonably high PF.

The output voltage exhibits a considerable twice-mains-frequency ripple, unavoidable if a high PF is desired. Speeding up the control loop may lead to a compromise between a reasonably low output ripple and a reasonably high PF. To keep the ripple low, a large output capacitance (in the thousand  $\mu\text{F}$ ) is anyway required: however, cheap standard capacitors and not costly high-quality parts are needed. In fact, a low ESR and an adequate AC current capability are automatically achieved with so large a capacitance. Besides, in conventional flyback converters there is usually plenty of output capacitance too, thus this is not so dramatic as it may seem.

Figure 8 - 30W, Wide-range Mains, High-PF, AC-DC Adapter.

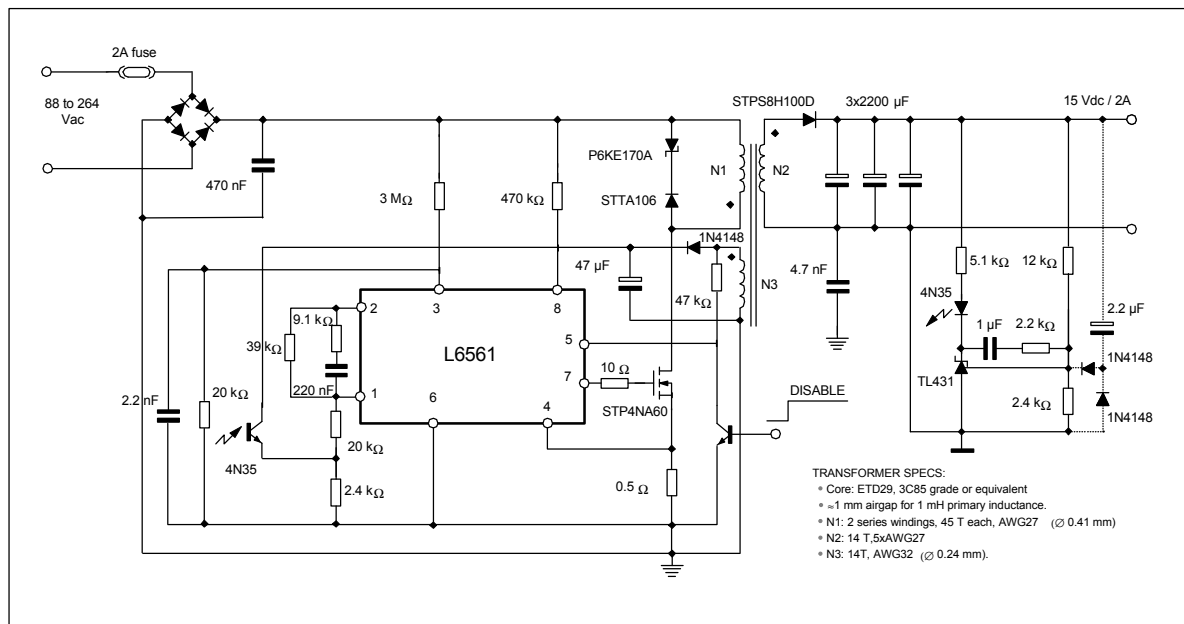

As a result, secondary post-regulation will be required where tight specifications on the output ripple and/or on the transient behaviour are given. This is true but is also what happens in numerous applications with a conventional flyback.

Please refer to Ref. [3] for a detailed explanation of the design of this kind of converter.

Fig. 8 shows the electrical schematic of a 30W AC-DC adapter based on high-PF flyback concept. It accepts universal mains and delivers 15V DC, 2A max. with a peak-to-peak twice mains frequency ripple below 1V.

The multiplier is biased with a partition of the input voltage and provides a quasi-sinusoidal reference to the current sense comparator. The feedback network uses a TL431+optocoupler configuration. Unlike the previously considered ones, in this case opto's transistor is connected as an emitter follower and drives the input of L6561's error amplifier. This aims at keeping low the gain of the feedback and of the overall loop at twice mains frequency so as to achieve a high power factor.

The optional 2.2  $\mu\text{F}$  capacitor connected in parallel to the upper resistor of the feedback divider acts as a soft-start circuit. The diode between the capacitor and TL431's control pin decouple the capacitor during steady-state operation so that it does not interfere with the loop gain. The other diode provides a discharge path when the converter is turned off, so that the system is always soft-started at power-up.

Figure 9 - 30W, offline, High-PF battery charger with secondary post-regulation

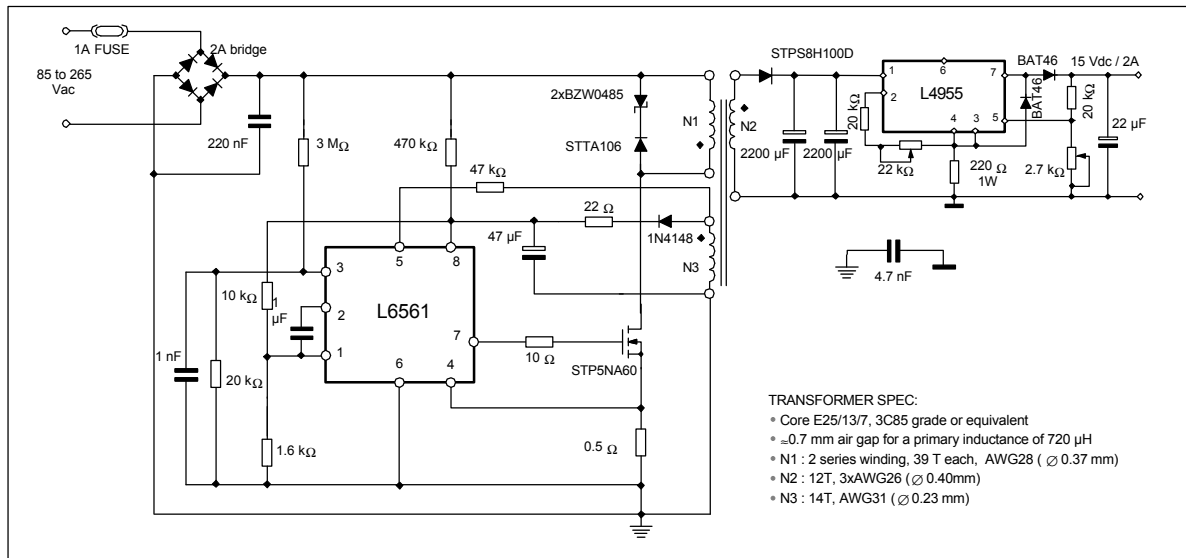
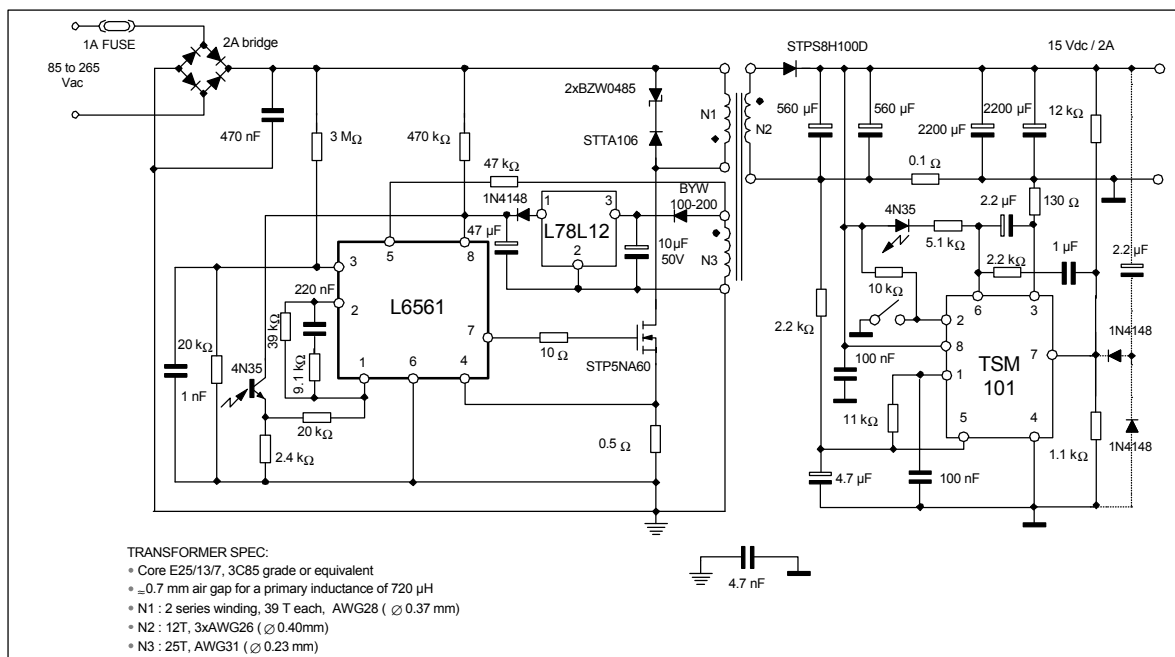

Fig. 9 presents a 30W off-line, universal mains battery charger suitable for lead-acid batteries. Compared to the previous circuit, the primary side does not change so much. The basic difference concerns the feedback that here is based on sensing the voltage developed by the auxiliary winding.

This technique ensures a high PF in such flyback configuration because of the poor coupling between secondary and auxiliary winding at low frequency. It is then quite easy to get a gain low enough at twice mains frequency. The drawback of primary sensing technique is its poor load regulation, but this is of no concern in this case.

The post regulation on the secondary side with the L4955 linear regulator (see Ref. [4] for information) ensures a high accuracy of the end-of-charge output voltage, as well as a precise constant current characteristic during battery charge. Additionally, the charge current can be adjusted from 1 to 2 A by means of the 22 k $\Omega$  trimmer. The schottky diode in series to the output prevents battery discharge when this is connected and the charger is off. The diode connected between pin 4 and pin 7 of the L4955 limits the current flowing in case of reverse battery connection.

Figure 10 - 30W, High-PF battery charger with secondary voltage/current regulation





The same battery charger can be realised without a post-regulator. Such a system is shown in fig. 10. It uses again an isolated feedback with an optocoupler and a secondary side reference/error amplifier, the TSM101, for voltage and current regulation.

This device basically incorporates a TL431 and two op-amps with or-ed outputs. One op-amp will be used for constant voltage control and the other one for constant current control. A precise internal current generator, available at pin 3, can be used to offset the intervention threshold of the constant current regulation. For more details, please refer to Ref. [5].

The voltage generated by the self-supply winding tracks the output voltage, which can be quite low (<9V) when the battery is nearly exhausted. To let the system work even under this condition the self-supply will deliver a voltage above L6561's UVLO when the output voltage falls to its minimum. As a result, however, when the charger is in voltage regulation (battery disconnected or end-of-charge) the self-supply voltage will exceed the maximum rating of the L6561. This requires the use of a linear regulator (L78L12 in the present case) to limit the excursion of the voltage. The diode in series to the output of the L78L12 prevents current diversion through the regulator at start-up.

The switch connected between TSM101's pin 2 and ground enables/disables the above mentioned internal current reference. If the switch is open, pin 2 is pulled up through the 10 k $\Omega$  resistor, the internal current generator is disabled and the constant current characteristic is set at 2A. If the switch is closed, pin 2 is grounded and the internal current reference will be enabled. Pin 3 will be offset by about 160 mV and the constant current threshold will be set at 0.3A.

### Conclusions

The three basic configurations of L6561-based flyback converters have been presented. The common characteristics, as well as the ones peculiar of each configuration have been analysed.

A number of application examples has been presented for each category. They highlight how simple and cheap but, this notwithstanding, well-performing L6561-based systems are.

It does not sound out of place, therefore, to say that the L6561 can be considered as a really interesting alternative to today's high-runner current mode controllers, especially where quite good performance and robustness are required at low cost.

### References

- [1] "L6561, Enhanced Transition Mode Power Factor Corrector", (AN966)
- [2] "L6561-based Switcher Replaces Mag Amps in Silver Boxes", (AN1007)
- [3] "Design Equations of High-Power Factor Flyback Converters Based on the L6561", (AN1059)
- [4] "L4955 Family Application Guide", (AN932)
- [5] "TSM101 Voltage and Current Controller", Datasheet