

# American National Standard

Approved: March 11, 1999  
August 5, 1999  
January 17, 2002

Secretariat: ANSLG--National Electrical Manufacturers Association

**For Lamp Ballasts**

**High Frequency Fluorescent Lamp Ballasts**

**-Supplements**

An American National Standard implies a consensus of those substantially concerned with its scope and provisions. It is intended as a guide to aid the manufacturer, the consumer, and the general public. The existence of an American National Standard does not in any respect preclude anyone, whether he has approved the standard or not, from manufacturing, marketing, purchasing, or using products, processes, or procedures not conforming to the standards. Users are cautioned to obtain the latest editions.

The American National Standards Institute does not develop standards and will in no circumstances give an interpretation of any American National Standard. Moreover, no person shall have the right or authority to issue an interpretation of an American National Standard in the name of the American National Standards Institute.

**CAUTION NOTICE:** This American National Standard may be revised or withdrawn at any time. The procedures of the American National Standards Institute require that action be taken periodically to reaffirm, revise, or withdraw this standard. Purchasers of American National Standards may receive current information on all standards by calling or writing the American National Standards Institute.

## American National Standard

Approval of an American National Standard requires verification by ANSI that the requirements for due process, consensus, and other criteria for approval have been met by the standards developer. An American National Standard implies a consensus of those substantially concerned with its scope and provisions. Consensus is established when, in the judgment of the ANSI Board of Standards Review, substantial agreement has been reached by directly and materially affected interests. Substantial agreement means much more than a simple majority, but not necessarily unanimity. Consensus requires that all views and objections be considered, and that a concerted effort be made toward their resolution. The existence of an American National Standard does not in any respect preclude anyone, whether s/he has approved the standard or not, from manufacturing, marketing, purchasing, or using products, processes, or procedures not conforming to the standards. It is intended as a guide to aid the manufacturer, the consumer, and the general public.

The American National Standards Institute does not develop standards and will in no circumstances give an interpretation of any American National Standard. Moreover, no person shall have the right or authority to issue an interpretation of an American National Standard in the name of the American National Standards Institute. Requests for interpretations should be addressed to the Committee Secretariat referred to on the title page.

**CAUTION NOTICE:** This American National Standard may be revised or withdrawn at any time. The procedures of the American National Standards Institute require that action be taken periodically to reaffirm, revise, or withdraw this standard. Purchasers of American National Standards may receive current information on all standards by calling or writing the American National Standards Institute.

*Printed and distributed by:*

Information Handling Services/Global Engineering Documents  
15 Inverness Way East, Englewood, CO 80112-5776  
Under Contract with National Electrical Manufacturers Association

Copyright ©2002 by American National Standard Lighting Group  
In Affiliation with National Electrical Manufacturers Association  
All rights reserved.

No part of this publication may be reproduced in any form,  
in an electronic retrieval system or otherwise, without  
prior written permission of the publisher.  
Printed in the United States of America

**Foreword** (This Foreword is not part of ANSI C82.11-1993.)

Suggestions for improvement of this standard should be submitted to the Secretariat C82, American National Standard Lighting Group of the National Electrical Manufacturers Association, 1300 North 17th Street, Suite 1847, Rosslyn, VA 22209.

This standard contains a collection of amendments which supersede the 1993 standard. Consisting of three supplements, noted below, which were approved by the ANSI ASC (Accredited Standards Committee) method of standard development. The 1993 standard remains unchanged except for some editorial changes and the inclusion of new supplemented information listed below:

Amendment/Change	Ballot	Report
New table of contents	N/a	N/a
ANSI C82.11a Removed table specifying starting aid distances (p 5.2.2)	m640	m641
ANSI C82.11b Program start systems (p 3.2.6) Line transient requirements (p5.10.1)	CDV/m653 LB/m636	RV/m654 R/m637
ANSI C82.11c-2000 Specifications for low voltage control interface, and marking nomenclature for controllable ballasts, (Annexes A and B)	LB/m646	R/m647

This standard was processed and approved by Accredited Standards Committee on Electric Lamps, C82, and its Sub-Committee, C82-1. Committee approval of the standard does not necessarily imply that all committee members voted for that approval. At the time it approved this standard, the C82 Committee had the following members:

**Norm Grimshaw, Chair C82, Technical Coordinator**  
**Howard Wolfman, Technical Coordinator**  
**John Marshall, Technical Coordinator**  
**Ken Denton, Consulting Editor**  
**Randolph N. Roy, Secretariat**

***Organization Represented:***

Advance Transformer Company  
 ENTERGY Services, Inc.  
 GE Lighting  
 Intertek Testing Services  
 MagneTek Lighting Products  
 OSRAM SYLVANIA  
 Philips Lighting Company

***Name of Representative:***

Norman Grimshaw  
 William "Al" Maguire  
 Rolf Bergman  
 Craig Davenport  
 Michael A. Stein  
 Peter Bleasby  
 David Mullen (Alt.)  
 Al Rousseau

ANSI C82.11 Consolidated-2002  
Supercedes ANSI C82.11-1993

At the time it approved this standard, the C82-1 Sub-Committee had the following members:

**Ken Denton, Chair, C82-1**  
**Randolph N. Roy, Secretariat**

***Organization Represented:***

***Name of Representative:***

Advance Transformer Company

Norman Grimshaw

Beth Jug

Arnold Stout

General Electric Lighting

Edward E. Hammer

MagneTek

Kenneth J. Denton

Robert Burke

William Dunham

Bill Brosius

Motorola Lighting, Inc.

Howard Wolfman

OSRAM SYLVANIA INC.

Tom Gavenonis

Philips Lighting Company

Frank M. Latassa

Thomas O. Leyh

Thomas & Betts (American Electric)

Greg Steinman

Underwriters Laboratories Inc.

John Marshall

TABLE OF CONTENTS

Foreword.....	III
1 Scope .....	1
2 Normative references .....	1
3 Definitions.....	2
3.1 Lamp types .....	2
3.1.1 Reference lamps.....	2
3.1.2 Hot-cathode lamp.....	2
3.2 Ballasting systems.....	2
3.2.1 Reference ballasts.....	2
3.2.2 Instant-start system .....	2
3.2.3 Rapid-start type systems.....	2
3.2.4 Modified rapid-start type system.....	3
3.2.5 Switch-start (preheat) systems.....	3
3.2.6 Programmed start systems.....	3
3.3 Characteristics.....	4
3.3.1 Input power factor.....	4
3.3.2 High-frequency ballast .....	4
3.3.3 High frequency current crest factor.....	4
4 Ballast marking.....	4
4.1 Marking .....	4
4.1.1 Power factor .....	4
4.1.2 High-frequency .....	4
4.2 Color coding of ballast leads .....	5
4.2.1 Supply leads.....	5
4.2.2 Lamp lead wires .....	5
4.2.3 Other ballast types.....	5
5 Ballast performance.....	5
5.1 General .....	5
5.2 Starting conditions .....	6
5.2.1 Starting.....	6
5.2.2 Fixture and circuit grounding.....	6
5.2.3 Lamp starting time vs. starting current requirement .....	6
5.3 Ballast output .....	7
5.3.1 Lamp light output.....	7
5.3.2 Lamp current .....	7
5.4 Cathode preheating current.....	7
5.5 Regulation .....	8
5.5.1 Rapid-start ballasts.....	8
5.5.2 Instant-start ballasts.....	8
5.6 Operating-current waveshape .....	8
5.6.1 Normal operating conditions .....	8
5.6.2 Special operating condition.....	8
5.7 Supplementary cathode heating .....	8
5.7.1 Switch-start ballasts.....	8
5.7.2 Rapid-start ballasts.....	9
5.8 Electro-magnetic interference suppression .....	9

Table of contents (continued)

5.9	Ballast safety.....	9
5.10	Input current, harmonic distortion.....	9
5.11	Line transient requirements.....	9
5.12	Inrush currents.....	9
6	Design center voltages .....	10
7	Application requirements .....	10
7.1	Wiring and contact resistance requirements.....	10
7.2	Operating temperature limits .....	10
7.3	Supply voltage limits.....	11
7.3.1	Average voltage for satisfactory ballast operation.....	11
7.3.2	Voltage excursions .....	11
7.4	Equipment grounding .....	11
7.5	Audible sound Level.....	11
ANNEXES .....		
ANNEX A.....		A1
1	Scope .....	A3
2	Definitions.....	A3
3	Control methods .....	A3
3.1	Control by d.c. voltage (ANSI Type 1).....	A3
3.2	Voltage specifications .....	A3
3.3	Control input current limits .....	A4
3.4	Switch-on.....	A4
3.5	Lead Wire Colors .....	A4
3.6	Control by future types of controls (ANSI Type xx).....	A4
ANNEX B.....		B1
1	Scope .....	B3
2	Purpose.....	B3
3	Technical Parameters .....	B3
3.1	Power source.....	B3
3.2	Circuit type .....	B3
3.2.1	High voltage.....	B3
3.2.2	High voltage, carrier current .....	B3
3.2.3	Low voltage.....	B3
3.2.4	Low voltage.....	B3
3.2.5	Low voltage.....	B3
3.3	Current type.....	B4
3.4	Modulation type.....	B4
3.5	Range of varying voltage.....	B4
4	Nomenclature of Designation .....	B4
5	Examples .....	B4
6	Administration of this document.....	B4
7	Revision .....	B4

Table of Contents (continued)

Tables	
Table 1 - Color coding for lamp leads.....	13
Table 2 – Ballast Factor.....	15
Table 3 – Current Harmonic Limits.....	17
Figures	
Figure 1 a.....	19
Figure 1 b.....	21
Figure A-1 .....	A5
Figure A-2 .....	A5
Figure A-3 .....	A7
Figure B-1 .....	B5

**THIS PAGE  
INTENTIONALLY  
LEFT BLANK**



# American National Standard for Lamp Ballasts- High-Frequency Fluorescent Lamp Ballasts

## 1 Scope

This standard is intended to cover high frequency ballasts which have rated open-circuit voltages of 2000 volts or less and are intended to operate at a supply frequency of 50 Hz or 60 Hz. This comprises ballasts for hot-cathode fluorescent lamps, either switch-start (preheat-start), rapid-start (continuously heated cathodes), modified rapid start, *programmed start*, or instant start used primarily for lighting purposes. The ballast and lamp combinations covered by this specification are normally intended for use in room ambient temperatures of 10°C to 41°C. At ambient temperatures outside this range, certain special operating characteristics may be required.

## 2 Normative references

The following standards contain provisions, which through reference in this text constitute provisions of this American National Standard. At the time of publication, the editions indicated were valid. All standards are subject to revision, and parties to agreements based on this American National Standard are encouraged to investigate the possibility of applying the most recent edition of the standards indicated below.

ANSI/NFPA No. 70-1993, *National Electrical Code*

ANSI /IEEE C62.41-1980 (R1995), *Guide for Surge Voltages in Low-Voltage AC Power Circuits*

ANSI C78.1-1991 (R1996), C78.2-1991(R1996), C78.3-1991(R1996), C78.4-1992(R1997), *American National Standards for Dimensional and Electrical Characteristics of Fluorescent Lamps*

ANSI C82.2-1984 (R1992), *American National Standard Methods of Measurement of Fluorescent Lamp Ballasts*

ANSI C82.3-1983 (R1998), *American National Standard Specification for Fluorescent Lamp Reference Ballasts*

CAN/CSA C22.2 No.0.16 M92, *Measurements of Harmonic Currents, General Requirements, A National Standard of Canada*

IES LM40-1988, *Life Performance Testing of Fluorescent Lamps*

US Code of Federal Regulations #47, Chapter 18. (*Federal Communications Commission Requirements for RFI*)

Public Law 100-357, *National Appliance Energy Conservation Amendments of 1988*.

ANSI/UL 935-1992, *Underwriters Laboratories Inc., Standard for Fluorescent Lamp Ballasts*

### **3 Definitions**

#### **3.1 Lamp types**

##### **3.1.1 Reference lamps.**

Seasoned lamps which, under stable operating conditions and in conjunction with the specified reference ballast, operate at values of lamp voltage, lamp wattage (for rapid-start lamps arc wattage is to be used and not total wattage), and lamp current, each within 2 1/2% of the values given in the appropriate lamp standard (see American National Standard Dimensional and Electrical Characteristics of Fluorescent Lamps, ANSI C78.1, C78.2, C78.3). Reference lamps of the rapid-start type are operated in circuits in which their cathodes are continuously heated by appropriate low-voltage power sources.

##### **3.1.2 Hot-cathode lamp**

An electric discharge lamp in which the electrodes operate at incandescent temperatures and the cathode fall voltage is relatively low (less than 20 volts). The current density at the cathodes is relatively high, and lamps may be designed to carry any desired current up to several amperes. The energy to maintain the cathodes at a sufficient thermal emission may come either from the arc (arc heating), from circuit elements (voltage heating), or from both.

#### **3.2 Ballasting systems**

##### **3.2.1 Reference ballasts**

Series impedance-type ballasts, which are designed, manufactured, and maintained for the purpose of providing comparison standards for use in testing ballasts or lamps. They are also used in selecting the reference lamps that are needed in the work of testing ballasts. Reference ballasts are characterized by constant impedance over a wide range of operating current and also by constant characteristics that are relatively uninfluenced by time, temperature, magnetic surroundings, etc. The general specifications for reference ballasts are in ANSI C82.3. The values of reference current, impedance, line voltage and cathode conditioning for the reference ballasts to be used with each size and rating of lamp are given in the normative referenced ANSI C78 Standards, American National Standards for Dimensional and Electrical Characteristics of Fluorescent Lamps, as specified in paragraph 2 above.

##### **3.2.2 Instant-start system**

Those systems in which an electric discharge lamp is started by the application to the lamps of a voltage sufficiently high to eject electrons from the electrodes by field emission, initiate electron flow through the lamp, ionize the gases, and start a discharge through the lamp without previous heating of the electrodes.

##### **3.2.3 Rapid-start type systems**

Those systems in which hot-cathode electric discharge lamps are operated under the following conditions: (1) the lamps are started with the cathodes heated to a temperature sufficient for adequate electron emission and without establishing local ionization across the cathodes; (2) such heating is accomplished either by means of low-voltage heater windings in the ballast itself or by separate low-

voltage transformers or by other means of heating the cathodes; (3) sufficient voltage is applied across the lamp and between the lamp and the starting aid (usually the fixture itself) to initiate the discharge when the cathodes reach a temperature high enough for adequate emission; and (4) cathode heating voltage is maintained even after the lamp is in full operation.

**NOTE:** Two types of rapid-start systems have evolved: (1) those for lamps with nominal 3.6 volt cathodes (low resistance) and (2) those for lamps with nominal 8.0 volt cathodes (high resistance). In some cases the same lamp can be suitable for operation in either rapid-start or switch start (preheat-start) system. Other starting scenarios to follow.

### **3.2.4 Modified rapid-start type system**

Those systems in which hot-cathode electric discharge lamps are operated under the following conditions: (1) the lamps are started with the cathodes heated to a temperature sufficient for adequate electron emission and without establishing local ionization across the cathodes; (2) such heating is accomplished either by means of low-voltage heater windings in the ballasts itself, by separate low-voltage transformers, or by other means of heating the cathodes; (3) sufficient voltage is applied across the lamp and between the lamp and the starting aid (usually the fixture itself) to initiate the discharge when the cathodes reach a temperature high enough for adequate emission; and (4) cathode heating is reduced or removed after the lamp is in full operation.

### **3.2.5 Switch-start (preheat) systems**

Systems in which hot-cathode electric discharge lamps are started with the cathodes preheated through the use of a starting switch, either manual or automatic in its operation. The starting switch, when closed, connects the two cathodes, in series, in the ballast circuit so that current flows to heat the cathodes to emission temperature. When the switch is opened, a voltage surge is produced which initiates the discharge. Only the arc current flows through the cathodes after the lamp is in operation.

### **3.2.6 Programmed start systems**

Those systems in which the sequence for starting hot-cathode electric discharge lamps is as follows: (1) the lamp cathodes are initially preheated to a temperature sufficient for adequate electron emission and without establishing local ionization across the cathodes; (2) this cathode heating is accomplished by supplying the required energy from a voltage or current source in the ballast itself, while during the preheating period the voltage across the lamp is kept below a level to initiate a glow discharge; (3) after the preheating period the voltage across the lamp is increased to a sufficient level to initiate the arc breakdown discharge; and (4) cathode heating may be reduced or removed after the lamp is in full conduction.

### 3.3 Characteristics

#### 3.3.1 Input power factor

Power Factor is dependent upon the current's wave shape as well as the phase relationship between the current and voltage. The power factor is to be calculated by determining the ratio of the active power to the apparent power. The active power is to be measured with a wattmeter capable of indicating the true rms power in watts. The apparent power is to be the product of the true rms values of the input voltage and current.

$$\text{Power Factor} = \frac{\text{Active Power (watts)}}{\text{Apparent Power (volt amperes)}}$$

#### 3.3.2 High-frequency ballast

A device, which operates at a supply frequency of 50 or 60 Hz: and operates the lamp at frequencies between 10 kHz and 500 kHz.

#### 3.3.3 High frequency current crest factor

The high frequency current crest factor is equal to the peak current of the modulated or unmodulated envelope divided by the effective rms current.

## 4 Ballast marking

### 4.1 Marking

Ballasts shall be marked to indicate the input supply voltage, frequency, and current, the manufacturer or supplier; ballast type designation; and the number, type and wattage or current of fluorescent lamps the ballast is to operate.

#### 4.1.1 Power factor

Only ballasts operating with an average power factor of 90% or above shall be labeled as high-power factor type. Ballasts of the uncorrected type and operating at a power factor of less than 90% need not be marked with a power factor.

#### 4.1.2 High-frequency

High frequency ballasts may be marked H.F. or electronic.

## 4.2 Color coding of ballast leads

### 4.2.1 Supply leads

The following color codings are for the supply lead wires of ballasts:

- On ballasts with two supply lead wires, when one lead wire connects to a neutral wire, that lead wire shall be white or neutral gray and the other shall be black.
- On ballasts with two supply lead wires that connect to ungrounded lines, both leads shall be black.

### 4.2.2 Lamp lead wires

The following color codings are for the lamp leads of electronic ballasts:

On a single-lamp ballast of the continuously heated cathode type (rapid start), the leads to that lamp cathode operated at the highest voltage with reference to either of the supply leads shall be RED. The lead wires connected to the other cathode shall be BLUE.

On a multi-lamp ballast of the series connected continuously heated cathode type (rapid start), or series connected instant start type, the leads to that lamp cathode operated at the maximum voltage with reference to either of the supply leads shall be RED. The leads connected to the cathode at the other extreme of voltage relative to the RED cathode shall be BLUE. For two-lamp rapid start ballasts, the leads to the pair of common cathodes shall be either YELLOW-BLUE TRACER OR YELLOW.

When more than two lamps are operated in a rapid start mode, the leads to each cathode or pair of cathodes, beginning at the highest voltage (RED) end shall have colors used in the order shown in Table 1. If a circuit-interrupting feature is required for instant start ballasts, the lamps leads for the circuit-interrupting leads shall be YELLOW.

On a (1), (2) or (3) lamp instant start ballast where the lamps are operated independently and have a common connection, the common lamp lead shall be RED, and the independent lamps lead wires shall be BLUE. On a (4) lamp instant start ballast where the lamps are operated independently and have a common connection, the common lead wires shall be YELLOW or YELLOW/WHITE and the independent lamp leads shall consist of two BLUE and two RED leads.

If a circuit-interrupting feature is required, the lamp lead wires for the circuit-interrupting lead wires shall be YELLOW and the independent lamp lead wires shall be BLUE.

### 4.2.3 Other ballast types

Ballasts not covered by 4.2.1 and 4.2.2 shall comply with these requirements insofar as possible.

## 5 Ballast performance

### 5.1 General

Measurements necessary to determine ballast performance shall be made in accordance with ANSI C82.2 as applicable.

## 5.2 Starting conditions

### 5.2.1 Starting

For satisfactory lamp starting a ballast, when operated at any supply voltage between 90% and 110% of its rated supply voltage and frequency, shall follow the requirements of this standard or as specified otherwise in the normative referenced ANSI C78 lamp standards. High frequency lamp data is under consideration.

When ballasts are designed to operate lamps in parallel circuits, the relevant requirements shall be met for each separate lamp, both with and without lamps operating or preheating in other circuits.

### 5.2.2 Fixture and circuit grounding

Rapid-start lamps, and switch-start (preheat-start) lamps when operated in circuits of the rapid-start type, require a starting aid consisting of a metal strip (usually an integral part of the fixture), the surface of which shall be at least equal to the lamp diameter.

This surface shall extend essentially the full length of the lamp and shall be connected to ground. The distance from the starting aid to the bulb wall, as measured in a direction normal to the surface of the starting aid, shall not be greater than specified in the normative referenced ANSI C78 Standards designated in clause 2.

Lamp shall not contact the ground plane. Minimum distance to be 0.12 inch (3 mm). For remote mounted lamps and dimming applications, greater spacing may be needed.

Rapid start ballast circuits and connections (including ground connections) shall be such that the potential difference between the starting aid and one of the cathodes of each lamp will be greater than the minimum specified in ANSI C78.1 and C78.2.

Use on ungrounded supplies is not recommended.

### 5.2.3 Lamp starting time vs. starting current requirement

High frequency ballasts shall meet the requirements of starting time and starting current as listed and as graphically defined in figure 1a and 1b.

On testing starting time on high frequency rapid start ballasts, tests shall be made in ambient temperatures of 77°F +/- 5°F with proper starting aid spacing and grounding conditions. The test shall be repeated on six sets of seasoned lamps (minimum 100-hour lamps), using the average as the results. If erratic results begin to occur lamps should be changed.

At rated line voltage the preheat time ( $t_1$  to  $t_2$ ) shall be 500 milliseconds minimum, or be equal to or greater than 90% of the results of a corresponding supply frequency commercially available from two lamp magnetic ballasts that meets the requirements of C82.1 and C78.1 using the same lamps. Other starting scenarios which effectively produce the same electrode temperatures prior to starting as those just defined are under consideration.

At 90% rated line voltage the transition time ( $t_2$  to  $t_3$ ) shall be 100 milliseconds or less, or equal to or less than the results of a corresponding supply frequency commercially available magnetic ballasts that meets the requirements of C82.1 and C78.1 using the same lamps.

On a high frequency rapid start system, the maximum ionization (starting) lamp current is defined as the average value of the RMS glow current from the onset of the glow current to  $t_2$  and shall not exceed 25 ma.

On testing starting time on high frequency instant start ballasts, tests shall be made in ambient temperatures of  $77^{\circ} \pm 5^{\circ}\text{F}$ , be made at 90% of the rated supply voltage, and be repeated on six sets of lamps, using the average as the results.

The maximum start time ( $t_1$  to  $t_3$ ) shall be 100 milliseconds or less, or less than the corresponding supply frequency commercially available magnetic ballast that meets the requirements of ANSI C82.1 and C78.3 using the same lamps.

If the corresponding commercially available magnetic ballast that meets the requirements of ANSI C82.1 and C78.3 does not exist the starting time ( $t_1$  to  $t_3$ ) shall be 100 ms or less.

Each lamp of a multi-lamp ballast must be tested to assure the requirements of this paragraph are met. Multi-lamp ballasts shall be tested for combinations of rated lamp footage and quantities.

### 5.3 Ballast output

An electronic ballast shall provide the operating characteristics given in 5.3.1 and 5.3.2 when connected to any specified complement of reference lamps.

#### 5.3.1 Lamp light output

With rated voltage applied to the input of the ballast, the minimum light output shall be the product of the ballast factor as listed in Table 2 and the light output of the same reference lamp when operated on its reference ballast of its rated voltage, and divided by 100. The maximum light output shall be limited by the maximum permissible lamp current as specified in 5.3.2.

#### 5.3.2 Lamp current

With rated voltage applied to the input of the ballast, the lamp current in a reference lamp shall not exceed 107.5% of the current delivered to the same lamp by a reference ballast at its rated input voltage.

When ballasts are designed to operate more than one lamp, each circuit shall meet this requirement, both with and without lamps operating or preheating in the other circuits.

### 5.4 Cathode preheating current

Ballasts designed for the operation of switch start lamps shall provide preheating current within the limits required by the ANSI C78.1, C78.2, and C78.4 as appropriate.

## 5.5 Regulation

### 5.5.1 Rapid-start ballasts

Rapid start ballasts shall, at 90% and 110% of rated supply voltage, operate a reference lamp at a level of light output not less than 75% or greater than 125%, respectively, of the light output of the same lamp when it is operated with the same ballast at rated input voltage.

### 5.5.2 Instant-start ballasts

Instant start ballasts shall, at 90% and 110% of rated supply voltage, operate a reference lamp at a level of light output not less than 85% or greater than 115% respectively, of the light output of the same lamp when it is operated with the same ballast at rated input voltage.

## 5.6 Operating-current waveshape

### 5.6.1 Normal operating conditions

With rated voltage applied to the input of the ballast, the current waveshape supplied to a warmed-up reference lamp shall have a high frequency crest factor that does not exceed 1.70<sup>1</sup> unless otherwise specified on the lamp data sheet.

Successive half cycles of lamp current shall show substantially the same shape.

### 5.6.2 Special operating condition

If multi-lamp ballasts are so designed that the failure of one lamp permits the other lamps to continue in operation, the current waveshape under these conditions shall meet the same requirements as given in 5.6.1 for normal operation.

## 5.7 Supplementary cathode heating

### 5.7.1 Switch-start ballasts

Switch-start ballasts shall not furnish a current greater than 110% of the 60 Hz arc stream current to any cathode terminal of a lamp in normal operation.

---

<sup>1</sup> SECRETARIAT NOTE: The table was editorially converted to text.



### 5.7.2 Rapid-start ballasts

Rapid-start ballasts shall provide supplementary cathode heating as follows:

1. When two cathodes are supplied from a common winding, they shall be connected in parallel.
2. The cathode heating voltage shall be measured using non-inductive load resistors. All cathode windings must be loaded during this measurement. With the rated voltage applied to the input of the ballast, the cathode heating windings shall deliver voltages to the dummy resistors within the limits shown on the appropriate lamp data sheet.
3. When reference lamps are in normal operation at rated input voltage, the voltage across any cathode shall be within the limits shown on the appropriate lamp data sheet.

### 5.8 Electro-magnetic interference suppression

Fluorescent lamp systems may be a source of electromagnetic radiation at radio frequencies. High-frequency ballasts shall comply with FCC regulations, Title 47 of the US Code of Federal Regulations, Part 18.

### 5.9 Ballast safety

Ballast shall comply with ANSI/UL 935.

### 5.10 Input current, harmonic distortion

This is a safety requirement for protection of the neutral wire in 3-phase, 4-wire "Y"-connected systems where the neutral wire is the same size as the phase wire. It is also to minimize voltage distortion on the power lines.

A non-sinusoidal (distorted) input current waveform is the root-sum-square of the fundamental and harmonic components. The 3rd harmonic and odd multiples of the 3rd harmonic (9th, 15th, 21st, etc.) add in the neutral conductor on a 3-phase, 4-wire "Y"-connected system. The fundamental and other harmonics will cancel in the neutral conductor with a balanced system load.

The harmonic distribution of the input current shall meet each of the limits as specified in Table 3.

### 5.11 Line transient requirements

Electronic high-frequency ballasts are more susceptible to line transients than line frequency magnetic ballasts. Therefore, transient protection shall be included. The requirement for this transient protection is in ANSI/IEEE C62.41, Class A operation. The line transient test shall consist of seven strikes of a 100KHz Ring Wave, 2.5 KV<sup>2</sup> level, for both common mode and differential mode

### 5.12 Inrush currents

There is a need to control inrush current transients caused by capacitor charging. The limits are to be determined.

---

<sup>2</sup> Higher values may be used as appropriate

## 6 Design center voltages

The following voltages are the design center input voltages for fluorescent lamp ballast:

120	240
127	277
208	347
220	480

See ANSI/NFPA 70, National Electrical Code, for maximum voltage-to-ground limitations and grounding requirements.

## 7 Application requirements

### 7.1 Wiring and contact resistance requirements

Even relatively small amounts of resistance in series with the cathode of a rapid start lamp may seriously interfere with lamp starting and operation because of lowered heater circuit voltage. The added resistance in any cathode circuit shall not exceed at any time the following values.

<u>Lamp Type (mA)</u>	<u>Maximum Added Resistance Any Cathode Circuit (Ohms)</u>
500 or less	0.5
800 (high output)	0.2
1500	0.2

In addition, good installation practice requires that lead lengths from the ballast to the lamps be kept to the minimum length necessary. Excess wires should not be coiled or bundled in order to keep inductances to a minimum. Unless otherwise specifically allowed by the manufacturer, leads from the ballast to the lamp should not exceed 6 feet in length in order to minimize resistive and high frequency line losses thus assuring more power to the lamps. Note: at higher lamp drive frequencies the distributed inductive reactance  $X_L$  and capacitive reactance  $X_C$  components have a greater effect on the proper starting and operation of the lamp particularly as lead lengths increase. The manufacturer should be consulted for proper wiring practice appropriate for the intended installation.

### 7.2 Operating temperature limits

The service installation must be designed so that the temperature at the hottest spot on the ballast case shall not exceed 90°C under actual operating conditions. High-frequency ballasts shall also not exceed manufacturer's recommendations if less than 90°C is specified.

### 7.3 Supply voltage limits

#### 7.3.1 Average voltage for satisfactory ballast operation

The average voltage of the supply system should not vary more than minus 7.5% or more than plus 5% from the input voltage rating shown on the ballast label.

#### 7.3.2 Voltage excursions

For satisfactory ballast operation, the supply voltage excursions must not exceed  $\pm 10\%$  of the ballast input rating.

### 7.4 Equipment grounding

Exposed non-current-carrying metal parts of fluorescent lamp ballasts (such as the ballast case) shall be grounded.

### 7.5 Audible sound Level

Noise is an inherent characteristic of all ballasts and cannot be completely eliminated.

Care should be exercised in the selection of the ballast location and the method of mounting because ballast noise can be amplified by reflections from surrounding objects and by resonance of the mechanical mounting and electrical connections. This unintentional amplification can make the ballast appear to produce considerable more noise than that generated by the ballast. The ballast or luminaire manufacturer, or both, should be consulted for specific recommendations for a quiet installation.

**THIS PAGE  
INTENTIONALLY  
LEFT BLANK**

Table 1 - Color coding for lamp leads

<b>Series connected operation</b>		
<b>Lamp quantity</b>	<b>Circuit</b>	<b>Color coding for electronic ballast lamp leads</b>
1	Rapid start	Red-blue
2	Rapid start	Red-yellow-blue
3	Rapid start	Red-yellow-blue/white-blue
4	Rapid start	Red-yellow-blue/white-brown-blue
1	Instant start with circuit interrupting requirement	Red-yellow-yellow
2	Instant start with circuit interrupting requirement	Red-yellow-yellow-blue
<b>Independent (parallel) lamp operation</b>		
<b>Lamp quantity</b>	<b>Circuit</b>	<b>Color coding for electronic ballast lamp leads</b>
1	Instant start	Blue-red
2	Instant start	Blue-blue-red
3	Instant start	Blue-blue-blue-red
4	Instant start	Blue-red-blue-red-yellow-yellow
2	Instant start with circuit interrupting requirement	Blue-blue-yellow-yellow
<b>Caution:</b> Wire color and/or connections may differ in some instant start applications between 60HZ and high frequency ballasts		

**THIS PAGE  
INTENTIONALLY  
LEFT BLANK**

**Table 2 – Ballast Factor**

Lamp Type	Minimum ballast factor (percent)
32W/48T8/RS	85
40W/48T12/RS	85
34W/48T12/RS*	85
75W/96T12/IS	85
60W/96T12/IS	85
110W/96T12/HO	85
40W/22T5/RS/2G11	85
*Additional starting requirements for 34 watt lamps with high frequency ballasts are under investigation	
NOTE – Ballast factor is the ratio of light output of the subject ballast on a reference lamp to the light output of a 60 hertz reference ballast on the same reference lamp measured in accordance with ANS C82.2.	

**THIS PAGE  
INTENTIONALLY  
LEFT BLANK**

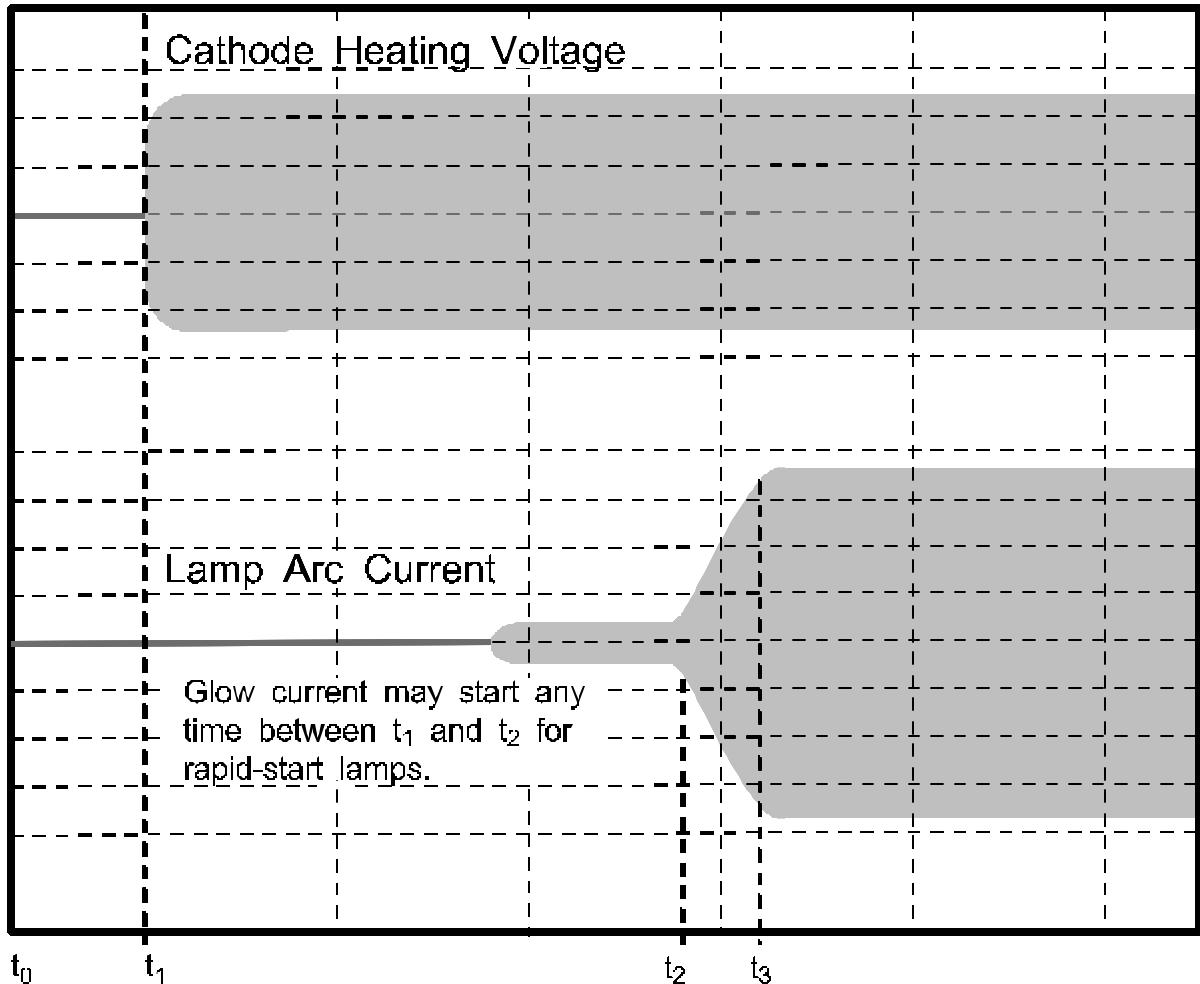

**Table 3 – Current Harmonic Limits**  
**Maximum Values\***

Fundamental (by definition)	100%
2 <sup>nd</sup> Harmonic	5%
3 <sup>rd</sup> Harmonic	30%
Individual Harmonics >11 <sup>th</sup>	7%
Odd Triples**	30%
Harmonic Factor(Distortion Factor)	32%
* Measured under rated line voltage	
** The root-sum-square of the 3 <sup>rd</sup> , 9 <sup>th</sup> , 15 <sup>th</sup> , 21 <sup>st</sup> , etc. harmonics	
<p>NOTES</p> <p>1 Band width is limited to 2Khz</p> <p>2 All values are percentages of the fundamental</p> <p>3 Lower limits are under consideration</p>	
<p><b>Caution:</b></p> <p>1) The National Electrical Code and the Canadian Electrical Code do not allow reduction of neutral capacity for that portion of the load which consists of electric-discharge lighting. However, more stringent limits may be required for distribution systems where the neutral wire is smaller than the phase wire.</p> <p>2) The harmonics and other aspects of the harmonic factor can also play a role in system interactions (i.e.: components, unbalanced loads, type of distribution system, etc.)</p>	

**THIS PAGE  
INTENTIONALLY  
LEFT BLANK**

Figure 1 a



### Rapid Start Time (t) Definitions

- $t_0$  Application of power
- $t_1$  Appearance of cathode heating voltage
- $t_2$  When rms value of glow current reaches 10% of the rms lamp current at  $t_3$
- $t_3$  Peak of the first half cycle that is at least 90% of the waveform and is sustained at that value

**THIS PAGE  
INTENTIONALLY  
LEFT BLANK**

Figure 1 b

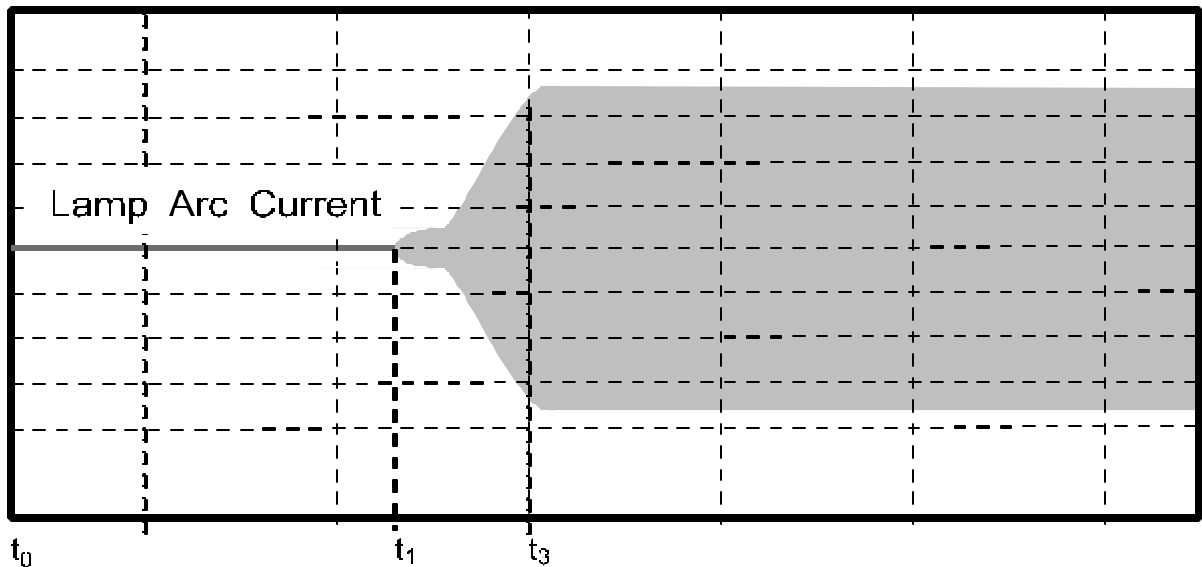

### Instant Start Time (t) Definitions

- $t_0$  Application of power
- $t_1$  First appearance of glow current
- $t_3$  Peak of the first half cycle that is at least 90% of the waveform and is sustained at that value

**THIS PAGE  
INTENTIONALLY  
LEFT BLANK**

## **ANNEXES**

**THIS PAGE  
INTENTIONALLY  
LEFT BLANK**



Normative

ANNEX A

Specification for

Low Voltage Control Interface for Controllable Ballasts

**THIS PAGE  
INTENTIONALLY  
LEFT BLANK**

## 1 Scope

This annex specifies the control interface for controllable ballasts. The lamp power (light output) of the ballast is controlled between minimum/off and maximum values by the control signal applied to the control terminals or lead wires of the ballast. This Annex provides the general and performance criteria for different control interfaces used to control the light output of electronic fluorescent lighting ballasts.

If the control signal is not connected, the ballast shall give the maximum valued of lamp power as defined in the main body of this standard.

This annex does not cover any requirements for the control unit.

## 2 Definitions

Controllable ballasts — Ballasts capable of controlling the lamp power (light output) between the minimum value (or OFF) and the maximum value by the signal on the control terminals of the ballast.

Control terminals — Connections to the controllable electronic ballast which are used to apply a control signal for changing the light output. The power supply terminals can also act as control terminals.

Control signal — Signal, which may be an a.c. or d.c. voltage or current, and which by analog, digital or other means may be modulated to convey the necessary information to the ballast for the purpose of controlling the light output.

Maximum value of lamp power (of a controllable ballast) — Lamp power (light output) which complies with ANSI C82.11, section 5, unless otherwise declared by the manufacturer or responsible vendor.

Minimum value of lamp power (of a controllable ballast) — Lowest percentage of the lamp power (light output) as defined ANSI C82.11, section 5, or otherwise declared by the manufacturer or the responsible vendor.

## 3 Control methods

### 3.1 Control by d.c. voltage (ANSI Type 1)

### 3.2 Voltage specifications

In Figure A-1, the lamp power (light output) of a controllable ballast is controlled by the d.c. voltage on the control input of the controllable ballast. The d.c. voltage has the following characteristics:

Control signal range

$V_{1,2} = 10 \text{ V}$	maximum value of lamp power
$V_{1,2} = 1 \text{ V}$	minimum value of lamp power
$1 \text{ V} \leq V_{1,2} \leq 10 \text{ V}$	lamp power rising from min. to max. value
$0 \text{ V} < V_{1,2} < 11 \text{ V}$	stable lamp operation
$0 \text{ V} < V_{1,2} < 1 \text{ V}$	minimum light output

Depending on current-carrying capacity, several controllable ballasts can be connected to one control unit in the way as shown in Figure A-2

The controllable ballast is current sourcing. (See Figure A-3)

The ballast shall not be damaged when the control ballast voltage  $-15 < V_{1,2} < +15$  volts.

The ballast shall not be damaged when the control input voltage  $V_{1,2}$  is between  $-15$  V and  $+15$  V.

The ballast shall not produce voltages that exceed the limiting values for the control unit and under no circumstances shall exceed the following:  $-15$  V  $< V_{1,2} < +15$  V.

The control terminals shall be reverse polarity protected. In that case the ballast shall operate with minimum light output or shall not operate.

At control voltages between 0V and 11V there shall be stable light output. This shall be tested by visual inspection.

### 3.3 Control input current limits

Limits for the control input current, to be supplied to the control unit, are 10  $\mu$ A minimum and 2mA maximum. (See Figure A-3)

The value of the control input current shall be declared by the manufacturer of the ballast.

### 3.4 Switch-on

Switch-on is allowed at any dimming position.

### 3.5 Lead Wire Colors

The lead wire color shall be violet for the "+V" designation. The lead wire color shall be gray for the "-V" designation.

### 3.6 Control by future types of controls (ANSI Type xx)

(Reserved for future technology and control methods).

Figure A-1

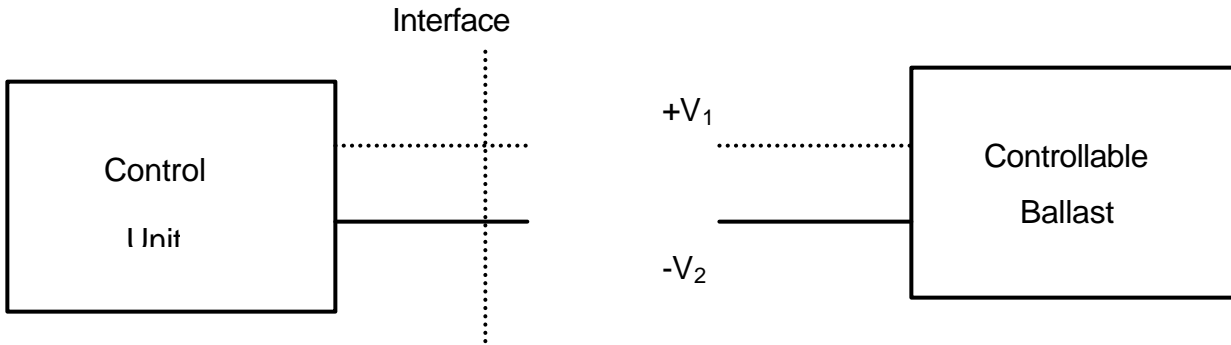
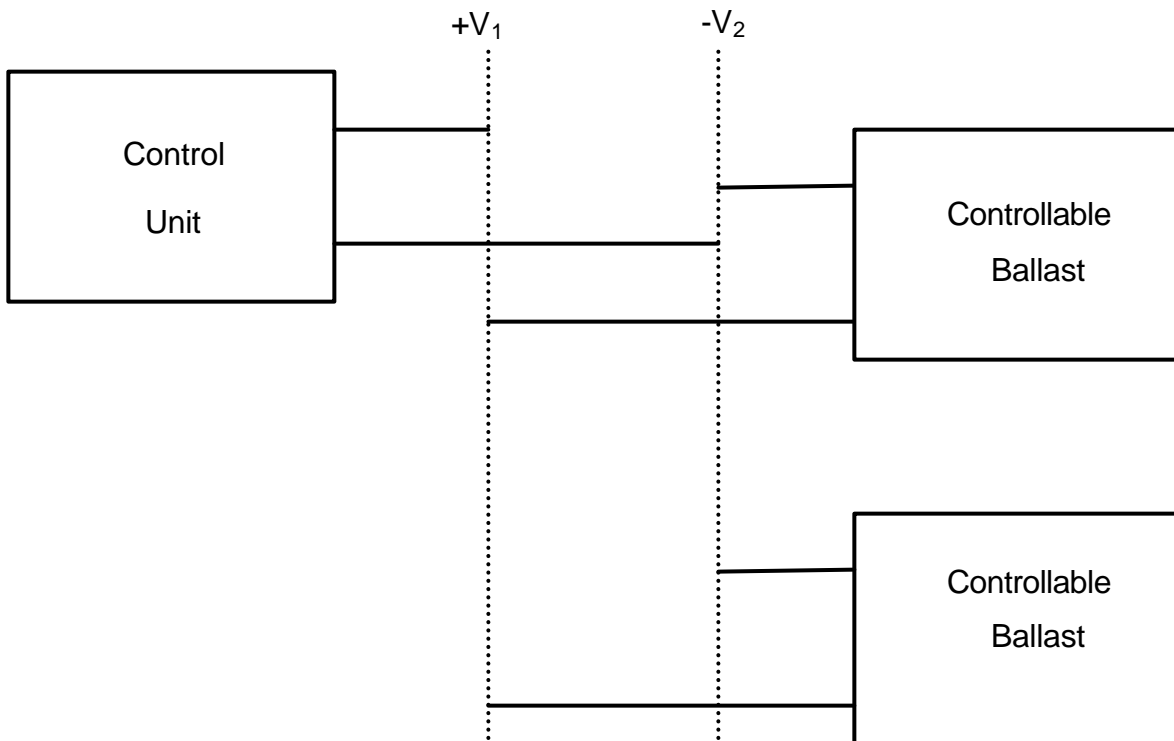
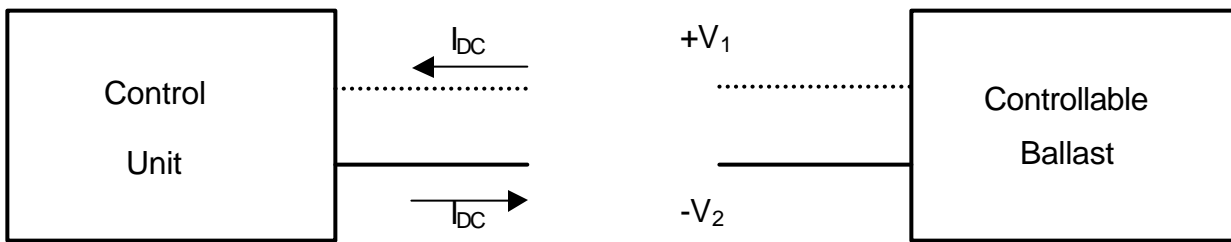

Figure A-2



**THIS PAGE  
INTENTIONALLY  
LEFT BLANK**

Figure A-3



**THIS PAGE  
INTENTIONALLY  
LEFT BLANK**



Informative

ANNEX B

Specification for

Marking Nomenclature for Controllable Ballasts

**THIS PAGE  
INTENTIONALLY  
LEFT BLANK**

## 1 Scope

This annex describes a recommended system of designation and method of nomenclature for identifying circuits used for dimming control of fluorescent lighting ballasts.

## 2 Purpose

The purpose of the system of designation is to identify, by a code, the interchangeability of fluorescent ballasts within a given dimming control system. The code is intended to be marked on the ballast and in its documentation. The code would be used by specifier's and installer's for the selection and installation of fluorescent ballasts.

The recommended system of designation is established in a manner that is intended to allow for revision as the technology and manner of dimming control evolves.

The electrical parameters described in this Annex are mainly to ensure expected performance. New or incompatible technology shall comply with all applicable safety standards.

## 3 Technical Parameters

### 3.1 Power source

The ballast can either be a source (come from the ballast) or a sink (come from an external supply) for the controlling voltage or current.

### 3.2 Circuit type

The dimming control circuit voltage or current can be one of the types described in 3.2.1 - 3.2.5.

#### 3.2.1 High voltage

Between primary (supply) lead wires or terminals, or between a primary (supply) lead wire or terminal and a tertiary primary lead wire or terminal.

#### 3.2.2 High voltage, carrier current

Between primary (supply) lead wires or terminals and where the dimming signal is a high frequency by one of the modulation types (below) and superimposed onto the primary supply circuit.

#### 3.2.3 Low voltage

Between two lead wires or terminals. If the control circuit is low voltage, the varying voltage shall be in the range from 0 volts to 50 volts (rms if ac or peak if dc). If the voltage is greater than 50 volts, the control circuit shall be considered to be a high voltage circuit.

#### 3.2.4 Low voltage

Between two lead wires or terminals AND designated as a power limited, Class 1, 2, or 3 circuit according to ANSI/NFPA 70 (The National Electrical Code™) and ANSI/UL 935.

#### 3.2.5 Low voltage

Between two lead wires or terminals and designated as "ANSI Type 1" or "ANSI 1". Such a designation shall comply with Annex A of this standard, ANSI C82.11. Such a designation may additionally be designated as a limited energy type as described in 3.2.4.

### 3.3 Current type

If the control circuit is low voltage, the current can be either a varying AC or DC.

### 3.4 Modulation type

The control circuit method of modulation can be either amplitude (analog), pulse width (analog), phase cut (analog), or digital. The digital form complies with the industries practices.

### 3.5 Range of varying voltage

The range of the varying voltage is the normal range expected for the intended dimming operation.

## 4 Nomenclature of Designation

The nomenclature consists of the fields identified above according to the following coding shown in Figure B1.

## 5 Examples

Code is ILDA 0-10v - this means the dimming control voltage is supplied by the ballast, it is low voltage, is direct current, the varying amplitude (typically by a potentiometer) adjusts the dimming, and the range is 0 volts for dim and 10 volts for full brightness.

Code is E2AP - this means the dimming control voltage comes from an external source (typically by a master controller or an energy management system), the external source circuit is designated as Class 2 (the ballast is capable of being connected to a Class 2 circuit and will not cause a hazardous condition on the dimming circuitry), is alternating current, and the dimming is by a pulse width modulation scheme.

## 6 Administration of this document

## 7 Revision

Requests for additional parameter fields because of technical innovations can be addressed to ANSI Subcommittee Administrator for C82-1.

Figure B-1

Designation	V	W	X	Y	Z
# - Source(Internal) : Sink (External)					
ANSI Type 1 (ANSI1): Line (Primary):Low Voltage (Low) Line (Primary Carrier Current)					
# - AC(A) : DC (D)					
# - Amplitude (A) : Pulse Width (W): Phase Cut (P): Digital (D)					
# - Range of varing voltage (dim to bright)					
<p><b>NOTE:</b> # - Add if other than ANSI1</p>					