

# Design Idea DI-42

## **TinySwitch**<sup>®</sup> Non-isolated Flyback (Buck/Boost) Converter



Application	Device	Power Output	Input Voltage	Output Voltage	Topology
Appliances	TNY254P	1.2 W	85-265 VAC	12 V	Buck/Boost

### Design Highlights

- Lowest cost non-isolated flyback converter
- Inherently short circuit & thermal overload protected
- Excellent line and load regulation characteristics
- Operates at 85 °C, without forced cooling
- Meets EN61000-4-5 (2 kV line surge – simple modification provides a 6 kV line surge withstand)
- Input AC line is fed directly to the output
- Available for prototyping in DAK-7

### Circuit Features

This non-isolated Flyback (Buck-Boost) converter has been implemented using a *TinySwitch* TNY254P, which minimizes cost, PCB space and design time.

The most typical application for the circuit of Figure 1 is powering a TRIAC drive and associated circuitry, in a consumer or industrial appliance, having TRIAC controlled motors.

The combined voltage drops of Zener diode (VR1) and optocoupler diode (U2) set the output voltage. Due to the digital nature of the *TinySwitch* output voltage regulation scheme, the current transfer ratio (CTR) of the optocoupler is not critical and

there is no analog control loop to compensate. The low switching frequency under light and no-load conditions provides very low power consumption under these conditions – see Figures 2 and 3.

Providing power for driving TRIACs normally requires the output of the supply to be referenced to the input line as shown in Figure 1. Therefore, only half-wave rectification is used and the switch must be in the return or neutral side of the primary switching circuit. In these applications, EMI filtering is normally done at the system level and is therefore not shown here.

The circuitry shown allows this converter to meet 2 kV surge requirements according to IEC standards. To extend surge withstand to 6 kV, an MOV must be added between the Line input and the node where D3 connects to R2. Additionally, D3 must be replaced with 100 Ω, 5 W surge-rated resistor (See DAK-7 for details).

The high efficiency of this converter (see Figure 4) allows the circuit to operate to very high ambient temperatures of up to 85 °C, as sometimes specified in household appliances and industrial applications.

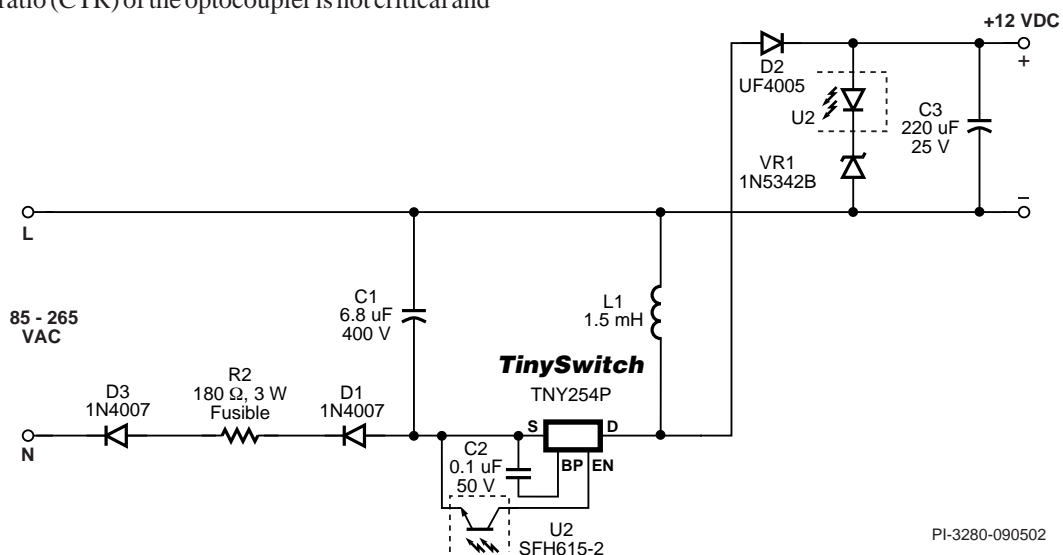

PI-3280-090502

Figure 1. *TinySwitch* – TNY254P, 1.2 W, 12 V 100 mA.

## Key Design Points

- Use low cost optocoupler - CTR is unimportant for output regulation.
- PCB traces that carry switching currents should be short and wide to minimize EMI.
- Select input and output capacitors to meet ripple current requirements.
- Diode D2 must be an ultra-fast type, with reverse recovery time ( $t_{rr}$ )  $\leq 50$  ns.
- Minimum recommended output voltage in this topology is 5 V.

Lower voltages may cause continuous mode operation, forcing high reverse recovery currents in D2 and therefore, lowering efficiency.

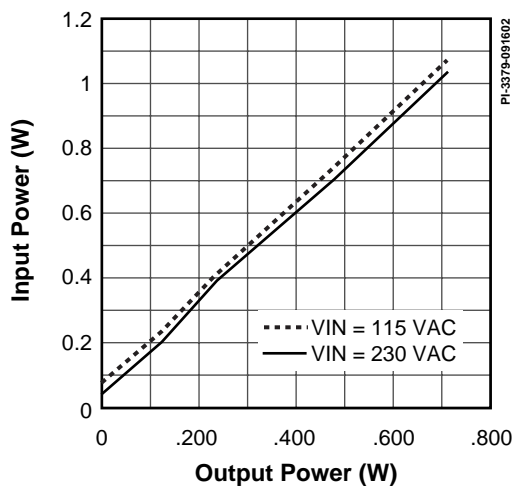

Figure 2. Output Power vs. Input Power.

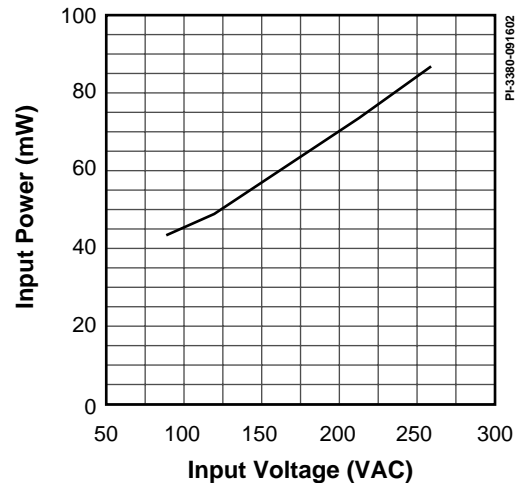

Figure 3. No-load Power Consumption.

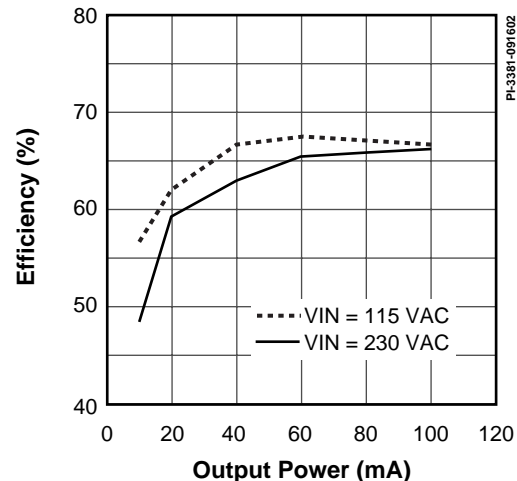

Figure 4. Efficiency vs. Output Current.

For the latest updates, visit our Web site: [www.powerint.com](http://www.powerint.com)

Power Integrations reserves the right to make changes to its products at any time to improve reliability or manufacturability.

Power Integrations does not assume any liability arising from the use of any device or circuit described herein, nor does it convey any license under its patent rights or the rights of others. The products and applications illustrated herein may be covered by one or more U.S. and foreign patents or potentially by pending U.S. and foreign patent applications assigned to Power Integrations. A complete list of Power Integrations' patents may be found at [www.powerint.com](http://www.powerint.com).

The PI Logo, **TOPSwitch**, **TinySwitch** and **EcoSmart** are registered trademarks of Power Integrations, Inc.

**PI Expert** is a trademark of Power Integrations Inc. ©Copyright 2002, Power Integrations, Inc.

### WORLD HEADQUARTERS AMERICAS

Power Integrations, Inc.  
San Jose, CA 95138 USA  
Customer Service:  
Phone: +1 408-414-9665  
Fax: +1 408-414-9765  
e-mail: [usasales@powerint.com](mailto:usasales@powerint.com)

### CHINA

Power Integrations International  
Holdings, Inc.  
China  
Phone: +86-755-8367-5143  
Fax: +86-755-8377-9610  
e-mail: [chinasales@powerint.com](mailto:chinasales@powerint.com)

### EUROPE & AFRICA

Power Integrations (Europe) Ltd.  
United Kingdom  
Phone: +44-1344-462-300  
Fax: +44-1344-311-732  
e-mail: [eurosales@powerint.com](mailto:eurosales@powerint.com)

### KOREA

Power Integrations  
International Holdings, Inc.  
Seoul, Korea  
Phone: +82-2-782-2840  
Fax: +82-2-782-4427  
e-mail: [koreasales@powerint.com](mailto:koreasales@powerint.com)

### SINGAPORE

Power Integrations, Singapore  
Republic of Singapore 308900  
Phone: +65-6358-2160  
Fax: +65-6358-2015  
e-mail: [singaporesales@powerint.com](mailto:singaporesales@powerint.com)

### JAPAN

Power Integrations, K.K.  
Keihin-Tatemono 1st Bldg.  
Japan  
Phone: +81-45-471-1021  
Fax: +81-45-471-3717  
e-mail: [japansales@powerint.com](mailto:japansales@powerint.com)

### APPLICATIONS HOTLINE

World Wide +1-408-414-9660

### TAIWAN

Power Integrations  
International Holdings, Inc.  
Taipei, Taiwan  
Phone: +886-2-2727-1221  
Fax: +886-2-2727-1223  
e-mail: [taiwansales@powerint.com](mailto:taiwansales@powerint.com)

### INDIA (Technical Support)

Innovatech  
Bangalore, India  
Phone: +91-80-226-6023  
Fax: +91-80-228-9727  
e-mail: [indiasales@powerint.com](mailto:indiasales@powerint.com)

### APPLICATIONS FAX

World Wide +1-408-414-9760

