

# AN1601

## Efficient Safety Circuit for Electronic Ballast

Prepared by: Michael BAIRANZADE  
Power Semiconductors  
Application Engineer  
MOTOROLA – SPS – TOULOUSE

### INTRODUCTION

The self oscillant circuit, commonly used in the low cost half bridge converter, is prone to thermal runaway when the fluorescent lamp does not strike. As a consequence, either the switches are over sized to sustain such a fault condition, or the circuit includes a safety network to avoid this risk. Although several schematics are usable to perform such a function, the one described in this paper is easy to implement and does not influence the normal operation of the converter.

### PROBLEM DESCRIPTION

The schematic diagram of the evaluation board given Figure 1 is built around a standard half bridge self oscillant converter to feed the lamp, together with a Power Factor Correction circuit in the front end.

This topology makes profit of the RLC series resonant network. It can indefinitely sustain the open load condition (i.e. broken filament) since there are neither a current flow nor voltage spikes in the circuit under this mode.

When the lamp runs in steady state, the current is limited essentially by the impedance of the series inductor L1 and, thanks to the free wheeling diodes connected collector to emitter, there are no voltage spikes across the power transistors.

The operation of the ballast is more complex during the start-up sequence, when the circuit operates close to the resonance built with L1/C11/C12/R18, yielding large peak collector current and high voltage at the L1/C11 node, hence across the lamp. Usually, the lamp strikes rapidly, depending upon the temperature and the peak voltage applied across the electrodes. A typical four feet long tube needs 800 V to strike, with a pre-heating time of around 500 ms for the filaments. However, at the end of life, or under worst case conditions (low line voltage, negative ambient temperature, etc...), the lamp may

not strike and the circuit will continuously operate in the start-up mode, yielding maximum losses in the power transistors. Such level of losses generates heat which, unless the devices are heavily heatsunk, will increase the die temperature above the maximum rating in a few seconds. At this moment, the transistors are exposed to a high thermal run away risk and TO220 packaged parts may blow up in less than two minutes. This time is shorter for smaller packages like the DPAK or the TO92.

### SAFETY NETWORK DESCRIPTION

The schematic given in Figure 3, partially reproduced in Figures 2a, includes a safety circuit built with R8, D10, Q4, the sense network C16, D5, C10, R17, R16 and D11 being shown in Figure 3.

Basically, the strike voltage is scaled down by the resistor divider R16 / R17 and rectified by diode D11. The capacitors C10 and C16 give a time constant to delay the action, allowing the start-up of a normal lamp for about 5 seconds. Capacitor C18 filters the gate voltage, making sure that noise will not trigger the thyristor. When the voltage across C10 exceeds the zener value of D5, the thyristor Q4 is triggered, pulling the low side of the winding T1d to ground. The Vaux voltage, supplied by the PFC, is applied across D10/R8/N4 and the DC current  $I_S$  forces the toroid into the saturation region by the extra flux coming from  $I_S * T1d$ .

Consequently, the output to base positive coupling of each transistor becomes negligible, the  $\mu_r$  being now equal to 1, and the converter stops immediately. Since the value of  $I_S$  is made larger than the holding current  $I_H$ , the SCR stays ON until the line is switched OFF: the fault is memorized and the module is fully protected.

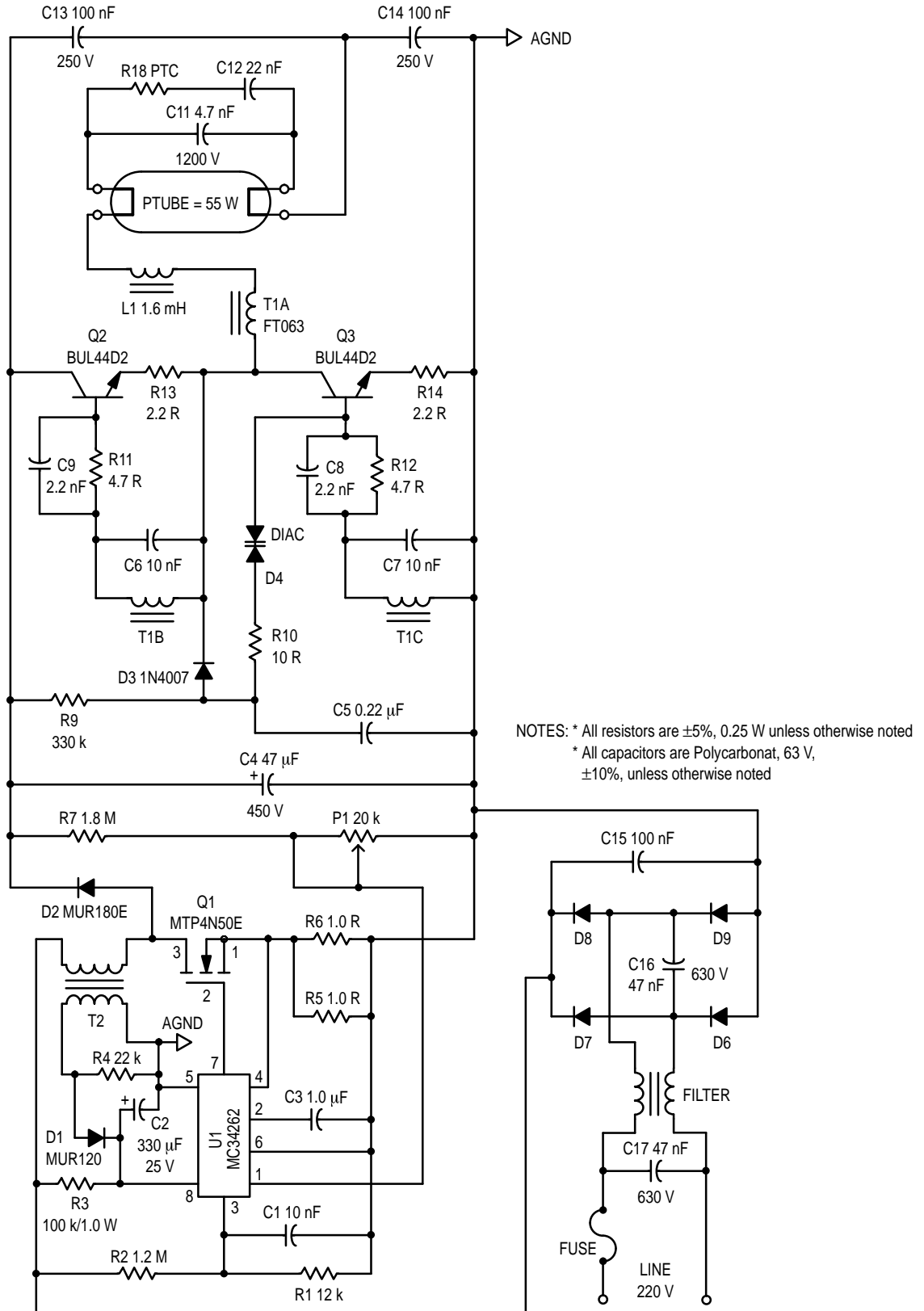

**Figure 1. Standard Half Bridge Electronic Ballast Schematic Diagram**

On the other hand,  $I_S$  shunts to ground all of the energy coming from the pre-charge resistor R3 (see Figure 3) and the Vaux winding connected across the PFC output inductor:

front end stage is switched off, since the Vaux drops below the low voltage threshold of IC, and the power dissipated by Joule's effect in R8 is negligible.

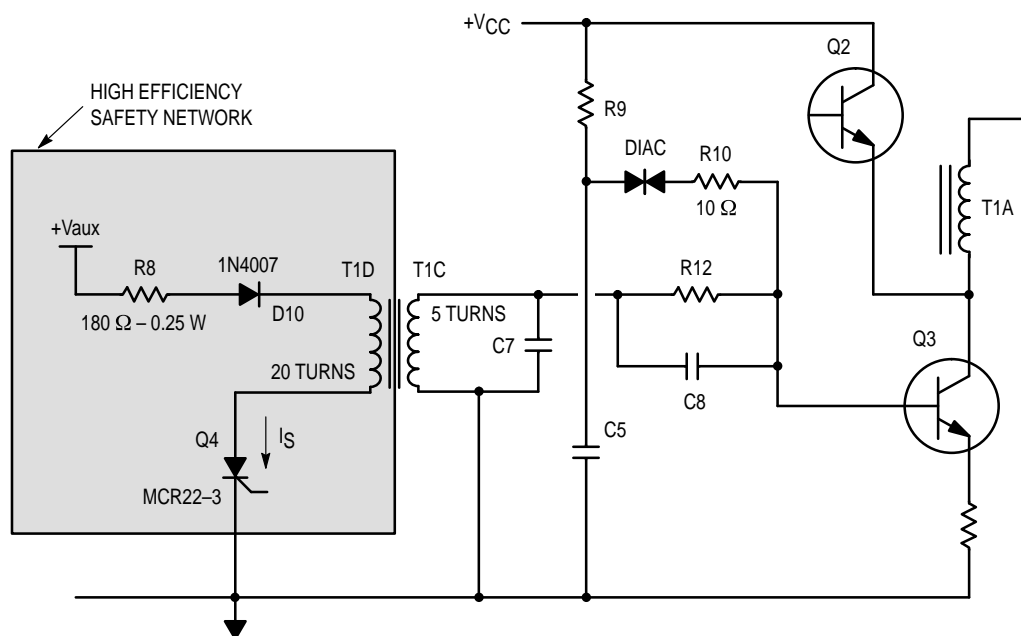

NOTE: Partial circuit, see details and references Figure 3

Figure 2a. Low Losses Safety Circuit (MOTOROLA Patent Pending)

Since a 10 mm toroid is large enough to accommodate 20 turns for T1d (AWG 32 or lower), one needs only 50 mA of DC current to saturate the toroid. These number must be recalculated for different toroid size and ferrite material.

Eventually, the start-up network can be deactivated when the safety circuit is triggered, by using two extra diodes to clamp the voltage below the trig point of the DIAC as depicted Figure 2b.

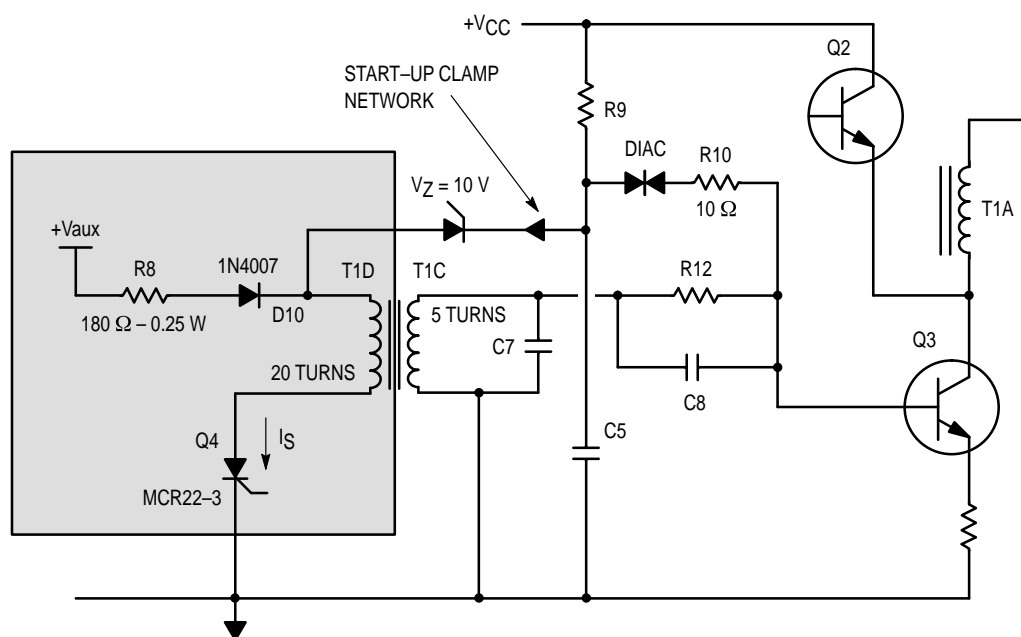

NOTE: Partial circuit, see details and references Figure 3

Figure 2b. Deactivation of the Start-up Network (MOTOROLA Patent Pending)

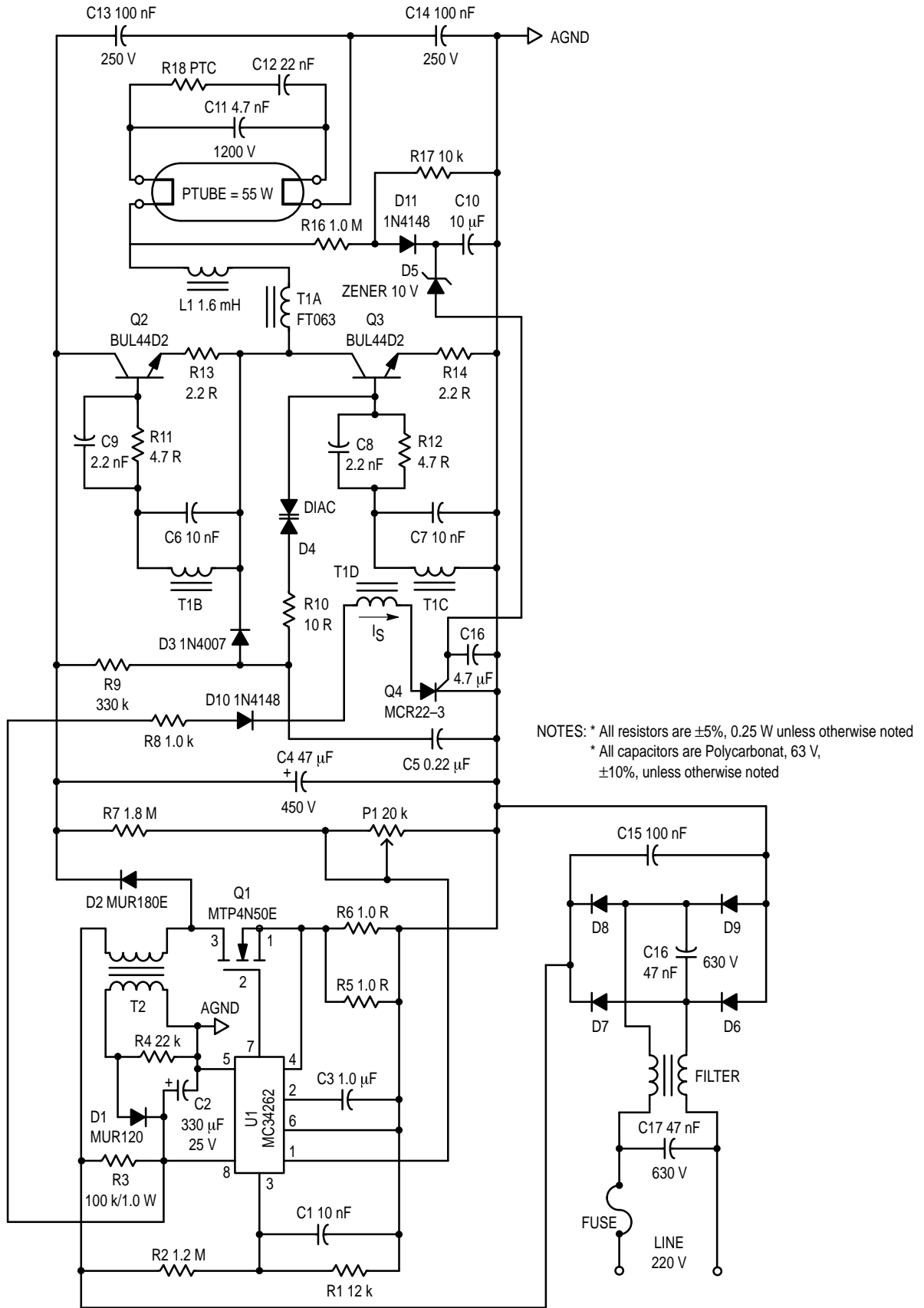

Figure 3. Typical Safety Circuit Application

If the low voltage  $V_{aux}$ , or similar, is not available (ie: module without a PFC), the current  $I_S$  can be derived from the  $V_{CC}$  line. Obviously, the components must be sized to sustain the high voltage as depicted in Figure 4. In this case, the power dissi-

pated into R becomes high and will generate enough heat to significantly increase the temperature inside the housing of the electronic circuit.

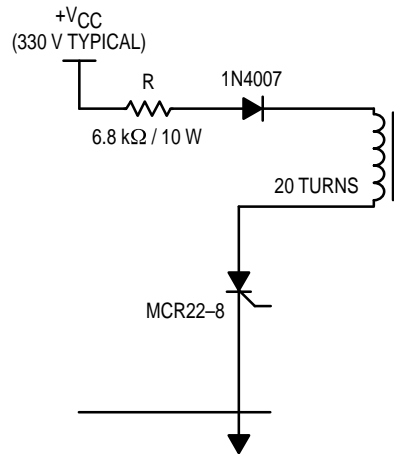

Figure 4. High Voltage Driven Safety Circuit

To overcome such a problem, the design can be improved as depicted in Figure 5. The DC current is kept at the  $I_H$  value by means of  $R_H$ , limiting the losses to less than one watt. The saturation current  $I_S$  is generated by capacitor  $C_S$  which, associated to the current limiting resistor  $R_T$ , will provide a pulse long enough to switch off the converter when the SCR is switched ON. However, once the capacitor is charged, the

DC current, flowing in  $R_H$  associated with  $R_9$ , becomes too low to maintain the saturation of the core. The clamp diode  $D_C$ , which is mandatory to avoid the re-start of the converter, provides a path for the  $I_H$  current. Consequently, the current flowing in the start-up resistor  $R_9$  is added to the one coming from  $R_H$ , limiting the wattage of that resistor by sharing the holding current.

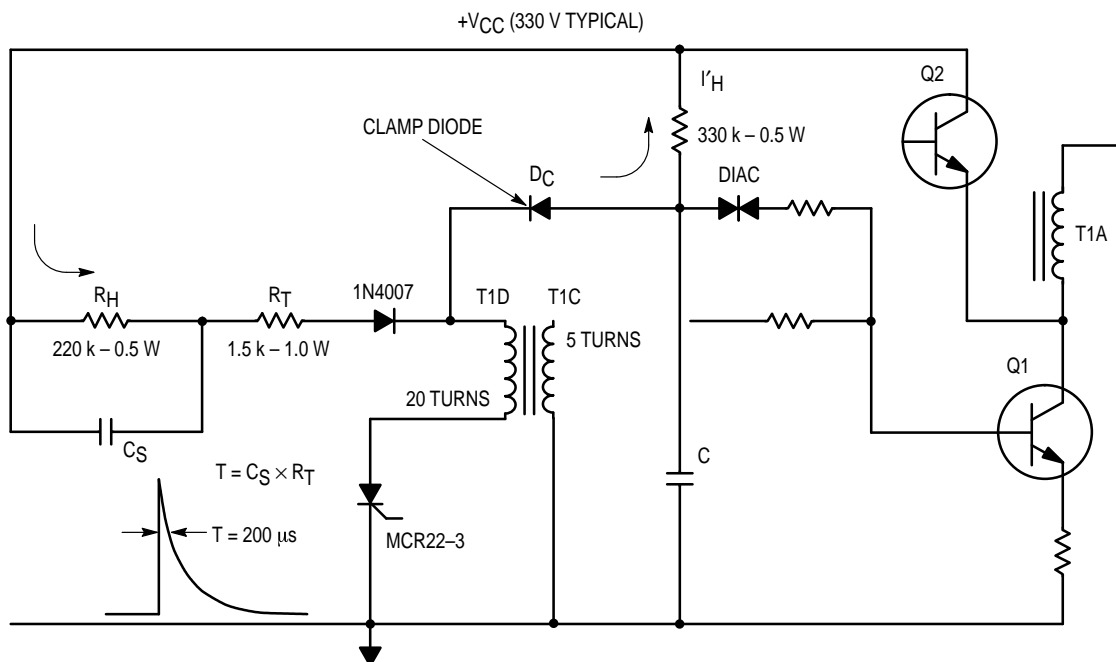

Figure 5. Improved High Voltage Driven Safety Circuit (MOTOROLA Patent Pending)

# AN1601

## CONCLUSION

The high end electronic ballasts can be designed with specific drivers which include all the requested circuits to perform the safety functions, the extra cost being masked by the overall complexity. The situation is very different with modules targeted for the low cost market where each extra penny is valuable. The safety circuits proposed in this paper are easy to implement and do not need sophisticated and costly components to protect the electronic ballasts against the most common lamp failure mode.

With the galvanic isolation from the base drive of the power transistor provided by the magnetic circuit, the safety network is free from uncontrolled feedback from one circuit to the other. On the other hand, since it dumps the permeability of the magnetic core to unity, instead of shunting one base current only, both transistors are shut off simultaneously, avoiding the risk of cross conduction during the transient phase.

## BIBLIOGRAPHY:

Michael BAIRANZADE:  
Electronic Lamp Ballast Design  
Motorola AN1543

Motorola reserves the right to make changes without further notice to any products herein. Motorola makes no warranty, representation or guarantee regarding the suitability of its products for any particular purpose, nor does Motorola assume any liability arising out of the application or use of any product or circuit, and specifically disclaims any and all liability, including without limitation consequential or incidental damages. "Typical" parameters which may be provided in Motorola data sheets and/or specifications can and do vary in different applications and actual performance may vary over time. All operating parameters, including "Typicals" must be validated for each customer application by customer's technical experts. Motorola does not convey any license under its patent rights nor the rights of others. Motorola products are not designed, intended, or authorized for use as components in systems intended for surgical implant into the body, or other applications intended to support or sustain life, or for any other application in which the failure of the Motorola product could create a situation where personal injury or death may occur. Should Buyer purchase or use Motorola products for any such unintended or unauthorized application, Buyer shall indemnify and hold Motorola and its officers, employees, subsidiaries, affiliates, and distributors harmless against all claims, costs, damages, and expenses, and reasonable attorney fees arising out of, directly or indirectly, any claim of personal injury or death associated with such unintended or unauthorized use, even if such claim alleges that Motorola was negligent regarding the design or manufacture of the part. Motorola and  are registered trademarks of Motorola, Inc. Motorola, Inc. is an Equal Opportunity/Affirmative Action Employer.

Mfax is a trademark of Motorola, Inc.

### How to reach us:

**USA/EUROPE/Locations Not Listed:** Motorola Literature Distribution;  
P.O. Box 5405, Denver, Colorado 80217. 303-675-2140 or 1-800-441-2447

**JAPAN:** Nippon Motorola Ltd.: SPD, Strategic Planning Office, 4-32-1,  
Nishi-Gotanda, Shinagawa-ku, Tokyo 141, Japan. 81-3-5487-8488

**Mfax™:** RMFAX0@email.sps.mot.com – TOUCHTONE 602-244-6609  
– US & Canada ONLY 1-800-774-1848

**ASIA/PACIFIC:** Motorola Semiconductors H.K. Ltd.; 8B Tai Ping Industrial Park,  
51 Ting Kok Road, Tai Po, N.T., Hong Kong. 852-26629298

**INTERNET:** <http://motorola.com/sps>



**MOTOROLA**



AN1601/D