

K1231EK3AH4	(LM2576-3.3)
K1231EK31AH4	(LM2576HV-3.3)
K1231EK5H4	(LM2576-5.0)
K1231EK51H4	(LM2576HV-5.0)
K1231EK12H4	(LM2576-12)
K1231EK121H4	(LM2576HV-12)
K1231EK15H4	(LM2576-15)
K1231EK151H4	(LM2576HV-15)
K1231EP1H4	(LM2576-ADJ)
K1231EP11H4	(LM2576HV-ADJ)

## SIMPLE SWITCHER 3A Step-Down Voltage Regulator



### GENERAL DESCRIPTION

The LM2576 series of regulators are monolithic integrated circuits that provide all the active functions for a step-down (buck) switching regulator, capable of driving 3A load with excellent line and load regulation. These devices are available in fixed output voltages of 3.3V, 5V, 12V, 15V, and an adjustable output versions.

Requiring a minimum number of external components, these regulators are simple to use and include internal frequency compensation and a fixed-frequency oscillator.

The LM2576 series offers a high-efficiency replacement for popular three-terminal linear regulators. It substantially reduces the size of the heat sink, and in some cases no heat sink is required.

A standard series of inductors optimized for use with the LM2576 are available from several different manufacturers. This feature greatly simplifies the design of switch-mode power supplies.

Other features include a guaranteed  $\pm 4\%$  tolerance on output voltage within specified input voltages and output load conditions, and  $\pm 10\%$  on the oscillator frequency. External shutdown is included, featuring 50 $\mu$ A (typical) standby current. The output switch includes cycle-by-cycle current limiting, as well as thermal shutdown for full protection under fault conditions.

Note: The LM2576HV is not produced yet.

### FEATURES

- 3.3V, 5V, 12V, 15V, and adjustable output versions
- Adjustable version output voltage range, 1.23V to 37V (57V for HV version)  $\pm 4\%$  max over line and load conditions
- Guaranteed 3A output current
- Wide input voltage range, 40V up to 60V for HV version
- Requires only 4 external components
- 52 kHz fixed frequency oscillator
- TTL shutdown capability, low power standby mode
- High efficiency
- Uses readily available standard inductors
- Thermal shutdown and current limit protection

### APPLICATIONS

- Simple high-efficiency step-down (buck) regulator
- Efficient pre-regulator for linear regulators
- On-card switching regulators
- Positive to negative converter (Buck-Boost)

### TYPICAL APPLICATION (Fixed Output Voltage Versions)

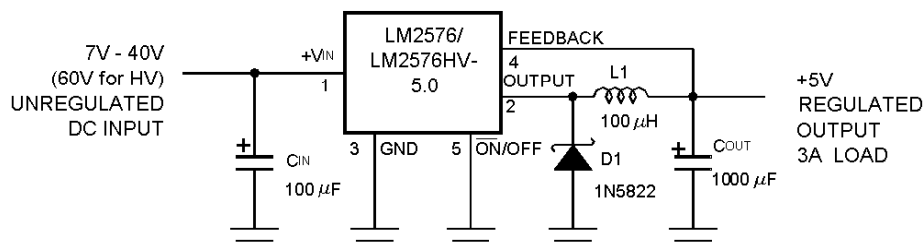

FIGURE 1.

**K1231EK3AH4 (LM2576-3.3)**  
**K1231EK31AH4 (LM2576HV-3.3)**  
**K1231EK5H4 (LM2576-5.0)**  
**K1231EK51H4 (LM2576HV-5.0)**  
**K1231EK12H4 (LM2576-12)**  
**K1231EK121H4 (LM2576HV-12)**  
**K1231EK15H4 (LM2576-15)**  
**K1231EK151H4 (LM2576HV-15)**  
**K1231EP1H4 (LM2576-ADJ)**  
**K1231EP11H4 (LM2576HV-ADJ)**

**SIMPLE SWITCHER 3A**  
**Step-Down Voltage Regulator**



**BLOCK DIAGRAM**

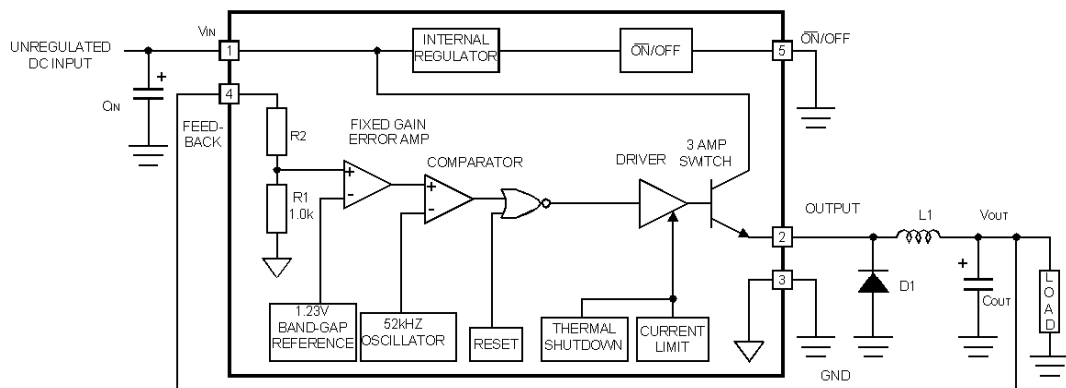

3.3V, R2 = 1.7K  
 5V, R2 = 3.1K  
 12V, R2 = 8.84K  
 15V, R2 = 11.3K  
 For ADJ, Version  
 R1 = Open, R2 = 0Ω

**ORDERING INFORMATION**

Temperature Range	Output Voltage					Package Type
	3.3	5.0	12	15	ADJ	
-40°C ≤ T <sub>A</sub> ≤ 125°C	LM2576HVS-3.3	LM2576HVS-5.0	LM2576HVS-12	LM2576HVS-15	LM2576HVS-ADJ	TO-263
	LM2576S-3.3	LM2576S-5.0	LM2576S-12	LM2576S-15	LM2576S-ADJ	
	LM2576HVT-3.3	LM2576HVT-5.0	LM2576HVT-12	LM2576HVT-15	LM2576HVT-ADJ	TO-220
	LM2576T-3.3	LM2576T-5.0	LM2576T-12	LM2576T-15	LM2576T-ADJ	

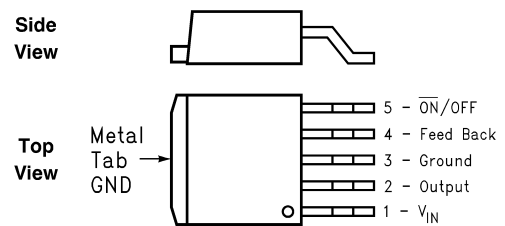
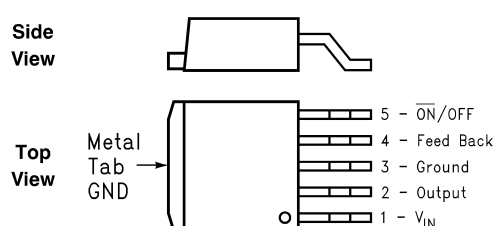

**K1231EK3AH4 (LM2576-3.3)**  
**K1231EK31AH4 (LM2576HV-3.3)**  
**K1231EK5H4 (LM2576-5.0)**  
**K1231EK51H4 (LM2576HV-5.0)**  
**K1231EK12H4 (LM2576-12)**  
**K1231EK121H4 (LM2576HV-12)**  
**K1231EK15H4 (LM2576-15)**  
**K1231EK151H4 (LM2576HV-15)**  
**K1231EP1H4 (LM2576-ADJ)**  
**K1231EP11H4 (LM2576HV-ADJ)**

**SIMPLE SWITCHER 3A**  
**Step-Down Voltage Regulator**



**Absolute Maximum Ratings (Note 1)**

Minimum ESD Rating  
 (C= 100pF, R = 1.5 kΩ) 2 kV  
 Lead Temperature  
 (Soldering, 10 Seconds) 260°C

Maximum Supply Voltage

LM2576 45V  
 LM2576HV 63V

**Operating Ratings**

Temperature Range  
 LM2576/ LM2576HV  $-40^{\circ}\text{C} \leq T_J \leq +125^{\circ}\text{C}$   
 Supply Voltage  
 LM2576 40V  
 LM2576HV 60V

ON/OFF Pin Input Voltage  $-0.3\text{V} \leq V \leq +V_{IN}$   
 Output Voltage to Ground (Steady State) -1V  
 Power Dissipation Internally Limited

Storage Temperature Range  $-65^{\circ}\text{C}$  to  $+150^{\circ}\text{C}$   
 Maximum Junction Temperature 150°C

**LM2576-3.3, LM2576HV-3.3**  
**Electrical Characteristics**

Specifications with standard type face are for  $T_J = 25^{\circ}\text{C}$ , and those with **boldface type** apply over full Operating Temperature Range.

Symbol	Parameter	Conditions	LM2576-3.3 LM2576HV-3.3		Units (Limits)
			Typ	Limit (Note 2)	
<b>SYSTEM PARAMETERS (Note 3) Test Circuit Figure 2</b>					
$V_{OUT}$	Output Voltage	$V_{IN} = 12\text{V}$ , $I_{LOAD} = 0.5\text{A}$ Circuit of Figure 2	3.3	3.234 3.366	V V(Min) V(Max)
$V_{OUT}$	Output Voltage LM2576	$6\text{V} \leq V_{IN} \leq 40\text{V}$ , $0.5\text{A} \leq I_{LOAD} \leq 3\text{A}$ Circuit of Figure 2	3.3	3.168/ <b>3.135</b> 3.432/ <b>3.465</b>	V V(Min) V(Max)
$V_{OUT}$	Output Voltage LM2576HV	$6\text{V} \leq V_{IN} \leq 60\text{V}$ , $0.5\text{A} \leq I_{LOAD} \leq 3\text{A}$ Circuit of Figure 2	3.3	3.168/ <b>3.135</b> 3.450/ <b>3.482</b>	V V(Min) V(Max)
$\eta$	Efficiency	$V_{IN} = 12\text{V}$ , $I_{LOAD} = 3\text{A}$	75		%

K1231EK3AH4 (LM2576-3.3)  
 K1231EK31AH4 (LM2576HV-3.3)  
 K1231EK5H4 (LM2576-5.0)  
 K1231EK51H4 (LM2576HV-5.0)  
 K1231EK12H4 (LM2576-12)  
 K1231EK121H4 (LM2576HV-12)  
 K1231EK15H4 (LM2576-15)  
 K1231EK151H4 (LM2576HV-15)  
 K1231EP1H4 (LM2576-ADJ)  
 K1231EP11H4 (LM2576HV-ADJ)

**SIMPLE SWITCHER 3A**  
**Step-Down Voltage Regulator**



**LM2576-5.0, LM2576HV-5.0**

**Electrical Characteristics**

Specifications with standard type face are for  $T_J = 25^\circ\text{C}$ , and those with *Figure 2 boldface type* apply over full Operating Temperature Range.

Symbol	Parameter	Conditions	LM2576-5.0 LM2576HV-5.0		Units (Limits)
			Typ	Limit (Note 2)	
<b>SYSTEM PARAMETERS (Note 3) Test Circuit Figure 2</b>					
$V_{OUT}$	Output Voltage	$V_{IN} = 12\text{V}$ , $I_{LOAD} = 0.5\text{A}$ Circuit of Figure 2	5.0	4.900 5.100	V V(Min) V(Max)
$V_{OUT}$	Output Voltage LM2576	$0.5\text{A} \leq I_{LOAD} \leq 3\text{A}$ , $8\text{V} \leq V_{IN} \leq 40\text{V}$ Circuit of Figure 2	5.0	4.800/ <b>4.750</b> 5.200/ <b>5.250</b>	V V(Min) V(Max)
$V_{OUT}$	Output Voltage LM2576HV	$0.5\text{A} \leq I_{LOAD} \leq 3\text{A}$ , $8\text{V} \leq V_{IN} \leq 60\text{V}$ Circuit of Figure 2	5.0	4.800/ <b>4.750</b> 5.225/ <b>5.275</b>	V V(Min) V(Max)
$\eta$	Efficiency	$V_{IN} = 12\text{V}$ , $I_{LOAD} = 3\text{A}$	77		%

**LM2576-12, LM2576HV-12**

**Electrical Characteristics**

Specifications with standard type face are for  $T_J = 25^\circ\text{C}$ , and those with **boldface type** apply over full Operating Temperature Range.

Symbol	Parameter	Conditions	LM2576-12 LM2576HV-12		Units (Limits)
			Typ	Limit (Note 2)	
<b>SYSTEM PARAMETERS (Note 3) Test Circuit Figure 2</b>					
$V_{OUT}$	Output Voltage	$V_{IN} = 25\text{V}$ , $I_{LOAD} = 0.5\text{A}$ Circuit of Figure 2	12	11.76 12.24	V V(Min) V(Max)
$V_{OUT}$	Output Voltage LM2576	$0.5\text{A} \leq I_{LOAD} \leq 3\text{A}$ , $15\text{V} \leq V_{IN} \leq 40\text{V}$ Circuit of Figure 2	12	11.52/ <b>11.40</b> 12.48/ <b>12.60</b>	V V(Min) V(Max)
$V_{OUT}$	Output Voltage LM2576HV	$0.5\text{A} \leq I_{LOAD} \leq 3\text{A}$ , $15\text{V} \leq V_{IN} \leq 60\text{V}$ Circuit of Figure 2	12	11.52/ <b>11.40</b> 12.54/ <b>12.66</b>	V V(Min) V(Max)
$\eta$	Efficiency	$V_{IN} = 15\text{V}$ , $I_{LOAD} = 3\text{A}$	88		%

K1231EK3AH4	(LM2576-3.3)	SIMPLE SWITCHER 3A Step-Down Voltage Regulator
K1231EK31AH4	(LM2576HV-3.3)	
K1231EK5H4	(LM2576-5.0)	
K1231EK51H4	(LM2576HV-5.0)	
K1231EK12H4	(LM2576-12)	
K1231EK121H4	(LM2576HV-12)	
K1231EK15H4	(LM2576-15)	
K1231EK151H4	(LM2576HV-15)	
K1231EP1H4	(LM2576-ADJ)	
K1231EP11H4	(LM2576HV-ADJ)	



## LM2576-15, LM2576HV-15

### Electrical Characteristics

Specifications with standard type face are for  $T_J = 25^\circ\text{C}$ , and those with **boldface type** apply over full Operating Temperature Range.

Symbol	Parameter	Conditions	LM2576-15 LM2576HV-15		Units (Limits)
			Typ	Limit (Note 2)	
<b>SYSTEM PARAMETERS</b> (Note 3) Test Circuit Figure 2					
$V_{OUT}$	Output Voltage	$V_{IN} = 25$ , $I_{LOAD} = 0.5\text{A}$ Circuit of Figure 2	15	14.70 15.30	V V(Min) V(Max)
$V_{OUT}$	Output Voltage LM2576	$0.5\text{A} \leq I_{LOAD} \leq 3\text{A}$ , $18 \leq V_{IN} \leq 40\text{V}$ Circuit of Figure 2	15	14.40/ <b>14.25</b> 15.60/ <b>15.75</b>	V V(Min) V(Max)
$V_{OUT}$	Output Voltage LM2576HV	$0.5\text{A} \leq I_{LOAD} \leq 3\text{A}$ , $18 \leq V_{IN} \leq 60\text{V}$ Circuit of Figure 2	15	14.40/ <b>14.25</b> 15.68/ <b>15.83</b>	V V(Min) V(Max)
$\eta$	Efficiency	$V_{IN} = 18\text{V}$ , $I_{LOAD} = 3\text{A}$	88		%

## LM2576-ADJ, LM2576HV-ADJ

### Electrical Characteristics

Specifications with standard type face are for  $T_J = 25^\circ\text{C}$ , and those with **boldface type** apply over full Operating Temperature Range.

Symbol	Parameter	Conditions	LM2576-ADJ LM2576HV-ADJ		Units (Limits)
			Typ	Limit (Note 2)	
<b>SYSTEM PARAMETERS</b> (Note 3) Test Circuit Figure 2					
$V_{OUT}$	Feedback Voltage	$V_{IN} = 12\text{V}$ , $I_{LOAD} = 0.5\text{A}$ , $V_{OUT} = 5\text{V}$ Circuit of Figure 2	1.230	1.217 1.243	V V(Min) V(Max)
$V_{OUT}$	Feedback Voltage LM2576	$0.5\text{A} \leq I_{LOAD} \leq 3\text{A}$ , $8\text{V} \leq V_{IN} \leq 40\text{V}$ , $V_{OUT} = 5\text{V}$ Circuit of Figure 2	1.230	1.193/ <b>1.180</b> 1.267/ <b>1.280</b>	V V(Min) V(Max)
$V_{OUT}$	Feedback Voltage LM2576HV	$0.5\text{A} \leq I_{LOAD} \leq 3\text{A}$ , $8\text{V} \leq V_{IN} \leq 60\text{V}$ , $V_{OUT} = 5\text{V}$ Circuit of Figure 2	1.230	1.193/ <b>1.180</b> 1.273/ <b>1.286</b>	V V(Min) V(Max)
$\eta$	Efficiency	$V_{IN} = 12\text{V}$ , $I_{LOAD} = 3\text{A}$ , $V_{OUT} = 5\text{V}$	77		%

**K1231EK3AH4 (LM2576-3.3)**  
**K1231EK31AH4 (LM2576HV-3.3)**  
**K1231EK5H4 (LM2576-5.0)**  
**K1231EK51H4 (LM2576HV-5.0)**  
**K1231EK12H4 (LM2576-12)**  
**K1231EK121H4 (LM2576HV-12)**  
**K1231EK15H4 (LM2576-15)**  
**K1231EK151H4 (LM2576HV-15)**  
**K1231EP1H4 (LM2576-ADJ)**  
**K1231EP11H4 (LM2576HV-ADJ)**

**SIMPLE SWITCHER 3A**  
**Step-Down Voltage Regulator**



**All Output Voltage Versions**  
**Electrical Characteristics**

Specifications with standard type face are for  $T_J = 25^\circ\text{C}$ , and those with **boldface type** apply over full Operating Temperature Range. Unless otherwise specified,  $V_{IN} = 12\text{V}$  for the 3.3V, 5V, and Adjustable version,  $V_{IN} = 25\text{V}$  for the 12V version, and  $V_{IN} = 30\text{V}$  for the 15V version, ,  $I_{LOAD} = 500\text{mA}$ .

Symbol	Parameter	Conditions	LM2576-XX LM2576HV-XX		Units (Limits)
			Typ	Limit (Note 2)	
<b>DEVICE PARAMETERS</b>					
$I_b$	Feedback Bias Current	$V_{OUT} = 5\text{V}$ (Adjustable Version Only)	50	100/ <b>500</b>	nA
$f_o$	Oscillator Frequency	(Note 8)	52	47/ <b>42</b> 58/ <b>63</b>	kHz kHz (Min) kHz (Max)
$V_{SAT}$	Saturation Voltage	$I_{OUT} = 3\text{A}$ (Note 4)	1.4	1.8/ <b>2.0</b>	V V(Max)
DC	Max Duty Cycle (ON)	(Note 5)	98	93	% %(Min)
$I_{CL}$	Current Limit	(Notes 4, 8)	5.8	4.2/ <b>3.5</b> 6.9/ <b>7.5</b>	A A(Min) A(Max)
$I_L$	Output Leakage Current	(Notes 6, 7): Output = 0V Output = -1V Output = -1V	7.5	2 30	mA(Max) mA mA(Max)
$I_Q$	Quiescent Current	(Note 6)	5	10	mA mA(Max)
$I_{STBY}$	Standby Quiescent Current	$\overline{ON}/\text{OFF}$ Pin = 5V (OFF)	50	200	$\mu\text{A}$ $\mu\text{A}(\text{Max})$

K1231EK3AH4	(LM2576-3.3)	<b>SIMPLE SWITCHER 3A Step-Down Voltage Regulator</b>
K1231EK31AH4	(LM2576HV-3.3)	
K1231EK5H4	(LM2576-5.0)	
K1231EK51H4	(LM2576HV-5.0)	
K1231EK12H4	(LM2576-12)	
K1231EK121H4	(LM2576HV-12)	
K1231EK15H4	(LM2576-15)	
K1231EK151H4	(LM2576HV-15)	
K1231EP1H4	(LM2576-ADJ)	
K1231EP11H4	(LM2576HV-ADJ)	



## All Output Voltage Versions

### Electrical Characteristics (Continued)

Specifications with standard type face are for  $T_J = 25^\circ\text{C}$ , and those with **boldface type** apply over full Operating Temperature Range. Unless otherwise specified,  $V_{IN} = 12\text{V}$  for the 3.3V, 5V, and Adjustable version,  $V_{IN} = 25\text{V}$  for the 12V version, and  $V_{IN} = 30\text{V}$  for the 15V version,  $I_{LOAD} = 500\text{mA}$ .

Symbol	Parameter	Conditions	LM2576-XX LM2576HV-XX		Units (Limits)
			Typ	Limit (Note 2)	
<b>ON/OFF CONTROL</b>					
$V_{IH}$	$\overline{\text{ON/OFF}}$ Pin	$V_{OUT} = 0\text{V}$	1.4	2.2/ <b>2.4</b>	V(Min)
$V_{IL}$	Logic Input Level	$V_{OUT} = \text{Nominal Output Voltage}$	1.2	1.0/ <b>0.8</b>	V(Max)
$I_{IH}$	$\overline{\text{ON/OFF}}$ Pin Input Current	$\overline{\text{ON/OFF}}$ Pin = 5V (OFF)	12	30	$\mu\text{A}$ $\mu\text{A}(\text{Max})$
$I_{IL}$		$\overline{\text{ON/OFF}}$ Pin = 0V (ON)	0	10	$\mu\text{A}$ $\mu\text{A}(\text{Max})$

**Note 1:** Absolute Maximum Ratings indicate limits beyond which damage to the device may occur. Operating Ratings indicate conditions for which the device is intended to be functional, but do not guarantee specific performance limits. For guaranteed specifications and test conditions, see the Electrical Characteristics.

**Note 2:** All limits guaranteed at room temperature (standard type face) and at temperature extremes (bold type face).

**Note 3:** External components such as the catch diode, inductor, input and output capacitors can affect switching regulator system performance. When the LM2576/LM2576HV is used as shown in the *Figure 2* test circuit, system performance will be as shown in system parameters section of Electrical Characteristics.

**Note 4:** Output pin sourcing current. No diode, inductor or capacitor connected to output.

**Note 5:** Feedback pin removed from output and connected to 0V.

**Note 6:** Feedback pin removed from output and connected to +12V for the Adjustable, 3.3V, and 5V, versions, and +25V for the 12V and 15V versions, to force the output transistor OFF.

**Note 7:**  $V_{IN} = 40\text{V}$  (60V for high voltage version).

**Note 8:** The oscillator frequency reduces to approximately 11 kHz in the event of an output short or an overload which causes the regulated output voltage to drop approximately 40% from the nominal output voltage. This self protection feature lowers the average power dissipation of the IC by lowering the minimum duty cycle from 5% down to approximately 2%.

**K1231EK3AH4 (LM2576-3.3)**  
**K1231EK31AH4 (LM2576HV-3.3)**  
**K1231EK5H4 (LM2576-5.0)**  
**K1231EK51H4 (LM2576HV-5.0)**  
**K1231EK12H4 (LM2576-12)**  
**K1231EK121H4 (LM2576HV-12)**  
**K1231EK15H4 (LM2576-15)**  
**K1231EK151H4 (LM2576HV-15)**  
**K1231EP1H4 (LM2576-ADJ)**  
**K1231EP11H4 (LM2576HV-ADJ)**

**SIMPLE SWITCHER 3A**  
**Step-Down Voltage Regulator**



**Typical Performance Characteristics (Circuit of Figure 2)**

**Normalized Output Voltage**

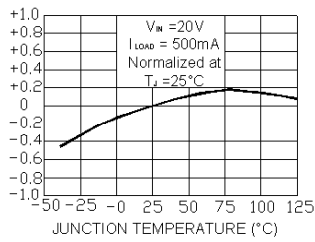

**Line Regulation**

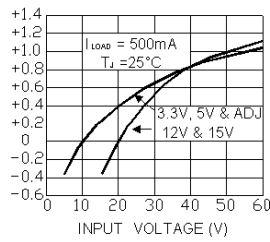

**Dropout Voltage**

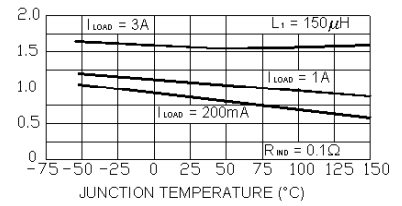

**Standby Quiescent Current**

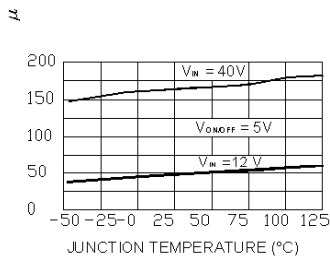

**Quiescent Current**

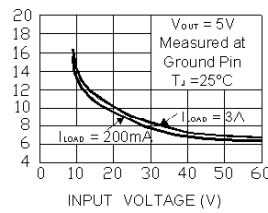

**Current Limit**

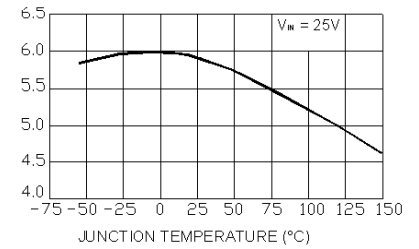

**Switch Saturation Voltage**

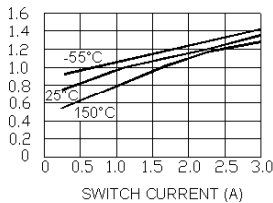

**Efficiency**

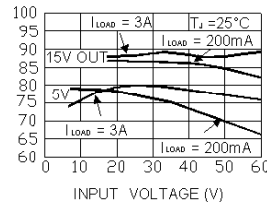

**Oscillator Frequency**

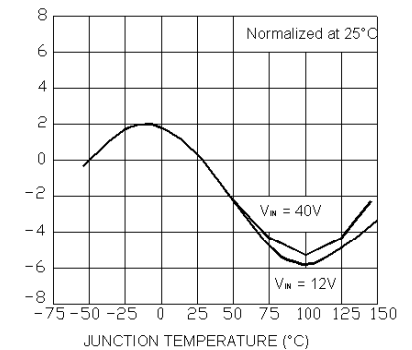



**K1231EK3AH4 (LM2576-3.3)**  
**K1231EK31AH4 (LM2576HV-3.3)**  
**K1231EK5H4 (LM2576-5.0)**  
**K1231EK51H4 (LM2576HV-5.0)**  
**K1231EK12H4 (LM2576-12)**  
**K1231EK121H4 (LM2576HV-12)**  
**K1231EK15H4 (LM2576-15)**  
**K1231EK151H4 (LM2576HV-15)**  
**K1231EP1H4 (LM2576-ADJ)**  
**K1231EP11H4 (LM2576HV-ADJ)**

**SIMPLE SWITCHER 3A**  
**Step-Down Voltage Regulator**



**Typical Performance Characteristics** (Circuit of Figure 2) (Continued)

**Minimum Operating Voltage**

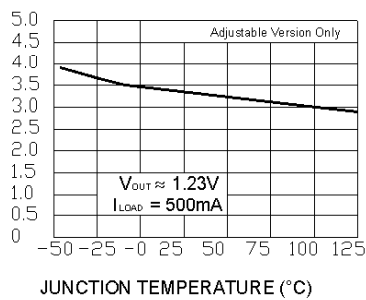

**Quiescent Current vs Duty Cycle**

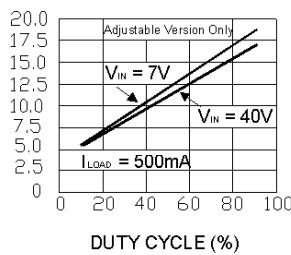

**Feedback Voltage vs Duty Cycle**

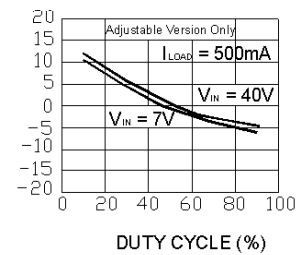

**Maximum Power Dissipation (TO-263)**

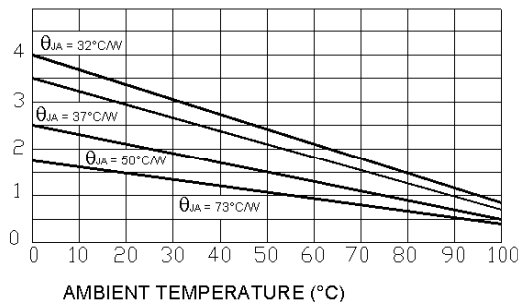

**Feedback Pin Current**

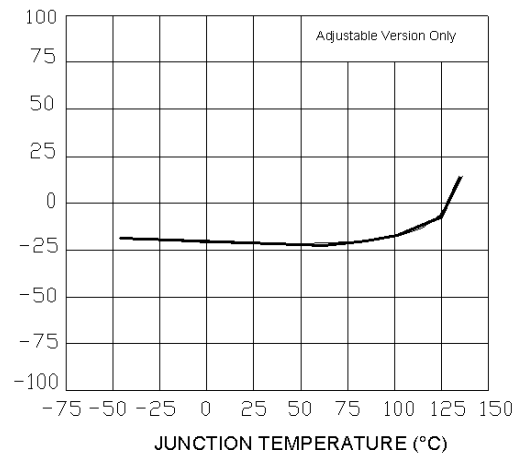

K1231EK3AH4	(LM2576-3.3)
K1231EK31AH4	(LM2576HV-3.3)
K1231EK5H4	(LM2576-5.0)
K1231EK51H4	(LM2576HV-5.0)
K1231EK12H4	(LM2576-12)
K1231EK121H4	(LM2576HV-12)
K1231EK15H4	(LM2576-15)
K1231EK151H4	(LM2576HV-15)
K1231EP1H4	(LM2576-ADJ)
K1231EP11H4	(LM2576HV-ADJ)

**SIMPLE SWITCHER 3A**  
**Step-Down Voltage Regulator**



**Typical Performance Characteristics** (Circuit of Figure 2) (Continued)

Switching Waveforms

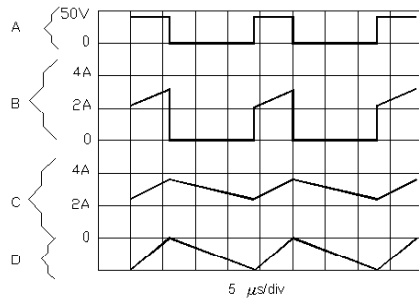

Load Transient Response

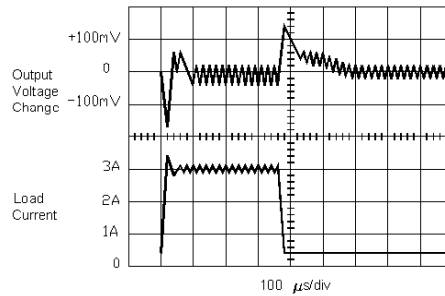

$V_{OUT} = 15V$

A: Output Pin Voltage, 50V/div

B: Output Pin Current, 2A/div

C: Inductor Current, 2A/div

D: Output Ripple Voltage, 50mV/div,

AC-Coupled

**Horizontal Time Base: 5μs/div**

K1231EK3AH4	(LM2576-3.3)
K1231EK31AH4	(LM2576HV-3.3)
K1231EK5H4	(LM2576-5.0)
K1231EK51H4	(LM2576HV-5.0)
K1231EK12H4	(LM2576-12)
K1231EK121H4	(LM2576HV-12)
K1231EK15H4	(LM2576-15)
K1231EK151H4	(LM2576HV-15)
K1231EP1H4	(LM2576-ADJ)
K1231EP11H4	(LM2576HV-ADJ)

**SIMPLE SWITCHER 3A**  
**Step-Down Voltage Regulator**



**Test Circuit and Layout Guidelines**

As in any switching regulator, layout is very important. Rapidly switching currents associated with wiring inductance generate voltage transients which can cause problems. For minimal inductance and ground loops, the length of the leads indicated by heavy lines should be kept as short as possible.

Single-point grounding (as indicated) or ground plane construction should be used for best results. When using the Adjustable version, physically locate the programming resistors near the regulator, to keep the sensitive feedback wiring short.

**Fixed Output Voltage Versions**

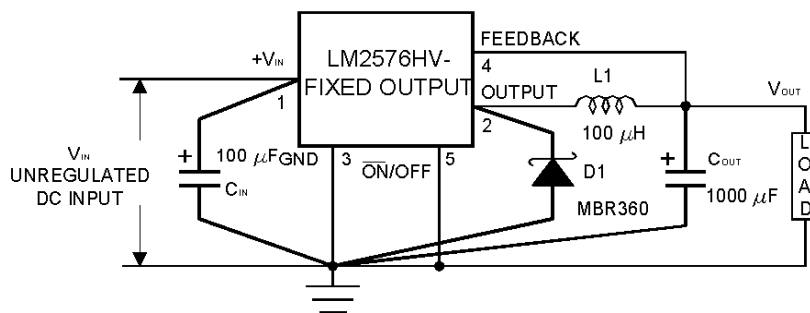

- C<sub>IN</sub> — 100μF, 75V, Aluminum Electrolytic
- C<sub>OUT</sub> — 1000μF, 25V, Aluminum Electrolytic
- D1 — Schottky, MBR360
- L<sub>1</sub> — 100μH, Pulse Eng. PE-92108
- R<sub>1</sub> — 2k, 0.1%
- R<sub>2</sub> — 6.12k, 0.1%

**Adjustable Output Voltage Version**

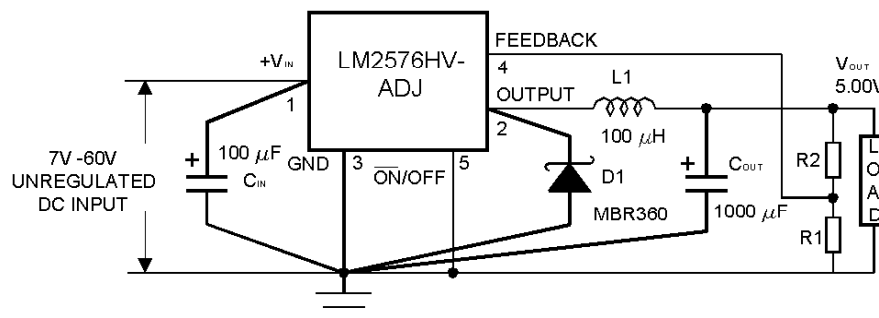

$$V_{OUT} = V_{REF} \left(1 + \frac{R_2}{R_1}\right)$$

$$R_2 = R_1 \left(\frac{V_{OUT}}{V_{REF}} - 1\right)$$

where V<sub>REF</sub> = 1.23V, R<sub>1</sub> between 1k and 5k

**FIGURE 2.**

K1231EK3AH4	(LM2576-3.3)	<b>SIMPLE SWITCHER 3A</b>
K1231EK31AH4	(LM2576HV-3.3)	<b>Step-Down Voltage Regulator</b>
K1231EK5H4	(LM2576-5.0)	
K1231EK51H4	(LM2576HV-5.0)	
K1231EK12H4	(LM2576-12)	
K1231EK121H4	(LM2576HV-12)	
K1231EK15H4	(LM2576-15)	
K1231EK151H4	(LM2576HV-15)	
K1231EP1H4	(LM2576-ADJ)	
K1231EP11H4	(LM2576HV-ADJ)	



**PAD LOCATION**

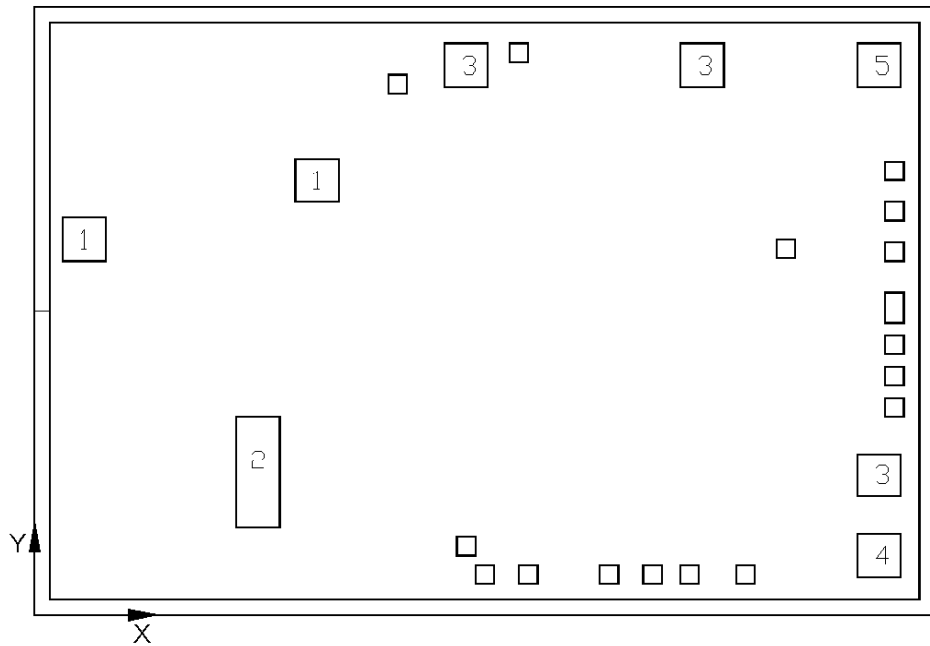

Chip Size 3.95x2.65mm

**Pad Location Coordinates**  
(Pad Centers)

NPad	Coordinates (um)	
	X	Y
1	220.5	1640
1	1244	1900
2	985.5	619.5
3	1893.5	2399
3	2935	2403
3	3716.5	603.5
4	3716.5	254
5	3716.5	2399

Pad size (um)

1,3,4,5	190x190
2	190x500