

GENERAL DESCRIPTION

The N3856V is a low cost , high efficiency, full featured ,synchronous rectification controller that specifically designed for the synchronous rectification applications of the Flyback AC/DC PWM mode switching power supply .

The N3856V is included a totem pole output ideally suited for driving a synchronous rectification power MOSFET . 2 way of the current detect provided for wide applications by any continuous or discontinuous mode operating (patent pending).In continuous mode operating, it included a timing control to adjust maximum turn-on duty to allow the designer to determine the optimal condition for the best efficiency by the external resistor and capacitor. In discontinuous mode operating, it included a very sensitive current detector (about 20mV) to control the synchronous rectification MOSFET,avoid happening a large reverse current via the synchronous rectification MOSFET to damage the device.

FEATURES

- ▲ High efficiency operating.
- ▲ Adjustable Max. duty cycle designed.
- ▲ Decrease areas of heatsink or PCB.
- ▲ Solved heat dissipation .
- ▲ Sensitive current detector(about 20mV)
- ▲ Suited for continuous and discontinuous mode operation .
- ▲ Auto frequency tracking with PWM frequency.
- ▲ Suited for fixed or variable frequency
- ▲ SOP-8 package .

APPLICATION

- Flyback AC/DC power supply

ABSOLUTE MAXIMUM RATING

PARAMETERS	SYMBOL	LIMITS	UNITS
Vcc to GND	Vcc	-0.3 to 30	V
Drain to Other Pin		180	V
Power Dissipation at Ta = 25 ,Derate 8mW/ for Ta 25	Pd	725	mW
Operating Junction Temperature Range	Tj	-40 to 150	
Storage Temperature Range	TSTG	-65 to +150	
Lead Temperture(Soldering) 10 sec	TLEAD	300	

ELECTRICAL CHARACTERISTICS (T_C = 25 °C)

PARAMETER	TEST CONDITIONS	LIMITS			UNIT
		MIN	TYP	MAX	
Supply Voltage	V _{cc}	7	12	30	V
Supply Current		-	4.5	-	mA
GATE Sink Current			1		A
GATE Source Current			1		A
Rise Time	C _L = 1.0nF		40		nS
Fall Time	C _L = 1.0nF		40		nS
Delay Time			300	400	nS
Max Duty Cycle		90	95		%

BLOCK DIAGRAM

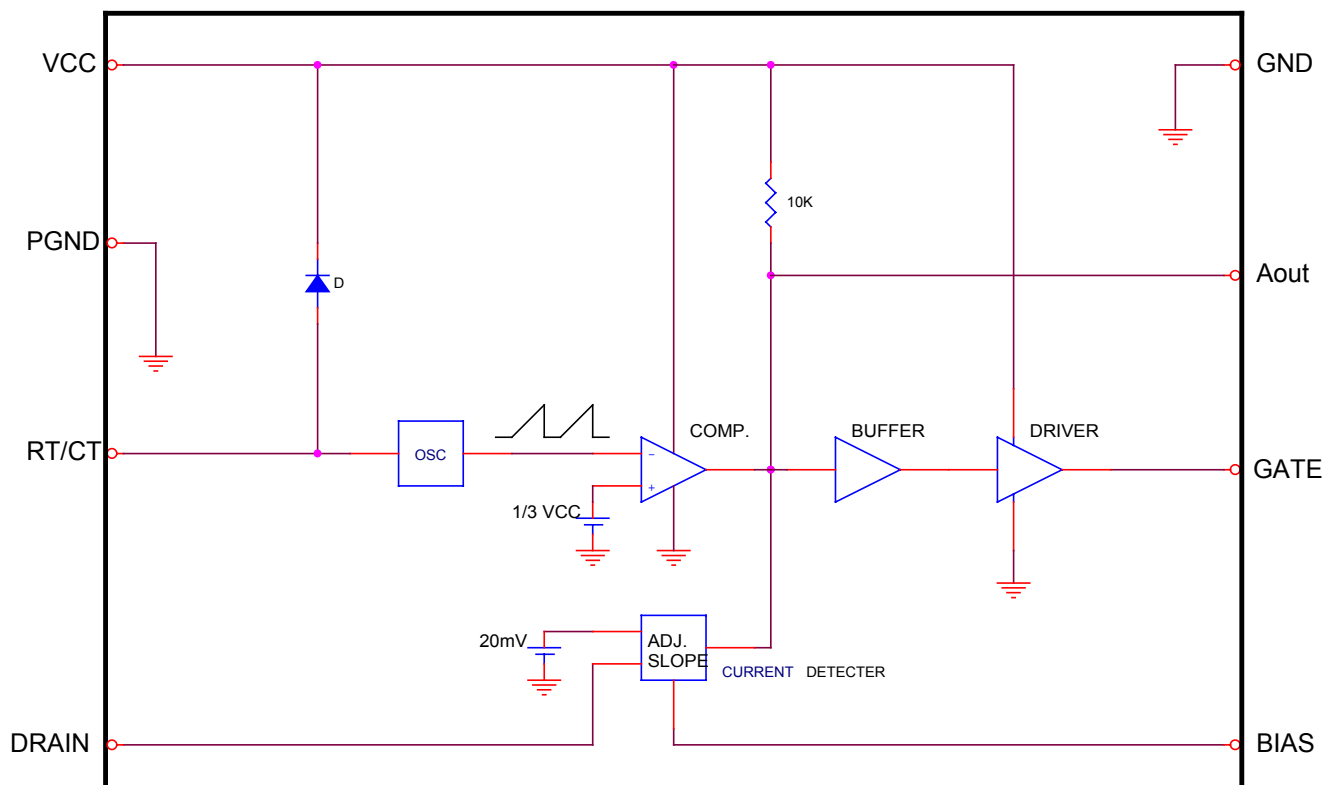

OPERATION DESCRIPTION

•Discontinuous mode

In discontinuous mode application, the N3856V is detecting the MOSFET current to control the MOSFET be ON or OFF by a internal current detector , in discontinuous mode , the current of the secondary winding flows through the Source and Drain of the MOSFET is changing from maximum level to zero , It cause a voltage drop of the MOSFET from the maximum level down to zero , the voltage drop is compared with internal reference voltage 20mV, if voltage dropout is over 20mV ,will make the MOSFET turn-on, if the voltage drop is under 20mV, will make the MOSFET become turn-off.

For the various MOSFET applications , different $R_{DS(ON)}$ will cause a different voltage drop between the MOSFET,s Source and Drain , the BIAS pin provided the “adjustable slope” function delaying turn-off the MOSFET for better efficiency , BIAS pin connected a resistor with VCC used to adjust the gate output slope , change the resistance will get the different slope ,a higher resistance will get the smoother slope, and MOSFET turn-off become slower , a smaller resistance will get the sharper slope , and MOSFET turn-off become quicker .

Considering of Bias setting, first, adjust output to heavy load but still in discontinuous mode , changing the Bias resistor make the Gate waveform of MOSFET is sloping to connect the resonant waveform of LC tank of the output circuit, second,adjust output to the minimum load and check the Gate waveform is OK or not , to decrease the resistance until waveform is normal .

•Continuous mode

In continuous mode application , the current detector can not turn-off the MOSFET directly, the N3856V provided two way to turn off the MOSFET in good time, one is the “maximum duty control” function by RT/CT ,In low line AC input voltage and maximum loading to adjust RTor CT will determine the maximum duty and timely turn off the MOSFET, another is using a synchronous signal from the primary side to control the Aout pin , pull Aout pin to low will turn off the output of Gate driver . Aout pin can be used to increase Gate drive capability when two parallel MOSFET application , connected a resistor to VCC if need .

TYPICAL APPLICATION CIRCUIT

a. Non-synchronous signal type

The non-synchronous signal type is designed for a low cost flyback power supply . The structure is suggested to design in discontinuous mode for high line input voltage and low line input voltage in continuous mode that can get better efficiency for full range input design .

In this structure, to select small tolerance(1~2%) of some components will be necessary, such as RT/CT of N3856V,and the frequency components Rt / Ct of the PWM controller . Otherwise , it may cause Q1and Q2 turn-on at same time.

Dead time = T_{turn off time} (1-Total Tol.%) - Delay time - T_{duty}

T_{duty} : duty variation from the AC ripple volatage

Total Tol.%= (Controller +Rt +Ct +RT+CT)Tol.%

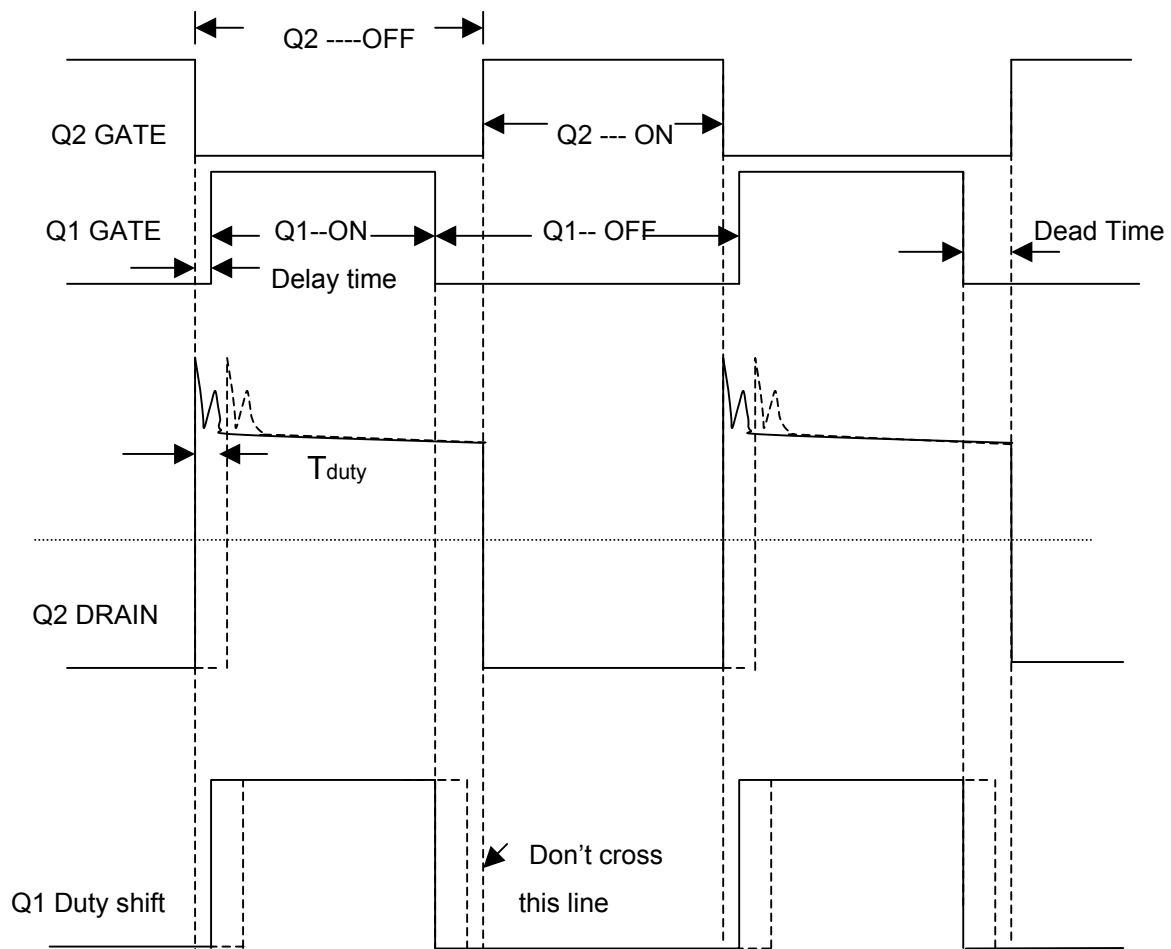

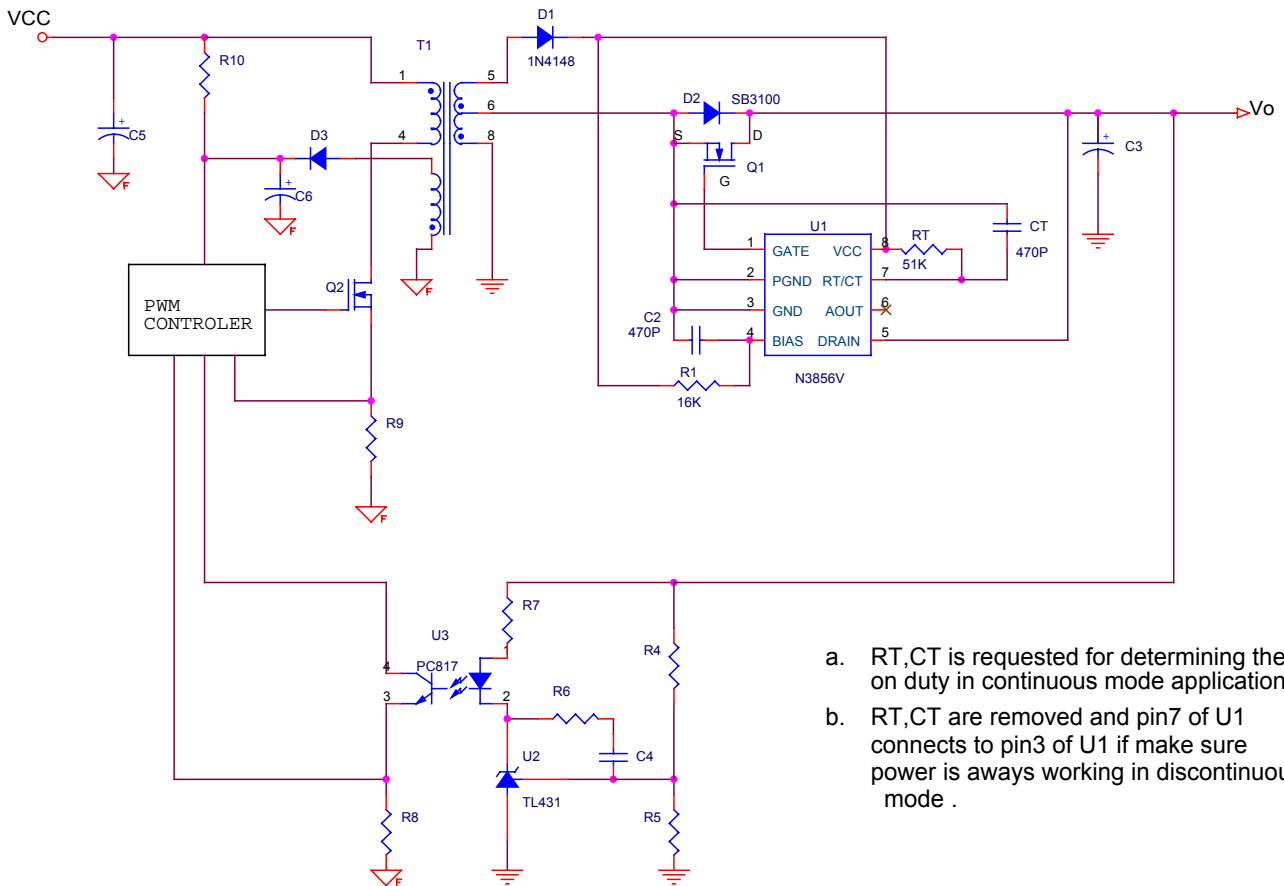

- a. RT,CT is requested for determining the turn on duty in continuous mode applications.
- b. RT,CT are removed and pin7 of U1 connects to pin3 of U1 if make sure power is always working in discontinuous mode .

Schematic 1 Non-synchronous signal type with AUX winding application

Schematic 1 is a non-synchronous signal type with AUX winding application , the AUX winding is designed to provide the supply voltage about 10V ~15V , the supply voltage via the diode D1 to VCC of the U1 without any capacitor .

In the continous mode, to change the values of the external resistor RT and capacitor CT that can set the fixed maximum turn-on duty for the synchronous rectification MOSFET.

In the discontinuous mode , current detect pin5 can sense the voltage drop of the MOSFET , if it is under 20mV ,this IC will turn off the MOSFET .

b. Synchronous signal from primary side

The structure is designed for a high power , high performance flyback power supply , the synchronous signal is provided before the MOSFET Q2 turn on from the triangle wave of the PWM controller , it need to use a isolation transformer between the primary and the secondary for safety request .when the circuit is designed in continuous mode , the MOSFET of the secondary side to be turned off by a synchronous signal from the primary side , if works in discontinuous mode that turned off by the current detect pin5 to sense the voltage drop between the source and drain of the MOSFET .

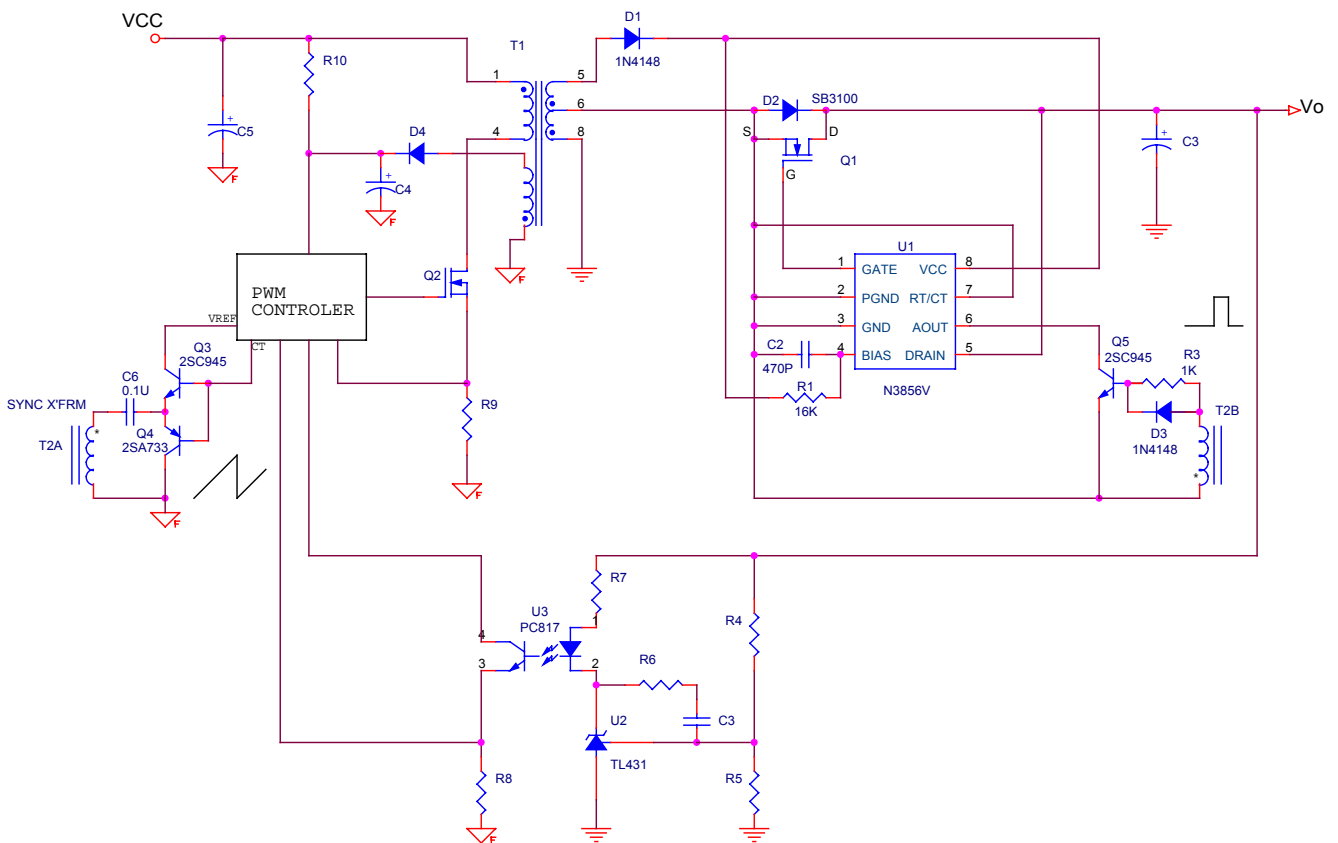

Schematic 2 synchronous signal type with AUX winding application

Schematic 2 is a synchronous signal type with AUX winding application ,in this application , the pin Cext is connected to pin3 of this IC to cancel maximum turn on duty function because the MOSFET can get best control from the synchronous signal .

TYPICAL CHARACTERISTICS

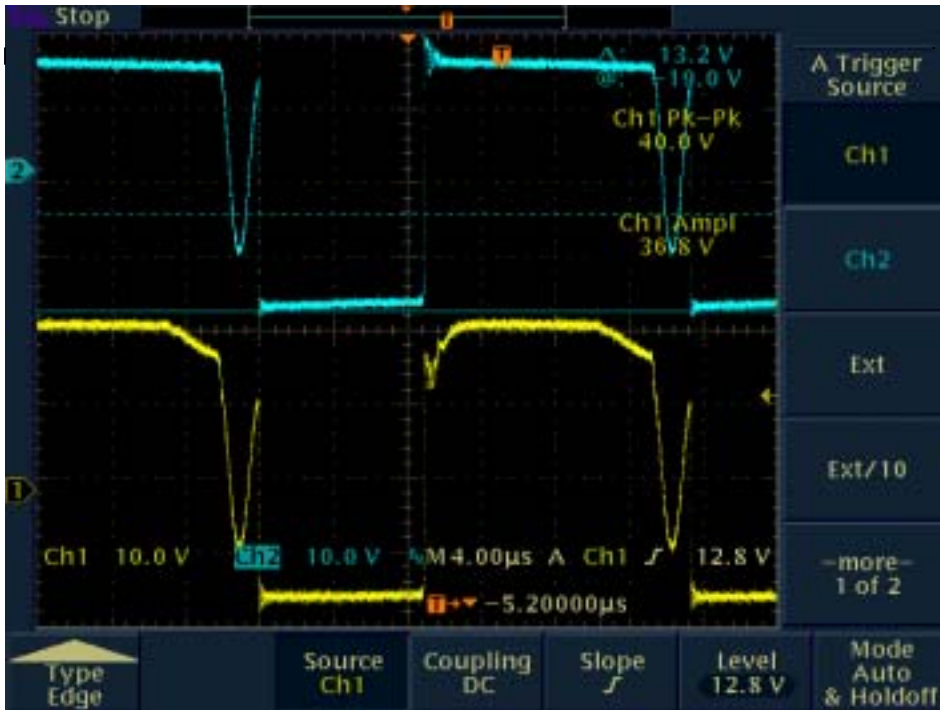

pic.1 secondary winding output and gate voltage of MOSFET waveform at discontinuous mode condition .

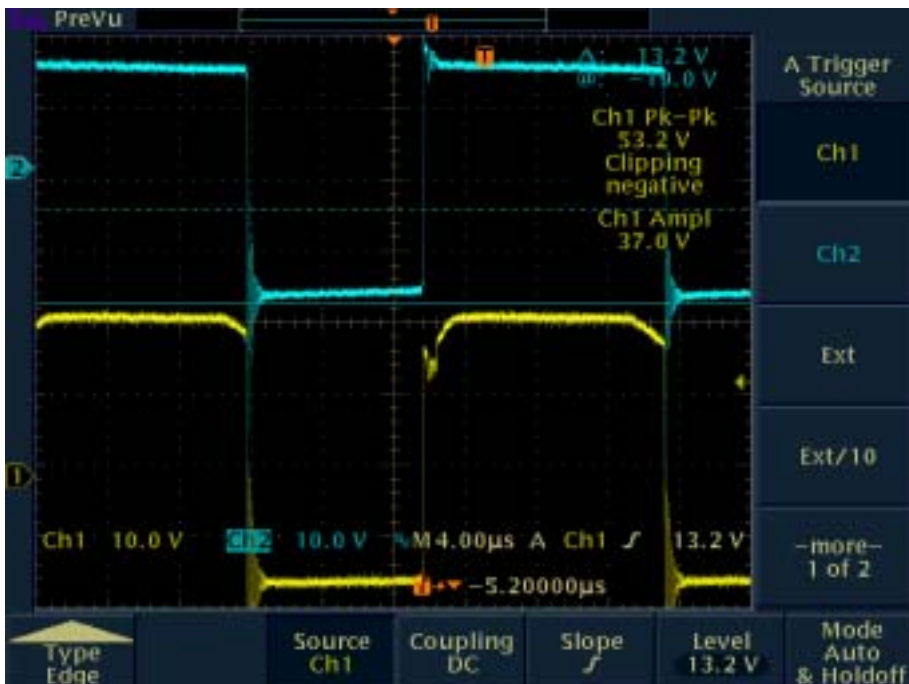

pic.2 secondary winding output and gate voltage of MOSFET waveform at continuous mode condition .



pic.3 secondary winding output and gate voltage of MOSFET waveform at no load condition .

PIN CONFIGURATIONS

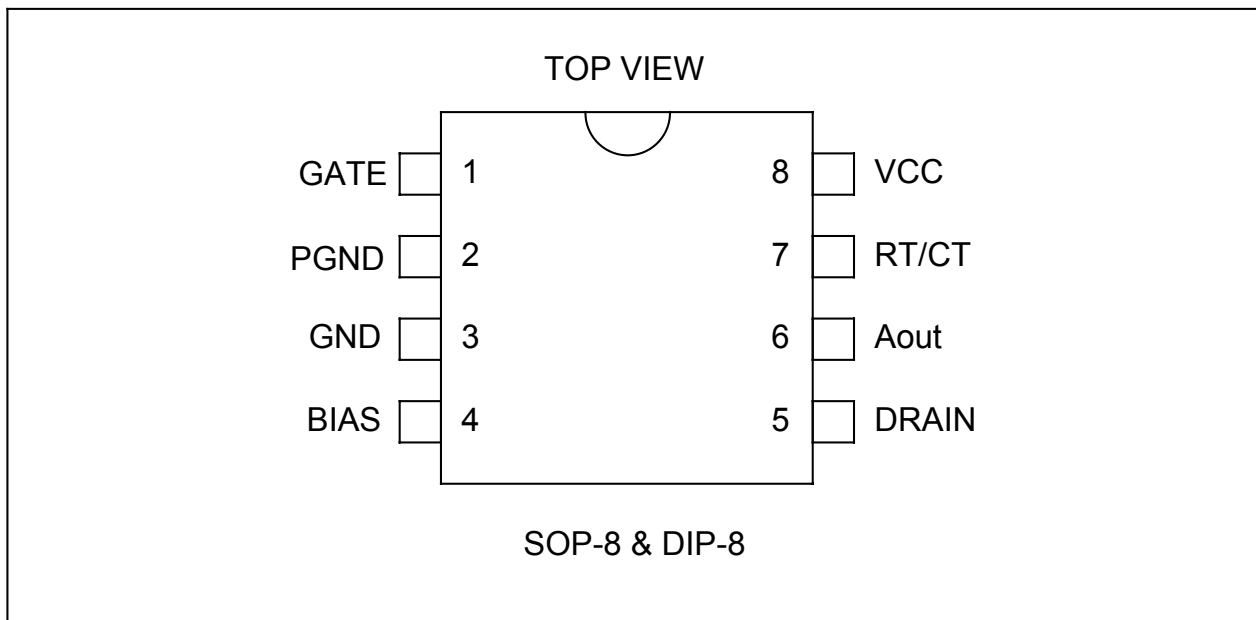

PIN FUNCTIONS

NO.	FUNCTION	DESCRIPTION
1	GATE	This pin is the output pin to drive the gate of the power MOSFET.
2	PGND	This pin is to POWER GND for output drive circuit .
3	GND	This is signal GND pin for the control logic signals .
4	BIAS	This pin is bias voltage supply for the internal current detector .
5	DRAIN	Input pin of the internal current detector , connect to drain of MOSFET .
6	Aout	This pin is internal comparator output to control “pin1” output duty.
7	RT/CT	This pin is connected a external resistor and capacitor to set the fixed maximum turn-on duty ..
8	VCC	This pin is for supply voltage .

SOIC-8 (D) MECHANICAL DATA

Dimension	mm			Dimension	mm		
	Min.	Typ.	Max.		Min.	Typ.	Max.
A	4.8	4.9	5.0	H	0.5	0.715	0.83
B	3.8	3.9	4.0	I	0.18	0.254	0.25
C	5.8	6.0	6.2	J		0.22	
D	0.38	0.445	0.51	K	0°	4°	8°
E		1.27		L			
F	1.35	1.55	1.75	M			
G	0.1	0.175	0.25	N			

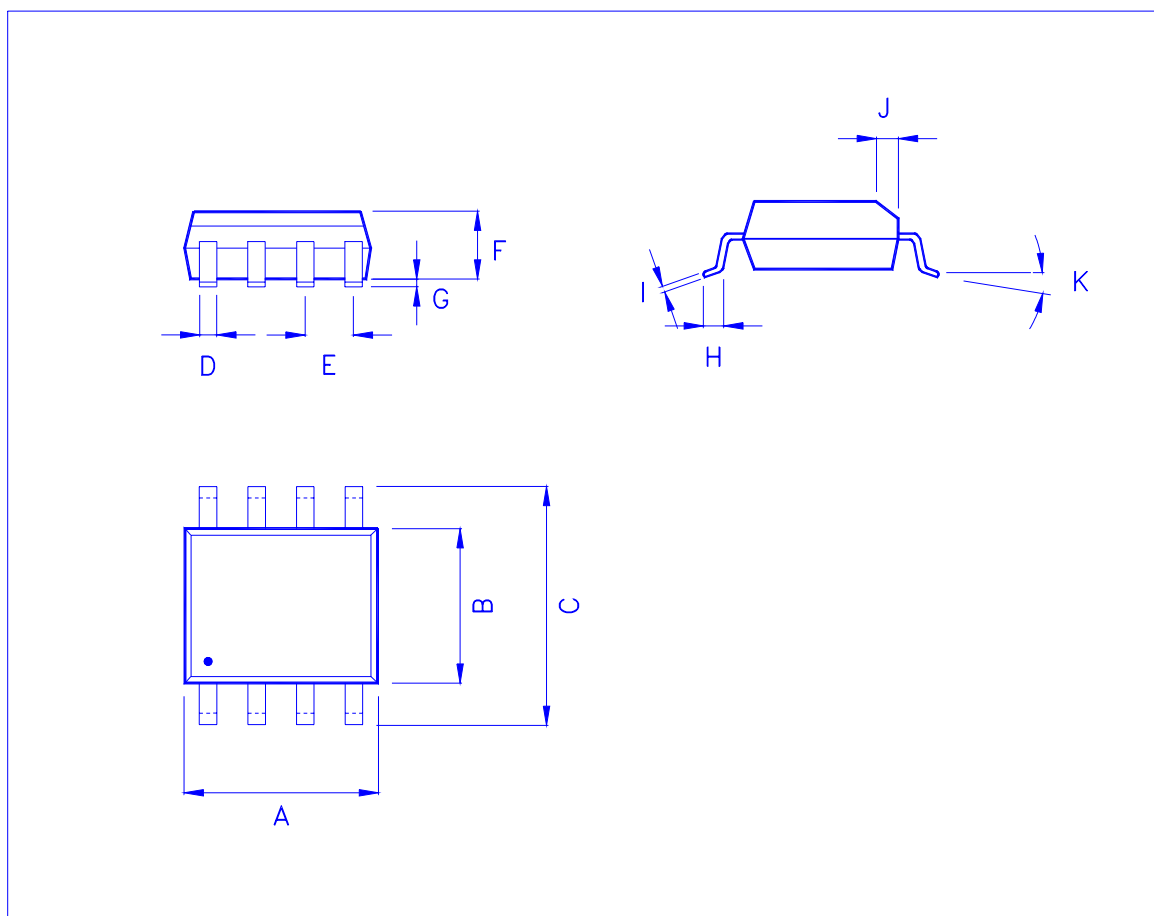

DEMO BOARD DESCRIPTION

The Schematic 3 presents a demo board for the N3856V , This board replaces the output rectifier diode with synchronous rectification MOSFET in flyback power supply and includes all the components needs by the N3856V to operate, R3 and C1 can be adjusted for different switching frequency and turn-on duty demand

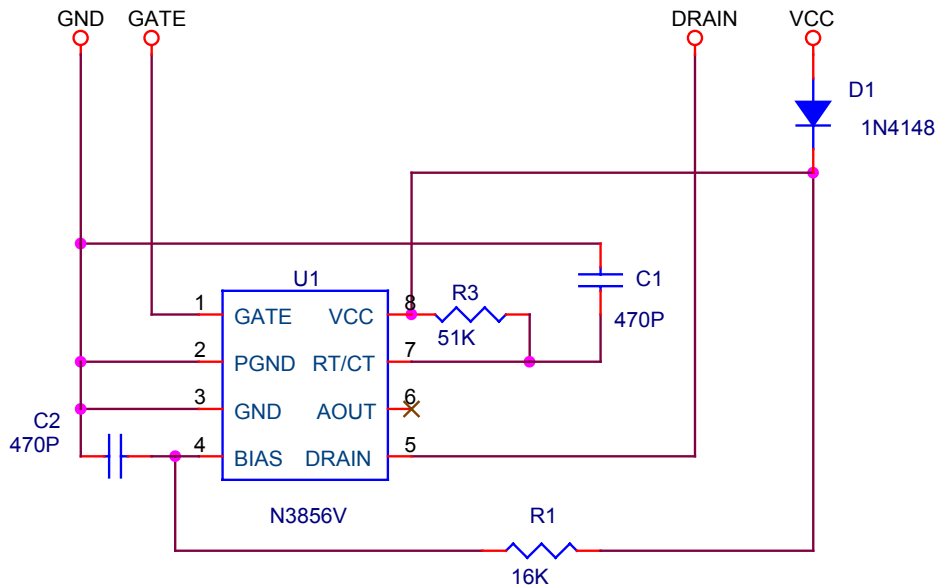

pic.4 demo board layout----componects

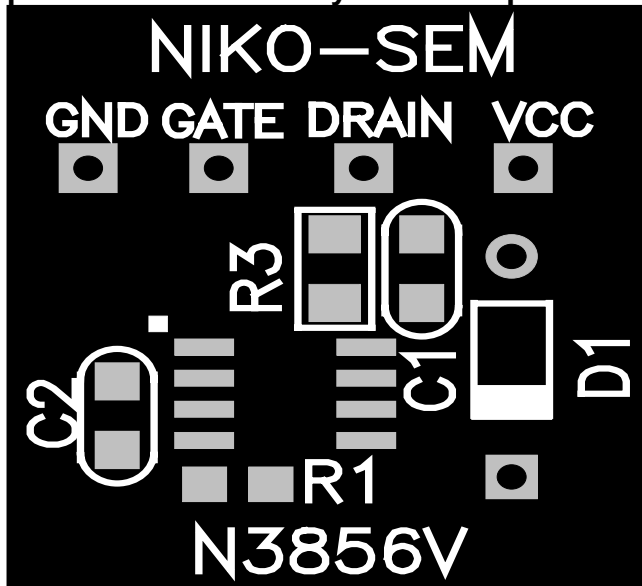

pic.5 demo board layout----soldering side

