

**GENERAL DESCRIPTION**

The N3862 is the low cost integrated PWM primary switcher , it combines a current mode PWM controller with a high voltage power MOSFET, specifically designed for use in the low power output , any universal and single input AC / DC converters, DC / DC converters, battery chargers, AC adapters or stand-by switching power supplies.

The N3861 features a burst mode function at light load condition, when output power works at light load and the duty of gate driver is under 1us, the N3860 will enter the burst mode condition to reduce operating frequency , this special function helps decrease power consumption to be Green Mode Requirement .

The N3862 is capable of powers to 18W maximum for a universal line input.

**FEATURES**

- Low Start-up Current
- Low Operating Supply Current
- Current Mode Control
- 10V~30V Range For VCC Voltage
- Fixed 50KHz Operating Frequency
- Over Power & Short Circuit Protection
- Pulse Output For Driving MOSFET
- Green Mode Requirement
- Burst Mode at Light Load Condition
- Bult-in Power MOSFET
- Bult-in Resistor of Gate Connection
- Very Low Cost Solution
- DIP-8 package

**BLOCK DIAGRAM**

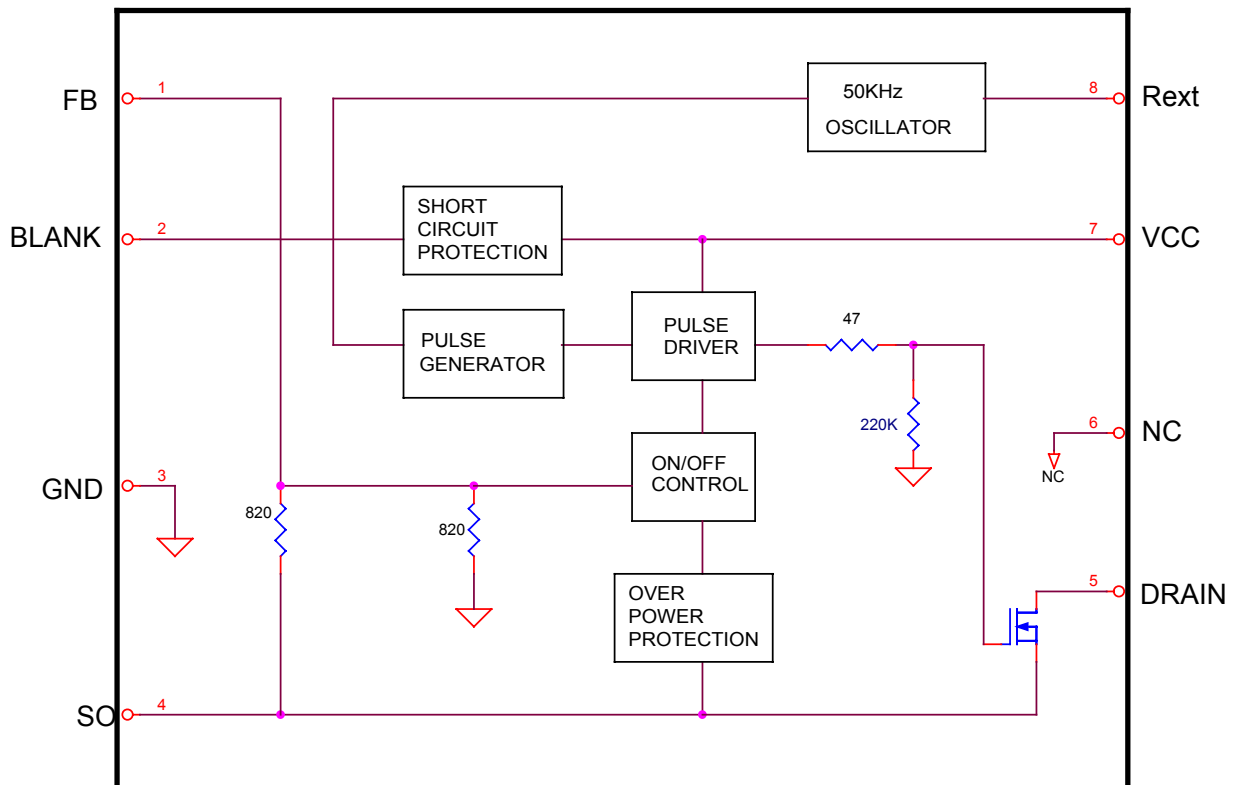

**ABSOLUTE MAXIMUM RATINGS**

	SYMBOL	LIMITS	UNITS
Power supply voltage	Vcc	30	V
Switching Drain-Source Voltage	VDS	-0.3 to 600	V
Continuous Drain Current	ID	2	A
Source to GND Voltage	Vsource	-0.3 to 5	V
Power Dissipation at Ta =50 , SOP / DIP	PTOT	1000 /1200	mW
Junction Temperature	Tj	- 25~ 150	
Storage Temperature	TSTG	- 55 ~ 150	
Lead Temperture(Solding) 10S	TLEAD	300	

**THERMAL DATA**

PARAMETER	SYMBOL	DIP-8	UNIT
Thermal Resistance Junction to Ambient	$\theta_{ja}$	53	/W
Thermal Resistance Junction to Case	$\theta_{jc}$	23	/W

**ELECTRICAL SPECIFICATIONS**

(Vcc =15V ,Ta = - 25 to 125 ;unless otherwise specified)

PARAMETER	SYMBOL	CONDITIONS	MIN	TYP	MAX	UNITS
<b>SUPPLY VOLTAGE SECTION</b>						
Operating Voltage Range	Vcc		10	15	30	V
Operating Supply Current	Icc			1.4		mA
Turn-off threshold	Vcc(th)	Ta = 25	9	9.5	10	V
<b>OSCILLATOR SECTION</b>						
Frequency Range	fs		45	50	55	KHz
<b>POWER SECTION</b>						
Drain-Source Voltage	BVDSS	ID =1mA	600			V
Off State Drain Current	IDSS	VDS=600V, Tj=25 VDS=600V, Tj=125			0.1 0.3	mA
Drain-Source On State Resistance	RDS(ON)	Tj=25 ,ID=2A,	-	-	4	$\Omega$
Drain Capacitance		VDS=25V		56		pF
Rise Time	tr			300		nS
Fall Time	tf			300		nS
Max.Current Sense Voltage	Vcs(max)			1.3		V
Minimum Turn On Time	Tonmin			1		$\mu$ S

**TYPICAL APPLICATION**

**N3862P---- OUTPUT<18W**

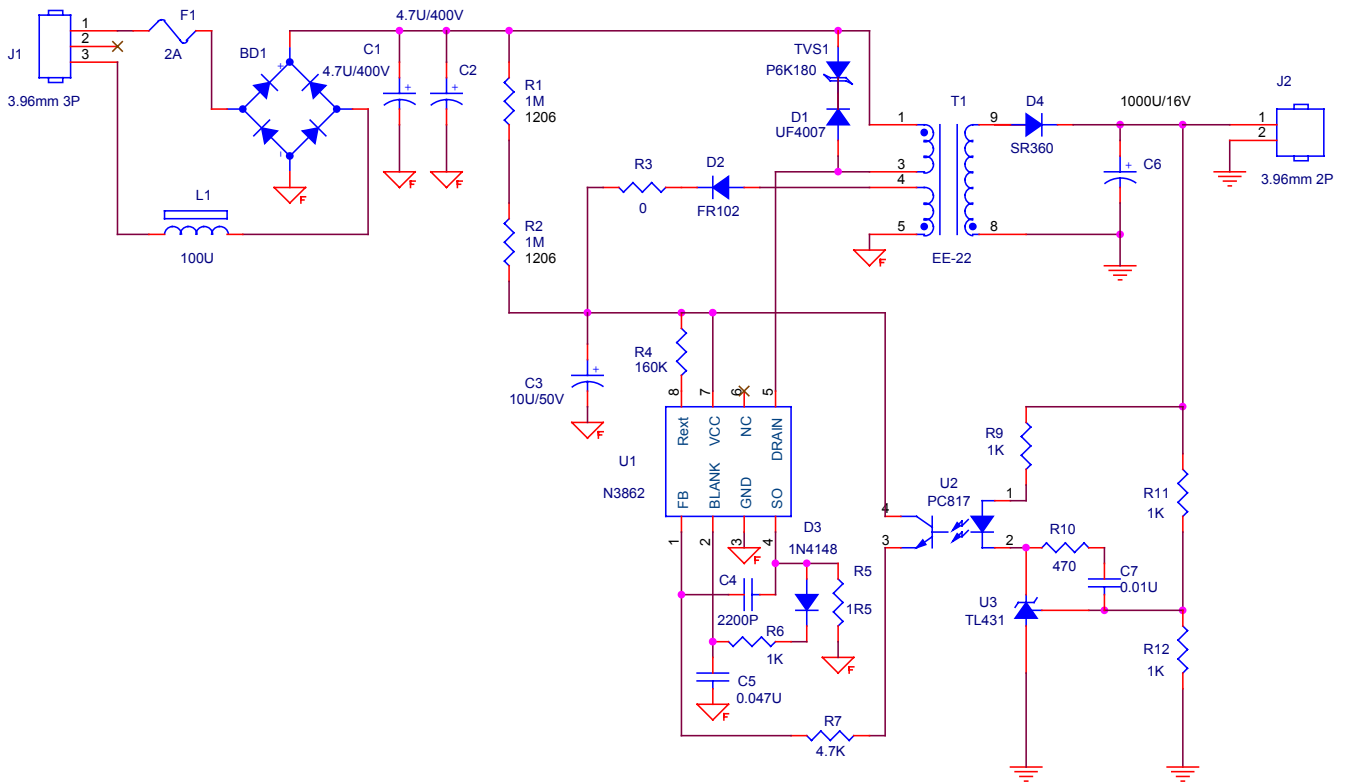

The maximum peak switch current is :

$$I_{PK} = 1.3 / R_s$$

**DEVICE SELECTION GUIDE**

SnPb	Pb Free
N3862P	N3862PG

**PIN CONFIGURATION**

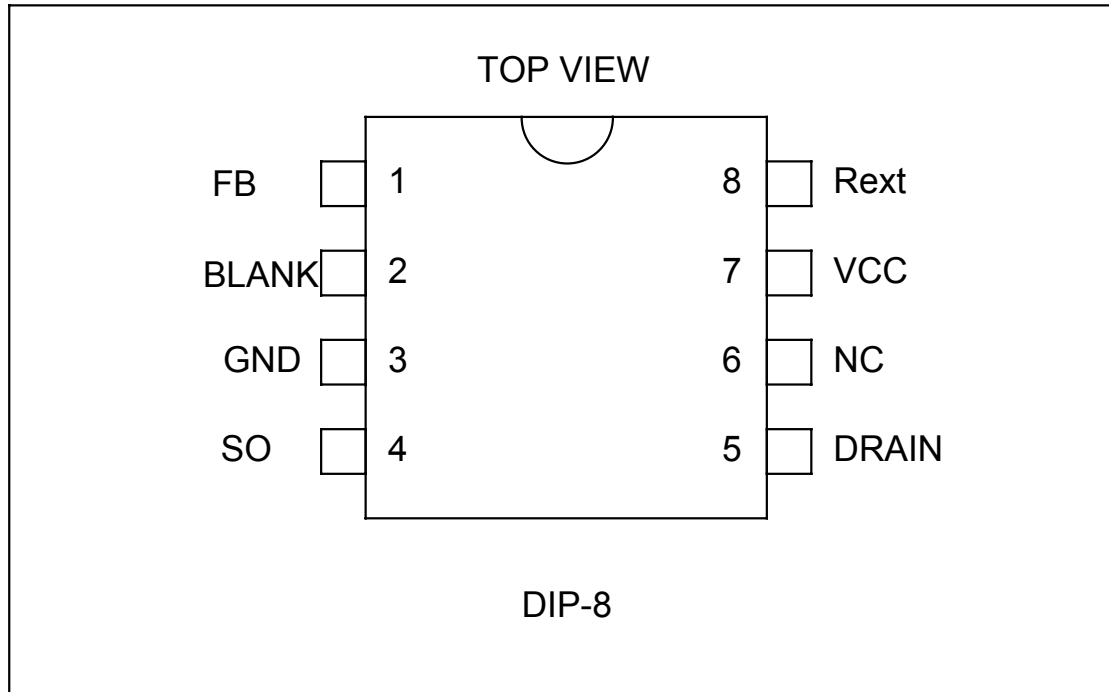

**PIN FUNCTIONS**

NO	FUNCTION	DESCRIPTION
1	FB	Voltage feedback input .
2	BLANK	Set the blanking time to blank the OPP operation when power turn on.
3	GND	Ground , Current return for both the signal and drive circuit .
4	SO	Source of the internal power MOSFET.
5	DRAIN	Drain of the internal power MOSFET.
6	NC	Not connect.
7	VCC	Supply Voltage of this IC .
8	Rext	External resistor,connects 160KΩ resistor to VCC pin(recommend for 1%).

**SOP-8 (D) MECHANICAL DATA**

Dimension	mm			Dimension	mm		
	Min.	Typ.	Max.		Min.	Typ.	Max.
A	4.8	4.9	5.0	H	0.5	0.715	0.83
B	3.8	3.9	4.0	I	0.18	0.254	0.25
C	5.8	6.0	6.2	J		0.22	
D	0.38	0.445	0.51	K	0°	4°	8°
E		1.27		L			
F	1.35	1.55	1.75	M			
G	0.1	0.175	0.25	N			

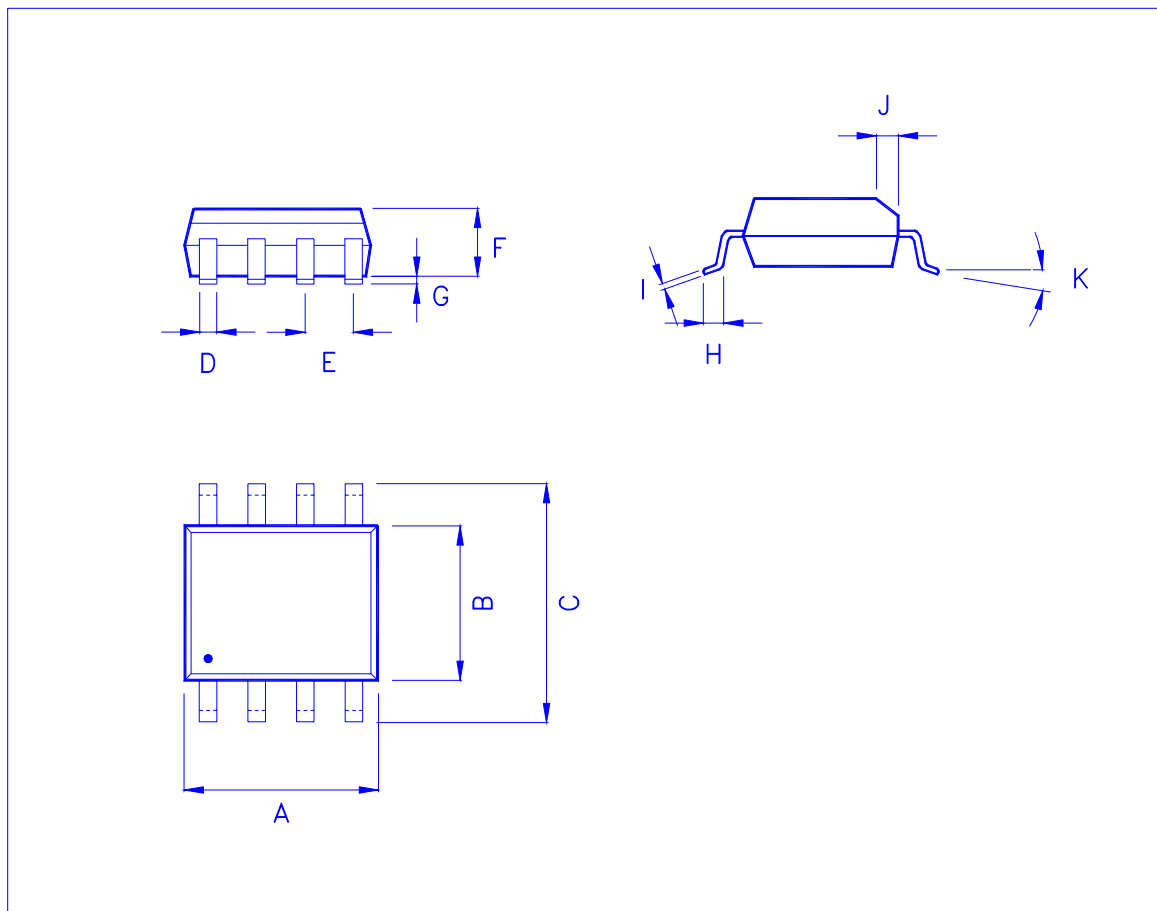

**DIP-8 MECHANICAL DATA**

Dimension	mm			Dimension	mm		
	Min.	Typ.	Max.		Min.	Typ.	Max.
A	8.8		9.6	H	7.95		9.75
B	6.2		7.0	I			
C	0.35	0.45	0.55	J			
D		2.54		K			
E	0.5		0.8	L			
F	3.05	3.28	3.56	M			
G	7.48	7.62	8.13	N			

