



High Efficiency Synchronous Step-Up DC/DC Converter

FEATURES

- High Efficiency 93% ($V_{IN}=2.4V$, $V_{OUT}=3.3V$, $I_{OUT}=200mA$).
- Output Current up to 500mA. (AIC1620 at $V_{IN}=2.4V$ and $V_{OUT}=3.3V$)
- 20 μA Quiescent Supply Current.
- Power-Saving Shutdown Mode (0.1 μA typical).
- Internal Synchronous Rectifier (no external diode)
- On-Chip Low Battery Detector.
- Low Battery Hysteresis.
- Space-Saving Package: MSOP-8

APPLICATIONS

- Palmtop & Notebook Computers.
- PDAs
- Wireless Phones
- Pocket Organizers.
- Digital Cameras.
- Hand-Held Devices with 1 to 2-Cell of NiMH/NiCd Batteries.

DESCRIPTION

The AIC1620/AIC1621 are high efficiency step up DC-DC converter. The start-up voltage is as low as 0.8V and operate with an input voltage down to 0.7V. Consuming only 20 μA of quiescent current. These devices offer a built-in synchronous rectifier that reduces size and cost by eliminating the need for an external Schottky diode and improves overall efficiency by minimizing losses.

The switching frequency depends on the load and the input voltage can range up to 500KHz. The output voltage can be easily set by two external resistors from 1.8V to 4.0V, connecting FB to OUT to get 3.3V. The peak current of the internal switch is fixed at 0.8A (AIC1620), at 0.45A (AIC1621) for design flexibility.

TYPICAL APPLICATION CIRCUIT

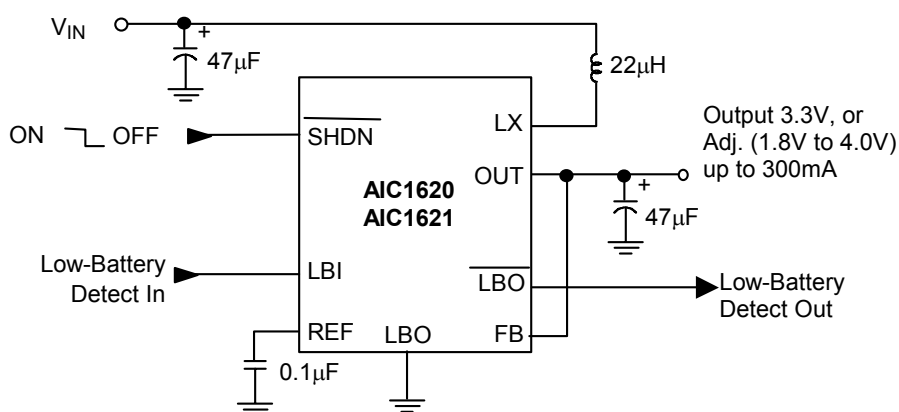



ORDERING INFORMATION

AIC1620XX XX
 AIC1621XX XX

PACKING TYPE
 TR: TAPE & REEL

PACKAGING TYPE
 O: MSOP8 (for AIC1620/21)

C: Commercial
 P: Lead Free Commercial

Example: AIC1620COTR
 → In MSOP8 Package & Taping & Reel Packing Type
 AIC1620POTR
 → In MSOP8 Lead Free Package & Taping & Reel Packing Type

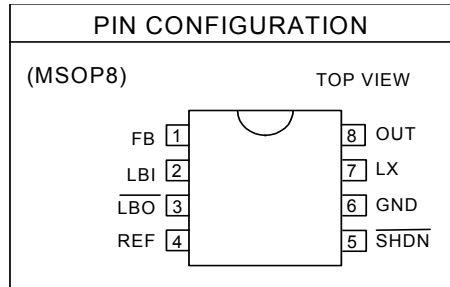

ABSOLUTE MAXIMUM RATINGS

Supply Voltage (OUT to GND).....	8.0V
Switch Voltage (LX to GND).....	$V_{OUT} + 0.3V$
SHDN, LBO to GND.....	6.0V
LBI, REF, FB, to GND.....	$V_{OUT} + 0.3V$
Switch Current (LX).....	-1.5A to +1.5A
Output Current (OUT).....	-1.5A to +1.5A
Operating Temperature Range.....	-40°C ~ +85°C
Maximum Junction Temperature.....	125°C
Storage Temperature Range.....	-65°C ~ 150°C
Lead Temperature (Soldering 10 Sec.).....	260°C

Absolute Maximum Ratings are those values beyond which the life of a device may be impaired.

TEST CIRCUIT

Refer to Typical Application Circuit.



ELECTRICAL CHARACTERISTICS ($V_{IN}=2.0V$, $V_{OUT}=3.3V$ (FB=OUT), $R_L=\infty$, $T_A=25^\circ C$, unless otherwise specified.) (Note1)

PARAMETER	TEST CONDITIONS	MIN.	TYP.	MAX.	UNIT
Minimum Input Voltage			0.7		V
Operating Voltage		1.1		4.0	V
Start-Up Voltage	$R_L=3K\Omega$ (Note2)		0.8	1.1	V
Start-Up Voltage Tempco			-2		mV/°C
Output Voltage Range		1.8		4.0	
Output Voltage	FB = V_{OUT}	3.17	3.3	3.43	V
Steady State Output Current (Note 3)	FB=OUT $(V_{OUT}=3.3V)$	AIC1620	300	400	mA
		AIC1621	150	220	
Reference Voltage	$I_{REF}=0$	1.199	1.23	1.261	V
Reference Voltage Tempco			0.024		mV/°C
Reference Load Regulation	$I_{REF}=0$ to 100 μA		10	30	mV
Reference Line Regulation	$V_{OUT}=1.8V$ to 4V		5	10	mV/V
FB , LBI Input Threshold		1.199	1.23	1.261	V
Internal switch On-Resistance	$I_{LX}=100mA$		0.3		Ω
LX Switch Current Limit	AIC1620	0.6	0.8	1.0	A
	AIC1621	0.3	0.45	0.6	
LX Leakage Current	$V_{LX}=0V, 4V$; $V_{OUT}=4V$		0.05	1	μA
Operating Current into OUT (Note 4)	$V_{FB}=1.4V$, $V_{OUT}=3.3V$		20	35	μA
Shutdown Current into OUT	SHDN = GND		0.1	1	μA
Efficiency	$V_{OUT}=3.3V$, $I_{LOAD}=200mA$		90		%
	$V_{OUT}=2V$, $I_{LOAD}=1mA$		85		
LX Switch On-Time	$V_{FB}=1V$, $V_{OUT}=3.3V$	2	4	7	μS
LX Switch Off-Time	$V_{FB}=1V$, $V_{OUT}=3.3V$	0.6	0.9	1.3	μS
FB Input Current	$V_{FB}=1.4V$		0.03	50	nA



ELECTRICAL CHARACTERISTICS (Continued)

PARAMETER	TEST CONDITIONS	MIN.	TYP.	MAX.	UNIT
LBI Input Current	$V_{LBI} = 1.4V$		1	50	nA
\overline{SHDN} Input Current	$V_{\overline{SHDN}} = 0$ or V_{OUT}		0.07	50	nA
\overline{LBO} Low Output Voltage	$V_{LBI} = 0, I_{SINK} = 1mA$		0.2	0.4	μA
\overline{LBO} Off Leakage Current	$V_{\overline{LBO}} = 5.5V, V_{LBI} = 5.5V$		0.07	1	
LBI Hysteresis			50		mV
\overline{SHDN} Input Voltage	V_{IL}			0.2 V_{OUT}	V
	V_{IH}	0.8 V_{OUT}			

Note 1: Specifications are production tested at $T_A=25^\circ C$. Specifications over the $-40^\circ C$ to $85^\circ C$ operating temperature range are assured by design, characterization and correlation with Statistical Quality Controls (SQC).

Note 2: Start-up voltage operation is guaranteed without the addition of an external Schottky diode between the input and output.

Note 3: Steady-state output current indicates that the device maintains output voltage regulation under load.

Note 4: Device is bootstrapped (power to the IC comes from OUT). This correlates directly with the actual battery supply.

TYPICAL PERFORMANCE CHARACTERISTICS

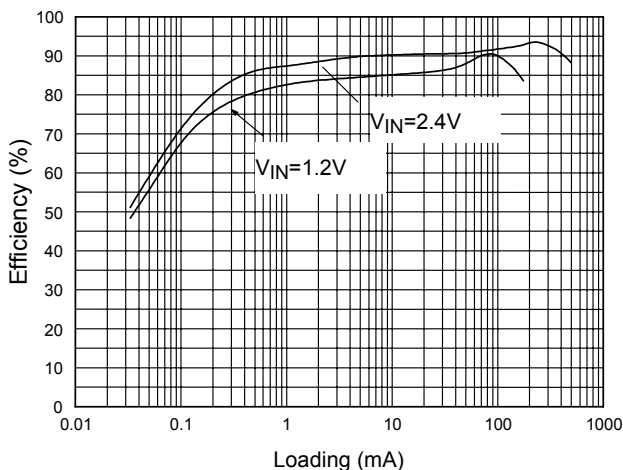

Fig. 1 $V_{OUT}=3.3V$, AIC1620 (0.8A) (ref. to Fig.14)

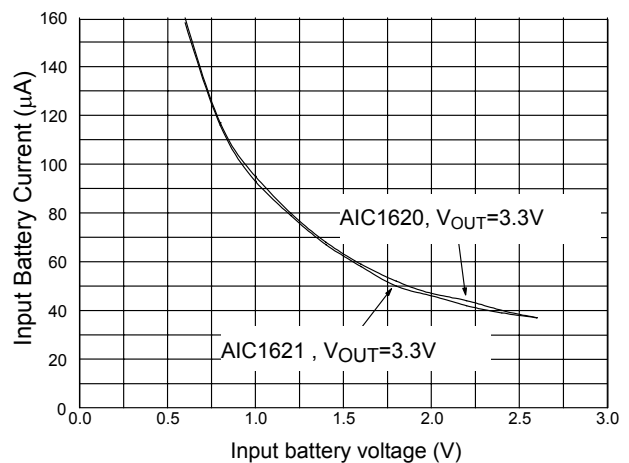

Fig. 2 No-Load Battery Current vs. Input Battery



TYPICAL PERFORMANCE CHARACTERISTICS (Continued)

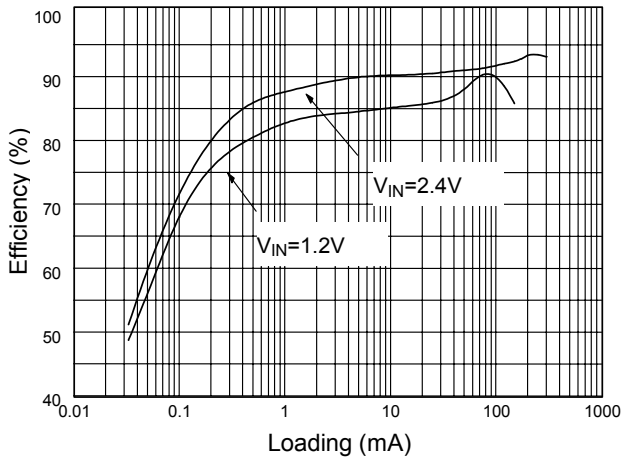

Fig. 3 $V_{OUT}=3.3V$, AIC1621 (0.45A) (ref. to Fig.14)

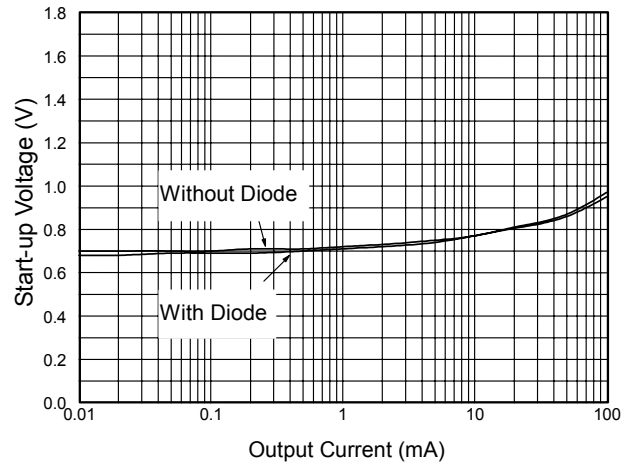

Fig. 4 Start-up Voltage vs. Output Current

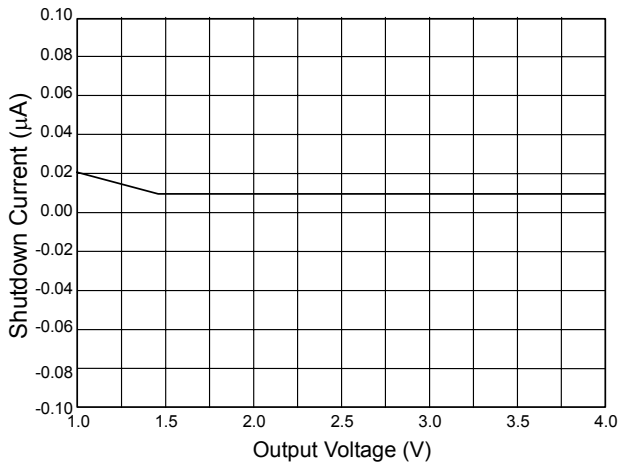

Fig. 5 Shutdown Current vs. Output Voltage

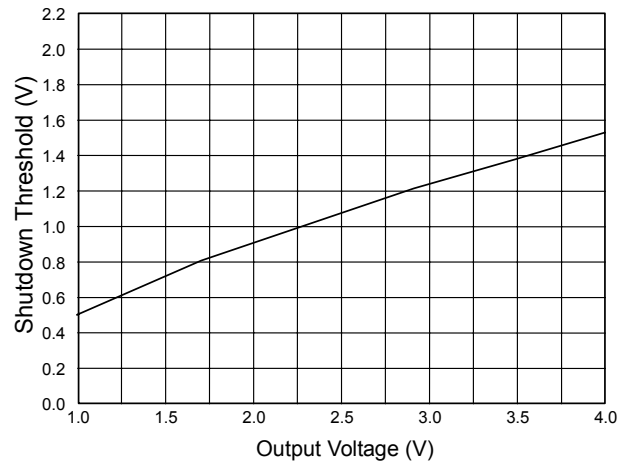

Fig. 6 Shutdown Threshold vs. Output Voltage

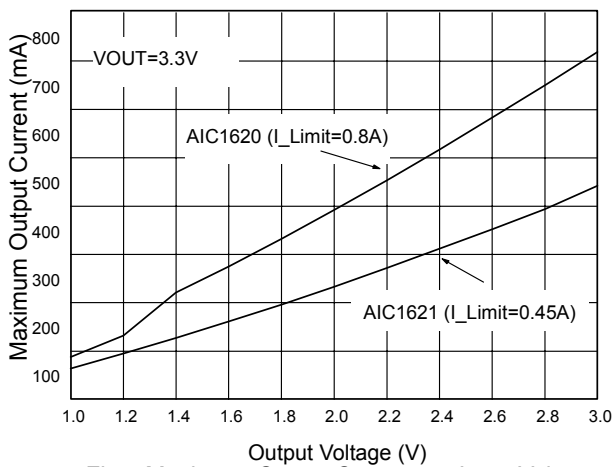

Fig.7 Maximum Output Current vs. Input Voltage

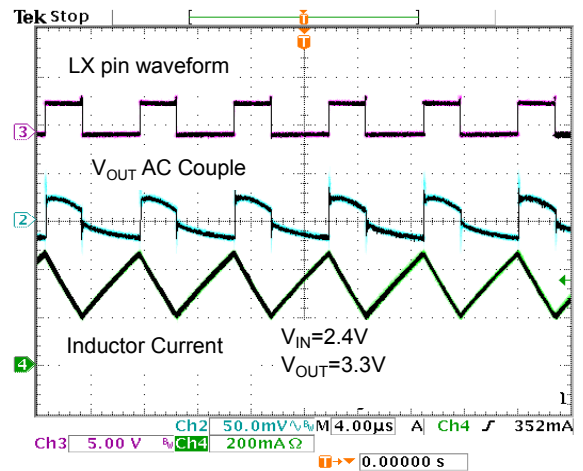

Fig. 8 Heavy Load Waveform



TYPICAL PERFORMANCE CHARACTERISTICS (Continued)

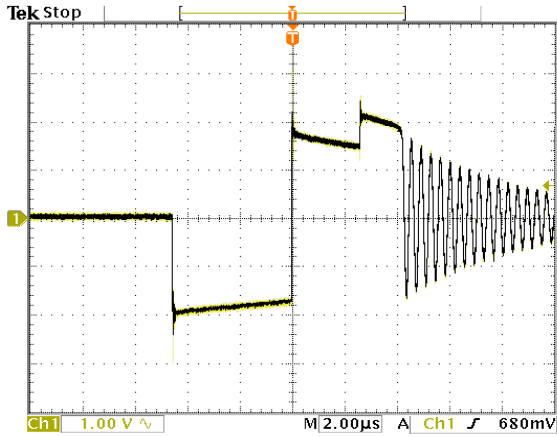

Fig. 9 LX Switching Waveform

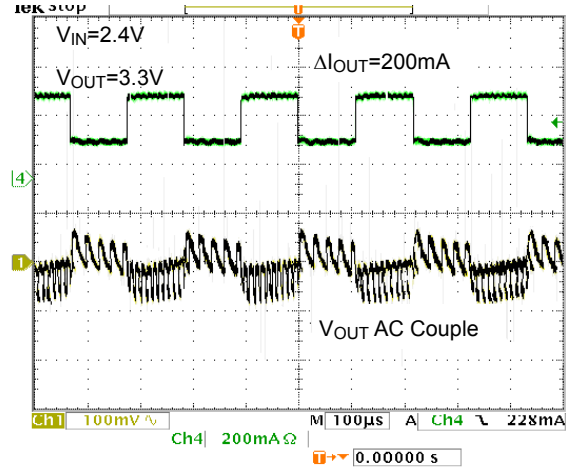
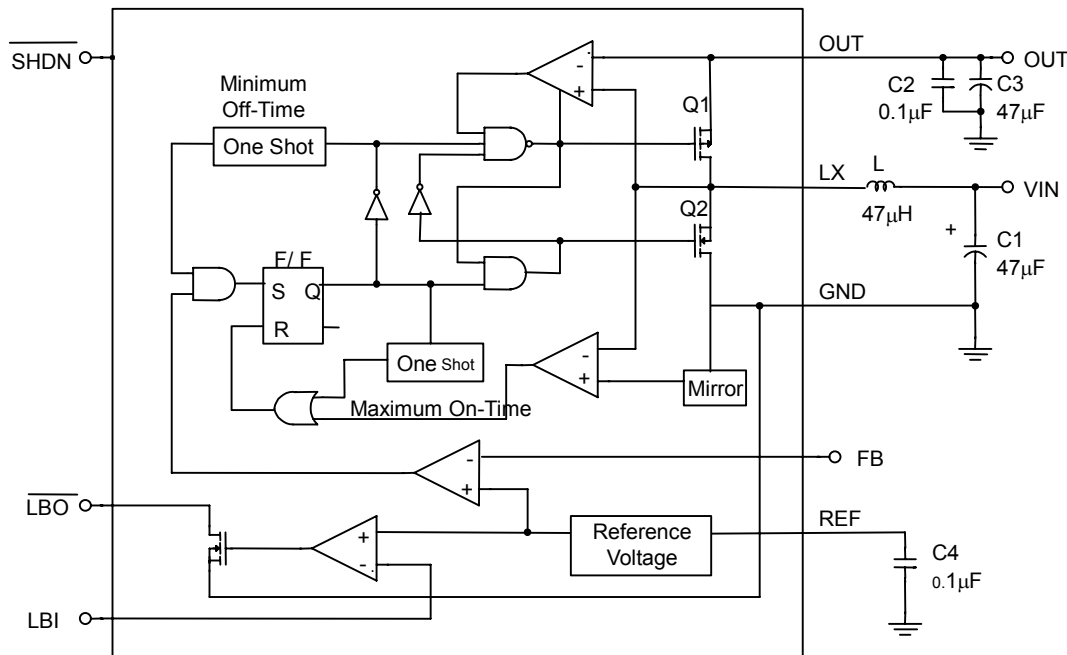

Fig. 10 Load Transient Response

BLOCK DIAGRAM





PIN DESCRIPTIONS

AIC1620/ AIC1621

PIN 1: FB- Connect to OUT for +3.3V output. Use a resistor network to set the output voltage from +1.8V to +4.0V.

PIN 2: LBI- Low-battery comparator input. Internally set to trip at +1.23V.

PIN 3: $\overline{\text{LBO}}$ - Open-drain low battery comparator output. Output is low when V_{LBI} is <1.23V. $\overline{\text{LBO}}$ is high impedance during shutdown.

PIN 4: REF- 1.23V reference voltage. Bypass with a 0.1 μ F capacitor.

PIN 5: $\overline{\text{SHDN}}$ - Shutdown input. High=operating, low=shutdown.

PIN 6: GND- Ground

PIN 7: LX- N-channel and P-channel power MOSFET drain.

PIN 8: OUT- Power output. OUT provides bootstrap power to the IC.

APPLICATION INFORMATION

Overview

AIC1620/AIC1621 series are high efficiency, step-up DC-DC converters, designed to feature a built-in synchronous rectifier, which reduces size and cost by eliminating the need for an external Schottky diode. The start-up voltage of AIC1620/AIC1621 is as low as 0.8V and it operates with an input voltage down to 0.7V. Quiescent supply current is only 20 μ A. The internal P-MOSFET on-resistance is typically 0.3 Ω to improve overall efficiency by minimizing AC losses. The output voltage can be easily set by two external resistors from 1.8V to 4.0V, connecting FB to OUT to get 3.3V. The peak current of the internal switch is fixed at 0.8A (AIC1620) or 0.45A (AIC1621) for design flexibility. The current limit of AIC1620 and AIC1621 are 0.8A and 0.45A respectively. The lower current limit allows the use of a physically smaller inductor in space-sensitive applications.

PFM Control Scheme

The key feature of the AIC1620 series is a unique minimum-off-time, constant-on-time, current-limited, pulse-frequency-modulation (PFM) control scheme (see BLOCK DIAGRAM) with the ultra-low quiescent current. The peak current of the internal N-MOSFET power switch can be fixed at 0.8A (AIC1620) or 0.45A (AIC1621). The switch frequency depends on either loading condition or input voltage, and can range up to 500KHz. It is

voltage, and can range up to 500KHz. It is governed by a pair of one-shots that set a minimum off-time (1 μ S) and a maximum on-time (4 μ S).

Synchronous Rectification

Using the internal synchronous rectifier eliminates the need for an external Schottky diode. Therefore, the cost and board space is reduced. During the cycle of off-time, the P-MOSFET turns on and shunts the N-MOSFET. Due to the low turn-on resistance of MOSFET, the synchronous rectifier significantly improves efficiency without the addition of an external component. Thus, the conversion efficiency can be as high as 93%.

Reference Voltage

The reference voltage (REF) is nominally 1.23V for excellent T.C. performance. In addition, REF pin can source up to 100 μ A to external circuit with good load regulation (<10mV). A bypass capacitor of 0.1 μ F is required for proper operation and good performance



Shutdown

The whole circuit is shutdown when $\overline{V_{SHDN}}$ is low. At shutdown mode, the current can flow from battery to output due to body diode of the P-MOSFET. V_{OUT} falls to approximately $V_{IN}-0.6V$ and LX remains high impedance. The capacitance and load at OUT determine the rate at which V_{OUT} decays. Shutdown can be pulled as high as 6V. Regardless of the voltage at OUT.

Selecting the Output Voltage

V_{OUT} can be simply set to 3.3V by connecting FB pin to OUT due to the use of internal resistor divider in the IC (Fig. 14). In order to adjust output voltage, a resistor divider is connected to V_{OUT} , FB, GND (Fig. 15). V_{out} can be calculated by the following equation:

$$R5=R6 [(V_{OUT} / V_{REF}) -1]$$

Where $V_{REF} = 1.23V$ and V_{OUT} may range from 1.8V to 4V. The recommended $R6$ is 240K Ω .

Low-Battery Detection

AIC1620 series contains an on-chip comparator with 50mV internal hysteresis (REF, REF+50mV) for low battery detection. If the voltage at LBI falls below the internal reference voltage. LBO (an open-drain output) sinks current to GND.

Component Selection

1. Inductor Selection

An inductor value of 22 μ H performs well in most applications. The AIC1620 series also work with inductors in the 10 μ H to 47 μ H range. An inductor with higher peak inductor current tends a higher output voltage ripple ($I_{PEAK} \times$ output filter capacitor ESR). The inductor's DC resistance significantly affects efficiency. We can calculate the maximum output current as follows:

$$I_{OUT(MAX)} = \frac{V_{IN}}{V_{OUT}} \left[I_{LIM} - t_{OFF} \left(\frac{V_{OUT} - V_{IN}}{2 \times L} \right) \right] \eta$$

where $I_{OUT(MAX)}$ =maximum output current in amps

V_{IN} =input voltage

L =inductor value in μ H

η =efficiency (typically 0.9)

t_{OFF} =LX switch' off-time in μ S

I_{LIM} =0.45A or 0.8A

2. Capacitor Selection

The output voltage ripple relates with the peak inductor current and the output capacitor ESR. Besides output ripple voltage, the output ripple current also needs to be concerned. The smaller the capacitor ESR is, the higher the ripple current will be. A filter capacitor with low ESR is helpful to the efficiency and steady state output current of AIC1620 series. Therefore NIPPON tantalum capacitor MCM series with 100 μ F/6V is recommended. A smaller capacitor (down to 47 μ F with higher ESR) is acceptable for light loads or in applications that can tolerate higher output ripple.

3. PCB Layout and Grounding

Since AIC1620's switching frequency can range up to 500kHz, it makes AIC1620 become very sensitive. So careful printed circuit layout is important for minimizing ground bounce and noise. IC's OUT pin should be as clear as possible. And the GND pin should be placed close to the ground plane. Keep the IC's GND pin and the ground leads of the input and output filter capacitors less than 0.2in (5mm) apart. In addition, keep all connection to the FB and LX pins as short as possible. In particular, when using external feedback resistors, locate them as close to the FB as possible. To maximize output power and efficiency and minimize output ripple voltage, use a ground plane and solder the IC's



GND directly to the ground plane. Following are the recommended layout diagrams.

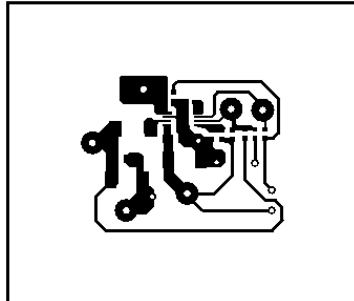

Fig.11 Top layer

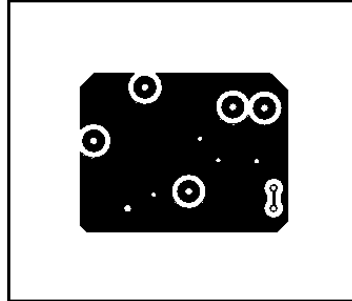

Fig.12 Bottom layer

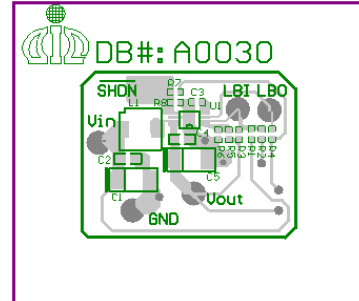
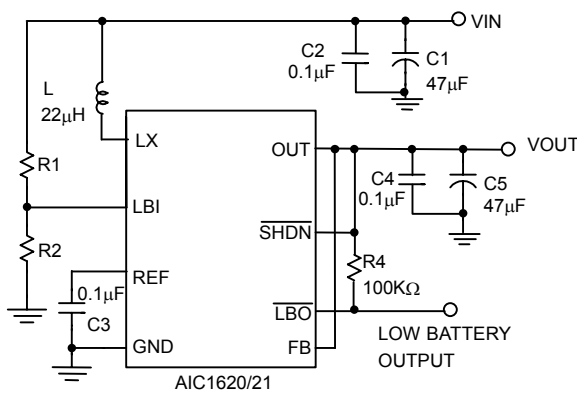

Fig.13 Placement

APPLICATION EXAMPLES



L: TDK SLF7045T-22OMR90
C1, C5: NIPPON Tantalum Capacitor 6MCM476MB2TER

Fig.14 $V_{OUT} = 3.3V$ Application Circuit.

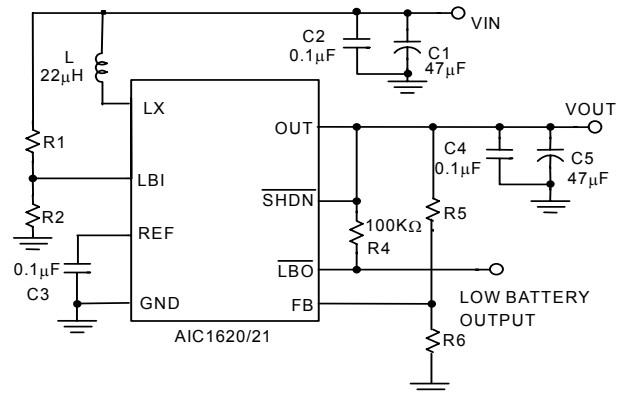

L: TDK SLF7045T-22OMR90
C1, C5: NIPPON Tantalum Capacitor 6MCM476MB2TER
 $V_{OUT} = V_{REF} * (1 + R5/R6)$

Fig.15 An Adjustable Output Application Circuit



■ PHYSICAL DIMENSION (unit: mm)

● 8 LEAD MSOP (CO)(PO)

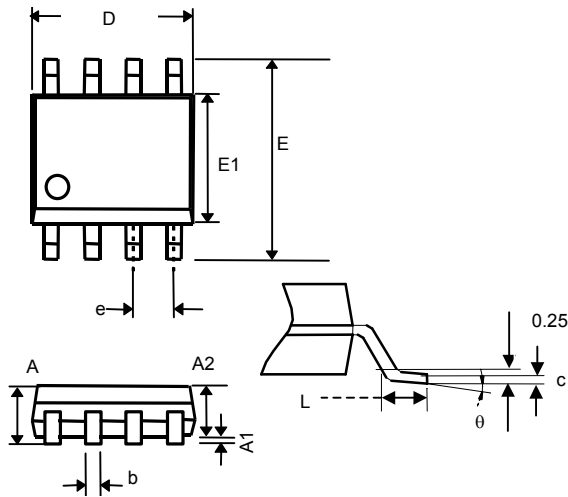

SYMBOL	MIN	MAX
A	-	1.10
A1	0.05	0.15
A2	0.75	0.95
b	0.25	0.40
c	0.13	0.23
D	2.90	3.10
E	4.90 BSC	
E1	2.90	3.10
e	0.65 BSC	
L	0.40	0.70
θ	0°	6°

Note:

Information provided by AIC is believed to be accurate and reliable. However, we cannot assume responsibility for use of any circuitry other than circuitry entirely embodied in an AIC product; nor for any infringement of patents or other rights of third parties that may result from its use. We reserve the right to change the circuitry and specifications without notice.

Life Support Policy: AIC does not authorize any AIC product for use in life support devices and/or systems. Life support devices or systems are devices or systems which, (i) are intended for surgical implant into the body or (ii) support or sustain life, and whose failure to perform, when properly used in accordance with instructions for use provided in the labeling, can be reasonably expected to result in a significant injury to the user.