

UL 60950

ISBN 0-7629-0470-4

Safety of Information Technology Equipment



LISTED BY
UNDERWRITERS LABORATORIES INC.
FOR USE IN THE U.S.



LISTED BY
UNDERWRITERS LABORATORIES INC.
FOR USE IN CANADA



CLASSIFIED BY
UNDERWRITERS LABORATORIES INC.
IN ACCORDANCE WITH
IEC PUBLICATION 60950
FOR USE IN INTERNATIONAL
APPLICATIONS

Underwriters Laboratories Inc. (UL)
333 Pfingsten Road
Northbrook, IL 60062-2096

UL Standard for Safety for Information Technology Equipment, UL 60950

Third Edition, Dated December 1, 2000

Announcement Bulletin(s): This Standard contains the announcement bulletin(s) dated July 23, 1999. The announcement bulletin is located at the end of the Standard.

As indicated on the title page (page 1), this UL Standard for Safety is an American National Standard. Attention is directed to the note on the back side of the title page (page 2) of this Standard outlining the procedures to be followed to retain the approved text of this ANSI/UL Standard.

As indicated on the back side of the title page (page 2), this UL Standard for Safety has been adopted by the Department of Defense.

The master for this Standard at UL's Northbrook Office is the official document insofar as it relates to a UL service and the compliance of a product with respect to the requirements for that product and service, or if there are questions regarding the accuracy of this Standard.

UL's Standards for Safety are copyrighted by UL. Neither a printed copy of a Standard, nor the distribution diskette for a Standard-on-Diskette and the file for the Standard on the distribution diskette should be altered in any way. All of UL's Standards and all copyrights, ownerships, and rights regarding those Standards shall remain the sole and exclusive property of UL.

All rights reserved. No part of this publication may be reproduced, stored in a retrieval system, or transmitted in any form by any means, electronic, mechanical photocopying, recording, or otherwise without prior permission of UL.

Revisions of UL Standards for Safety are issued from time to time. A UL Standard for Safety is current only if it incorporates the most recently adopted revisions.

UL provides this Standard "as is" without warranty of any kind, either expressed or implied, including but not limited to, the implied warranties of merchantability or fitness for any purpose.

In no event will UL be liable for any special, incidental, consequential, indirect or similar damages, including loss of profits, lost savings, loss of data, or any other damages arising out of the use of or the inability to use this Standard, even if UL or an authorized UL representative has been advised of the possibility of such damage. In no event shall UL's liability for any damage ever exceed the price paid for this Standard, regardless of the form of the claim.

UL will attempt to answer support requests concerning electronic versions of its Standards. However, this support service is offered on a reasonable efforts basis only, and UL may not be able to resolve every support request. UL supports the electronic versions of its Standards only if they are used under the conditions and operating systems for which it is intended. UL's support policies may change from time-to-time without notification.

UL reserves the right to change the format, presentation, file types and formats, delivery methods and formats, and the like of both its printed and electronic Standards without prior notice.

Purchasers of the electronic versions of UL's Standards for Safety agree to defend, indemnify, and hold UL harmless from and against any loss, expense, liability, damage, claim, or judgement (including reasonable attorney's fees) resulting from any error or deviation introduced while purchaser is storing an electronic Standard on the purchaser's computer system.

If a single-user version electronic Standard was purchased, one copy of this Standard may be stored on the hard disk of a single personal computer, or on a single LAN file-server or the permanent storage device of a multiple-user computer in such a manner that this Standard may only be accessed by one user at a time and for which there is no possibility of multiple concurrent access.

If a multiple-user version electronic Standard was purchased, one copy of the Standard may be stored on a single LAN file-server, or on the permanent storage device of a multiple-user computer, or on an Intranet server. The number of concurrent users shall not exceed the number of users authorized.

Electronic Standards are intended for on-line use, such as for viewing the requirements of a Standard, conducting a word search, and the like. Only one copy of the Standard may be printed from each single-user version of an electronic Standard. Only one copy of the Standard may be printed for each authorized user of a multiple-user version of an electronic Standard. Because of differences in the computer/software/printer setup used by UL and those of electronic Standards purchasers, the printed copy obtained by a purchaser may not look exactly like the on-line screen view or the printed Standard.

An employee of an organization purchasing a UL Standard can make a copy of the page or pages being viewed for their own fair and/or practical internal use.

The requirements in this Standard are now in effect, except for those paragraphs, sections, tables, figures, and/or other elements of the Standard having future effective dates as indicated in the note following the affected item. The prior text for requirements that have been revised and that have a future effective date are located after the Standard, and are preceded by a "SUPERSEDED REQUIREMENTS" notice.

New product submittals made prior to a specified future effective date will be judged under all of the requirements in this Standard including those requirements with a specified future effective date, unless the applicant specifically requests that the product be judged under the current requirements. However, if the applicant elects this option, it should be noted that compliance with all the requirements in this Standard will be required as a condition of continued Listing, Recognition, and Follow-Up Services after the effective date, and understanding of this should be signified in writing.

Copyright © 2000 Underwriters Laboratories Inc.

This Standard consists of pages dated as shown in the following checklist:

Page	Date
1-430	December 1, 2000

CSA International
CAN/CSA-C22.2 No. 60950-00
Third Edition

Underwriters Laboratories Inc.
UL 60950
Third Edition



Safety of Information Technology Equipment

December 1, 2000

This national standard is based on publication IEC 60950, Third Edition (1999).

Approved
by
Standards Council
of Canada



 *American National Standard*
ANSI/UL 60950-2000

Commitment for Amendments

This Standard is issued jointly by CSA International and Underwriters Laboratories Incorporated. Amendments to this Standard will be made only after processing according to the Standards writing procedures by both CSA International and Underwriters Laboratories Incorporated.

Revisions of this Standard will be made by issuing revised or additional pages bearing their date of issue. A UL Standard is current only if it incorporates the most recently adopted revisions, all of which are itemized on the transmittal notice that accompanies the latest set of revised requirements.

Approval of UL 60950 as an American National Standard is maintained using the continuous maintenance process. Comments or proposals for revisions on any part of the Standard may be submitted to UL at any time. Written comments are to be sent to the UL-SC Standards Department, 1655 Scott Blvd., Santa Clara, CA 95050.

The most recent approval of UL 60950 as an American National Standard (ANSI) occurred on October 11, 2000 and covers the Third Edition.

The U.S. Department of Defense (DoD) has adopted UL 1950 on December 21, 1994. The publication of revised pages or a new edition of this Standard will not invalidate the DoD adoption.

ISBN 1-55324-222-X

**Copyright © 2000
CSA International**

All rights reserved. No part of this publication may be reproduced in any form whatsoever without the prior permission of the publisher.

ISBN 0-7629-0470-4

**Copyright © 2000
Underwriters Laboratories Inc.**

CONTENTS

PREFACE	10	DE
FOREWORD (CSA)	13	DE
FOREWORD (UL)	14	DE
FOREWORD	15	
INTRODUCTION	17	
0 Principles of safety	17	
0.1 General principles of safety	17	
0.2 Hazards	18	
0.3 Materials and components	22	
1 General	23	
1.1 Scope	23	
1.2 Definitions	25	
1.3 General requirements	37	
1.4 General conditions for tests	39	
1.5 Components	44	
1.6 Power interface	47	
1.7 Markings and instructions	48	
2 Protection from hazards	56	
2.1 Protection from electric shock and energy hazards	56	
2.2 SELV circuits	64	
2.3 TNV circuits	67	
2.4 Limited current circuits	72	
2.5 Limited power sources	74	
2.6 Provisions for earthing and bonding	76	
2.7 Overcurrent and earth fault protection in primary circuits	85	
2.8 Safety interlocks	88	
2.9 Electrical insulation	91	
2.10 Clearances, creepage distances and distances through insulation	97	
3 Wiring, connections and supply	118	
3.1 General	118	
3.2 Connection to a.c. mains supplies	122	
3.3 Wiring terminals for connection of external conductors	129	
3.4 Disconnection from the a.c. mains supply	133	
3.5 Interconnection of equipment	136	
3.6 <u>Special considerations for equipment connected to a centralized d.c. power system – DC mains voltages</u>	137	D2 D2
4 Physical requirements	138	
4.1 Stability	138	
4.2 Mechanical strength	139	
4.3 Design and construction	144	
4.4 Protection against hazardous moving parts	150	
4.5 Thermal requirements	152	
4.6 Openings in enclosures	155	
4.7 Resistance to fire	164	
5 Electrical requirements and simulated abnormal conditions	172	

5.1 Touch current and protective conductor current	172	
5.2 Electric strength	182	
5.3 Abnormal operating and fault conditions	186	
6 Connection to telecommunication networks	191	
6.1 Protection of telecommunication network service personnel, and users of other equipment connected to the network, from hazards in the equipment	191	
6.2 Protection of equipment users from overvoltages on telecommunication networks	194	
6.3 Protection of the telecommunication wiring system from overheating	198	
6.4 <u>Protection against overvoltage from power line crosses</u>	199	D2
6.5 <u>Acoustic tests</u>	202	D2

Annex A (normative) Tests for resistance to heat and fire

A.1 Flammability test for fire enclosures of movable equipment having a total mass exceeding 18 kg, and of stationary equipment (see 4.7.3.2)	206
A.1.1 Samples	206
A.1.2 Conditioning of samples	206
A.1.3 Mounting of samples	207
A.1.4 Test flame	207
A.1.5 Test procedure	207
A.1.6 Compliance criteria	207
A.2 Flammability test for fire enclosures of movable equipment having a total mass not exceeding 18 kg, and for material and components located inside fire enclosures (see 4.7.3.2 and 4.7.3.4)	207
A.2.1 Samples	207
A.2.2 Conditioning of samples	208
A.2.3 Mounting of samples	208
A.2.4 Test flame	208
A.2.5 Test procedure	208
A.2.6 Compliance criteria	209
A.2.7 Alternative test	209
A.3 High current arcing ignition test (see 4.7.3.2)	209
A.3.1 Samples	209
A.3.2 Test circuit	209
A.3.3 Test electrodes	210
A.3.4 Test procedure	211
A.3.5 Compliance criteria	211
A.4 Hot wire ignition test (see 4.7.3.2)	211
A.4.1 Samples	211
A.4.2 Test circuit	211
A.4.3 Mounting of samples	211
A.4.4 Test procedure	212
A.4.5 Compliance criterion	213
A.5 Hot flaming oil test (see 4.6.2)	213
A.5.1 Mounting of samples	213
A.5.2 Test procedure	213
A.5.3 Compliance criterion	213
A.6 Flammability tests for classifying materials V-0, V-1 or V-2	213
A.6.1 Samples	213
A.6.2 Conditioning of samples	214
A.6.3 Mounting of samples	214

A.6.4	Test procedure	.214
A.6.5	Compliance criteria	.215
A.6.6	Permitted retest	.215
A.7	Flammability test for classifying foamed materials HF-1, HF-2 or HBF	.215
A.7.1	Samples	.215
A.7.2	Conditioning of samples	.216
A.7.3	Test procedure	.216
A.7.4	Compliance criteria	.216
A.7.5	Compliance criteria, HF-2	.217
A.7.6	Compliance criteria, HF-1	.217
A.7.7	Compliance criteria, HBF	.217
A.7.8	Permitted retest, HF-1 or HF-2	.217
A.7.9	Permitted retest, HBF	.218
A.8	Flammability test for classifying materials HB	.218
A.8.1	Samples	.218
A.8.2	Conditioning of samples	.218
A.8.3	Mounting of samples	.218
A.8.4	Test procedure	.219
A.8.5	Compliance criteria	.220
A.8.6	Permitted retest	.220
A.9	Flammability test for classifying materials 5V	.220
A.9.1	Samples	.220
A.9.2	Conditioning of samples	.220
A.9.3	Test flame	.221
A.9.4	Test procedure, test bars	.221
A.9.5	Test procedure, test plaques	.222
A.9.6	Compliance criteria	.223
A.9.7	Permitted retest	.223
A.10	Stress relief conditioning (see 4.2.7)	.223

Annex B (normative) Motor tests under abnormal conditions (see 4.7.2.2 and 5.3.2)

B.1	General requirements	.224
B.2	Test conditions	.224
B.3	Maximum temperatures	.225
B.4	Running overload test	.227
B.5	Locked-rotor overload test	.227
B.6	Running overload test for d.c. motors in secondary circuits	.228
B.7	Locked-rotor overload test for d.c. motors in secondary circuits	.229
B.7.1	Test procedure	.229
B.7.2	Alternative test procedure	.229
B.7.3	Electric strength test	.229
B.8	Test for motors with capacitors	.229
B.9	Test for three-phase motors	.230
B.10	Test for series motors	.230

Annex C (normative) Transformers (see 1.5.4 and 5.3.3)

C.1	Overload test	.231
C.2	Insulation	.233

Annex D (normative) Measuring instruments for touch-current tests (see 5.1.4)

D.1 Measuring instrument235
D.2 Alternative measuring instrument236

Annex E (normative) Temperature rise of a winding (see 1.4.13 and 4.5.1)

Annex F (normative) Measurement of clearances and creepage distances (see 2.10)

Annex G (normative) Alternative method for determining minimum clearances

G.1 Summary of the procedure for determining minimum clearances247
G.2 Determination of mains transient voltage248
G.3 Determination of telecommunication network transient voltage249
G.4 Determination of required withstand voltage249
G.5 Measurement of transient levels250
G.6 Determination of minimum clearances251

Annex H (normative) Ionizing radiation (see 4.3.13)

Annex J (normative) Table of electrochemical potentials (see 2.6.5.6)

Annex K (normative) Thermal controls (see 1.5.3 and 5.3.7)

K.1 Making and breaking capacity257
K.2 Thermostat reliability257
K.3 Thermostat endurance test258
K.4 Temperature limiter endurance258
K.5 Thermal cut-out reliability258
K.6 Stability of operation258

Annex L (normative) Normal load conditions for some types of electrical business equipment (see 1.2.2.1 and 4.5.1)

L.1 Typewriters259
L.2 Adding machines and cash registers259
L.3 Erasers259
L.4 Pencil sharpeners259
L.5 Duplicators and copy machines260
L.6 Motor-operated files260
L.7 Other business equipment260

Annex M (normative) Criteria for telephone ringing and other signals (see 2.3.1) DE

M.1 Introduction261	
M.2 Method A261	
M.3 Method B265	
M.3.1 Ringing signal265	
M.3.2 Tripping device and monitoring voltage266	
M.4 Other telecommunication signals268	D2

Annex N (normative) Impulse test generators (see 2.10.3.4, 6.2.2.1 and G.5)**Annex P (normative) Normative references**

P.1 UL and CSA Component Requirements (mandatory)274	DC
P.2 UL and CSA Component Requirements (alternative)278	DC

Annex Q (Informative) Bibliography**Annex R (Informative) Examples of requirements for quality control programmes**

R.1 Minimum separation distances for unpopulated coated printed boards (see 2.10.6)285
R.2 Reduced clearances (see 2.10.3)287

Annex S (informative) Procedure for impulse testing (see 6.2.2.3)

S.1 Test equipment289
S.2 Test procedure289
S.3 Examples of waveforms during impulse testing289

Annex T (informative) Guidance on protection against ingress of water (see 1.1.2)**Annex U (normative) Insulated winding wires for use without interleaved insulation (see 2.10.5.4)**

U.1 Wire construction294
U.2 Type tests294
U.2.1 Electric strength294
U.2.2 Flexibility and Adherence294
U.2.3 Heat shock295
U.2.4 Retention of electric strength after bending295
U.3 Test during manufacture296
U.3.1 Routine testing296
U.3.2 Sampling tests296

Annex V (normative) A.C. power distribution systems (see 1.6.1)

V.1 Introduction297
V.2 TN power systems298
V.3 TT power systems301
V.4 IT power systems303

Annex W (informative) Summation of touch currents

W.1 Touch current from electronic circuits305
W.1.1 Floating circuits305
W.1.2 Earthed circuits306
W.2 Interconnection of several equipments307
W.2.1 Isolation308
W.2.2 Common return, isolated from earth309
W.2.3 Common return, connected to protective earth309

Annex X (informative) Maximum heating effect in transformer tests (see C.1)

X.1 Determination of maximum input current310
X.2 Overload test procedure311

Annex NAA (normative) Markings and instructions

D2

Annex NAB (normative) Centralized d.c. power systems and special earthing requirements for d.c. powered equipment (see 3.6)

D2

NAB.1 System descriptions326
NAB.2 General requirements328
NAB.3 Special requirements329

Annex NAC (normative) Power line crosses (see 6.4)

D2

NAC.1 Equipment evaluation330
NAC.2 Test conditions331
NAC.3 Test set-up334
NAC.3.1 Equipment334
NAC.3.2 Wiring simulator335
NAC.3.3 Secondary protector simulator335
NAC.4 Compliance336

Annex NAD (informative) Terminology DE

Annex NAE (informative) U. S. and Canadian regulatory requirements D1

INDEX (informative)

PREFACE

DE

This is the common UL and CSA Standard for Safety of Information Technology Equipment. It is the third edition of CSA Standard CAN/CSA-C22.2 No. 60950 and the third edition of UL 60950. This standard is based on IEC 60950, third edition. DE
DE
DE

Previous editions of this Standard were designated CAN/CSA-C22.2 No. 950/UL 1950. This standard CAN/CSA-C22.2 No. 60950/UL 60950, third edition, replaces the previous standard CAN/CSA-C22.2 No. 950/UL 1950, third edition. The standard number and edition number have been aligned to correspond with the equivalent IEC 60950 standard. No first or second edition of CAN/CSA-C22.2 No. 60950/UL 60950 will be published. DE
DE
DE
DE
DE

This common standard was prepared by CSA International and Underwriters Laboratories Inc. and the information technology and telecommunication industries. The efforts and support of the Electro Federation Canada (EFC, formerly EEMAC), the Information Technology Association of Canada (ITAC), the Information Technology Industry Council (ITI, formerly CBEMA), and the Telecommunication Industry Association (TIA) are gratefully acknowledged. DE
DE
DE
DE
DE

This Standard was reviewed by the CSA Subcommittee on Safety of Information Technology Equipment Including Electrical Business Equipment under the jurisdiction of the Technical Committee on Consumer and Commercial Products and the CSA Strategic Resource Group and was approved by the Technical Committee. DE
DE
DE
DE

This Standard has been approved as a National Standard of Canada by the Standards Council of Canada and has been approved by the American National Standards Institute (ANSI) as an American National Standard. DE
DE
DE

Note: Although the intended primary application of this Standard is stated in its Scope, it is important to note that it remains the responsibility of the users of the Standard to judge its suitability for their particular purpose. DE
DE

Level of Harmonization

DE

This standard adopts the IEC text with deviations. This standard is published as an equivalent standard. DE
DE

An equivalent standard is a standard that is substantially the same in technical content, except as follows. Technical deviations are allowed for Codes and Governmental Regulations and those recognized as being in accordance with NAFTA Article 905, for example because of fundamental, climatic, geographical, technological or infrastructural factors, scientific justification or the level of protection that the country considers appropriate. Presentation shall be word for word except for editorial changes. DE
DE
DE
DE
DE
DE

UL Effective Date

DE

New product submittals through April 1, 2003 will be evaluated using all the requirements in this standard, or if requested in writing, evaluated using the requirements in UL 1950, Third Edition. After April 1, 2003 all new product submittals are required to use this standard. DE
DE
DE

Products that were previously certified by Underwriters Laboratories Inc. to requirements in other existing applicable standards, such as UL 114, UL 478, UL 1459 or UL 1950, First or Second Editions, up to April 1, 2000, and UL 1950, Third Edition, up to April 1, 2003, may DE
DE
DE

continue to be certified without further reinvestigation until April 1, 2005, provided no significant changes or revisions are made to such products. Non-significant changes will be evaluated to the original standard. DE
DE
DE

As of April 1, 2005, all products, including those previously certified by UL, must comply with this standard in order to continue to have the UL Mark applied after this date. DE
DE

CSA Effective Date DE

The effective date for CSA International will be announced through CSA Informs or CSA Certification Notice. DE
DE

General DE

Deviations from the text of the International Electrotechnical Commission Publication 60950, Safety of Information Technology Equipment, Copyright 1999, are indicated by the following applicable margin notations: DE
DE
DE

D1 – deviations based on national regulatory requirements which result in equivalent or more stringent requirements than in IEC 60950. DE
DE

D2 – deviations based on other than national regulatory requirements which result in equivalent or more stringent requirements than in IEC 60950. DE
DE

DI – deviations based on IEC final draft international standards (FDIS). DI deviations may be less stringent than, equivalent to, or more stringent than requirements in IEC 60950. DE
DE
DE

DC – deviations based on UL and CSA component requirements. DC deviations may be less stringent than, equivalent to, or more stringent than component requirements in IEC 60950. DE
DE
DE

D3 – deviations based on bi-national requirements which result in less stringent requirements than in IEC 60950. DE
DE

DE – editorial deviations that correct typographical errors in IEC 60950 or revise the terminology, but do not alter the technical intent of the requirements. This is also used for informative statements such as the Preface and Foreword. DE
DE
DE

D1, D2, D3, DI, DC, and DE deviations have been incorporated into the body of the standard. DE
If deviations necessitate the deletion of IEC 60950 text, the IEC 60950 text has been retained DE
but has been ~~lined out~~. Except for tables and figures and annexes, text added as a result of DE
deviations has been underlined. Text added as the Preface and UL and CSA Forewords is not DE
underlined. DE

Several annexes are included at the back of the standard. Pointers to these annexes are DE
provided in the right-hand margin of the body of the standard to direct the user to these DE
informative/normative annexes. The pointer text is provided in ***BOLD ITALICS***. Examples of DE
such pointers are shown here in the right-hand margin. DE **NAA**

The text, figures, and tables of International Electrotechnical Commission Publication 60950, DE
Safety of Information Technology Equipment, Copyright 1999, are used in this standard with the DE
consent of the International Electrotechnical Commission. DE

NAA
P

The International Electrotechnical Commission Foreword and Introduction are not a part of the requirements of this standard but are included for information purposes only.

DE
DE

FOREWORD (CSA)

DE

The Canadian Standards Association, which operates under the name CSA International (CSA), provides certification services for manufacturers who, under license from CSA, wish to use the appropriate registered CSA Marks on certain products of their manufacture to indicate conformity with CSA Standards.

DE
DE
DE
DE

CSA Certification for a number of products is provided in the interest of maintaining agreed-upon standards of quality, performance, interchangeability and/or safety, as appropriate. Where applicable, certification may form the basis for acceptance by inspection authorities responsible for enforcement of regulations. Where feasible, programs will be developed for additional products for which certification is desired by producers, consumers or other interests.

DE
DE
DE
DE
DE

In performing its functions in accordance with its objectives, CSA does not assume or undertake to discharge any responsibility of the manufacturer or any other party. The opinions and findings of the Association represent its professional judgement given with due consideration to the necessary limitations of practical operation and state of the art at the time the Standard is processed.

DE
DE
DE
DE
DE

Products in substantial accord with this Standard but which exhibit a minor difference or a new feature may be deemed to meet the Standard providing the feature or difference is found acceptable utilizing appropriate CSA Certification and Testing Division Operating Procedures. Products which comply with this Standard shall not be certified if they are found to have additional features which are inconsistent with the intent of this Standard. Products shall not be certifiable if they are discovered to contravene applicable laws or regulations.

DE
DE
DE
DE
DE
DE

Testing techniques, test procedures and instrumentation frequently must be prescribed by the CSA Certification and Testing Division in addition to the technical requirements contained in Standards of CSA. In addition to markings specified in the Standard, the CSA Certification and Testing Division may require special cautions, markings and instructions that are not specified by the Standard.

DE
DE
DE
DE
DE

Some tests required by CSA Standards may be inherently hazardous. The Association neither assumes nor accepts any responsibility for any injury or damage that may occur during or as the result of tests, wherever performed, whether performed in whole or in part by the manufacturer or the Association, and whether or not any equipment, facility or personnel for or in connection with the test is furnished by the manufacturer or the Association.

DE
DE
DE
DE
DE

Manufacturers should note that, in the event of the failure of the CSA Certification and Testing Division to resolve an issue arising from the interpretation of requirements, there is an appeal procedure: the complainant should submit the matter, in writing, to the Secretary of the Canadian Standards Association.

DE
DE
DE
DE

If this Standard is to be used in obtaining CSA Certification please remember, when making application for certification, to request all current Amendments, Bulletins, Notices and Technical Information Letters that may be applicable and for which there may be a nominal charge. For such information or for further information concerning CSA Certification please address your inquiry to Applications and Customer Service, CSA International, 178 Rexdale Boulevard, Toronto, Ontario M9W 1R3.

DE
DE
DE
DE
DE
DE

FOREWORD (UL)

DE

A. This Standard contains basic requirements for products covered by Underwriters Laboratories Inc. (UL) under its Follow-Up Service for this category within the limitations given below and in the Scope section of this Standard. These requirements are based upon sound engineering principles, research, records of tests and field experience, and an appreciation of the problems of manufacture, installation, and use derived from consultation with and information obtained from manufacturers, users, inspection authorities, and others having specialized experience. They are subject to revision as further experience and investigation may show is necessary or desirable.

DE
DE
DE
DE
DE
DE
DE
DE

B. The observance of the requirements of this Standard by a manufacturer is one of the conditions of the continued coverage of the manufacturer's product.

DE
DE

C. A product which complies with the text of this Standard will not necessarily be judged to comply with the Standard if, when examined and tested, it is found to have other features which impair the level of safety contemplated by these requirements.

DE
DE
DE

D. A product employing materials or having forms of construction differing from those detailed in the requirements of this Standard may be examined and tested according to the intent of the requirements and, if found to be substantially equivalent, may be judged to comply with the Standard.

DE
DE
DE
DE

E. UL, in performing its functions in accordance with its objectives, does not assume or undertake to discharge any responsibility of the manufacturer or any other party. The opinions and findings of UL represent its professional judgment given with due consideration to the necessary limitations of practical operation and state of the art at the time the Standard is processed. UL shall not be responsible to anyone for the use of or reliance upon this Standard by anyone. UL shall not incur any obligation or liability for damages, including consequential damages, arising out of or in connection with the use, interpretation of, or reliance upon this Standard.

DE
DE
DE
DE
DE
DE
DE
DE

F. Many tests required by the Standards of UL are inherently hazardous and adequate safeguards for personnel and property shall be employed in conducting such tests.

DE
DE

INTERNATIONAL ELECTROTECHNICAL COMMISSION

SAFETY OF INFORMATION TECHNOLOGY EQUIPMENT

FOREWORD

- 1) The IEC (International Electrotechnical Commission) is a worldwide organization for standardization comprising all national electrotechnical committees (IEC National Committees). The object of the IEC is to promote international co-operation on all questions concerning standardization in the electrical and electronic fields. To this end and in addition to other activities, the IEC publishes International Standards. Their preparation is entrusted to technical committees; any IEC National Committee interested in the subject dealt with may participate in this preparatory work. International, governmental and non-governmental organizations liaising with the IEC also participate in this preparation. The IEC collaborates closely with the International Organization for Standardization (ISO) in accordance with conditions determined by agreement between the two organizations.
- 2) The formal decisions or agreements of the IEC on technical matters express, as nearly as possible, an international consensus of opinion on the relevant subjects since each technical committee has representation from all interested National Committees.
- 3) The documents produced have the form of recommendations for international use and are published in the form of standards, technical reports or guides and they are accepted by the National Committees in that sense.
- 4) In order to promote international unification, IEC National Committees undertake to apply IEC International Standards transparently to the maximum extent possible in their national and regional standards. Any divergence between the IEC Standard and the corresponding national or regional standard shall be clearly indicated in the latter.
- 5) The IEC provides no marking procedure to indicate its approval and cannot be rendered responsible for any equipment declared to be in conformity with one of its standards.
- 6) Attention is drawn to the possibility that some of the elements of this International Standard may be the subject of patent rights. The IEC shall not be held responsible for identifying any or all such patent rights.

International Standard IEC 60950 has been prepared by IEC Technical Committee 74: Safety and energy efficiency of IT equipment.

This third edition cancels and replaces the second edition, issued in 1991, and its amendments 1 (1992), 2 (1993), 3 (1995) and 4 (1996) and constitutes a technical revision.

The text of this edition is based on the following documents:

FDIS	Report on voting
74/498/FDIS	74/504/RVD

Full information on the voting for the approval of this standard can be found in the report on voting indicated in the above table.

Annexes A, B, C, D, E, F, G, H, J, K, L, M, N, P, U and V form an integral part of this standard.

Annexes Q, R, S, T, W and X are for information only.

In this standard, the following print types are used:

- Requirements proper and normative annexes: in roman type.
- *Compliance statements and test specifications: in italic type.*
- Notes and other informative matter: in smaller roman type.
- Normative conditions within tables: in smaller roman type.
- Terms that are defined in 1.2: SMALL CAPITALS.

The numbering system in this standard uses a space instead of a comma to indicate thousands and uses a comma instead of a period to indicate a decimal point. For example, 1 000 means 1,000 and 1,01 means 1.01.

DE
DE
DE

INTRODUCTION

0 Principles of safety

The following principles have been adopted by technical committee 74 in the development of this standard.

These principles do not cover performance or functional characteristics of equipment.

Words printed in SMALL CAPITALS are terms that are defined in 1.2 of this standard.

0.1 General principles of safety

It is essential that designers understand the underlying principles of safety requirements in order that they can engineer safe equipment.

These principles are not an alternative to the detailed requirements of this standard, but are intended to provide designers with an appreciation of the basis of these requirements. Where the equipment involves technologies and materials or methods of construction not specifically covered, the design of the equipment should provide a level of safety not less than those described in these principles of safety.

Designers shall take into account not only normal operating conditions of the equipment but also likely fault conditions, consequential faults, foreseeable misuse and external influences such as temperature, altitude, pollution, moisture, overvoltages on the mains and overvoltages on the telecommunication lines.

The following priorities should be observed in determining what design measures to adopt:

- where possible, specify design criteria that will eliminate, reduce or guard against hazards;
- where the above is not practicable because the functioning of the equipment would be impaired, specify the use of protective means independent of the equipment, such as personal protective equipment (which is not specified in this standard);
- where neither of the above measures is practicable, or in addition to those measures, specify the provision of markings and instructions regarding the residual risks.

There are two types of persons whose safety needs to be considered, USERS (OF OPERATORS) and SERVICE PERSONNEL.

USER is the term applied to all persons other than SERVICE PERSONNEL. Requirements for protection should assume that USERS are not trained to identify hazards, but will not intentionally create a hazardous situation. Consequently, the requirements will provide protection for cleaners and casual visitors as well as the assigned USERS. In general, USERS should not have access to hazardous parts, and to this end, such parts should only be in SERVICE ACCESS AREAS or in equipment located in RESTRICTED ACCESS LOCATIONS.

When USERS are admitted to RESTRICTED ACCESS LOCATIONS they shall be suitably instructed.

SERVICE PERSONNEL are expected to use their training and skill to avoid possible injury to themselves and others due to obvious hazards which exist in SERVICE ACCESS AREAS of the equipment or on equipment located in RESTRICTED ACCESS LOCATIONS. However, SERVICE PERSONNEL should be protected against unexpected hazards. This can be done by, for example, locating parts that need to be accessible for servicing away from electrical and mechanical hazards, providing shields to avoid accidental contact with hazardous parts, and providing labels or instructions to warn personnel about any residual risk.

Information about potential hazards can be marked on the equipment or provided with the equipment, depending on the likelihood and severity of injury, or made available for SERVICE PERSONNEL. In general, USERS shall not be exposed to hazards likely to cause injury, and information provided for USERS should primarily aim at avoiding misuse and situations likely to create hazards, such as connection to the wrong power source and replacement of fuses by incorrect types.

MOVABLE EQUIPMENT is considered to present a slightly increased risk of shock, due to possible extra strain on the supply cord leading to rupture of the earthing conductor. With HAND-HELD EQUIPMENT, this risk is increased; wear on the cord is more likely, and further hazards could arise if the units were dropped. TRANSPORTABLE EQUIPMENT introduces a further factor because it can be used and carried in any orientation; if a small metallic object enters an opening in the ENCLOSURE it can move around inside the equipment, possibly creating a hazard.

0.2 Hazards

Application of a safety standard is intended to reduce the likelihood of injury or damage due to the following:

- electric shock;
- energy related hazards;
- fire;
- heat related hazards;
- mechanical hazards;
- radiation;
- chemical hazards.

0.2.1 Electric shock

Electric shock is due to current passing through the human body. The resulting physiological effects depend on the value and duration of the current and the path it takes through the body. The value of the current depends on the applied voltage, the impedance of the source and the impedance of the body. The body impedance depends in turn on the area of contact, moisture in the area of contact and the applied voltage and frequency. Currents of approximately half a milliampere can cause a reaction in persons in good health and may cause injury indirectly due to involuntary reaction. Higher currents can have more direct effects, such as burn or ventricular fibrillation.

Steady state voltages up to 42,4 V peak, or 60 V d.c., are not generally regarded as hazardous under dry conditions for an area of contact equivalent to a human hand. Bare parts which have to be touched or handled should be at earth potential or properly insulated.

Some equipment will be connected to telephone and other external networks. Some TELECOMMUNICATION NETWORKS operate with signals such as voice and ringing superimposed on a steady DC VOLTAGE; the total may exceed the values given above for steady-state voltages. It is common practice for the SERVICE PERSONNEL of telephone companies to handle parts of such circuits bare-handed. This has not caused serious injury, because of the use of cadenced ringing and because there are limited areas of contact with bare conductors normally handled by SERVICE PERSONNEL. However, the area of contact of a part accessible to the USER, and the likelihood of the part being touched, should be further limited (e.g. by the shape and location of the part).

It is normal to provide two levels of protection for USERS to prevent electric shock. Therefore, the operation of equipment under normal conditions and after a single fault, including any consequential faults, should not create a shock hazard. However, provision of additional protective measures, such as protective earthing or SUPPLEMENTARY INSULATION, is not considered a substitute for, or a relief from, properly designed BASIC INSULATION.

Hazards may result from:

Examples of measures to reduce hazards:

Contact with bare parts normally at HAZARDOUS VOLTAGES.

Prevent USER access to parts at HAZARDOUS VOLTAGES by fixed or locked COVERS, SAFETY INTERLOCKS, etc. Discharge accessible capacitors that are at HAZARDOUS VOLTAGES.

Breakdown of insulation between parts normally at HAZARDOUS VOLTAGES and accessible conductive parts.

Provide BASIC INSULATION and connect the accessible conductive parts and circuits to earth so that exposure to the voltage which can develop is limited because overcurrent protection will disconnect the parts having low impedance faults within a specified time; or provide a metal screen connected to protective earth between the parts, or provide DOUBLE OF REINFORCED INSULATION between the parts, so that breakdown to the accessible part is not likely to occur.

Contact with circuits connected to TELECOMMUNICATION NETWORKS which exceed 42,4 V peak or 60 V d.c.

Limit the accessibility and area of contact of such circuits, and separate them from unearthed parts to which access is not limited.

Breakdown of USER-accessible insulation.

Insulation which is accessible to the USER should have adequate mechanical and electrical strength to reduce the likelihood of contact with HAZARDOUS VOLTAGES.

Table Continued on Next Page

Table Continued

Hazards may result from:

TOUCH CURRENT (leakage current) flowing from parts at HAZARDOUS VOLTAGES to accessible parts, or failure of a protective earthing connection. TOUCH CURRENT may include current due to EMC filter components connected between PRIMARY CIRCUITS and accessible parts.

Examples of measures to reduce hazards:

Limit TOUCH CURRENT to a specified value, or provide a high integrity protective earthing connection.

0.2.2 Energy related hazards

Hazards may result from a short circuit between adjacent poles of high current supplies or high capacitance circuits, causing:

- burns;
- arcing;
- ejection of molten metal.

Even circuits whose voltages are safe to touch may be hazardous in this respect.

Examples of measures to reduce such hazards include:

- separation;
- shielding;
- provision of safety interlocks.

0.2.3 Fire

Hazards may result from excessive temperatures either under normal operating conditions or due to overload, component failure, insulation breakdown or loose connections. Fires originating within the equipment should not spread beyond the immediate vicinity of the source of the fire, nor cause damage to the surroundings of the equipment.

Examples of measures to reduce such hazards include:

- providing overcurrent protection;
- using constructional materials having appropriate flammability properties for their purpose;
- selection of parts, components and consumable materials to avoid high temperature which might cause ignition;
- limiting the quantity of combustible materials used;
- shielding or separating combustible materials from likely ignition sources;
- using ENCLOSURES or barriers to limit the spread of fire within the equipment;

- using suitable materials for ENCLOSURES so as to reduce the likelihood of fire spreading from the equipment.

0.2.4 Heat related hazards

Hazards may result from high temperatures under normal operating conditions, causing:

- burns due to contact with hot accessible parts;
- degradation of insulation and of safety-critical components;
- ignition of flammable liquids.

Examples of measures to reduce such hazards include:

- taking steps to avoid high temperature of accessible parts;
- avoiding temperatures above the ignition point of liquids;
- provision of markings to warn USERS where access to hot parts is unavoidable.

0.2.5 Mechanical hazards

Hazards may result from:

- sharp edges and corners;
- moving parts which have the potential to cause injury;
- equipment instability;
- flying particles from imploding cathode ray tubes and exploding high pressure lamps.

Examples of measures to reduce such hazards include:

- rounding of sharp edges and corners;
- guarding;
- provision of SAFETY INTERLOCKS;
- providing sufficient stability to free-standing equipment;
- selecting cathode ray tubes and high pressure lamps that are resistant to implosion and explosion respectively;
- provision of markings to warn USERS where access is unavoidable.

0.2.6 Radiation

Hazards to USERS and to SERVICE PERSONNEL may result from some forms of radiation emitted by equipment. Examples are sonic (acoustic), radio frequency, infra-red, ultraviolet and ionizing radiation, and high intensity visible and coherent light (lasers).

Examples of measures to reduce such hazards include:

- limiting the energy level of potential radiation sources;
- screening radiation sources;
- provision of SAFETY INTERLOCKS;
- provision of markings to warn USERS where exposure to the radiation hazard is unavoidable.

0.2.7 Chemical hazards

Hazards may result from contact with some chemicals or from inhalation of their vapours and fumes.

Examples of measures to reduce such hazards include:

- avoiding the use of constructional and consumable materials likely to cause injury by contact or inhalation during intended and normal conditions of use;
- avoiding conditions likely to cause leakage or vaporization;
- provision of markings to warn USERS about the hazards.

0.3 Materials and components

Materials and components used in the construction of equipment should be so selected and arranged that they can be expected to perform in a reliable manner for the anticipated life of the equipment without creating a hazard, and would not contribute significantly to the development of a serious fire hazard. Components should be selected so that they remain within their manufacturers' ratings under normal operating conditions, and do not create a hazard under fault conditions.

SAFETY OF INFORMATION TECHNOLOGY EQUIPMENT –

1 General

1.1 Scope

1.1.1 Equipment covered by this standard

**NAA
NAE**

This standard is applicable to mains-powered or battery-powered information technology equipment, including electrical business equipment and associated equipment, with a RATED VOLTAGE not exceeding 600 V and designed to be installed in accordance with the Canadian Electrical Code, Part I, CSA C22.1; CSA C22.2 No. 0; and the National Electrical Code, NFPA 70.

D1
D1
D1

The standard is also applicable to equipment, unless otherwise identified by a marking or instructions, designed to be installed in accordance with Article 645 of the National Electrical Code, NFPA 70, and the Standard for the Protection of Electronic Computer Data-Processing Equipment, NFPA 75.

D1
D1
D1
D1

See annex NAE for examples of and references to regulatory requirements that may apply to this equipment.

D1
D1

This standard is also applicable to such information technology equipment designed and intended to be connected directly to a TELECOMMUNICATION NETWORK, regardless of the source of power.

It is also applicable to such information technology equipment designed to use the AC MAINS SUPPLY as a telecommunication transmission medium (see note 4 of clause 6).

This standard specifies requirements intended to reduce risks of fire, electric shock or injury for the OPERATOR and layman who may come into contact with the equipment and, where specifically stated, for SERVICE PERSONNEL.

This standard is intended to reduce such risks with respect to installed equipment, whether it consists of a system of interconnected units or independent units, subject to installing, operating and maintaining the equipment in the manner prescribed by the manufacturer.

Examples of equipment which is in the scope of this standard are:

accounting machines	motor operated files
bookkeeping machines	PABX's
calculators	paper jogging machines
cash registers	paper trimmers (punchers cutting machines, separators)
copying machines	pencil sharpeners
data circuit terminating equipment	personal computers
data preparation equipment	photoprinting equipment
data processing equipment	plotters
data terminal equipment	point of sale terminals including associated electronic scales
dictation equipment	postage machines
document shredding machines	public information terminals
duplicators	staplers
electrically operated drawing machines	telephone answering machines
erasers	telephone sets
facsimile equipment	text processing equipment
key telephone systems	typewriters
magnetic tape handlers	visual display units
mail processing machines	
micrographic office equipment	
modems	
monetary processing machines including automated teller (cash dispensing) machines	

This list is not intended to be comprehensive, and equipment that is not listed is not necessarily excluded from the scope.

Equipment complying with the relevant requirements in this standard is considered suitable for use with process control equipment, automatic test equipment and similar systems requiring information processing facilities. However, this standard does not include requirements for performance or functional characteristics of equipment.

1.1.2 Additional requirements

P T
NAE

Requirements additional to those specified in this standard may be necessary for:

- equipment intended for operation in special environments, for example, extremes of temperature; excessive dust, moisture or vibration; flammable gases; and corrosive or explosive atmospheres;
- electromedical applications with physical connections to the patient;
- equipment intended to be used in vehicles, on board ships or aircraft, in tropical countries, or at altitudes greater than 2 000 m;
- equipment intended for use where ingress of water is possible; for guidance on such requirements and on relevant testing, see annex T.

NOTE – Attention is drawn to the fact that authorities of some countries impose additional requirements.

1.1.3 Exclusions

P
NAE

This standard does not apply to:

- support equipment, such as air conditioning, fire detection or fire extinguishing systems;
- power supply systems, such as motor-generator sets, battery backup systems and transformers, which are not an integral part of the equipment;
- building installation wiring;
- devices requiring no electrical power.

1.2 Definitions

For the purpose of this International Standard the following definitions apply. Where the terms "voltage" and "current" are used they imply the r.m.s. values, unless otherwise specified.

Definitions in alphabetical order of nouns

AREA, OPERATOR ACCESS	1.2.7.1
AREA, SERVICE ACCESS	1.2.7.2
BODY	1.2.7.5
CABLE, INTERCONNECTING	1.2.11.6
CIRCUIT, ELV	1.2.8.5
CIRCUIT, LIMITED CURRENT	1.2.8.7
CIRCUIT, PRIMARY	1.2.8.2
CIRCUIT, SECONDARY	1.2.8.3
CIRCUIT, SELV	1.2.8.6
CIRCUIT, TNV	1.2.8.9
CIRCUIT, TNV-1	1.2.8.10
CIRCUIT, TNV-2	1.2.8.11
CIRCUIT, TNV-3	1.2.8.12
CLEARANCE	1.2.10.1
CONDUCTOR, PROTECTIVE BONDING	1.2.13.11

CONDUCTOR, PROTECTIVE EARTHING	1.2.13.10
CORD, DETACHABLE POWER SUPPLY	1.2.5.4
CORD, NON-DETACHABLE POWER SUPPLY	1.2.5.5
CREEPAGE DISTANCE	1.2.10.2
CURRENT, PROTECTIVE CONDUCTOR	1.2.13.13
CURRENT, RATED	1.2.1.3
CURRENT, TOUCH	1.2.13.12
CUT-OUT, THERMAL	1.2.11.3
CUT-OUT, THERMAL, AUTOMATIC RESET	1.2.11.4
CUT-OUT, THERMAL, MANUAL RESET	1.2.11.5
EARTHING, FUNCTIONAL	1.2.13.9
ENCLOSURE	1.2.6.1
ENCLOSURE, ELECTRICAL	1.2.6.4
ENCLOSURE, FIRE	1.2.6.2
ENCLOSURE, MECHANICAL	1.2.6.3
ENERGY LEVEL, HAZARDOUS	1.2.8.8
EQUIPMENT, CLASS I	1.2.4.1
EQUIPMENT, CLASS II	1.2.4.2
EQUIPMENT, CLASS III	1.2.4.3
EQUIPMENT, DIRECT PLUG-IN	1.2.3.6
EQUIPMENT, FOR BUILDING-IN	1.2.3.5
EQUIPMENT, HAND-HELD	1.2.3.2
EQUIPMENT, MOVABLE	1.2.3.1
EQUIPMENT, PERMANENTLY CONNECTED	1.2.5.3
EQUIPMENT, PLUGGABLE, TYPE A	1.2.5.1
EQUIPMENT, PLUGGABLE, TYPE B	1.2.5.2
EQUIPMENT, STATIONARY	1.2.3.4
EQUIPMENT, TRANSPORTABLE	1.2.3.3
FREQUENCY, RATED	1.2.1.4
INSULATION, BASIC	1.2.9.2
INSULATION, DOUBLE	1.2.9.4
INSULATION, FUNCTIONAL	1.2.9.1
INSULATION, REINFORCED	1.2.9.5
INSULATION, SUPPLEMENTARY	1.2.9.3
INTERLOCK, SAFETY	1.2.7.6
LIMIT, EXPLOSION	1.2.12.10
LIMITER, TEMPERATURE	1.2.11.2
LOAD, NORMAL	1.2.2.1
LOCATION, RESTRICTED ACCESS	1.2.7.3
MATERIALS, FLAMMABILITY CLASSIFICATION	1.2.12.1
MATERIAL, 5V CLASS	1.2.12.5
MATERIAL, HB CLASS	1.2.12.8
MATERIAL, HBF CLASS FOAMED	1.2.12.9
MATERIAL, HF-1 CLASS FOAMED	1.2.12.6
MATERIAL, HF-2 CLASS FOAMED	1.2.12.7
MATERIAL, V-0 CLASS	1.2.12.2
MATERIAL, V-1 CLASS	1.2.12.3
MATERIAL, V-2 CLASS	1.2.12.4
NETWORK, TELECOMMUNICATION	1.2.13.8
OPERATION, CONTINUOUS	1.2.2.3
OPERATION, INTERMITTENT	1.2.2.5
OPERATION, SHORT TIME	1.2.2.4
OPERATOR	1.2.13.7
PART, DECORATIVE	1.2.6.5
PERSONNEL, SERVICE	1.2.13.5
RANGE, RATED FREQUENCY	1.2.1.5
RANGE, RATED VOLTAGE	1.2.1.2

SUPPLY, A.C. MAINS	1.2.8.1
SURFACE, BOUNDING	1.2.10.3
TEST, ROUTINE	1.2.13.3
TEST, SAMPLING	1.2.13.2
TEST, TYPE	1.2.13.1
THERMOSTAT	1.2.11.1
TIME, RATED OPERATING	1.2.2.2
TOOL	1.2.7.4
USER	1.2.13.6
VOLTAGE, DC	1.2.13.4
VOLTAGE, HAZARDOUS	1.2.8.4
VOLTAGE, MAINS TRANSIENT	1.2.9.9
VOLTAGE, PEAK WORKING	1.2.9.7
VOLTAGE, RATED	1.2.1.1
VOLTAGE, REQUIRED WITHSTAND	1.2.9.8
VOLTAGE, TELECOMMUNICATION NETWORK TRANSIENT	1.2.9.10
VOLTAGE, WORKING	1.2.9.6

1.2.1 Equipment electrical ratings

1.2.1.1 RATED VOLTAGE: The supply voltage (for a three-phase AC MAINS SUPPLY, the line-to-line voltage) as declared by the manufacturer.

1.2.1.2 RATED VOLTAGE RANGE: The supply voltage range as declared by the manufacturer, expressed by its lower and upper RATED VOLTAGES.

1.2.1.3 RATED CURRENT: The input current of the equipment as declared by the manufacturer.

1.2.1.4 RATED FREQUENCY: The supply frequency as declared by the manufacturer.

1.2.1.5 RATED FREQUENCY RANGE: The supply frequency range as declared by the manufacturer, expressed by its lower and upper RATED FREQUENCIES.

1.2.2 Operating conditions

1.2.2.1 NORMAL LOAD: The mode of operation which approximates as closely as possible the most severe conditions of normal use in accordance with the operating instructions. However, when the conditions of actual use can obviously be more severe than the maximum recommended load conditions, a load is used that is representative of the maximum that can be applied. **L**

NOTE – NORMAL LOAD conditions for some types of electrical business equipment are given in annex L.

1.2.2.2 RATED OPERATING TIME: The operating time assigned to the equipment by the manufacturer.

1.2.2.3 CONTINUOUS OPERATION: Operation under NORMAL LOAD for an unlimited period.

1.2.2.4 SHORT-TIME OPERATION: Operation under NORMAL LOAD for a specified period, starting from cold, the intervals after each period of operation being sufficient to allow the equipment to cool down to room temperature.

1.2.2.5 INTERMITTENT OPERATION: Operation in a series of specified identical cycles, each composed of a period of operation under NORMAL LOAD followed by a rest period with the equipment switched off or running idle.

1.2.3 Equipment mobility

1.2.3.1 MOVABLE EQUIPMENT: Equipment which is either:

- 18 kg or less in mass and not fixed, or
- equipment with wheels, castors or other means to facilitate movement by the OPERATOR as required to perform its intended use.

NOTE – MOVABLE EQUIPMENT includes wall-mounted equipment whose mounting means permits removal by an OPERATOR.

DE

1.2.3.2 HAND-HELD EQUIPMENT: MOVABLE EQUIPMENT, or a part of any kind of equipment, that is intended to be held in the hand during normal use.

1.2.3.3 TRANSPORTABLE EQUIPMENT: MOVABLE EQUIPMENT that is intended to be routinely carried by a USER.

NOTE – Examples include laptop personal computers, pen-based tablet computers, and their portable accessories such as printers and CD-ROM drives.

1.2.3.4 STATIONARY EQUIPMENT: Equipment that is not MOVABLE EQUIPMENT.

1.2.3.5 EQUIPMENT FOR BUILDING-IN: Equipment intended to be installed in a prepared recess, such as in a wall, or similar situation.

NOTE – In general, EQUIPMENT FOR BUILDING-IN does not have an ENCLOSURE on all sides, as some of the sides will be protected after installation.

1.2.3.6 DIRECT PLUG-IN EQUIPMENT: Equipment that is intended to be used without a power supply cord; the mains plug forms an integral part of the equipment ENCLOSURE so that the weight of the equipment is taken by the socket-outlet.

1.2.4 Classes of equipment – Protection against electric shock

NOTE – Some information technology equipment cannot be identified as conforming to one of the following classes.

1.2.4.1 CLASS I EQUIPMENT: Equipment where protection against electric shock is achieved by:

- using BASIC INSULATION, and also
- providing a means of connecting to the PROTECTIVE EARTHING CONDUCTOR in the building wiring those conductive parts that are otherwise capable of assuming HAZARDOUS VOLTAGES if the BASIC INSULATION fails.

NOTE – CLASS I EQUIPMENT may have parts with DOUBLE INSULATION or REINFORCED INSULATION.

1.2.4.2 CLASS II EQUIPMENT: Equipment in which protection against electric shock does not rely on BASIC INSULATION only, but in which additional safety precautions, such as DOUBLE INSULATION or REINFORCED INSULATION are provided, there being no reliance on either protective earthing or installation conditions.

1.2.4.3 CLASS III EQUIPMENT: Equipment in which protection against electric shock relies upon supply from SELV CIRCUITS and in which HAZARDOUS VOLTAGES are not generated.

NOTE – For CLASS III EQUIPMENT, although there is no requirement for protection against electric shock, all other requirements of the standard apply.

1.2.5 Connection to the supply

P

1.2.5.1 PLUGGABLE EQUIPMENT TYPE A: Equipment which is intended for connection to the building installation wiring via a non-industrial plug and socket-outlet or a non-industrial appliance coupler, or both.

NOTE – 1-15, 2-15, 2-20, 5-15 and 5-20 plugs and outlets as specified in IEC 60083 are considered to be non-industrial within the meaning of this standard.

DE
DE

1.2.5.2 PLUGGABLE EQUIPMENT TYPE B: Equipment which is intended for connection to the building installation wiring via an industrial plug and socket-outlet or an appliance coupler, or both, complying with IEC 60309, or with a comparable national standard.

1.2.5.3 PERMANENTLY CONNECTED EQUIPMENT: Equipment which is intended for connection to the building installation wiring using screw terminals or other reliable means.

1.2.5.4 DETACHABLE POWER SUPPLY CORD: A flexible cord, for supply purposes, intended to be connected to the equipment by means of a suitable appliance coupler.

1.2.5.5 NON-DETACHABLE POWER SUPPLY CORD: A flexible cord, for supply purposes, fixed to or assembled with the equipment.

Such a cord may be:

Ordinary: A flexible cord which can be easily replaced without special preparation of the cord or special TOOLS, or

Special: A flexible cord which is specially prepared or requires the use of specially designed TOOLS for replacement, or is such that it cannot be replaced without damage to the equipment.

The term "specially prepared" includes provision of an integral cord guard, the use of cable lugs, formation of eyelets, etc., but not the re-shaping of the conductor before introduction into a terminal or the twisting of a stranded conductor to consolidate the end.

1.2.6 Enclosures

1.2.6.1 ENCLOSURE: A part of the equipment providing one or more of the functions described in 1.2.6.2, 1.2.6.3, or 1.2.6.4.

NOTE – One type of ENCLOSURE can be inside another type (e.g. an ELECTRICAL ENCLOSURE inside a FIRE ENCLOSURE or a FIRE ENCLOSURE inside an ELECTRICAL ENCLOSURE). Also, a single ENCLOSURE can provide the functions of more than one type (e.g. those of both an ELECTRICAL ENCLOSURE and a FIRE ENCLOSURE).

1.2.6.2 FIRE ENCLOSURE: A part of the equipment intended to minimize the spread of fire or flames from within.

1.2.6.3 MECHANICAL ENCLOSURE: A part of the equipment intended to reduce the risk of injury due to mechanical and other physical hazards.

NAD

1.2.6.4 ELECTRICAL ENCLOSURE: A part of the equipment intended to limit access to parts that may be at HAZARDOUS VOLTAGE OR HAZARDOUS ENERGY LEVELS OR are in TNV CIRCUITS.

1.2.6.5 DECORATIVE PART: A part of the equipment, outside the ENCLOSURE, which has no safety function.

1.2.7 Accessibility

1.2.7.1 OPERATOR ACCESS AREA: An area to which, under normal operating conditions, one of the following applies:

- access can be gained without the use of a TOOL, or
- the means of access is deliberately provided to the OPERATOR, or
- the OPERATOR is instructed to enter regardless of whether or not a TOOL is needed to gain access.

The terms "access" and "accessible", unless qualified, relate to OPERATOR ACCESS AREA as defined above.

1.2.7.2 SERVICE ACCESS AREA: An area, other than an OPERATOR ACCESS AREA, where it is necessary for SERVICE PERSONNEL to have access even with the equipment switched on.

1.2.7.3 RESTRICTED ACCESS LOCATION: A location for equipment where both of the following paragraphs apply:

- access can only be gained by SERVICE PERSONNEL or by USERS who have been instructed about the reasons for the restrictions applied to the location and about any precautions that shall be taken; and

- access is through the use of a TOOL or lock and key, or other means of security, and is controlled by the authority responsible for the location.

NOTE – The requirements for equipment intended for installation in RESTRICTED ACCESS LOCATIONS are the same as for OPERATOR ACCESS AREAS, except as given in 1.7.17, 2.1.3 and 4.5.1 4.4.3.

DE

1.2.7.4 TOOL: A screwdriver or any other object which may be used to operate a screw, latch or similar fixing means.

1.2.7.5 BODY: All accessible conductive parts, shafts of handles, knobs, grips and the like, and metal foil in contact with all accessible surfaces of insulating material.

1.2.7.6 SAFETY INTERLOCK: A means either of preventing access to a hazardous area until the hazard is removed, or of automatically removing the hazardous condition when access is gained.

1.2.8 Circuits and circuit characteristics

P

1.2.8.1 AC MAINS SUPPLY: The external a.c. power distribution system supplying power to the equipment. These power sources include public or private utilities and, unless otherwise specified in the standard (e.g. 1.4.5), equivalent sources such as motor-driven generators and uninterruptible power supplies.

NOTE – See annex V for typical examples of a.c. power distribution systems.

1.2.8.2 PRIMARY CIRCUIT: A circuit which is directly connected to the AC MAINS SUPPLY. It includes, for example, the means for connection to the AC MAINS SUPPLY, the primary windings of transformers, motors and other loading devices.

NOTE – Conductive parts of an INTERCONNECTING CABLE may be part of a PRIMARY CIRCUIT as stated in 1.2.11.6.

1.2.8.3 SECONDARY CIRCUIT: A circuit which has no direct connection to a PRIMARY CIRCUIT and derives its power from a transformer, converter or equivalent isolation device, or from a battery.

NOTE – Conductive parts of an INTERCONNECTING CABLE may be part of a SECONDARY CIRCUIT as stated in 1.2.11.6.

1.2.8.4 HAZARDOUS VOLTAGE: A voltage exceeding 42,4 V peak, or 60 V d.c., existing in a circuit which does not meet the requirements for either a LIMITED CURRENT CIRCUIT or a TNV CIRCUIT.

1.2.8.5 ELV CIRCUIT: A SECONDARY CIRCUIT with voltages between any two conductors of the circuit, and between any one such conductor and earth (see 1.4.9), not exceeding 42,4 V peak, or 60 V d.c., under normal operating conditions, which is separated from HAZARDOUS VOLTAGE by BASIC INSULATION, and which neither meets all of the requirements for an SELV CIRCUIT nor meets all of the requirements for a LIMITED CURRENT CIRCUIT.

1.2.8.6 SELV CIRCUIT: A SECONDARY CIRCUIT which is so designed and protected that under normal operating conditions and single fault conditions, its voltages do not exceed a safe value.

NOTE 1 – The limit values of voltages under normal operating conditions and single fault conditions (see 1.4.14) are specified in 2.2. See also table 1A.

NOTE 2 – This definition of an SELV CIRCUIT differs from the term “SELV system” as used in IEC 61140¹.

1.2.8.7 LIMITED CURRENT CIRCUIT: A circuit which is so designed and protected that, under both normal operating conditions and single fault conditions, the current which can be drawn is not hazardous.

NOTE – The limit values of currents under normal operating conditions and single fault conditions (see 1.4.14) are specified in 2.4.

1.2.8.8 HAZARDOUS ENERGY LEVEL: A stored energy level of 20 J or more, or an available continuous power level of 240 VA or more, at a potential of 2 V or more.

1.2.8.9 TNV CIRCUIT: A circuit which is in the equipment and to which the accessible area of contact is limited and that is so designed and protected that, under normal operating conditions and single fault conditions (see 1.4.14), the voltages do not exceed specified limit values.

A TNV CIRCUIT is considered to be a SECONDARY CIRCUIT in the meaning of this standard.

NOTE 1 – The specified limit values of voltages under normal operating conditions and single fault conditions (see 1.4.14) are given in 2.3.1. Requirements regarding accessibility of TNV CIRCUITS are given in 2.1.1.1.

TNV CIRCUITS are classified as TNV-1, TNV-2 and TNV-3 CIRCUITS as defined in 1.2.8.10, 1.2.8.11, and 1.2.8.12.

NOTE 2 – The voltage relationships between SELV and TNV CIRCUITS are shown in table 1A.

NOTE 3 – Conductive parts of an INTERCONNECTING CABLE may be part of a TNV CIRCUIT as stated in 1.2.11.6.

Table 1A – Voltage ranges of SELV and TNV circuits

Overvoltages from TELECOMMUNICATION NETWORKS possible?	Normal operating voltages	
	Within SELV CIRCUIT limits	Exceeding SELV CIRCUIT limits but within TNV CIRCUIT limits
Yes	TNV-1 CIRCUIT	TNV-3 CIRCUIT
No	SELV CIRCUIT	TNV-2 CIRCUIT

1.2.8.10 TNV-1 CIRCUIT: A TNV CIRCUIT:

- whose normal operating voltages do not exceed the limits for an SELV CIRCUIT under normal operating conditions, and
- on which overvoltages from TELECOMMUNICATION NETWORKS are possible.

1.2.8.11 TNV-2 CIRCUIT: A TNV CIRCUIT:

- whose normal operating voltages exceed the limits for an SELV CIRCUIT under normal operating conditions, and

¹A list of informative references is given in annex Q: “Bibliography”.

- which is not subject to overvoltages from TELECOMMUNICATION NETWORKS.

1.2.8.12 TNV-3 CIRCUIT: A TNV CIRCUIT:

- whose normal operating voltages exceed the limits for an SELV CIRCUIT under normal operating conditions; and
- on which overvoltages from TELECOMMUNICATION NETWORKS are possible.

1.2.9 Insulation

1.2.9.1 FUNCTIONAL INSULATION: Insulation that is necessary only for the correct operation of the equipment.

NOTE – FUNCTIONAL INSULATION by definition does not protect against electric shock. It may, however, reduce the likelihood of ignition and fire.

1.2.9.2 BASIC INSULATION: Insulation to provide basic protection against electric shock.

1.2.9.3 SUPPLEMENTARY INSULATION: Independent insulation applied in addition to BASIC INSULATION in order to reduce the risk of electric shock in the event of a failure of the BASIC INSULATION.

1.2.9.4 DOUBLE INSULATION: Insulation comprising both BASIC INSULATION and SUPPLEMENTARY INSULATION.

1.2.9.5 REINFORCED INSULATION: A single insulation system which provides a degree of protection against electric shock equivalent to DOUBLE INSULATION under the conditions specified in this standard.

NOTE – The term “insulation system” does not imply that the insulation has to be in one homogeneous piece. It may comprise several layers which cannot be tested as SUPPLEMENTARY OF BASIC INSULATION.

1.2.9.6 WORKING VOLTAGE: The highest voltage to which the insulation or the component under consideration is, or can be, subjected when the equipment is operating under conditions of normal use.

1.2.9.7 PEAK WORKING VOLTAGE: The highest peak or d.c. value of a WORKING VOLTAGE, including repetitive peak impulses generated in the equipment, but not including external transients.

1.2.9.8 REQUIRED WITHSTAND VOLTAGE: The peak voltage that the insulation under consideration is required to withstand.

1.2.9.9 MAINS TRANSIENT VOLTAGE: The highest peak voltage expected at the power input to the equipment, arising from external transients on the AC MAINS SUPPLY.

1.2.9.10 TELECOMMUNICATION NETWORK TRANSIENT VOLTAGE: The highest peak voltage expected at the TELECOMMUNICATION NETWORK connection point of the equipment, arising from external transients on the network.

1.2.10 Clearances and creepage distances

1.2.10.1 CLEARANCE: The shortest distance between two conductive parts, or between a conductive part and the BOUNDING SURFACE of the equipment, measured through air.

1.2.10.2 CREEPAGE DISTANCE: The shortest path between two conductive parts, or between a conductive part and the BOUNDING SURFACE of the equipment, measured along the surface of the insulation.

1.2.10.3 BOUNDING SURFACE: The outer surface of the ELECTRICAL ENCLOSURE, considered as though metal foil were pressed into contact with accessible surfaces of insulating material.

1.2.11 Components

1.2.11.1 THERMOSTAT: A cycling temperature-sensing control, which is intended to keep a temperature between two particular values under normal operating conditions and which may have provision for setting by the OPERATOR.

1.2.11.2 TEMPERATURE LIMITER: A temperature-sensing control which is intended to keep a temperature below or above one particular value during normal operating conditions and which may have provision for setting by the OPERATOR.

NOTE – A TEMPERATURE LIMITER may be of the automatic reset or of the manual reset type.

1.2.11.3 THERMAL CUT-OUT: A temperature-sensing control intended to operate under abnormal operating conditions and which has no provision for the OPERATOR to change the temperature setting.

NOTE – A THERMAL CUT-OUT may be of the automatic reset or of the manual reset type.

1.2.11.4 THERMAL CUT-OUT, AUTOMATIC RESET: A THERMAL CUT-OUT which automatically restores the current after the relevant part of the equipment has cooled down sufficiently.

1.2.11.5 THERMAL CUT-OUT, MANUAL RESET: A THERMAL CUT-OUT which requires resetting by hand, or replacement of a part, in order to restore the current.

1.2.11.6 INTERCONNECTING CABLE: A cable that is external to the equipment and that is used to electrically connect an accessory to a unit of information technology equipment, to interconnect units in a system or to connect a unit to a TELECOMMUNICATION NETWORK; such a cable may carry any type of circuit from one unit to another.

1.2.12 Flammability

A P

1.2.12.1 FLAMMABILITY CLASSIFICATION OF MATERIALS: The recognition of the burning behaviour of materials and their ability to extinguish if ignited. Materials are classified as in 1.2.12.2 to 1.2.12.9 when tested in accordance with annex A.

NOTE 1 – When applying the requirements in this standard, HF-1 CLASS FOAMED MATERIALS are regarded as better than those of CLASS HF-2, and CLASS HF-2 better than HBF.

NOTE 2 – Similarly, other MATERIALS, including rigid (engineering structural) foam of CLASSES 5V or V-0 are regarded as better than those of CLASS V-1, V-1 better than V-2, and V-2 better than HB.

1.2.12.2 V-0 CLASS MATERIAL: A material that, when tested in accordance with A.6, may flame or glow but will meet certain criteria for times to extinguish; glowing particles or flaming drops released do not ignite surgical cotton.

1.2.12.3 V-1 CLASS MATERIAL: A material that, when tested in accordance with A.6, may flame or glow but will meet certain criteria for times to extinguish; glowing particles or flaming drops released do not ignite surgical cotton.

1.2.12.4 V-2 CLASS MATERIAL: A material that, when tested in accordance with A.6, may flame or glow but will meet certain criteria for times to extinguish; glowing particles or flaming drops released may ignite surgical cotton.

1.2.12.5 5V CLASS MATERIAL: A material that, when tested in accordance with A.9, may flame or glow but will extinguish within a prescribed period of time; glowing particles or flaming drops released do not ignite surgical cotton.

1.2.12.6 HF-1 CLASS FOAMED MATERIAL: A foamed material that, when tested in accordance with A.7, may flame or glow but will extinguish within a prescribed period of time; flaming or glowing particles, or flaming drops released do not ignite surgical cotton.

1.2.12.7 HF-2 CLASS FOAMED MATERIAL: A foamed material that, when tested in accordance with A.7, may flame or glow but will extinguish within a prescribed period of time; flaming or glowing particles, or flaming drops released may ignite surgical cotton.

1.2.12.8 HB CLASS MATERIAL: Material that, when tested in accordance with A.8, does not exceed a specified maximum burning rate.

1.2.12.9 HBF CLASS FOAMED MATERIAL: A foamed material that, when tested in accordance with A.7, does not exceed a specified maximum burning rate.

1.2.12.10 EXPLOSION LIMIT: The lowest concentration of a combustible material in a mixture containing any of the following: gases, vapours, mists or dusts, in which a flame is able to propagate after removal of the ignition source.

1.2.13 Miscellaneous

P

1.2.13.1 TYPE TEST: A test on a representative sample of the equipment with the objective of determining if the equipment, as designed and manufactured, can meet the requirements of this standard.

1.2.13.2 SAMPLING TEST: A test on a number of samples taken at random from a batch. [IEV 151-04-17, modified]¹⁾

1.2.13.3 ROUTINE TEST: A test to which each individual sample is subjected during or after manufacture to check if the sample complies with certain criteria [IEV 151-04-16, modified].

1.2.13.4 DC VOLTAGE: The average value of a voltage (as measured by a moving coil meter) having a peak-to-peak ripple not exceeding 10 % of the average value.

NOTE – Where peak-to-peak ripple exceeds 10 % of the average value, the requirements related to peak voltage are applicable.

1.2.13.5 SERVICE PERSONNEL: Persons having appropriate technical training and experience necessary to be aware of hazards to which they may be exposed in performing a task and of measures to minimize the risks for themselves or other persons.

1.2.13.6 USER: Any person, other than SERVICE PERSONNEL. The term USER in this standard is the same as the term OPERATOR and the two can be interchanged.

1.2.13.7 OPERATOR: See USER (1.2.13.6).

1.2.13.8 TELECOMMUNICATION NETWORK: A metallicly terminated transmission medium intended for communication between equipment that may be located in separate buildings, excluding:

- the mains system for supply, transmission and distribution of electrical power, if used as a telecommunication transmission medium;
- television distribution systems using cable;
- SELV CIRCUITS connecting units of data processing equipment.

NOTE 1 – The term TELECOMMUNICATION NETWORK is defined in terms of its functionality, not its electrical characteristics. A TELECOMMUNICATION NETWORK is not itself defined as being either an SELV CIRCUIT or a TNV CIRCUIT. Only the circuits in the equipment are so classified.

NOTE 2 – A TELECOMMUNICATION NETWORK may be

- publicly or privately owned;
- subject to transient overvoltages due to atmospheric discharges and faults in power distribution systems;
- subject to longitudinal (common mode) voltages induced from nearby power lines or electric traction lines.

NOTE 3 – Examples of TELECOMMUNICATION NETWORKS are:

- a public switched telephone network;
- a public data network;
- an Integrated Services Digital Network (ISDN);
- a private network with electrical interface characteristics similar to the above.

¹A list of normative references is given in annex P.

1.2.13.9 FUNCTIONAL EARTHING: The earthing of a point in equipment or in a system, which is necessary for a purpose other than safety. [IEV 195-01-13, modified]

1.2.13.10 PROTECTIVE EARTHING CONDUCTOR: A conductor in the building installation wiring, or in the power supply cord, connecting a main protective earthing terminal in the equipment to an earth point in the building installation.

NOTE – In some countries, the term “grounding conductor” is used instead of “PROTECTIVE EARTHING CONDUCTOR”.

1.2.13.11 PROTECTIVE BONDING CONDUCTOR: A conductor in the equipment, or a combination of conductive parts in the equipment, connecting a main protective earthing terminal to a part of the equipment that is required to be earthed for safety purposes.

1.2.13.12 TOUCH CURRENT: Electric current through a human body when it touches one or more accessible parts. [IEV 195-05-21, modified]¹⁾

NOTE – TOUCH CURRENT was previously included in the term “leakage current”.

1.2.13.13 PROTECTIVE CONDUCTOR CURRENT: Current flowing through the PROTECTIVE EARTHING CONDUCTOR under normal operating conditions.

NOTE – PROTECTIVE CONDUCTOR CURRENT was previously included in the term “leakage current”.

1.3 General requirements

1.3.1 Application of requirements

The requirements detailed in this standard shall be applied only if safety is involved.

In order to establish whether or not safety is involved, the circuits and construction shall be carefully investigated to take into account the consequences of possible failures.

1.3.2 Equipment design and construction

Equipment shall be so designed and constructed that, under all conditions of normal use and under likely abnormal use or single fault conditions (see 1.4.14), protection is provided to reduce the risk of personal injury from electric shock and other hazards, and against spread of fire originating in the equipment.

Compliance is checked by inspection and by the relevant tests.

¹⁾To be published.

1.3.3 Supply voltage

Equipment shall be designed to be safe at any supply voltage to which it is intended to be connected.

Compliance is checked by inspection and by carrying out the relevant tests of this standard under the conditions specified in 1.4.5.

1.3.4 Constructions not specifically covered

Where the equipment involves technologies and materials or methods of construction not specifically covered in this standard, the equipment shall provide a level of safety not less than that generally afforded by this standard and the Principles of Safety contained herein.

NOTE – The need for additional detailed requirements to cope with a new situation should be brought promptly to the attention of the appropriate committee.

1.3.5 Equivalent materials

Where the standard specifies a particular grade of insulation, the use of a better grade of insulation is permitted. Similarly, where the standard requires material of a particular FLAMMABILITY CLASS, the use of a better class is permitted.

1.3.6 Orientation during transport and use

Where it is clear that the orientation of use of equipment is likely to have a significant effect on the application of the requirements or the results of tests, all orientations of use permitted in the installation or USER instructions shall be taken into account. For TRANSPORTABLE EQUIPMENT, all orientations of transport and use shall be taken into account.

NOTE – The above may apply to 4.1, 4.5, 4.6 and 5.3.

1.3.7 Choice of criteria

Where the standard permits a choice between different criteria for compliance, or between different methods or conditions of test, the choice is specified by the manufacturer.

1.3.8 Examples mentioned in the standard

Where examples of equipment, parts, methods of construction, design techniques and faults are given in the standard, prefaced by "e.g." or "such as", other examples are not excluded.

1.3.9 Conductive liquids

For the electrical requirements of this standard, conductive liquids shall be treated as conductive parts.

1.4 General conditions for tests

1.4.1 Application of tests

NAD

The tests detailed in this standard shall be carried out only if safety is involved.

If it is evident from the design and construction of the equipment that a particular test is not applicable, the test is not made.

Unless otherwise stated, upon conclusion of the tests, the equipment need not be operational.

1.4.2 Type tests

Except where otherwise stated, the tests specified in this standard are TYPE TESTS.

1.4.3 Test samples

Unless otherwise specified, the sample or samples under test shall be representative of the equipment the USER would receive, or shall be the actual equipment ready for shipment to the USER.

As an alternative to carrying out tests on the complete equipment, tests may be carried out separately on circuits, components or subassemblies outside the equipment, provided that inspection of the equipment and circuit arrangements indicates that the results of such testing will be representative of the results of testing the assembled equipment. If any such test indicates a likelihood of non-conformance in the complete equipment, the test shall be repeated in the equipment.

If a test specified in this standard could be destructive, it is permitted to use a model to represent the condition to be evaluated.

NOTE 1 – The tests should be carried out in the following order:

- component or material pre-selection;
- component or subassembly bench tests;
- tests where the equipment is not energized;
- live tests:
 - under normal operating conditions;
 - under abnormal operating conditions;
 - involving likely destruction.

NOTE 2 – In view of the amount of resource involved in testing and in order to minimize waste, it is recommended that all parties concerned jointly consider the test programme, the test samples and the test sequence.

1.4.4 Operating parameters for tests

Except where specific test conditions are stated elsewhere in the standard and where it is clear that there is a significant impact on the results of the test, the tests shall be carried out under the most unfavourable combination within the manufacturer's operating specifications of the parameters:

- supply voltage (see 1.4.5);
- supply frequency (see 1.4.6);
- physical location of equipment and position of movable parts;
- operating mode;
- adjustment of THERMOSTATS, regulating devices or similar controls in OPERATOR ACCESS AREAS, which are:
 - adjustable without the use of a TOOL; or
 - adjustable using a means, such as a key or a TOOL, deliberately provided for the OPERATOR.

1.4.5 Supply voltage for tests

In determining the most unfavourable voltage for the power to energize the equipment under test (EUT), the following variables shall be taken into account:

- multiple RATED VOLTAGES;
- tolerances on RATED VOLTAGE as specified below;
- extremes of RATED VOLTAGE RANGES.

If the equipment is intended for direct connection to an AC MAINS SUPPLY, the tolerances on RATED VOLTAGE shall be taken as +6 % and -10 %, unless:

- the RATED VOLTAGE is 230 V single-phase or 400 V three-phase, in which case the tolerance shall be taken as +10 % and -10 %; or
- a wider tolerance is declared by the manufacturer, in which case the tolerance shall be taken as this wider value.

If the equipment is intended only for connection to an a.c. mains equivalent source, such as a motor-driven generator or an uninterruptible power supply (see 1.2.8.1), or a source other than an AC MAINS SUPPLY, the tolerances on RATED VOLTAGE shall be declared by the manufacturer.

When testing equipment designed for d.c. only, the possible influence of polarity shall be taken into account.

1.4.6 Supply frequency for tests

In determining the most unfavourable frequency for the power to energize the EUT, different RATED FREQUENCIES within the RATED FREQUENCY RANGE shall be taken into account (e.g. 50 Hz and 60 Hz) but consideration of the tolerance on a RATED FREQUENCY (e.g. 50 Hz \pm 0,5 Hz) is not normally necessary.

1.4.7 Electrical measuring instruments

Electrical measuring instruments shall have adequate bandwidth to provide accurate readings, taking into account all components (d.c., AC MAINS SUPPLY frequency, high frequency and harmonic content) of the parameter being measured. If the r.m.s. value is being measured, care shall be taken that measuring instruments give true r.m.s. readings of non-sinusoidal waveforms as well as sinusoidal waveforms.

1.4.8 Normal operating voltages

For the assessment of voltages in ELV CIRCUITS, SELV CIRCUITS and TNV CIRCUITS:

- consideration shall be given both to normal operating voltages generated internally in the equipment and to those generated externally; and
- voltages other than normal operating voltages, such as earth potential rises and induced voltages from power lines and from electric traction lines, shall not be considered.

1.4.9 Measurement of voltage to earth

Where the standard specifies a voltage between a conductive part and earth, all of the following earthed parts are considered:

- the protective earthing terminal (if any); and
- any other conductive part required to be connected to protective earth (for example, see 2.6.1); and
- any conductive part that is earthed within the equipment for functional reasons.

Parts that will be earthed in the application by connection to other equipment, but are unearthed in the equipment as tested, shall be connected to earth at the point by which the highest voltage is obtained. When measuring a voltage between earth and a conductor in a circuit that will not be earthed in the intended application of the equipment, a non-inductive resistor of 5 000 $\Omega \pm 10 \%$ shall be connected across the voltage measuring instrument.

Voltage drop in the PROTECTIVE EARTHING CONDUCTOR of the power supply cord, or in an earthed conductor in other external wiring, is not included in the measurements.

1.4.10 Loading configuration of the EUT

In determining the input current, and where other test results could be affected, the following variables shall be considered and adjusted to give the most unfavourable results:

- loads due to optional features, offered or provided by the manufacturer for inclusion in or with the EUT;
- loads due to other units of equipment intended by the manufacturer to draw power from the EUT;
- loads which could be connected to any standard supply outlets in OPERATOR ACCESS AREAS on the equipment, up to the value indicated in the marking required by 1.7.5.

It is permitted to use artificial loads to simulate such loads during testing.

1.4.11 Power from a telecommunication network

For the purpose of this standard, the power available from a TELECOMMUNICATION NETWORK is considered to be limited to 15 VA.

1.4.12 Temperature measurement conditions

P

Where a maximum temperature (T_{\max}) or a maximum temperature rise (ΔT_{\max}) is specified for compliance with tests, it is based on the assumption that the room ambient air temperature will be 25 °C when the equipment is operating. However, the manufacturer is permitted to specify a higher ambient air temperature.

It is not necessary to control the ambient temperature (T_{amb}) at a specific value during tests, but it shall be monitored and recorded.

Temperatures measured on the equipment shall conform with one of the following conditions, all temperatures being in °C.

If T_{\max} is specified: $(T - T_{\text{amb}}) \leq (T_{\max} - T_{\text{mra}})$

If ΔT_{\max} is specified: $(T - T_{\text{amb}}) \leq (\Delta T_{\max} + 25 - T_{\text{mra}})$

where:

T is the temperature of the given part measured under the prescribed test conditions;

T_{mra} is the maximum room ambient temperature permitted by the manufacturer's specification or 25 °C, whichever is greater.

During the test, the room ambient temperature should not exceed T_{mra} unless agreed by all parties involved.

1.4.13 Temperature measurement methods

E

Unless a particular method is specified, the temperatures of windings shall be determined either by the thermocouple method or by the resistance method (annex E). The temperatures of parts other than windings shall be determined by the thermocouple method. Any other suitable method of temperature measurement which does not noticeably influence the thermal balance and which achieves an accuracy sufficient to show compliance is also permitted. The choice of and position of temperature sensors shall be made so that they have minimum effect on the temperature of the part under test.

1.4.14 Simulated faults and abnormal conditions

Where it is required to apply simulated faults or abnormal operating conditions, these shall be applied in turn and one at a time. Faults which are the direct consequence of a simulated fault or abnormal operating condition are considered to be part of that simulated fault or abnormal operating condition.

When applying simulated faults or abnormal operating conditions, parts, supplies, consumable materials, media and recording materials shall be in place if they are likely to have an effect on the outcome of the test.

Where there is a specific reference to a single fault, the single fault consists of a single failure of any insulation (excluding DOUBLE INSULATION OR REINFORCED INSULATION) or a single failure of any component (excluding components with DOUBLE INSULATION OR REINFORCED INSULATION).

The equipment, circuit diagrams and component specifications are examined to determine those fault conditions that might reasonably be expected to occur. Examples include:

- short circuits and open circuits of semiconductor devices and capacitors;
- faults causing continuous dissipation in resistors designed for intermittent dissipation;
- internal faults in integrated circuits causing excessive dissipation;
- failure of BASIC INSULATION between current-carrying parts of the PRIMARY CIRCUIT and
 - accessible conductive parts;
 - earthed conductive screens;
 - parts of SELV CIRCUITS;
 - parts of LIMITED CURRENT CIRCUITS.

1.5 Components

P

1.5.1 General

Where safety is involved, components shall comply either with the requirements of this standard or with the safety aspects of the relevant IEC component standards.

NOTE 1 – An IEC component standard is considered relevant only if the component in question clearly falls within its scope.

In this standard, certain IEC component standard requirements are replaced by the relevant requirements of component standards as listed in annex P.1. DC
DC

In this standard, certain requirements (such as flammability tests) are alternatively satisfied by complying with relevant requirements of component standards as listed in annex P.2. DC
DC

A component which is to be connected to an SELV CIRCUIT and also to an ELV CIRCUIT or to a part at HAZARDOUS VOLTAGE shall comply with the requirements of 2.2.

NOTE 2 – An example of such a component is a relay with different supplies connected to different elements (coils and contacts).

1.5.2 Evaluation and testing of components

Evaluation and testing of components shall be carried out as follows:

K P

– *a component that has been demonstrated to comply with a standard harmonized with the relevant IEC component standard shall be checked for correct application and use in accordance with its rating. It shall be subjected to the applicable tests of this standard as part of the equipment with the exception of those tests which are part of the relevant IEC component standard;*

– *a component that has not been demonstrated to comply with a relevant standard as above shall be checked for correct application and use in accordance with its specified rating. It shall be subjected to the applicable tests of this standard, as part of the equipment, and to the applicable tests of the component standard, under the conditions occurring in the equipment;*

NOTE – The applicable test for compliance with a component standard is, in general, carried out separately.

– *where no relevant IEC component standard exists, or where components are used in circuits not in accordance with their specified ratings, the components shall be tested under the conditions occurring in the equipment. The number of samples required for test is, in general, the same as required by an equivalent standard.*

1.5.3 Thermal controls

Thermal controls shall be tested in accordance with annex K.

1.5.4 Transformers

CP

Transformers shall comply with the relevant requirements of this standard, including those of annex C.

1.5.5 Interconnecting cables

**NAA
NAE**

INTERCONNECTING CABLES provided as part of the equipment shall comply with the relevant requirements of this standard and shall not present a hazard in the meaning of this standard whether they are detachable or non-detachable.

INTERCONNECTING CABLES used for external interconnection between parts of equipment or between components of a system shall be constructed of cable acceptable for external use and be rated for the application with respect to voltage, current, anticipated temperature, flammability, mechanical serviceability and the like. D1
D1
D1
D1

Cable assemblies with lengths external to the unit not exceeding 3.05 m, coiled or uncoiled, may be constructed of jacketed appliance wiring material, suitable for the maximum voltage, current and temperature, rated VW-1 or FT-1 or better. Cable assemblies or wiring with lengths external to the unit not exceeding 3.05 m, coiled or uncoiled, and supplied by a limited power source or NEC Class 2 source of supply as defined in the National Electrical Code, ANSI/NFPA 70, may be constructed of materials rated VW-1 or FT-1 or better with no additional requirements. D1
D1
D1
D1
D1
D1

Compliance is checked by inspection. D1

1.5.6 Capacitors in primary circuits

P

A capacitor connected between two line conductors of the PRIMARY CIRCUIT, or between one line conductor and the neutral conductor, shall comply with IEC 60384-14: 1993, subclass X1 or X2. The duration of the damp heat, steady state test as specified in 4.12 of IEC 60384-14: 1993, shall be 21 days.

A capacitor connected between the PRIMARY CIRCUIT and protective earth shall comply with IEC 60384-14: 1993, subclass Y1, Y2 or Y4, as applicable. DE

NOTE – The above requirement does not apply to capacitors connected from a HAZARDOUS VOLTAGE SECONDARY CIRCUIT to earth. For such capacitors, the electric strength test of 5.2.2 is considered sufficient.

Compliance is checked by inspection.

1.5.7 Double or reinforced insulation bridged by components

Compliance with 1.5.7.1 to 1.5.7.3 is checked by inspection and relevant tests.

1.5.7.1 Bridging capacitors

P

It is permitted to bridge DOUBLE OR REINFORCED INSULATION by:

- a single capacitor complying with IEC 60384-14: 1993, subclass Y1; or
- two capacitors in series, each complying with IEC 60384-14: 1993, subclass Y2 or Y4.

A Y1 capacitor is considered to have REINFORCED INSULATION.

Where two capacitors are used in series, they shall each be rated for the total WORKING VOLTAGE across the pair and shall have the same nominal capacitance value.

1.5.7.2 Bridging resistors

It is permitted to bridge DOUBLE OR REINFORCED INSULATION by two resistors in series. They shall each comply with the requirements of 2.10.3 and 2.10.4 between their terminations for the total WORKING VOLTAGE across the pair and shall have the same nominal resistance value.

1.5.7.3 Accessible parts

Where accessible conductive parts or circuits are separated from other parts by DOUBLE OR REINFORCED INSULATION that is bridged by components in accordance with 1.5.7.1 or 1.5.7.2, the accessible parts shall comply with the requirements for LIMITED CURRENT CIRCUITS in 2.4. These requirements shall apply after electric strength testing of the insulation has been carried out.

1.5.8 Components in equipment for IT power systems

P

For equipment to be connected to IT power systems, components connected between line and earth shall be capable of withstanding the stress due to the line-to-line voltage. However, capacitors rated for the applicable line-to-neutral voltage are permitted in such applications if they comply with IEC 60384-14: 1993, subclass Y1, Y2 or Y4.

NOTE 1 – The above capacitors are endurance tested at 1,7 times the voltage rating of the capacitor.

NOTE 2 – In Norway, due to the IT power distribution system used (see annex V, figure V.7), capacitors are required to be rated for the applicable line-to-line voltage.

Compliance is checked by inspection.

1.6 Power interface

1.6.1 AC power distribution systems

AC power distribution systems are classified as TN, TT or IT (see annex V).

NOTE – In Australia, TN-S and other systems apply.

1.6.2 Input current

The steady state input current of the equipment shall not exceed the RATED CURRENT by more than 10 % under NORMAL LOAD.

Compliance is checked by measuring the input current of the equipment at NORMAL LOAD under the following conditions:

- where an equipment has more than one RATED VOLTAGE, the input current is measured at each RATED VOLTAGE;*
- where an equipment has one or more RATED VOLTAGE RANGES, the input current is measured at each end of each RATED VOLTAGE RANGE. Where a single value of RATED CURRENT is marked (see 1.7.1), it is compared with the higher value of input current measured in the associated voltage range. Where two values of RATED CURRENT are marked, separated by a hyphen, they are compared with the two values measured in the associated voltage range.*

In each case, the readings are taken when the input current has stabilized. If the current varies during the normal operating cycle, the steady-state current is taken as the mean indication of the value, measured on a recording r.m.s. ammeter, during a representative period.

1.6.3 Voltage limit of hand-held equipment

The RATED VOLTAGE of HAND-HELD EQUIPMENT shall not exceed 250 V.

Compliance is checked by inspection.

1.6.4 Neutral connector

The neutral conductor, if any, shall be insulated from earth and from the BODY throughout the equipment as if it were a line conductor. Components connected between neutral and earth shall be rated for line-to-neutral voltage.

Compliance is checked by inspection.

1.7 Markings and instructions

NAA

NOTE – Additional requirements for markings and instructions are contained in the following subclauses:

- 2.1.1.2 USER access within battery compartments
 - 2.6.1 Unearthed parts in SERVICE ACCESS AREAS
 - 2.7.1 Protection provided by the building installation
 - 2.7.6 Neutral fusing
 - 3.4.11 Multiple power sources
 - 4.1 Equipment stability
 - 4.3.3 Adjustable controls
 - 4.3.5 Connection of plugs and sockets
 - 4.4.2 Hazardous moving parts
 - 4.6.2 Stationary equipment on non-combustible floors
 - 5.1.7 TOUCH CURRENT exceeding 3,5 mA
 - 5.1.8.2 Summation of TOUCH CURRENTS
 - 6.1.2.2 Earthing of equipment connected to the TELECOMMUNICATION NETWORK
- Annex NAA

D2

1.7.1 Power rating

**P
NAA
NAE**

Equipment shall be provided with a power rating marking, the purpose of which is to specify a supply of correct voltage and frequency, and of adequate current-carrying capacity.

If a unit is not provided with a means for direct connection to the AC MAINS SUPPLY, it need not be marked with any electrical rating, such as its RATED VOLTAGE, RATED CURRENT OR RATED FREQUENCY.

For equipment intended to be installed by an OPERATOR, the marking shall be readily visible in an OPERATOR ACCESS AREA, including any area that is directly visible only after an OPERATOR has opened a door or cover. If a manual voltage selector is not OPERATOR-accessible, the marking shall indicate the RATED VOLTAGE for which the equipment is set during manufacture; a temporary marker is permitted for this purpose. Marking is permitted on any outer surface of the equipment, except the bottom of equipment having a mass exceeding 18 kg. Additionally, on STATIONARY EQUIPMENT, the marking shall be visible after the equipment has been installed as in normal use.

For equipment intended to be installed by SERVICE PERSONNEL, and if the marking is in a SERVICE ACCESS AREA, the location of the permanent marking shall be indicated in the installation instructions or on a readily visible marker on the equipment. It is permitted to use a temporary marker for this purpose.

The marking shall include the following:

- RATED VOLTAGE(s) OR RATED VOLTAGE RANGE(s), in volts;
 - The voltage range shall have a hyphen (-) between the minimum and maximum RATED VOLTAGES. When multiple RATED VOLTAGES OR RATED VOLTAGE RANGES are given, they shall be separated by a solidus (/).

NOTE 1 – Some examples of rated voltage markings are:

- RATED VOLTAGE RANGE: 220-240 V. This means that the equipment is designed to be connected to an AC MAINS SUPPLY having any voltage between 220 V and 240 V.
- Multiple RATED VOLTAGE: 120/230/240 V. This means that the equipment is designed to be connected to an AC MAINS SUPPLY having a voltage of 120 V or 230 V or 240 V, usually after internal adjustment.

- If equipment is to be connected to both of the line conductors and to the neutral conductor of a single-phase, 3-wire power system, the marking shall give the line-to-neutral voltage and the line-to-line voltage, separated by a solidus (/), with the added notation "Three wires plus protective earth", "3W + PE" or equivalent.

NOTE 2 – Some examples of the above system rating markings are:

120/240 V; 3 wire + PE
 120/240 V; 3W + ⊕ (60417-1-IEC-5019)
 100/200 V; 2W + N + PE

- symbol for nature of supply, for d.c. only;
- RATED FREQUENCY OR RATED FREQUENCY RANGE, in hertz, unless the equipment is designed for d.c. only;
- RATED CURRENT, in milliamperes or amperes;
 - for equipment with multiple RATED VOLTAGES, the corresponding RATED CURRENTS shall be marked such that the different current ratings are separated by a solidus (/) and the relation between RATED VOLTAGE and associated RATED CURRENT appears distinctly;
 - equipment with a RATED VOLTAGE RANGE shall be marked with either the maximum RATED CURRENT or the current range;
 - the marking for RATED CURRENT of a group of units having a single supply connection shall be placed on the unit which is directly connected to the AC MAINS SUPPLY. The RATED CURRENT marked on that unit shall be the total maximum current that can be on circuit at the same time and shall include the combined currents to all units in the group that can be supplied simultaneously through the unit and that can be operated simultaneously.

NOTE 3 – Some examples of RATED CURRENT markings are:

- for equipment with multiple RATED VOLTAGES;
 120/240 V; 2,4/1,2 A
- for equipment with a RATED VOLTAGE RANGE:
 100-240 V; 2,8 A
 100-240 V; 2,8 – 1,1 A
 100-120 V; 2,8 A
 200-240 V; 1,4 A

It is recognized that in some regions it is customary to use a point (.) as a decimal marker instead of a comma.

- manufacturer's name or trade-mark or identification mark;
- manufacturer's model or type reference;
- symbol □ 60417-1-IEC-5172, for CLASS II EQUIPMENT only.

Additional markings are permitted, provided that they do not give rise to misunderstanding.

Where symbols are used, they shall conform to ISO 7000 or IEC 60417-1 where appropriate symbols exist.

1.7.2 Safety instructions

NAD
NAE

Sufficient information shall be provided to the USER concerning any condition necessary to ensure that, when used as prescribed by the manufacturer, the equipment is unlikely to present a hazard within the meaning of this standard.

If it is necessary to take special precautions to avoid the introduction of hazards when operating, installing, servicing, transporting or storing equipment, the necessary instructions shall be made available.

NOTE 1 – Special precautions may be necessary, for example for connection of the equipment to the supply and for the interconnection of separate units, if any.

NOTE 2 – Where appropriate, installation instructions should include reference to national wiring rules.

NOTE 3 – Servicing instructions are normally made available only to SERVICE PERSONNEL.

NOTE 4 – In Norway and Sweden, PLUGGABLE CLASS I EQUIPMENT intended for connection to a telephone network or similar communications system may require a marking stating that the equipment must be connected to an earthed mains socket-outlet.

The operating instructions and, for PLUGGABLE EQUIPMENT intended for USER installation, also the installation instructions, shall be made available to the USER.

Where the disconnect device is not incorporated in the equipment (see 3.4.3) or where the plug on the power supply cord is intended to serve as the disconnect device, the installation instructions shall state that:

- for PERMANENTLY CONNECTED EQUIPMENT, a readily accessible disconnect device shall be incorporated in the building installation wiring;
- for PLUGGABLE EQUIPMENT, the socket-outlet shall be installed near the equipment and shall be easily accessible.

For equipment that may produce ozone, the installation and operating instructions shall refer to the need to take precautions to ensure that the concentration of ozone is limited to a safe value.

NOTE 5 – The present recommended long term exposure limit for ozone is 0,1 ppm (0,2 mg/m³) calculated as an 8 h time-weighted average concentration. It should be noted that ozone is heavier than air.

1.7.3 Short duty cycles

Equipment intended for SHORT-TIME OPERATION or for INTERMITTENT OPERATION shall be marked with RATED OPERATING TIME, or RATED OPERATING TIME and rated resting time respectively, unless the operating time is limited by the construction or by the definition of its NORMAL LOAD.

The marking of SHORT-TIME OPERATION or INTERMITTENT OPERATION shall correspond to normal use.

The marking of INTERMITTENT OPERATION shall be such that the RATED OPERATING TIME precedes the rated resting time, the two markings being separated by a solidus (/).

1.7.4 Supply voltage adjustment

NAA

For equipment intended for connection to multiple RATED VOLTAGES or FREQUENCIES, the method of adjustment shall be fully described in the servicing or installation instructions.

Unless the means of adjustment is a simple control near the power rating marking, and the setting of this control is obvious by inspection, the following instruction or a similar one shall appear in or near the power rating marking:

SEE INSTALLATION INSTRUCTIONS BEFORE CONNECTING TO THE SUPPLY

1.7.5 Power outlets on the equipment

P

If any standard power supply outlet in the equipment is accessible to the OPERATOR, a marking shall be placed in the vicinity of the outlet to show the maximum load that is permitted to be connected to it.

Socket-outlets conforming to IEC 60083 are examples of standard power supply outlets.

1.7.6 Fuse identification

NAA

Marking shall be located adjacent to each fuse or fuseholder, or on the fuseholder, or in another location provided that it is obvious to which fuse the marking applies, giving the fuse current rating and, where fuses of different voltage rating value could be fitted, the fuse voltage rating.

Where fuses with special fusing characteristics such as time delay or breaking capacity are necessary, the type shall also be indicated.

For fuses not located in OPERATOR ACCESS AREAS and for soldered-in fuses located in OPERATOR ACCESS AREAS, it is permitted to provide an unambiguous cross-reference (e.g. F1, F2 etc.) to the servicing instructions which shall contain the relevant information.

NOTE – See 2.7.6 regarding other warnings to SERVICE PERSONNEL.

1.7.7 Wiring terminals

NAE

1.7.7.1 Protective earthing and bonding terminals

A wiring terminal intended for connection of a PROTECTIVE EARTHING CONDUCTOR shall be indicated by the symbol \oplus (60417-2-IEC-5019). This symbol shall not be used for other earthing terminals.

It is not a requirement to mark other terminals for PROTECTIVE BONDING CONDUCTORS, but where such terminals are marked, the symbol \equiv (60417-2-IEC-5017) shall be used.

The following situations are exempt from the above requirements:

- where terminals for the connection of a supply are provided on a component (e.g. terminal block) or subassembly (e.g. power supply), the symbol \equiv is permitted for the protective earthing terminal instead of \oplus ;
- on subassemblies or components, the symbol \oplus is permitted in place of the symbol \equiv provided that it does not give rise to confusion.

These symbols shall not be located on screws, or other parts which might be removed when conductors are being connected.

These requirements are applicable to terminals for connection of a PROTECTIVE EARTHING CONDUCTOR whether run as an integral part of a power supply cord or with supply conductors.

1.7.7.2 Terminals for a.c. mains supply conductors

For PERMANENTLY CONNECTED EQUIPMENT and equipment with ordinary NON-DETACHABLE POWER SUPPLY CORDS:

- terminals intended exclusively for connection of the AC MAINS SUPPLY neutral conductor, if any, shall be indicated by the capital letter N; and
- on three-phase equipment, if incorrect phase rotation could cause overheating or other hazard, terminals intended for connection of the AC MAINS SUPPLY line conductors shall be marked in such a way that, in conjunction with any installation instructions, the sequence of phase rotation is unambiguous.

These indications shall not be located on screws, or other parts which might be removed when conductors are being connected.

1.7.8 Controls and indicators

P

1.7.8.1 Identification, location and marking

Unless it is obviously unnecessary, indicators, switches and other controls affecting safety shall be identified or located so as to indicate clearly which function they control.

Markings and indications for switches and other controls shall be located either:

- on or adjacent to the switch or control, or
- elsewhere, provided that it is obvious to which switch or control the marking applies.

Indications used for this purpose shall, wherever practicable, be comprehensible without a knowledge of languages, national standards, etc.

1.7.8.2 Colours

Where safety is involved, colours of controls and indicators shall comply with IEC 60073. Where colours are used for functional controls or indicators, any colour, including red, is permitted provided that it is clear that safety is not involved.

1.7.8.3 Symbols

Where symbols are used on or near controls, for example switches, push buttons, etc., to indicate "ON" and "OFF" conditions, they shall be the line I for "ON" and circle O for "OFF" (60417-1-IEC-5007 and 60417-1-IEC-5008). For push-push type switches the symbol Ⓢ shall be used (60417-1-IEC-5010).

It is permitted to use the symbols O and I to indicate the "OFF" and "ON" positions of any primary or secondary power switches, including isolating switches.

A "STAND-BY" condition shall be indicated by the symbol Ⓢ (60417-1-IEC-5009).

1.7.8.4 Markings using figures

If figures are used for indicating different positions of any control, the "OFF" position shall be indicated by the figure 0 (zero) and higher figures shall be used to indicate greater output, input, etc.

1.7.9 Isolation of multiple power sources

Where there is more than one connection supplying HAZARDOUS VOLTAGES OR ENERGY LEVELS to equipment, a prominent marking close to the access for SERVICE PERSONNEL to the hazardous parts shall indicate which disconnect device or devices isolate the equipment completely and which disconnect devices can be used to isolate each section of the equipment.

1.7.10 IT power systems

If the equipment has been designed or, when required, modified for connection to an IT power system, the equipment installation instructions shall so state.

1.7.11 Thermostats and other regulating devices

THERMOSTATS and similar regulating devices intended to be adjusted during installation or in normal use shall be provided with an indication for the direction of adjustment to increase or decrease the value of the characteristic being adjusted. Indication by the symbols + and – is permitted.

1.7.12 Language

Instructions and equipment marking related to safety shall be in a language which is acceptable in the country in which the equipment is to be installed.

NOTE 1 – Documentation intended for use only by SERVICE PERSONNEL is permitted to be in the English language only.

NOTE 2 – In Germany, safety related information also for SERVICE PERSONNEL has to be in the German language.

1.7.13 Durability

P

Any marking required by this standard shall be durable and legible. In considering the durability of the marking, the effect of normal use shall be taken into account.

Compliance is checked by inspection and by rubbing the marking by hand for 15 s with a piece of cloth soaked with water and again for 15 s with a piece of cloth soaked with petroleum spirit. After this test, the marking shall be legible; it shall not be possible to remove marking plates easily and they shall show no curling.

The petroleum spirit to be used for the test is aliphatic solvent hexane having a maximum aromatics content of 0,1 % by volume, a kauri-butanol value of 29, an initial boiling point of approximately 65 °C, a dry point of approximately 69 °C and a mass per unit volume of approximately 0,7 kg/l.

1.7.14 Removable parts

Marking required by this standard shall not be placed on removable parts which can be replaced in such a way that the marking would become misleading.

1.7.15 Replaceable batteries

NAA

If an equipment is provided with a replaceable battery, and if replacement by an incorrect type could result in an explosion (e.g. with some lithium batteries), the following applies:

- if the battery is placed in an OPERATOR ACCESS AREA, there shall be a marking close to the battery or a statement in both the operating and the servicing instructions;
- if the battery is placed elsewhere in the equipment, there shall be a marking close to the battery or a statement in the servicing instructions.

This marking or statement shall include the following or similar text:

CAUTION

RISK OF EXPLOSION IF BATTERY IS REPLACED

BY AN INCORRECT TYPE.

DISPOSE OF USED BATTERIES ACCORDING

TO THE INSTRUCTIONS.

Compliance is checked by inspection.

1.7.16 Operator access with a tool

P

If a TOOL is necessary to gain access to an OPERATOR ACCESS AREA, either all other compartments within that area containing a hazard shall be inaccessible to the OPERATOR by the use of the same TOOL, or such compartments shall be marked to discourage OPERATOR access.

An acceptable marking for an electric shock hazard is ⚠ (ISO 3864, No. 5036).

1.7.17 Equipment for restricted access locations

For equipment intended only for installation in a RESTRICTED ACCESS LOCATION, the installation instructions shall contain a statement to this effect.

2 Protection from hazards

2.1 Protection from electric shock and energy hazards

NOTE – In Australia, additional requirements apply.

2.1.1 Protection in operator access areas

P

This subclause specifies requirements for protection against electric shock from energized parts based on the principle that the OPERATOR is permitted to have access to:

- bare parts of SELV CIRCUITS; and
- bare parts of LIMITED CURRENT CIRCUITS; and
- TNV CIRCUITS under the conditions specified in 2.1.1.1.

Access to other energized parts, and to their insulation, is restricted as specified in 2.1.1.1.

Additional requirements are specified in 2.1.1.5 for protection against energy hazards.

2.1.1.1 Access to energized parts

NAE

The equipment shall be so constructed that in OPERATOR ACCESS AREAS there is adequate protection against contact with:

- bare parts of ELV CIRCUITS; and
- bare parts at HAZARDOUS VOLTAGES; and
- FUNCTIONAL OR BASIC INSULATION of parts or wiring in ELV CIRCUITS, except as permitted in 2.1.1.3; and
- FUNCTIONAL OR BASIC INSULATION of parts or wiring at HAZARDOUS VOLTAGES; and

NOTE 1 – FUNCTIONAL INSULATION includes, but is not limited to, insulation, such as lacquer, solvent-based enamel, ordinary paper, cotton and oxide film, or displaceable insulation such as beads and sealing compounds other than self-hardening resin.

- unearthed conductive parts separated from ELV CIRCUITS or from parts at HAZARDOUS VOLTAGES by FUNCTIONAL OR BASIC INSULATION only; and
- bare parts of TNV CIRCUITS, except that access is permitted to:

- bare conductive parts in the interior of equipment which are normally protected against contact by a cover intended for occasional removal by the OPERATOR, such as for the installation of accessories, provided that the installation instructions include directions for the disconnection of the TNV CIRCUIT connector before removing the cover;

D3
D3
D3
D3
D3

- contacts of connectors which cannot be touched by the test probe, (figure 2C);
- bare conductive parts in the interior of a battery compartment that complies with 2.1.1.2;
- bare conductive parts of TNV-1 CIRCUITS that have any point connected in accordance with 2.6.1 e) to a protective earthing terminal;
- bare conductive parts of connectors in TNV-1 CIRCUITS that are separated from unearthed accessible conductive parts of the equipment in accordance with 6.2.1.

NOTE 2 – A typical application is the shell for a coaxial connector.

NOTE 3 – Access to TNV-1 CIRCUITS and TNV-3 CIRCUITS via other circuits is also restricted by 6.2.1 in some cases.

Unrestricted access is permitted to LIMITED CURRENT CIRCUITS.

These requirements apply for all positions of the equipment when it is wired and operated as in normal use.

Protection shall be achieved by insulation or by guarding or by the use of interlocks.

Compliance is checked by all of the following:

- a) inspection; and*
- b) a test with the test finger, figure 2A, which shall not contact parts described above when applied to openings in the ENCLOSURES after removal of parts that can be detached by an OPERATOR, including fuseholders, and with OPERATOR access doors and covers open. It is permitted to leave lamps in place for this test. Connectors that can be separated by an OPERATOR, other than plugs and socket-outlets complying with IEC 60083, shall also be tested during disconnection; and*
- c) a test with the test pin, figure 2B, which shall not contact bare parts at HAZARDOUS VOLTAGES when applied to openings in an external ELECTRICAL ENCLOSURE. Parts that can be detached by an OPERATOR, including fuseholders and lamps, are left in place, and OPERATOR access doors and covers are closed during this test; and*
- d) a test with the test probe, figure 2C, where appropriate.*

The test finger, the test pin and the test probe are applied as above, without appreciable force, in every possible position, except that floor-standing equipment having a mass exceeding 40 kg is not tilted.

Equipment intended for building-in or rack-mounting, or for incorporation in larger equipment is tested with access to the equipment limited according to the method of mounting detailed in the installation instructions.

Openings preventing the entry of the test finger, test b) above, are further tested by means of a straight unjointed version of the test finger applied with a force of 30 N. If the unjointed finger enters, test b) is repeated except that the finger is pushed through the opening using any necessary force up to 30 N.

NOTE 4 – If an electrical contact indicator is used to show contact, care should be taken to ensure that the application of the test does not damage components of electronic circuits.

The above requirements regarding contact with parts at HAZARDOUS VOLTAGE apply only to HAZARDOUS VOLTAGES not exceeding 1 000 V a.c. or 1 500 V d.c. For higher voltages, contact is not permitted, and there shall be an air gap between the part at HAZARDOUS VOLTAGE and the test finger, figure 2A, or the test pin, figure 2B, placed in its most unfavourable position. The air gap shall have a minimum length equal to the minimum CLEARANCE specified in 2.10.3 for BASIC INSULATION or withstand the relevant electric strength test in 5.2.2 (See figure F.12, point A).

If components are movable, for instance, for the purpose of belt tensioning, the test with the test finger is made with each component in its most unfavourable position within the range of adjustment, the belt being removed, if necessary, for this purpose.

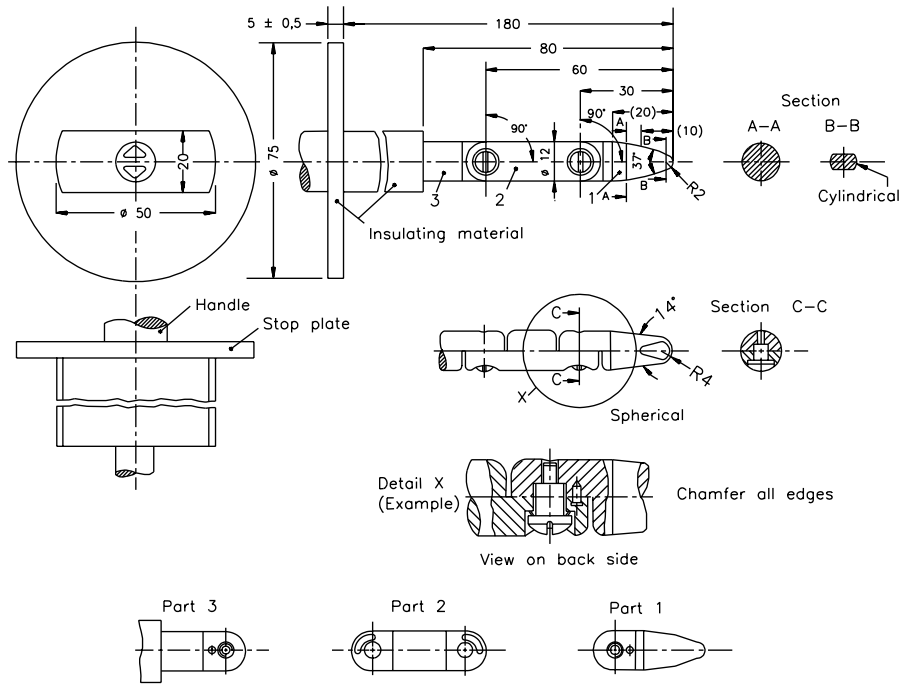

Linear dimensions in millimetres

SM471C

Linear dimensions in millimetres

Tolerances on dimensions without specific tolerances:

- for 14° and 37° angles	± 15'
- on radii:	± 0,1 mm
- on linear dimensions	
≤ 15 mm	0
> 15 mm ≤ 25 mm	- 0,1 mm
> 25 mm	± 0,1 mm
	± 0,3 mm

Material of finger: e.g. heat-treated steel

Both joints of this finger can be bent through an angle of 90° (+10°, - 0°) but in one and the same direction only.

NOTE 1 – Using the pin and groove solution is only one of the possible approaches in order to limit the bending angle to 90°. For this reason, dimensions and tolerances of these details are not given in the drawing. The actual design must insure a 90° bending angle with a 0° to +10° tolerance.

NOTE 2 – Dimensions in parentheses are for information only.

NOTE 3 – The test finger is taken from IEC 61032, figure 2, test probe B. In some cases, the tolerances are different.

Figure 2A – Test finger

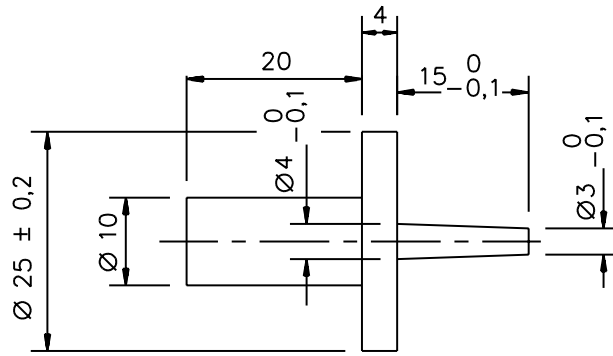

Dimensions in millimetres

S2962C

The handle dimensions ($\text{Ø } 10$ and 20) are not critical.

NOTE – The test pin dimensions are those given in IEC 61032, figure 8, test probe 13. In some cases the tolerances are different.

Figure 2B – Test pin

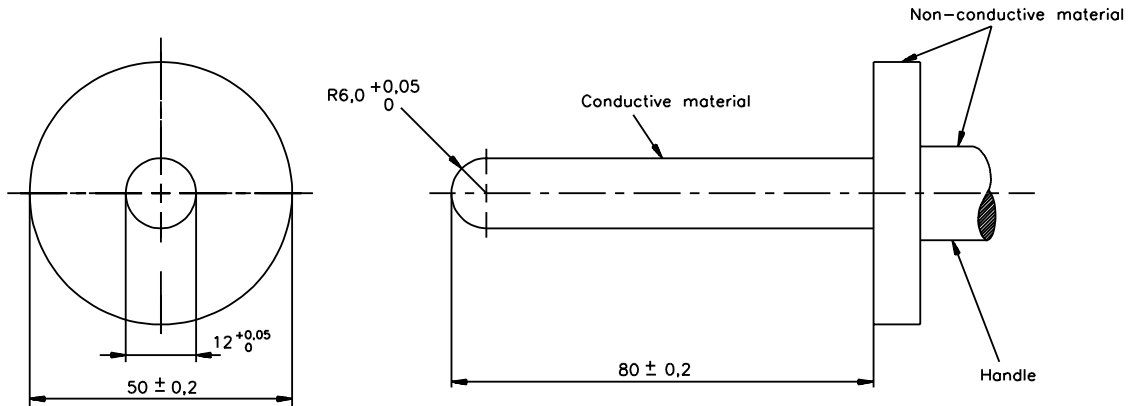

SM430C

Dimensions in millimetres

Figure 2C – Test probe

2.1.1.2 Battery compartments

Access to bare conductive parts of TNV CIRCUITS within a battery compartment in the equipment is permitted if all of the following conditions are met:

- the compartment has a door that requires a deliberate technique to open, such as use of a TOOL or latching device; and
- the TNV CIRCUIT is not accessible when the door is closed; and
- there is a marking next to the door, or on the door if the door is secured to the equipment, with instructions for protection of the USER once the door is opened.

NOTE – Information stating that the telephone cord is to be disconnected prior to opening the door is an example of an acceptable instruction.

Compliance is checked by inspection.

2.1.1.3 Access to ELV wiring

Insulation of internal wiring in an ELV CIRCUIT is permitted to be accessible to an OPERATOR, provided that :

- a) the insulation meets the requirements for SUPPLEMENTARY INSULATION detailed in 3.1.4; or;
- b) all of the following apply:
 - the wiring does not need to be handled by the OPERATOR and is so placed that the OPERATOR is unlikely to pull on it, or is so fixed that the connecting points are relieved from strain; and
 - the wiring is routed and fixed so as not to touch unearthed accessible conductive parts; and
 - the insulation passes the electric strength test of 5.2.2 for SUPPLEMENTARY INSULATION; and
 - the distance through insulation not less than that given in table 2A.

Table 2A – Distance through insulation of internal wiring

WORKING VOLTAGE (in case of failure of BASIC INSULATION)		Minimum distance through insulation
V peak or d.c.	V r.m.s. (sinusoidal)	mm
Over 71, up to 350	Over 50, up to 250	0,17
Over 350	Over 250	0,31

Compliance is checked by inspection and measurement, and by the test of 5.2.2.

2.1.1.4 Access to hazardous voltage circuit wiring

Where the insulation of internal wiring at HAZARDOUS VOLTAGE is accessible to an OPERATOR, or is not routed and fixed to prevent it from touching unearthed accessible conductive parts, it shall meet the requirements of 3.1.4 for DOUBLE OR REINFORCED INSULATION.

Compliance is checked by inspection and measurement and, if necessary, by test.

2.1.1.5 Energy hazards

There shall be no energy hazard in OPERATOR ACCESS AREAS.

Compliance is checked by means of the test finger, figure 2A (see 2.1.1.1), in a straight position, applied without appreciable force. It shall not be possible to bridge with this test finger two or more bare parts, one of which may be an earthed conductive part, between which a HAZARDOUS ENERGY LEVEL exists.

2.1.1.6 Manual controls

Conductive shafts of operating knobs, handles, levers and the like shall not be connected to parts at HAZARDOUS VOLTAGES, to ELV CIRCUITS or to TNV CIRCUITS.

In addition, conductive operating knobs, handles, levers and the like which are manually moved in normal use and which are earthed only through a pivot or bearing, shall either:

- be separated from parts at HAZARDOUS VOLTAGES by DOUBLE OR REINFORCED INSULATION; OR
- have their accessible parts covered by SUPPLEMENTARY INSULATION.

Compliance is checked by inspection.

2.1.1.7 Discharge of capacitors in the primary circuit

Equipment shall be so designed that, at an external point of disconnection of the AC MAINS SUPPLY, the risk of electric shock from stored charge on capacitors connected in the PRIMARY CIRCUIT is reduced.

Compliance is checked by inspection of the equipment and relevant circuit diagrams, taking into account the possibility of disconnection of the supply with the "ON"/"OFF" switch in either position.

Equipment is considered to comply if any capacitor having a marked or nominal capacitance exceeding 0,1 μ F and connected to the PRIMARY CIRCUIT has a means of discharge resulting in a time constant not exceeding:

- 1 s for PLUGGABLE EQUIPMENT TYPE A; and
- 10 s for PERMANENTLY CONNECTED EQUIPMENT and for PLUGGABLE EQUIPMENT TYPE B.

The relevant time constant is the product of the effective capacitance in microfarads and the effective discharge resistance in megohms. If it is difficult to determine the effective capacitance and resistance values, a measurement of voltage decay at the point of external disconnection can be used.

NOTE – During an interval equal to one time constant, the voltage will have decayed to 37 % of its original value.

2.1.2 Protection in service access areas

In a SERVICE ACCESS AREA, the following requirements apply.

Bare parts operating at HAZARDOUS VOLTAGES shall be located or guarded so that unintentional contact with such parts is unlikely during service operations involving other parts of the equipment.

Bare parts at HAZARDOUS VOLTAGE shall be located or guarded so that accidental shorting to SELV CIRCUITS or to TNV CIRCUITS, for example by TOOLS or test probes used by SERVICE PERSONNEL, is unlikely.

No requirement is specified regarding access to ELV CIRCUITS or to TNV CIRCUITS. However, bare parts that involve an energy hazard shall be located or guarded so that unintentional bridging by conductive materials that might be present is unlikely during service operations involving other parts of the equipment.

Any guards required for compliance with 2.1.2 shall be easily removable and replaceable if removal is necessary for servicing.

Compliance is checked by inspection and measurement. In deciding whether or not unintentional contact is likely, account is taken of the way SERVICE PERSONNEL need to gain access past, or near to, the bare parts in order to service other parts.

2.1.3 Protection in restricted access locations

For equipment to be installed in a RESTRICTED ACCESS LOCATION, the requirements for OPERATOR ACCESS AREAS apply, except as permitted in the following three paragraphs:

If a SECONDARY CIRCUIT at HAZARDOUS VOLTAGE is used to supply a ringing signal generator that complies with 2.3.1 b), contact with bare parts of the circuit is permitted with the test finger, figure 2A (see 2.1.1.1). However, such parts shall be so located or guarded that unintentional contact is unlikely.

Bare parts that involve an energy hazard shall be located or guarded so that unintentional bridging by conductive materials that might be present is unlikely.

No requirement is specified regarding contact with bare parts of TNV-1, TNV-2, and TNV-3 CIRCUITS.

Compliance is checked by inspection and measurement. In deciding whether or not unintentional contact is likely, account is taken of the need to gain access past, or near to, the bare parts.

2.2 SELV circuits

2.2.1 General requirements

SELV CIRCUITS shall exhibit voltages that are safe to touch both under normal operating conditions and after a single fault (see 1.4.14).

Compliance with 2.2.1 to 2.2.4 is checked by inspection and relevant tests.

2.2.2 Voltages under normal conditions

In a single SELV CIRCUIT or in interconnected SELV CIRCUITS, the voltage between any two conductors of the SELV CIRCUIT or CIRCUITS and, between any one such conductor and earth (see 1.4.9), shall not exceed 42,4 V peak, or 60 V d.c., under normal operating conditions.

NOTE – A circuit that meets the above requirements, but that is subject to overvoltages from a TELECOMMUNICATION NETWORK, is a TNV-1 CIRCUIT.

2.2.3 Voltages under fault conditions

Except as permitted in 2.3.2, in the event of a single fault (see 1.4.14), the voltages between any two conductors of the SELV CIRCUIT OR CIRCUITS and between any one such conductor and earth (see 1.4.9) shall not exceed 42,4 V peak, or 60 V d.c., for longer than 0,2 s. Moreover, a limit of 71 V peak, or 120 V d.c., shall not be exceeded.

NOTE – In Canada and the United States, the exception mentioned in 2.3.2 is not permitted.

Except as permitted in 2.2.4, one of the methods specified in 2.2.3.1, 2.2.3.2, or 2.2.3.3 shall be used.

It is permitted for some parts of a circuit (e.g. a transformer-rectifier circuit) to comply with all of the requirements for SELV CIRCUITS and to be OPERATOR-accessible, while other parts of the same circuit do not comply with all of the requirements for SELV CIRCUITS and are therefore not permitted to be OPERATOR-accessible.

2.2.3.1 Separation by double or reinforced insulation (Method 1)

Where an SELV CIRCUIT is separated from other circuits by DOUBLE OR REINFORCED INSULATION only, one of the following constructions shall be used:

- provide permanent separation by barriers, routing or fixing; or
- provide insulation of all adjacent wiring involved that is rated for the highest WORKING VOLTAGE present; or
- provide insulation on either the wiring of the SELV CIRCUIT or that of the other circuits that meets the insulation requirements for SUPPLEMENTARY OR REINFORCED INSULATION, as appropriate, for the highest WORKING VOLTAGE present; or
- provide an additional layer of insulation, where required, over either the wiring of the SELV CIRCUIT or that of the other circuits; or
- provide two separate transformers in tandem, where one transformer provides BASIC INSULATION and the other transformer provides SUPPLEMENTARY INSULATION; OR
- use any other means providing equivalent insulation.

2.2.3.2 Separation by earthed screen (Method 2)

Where SELV CIRCUITS are separated from parts at HAZARDOUS VOLTAGE by an earthed screen or other earthed conductive parts, the parts at HAZARDOUS VOLTAGE shall be separated from the earthed parts by BASIC INSULATION. The earthed parts shall comply with 2.6.

2.2.3.3 Protection by earthing of the SELV circuit (Method 3)

Parts of SELV CIRCUITS protected by earthing shall be connected to a protective earthing terminal in such a way that the requirements of 2.2.3 are met by relative circuit impedances or by the operation of a protective device or both. Except as permitted in 2.3.2, parts of SELV CIRCUITS shall also be separated from parts of non-SELV CIRCUITS by BASIC INSULATION. The SELV CIRCUIT shall have adequate fault current-carrying capacity to ensure operation of the protective device, if any, and to ensure that the fault current path to earth will not open (see 2.6).

NOTE 1 – Different parts of the same SELV CIRCUIT may be protected by different methods, for example:

- Method 2 within a power transformer feeding a bridge rectifier; and
- Method 1 for the a.c. SECONDARY CIRCUIT; and
- Method 3 at the output of the bridge rectifier.

NOTE 2 – For normal conditions the SELV CIRCUIT voltage limit is the same for an ELV CIRCUIT; an SELV CIRCUIT may be regarded as an ELV CIRCUIT with additional protection under fault conditions.

2.2.4 Connection of SELV circuits to other circuits

An SELV CIRCUIT is permitted to be connected to other circuits provided that, when it is so connected, all of the following conditions are met:

- except as permitted by 1.5.7 and 2.4.3, the SELV CIRCUIT is separated by BASIC INSULATION from any PRIMARY CIRCUIT (including the neutral) within the equipment; and
- the SELV CIRCUIT meets the limits of 2.2.2 under normal operating conditions; and
- except as specified in 2.3.2, the SELV CIRCUIT meets the limits of 2.2.3 in the event of a single fault (see 1.4.14) in the SELV CIRCUIT or of in the SECONDARY CIRCUIT to which it is connected.

If a SELV CIRCUIT is connected to one or more other circuits, the SELV CIRCUIT is that part which complies with the requirements of 2.2.2 and 2.2.3.

If an SELV CIRCUIT obtains its supply conductively from a SECONDARY CIRCUIT which is separated from a HAZARDOUS VOLTAGE circuit by either:

- DOUBLE INSULATION OR REINFORCED INSULATION, OR
- an earthed conductive screen that is separated from the HAZARDOUS VOLTAGE circuit by BASIC INSULATION;

the SELV CIRCUIT shall be considered as being separated from the HAZARDOUS VOLTAGE circuit by the same method.

NOTE – For requirements in Norway, see 1.7.2, note 4 and 6.1.2.1, note 3 2.

DE

2.3 TNV circuits

2.3.1 Limits

M

In a single TNV CIRCUIT or interconnected TNV CIRCUITS, the voltage between any two conductors of the TNV CIRCUIT or CIRCUITS and between any one such conductor and earth (see 1.4.9) shall comply with the following:

a) TNV-1 CIRCUITS

The voltages do not exceed the following:

- the limits in 2.2.2 for an SELV CIRCUIT under normal operating conditions;
- the limits of figure 2D measured across a 5 000 Ω ± 2 % resistor in the event of a single fault (see 1.4.14) within the equipment.

NOTE 1 – In the event of a single insulation or component failure, the limit after 200 ms is the limit in 2.3.1 b) for a TNV-2 or TNV-3CIRCUIT for normal operating conditions.

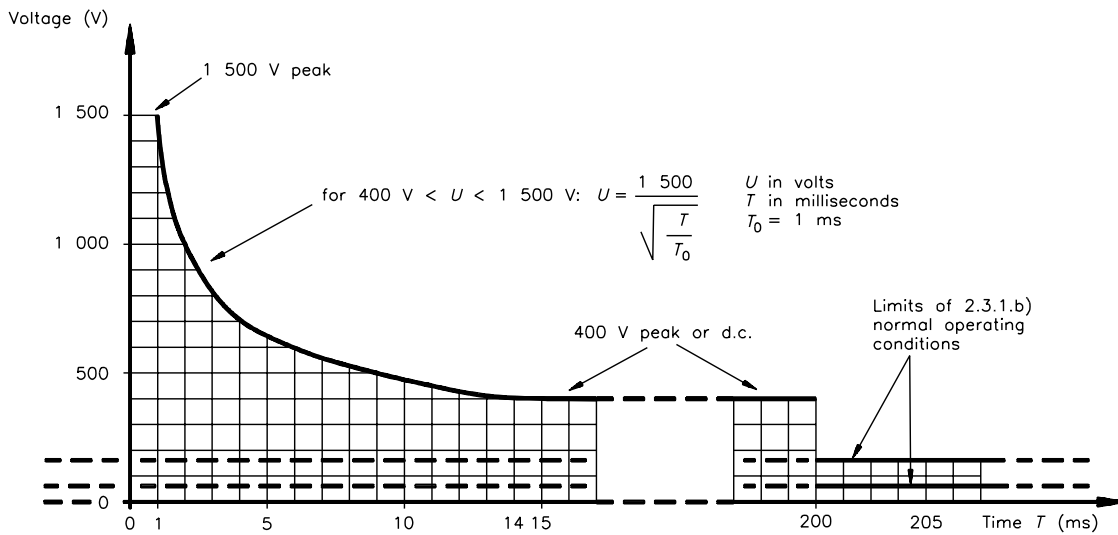

SM429C

Figure 2D – Maximum voltages permitted after a single fault

b) TNV-2CIRCUITS and TNV-3CIRCUITS

Except as permitted in 3.6, the voltages exceed the limits in 2.2.2 for an SELV CIRCUIT but do not exceed the following:

D2

- when telephone ringing signals are present, voltages such that the signal complies with the criteria of either M.2 or M.3;
- when other telephone signals are present, voltages such that the signal complies with the criteria of M.4: D2
D2
- when telephone ringing signals or other telephone signals are not present; D2
 - a combination of a.c. voltage and DC VOLTAGE under normal operating conditions such that:

$$\frac{U_{ac}}{70,7} + \frac{U_{dc}}{120} \leq 1$$

and for voltages exceeding 42.4 V peak or 60 V d.c., the current flowing through a 2 000 $\Omega \pm 2$ % resistor (or greater) connected across the voltage source with other loads disconnected does not exceed 7,1 mA peak or 30 mA d.c. D2
D2
D2
D2

where

U_{ac} is the peak value of the a.c. voltage (V) at any frequency;

U_{dc} is the value of the DC VOLTAGE (V).

NOTE 2 – When U_{dc} is zero, U_{ac} can be up to 70,7 V peak.

NOTE 3 – When U_{ac} is zero, U_{dc} can be up to 120 V.

and

- the limits of figure 2D measured across a 5 000 $\Omega \pm 2$ % resistor in the event of a single fault (see 1.4.14) within the equipment, except the current limits after 200 ms specified in figure 2D are replaced by the limits of M.3.1.4. D2
D2

Compliance is checked by inspection and measurement.

NOTE 4 – Telegraph and teletypewriter signals may be present on existing TELECOMMUNICATION NETWORKS. However, these signals are considered to be obsolescent and their characteristics are not considered in this standard.

2.3.2 Separation from other circuits and from accessible parts

NOTE 1 – See also 6.1.2 and 6.2.

Separation of SELV CIRCUITS, TNV-1CIRCUITS and accessible conductive parts from TNV-2CIRCUITS and TNV-3CIRCUITS shall be such that in the event of a single fault (see 1.4.14), the limits specified in 2.3.1 b) for TNV-2CIRCUITS and TNV-3CIRCUITS under normal operating conditions are not exceeded on the SELV CIRCUITS, TNV-1 CIRCUITS and accessible conductive parts.

NOTE 2 – In Canada and the United States, in the event of a single fault as described above, the limits of 2.2.3 apply.

NOTE 3 – Under normal operating conditions, the limits of 2.2.2 always apply to each SELV CIRCUIT and accessible conductive part.

NOTE 4 – The limits of 2.3.1 always apply to each TNV CIRCUIT.

The separation requirements will be met if BASIC INSULATION is provided as indicated in table 2G (see 2.9.5), other solutions are not excluded.

BASIC INSULATION is not required provided that all of the following are met:

- the SELV CIRCUIT, TNV-1 CIRCUIT or accessible conductive part shall be connected to a protective earthing terminal in accordance with 2.6; and
- for PLUGGABLE EQUIPMENT TYPE A, a separate protective earthing terminal shall be provided in addition to the main protective earthing terminal, if any (see 2.6.4.1). The installation instructions shall specify that this separate protective earthing terminal be permanently connected to earth; and
- for PLUGGABLE EQUIPMENT TYPE B, the equipment shall either comply with the above requirements for PLUGGABLE EQUIPMENT TYPE A or be provided with both a marking on the equipment and a statement in the installation instructions, specifying that the USER is to disconnect all TELECOMMUNICATION NETWORK connectors before disconnecting the power; and

NOTE 5 – PERMANENTLY CONNECTED EQUIPMENT is assumed to have the main protective earthing terminal permanently connected to earth.

- the test of 2.3.5 shall be carried out if the TNV-2 or TNV-3 CIRCUIT is intended to receive signals or power that are generated externally during normal operation (e.g. in a TELECOMMUNICATION NETWORK).

Enamel coating on signal transformer winding wire may be used as an alternative to BASIC INSULATION only if: D3
D3

a) ringing signals do not exceed the limits for TNV-3, D3

b) the transformer is located on the disconnect side of the switchhook, D3

c) the wire complies with the component requirements for magnet wire, and D3

d) the transformer is subjected to a 1 000 V a.c. electric strength test as a ROUTINE TEST on 100 % of production without evidence of dielectric breakdown (see 6.2.1). D3
D3

At the choice of the manufacturer, it is permitted to treat a TNV-1 CIRCUIT or a TNV-2 CIRCUIT as a TNV-3 CIRCUIT. In this case, the TNV-1 CIRCUIT or TNV-2 CIRCUIT shall meet all the separation requirements for a TNV-3 CIRCUIT.

Compliance is checked by inspection and measurement and, where necessary, by simulation of failures of components and insulation such as are likely to occur in the equipment. Prior to the tests, insulation that does not meet the requirements for BASIC INSULATION is short-circuited.

NOTE 6 – Where BASIC INSULATION is provided and 6.2.1 also applies to this insulation, the test voltage prescribed in 6.2.2 is in most cases higher than that for BASIC INSULATION.

NOTE 7 – For requirements in Norway, see 6.1.2.1, note 3 2.

DE

NOTE 8 – In Denmark, the insulation between TNV CIRCUITS and any part or circuit connected to earth shall withstand an electric strength test of 500 V a.c. r.m.s for 1 min.

2.3.3 Separation from hazardous voltages

Except as permitted in 2.3.4, TNV CIRCUITS shall be separated from circuits at HAZARDOUS VOLTAGES by one or both of the following methods:

- a) DOUBLE OR REINFORCED INSULATION;
- b) BASIC INSULATION, together with protective screening connected to the protective earthing terminal.

Compliance is checked by inspection and measurement.

NOTE 1 – In Denmark and Finland, method b) is permitted only for PERMANENTLY CONNECTED EQUIPMENT or for PLUGGABLE EQUIPMENT TYPE B.

NOTE 2 – In Norway, method b) is not permitted.

2.3.4 Connection of TNV circuits to other circuits

Except as permitted in 1.5.7, a TNV CIRCUIT is permitted to be connected to other circuits, provided that it is separated by BASIC INSULATION from any PRIMARY CIRCUIT (including the neutral) within the equipment.

NOTE 1 – The limits of 2.3.1 always apply to TNV CIRCUITS.

If a TNV CIRCUIT is connected to one or more other circuits, the TNV CIRCUIT is that part which complies with 2.3.1.

If a TNV CIRCUIT obtains its supply conductively from a SECONDARY CIRCUIT which is separated from a HAZARDOUS VOLTAGE circuit by:

- DOUBLE OR REINFORCED INSULATION; OR
- the use of an earthed conductive screen that is separated from a HAZARDOUS VOLTAGE circuit by BASIC INSULATION;

the TNV CIRCUIT shall be considered as being separated from the HAZARDOUS VOLTAGE circuit by the same method.

Compliance is checked by inspection, and by simulation of single faults (see 1.4.14) such as are likely to occur in the equipment. No such simulated fault shall cause the voltage across a $5\ 000\ \Omega \pm 2\ \%$ resistor, connected between any two conductors of the *TNV CIRCUIT* or between one such conductor and earth, to fall outside the shaded area of figure 2D (see 2.3.1). Observation is continued until stable conditions have existed for at least 5 s.

NOTE 2 – For requirements in Norway, see 6.1.2.1, note 3 2.

DE

NOTE 3 – For requirements in Finland, see 2.3.3, note 1.

2.3.5 Test for operating voltages generated externally

This test is only carried out if specified in 2.3.2.

A test generator specified by the manufacturer is used, representing the maximum normal operating voltage expected to be received from the external source. In the absence of such a specification, a test generator is used that provides $120\ V \pm 2\ V$ a.c. at 50 Hz or 60 Hz and has an internal impedance of $1\ 200\ \Omega \pm 2\ \%$.

NOTE – The above test generator is not intended to represent the actual voltages on the *TELECOMMUNICATION NETWORK* but to stress the circuit of the EUT in a repeatable manner.

*The test generator is connected between the *TELECOMMUNICATION NETWORK* terminals of the equipment. One pole of the test generator is also connected to the earthing terminal of the equipment, see figure 2E. The test voltage is applied for a maximum of 30 min. If it is clear that no further deterioration will take place, the test is terminated earlier.*

*During the test, the *SELV CIRCUIT*, *TNV-1 CIRCUIT* or accessible conductive part shall continue to comply with 2.2.2.*

*The test is repeated after reversing the connections to the *TELECOMMUNICATION NETWORK* terminals of the equipment.*

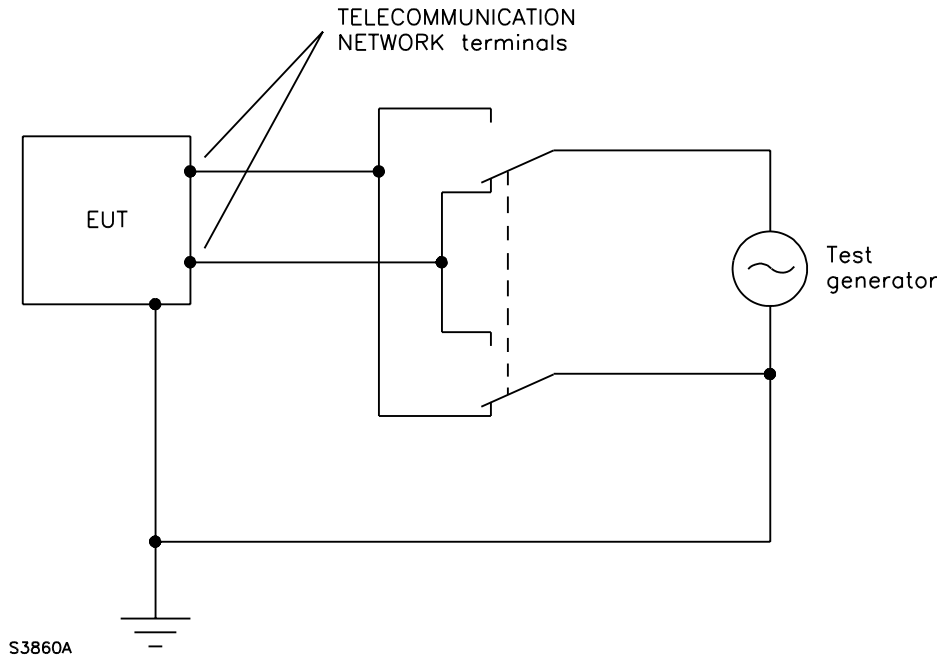

Figure 2E – Test generator

2.4 Limited current circuits

2.4.1 General requirements

LIMITED CURRENT CIRCUITS shall be so designed that the limits specified in 2.4.2 are not exceeded under normal operating conditions and in the event of a single failure within the equipment (see 1.4.14 and 1.5.7).

Except as permitted in 2.4.3, segregation of accessible parts of LIMITED CURRENT CIRCUITS from other circuits shall be as described in 2.2 for SELV CIRCUITS.

Compliance is checked by inspection and measurement.

2.4.2 Limit values

For frequencies not exceeding 1 kHz, the steady-state current drawn through a non-inductive resistor of $2\ 000\ \Omega \pm 10\ \%$ connected between any two parts of a LIMITED CURRENT CIRCUIT, or between any such part and earth (see 1.4.9), shall not exceed 0,7 mA peak, or 2 mA d.c.

For frequencies above 1 kHz, the limit of 0,7 mA is multiplied by the value of the frequency in kilohertz but shall not exceed 70 mA peak.

For parts not exceeding 450 V peak or d.c., the circuit capacitance shall not exceed 0,1 μ F.

For parts whose voltage, U , exceeds 0,45 kV peak or d.c., but does not exceed 15 kV peak or d.c., the circuit capacitance shall not exceed $45/U$ nF, where U is expressed in kilovolts.

NOTE 1 – The limit of $45/U$ corresponds to an available stored charge of 45 μ C.

For parts whose voltage, U , exceeds 15 kV peak or d.c., the circuit capacitance shall not exceed $700/U^2$ nF, where U is expressed in kilovolts.

NOTE 2 – The limit of $700/U^2$ corresponds to an available energy of 350 mJ.

2.4.3 Connection of limited current circuits to other circuits

LIMITED CURRENT CIRCUITS are permitted to be supplied from or connected to other circuits, provided that the following conditions are met:

- the LIMITED CURRENT CIRCUIT meets the limits of 2.4.2 under normal operating conditions;
- the LIMITED CURRENT CIRCUIT continues to meet the limits of 2.4.2 in the event of a single failure of any component or insulation in the LIMITED CURRENT CIRCUIT, or of any component or insulation in the other circuit to which it is connected.

If a LIMITED CURRENT CIRCUIT is connected to one or more other circuits, the LIMITED CURRENT CIRCUIT is that part which complies with the requirements of 2.4.1.

2.5 Limited power sources

P
NAE

A limited power source operated from an AC MAINS SUPPLY, or a battery-operated limited power source that is recharged from an AC MAINS SUPPLY while supplying the load, shall incorporate an isolating transformer.

A limited power source shall comply with one of the following:

- the output is inherently limited in compliance with table 2B; or
- an impedance limits the output in compliance with table 2B. If a positive temperature coefficient device is used, it shall pass the tests specified in IEC 60730-1, clauses 15, 17, J15 and J17; or
- an overcurrent protective device is used and the output is limited in compliance with table 2C; or
- a regulating network limits the output in compliance with table 2B, both under normal operating conditions and after any single fault (see 1.4.14) in the regulating network (open circuit or short-circuit); or
- a regulating network limits the output in compliance with table 2B under normal operating conditions, and an overcurrent protective device limits the output in compliance with table 2C after any single fault (see 1.4.14) in the regulating network (open-circuit or short-circuit).

Where an overcurrent protective device is used, it shall be a fuse or a non-adjustable non-autoreset electromechanical device.

Compliance is checked by inspection and measurement and, where appropriate, by examination of the manufacturer's data for batteries. Batteries are to be fully charged when conducting the measurements for U_{oc} and I_{sc} according to tables 2B and 2C.

The load referenced in items 2) and 3) of tables 2B and 2C is adjusted to develop maximum current and power transfer respectively. Single faults in a regulating network are applied under these maximum current and power conditions.

Table 2B – Limits for inherently limited power sources

Output voltage ¹⁾ (U_{OC})		Output current ²⁾ (I_{SC}) A	Apparent power ³⁾ (S) (VA)
V a.c.	V d.c.		
≤ 20	≤ 20	$\leq 8,0$	$\leq 5 \times U_{OC}$
$20 < U_{OC} \leq 30$	$20 < U_{OC} \leq 30$	$\leq 8,0$	≤ 100
–	$30 < U_{OC} \leq 60$	$\leq 150 / U_{OC}$	≤ 100

1) U_{OC} : Output voltage measured in accordance with 1.4.5 with all load circuits disconnected. Voltages are for substantially sinusoidal a.c. and ripple-free d.c. For non-sinusoidal a.c. and d.c. with ripple greater than 10 % of the peak, the peak voltage shall not exceed 42,4 V.

2) I_{SC} : Maximum output current with any non-capacitive load, including a short circuit, measured 60 s after application of the load.

3) S (VA): Maximum output VA after 60 s of operation with any non-capacitive load including short circuit. ~~Initial transients lasting less than 100 ms are permitted to exceed the limit.~~

D3
D3**Table 2C – Limits for power sources not inherently limited
(overcurrent protective device required)**

Output voltage ¹⁾ (U_{OC})		Output current ²⁾ (I_{SC}) A	Apparent power ³⁾ (S) VA	Current rating of overcurrent protective device ⁴⁾ A
V a.c.	V d.c.			
≤ 20	≤ 20	$\leq 1\,000 / U_{OC}$	≤ 250	$\leq 5,0$
$20 < U_{OC} \leq 30$	$20 < U_{OC} \leq 30$			$\leq 100 / U_{OC}$
–	$30 < U_{OC} \leq 60$			$\leq 100 / U_{OC}$

1) U_{OC} : Output voltage measured in accordance with 1.4.5 with all load circuits disconnected. Voltages are for substantially sinusoidal a.c. and ripple-free d.c. For non-sinusoidal a.c. and d.c. with ripple greater than 10 % of the peak, the peak voltage shall not exceed 42,4 V.

2) I_{SC} : Maximum output current with any non-capacitive load, including a short circuit, measured 60 s after application of the load. Current limiting impedances in the equipment remain in the circuit during measurement, but overcurrent protective devices are bypassed.

3) S (VA): Maximum output VA after 60 s of operation with any non-capacitive load including short circuit. Current limiting impedances in equipment remain in the circuit during measurement, but overcurrent protective devices are bypassed. ~~Initial transients lasting less than 100 ms are permitted to exceed the limit.~~

NOTE – The reason for making measurements with overcurrent protective devices bypassed is to determine the amount of energy that is available to cause possible overheating during the operating time of the overcurrent protective devices.

4) The current ratings of overcurrent protective devices are based on fuses and circuit breakers that break the circuit within 120 s with a current equal to 210 % of the current rating specified in the table.

D3
D3

2.6 Provisions for earthing and bonding

NAE

NOTE – For additional requirements with regard to earthing of equipment to be connected to TELECOMMUNICATION NETWORKS, see 2.3.2, 2.3.3, 6.1.1 and 6.1.2.

2.6.1 Protective earthing

NAE

The following parts of equipment shall be reliably connected to the main protective earthing terminal of the equipment.

Parts likely to carry fault currents intended to operate overcurrent protective devices:

- a) accessible conductive parts that might assume a HAZARDOUS VOLTAGE in the event of a single fault (see 1.4.14);
- b) parts required to be earthed to maintain the integrity of SELV CIRCUITS, if required by 2.2.3.2 and 2.2.3.3;
- c) parts required to be earthed to maintain the integrity of TNV CIRCUITS, if required by 2.3.3 b);
- d) SELV CIRCUITS, TNV CIRCUITS and accessible conductive parts required to be earthed by 2.3.2, if the power source is not a TELECOMMUNICATION NETWORK.

Parts that carry other currents:

- e) SELV CIRCUITS, TNV CIRCUITS and accessible conductive parts required to be earthed by 2.3.2, if the power source is a TELECOMMUNICATION NETWORK;
- f) transformer screens and components (such as surge suppressors) that could not assume a HAZARDOUS VOLTAGE in the event of a single fault (see 1.4.14) but are required to be earthed in order to reduce transients that might affect insulation (e.g. see 6.2.1);
- g) SELV CIRCUITS and TNV CIRCUITS that are required to be earthed in order to reduce or eliminate TOUCH CURRENT to a TELECOMMUNICATION NETWORK (see 5.1.8.1).

In SERVICE ACCESS AREAS, where conductive parts such as motor frames, electronic chassis, etc., might assume a HAZARDOUS VOLTAGE in the event of a single fault (see 1.4.14), either these conductive parts shall be connected to the main protective earthing terminal or, if this is impossible or impracticable, a suitable marking shall indicate to SERVICE PERSONNEL that such parts are not earthed and should be checked for HAZARDOUS VOLTAGE before being touched.

NOTE – The requirements of 2.6.1 do not apply to accessible conductive parts that are separated from parts at HAZARDOUS VOLTAGE by either:

- earthed metal parts; or
- solid insulation or an air gap, or a combination of the two, meeting the requirements for DOUBLE OR REINFORCED INSULATION, provided that the parts involved are so fixed and so rigid that minimum distances are maintained during the application of force as required by the relevant tests of 4.2.2, 4.2.3 and 4.2.4.

Compliance is checked by inspection and, where appropriate, by the test specified in 2.6.3.

2.6.2 Functional earthing

If FUNCTIONAL EARTHING of accessible or other conductive parts is necessary, all of the following apply to the FUNCTIONAL EARTHING circuit:

- the FUNCTIONAL EARTHING circuit shall be separated from parts at HAZARDOUS VOLTAGES in the equipment by either:
 - DOUBLE OR REINFORCED INSULATION; OR
 - a protectively earthed screen or another protectively earthed conductive part, separated from parts at HAZARDOUS VOLTAGES by at least BASIC INSULATION; and
- it is permitted to connect the FUNCTIONAL EARTHING circuit to a protective earth terminal or to a PROTECTIVE BONDING CONDUCTOR; and
- wiring terminals to be used only for FUNCTIONAL EARTHING shall not be marked by the symbol \perp (60417-1-IEC-5017) or by the symbol \oplus (60417-1-IEC-5019), except that, where a wiring terminal is provided on a component (e.g. a terminal block) or subassembly, the symbol \perp is permitted; and

NOTE – Other markings such as one of the symbols, \perp (60417-1-IEC-5018) or \perp (60417-1-IEC-5020), if appropriate, are permitted.

- for internal FUNCTIONAL EARTHING conductors, the colour combination green-and-yellow shall not be used except in multipurpose preassembled components (e.g. multi-conductor cables or EMC filters); and
- in a power supply cord where a conductor having green-and-yellow insulation is used only to provide a FUNCTIONAL EARTHING connection;
 - the equipment shall not be marked with the symbol \square (60417-1-IEC-5172); and
 - there are no requirements other than those in 3.1.9 regarding the termination of this conductor at the equipment end.

Compliance is checked by inspection.

2.6.3 Protective earthing and protective bonding conductors

NAE

The requirements of 2.6.3.1, 2.6.3.2 and 2.6.3.3 apply to PROTECTIVE EARTHING CONDUCTORS and PROTECTIVE BONDING CONDUCTORS provided to comply with 2.6.1 a), b), c) and d).

For PROTECTIVE EARTHING CONDUCTORS and PROTECTIVE BONDING CONDUCTORS provided to comply with 2.6.1 e), the requirements of 2.6.3.3 apply. The test current is 1,5 times the maximum current available from the TELECOMMUNICATION NETWORK (if known) or 2 A, whichever is the larger.

For PROTECTIVE EARTHING CONDUCTORS and PROTECTIVE BONDING CONDUCTORS provided to comply with 2.6.1 f), 2.6.1 g) and for FUNCTIONAL EARTHING conductors, the current carrying capacity shall be adequate for the actual current under normal operating conditions, in accordance with 3.1.1, i.e. they are not required to carry fault currents to earth.

2.6.3.1 Size of protective earthing conductors

PROTECTIVE EARTHING CONDUCTORS in power supply cords supplied with the equipment, shall comply with the minimum conductor sizes in table 3B (see 3.2.5).

Compliance is checked by inspection and measurement.

2.6.3.2 Size of protective bonding conductors

NAE

PROTECTIVE BONDING CONDUCTORS shall comply with one of the following:

- the minimum conductor sizes in table 3B (see 3.2.5); or
- the requirements of 2.6.3.3 and also, if the current rating of the circuit is more than 16 A, with the minimum conductor sizes in table 2D; or
- for components only, be not smaller than the conductors supplying power to the component.

The current rating of the circuit used in table 2D and in the test of 2.6.3.3 depends on the provision and location of overcurrent protective devices and shall be taken as the smallest of the following:

- the RATED CURRENT of the equipment; or
- the rating of an overcurrent protective device specified in the equipment installation instructions to be installed in the building installation wiring to protect the equipment; or
- the rating of an overcurrent protective device in the equipment that protects the circuit or part required to be earthed.

Compliance is checked by inspection and measurement.

Table 2D – Minimum size of protective bonding conductors

Current rating of the circuit under consideration A	Minimum conductor sizes	
	Cross-sectional area mm ²	AWG or kcmil (cross-sectional area in mm ²)
Up to and including 16	Size not specified	Size not specified
Over 16 up to and including 25	1,5	14 (2)
Over 25 up to and including 32	2,5	12 (3)
Over 32 up to and including 40	4,0	10 (5)
Over 40 up to and including 63	6,0	8 (8)
Over 63 up to and including 80	10	6 (13)
Over 80 up to and including 100	16	4 (21)
Over 100 up to and including 125	25	2 (33)
Over 125 up to and including 160	35	1 (42)
Over 160 up to and including 190	50	0 (53)
Over 190 up to and including 230	70	000 (85)
Over 230 up to and including 260	95	0000 (107)
Over 260 up to and including 300	120	250 kcmil (126)
Over 300 up to and including 340	150	300 kcmil (152)
Over 340 up to and including 400	185	400 kcmil (202)
Over 400 up to and including 460	240	500 kcmil (253)

NOTE – AWG and kcmil sizes are provided for information only. The associated cross-sectional areas have been rounded to show significant figures only. AWG refers to the American Wire Gage and the term “cmil” refers to circular mils where one circular mil is equal to the area of a circle having a diameter of one mil (one thousandth of an inch). These terms are commonly used to designate wire sizes in North America.

2.6.3.3 Resistance of earthing conductors and their terminations

Earthing conductors and their terminations shall not have excessive resistance.

PROTECTIVE EARTHING CONDUCTORS are considered to comply without test.

PROTECTIVE BONDING CONDUCTORS that meet the minimum conductor sizes in table 3B (see 3.2.5) and are terminated in accordance with table 3E (see 3.3.5) are considered to comply without test.

PROTECTIVE BONDING CONDUCTORS and their terminals of non-standard constructions, such as printed wiring protective traces, shall also be evaluated in accordance with the Limited Short-Circuit Test in CSA C22.2 No. 0.4, Bonding and Grounding of Electrical Equipment. PROTECTIVE BONDING CONDUCTORS that can be determined to meet the equivalent of the minimum conductor sizes in table 3B (see 3.2.5) and are terminated in accordance with table 3E (see 3.3.5) are considered to comply without test.

D1
D1
D1
D1
D1
D1

NOTE – Short circuit values for d.c. equipment and systems are under consideration.

D1

Compliance is checked by inspection, measurement and, for PROTECTIVE BONDING CONDUCTORS that do not comply with the minimum sizes in table 3B (see 3.2.5) and for protective bonding terminals that do not comply with table 3E (see 3.3.5), by the following test.

The voltage drop in a PROTECTIVE BONDING CONDUCTOR is measured after it has conducted the test current for a time period specified below. The test current can be either a.c. or d.c. The measurement is made between the main protective earthing terminal and the point in the equipment that is required by 2.6.1 to be earthed. The resistance of the PROTECTIVE EARTHING

CONDUCTOR is not included in the measurement. However, if the PROTECTIVE EARTHING CONDUCTOR is supplied with the equipment, it is permitted to include it in the test circuit but the measurement of the voltage drop is made only from the main protective earthing terminal to the part required to be earthed.

On equipment where the protective earth connection to a subassembly or to a separate unit is by means of one core of a multicore cable which also supplies mains power to that subassembly or unit, the resistance of the PROTECTIVE BONDING CONDUCTOR in that cable is not included in the measurement. However, this option is only permitted if the cable is protected by a suitably rated protective device which takes into account the size of the conductor.

If the protection of an SELV CIRCUIT is achieved by earthing in accordance with 2.2.3.3, the resistance limit applies between the earthed side of the SELV CIRCUIT and the main protective earthing terminal and not from the unearthed side of the SELV CIRCUIT.

Care is taken that the contact resistance between the tip of the measuring probe and the conductive part under test does not influence the test results.

If the current rating of the circuit under test is 16 A or less, the test current, test voltage and the duration of the test are determined as follows:

- the test current is 1,5 two times the current rating of the circuit under test; and D1
- the test voltage is not to exceed 12 V; and
- the duration of the test is 60 120 s; D1

and the resistance of the PROTECTIVE BONDING CONDUCTOR, calculated from the voltage drop, shall not exceed 0,1 Ω .

If the current rating of the circuit under test exceeds 16 A, the test current and the duration of the test are as follows: two times the current rating of the circuit for 2 min; or the time durations noted below: D2
D2

<u>Current rating of circuit, A</u>	<u>Time, minutes</u>	<u>D1</u>
≤ 30	<u>2</u>	D1
$> 30, \leq 60$	<u>4</u>	D1
$> 60, \leq 100$	<u>6</u>	D1
$> 100, \leq 200$	<u>8</u>	D1
> 200	<u>10</u>	D1

- or as specified by the manufacturer for d.c. powered equipment DE

and the voltage drop across the PROTECTIVE BONDING CONDUCTOR shall not exceed 2,5 V.

2.6.3.4 Colour of insulation

The insulation of the PROTECTIVE EARTHING CONDUCTOR in a power supply cord supplied with the equipment shall be green-and-yellow.

If a PROTECTIVE BONDING CONDUCTOR is insulated, the insulation shall be green-and-yellow except in the following two cases:

- for an earthing braid, the insulation shall be either green-and-yellow or transparent;
- for a PROTECTIVE BONDING CONDUCTOR in assemblies such as ribbon cables, busbars, printed wiring, etc., any colour is permitted provided that no misinterpretation of the use of the conductor is likely to arise.

Except as permitted in 2.6.2, the colour combination green-and-yellow shall be used only to identify PROTECTIVE EARTHING CONDUCTORS and PROTECTIVE BONDING CONDUCTORS.

Compliance is checked by inspection.

2.6.4 Terminals

NAE

The requirements of 2.6.4.1 and 2.6.4.2 apply only to protective earthing terminals provided to comply with 2.6.1 a), b), c) and d).

NOTE – For additional requirements concerning terminals, see 3.3.

For protective earthing provided to comply with 2.6.1 e), f) and g), it is sufficient for the terminals to comply with 3.3.

2.6.4.1 Protective earthing and bonding terminals

NAE

Equipment required to have protective earthing shall have a main protective earthing terminal. For equipment with a DETACHABLE POWER SUPPLY CORD, the earthing terminal in the appliance inlet is regarded as the main protective earthing terminal.

If equipment is provided with more than one supply connection (e.g. with different voltages or frequencies or as backup power), it is permitted to have a main protective earthing terminal associated with each supply connection. In such a case, the terminals shall be sized according to the rating of the associated supply input.

Terminals shall be designed to resist accidental loosening of the conductor. In general, the designs commonly used for current-carrying terminals, other than some terminals of the pillar type, provide sufficient resilience to comply with this requirement; for other designs, special provisions, such as the use of an adequately resilient part which is not likely to be removed inadvertently, shall be used.

Except as noted below, all pillar, stud or screw type protective earthing and protective bonding terminals shall comply with the minimum size requirements of table 3E (see 3.3.5).

Protective bonding terminals which do not comply with table 3E (see 3.3.5) are considered acceptable if they meet the test requirements of 2.6.3.3.

The main protective earthing terminal for PERMANENTLY CONNECTED EQUIPMENT shall be:

- located so that it is readily accessible while making the supply connections; and
- provided with factory installed pillar terminals, studs, screws, bolts or similar terminals, together with the necessary fixing hardware, if a PROTECTIVE EARTHING CONDUCTOR larger than 7 mm² (3 mm diameter) is required.

Compliance is checked by inspection and measurement.

2.6.4.2 Separation of the protective earthing conductor from protective bonding conductors

Separate wiring terminals, which may be on the same busbar, shall be provided, one for the PROTECTIVE EARTHING CONDUCTOR, or one for each PROTECTIVE EARTHING CONDUCTOR if more than one is provided, and one or more for PROTECTIVE BONDING CONDUCTORS.

However, it is permitted to provide a single wiring terminal of the screw or stud type in PERMANENTLY CONNECTED EQUIPMENT having a NON-DETACHABLE POWER SUPPLY CORD, and in PLUGGABLE EQUIPMENT TYPE A OR B having a special NON-DETACHABLE POWER SUPPLY CORD, provided that the wiring termination of the PROTECTIVE EARTHING CONDUCTOR is separated by a nut from that of the PROTECTIVE BONDING CONDUCTORS. The order of stacking of the terminations of the PROTECTIVE EARTHING CONDUCTOR and the PROTECTIVE BONDING CONDUCTORS is not specified.

It is also permitted to provide a single wiring terminal in equipment with an appliance inlet.

Compliance is checked by inspection.

2.6.5 Integrity of protective earthing

2.6.5.1 Interconnection of equipment

NAD

In a system of interconnected equipment, the protective earthing connection shall be assured for all equipment requiring a protective earthing connection, regardless of the arrangement of equipment in the system.

Equipment that contains a PROTECTIVE BONDING CONDUCTOR to maintain continuity of protective earthing circuits to other equipment in the system, shall not be marked with the symbol □ (60417-2-IEC-5172).

Such equipment shall also provide power to the other equipment in the system (see 2.6.5.3).

Compliance is checked by inspection.

2.6.5.2 Components in protective earthing conductors and protective bonding conductors

PROTECTIVE EARTHING CONDUCTORS and PROTECTIVE BONDING CONDUCTORS shall not contain switches or overcurrent protective devices.

Compliance is checked by inspection.

2.6.5.3 Disconnection of protective earth

Protective earthing connections shall be such that disconnection of a protective earth at one point in a unit or a system does not break the protective earthing connection to other parts or units in a system, unless the relevant potential hazard is removed at the same time.

Compliance is checked by inspection.

2.6.5.4 Parts that can be removed by an operator

Protective earthing connections shall make earlier and break later than the supply connections in each of the following:

- the connector of a part that can be removed by an OPERATOR;
- a plug on a power supply cord;
- an appliance coupler.

Compliance is checked by inspection.

2.6.5.5 Parts removed during servicing

Protective earthing connections shall be so designed that they do not have to be disconnected for servicing other than for the removal of the part which they protect unless the relevant potential hazard is removed at the same time.

Compliance is checked by inspection.

2.6.5.6 Corrosion resistance

J

Conductive parts in contact at protective earthing terminals and connections shall not be subject to significant corrosion due to electrochemical action in any working, storage or transport environment conditions as specified in the instructions supplied with the equipment. Combinations above the line in annex J shall be avoided. Corrosion resistance can be achieved by a suitable plating or coating process.

Compliance is checked by inspection and by reference to the table of electrochemical potentials (annex J).

2.6.5.7 Screws for protective bonding

NOTE –The following requirements are additional to those in 3.1.6.

Self-tapping (thread-cutting and thread-forming) and spaced thread (sheet metal) screws are permitted to provide protective bonding but it shall not be necessary to disturb the connection during servicing.

In any case, the thickness of the metal part at the point where a screw is threaded into it shall be not less than twice the pitch of the screw thread. It is permitted to use local extrusion of a metal part to increase the effective thickness.

At least two screws shall be used for each connection. However, it is permitted to use a single self-tapping screw provided that the thickness of the metal part at the point where the screw is threaded into it is a minimum of 0,9 mm for a screw of the thread-forming type and 1,6 mm for a screw of the thread-cutting type.

Compliance is checked by inspection.

2.6.5.8 Reliance on telecommunication network

Protective earthing shall not rely on a TELECOMMUNICATION NETWORK.

Compliance is checked by inspection.

2.7 Overcurrent and earth fault protection in primary circuits

P

2.7.1 Basic requirements

**NAA
NAE**

Protection in PRIMARY CIRCUITS against overcurrents, short-circuits and earth faults shall be provided, either as an integral part of the equipment or as part of the building installation.

If PLUGGABLE EQUIPMENT TYPE B OR PERMANENTLY CONNECTED EQUIPMENT relies on protective devices in the building installation for protection, the equipment installation instructions shall so state and shall also specify the requirements for short-circuit protection or overcurrent protection or, where necessary, for both.

NOTE – In the member countries of CENELEC, the protective devices necessary to comply with the requirements of 5.3 must, with certain exceptions, be included as part of the equipment.

2.7.2 Faults not covered in 5.3

Protection against faults not covered in 5.3 (e.g. short-circuits to protective earth in primary wiring) need not be fitted as an integral part of the equipment.

Compliance is checked by inspection.

2.7.3 Short-circuit backup protection

Unless appropriate short-circuit backup protection is provided, protective devices shall have adequate breaking (rupturing) capacity to interrupt the maximum fault current (including short-circuit current) which can flow.

For PERMANENTLY CONNECTED EQUIPMENT OR PLUGGABLE EQUIPMENT TYPE B, it is permitted for short-circuit backup protection to be in the building installation.

For PLUGGABLE EQUIPMENT TYPE A, the building installation is considered as providing short-circuit backup protection.

NOTE – If fuses complying with IEC 60127 are used in PRIMARY CIRCUITS, they should have high breaking capacity (1 500 A) if the prospective short-circuit current exceeds 35 A or 10 times the current rating of the fuse, whichever is greater.

Compliance is checked by inspection and by the tests of 5.3.

2.7.4 Number and location of protective devices

Protective systems or devices in PRIMARY CIRCUITS shall be in such a number and located so as to detect and to interrupt the overcurrent flowing in any possible fault current path (e.g. line-to-line, line-to-neutral, line to protective earth conductor or line to PROTECTIVE BONDING CONDUCTOR).

No protection is required against earth faults in equipment that either:

- has no connection to earth; or
- has DOUBLE OR REINFORCED INSULATION between the PRIMARY CIRCUIT and all parts connected to earth.

NOTE 1 – Where DOUBLE OR REINFORCED INSULATION is provided, a short circuit to earth would be considered to be two faults.

In a supply to a load using more than one line conductor, if a protective device interrupts the neutral conductor it shall also interrupt all other supply conductors. Single-pole protective devices, therefore, shall not be used in such cases.

Compliance is checked by inspection and, where necessary, by simulation of fault conditions.

NOTE 2 – For protective devices that are an integral part of the equipment, examples of the number and location of fuses or circuit-breaker poles necessary to provide fault current interruption in commonly encountered supply systems are given in informative table 2E for single-phase equipment or subassemblies and in informative table 2F for three-phase equipment. The examples are not necessarily valid for protective devices in the building installation.

Table 2E – Informative examples of protective devices in single-phase equipment or subassemblies

Equipment supply connections	Protection against	Minimum number of fuses or circuit-breaker poles	Location
Case A: Equipment to be connected to power systems with earthed neutral reliably identified, except for case C below.	Earth faults	1	Line conductor
	Overcurrent	1	Either of the two conductors
Case B: Equipment to be connected to any supply, including IT power systems and supplies with reversible plugs, except for case C below.	Earth faults	2	Both conductors
	Overcurrent	1	Either of the two conductors
Case C: Equipment to be connected to 3-wire power systems with earthed neutral reliably identified.	Earth faults	2	Each line conductor
	Overcurrent	2	Each line conductor

Table 2F – Informative examples of protective devices in three-phase equipment

Power system	Number of supply conductors	Protection against	Minimum number of fuses or circuit-breaker poles	Location
Three-phase without neutral	3	Earth faults	3	All three conductors
		Overcurrent	2	Any two conductors
With earthed neutral (TN or TT)	4	Earth faults	3	Each line conductor
		Overcurrent	3	Each line conductor
With unearthed neutral	4	Earth faults	4	All four conductors
		Overcurrent	3	Each line conductor

2.7.5 Protection by several devices

Where protective devices are used in more than one pole of a supply to a given load, those devices shall be located together. It is permitted to combine two or more protective devices in one component.

Compliance is checked by inspection.

2.7.6 Warning to service personnel

NAA

Suitable marking shall be provided on the equipment or a statement shall be provided in the servicing instructions to alert SERVICE PERSONNEL to a possible hazard, where both of the following conditions exist:

- where a fuse is used in the neutral of single-phase equipment either permanently connected or provided with a non-reversible plug; and
- where, after operation of the fuse, parts of the equipment that remain energized might represent a hazard during servicing.

The following or similar wording is regarded as suitable:

CAUTION

DOUBLE POLE/NEUTRAL FUSING

2.8 Safety interlocks

2.8.1 General principles

SAFETY INTERLOCKS shall be provided where OPERATOR access involves areas normally presenting hazards in the meaning of this standard.

2.8.2 Protection requirements

SAFETY INTERLOCKS shall be so designed that the hazard will be removed before the covers, doors, etc. are in any position that will permit contact with hazardous parts by the test finger, of figure 2A (see 2.1.1.1).

For protection against electric shock and energy hazards, removal, opening or withdrawal of the cover, door, etc., shall either:

- necessitate previous de-energization of such parts, or
- automatically initiate disconnection of the supply to such parts, and reduce within 2 s the voltage to 42,4 V peak, or 60 V d.c., or less, and the energy level to less than 20 J.

For a moving part which will continue to move through momentum and will continue to present a mechanical hazard (e.g. a spinning print drum), removal, opening or withdrawal of the cover, door, etc., shall either:

- necessitate previous reduction of movement to an acceptably safe level; or
- automatically initiate reduction of the movement to an acceptably safe level.

Compliance is checked by inspection, measurement and use of the test finger, of figure 2A (see 2.1.1.1).

2.8.3 Inadvertent reactivation

SAFETY INTERLOCKS shall be designed so that inadvertent reactivation of the hazard cannot occur when covers, guards, doors, etc., are not in the closed position.

Any accessible interlock which can be operated by means of the test finger, of figure 2A (see 2.1.1.1), is considered to be likely to cause inadvertent reactivation of the hazard.

SAFETY INTERLOCK switches shall be selected taking into account the mechanical shock and vibration experienced in normal operation, so that this does not cause inadvertent switching to an unsafe condition.

Compliance is checked by inspection and, where necessary, by a test with the test finger, of figure 2A (see 2.1.1.1).

2.8.4 Fail-safe operation

P

A SAFETY INTERLOCK system shall be so designed and constructed that either:

- if a failure of the interlock system during the normal life of the equipment is not likely to occur and, even if a failure should occur, it shall not create an extreme hazard; or
- if a failure of the interlock system during the normal life of the equipment is possible, the probable failure mode(s) will not create a hazard for which protection is required.

Compliance is checked by inspection of the interlock system, circuit diagrams and available data and, if necessary, by simulation of single faults (see 1.4.14), for example, failure of a semi-conductor device or an electromechanical component. Moving mechanical parts in mechanical and electromechanical systems are not subjected to simulated single faults if they comply with 2.8.5 and 2.8.7.

It is permitted to use simulated interlock systems for tests.

2.8.5 Interlocks with moving parts

Moving mechanical parts in mechanical and electromechanical interlock systems shall have adequate endurance.

Compliance is checked by inspection of the interlock system, available data and, if necessary, by cycling the interlock system through 10 000 operations without failure other than in a safe mode.

NOTE – The above test is carried out to check the endurance of moving parts other than those in interlock switches and relays. Interlock switches and relays, if any, are subject to 2.8.7. If the test of 2.8.7.3 is required in addition to the above test, the tests should be combined.

2.8.6 Overriding an interlock

Where it may be necessary for SERVICE PERSONNEL to override a SAFETY INTERLOCK, the override system shall comply with all of the following:

- require an intentional effort to operate; and
- reset automatically to normal operation when servicing is complete, or prevent normal operation unless the SERVICE PERSONNEL have carried out restoration; and
- require a TOOL for operation when in OPERATOR ACCESS AREA and not be operable with the test finger, of figure 2A (see 2.1.1.1); and
- not bypass a SAFETY INTERLOCK for an extreme hazard unless another reliable means of safety protection becomes effective when the interlock is thus bypassed. The equipment shall be designed such that the interlock cannot be bypassed until the other means of protection is fully in place and operational.

Compliance is checked by inspection.

2.8.7 Switches and relays in interlock systems

P

A switch in an interlock system shall:

- for switches, conform with IEC 61058-1, with evaluation for 10 000 operating cycles in accordance with IEC 61058-1, 7.1.4.4; or
- comply with 2.8.7.1 and pass the tests of 2.8.7.3 and 2.8.7.4; or
- pass the tests of 2.8.7.2, 2.8.7.3 and 2.8.7.4.

A relay in an interlock system shall:

- comply with 2.8.7.1 and pass the tests of 2.8.7.3 and 2.8.7.4; or
- pass the tests of 2.8.7.2, 2.8.7.3 and 2.8.7.4.

2.8.7.1 Contact gaps

If the contact gap is located in the PRIMARY CIRCUIT, the contact gap shall not be less than that for a disconnect device (see 3.4.2). If the contact gap is located in a circuit other than a PRIMARY CIRCUIT, the contact gap shall not be less than the relevant minimum CLEARANCE value in 2.10.3.3 for BASIC INSULATION in a SECONDARY CIRCUIT.

Compliance is checked by inspection of the available data and, if by necessary, measurement.

2.8.7.2 Overload test

The contact of the interlock switch or relay is subjected to an overload test consisting of 50 cycles of operation at the rate of 6 to 10 cycles per minute, making and breaking 150 % of the current imposed in the application, except that where a contact switches a motor load, the test is conducted with the rotor of the motor in a locked condition. After the test, the switch or relay shall still be functional.

2.8.7.3 Endurance test

The contact of the interlock switch or relay is subjected to an endurance test, making and breaking 100 % of the current imposed in the application at a rate of 6 to 10 cycles of operation per minute. A higher rate of cycling is permitted if requested by the manufacturer. For reed switches in ELV CIRCUITS, SELV CIRCUITS and TNV-1 CIRCUITS, the test is 100 000 cycling operations. For other switches and relays, the test is 10 000 cycling operations. After the test, the switch or relay shall still be functional.

2.8.7.4 Electric strength test

Except for reed switches in ELV CIRCUITS, SELV CIRCUITS and TNV-1 CIRCUITS, an electric strength test as specified in 5.2.2, is applied between the contacts after the tests of 2.8.7.2 and 2.8.7.3. If the contact is in a PRIMARY CIRCUIT, the test voltage is as specified for REINFORCED INSULATION. If the contact is in a circuit other than a PRIMARY CIRCUIT, the test voltage is as specified for BASIC INSULATION in a PRIMARY CIRCUIT.

2.8.8 Mechanical actuators

Where the actuating part in a mechanical interlock system is relied upon for safety, precautions shall be taken to ensure that it is not overstressed. If this requirement is not covered by the design of the component, the over-travel beyond the operating position of the actuator shall be limited to 50 % of the maximum, for example by its mounting or location, or by adjustment.

Compliance is checked by inspection and measurement.

2.9 Electrical insulation

2.9.1 Properties of insulating materials

P

The choice and application of insulating materials shall take into account the needs for electrical, thermal and mechanical strength, frequency of the WORKING VOLTAGE and the working environment (temperature, pressure, humidity and pollution).

Natural rubber, hygroscopic materials and materials containing asbestos shall not be used as insulation.

Driving belts and couplings shall not be relied upon to ensure electrical insulation, unless the belt or coupling is of a special design which removes the risk of inappropriate replacement.

Compliance is checked by inspection and, where necessary, by evaluation of the data for the material.

Where necessary, if the data does not confirm that the material is non-hygroscopic, the hygroscopic nature of the material is determined by subjecting the component or subassembly employing the insulation in question to the humidity treatment of 2.9.2. The insulation is then subjected to the relevant electric strength test of 5.2.2 while still in the humidity cabinet, or in the room in which the samples were brought to the prescribed temperature.

2.9.2 Humidity conditioning

Where required by 2.9.1, 2.10.6.5 or 2.10.7, humidity conditioning is carried out for 48 h in a cabinet or room containing air with a relative humidity of 91 % to 95 %. The temperature of the air, at all places where samples can be located, is maintained within 1 °C of any convenient value t between 20 °C and 30 °C such that condensation does not occur. During this conditioning the component or subassembly is not energized.

With the concurrence of the manufacturer, it is permitted to increase the 48 h time duration.

Before the humidity conditioning the sample is brought to a temperature between t and $t + 4$ °C.

2.9.3 Requirements for insulation

Insulation in equipment shall comply with the heating requirements of 4.5.1 and, except where 2.1.1.3 or 2.1.1.4 applies, with both of the following

- the applicable electric strength requirements of 5.2; and
- the requirements for CLEARANCE, CREEPAGE DISTANCE and solid insulation of 2.10.

2.9.4 Insulation parameters

For the purpose of determining the test voltages, minimum CLEARANCES, minimum CREEPAGE DISTANCES, solid insulation criteria and other requirements for a given piece of insulation, two parameters shall be considered:

- application of insulation (see 2.9.5); and
- WORKING VOLTAGE (see 2.10.2 and 5.2).

2.9.5 Categories of insulation

P

Insulation shall be considered to be FUNCTIONAL, BASIC, SUPPLEMENTARY, REINFORCED OR DOUBLE INSULATION.

The application of insulation in many common situations is described in table 2G and illustrated in figure 2F, but other situations and solutions are possible. These examples are informative; in some cases the necessary grade of insulation may be higher or lower. Where a different grade may be necessary, or if a particular configuration of energized parts is not represented in the examples, the necessary grade of insulation should be determined by considering the effect of a single fault (see 1.4.14). This should leave the requirements for protection against electric shock intact.

In certain cases, insulation may be bridged by a conductive path (e.g., where 1.5.7, 2.2.4, 2.3.4 or 2.4.3 applies) provided that the level of safety is maintained.

For DOUBLE INSULATION it is permitted to interchange the BASIC and SUPPLEMENTARY INSULATION elements. Where DOUBLE INSULATION is used, ELV CIRCUITS or unearthed conductive parts are permitted between the BASIC INSULATION and the SUPPLEMENTARY INSULATION provided that the overall level of insulation is maintained.

Table 2G – Examples of application of insulation

Grade of insulation	Location of Insulation		Key to figure 2F
	between	and	
1. FUNCTIONAL see 1)	unearthed SELV CIRCUIT or double-insulated conductive part	– earthed conductive part	F1
		– double-insulated conductive part	F2
		– unearthed SELV CIRCUIT	F2
		– earthed SELV CIRCUIT	F1
		– earthed TNV-1 CIRCUIT	F10 see 6)
	earthed SELV CIRCUIT	– earthed SELV CIRCUIT	F11
		– earthed conductive part	F11
		– unearthed TNV-1 CIRCUIT	F12 see 6)
	– earthed TNV-1 CIRCUIT	F13 see 6)	
ELV CIRCUIT or basic- insulated conductive part	– earthed conductive part	F3	
	– earthed SELV CIRCUIT	F3	
	– basic-insulated conductive part	F4	
	– ELV CIRCUIT	F4	
earthed HAZARDOUS VOLTAGE SECONDARY CIRCUIT	earthed HAZARDOUS VOLTAGE SECONDARY CIRCUIT	F5	
TNV-1 CIRCUIT	TNV-1 CIRCUIT	F7	
TNV-2 CIRCUIT	TNV-2 CIRCUIT	F8	
TNV-3 CIRCUIT	TNV-3 CIRCUIT	F9	
series-parallel sections of a transformer winding		F6	

Table 2G – Examples of application of insulation Continued

Grade of insulation	Location of Insulation		Key to figure 2F
	between	and	
2. BASIC	PRIMARY CIRCUIT	– earthed or unearthed HAZARDOUS VOLTAGE SECONDARY CIRCUIT – earthed conductive part – earthed SELV CIRCUIT – basic-insulated conductive part – ELV CIRCUIT	B1 B2 B2 B3 B3
	earthed or unearthed HAZARDOUS VOLTAGE SECONDARY CIRCUIT	– unearthed HAZARDOUS VOLTAGE SECONDARY CIRCUIT – earthed conductive part – earthed SELV CIRCUIT – basic-insulated conductive part – ELV CIRCUIT	B4 B5 B5 B6 B6
	unearthed SELV CIRCUIT or double-insulated conductive part	– unearthed TNV-1 CIRCUIT – TNV-2 CIRCUIT – TNV-3 CIRCUIT	B7 see 6) B8 B9 see 5)
	earthed SELV CIRCUIT	– TNV-2 CIRCUIT – TNV-3 CIRCUIT	B10 see 4) B10 see 4) 5)
	TNV-2 CIRCUIT	– unearthed TNV-1 CIRCUIT – earthed TNV-1 CIRCUIT – TNV-3 CIRCUIT	B12 see 5) B13 see 4) 5) B14 see 6)
	TNV-3 CIRCUIT	– unearthed TNV-1 CIRCUIT – earthed TNV-1 CIRCUIT	B12 B13 see 4)
	3. SUPPLEMENTARY	basic-insulated conductive part or ELV CIRCUIT	– double-insulated conductive part – unearthed SELV CIRCUIT
TNV CIRCUIT		– basic-insulated conductive part – ELV CIRCUIT	S2 see 4) S2
4. SUPPLEMENTARY or REINFORCED	unearthed HAZARDOUS VOLTAGE SECONDARY CIRCUIT	– double-insulated conductive part – unearthed SELV CIRCUIT – TNV CIRCUIT	S/R1 see 3) S/R1 see 3) S/R2 see 3)
5. REINFORCED	PRIMARY CIRCUIT	– double-insulated conductive part – unearthed SELV CIRCUIT – TNV CIRCUIT	R1 R1 R2
	earthed HAZARDOUS VOLTAGE SECONDARY CIRCUIT	– double-insulated conductive part – unearthed SELV CIRCUIT – TNV CIRCUIT	R3 R3 R4
<p>1) See 5.3.4 for requirements for FUNCTIONAL INSULATION.</p> <p>2) The working voltage of the SUPPLEMENTARY INSULATION between an ELV CIRCUIT or a basic-insulated conductive part and an unearthed accessible conductive part is equal to the most onerous WORKING VOLTAGE for the BASIC INSULATION. The most onerous WORKING VOLTAGE may be due to a PRIMARY CIRCUIT or SECONDARY CIRCUIT and the insulation is specified accordingly.</p>			

Table 2G – Examples of application of insulation Continued

Grade of insulation	Location of Insulation		Key to figure 2F
	between	and	
<p>3)Insulation between an unearthed SECONDARY CIRCUIT at HAZARDOUS VOLTAGE and an unearthed accessible conductive part or circuit (S/R in figure 2F) shall satisfy the more onerous of the following:</p> <ul style="list-style-type: none"> – REINFORCED INSULATION whose WORKING VOLTAGE is equal to the HAZARDOUS VOLTAGE; or – SUPPLEMENTARY INSULATION whose WORKING VOLTAGE is equal to the voltage between: <ul style="list-style-type: none"> • the SECONDARY CIRCUIT at HAZARDOUS VOLTAGE; and • another SECONDARY CIRCUIT at HAZARDOUS VOLTAGE or a PRIMARY CIRCUIT. <p>These examples apply if:</p> <ul style="list-style-type: none"> – there is only BASIC INSULATION between the SECONDARY CIRCUIT and the PRIMARY CIRCUIT; and – there is only BASIC INSULATION between the SECONDARY CIRCUIT and earth. <p>4)BASIC INSULATION is not always required (see 2.3.2.).</p> <p>5)The requirements of 2.10 apply. See also 6.2.1.</p> <p>6)The requirements of 2.10 do not apply, but see 6.2.1.</p>			
<p>NOTE – The term “conductive part” refers to an electrically conductive part that is:</p> <ul style="list-style-type: none"> – not normally energized, and – not connected to any of the following: <ul style="list-style-type: none"> • a circuit at HAZARDOUS VOLTAGE, or • an ELV CIRCUIT, or • a TNV CIRCUIT, or • an SELV CIRCUIT, or • a LIMITED CURRENT CIRCUIT. <p>Examples of such a conductive part are the BODY of equipment, a transformer core, and in some cases a conductive screen in a transformer.</p> <p>If such a conductive part is protected from a part at HAZARDOUS VOLTAGE by:</p> <ul style="list-style-type: none"> – DOUBLE OR REINFORCED INSULATION, it is termed a “double-insulated conductive part”; – BASIC INSULATION plus protective earthing, it is termed an “earthed conductive part”; – BASIC INSULATION but is not earthed, i.e. it has no second level of protection, it is termed a “basic-insulated conductive part”. <p>A circuit or conductive part is termed “earthed” if it is connected to a protective earthing terminal or contact in such a way as to meet the requirements in 2.6 (although it will not necessarily be at earth potential). Otherwise the circuit or conductive part is termed “unearthed”.</p>			

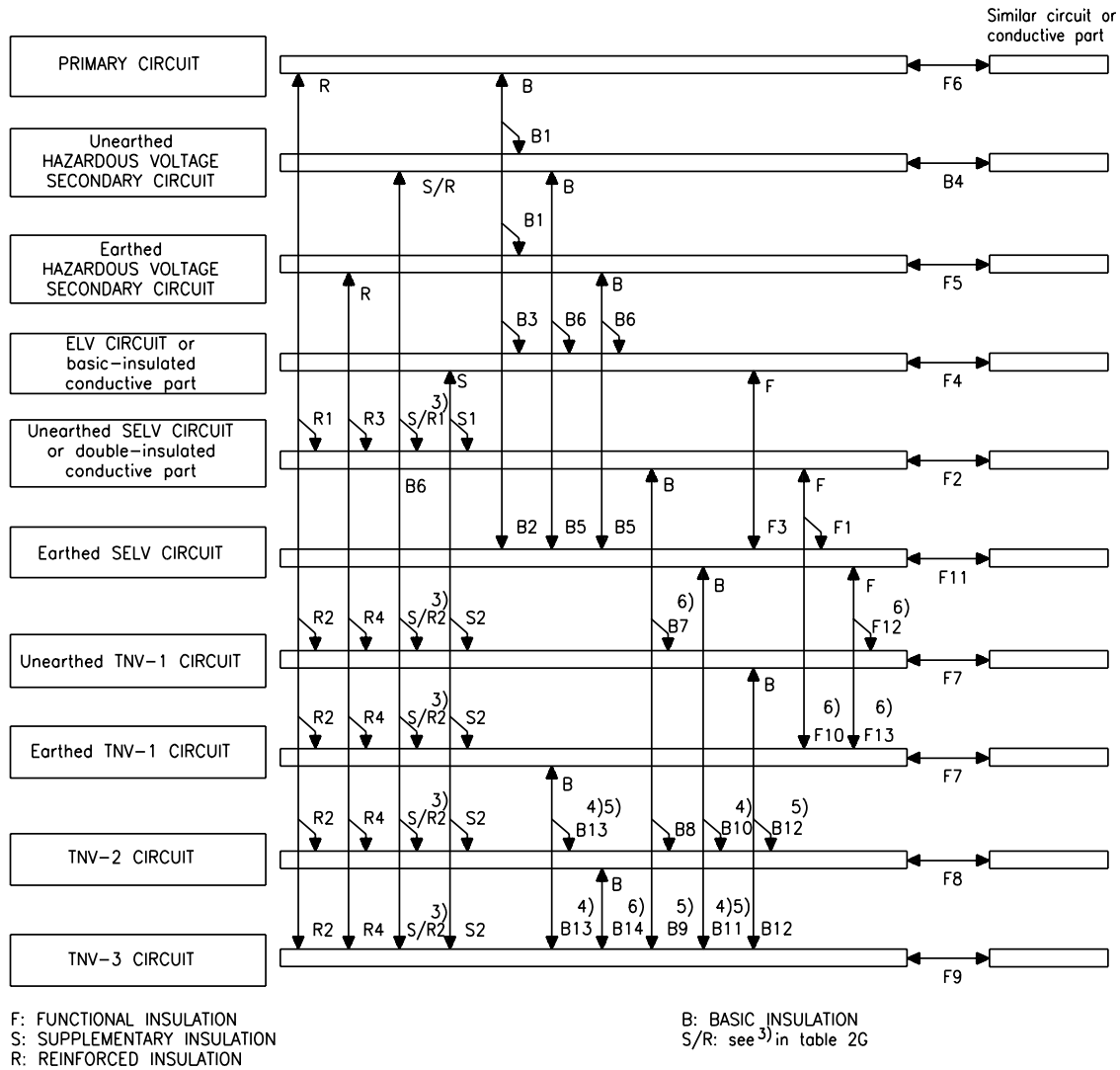

S4299

Figure 2F – Examples of application of insulation

2.10 Clearances, creepage distances and distances through insulation

F

2.10.1 General

CLEARANCES shall be so dimensioned that overvoltage transients which may enter the equipment, and peak voltages which may be generated within the equipment, do not break down the CLEARANCE. Detailed requirements are given in 2.10.3.

CREEPAGE DISTANCES shall be so dimensioned that, for a given WORKING VOLTAGE and Pollution Degree, no flashover or breakdown (tracking) of insulation will occur. Detailed requirements are given in 2.10.4.

The methods of measuring CLEARANCES and CREEPAGE DISTANCES are given in annex F.

Solid insulation shall be:

- so dimensioned that overvoltage transients that enter the equipment and peak voltages that may be generated within the equipment, do not break down the solid insulation; and
- for thin layers of insulation, so arranged that the likelihood of having pinholes aligned is limited.

Detailed requirements are given in 2.10.5.

The insulation requirements given in 2.10 are for frequencies up to 30 kHz. It is permitted to use the same requirements for insulation operating at frequencies over 30 kHz until additional data is available.

NOTE – For information on insulation behaviour in relation to frequency see IEC 60664-1 and IEC 60664-4.

For FUNCTIONAL INSULATION, CLEARANCES and CREEPAGE DISTANCES smaller than those specified in 2.10 are permitted subject to the requirements of 5.3.4 b) or 5.3.4 c).

It is permitted for CLEARANCES and CREEPAGE DISTANCES to be divided by intervening, unconnected (floating) conductive parts, such as unused contacts of a connector, provided that the sum of the individual distances meets the specified minimum requirements (see figure F.13).

The minimum CLEARANCE and CREEPAGE DISTANCE values given for various Pollution Degrees apply as follows:

- Pollution Degree 1 for components and assemblies which are sealed so as to exclude dust and moisture (see 2.10.7).
- Pollution Degree 2 generally for equipment covered by the scope of this standard.
- Pollution Degree 3 where a local internal environment within the equipment is subject to conductive pollution or to dry non-conductive pollution which could become conductive due to expected condensation.

2.10.2 Determination of working voltage

In determining the WORKING VOLTAGES, all of the following requirements apply (see also 1.4.7):

- the value of the RATED VOLTAGE or the upper voltage of the RATED VOLTAGE RANGE shall be:
 - used for WORKING VOLTAGE between a PRIMARY CIRCUIT and earth; and
 - taken into account for determination of the WORKING VOLTAGE between a PRIMARY CIRCUIT and a SECONDARY CIRCUIT; and
- unearthed accessible conductive parts shall be assumed to be earthed; and
- where a transformer winding or other part is floating, i.e. not connected to a circuit which establishes its potential relative to earth, it shall be assumed to be earthed at the point by which the highest WORKING VOLTAGE is obtained; and
- where DOUBLE INSULATION is used, the WORKING VOLTAGE across the BASIC INSULATION shall be determined by imagining a short circuit across the SUPPLEMENTARY INSULATION, and vice versa. For DOUBLE INSULATION between transformer windings, the short circuit shall be assumed to take place at the point by which the highest WORKING VOLTAGE is produced in the other insulation; and
- except as permitted in 2.10.10, for insulation between two transformer windings, the highest voltage between any two points in the two windings shall be used, taking into account external voltages to which the windings will be connected; and
- except as permitted in 2.10.10, for insulation between a transformer winding and another part, the highest voltage between any point on the winding and the other part shall be used.

2.10.3 Clearances

PR

2.10.3.1 General

It is permitted to use either the following method or the alternative method in annex G for a particular component or subassembly or for the whole equipment.

NOTE 1 – The advantages of annex G are as follows:

- CLEARANCES are aligned with the basic safety publication IEC 60664-1 and are therefore harmonized with other safety publications (e.g. for transformers).
- Additional flexibility is provided for the designer due to an improved interpolation method compared to the method in 2.10.3 where steps are taken from one line to the next in tables 2H, 2J and 2K.
- Attenuation of transients within the equipment is considered, including attenuation of transients in PRIMARY CIRCUITS.
- Inconsistencies in table 2H are corrected (4 000 V_{peak} requires 2,0 mm or 2,5 mm for FUNCTIONAL INSULATION and 3,2 mm for BASIC INSULATION).

NOTE 2 – CLEARANCE and electric strength requirements are based on the expected overvoltage transients which may enter the equipment from the AC MAINS SUPPLY. According to IEC 60664-1, the magnitude of these transients is determined by the normal supply voltage and the supply arrangements. These transients are categorized according to IEC 60664-1 into four groups as Overvoltage Categories I to IV (also known as installation categories I to IV). Annex G covers all four Overvoltage Categories. Elsewhere in this standard Overvoltage Category II is assumed.

NOTE 3 – The design of solid insulation and CLEARANCES should be coordinated in such a way that if an incident overvoltage transient exceeds the limits of Overvoltage Category II, the solid insulation can withstand a higher voltage than the CLEARANCES.

For all a.c. power systems, the AC MAINS SUPPLY voltage in tables 2H, 2J and 2K is the line-to-neutral voltage.

NOTE 4 – In Norway, due to the IT power distribution system used (see annex V, figure V.7), the AC MAINS SUPPLY voltage is considered to be equal to the line-to-line voltage, and will remain 230 V in case of a single earth fault.

The specified CLEARANCES are subject to the following minimum values:

- 10 mm for an air gap serving as REINFORCED INSULATION between a part at HAZARDOUS VOLTAGE and an accessible conductive part of the ENCLOSURE of floor-standing equipment or of the non-vertical top surface of desk top equipment;
- 2 mm for an air gap serving as BASIC INSULATION between a part at HAZARDOUS VOLTAGE and an earthed accessible conductive part of the external ENCLOSURE of PLUGGABLE EQUIPMENT TYPE A.

The specified CLEARANCES are not applicable to the air gap between the contacts of THERMOSTATS, THERMAL CUT-OUTS, overload protection devices, switches of microgap construction, and similar components where the CLEARANCE varies with the contacts.

NOTE 5 – For air gaps between contacts of interlock switches, see 2.8.7.1. For air gaps between contacts of disconnect switches, see 3.4.2.

NOTE 6 – CLEARANCES should not be reduced by manufacturing tolerances or by deformation which can occur due to handling, shock and vibration likely to be encountered during manufacture, transport and normal use.

Compliance with 2.10.3 is checked by measurement, taking into account annex F. The following conditions are applicable. There is no electric strength test to verify CLEARANCES.

Movable parts shall be placed in the most unfavourable position.

When measuring CLEARANCES from an ENCLOSURE of insulating material through a slot or opening in the ENCLOSURE, the accessible surface shall be considered to be conductive as if it were covered by metal foil wherever it can be touched by the test finger, figure 2A (see 2.1.1.1), applied without appreciable force (see figure F.12, point B).

When measuring CLEARANCES, 4.2.2, 4.2.3 and 4.2.4 apply.

2.10.3.2 Clearances in primary circuits

CLEARANCES IN PRIMARY CIRCUITS shall comply with the minimum dimensions in table 2H and, where appropriate, table 2J.

Table 2H is applicable to equipment that will not be subjected to transients exceeding Overvoltage Category II according to IEC 60664-1. The appropriate MAINS TRANSIENT VOLTAGES are given in parentheses in each nominal AC MAINS SUPPLY voltage column. If higher transients are expected, additional protection might be necessary in the supply to the equipment or in the installation.

NOTE 1 – Annex G provides an alternative design method for higher transients.

For PRIMARY CIRCUITS operating on nominal AC MAINS SUPPLY voltages up to 300 V, if the PEAK WORKING VOLTAGE in the circuit exceeds the peak value of the AC MAINS SUPPLY voltage, the minimum CLEARANCE for the insulation under consideration is the sum of the following two values:

- the minimum CLEARANCE value from table 2H for a WORKING VOLTAGE equal to the AC MAINS SUPPLY voltage; and
- the appropriate additional CLEARANCE value from table 2J.

For a WORKING VOLTAGE to be used in determining CLEARANCES for PRIMARY CIRCUITS in accordance with table 2H:

- the peak value of any superimposed ripple on a DC VOLTAGE, shall be included;
- non-repetitive transients (due, for example, to atmospheric disturbances) shall not be taken into account;

NOTE 2 – It is assumed that any such non-repetitive transients in a SECONDARY CIRCUIT will not exceed the MAINS TRANSIENT VOLTAGE of the PRIMARY CIRCUIT.

- the voltage of any ELV CIRCUIT, SELV CIRCUIT OR TNV CIRCUIT (including ringing voltage) shall be regarded as zero;

and in accordance with table 2J, where appropriate, for PEAK WORKING VOLTAGES exceeding the values of the AC MAINS SUPPLY voltage, the maximum PEAK WORKING VOLTAGE shall be used.

NOTE 3 – The total CLEARANCES obtained by the use of table 2J lie between the values required for homogeneous and inhomogeneous fields. As a result, they may not assure conformance with the appropriate electric strength test in case of fields which are substantially inhomogeneous.

NOTE 4 – Use of CLEARANCE – tables 2H and 2J:

Select the appropriate column in table 2H for the AC MAINS SUPPLY voltage and Pollution Degree. Select the row appropriate to a WORKING VOLTAGE equal to the AC MAINS SUPPLY voltage. Note the CLEARANCE requirement.

Go to table 2J. Select the appropriate column for the AC MAINS SUPPLY voltage and Pollution Degree and choose the row in that column which covers the actual PEAK WORKING VOLTAGE. Read the additional CLEARANCE required from one of the two right-hand columns and add this to the minimum CLEARANCE from table 2H to give the total minimum CLEARANCE.

Table 2H – Minimum clearances for insulation in primary circuits, and between primary and secondary circuits

CLEARANCES in millimetres																	
WORKING VOLTAGE up to and including		Nominal AC MAINS SUPPLY voltage ≤ 150 V (MAINS TRANSIENT VOLTAGE 1 500 V)						Nominal AC MAINS SUPPLY voltage > 150 V ≤ 300 V (MAINS TRANSIENT VOLTAGE 2 500 V)						Nominal AC MAINS SUPPLY voltage > 300 V ≤ 600 V (MAINS TRANSIENT VOLTAGE 4 000 V)			
Voltage peak or d.c.	Voltage r.m.s. (sinusoidal)	Pollution Degrees 1 and 2			Pollution Degree 3			Pollution Degrees 1 and 2			Pollution Degree 3			Pollution Degrees 1, 2 and 3			
		F	B/S	R	F	B/S	R	F	B/S	R	F	B/S	R	F	B/S	R	
71	50	0,4	1,0 (0,5)	2,0 (1,0)	0,8	1,3 (0,8)	2,6 (1,6)	1,0	2,0 (1,5)	4,0 (3,0)	1,3	2,0 (1,5)	4,0 (3,0)	2,0	3,2 (3,0)	6,4 (6,0)	
210	150	0,5	1,0 (0,5)	2,0 (1,0)	0,8	1,3 (0,8)	2,6 (1,6)	1,4	2,0 (1,5)	4,0 (3,0)	1,5	2,0 (1,5)	4,0 (3,0)	2,0	3,2 (3,0)	6,4 (6,0)	
420	300	F 1,5 B/S 2,0 (1,5) R 4,0 (3,0)											2,5	3,2 (3,0)	6,4 (6,0)		
840	600	F 3,0 B/S 3,2 (3,0) R 6,4 (6,0)															
1 400	1 000	F/B/S 4,2 R 6,4															
2 800	2 000	F/B/S/R 8,4															
7 000	5 000	F/B/S/R 17,5															
9 800	7 000	F/B/S/R 25															
14 000	10 000	F/B/S/R 37															
28 000	20 000	F/B/S/R 80															
42 000	30 000	F/B/S/R 130															
<p>1) The values in the table are applicable to FUNCTIONAL (F), BASIC (B), SUPPLEMENTARY (S) and REINFORCED (R) INSULATION.</p> <p>2) The values in parentheses are applicable to BASIC, SUPPLEMENTARY or REINFORCED INSULATION only if manufacturing is subjected to a quality control programme that provides at least the same level of assurance as the example given in annex R.2. In particular, DOUBLE and REINFORCED INSULATION shall be subjected to ROUTINE TESTS for electric strength.</p> <p>3) For WORKING VOLTAGES between 2 800 V peak or d.c. and 42 000 V peak or d.c., linear interpolation is permitted between the nearest two points, the calculated spacing being rounded up to the next higher 0,1 mm increment.</p>																	

Table 2J – Additional clearances for insulation in primary circuits with peak working voltages exceeding the peak value of the nominal a.c. mains supply voltage

Nominal AC MAINS SUPPLY voltage ≤ 150 V		Nominal AC MAINS SUPPLY voltage > 150 V ≤ 300 V	Additional CLEARANCE mm	
Pollution Degrees 1 and 2	Pollution Degree 3	Pollution Degrees 1, 2 and 3	FUNCTIONAL, BASIC or SUPPLEMENTARY INSULATION	REINFORCED INSULATION
Maximum PEAK WORKING VOLTAGE V	Maximum PEAK WORKING VOLTAGE V	Maximum PEAK WORKING VOLTAGE V		
210 (210)	210 (210)	420 (420)	0	0
298 (288)	294 (293)	493 (497)	0,1	0,2
386 (366)	379 (376)	567 (575)	0,2	0,4
474 (444)	463 (459)	640 (652)	0,3	0,6
562 (522)	547 (541)	713 (729)	0,4	0,8
650 (600)	632 (624)	787 (807)	0,5	1,0
738 (678)	715 (707)	860 (884)	0,6	1,2
826 (756)	800 (790)	933 (961)	0,7	1,4
914 (839)		1 006 (1 039)	0,8	1,6
1 002 (912)		1 080 (1 116)	0,9	1,8
1 090 (990)		1 153 (1 193)	1,0	2,0
		1 226 (1 271)	1,1	2,2
		1 300 (1 348)	1,2	2,4
		– (1 425)	1,3	2,6

The values in parentheses shall be used:
 – When the values in parentheses in table 2H are used in accordance with item 2) of table 2H; and
 – for FUNCTIONAL INSULATION.

2.10.3.3 Clearances in secondary circuits

CLEARANCES IN SECONDARY CIRCUITS shall comply with the minimum dimensions of table 2K.

For a WORKING VOLTAGE to be used in determining CLEARANCES for SECONDARY CIRCUITS in accordance with table 2K:

- the peak value of any superimposed ripple on a DC VOLTAGE, shall be included;
- the peak value shall be used for non-sinusoidal voltages.

SECONDARY CIRCUITS will normally be Overvoltage Category I if the PRIMARY CIRCUIT is Overvoltage Category II; the maximum transients for various AC MAINS SUPPLY voltages in Overvoltage Category I are shown in the column headings of table 2K. However, a floating SECONDARY CIRCUIT shall be subjected to the requirements for PRIMARY CIRCUIT in tables 2H and 2J unless it is in equipment with a protective earthing terminal and either

- it is separated from the PRIMARY CIRCUIT by an earthed metal screen; or

– transients on the SECONDARY CIRCUIT are below the permitted maximum value for Overvoltage Category I (e.g. due to being attenuated by connecting a component, such as a capacitor, between the SECONDARY CIRCUIT and earth). See 2.10.3.4 for the method of measuring the transient level.

NOTE – For CLEARANCES which are provided for compliance with 2.3.2, table 2K applies.

If the TELECOMMUNICATION NETWORK TRANSIENT VOLTAGE is not known, an assumed transient rating of 800 V peak should be used for TNV-2 CIRCUITS and 1,5 kV peak for TNV-1 CIRCUITS and TNV-3 CIRCUITS.

If the TELECOMMUNICATION NETWORK TRANSIENT VOLTAGE is known, the known value should be used.

If it is known that the incoming transients will be attenuated within the equipment, the value should be determined in accordance with 2.10.3.4 b) and be used.

Table 2K – Minimum clearances in secondary circuits

CLEARANCES in millimetres																			
WORKING VOLTAGE up to and including		Nominal AC MAINS SUPPLY voltage ≤ 150 V (transient rating for SECONDARY CIRCUIT 800 V) see 5)						Nominal AC MAINS SUPPLY voltage > 150 V ≤ 300 V (transient rating for SECONDARY CIRCUIT 1500 V) see 5)						Nominal AC MAINS SUPPLY voltage > 300 V ≤ 600 V (transient rating for SECONDARY CIRCUIT 2500 V) see 5)			Circuit not subject to transient overvoltages see 4)		
		Pollution Degrees 1 and 2			Pollution Degree 3			Pollution Degrees 1 and 2			Pollution Degree 3			Pollution Degrees 1, 2 and 3			Pollution Degrees 1 and 2 only		
Voltage peak or d.c.	Voltage r.m.s. (sinusoidal)	F	B/S	R	F	B/S	R	F	B/S	R	F	B/S	R	F	B/S	R	F	B/S	R
71	50	0,4 (0,2)	0,7 (0,2)	1,4 (0,4)	1,0 (0,8)	1,3 (0,8)	2,6 (1,6)	0,7 (0,5)	1,0 (0,5)	2,0 (1,0)	1,0 (0,8)	1,3 (0,8)	2,6 (1,6)	1,7 (1,5)	2,0 (1,5)	4,0 (3,0)	0,4 (0,2)	0,4 (0,2)	0,8 (0,4)
140	100	0,6 (0,2)	0,7 (0,2)	1,4 (0,4)	1,0 (0,8)	1,3 (0,8)	2,6 (1,6)	0,7 (0,5)	1,0 (0,5)	2,0 (1,0)	1,0 (0,8)	1,3 (0,8)	2,6 (1,6)	1,7 (1,5)	2,0 (1,5)	4,0 (3,0)	0,6 (0,2)	0,7 (0,2)	1,4 (0,4)
210	150	0,6 (0,2)	0,9 (0,2)	1,8 (0,4)	1,0 (0,8)	1,3 (0,8)	2,6 (1,6)	0,7 (0,5)	1,0 (0,5)	2,0 (1,0)	1,0 (0,8)	1,3 (0,8)	2,6 (1,6)	1,7 (1,5)	2,0 (1,5)	4,0 (3,0)	0,6 (0,2)	0,7 (0,2)	1,4 (0,4)
280	200	F 1,1 (0,8) B/S 1,4 (0,8) R 2,8 (1,6)												1,7 (1,5)	2,0 (1,5)	4,0 (3,0)	1,1 (0,2)	1,1 (0,2)	2,2 (0,4)
420	300	F 1,6 (1,0) B/S 1,9 (1,0) R 3,8 (2,0)												1,7 (1,5)	2,0 (1,5)	4,0 (3,0)	1,4 (0,2)	1,4 (0,2)	2,8 (0,4)
700	500							F/B/S 2,5			R, 5,0								
840	600							F/B/S 3,2			R, 5,0								
1 400	1 000							F/B/S 4,2			R, 5,0								
2 800	2 000							F/B/S/R 8,4			See 6)								
7 000	5 000							F/B/S/R 17,5			See 6)								
9 800	7 000							F/B/S/R 25			See 6)								
14 000	10 000							F/B/S/R 37			See 6)								
26 000	20 000							F/B/S/R 80			See 6)								

Table 2K – Minimum clearances in secondary circuits Continued

CLEARANCES in millimetres																					
WORKING VOLTAGE up to and including		Nominal AC MAINS SUPPLY voltage ≤ 150 V (transient rating for SECONDARY CIRCUIT 800 V) see 5)						Nominal AC MAINS SUPPLY voltage > 150 V ≤ 300 V (transient rating for SECONDARY CIRCUIT 1500 V) see 5)						Nominal AC MAINS SUPPLY voltage > 300 V ≤ 600 V (transient rating for SECONDARY CIRCUIT 2500 V) see 5)			Circuit not subject to transient overvoltages see 4)				
		Pollution Degrees 1 and 2			Pollution Degree 3			Pollution Degrees 1 and 2			Pollution Degree 3			Pollution Degrees 1, 2 and 3			Pollution Degrees 1 and 2 only				
Voltage peak or d.c.	Voltage r.m.s. (sinusoidal)	F	B/S	R	F	B/S	R	F	B/S	R	F	B/S	R	F	B/S	R	F	B/S	R		
42 000	30 000	F/B/S/R 130 See 6)																			
<p>1) The values in the table are applicable to FUNCTIONAL (F), BASIC (B), SUPPLEMENTARY (S) and REINFORCED (R) INSULATION.</p> <p>2) The values in parentheses are applicable to BASIC, SUPPLEMENTARY or REINFORCED INSULATION only if manufacturing is subjected to a quality control programme that provides at least the same level of assurance as the example given in annex R.2. In particular, DOUBLE and REINFORCED INSULATION shall be subjected to ROUTINE TESTS for electric strength.</p> <p>3) For WORKING VOLTAGES between 2 800 V peak or d.c. and 42 000 V peak or d.c., linear interpolation is permitted between the nearest two points, the calculated spacing being rounded up to the next higher 0,1 mm increment.</p> <p>4) The values are applicable to d.c. SECONDARY CIRCUITS which are reliably connected to earth and have capacitive filtering which limits the peak-to-peak ripple to 10 % of the DC VOLTAGE.</p> <p>5) Where transients in the equipment exceed this value, the appropriate higher CLEARANCE shall be used.</p> <p>6) Compliance with a CLEARANCE value of 8,4 mm or greater is not required if the CLEARANCE path is:</p> <ul style="list-style-type: none"> – entirely through air, or – wholly or partly along the surface of an insulating material of Material Group I; – and the insulation involved passes an electric strength test according to 5.2.2 using: – an a.c. test voltage whose r.m.s. value is equal to 1,06 times the PEAK WORKING VOLTAGE, or – a d.c. test voltage equal to the peak value of the a.c. test voltage prescribed above. <p>If the CLEARANCE path is partly along the surface of a material that is not Material Group I, the electric strength test is conducted across the air gap only.</p>																					

2.10.3.4 Measurement of transient levels

The following tests are conducted only where it is required to determine whether or not transient voltages across the CLEARANCE in any circuit are lower than normal, due, for example, to the effect of a filter in the equipment. The transient voltage across the CLEARANCE is measured using the following test procedure, and the CLEARANCE shall be based on the measured value.

During the tests, the equipment is connected to its separate power supply unit, if any, but is not connected to the mains, nor to any TELECOMMUNICATION NETWORKS, and any surge suppressors in PRIMARY CIRCUITS are disconnected.

A voltage measuring device is connected across the CLEARANCE in question.

a) Transients due to mains overvoltages

To measure the reduced level of transients due to mains overvoltages, the impulse test generator of annex N is used to generate 1,2/50 μ s impulses, with U_c equal to the MAINS TRANSIENT VOLTAGE given in the column headings of table 2H.

Three to six impulses of alternating polarity, with intervals of at least 1 s between impulses, are applied between each of the following points where relevant:

- line-to-line;
- all line conductors joined together and neutral;
- all line conductors joined together and protective earth;
- neutral and protective earth.

b) Transients due to TELECOMMUNICATION NETWORK overvoltages

To measure the reduced level of transients due to TELECOMMUNICATION NETWORK overvoltages, the impulse test generator of annex N is used to generate 10/700 μ s impulses, with U_c equal to the TELECOMMUNICATION NETWORK TRANSIENT VOLTAGE.

If the TELECOMMUNICATION NETWORK TRANSIENT VOLTAGE is not known for the TELECOMMUNICATION NETWORK in question, it shall be taken as:

- 1 500 V_{peak} if the circuit connected to the TELECOMMUNICATION NETWORK is a TNV-1 CIRCUIT or a TNV-3 CIRCUIT; and
- 800 V_{peak} if the circuit connected to the TELECOMMUNICATION NETWORK is an SELV CIRCUIT or a TNV-2 CIRCUIT.

Three to six impulses of alternating polarity, with intervals of at least 1 s between impulses, are applied between each of the following TELECOMMUNICATION NETWORK connection points:

- each pair of terminals (e.g. A and B or tip and ring) in an interface;
- all terminals of a single interface type joined together and earth.

2.10.4 Creepage distances

P

CREEPAGE DISTANCES shall be not less than the appropriate minimum values specified in table 2L, taking into account the value of the WORKING VOLTAGE, the Pollution Degree and the material group.

For REINFORCED INSULATION, the values for CREEPAGE DISTANCE are twice the values for BASIC INSULATION in table 2L.

If the CREEPAGE DISTANCE derived from table 2L is less than the applicable CLEARANCE from tables 2H and 2J, or from table 2K, as appropriate, then the value for that CLEARANCE shall be applied for the minimum CREEPAGE DISTANCE.

It is permitted to use minimum CREEPAGE DISTANCES equal to the applicable CLEARANCES for glass, mica, ceramic or similar materials.

For the WORKING VOLTAGE to be used in determining CREEPAGE DISTANCES:

- the actual r.m.s. or d.c. value shall be used;
- if the d.c. value is used, any superimposed ripple shall not be taken into account;
- short-term conditions (e.g. in cadenced ringing signals in TNV CIRCUITS) shall not be taken into account;
- short-term disturbances (e.g. transients) shall not be taken into account.

When determining the WORKING VOLTAGE for a TNV CIRCUIT connected to a TELECOMMUNICATION NETWORK whose characteristics are not known, the normal operating voltages shall be assumed to be the following values:

- 60 V d.c. for TNV-1 circuits;
- 120 V d.c. for TNV-2 circuits and TNV-3 circuits.

Material Groups are classified as follows:

Material group I	$600 \leq \text{CTI}$ (comparative tracking index)
Material group II	$400 \leq \text{CTI} < 600$
Material group IIIa	$175 \leq \text{CTI} < 400$
Material group IIIb	$100 \leq \text{CTI} < 175$

The Material Group is verified by evaluation of the test data for the material according to IEC 60112 using 50 drops of solution A.

If the material group is not known, Material Group IIIb shall be assumed.

If a CTI of 175 or greater is needed, and the data is not available, the Material Group can be established with a test for proof tracking index (PTI) as detailed in IEC 60112. A material may be included in a group if its PTI established by these tests is equal to, or greater than, the lower value of the CTI specified for the group.

Table 2L – Minimum creepage distances

CREEPAGE DISTANCES in millimetres							
WORKING VOLTAGE V r.m.s. or d.c.	FUNCTIONAL, BASIC and SUPPLEMENTARY INSULATION						
	Pollution Degree 1	Pollution Degree 2			Pollution Degree 3		
	Material Group	Material Group			Material Group		
	I, II, IIIa or IIIb	I	II	IIIa +or IIIb	I	II	IIIa or IIIb
≤ 50	Use the CLEARANCE from the appropriate table	0,6	0,9	1,2	1,5	1,7	1,9
100		0,7	1,0	1,4	1,8	2,0	2,2
125		0,8	1,1	1,5	1,9	2,1	2,4
150		0,8	1,1	1,6	2,0	2,2	2,5
200		1,0	1,4	2,0	2,5	2,8	3,2
250		1,3	1,8	2,5	3,2	3,6	4,0
300		1,6	2,2	3,2	4,0	4,5	5,0
400		2,0	2,8	4,0	5,0	5,6	6,3
600		3,2	4,5	6,3	8,0	9,6	10,0
800		4,0	5,6	8,0	10,0	11,0	12,5
1 000	5,0	7,1	10,0	12,5	14,0	16,0	

Linear interpolation is permitted between the nearest two points, the calculated spacing being rounded to the next higher 0,1 mm increment.

Compliance is checked by measurement, taking into account annex F.

The following conditions are applicable.

Movable parts are placed in their most unfavourable positions.

For equipment incorporating ordinary NON-DETACHABLE POWER SUPPLY CORDS, CREEPAGE DISTANCE measurements are made with supply conductors of the largest cross-sectional area specified in 3.3.4, and also without conductors.

When measuring CREEPAGE DISTANCES from an ENCLOSURE of insulating material through a slot or opening in the ENCLOSURE, the accessible surface is considered to be conductive as if it were covered by metal foil wherever it can be touched by the test finger, figure 2A (see 2.1.1.1), applied without appreciable force (see figure F.12, point of B).

DE

U

2.10.5 Solid insulation

The adequacy of solid insulation is verified by electric strength tests according to 5.2.

NOTE 1 – The term “solid insulation” refers to material that provides electrical insulation between two opposite surfaces, not along an outer surface. Its required properties are specified either as the actual minimum distance through the insulation (see 2.10.5.1), or by other requirements and tests in this standard instead of a minimum distance.

NOTE 2 – See also 3.1.4.

2.10.5.1 Minimum distance through insulation

Except where 2.1.1.3 or another subclause of 2.10.5 applies, distances through insulation shall be dimensioned according to PEAK WORKING VOLTAGE and to the application of the insulation (see 2.9), and as follows:

- if the PEAK WORKING VOLTAGE does not exceed 71 V, there is no requirement for distance through insulation;
- if the PEAK WORKING VOLTAGE exceeds 71 V, the following rules apply:
 - for FUNCTIONAL INSULATION and BASIC INSULATION there is no requirement at any PEAK WORKING VOLTAGE for distance through insulation;
 - SUPPLEMENTARY INSULATION OR REINFORCED INSULATION shall have a minimum distance through insulation of 0,4 mm.

The requirements of 2.10.5.1 also apply to gel dielectrics such as are used in some opto-couplers.

There is no distance through insulation requirement for SUPPLEMENTARY INSULATION OR REINFORCED INSULATION consisting of an insulating compound completely filling the casing of a semiconductor component (e.g. an opto-coupler), so that CLEARANCES and CREEPAGE DISTANCES do not exist, if the component:

- passes the tests and inspection criteria of 2.10.8; and
- is subjected to ROUTINE TESTS for electric strength during manufacturing, using the appropriate value of the test voltage in 5.2.2.

Compliance is checked by inspection and measurement.

2.10.5.2 Thin sheet material

NOTE – The requirements for wound components are given in 2.10.5.4.

Insulation in thin sheet materials is permitted, irrespective of its thickness, provided that it is used within the equipment ENCLOSURE and is not subject to handling or abrasion during OPERATOR servicing, and one of the following applies:

- SUPPLEMENTARY INSULATION comprises at least two layers of material, each of which will pass the electric strength test for SUPPLEMENTARY INSULATION; OR
- SUPPLEMENTARY INSULATION comprises three layers of material for which all combinations of two layers together will pass the electric strength test for SUPPLEMENTARY INSULATION; OR
- REINFORCED INSULATION comprises at least two layers of material, each of which will pass the electric strength test for REINFORCED INSULATION; OR
- REINFORCED INSULATION comprises three layers of material for which all combinations of two layers together will pass the electric strength test for REINFORCED INSULATION.

There is no requirement for all layers of insulation to be of the same material.

Solvent-based enamel coatings are not considered to be insulation in thin sheet material.

Compliance is checked by inspection and by electric strength test.

2.10.5.3 Printed boards

For the inner layers of multi-layer boards, the distance between two adjacent tracks on the same layer of a printed circuit board is treated as distance through insulation (see 2.10.5.1).

SUPPLEMENTARY OR REINFORCED INSULATION between conductor layers in double-sided, single-layer printed boards, multi-layer printed boards, and metal core printed boards, shall have a minimum thickness of 0,4 mm or meet the requirements according to table 2M.

Table 2M – Insulation in printed boards

Insulation	Type tests ¹⁾	ROUTINE TESTS for electric strength ³⁾
Two layers of sheet insulating material including pre-preg ²⁾	No	Yes
Three or more layers of sheet insulating material including pre-preg ²⁾	No	No
A ceramic coating that is cured at ≥ 500 °C	No	Yes
An insulation system, with two or more coatings, that is cured at < 500 °C	Yes	Yes
1) Thermal ageing and thermal cycling of 2.10.6 followed by the electric strength test of 5.2.2. 2) Layers of pre-preg are counted before curing. 3) Electric strength testing is carried out on the finished printed circuit board. NOTE – Pre-preg is the term used for a layer of glass cloth impregnated with a partially cured resin.		

Compliance is checked by inspection and measurement and by electric strength tests.

Where ROUTINE TESTS are required, the test voltage is the relevant test voltage of 5.2.2. The electric strength tests apply to the overall SUPPLEMENTARY OF REINFORCED INSULATION.

2.10.5.4 Wound components

P U

Where BASIC, SUPPLEMENTARY, OF REINFORCED INSULATION is required between windings, they shall be separated by interleaved insulation complying with 2.10.5.1 or 2.10.5.2, or both, unless one of the following wire constructions a), b) or c) is used.

- a) Wire that has insulation, other than solvent-based enamel, complying with 2.10.5.1.
- b) Wire that has multi-layer extruded or spirally wrapped insulation (where the layers can be individually tested for electric strength) complying with 2.10.5.2 and passes the tests of annex U.
- c) Wire that has multi-layer extruded or spirally wrapped insulation (where only the finished wire can be tested) and passes the tests of annex U.

NOTE 1 – See also 6.2.1.

In 2.10.5.4 c), the minimum number of constructional layers applied to the conductor shall be as follows:

- BASIC INSULATION: two wrapped layers or one extruded layer;
- SUPPLEMENTARY INSULATION: two layers, wrapped or extruded;
- REINFORCED INSULATION: three layers, wrapped or extruded.

In 2.10.5.4 b) and 2.10.5.4 c), for spirally wrapped insulation where the CREEPAGE DISTANCES between layers, as wrapped, are less than those given in table 2L for pollution degree 1, the path between layers shall be sealed as for a cemented joint in 2.10.8 and the test voltages of the TYPE TESTS in clause U.2 are increased to 1,6 times their normal values.

NOTE 2 – One layer of material wound with more than 50 % overlap is considered to constitute two layers.

Where two insulated wires or one bare and one insulated wire are in contact inside the wound component, crossing each other at an angle between 45° and 90° and subject to winding tension, protection against mechanical stress shall be provided. This protection can be achieved, for example, by providing physical separation in the form of insulating sleeving or sheet material, or by using double the required number of insulation layers.

The finished component shall pass ROUTINE TESTS for electric strength using the appropriate values of test voltages in 5.2.2.

Compliance is checked by inspection and measurement, and if applicable, as specified in annex U. However, the tests of annex U are not repeated if the material data sheets confirm compliance.

2.10.6 Coated printed boards

R

2.10.6.1 General

For printed boards whose surface conductors are coated with a suitable coating material, the minimum separation distances of table 2N are applicable to conductors before they are coated, subject to the following requirements.

Either one or both conductive parts and at least 80 % of the distances over the surface between the conductive parts shall be coated. Between any two uncoated conductive parts and over the outside of the coating, the minimum distances in tables 2H, 2J or 2K apply.

The values in table 2N shall be used only if manufacturing is subject to a quality control programme that provides at least the same level of assurance as the example given in annex R.1. In particular, DOUBLE and REINFORCED INSULATION shall be subject to ROUTINE TESTS for electric strength.

In default of the above conditions, the requirements of 2.10.1, 2.10.2, 2.10.3 and 2.10.4 shall apply.

The coating process, the coating material and the base material shall be such that uniform quality is assured and the separation distances under consideration are effectively protected.

Compliance is checked by measurement taking into account figure F.11, and by the following tests.

2.10.6.2 Sample preparation and preliminary inspection

Three sample boards (or, for 2.10.9, two components and one board) identified as samples 1, 2 and 3 are required. It is permitted to use either actual boards or specially produced samples with representative coating and minimum separations. Each sample board shall be representative of the minimum separations used, and coated. Each sample is subjected to the full sequence of manufacturing processes, including soldering and cleaning, to which it is normally subjected during equipment assembly.

When visually inspected, the boards shall show no evidence of pinholes or bubbles in the coating or breakthrough of conductive tracks at corners.

Table 2N – Minimum separation distances for coated printed boards

WORKING VOLTAGE		FUNCTIONAL, BASIC or SUPPLEMENTARY INSULATION	REINFORCED INSULATION
V r.m.s. or d.c.		mm	mm
	up to and including	63	0,1
Over	63 up to and including	125	0,2
Over	125 up to and including	160	0,3
Over	160 up to and including	200	0,4
Over	200 up to and including	250	0,6
Over	250 up to and including	320	0,8
Over	320 up to and including	400	1,0
Over	400 up to and including	500	1,3
Over	500 up to and including	630	1,8
Over	630 up to and including	800	2,4
Over	800 up to and including	1 000	2,8
Over	1 000 up to and including	1 250	3,4
Over	1 250 up to and including	1 600	4,1
Over	1 600 up to and including	2 000	5,0
Over	2 000 up to and including	2 500	6,3
Over	2 500 up to and including	3 200	8,2
Over	3 200 up to and including	4 000	10
Over	4 000 up to and including	5 000	13
Over	5 000 up to and including	6 300	16
Over	6 300 up to and including	8 000	20
Over	8 000 up to and including	10 000	26
Over	10 000 up to and including	12 500	33
Over	12 500 up to and including	16 000	43
Over	16 000 up to and including	20 000	55
Over	20 000 up to and including	25 000	70
Over	25 000 up to and including	30 000	86

For voltages between 2 000 V and 30 000 V linear interpolation is permitted between the nearest two points, the calculated spacing being rounded up to the next higher 0,1 mm increment.

2.10.6.3 Thermal cycling

Sample 1 is subjected 10 times to the following sequence of temperature cycles:

68 h at $T_1 \pm 2 \text{ }^\circ\text{C}$;

1 h at $25 \text{ }^\circ\text{C} \pm 2 \text{ }^\circ\text{C}$;

2 h at $0 \text{ }^\circ\text{C} \pm 2 \text{ }^\circ\text{C}$;

not less than 1 h at $25 \text{ }^\circ\text{C} \pm 2 \text{ }^\circ\text{C}$.

$T_1 = T_2 + T_{mra} - T_{amb} + 10 \text{ K}$, measured in accordance with 1.4.5 and, where relevant, 1.4.13, or $100 \text{ }^\circ\text{C}$, whichever is higher. However, the 10 K margin is not added if the temperature is measured by an embedded thermocouple.

T_2 is the temperature of the parts measured during the test of 4.5.1.

The significances of T_{mra} and T_{amb} are as given in 1.4.12.

The period of time taken for the transition from one temperature to another is not specified, but the transition is permitted to be gradual.

2.10.6.4 Thermal ageing

Sample 2 shall be aged in a full draught oven at a temperature and for a time duration chosen from the graph of figure 2G using the temperature index line that corresponds to the maximum operating temperature of the coated board. The temperature of the oven shall be maintained at the specified temperature $\pm 2 \text{ }^\circ\text{C}$. The temperature used to determine the temperature index line is the highest temperature on the board where safety is involved.

When using figure 2G, interpolation is permitted between the nearest two temperature index lines.

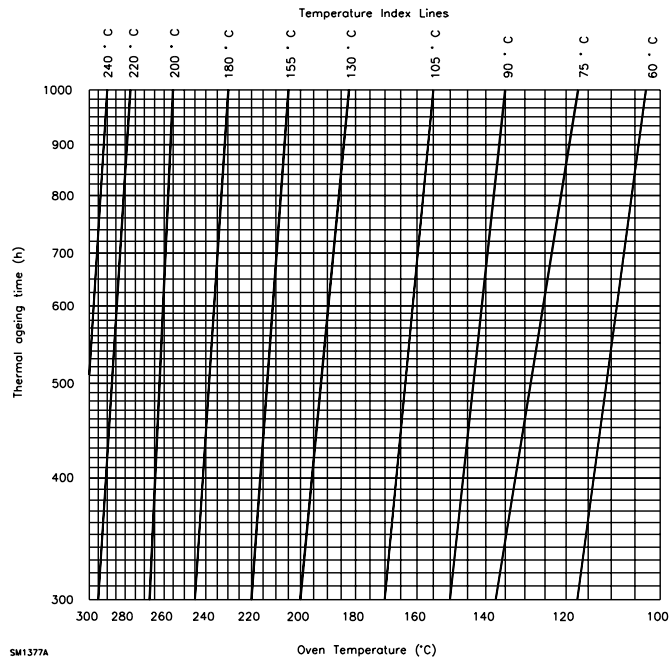

Figure 2G – Thermal ageing time

2.10.6.5 Electric strength test

Samples 1 and 2 are then subjected to the humidity conditioning of 2.9.2 (48 h) and shall withstand the relevant electric strength test of 5.2.2 between conductors.

2.10.6.6 Abrasion resistance test

Sample board 3 is subjected to the following test.

Scratches are made across five pairs of conducting parts and the intervening separations at points where the separations will be subject to the maximum potential gradient during the tests.

The scratches are made by means of a hardened steel pin, the end of which has the form of a cone having a tip angle of 40°, its tip being rounded and polished, with a radius of 0,25 mm ± 0,02 mm.

Scratches are made by drawing the pin along the surface in a plane perpendicular to the conductor edges at a speed of 20 mm/s ± 5 mm/s as shown in figure 2H. The pin is so loaded that the force exerted along its axis is 10 N ± 0,5 N. The scratches shall be at least 5 mm apart and at least 5 mm from the edge of the specimen.

After this test, the coating layer shall neither have loosened nor have been pierced and it shall withstand an electric strength test as specified in 5.2.2 between conductors. In the case of the metal core printed boards, the substrate is one of the conductors.

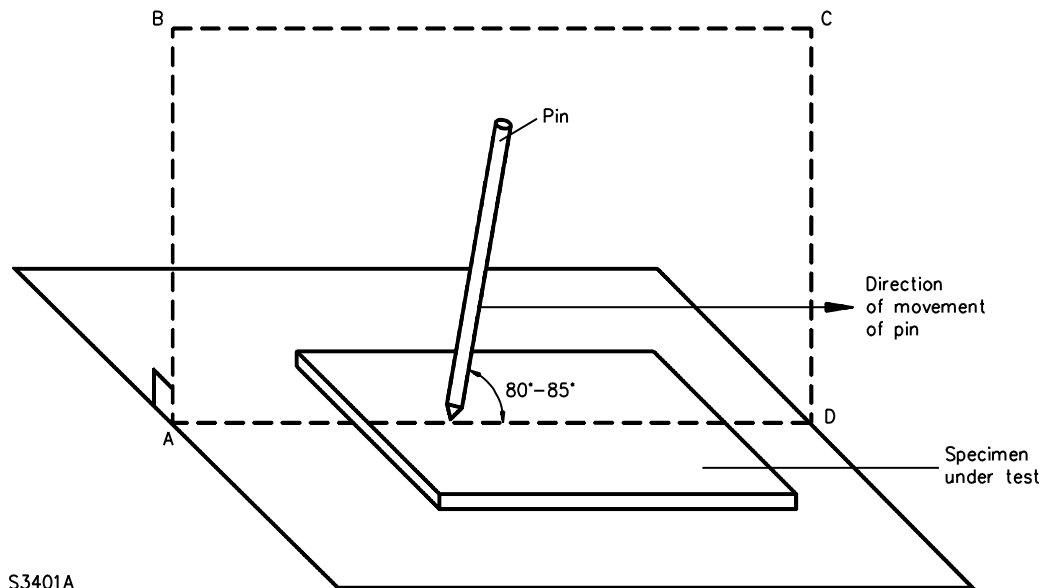

NOTE – The pin is in the plane ABCD which is perpendicular to the specimen under test.

Figure 2H – Abrasion resistance test for coating layers

2.10.7 Enclosed and sealed parts

For components or subassemblies which are adequately enclosed by enveloping or hermetic sealing to prevent ingress of dirt and moisture, the values for Pollution Degree 1 apply to internal CLEARANCES and CREEPAGE DISTANCES.

NOTE – Some examples of such construction include parts in boxes that are hermetically sealed by adhesive or otherwise, and parts enveloped in a dip coat.

Compliance is checked by inspection from the outside, measurement and, if necessary, by test. A component or subassembly is considered to be adequately enclosed if a sample passes the following sequence of tests.

The sample is subjected 10 times to the following sequence of temperature cycles:

68 h at $T_1 \pm 2 \text{ }^\circ\text{C}$;

1 h at $25 \text{ }^\circ\text{C} \pm 2 \text{ }^\circ\text{C}$;

2 h at $0 \text{ }^\circ\text{C} \pm 2 \text{ }^\circ\text{C}$;

not less than 1 h at $25 \text{ }^\circ\text{C} \pm 2 \text{ }^\circ\text{C}$.

$T_1 = T_2 + T_{mra} - T_{amb} + 10 \text{ K}$, measured in accordance with 1.4.5 and, where relevant, 1.4.8, or $85 \text{ }^\circ\text{C}$, whichever is higher. However, the 10 K margin is not added if the temperature is measured by an embedded thermocouple or by the resistance method.

T_2 is the temperature of the parts measured during the test of 4.5.1.

The significance of T_{mra} and T_{amb} is as given in 1.4.12.

The period of time taken for the transition from one temperature to another is not specified, but the transition is permitted to be gradual.

The sample is allowed to cool to room temperature and is subjected to the humidity conditioning of 2.9.2, followed immediately by the electric strength tests of 5.2.2.

For transformers, magnetic couplers and similar devices, where insulation is relied upon for safety, a voltage of 500 V r.m.s at 50 Hz to 60 Hz is applied between windings during the thermal cycling conditioning. No evidence of insulation breakdown shall occur during this test.

2.10.8 Spacings filled by insulating compound

Where distances between conductive parts are filled with insulating compound, including where insulation is reliably cemented together with insulating compound, so that CLEARANCES and CREEPAGE DISTANCES do not exist, only the requirements for distance through insulation of 2.10.5.1 apply.

NOTE 1 – Some examples of such treatment are variously known as potting, encapsulation and vacuum impregnation.

NOTE 2 – Acceptable forms of construction include:

- components or subassemblies which are treated with an insulating compound that fills voids; and
- internal insulation of multi-layer printed boards.

Compliance is checked by inspection, measurement and test. There is no measurement of CLEARANCES and CREEPAGE DISTANCES if samples pass the thermal cycling, humidity conditioning and electric strength test specified in 2.10.7, applied as follows:

- for components where insulating compound forms solid insulation between conductive parts, a single finished component is tested. The tests are followed by inspection, including sectioning, and measurement. There shall be neither cracks nor voids in the insulating compound such as would affect compliance with 2.10.5.1.
- for components where insulating compound forms a cemented joint with other insulating parts, the reliability of the joint is checked by subjecting three samples to the electric strength tests applied directly to the cemented joint. If a winding of solvent-

based enamelled wire is used in the component, it is replaced for the test by a metal foil or by a few turns of bare wire, placed closed to the cemented joint. The three samples are then tested as follows:

- one of the samples is subjected to the relevant electric strength test of 5.2.2 immediately after the last period at highest temperature during thermal cycling, except that the test voltage is multiplied by 1,6;*
- the other samples are subjected to the relevant electric strength test of 5.2.2 after the humidity conditioning, except that the test voltage is multiplied by 1,6.*

2.10.9 Component external terminations

The requirements of 2.10.1, 2.10.2, 2.10.3 and 2.10.4 are applicable to the spacings between external terminations of components unless they have a coating of material satisfying the requirements of 2.10.6 including the quality control requirements, an example of which is given in annex R.1. In such a case, the minimum separation distances of table 2N (see 2.10.6.1) apply to the component before coating. Between any two uncoated conductive parts and over the outside of the coating, the minimum distances of tables 2H, 2J, 2K and 2L shall be applied.

If coatings are used over terminations to increase effective CREEPAGE DISTANCES and CLEARANCES, the mechanical arrangement and rigidity of the terminations shall be adequate to ensure that, during normal handling, assembly into equipment and subsequent use, the terminations will not be subject to deformation which would crack the coating or reduce the separation distances between conductive parts below the values in table 2N (see 2.10.6.1).

Compliance is checked by inspection, taking into account figure F.10, and by applying the sequence covered by 2.10.6.2, 2.10.6.3, 2.10.6.4 and 2.10.6.5. This test is carried out on a completed assembly including the component(s).

The abrasion resistance test of 2.10.6.6 is carried out on a specially prepared sample printed board as described for sample 3 in 2.10.6.2, except that the separation between the conductive parts shall be representative of the minimum separations and maximum potential gradients used in the assembly.

2.10.10 Insulation with varying dimensions

If the insulation of a transformer has different WORKING VOLTAGES along the length of the winding, it is permitted to vary CLEARANCES, CREEPAGE DISTANCES and distances through insulation accordingly.

NOTE – An example of such a construction is a 30 kV winding, consisting of multiple bobbins connected in series, and earthed at one end.

3 Wiring, connections and supply

P

3.1 General

3.1.1 Current rating and overcurrent protection

NAE

The cross-sectional area of internal wires and INTERCONNECTING CABLES shall be adequate for the current they are intended to carry when the equipment is operating under NORMAL LOAD such that the maximum permitted temperature of conductor insulation is not exceeded.

All internal wiring (including bus-bars) and INTERCONNECTING CABLES used in the distribution of PRIMARY CIRCUIT power and all INTERCONNECTING CABLES shall be protected against overcurrent and short circuit by suitably rated protective devices. D1

Wiring not directly involved in the distribution path does not require protection if it can be shown that hazards in the meaning of this standard are unlikely (e.g. indicating circuits).

Examples considered to comply with this requirement are: D1

– conductors provided with overcurrent protection in accordance with Article 240 of the National Electrical Code, ANSI/NFPA 70, and the Canadian Electrical Code, Part I, CSA C22.1, Section 14; D1
D1
D1

– internal conductors supplied by a power source that is limited to the output voltage and current values specified in table 2B or is limited to the output voltage values and provided with an overcurrent protective device with a RATED CURRENT value as specified in table 2C; D1
D1
D1
D1

– INTERCONNECTING CABLES supplied by a limited power source (see 2.5); D1

– a 20-A protective device used with any size wire in the primary. D1

NOTE 1 – Devices for overload protection of components may also provide protection of associated wiring.

NOTE 2 – Internal circuits connected to the AC MAINS SUPPLY may require individual protection depending on reduced wire size and length of conductors.

Compliance is checked by inspection and, as appropriate, by the tests of 4.5.1 and/or 5.3. D1

3.1.2 Protection against mechanical damage

Wireways shall be smooth and free from sharp edges. Wires shall be protected so that they do not come into contact with burrs, cooling fins, moving parts, etc., which could cause damage to the insulation of conductors. Holes in metal, through which insulated wires pass, shall have smooth well-rounded surfaces or shall be provided with bushings.

It is permitted for wires to be in close contact with wire wrapping posts and the like if any breakdown of insulation will not create a hazard, or if adequate mechanical protection is provided by the insulation system.

Compliance is checked by inspection.

3.1.3 Securing of internal wiring

Internal wiring shall be routed, supported, clamped or secured in a manner that reduces the likelihood of:

- excessive strain on wire and on terminal connections; and
- loosening of terminal connections; and
- damage of conductor insulation.

Compliance is checked by inspection.

3.1.4 Insulation of conductors

Except as covered in 2.1.1.3 b), insulation of individual conductors of internal wiring shall fulfil the requirements of 2.10.5 and be capable of withstanding the applicable electric strength test specified in 5.2.2.

Where a power supply cord, whose insulating properties comply with those of the cord types of 3.2.5, is used inside the equipment, either as an extension of the external power supply cord or as an independent cable, the sheath of the power supply cord is considered to be adequate SUPPLEMENTARY INSULATION for the purpose of 3.1.4.

NOTE – Requirements regarding colours of insulation are in 2.6.3.4.

Compliance is checked by inspection and evaluation of test data showing that the insulation withstands the relevant test voltage.

If such applicable test data is not available, compliance is checked by applying the electric strength test using a sample of approximately 1 m in length and by applying the relevant test voltage as follows:

- *for insulation of a conductor: by the voltage test method given in clause 3 of IEC 60885-1, using the relevant test voltage in 5.2.2 in this standard for the grade of insulation under consideration; and*
- *for SUPPLEMENTARY INSULATION (e.g. sleeving around a group of conductors): between a conductor inserted into the sleeve and metal foil wrapped tightly round the sleeve for a length of at least 100 mm.*

3.1.5 Beads and ceramic insulators

Beads and similar ceramic insulators on conductors shall

- be so fixed or supported that they cannot change their position in such a way that a hazard would be created ; and
- not rest on sharp edges or sharp corners.

If beads are located inside flexible metal conduits, they shall be contained within an insulating sleeve, unless the conduit is mounted or secured in such a way that movement in normal use would not create a hazard.

Compliance is checked by inspection and, where necessary, by the following test.

A force of 10 N is applied to the insulators or to the conduit. The resulting movement, if any, shall not create a hazard in the meaning of this standard.

3.1.6 Screws for electrical contact pressure

Where electrical contact pressure is required, a screw shall engage at least two complete threads into a metal plate, a metal nut or a metal insert.

Screws of insulating material shall not be used where electrical connections, including protective earthing, are involved, or where their replacement by metal screws could impair SUPPLEMENTARY OR REINFORCED INSULATION.

Where screws of insulating material contribute to other safety aspects, they shall be engaged by at least two complete threads.

NOTE – See also 2.6.5.7 for screws used for protective earthing continuity.

Compliance is checked by inspection.

3.1.7 Non-metallic materials in electrical connections

Electrical connections, including those for protective earthing functions (see 2.6), shall be so designed that contact pressure is not transmitted through insulating material unless there is sufficient resilience in the metallic parts to compensate for any possible shrinkage or distortion of the insulating material.

Compliance is checked by inspection.

3.1.8 Self-tapping and spaced thread screws

Spaced thread (sheet metal) screws shall not be used for the connection of current-carrying parts, unless they clamp these parts directly in contact with each other and are provided with a suitable means of locking.

Self-tapping (thread-cutting or thread-forming) screws shall not be used for the electrical connection of current-carrying parts, unless they generate a full form standard machine screw thread. Moreover, such screws shall not be used if they are operated by the USER or installer unless the thread is formed by a swaging action.

NOTE – See also 2.6.5.7 for screws used for protective earthing continuity.

Compliance is checked by inspection.

3.1.9 Termination of conductors

Conductors shall be provided with a means (e.g. barriers or fixing), or be so terminated, that they and their terminators (e.g. ring terminals, flat quick-connect terminals, etc.) cannot, in normal use, become so displaced that CLEARANCES OR CREEPAGE DISTANCES are reduced to less than the values specified in 2.10.

It is permitted to use soldered, welded, crimped, screwless (push-in) and similar terminations for the connection of conductors. For soldered terminations, the conductor shall be positioned or fixed so that reliance is not placed upon the soldering alone to maintain the conductor in position.

In multiway plugs and sockets, and wherever shorting could otherwise occur, means shall be provided to prevent contact between parts in SELV CIRCUITS OR TNV CIRCUITS and parts at HAZARDOUS VOLTAGE due to loosening of a terminal or breaking of a wire at a termination.

Compliance is checked by inspection, by measurement and, where necessary, by the following test.

A force of 10 N is applied to the conductor near its termination point. The conductor shall not break away or pivot on its terminal to the extent that required CLEARANCE OF CREEPAGE DISTANCES are reduced below the values required in 2.10.

For the purpose of assessing compliance it is assumed that:

- two independent fixings will not become loose at the same time; and*
- parts fixed by means of screws or nuts provided with self-locking washers or other means of locking are not liable to become loose.*

NOTE – Spring washers and the like can provide satisfactory locking.

Examples of constructions regarded as meeting the requirements include:

- close-fitting tubing (e.g. a heat shrink or synthetic rubber sleeve), applied over the wire and its termination;*

- conductors connected by soldering and held in place near to the termination, independently of the soldered connection;
- conductors connected by soldering and "hooked in" before soldering, provided that the hole through which the conductor is passed is not unduly large;
- conductors connected to screw terminals, with an additional fixing near to the terminal that clamps, in the case of stranded conductors, the insulation and not only the conductors;
- conductors connected to screw terminals and provided with terminators which are unlikely to become free (e.g. ring lugs crimped onto the conductors). The pivoting of such terminators is considered;
- short rigid conductors that remain in position when the terminal screw is loosened.

3.1.10 Sleeving on wiring

Where sleeving is used as SUPPLEMENTARY INSULATION on internal wiring, it shall be retained in position by positive means.

Compliance is checked by inspection.

Examples of constructions that are considered to meet the intent of this requirement include:

- sleeving that can be removed only by breaking or cutting of either the wiring or sleeving;
- sleeving that is clamped at both ends;
- heat shrinkable sleeving that tightens against the wire insulation;
- sleeving that is of such length that it will not slip.

3.2 Connection to a.c. mains supplies

NAE

3.2.1 Means of connection

P

For safe and reliable connection to an AC MAINS SUPPLY, equipment shall be provided with one of the following:

NAE

- terminals for permanent connection to the supply;
- a NON-DETACHABLE POWER SUPPLY CORD for permanent connection to the supply, or for connection to the supply by means of a plug;

D1

NOTE – In the United Kingdom, it is required to fit a plug conforming to BS 1363 to the power supply cord of certain equipment.

- an appliance inlet for connection of a DETACHABLE POWER SUPPLY CORD;
- a mains plug that is part of DIRECT PLUG-IN EQUIPMENT.

Where equipment is intended to be connected to a standard U.S. or Canadian source of supply by a power supply cord, the attachment plug shall be rated not less than 125 % of the RATED CURRENT of the equipment at the nominal system voltage range as defined by the configuration of the plug.

D1
D1
D1
D1

Compliance is checked by inspection.

3.2.2 Multiple supply connections

If equipment is provided with more than one supply connection (e.g. with different voltages or frequencies or as backup power), the design shall be such that all of the following conditions are met:

- separate means of connection are provided for different circuits; and
- supply plug connections, if any, are not interchangeable if a hazard could be created by incorrect plugging; and
- bare parts of an ELV CIRCUIT or parts at HAZARDOUS VOLTAGES, such as plug contacts, are not accessible to an OPERATOR when one or more connectors are disconnected.

Compliance is checked by inspection and for accessibility, where necessary, by a test with the test finger, of figure 2A (see 2.1.1.1).

3.2.3 Permanently connected equipment

**NAA
NAE**

PERMANENTLY CONNECTED EQUIPMENT shall be provided with either:

DE

- a set of terminals as specified in 3.3, or
- ~~a NON-DETACHABLE POWER SUPPLY CORD.~~

D1
D1

PERMANENTLY CONNECTED EQUIPMENT ~~having a set of terminals~~ shall:

D1

- permit the connection of the supply wires after the equipment has been fixed to its support; and
- be provided with cable entries, conduit entries, knock-outs or glands, which allow connection of the appropriate types of cables or conduits.

For equipment having a RATED CURRENT not exceeding 16 A, the cable entries shall be suitable for cables and conduits having an overall diameter as shown in table 3A.

NOTE 1 – In some countries the sizes of conduit in parentheses are required.

NOTE 2 – In Australia, additional requirements apply.

Conduit and cable entries and knock-outs for supply connections shall be so designed or located that the introduction of the conduit and cable does not affect the protection against electric shock, or reduce CLEARANCES and CREEPAGE DISTANCES below the values specified in 2.10.

Compliance is checked by inspection, by a practical installation test and by measurement.

Table 3A – Sizes of cables and conduits for equipment having a rated current not exceeding 16 A

Numbers of conductors, including the PROTECTIVE EARTHING CONDUCTOR where provided	Overall diameter (mm)	
	Cable	Conduit
2	13,0	16,0 (23,0)
3	14,0	16,0 (23,0)
4	14,5	20,0 (29,0)
5	15,5	20,0 (29,0)

3.2.4 Appliance inlets

Appliance inlets shall meet all of the following:

- be so located or enclosed that parts at HAZARDOUS VOLTAGE are not accessible during insertion or removal of the connector (appliance inlets complying with IEC 60309 or with IEC 60320 are considered to comply with this requirement); and
- be so located that the connector can be inserted without difficulty; and
- be so located that, after insertion of the connector, the equipment is not supported by the connector for any position of normal use on a flat surface.

Compliance is checked by inspection and, for accessibility, by means of the test finger, figure 2A (see 2.1.1.1).

3.2.5 Power supply cords

**P
NAE**

A power supply cord for connection to the AC MAINS SUPPLY shall comply with all of the following, as appropriate:

- if rubber insulated, be of synthetic rubber and not lighter than ordinary tough rubber-sheathed flexible cord according to IEC 60245 (designation 60245 IEC 53); and
- if PVC insulated:
 - for equipment provided with a NON-DETACHABLE POWER SUPPLY CORD and having a mass not exceeding 3 kg, be not lighter than light PVC sheathed flexible cord according to IEC 60227 (designation 60227 IEC 52);
 - for equipment provided with a NON-DETACHABLE POWER SUPPLY CORD and having a mass exceeding 3 kg, be not lighter than ordinary PVC sheathed flexible cord IEC 60227 (designation 60227 IEC 53);
 - for equipment provided with a DETACHABLE POWER SUPPLY CORD, be not lighter than light PVC sheathed flexible cord IEC 60227 (designation 60227 IEC 52); and

NOTE 1 – There is no limit on the mass of the equipment if the equipment is intended for use with a DETACHABLE POWER SUPPLY CORD.

- include, for equipment required to have protective earthing, a PROTECTIVE EARTHING CONDUCTOR having green-and-yellow insulation; and
- have conductors with cross-sectional areas not less than those specified in table 3B.

NOTE 2 – In Australia, additional requirements apply.

Compliance is checked by inspection and by measurement. In addition, for screened cords, compliance is checked by the tests of IEC 60227. However, flexing tests need be applied only to screened power supply cords for MOVABLE EQUIPMENT.

NOTE 3 – Although screened cords are not covered in the scope of IEC 60227, the relevant tests of IEC 60227 are used.

Damage to the screen is acceptable provided that:

- *during the flexing test the screen does not make contact with any conductor; and*
- *after the flexing test, the sample withstands the electric strength test between the screen and all other conductors.*

Table 3B – Sizes of conductors

RATED CURRENT of equipment A			Minimum conductor sizes	
			Nominal cross-sectional area mm ²	AWG or kcmil [cross-sectional area in mm ²] see note 2
	Up to and including	6	0,75 ¹⁾	18 [0,8]
Over	6 up to and including	10	(0,75) ²⁾	16 [1,3]
Over	10 up to and including	13	(1,0) ³⁾	16 [1,3]
Over	13 up to and including	16	(1,0) ³⁾	14 [2]
Over	16 up to and including	25	2,5	12 [3]
Over	25 up to and including	32	4	10 [5]
Over	32 up to and including	40	6	8 [8]
Over	40 up to and including	63	10	6 [13]
Over	63 up to and including	80	16	4 [21]
Over	80 up to and including	100	25	2 [33]
Over	100 up to and including	125	35	1 [42]
Over	125 up to and including	160	50	0 [53]
Over	160 up to and including	190	70	000 [85]
Over	190 up to and including	230	95	0000 [107]
Over	230 up to and including	260	120	250 kcmil [126]
Over	260 up to and including	300	150	300 kcmil [152]
Over	300 up to and including	340	185	400 kcmil [202]
Over	340 up to and including	400	240	500 kcmil [253]
Over	400 up to and including	460	300	600 kcmil [304]

1) For RATED CURRENT up to 3 A , a nominal cross-sectional area of 0,5 mm² is permitted in some countries provided the length of cord does not exceed 2 m.

Table 3B – Sizes of conductors Continued

RATED CURRENT of equipment A	Minimum conductor sizes	
	Nominal cross-sectional area mm ²	AWG or kcmil [cross- sectional area in mm ²] see note 2
2) The value in parentheses applies to DETACHABLE POWER SUPPLY CORDS fitted with the connectors rated 10 A in accordance with IEC 60320 (types C13, C15, C15A, and C17) provided that the length of the cord does not exceed 2 m.		
3) The value in parentheses applies to DETACHABLE POWER SUPPLY CORDS fitted with the connectors rated 16 A in accordance with IEC 60320 (types C19, C21, and C23) provided that the length of the cord does not exceed 2 m.		
NOTE 1 – IEC 60320 specifies acceptable combinations of appliance couplers and flexible cords, including those covered by items 1), 2), and 3). However, a number of countries have indicated that they do not accept all of the values listed in table 3B, particularly those covered by conditions 1), 2), and 3).		
NOTE 2 – AWG and kcmil sizes are provided for information only. The associated cross-sectional areas, in square brackets, have been rounded to show significant figures only. AWG refers to the American Wire Gage and the term "cmil" refers to circular mils where one circular mil is equal to the area of a circle having a diameter of one mil (one thousandth of an inch). These terms are commonly used to designate wire sizes in North America.		

3.2.6 Cord anchorages and strain relief

For equipment with a NON-DETACHABLE POWER SUPPLY CORD, a cord anchorage shall be supplied such that:

- the connecting points of the cord conductors are relieved from strain; and
- the outer covering of the cord is protected from abrasion.

It shall not be possible to push the cord back into the equipment to such an extent that the cord or its conductors, or both, could be damaged or internal parts of the equipment could be displaced.

For NON-DETACHABLE POWER SUPPLY CORDS containing a PROTECTIVE EARTHING CONDUCTOR, the construction shall be such that if the cord should slip in its anchorage, placing a strain on conductors, the PROTECTIVE EARTHING CONDUCTOR will be the last to take the strain.

The cord anchorage shall either be made of insulating material or have a lining of insulating material complying with the requirements for SUPPLEMENTARY INSULATION. However, where the cord anchorage is a bushing that includes the electrical connection to the screen of a screened power cord, this requirement shall not apply. The construction of the cord anchorage shall be such that:

- cord replacement does not impair the safety of the equipment; and
- for ordinary replacement cords, it is clear how relief from strain is to be obtained; and
- the cord is not clamped by a screw which bears directly on the cord, unless the cord anchorage, including the screw, is made of insulating material and the screw is of comparable size to the diameter of the cord being clamped; and
- methods such as tying the cord into a knot or tying the cord with a string are not used; and

- the cord cannot rotate in relation to the body of the equipment to such an extent that mechanical strain is imposed on the electrical connections.

INTERCONNECTING CABLES shall be provided with strain relief unless strain relief is provided as part of the equipment. Where disconnection or breaking of wiring at the connections will not result in a hazard, strain relief need not be provided, for example, in a limited power circuit where breaking of a connection will not result in a reduction of CREEPAGE DISTANCE OR CLEARANCE. D1
D1
D1
D1

Compliance is checked by inspection and by applying the following tests which are made with the type of power supply cord supplied with the equipment.

The cord is subjected to a steady pull of the value shown in table 3C, applied in the most unfavourable direction. The test is conducted 25 times, each time for a duration of 1 s.

During the tests, the power supply cord shall not be damaged. This is checked by visual inspection, and by an electric strength test between the power cord conductors and accessible conductive parts, at the test voltage appropriate for REINFORCED INSULATION.

After the tests, the power supply cord shall not have been longitudinally displaced by more than 2 mm nor shall there be appreciable strain at the connections, and CLEARANCES and CREEPAGE DISTANCES shall not be reduced below the values specified in 2.10.

Table 3C – Physical tests on power supply cords

Mass (M) of the equipment kg	Pull N
M ≤ 1	30
1 < M ≤ 4	60
M > 4	100

3.2.7 Protection against mechanical damage

Power supply cords shall not be exposed to sharp points or cutting edges within or on the surface of the equipment, or at the inlet opening or inlet bushing.

The overall sheath of a NON-DETACHABLE POWER SUPPLY CORD shall continue into the equipment through any inlet bushing or cord guard and shall extend by at least half the cord diameter beyond the clamp of the cord anchorage.

Inlet bushings, where used, shall:

- be reliably fixed; and
- not be removable without the use of a TOOL.

An inlet bushing in a non-metallic ENCLOSURE shall be of insulating material.

An inlet bushing or cord guard secured to a conductive part that is not protectively earthed shall meet the requirements for SUPPLEMENTARY INSULATION.

Compliance is checked by inspection and measurement.

3.2.8 Cord guards

A cord guard shall be provided at the power supply cord inlet opening of equipment which has a NON-DETACHABLE POWER SUPPLY CORD, and which is hand-held or intended to be moved while in operation. Alternatively, the inlet or bushing shall be provided with a smoothly rounded bell-mouthed opening having a radius of curvature equal to at least 1,5 times the overall diameter of the cord with the largest cross-sectional area to be connected.

Cord guards shall:

- be so designed as to protect the cord against excessive bending where it enters the equipment; and
- be of insulating material; and
- be fixed in a reliable manner; and
- project outside the equipment beyond the inlet opening for a distance of at least five times the overall diameter or, for flat cords, at least five times the major overall cross-sectional dimension of the cord.

Compliance is checked by inspection, by measurement and, where necessary, by the following test with the cord as delivered with the equipment.

The equipment is so placed that the axis of the cord guard, where the cord leaves it, projects at an angle of 45° when the cord is free from stress. A mass equal to $10 \times D^2g$ is then attached to the free end of the cord, where D is the overall diameter of, or for flat cords, the minor overall dimension of the cord, in millimetres.

If the cord guard is of temperature-sensitive material, the test is made at $23 \text{ °C} \pm 2 \text{ °C}$.

Flat cords are bent in the plane of least resistance.

Immediately after the mass has been attached, the radius of curvature of the cord shall nowhere be less than 1,5 D .

3.2.9 Supply wiring space

NAE

The supply wiring space provided inside, or as part of, the equipment for permanent connection or for connection of ordinary NON-DETACHABLE POWER SUPPLY CORDS shall be designed:

- to allow the conductors to be introduced and connected easily; and
- so that the uninsulated end of a conductor is unlikely to become free from its terminal, or, should it do so, cannot come into contact with:
 - an accessible conductive part that is not protectively earthed; or
 - an accessible conductive part of HAND-HELD EQUIPMENT; and
- to permit checking before fitting the cover, if any, that the conductors are correctly connected and positioned; and
- so that covers, if any, can be fitted without risk of damage to the supply conductors or their insulation; and
- so that covers, if any, giving access to the terminals can be removed with a commonly available TOOL.

Compliance is checked by inspection and by an installation test with cords of the largest cross-sectional area of the appropriate range specified in 3.3.4.

3.3 Wiring terminals for connection of external conductors

**P
NAE**

Subclause 3.3 specifies requirements for wiring terminals used for the connection of AC MAINS SUPPLY CONDUCTORS and the PROTECTIVE EARTHING CONDUCTOR to the equipment.

3.3.1 Wiring terminals

NAE

PERMANENTLY CONNECTED EQUIPMENT and equipment with ordinary NON-DETACHABLE POWER SUPPLY CORDS shall be provided with terminals in which connection is made by means of screws, nuts or equally effective devices (see also 2.6.4).

Compliance is checked by inspection.

3.3.2 Connection of non-detachable power supply cords

For equipment with special NON-DETACHABLE POWER SUPPLY CORDS, the connection of the individual conductors to the internal wiring of the equipment shall be accomplished by any means that will provide a reliable electrical and mechanical connection without exceeding the permitted temperature limits while the equipment is operated under NORMAL LOAD. (See also 3.1.9).

Compliance is checked by inspection and by measuring the temperature rise of the connection which shall not exceed the values of 4.5.1.

3.3.3 Screw terminals

NAE

Screws and nuts which clamp external power supply conductors shall have a thread conforming with ISO 261 or ISO 262, or a thread comparable in pitch and mechanical strength (e.g. unified threads). The screws and nuts shall not serve to fix any other component, except that they are permitted also to clamp internal conductors provided that the internal conductors are so arranged that they are unlikely to be displaced when fitting the supply conductors. For protective earthing terminals, see also 2.6.4.1.

The terminals of a component (e.g. a switch) built into the equipment are permitted for use as terminals for external power supply conductors, provided that they comply with the requirements of 3.3.

Compliance is checked by inspection.

3.3.4 Conductor sizes to be connected

NAE

Terminals shall allow the connection of conductors having nominal cross-sectional areas as shown in ~~table 3D~~; in accordance with annex NAE.

D1
D1

Where heavier gauge conductors are used, the terminals shall be sized accordingly.

Compliance is checked by inspection, by measurement and by fitting cords of the smallest and largest cross-sectional areas of the appropriate range. ~~shown in table 3D~~.

D1

Table 3D – Range of conductor sizes to be accepted by terminals

D1

RATED CURRENT of equipment A	Nominal cross-sectional area					
	mm ²					
	Flexible cords			Other cables		
Up to and including 3	0,5	to	0,75	4	to	2,5
Over 3 up to and including 6	0,75	to	4	4	to	2,5
Over 6 up to and including 10	4	to	1,5	4	to	2,5
Over 10 up to and including 13	1,25	to	1,5	1,5	to	4
Over 13 up to and including 16	1,5	to	2,5	1,5	to	4
Over 16 up to and including 25	2,5	to	4	2,5	to	6
Over 25 up to and including 32	4	to	6	4	to	10
Over 32 up to and including 40	6	to	10	6	to	16
Over 40 up to and including 63	10	to	16	10	to	25

D1

D1

D1

D1

D1

D1

D1

D1

D1

D1

D1

3.3.5 Wiring terminal sizes

Wiring terminals shall comply with the minimum sizes in table 3E.

Compliance is checked by inspection and measurement.

Table 3E – Sizes of terminals for a.c. mains supply conductors and protective earthing conductors

RATED CURRENT of equipment A	Minimum nominal thread diameter	
	mm	
	Pillar type or stud type	Screw type ¹⁾
Up to and including 10	3,0	3,5
Over 10 up to and including 16	3,5	4,0
Over 16 up to and including 25	4,0	5,0
Over 25 up to and including 32	4,0	5,0
Over 32 up to and including 40	5,0	5,0
Over 40 up to and including 63	6,0	6,0

¹⁾ "Screw type" refers to a terminal that clamps the conductor under the head of a screw, with or without a washer.

3.3.6 Wiring terminal design

NAA
NAE

Wiring terminals shall be so designed that they clamp the conductor between metal surfaces with sufficient contact pressure and without damage to the conductor.

Terminals shall be so designed or located that the conductor cannot slip out when the clamping screws or nuts are tightened.

Terminals shall be provided with appropriate fixing hardware for the conductors (e.g. nuts and washers).

Terminals shall be so fixed that, when the means of clamping the conductor is tightened or loosened:

- the terminal itself does not work loose; and
- internal wiring is not subjected to stress; and
- CLEARANCES and CREEPAGE DISTANCES are not reduced below the values specified in 2.10.

Compliance is checked by inspection and measurement.

3.3.7 Grouping of wiring terminals

For ordinary NON-DETACHABLE POWER SUPPLY CORDS and for PERMANENTLY CONNECTED EQUIPMENT, all associated AC MAINS SUPPLY terminals shall be located in proximity to each other and to the main protective earthing terminal, if any.

Compliance is checked by inspection.

3.3.8 Stranded wire

NAA

The end of a stranded conductor shall not be consolidated by soft soldering at places where the conductor is subject to contact pressure unless the method of clamping is designed so as to reduce the likelihood of a bad contact due to cold flow of the solder.

Spring terminals that compensate for the cold flow are deemed to satisfy this requirement.

Preventing the clamping screws from rotating is not considered to be adequate.

Terminals shall be located, guarded or insulated so that, should a strand of a flexible conductor escape when the conductor is fitted, there is no likelihood of accidental contact between such a strand and:

- accessible conductive parts; or
- unearthed conductive parts separated from accessible conductive parts by SUPPLEMENTARY INSULATION only.

Compliance is checked by inspection and, unless a special cord is prepared in such a way as to prevent the escape of strands, by the following test.

A piece of insulation approximately 8 mm long is removed from the end of a flexible conductor having the appropriate nominal cross-sectional area. One wire of the stranded conductor is left free and the other wires are fully inserted into, and clamped in, the terminal.

Without tearing the insulation back, the free wire is bent in every possible direction, but without making sharp bends around the guard.

If the conductor is at HAZARDOUS VOLTAGE, the free wire shall not touch any conductive part which is accessible or is connected to an accessible conductive part or, in the case of DOUBLE INSULATED equipment, any conductive part which is separated from accessible conductive parts by SUPPLEMENTARY INSULATION only.

If the conductor is connected to an earthing terminal, the free wire shall not touch any part at HAZARDOUS VOLTAGE.

3.4 Disconnection from the a.c. mains supply

P

3.4.1 General requirement

A disconnect device or devices shall be provided to disconnect the equipment from the AC MAINS SUPPLY for servicing.

Compliance is checked by inspection.

3.4.2 Disconnect devices

NAE

Disconnect devices shall have a contact separation of at least 3 mm and, when incorporated in the equipment, shall be connected as closely as practicable to the incoming supply.

Functional switches are permitted to serve as disconnect devices provided that they comply with all the requirements for disconnect devices. However, these requirements do not apply to functional switches where other means of isolation are provided.

The following types of disconnect devices are permitted:

- the plug on the power supply cord;
- a mains plug that is part of DIRECT PLUG-IN EQUIPMENT;
- an appliance coupler;
- isolating switches;
- circuit breakers;
- any equivalent device.

NOTE – Some disconnect devices complying with IEC 61058-1 are examples of those considered to comply with the requirements of this standard.

Compliance is checked by inspection.

3.4.3 Permanently connected equipment

For PERMANENTLY CONNECTED EQUIPMENT the disconnect device shall be incorporated in the equipment, unless the equipment is accompanied by installation instructions in accordance with 1.7.2, stating that an appropriate disconnect device shall be provided as part of the building installation.

NOTE – External disconnect devices will not necessarily be supplied with the equipment.

Compliance is checked by inspection.

3.4.4 Parts which remain energized

Parts on the supply side of a disconnect device in the equipment, which remain energized when the disconnect device is switched off, shall be guarded so as to reduce the likelihood of accidental contact by SERVICE PERSONNEL.

Compliance is checked by inspection.

3.4.5 Switches in flexible cords

Isolating switches shall not be fitted in flexible cords.

Compliance is checked by inspection.

3.4.6 Single-phase equipment

For single-phase equipment, the disconnect device shall disconnect both poles simultaneously, except that a single-pole disconnect device can be used to disconnect the line conductor where it is possible to rely on the identification of the neutral in the AC MAINS SUPPLY.

For equipment provided with a single-pole disconnect device, the installation instructions shall specify that an additional two-pole disconnect device is to be provided in the building installation if the equipment is used where identification of the neutral in the AC MAINS SUPPLY is not possible.

NOTE – Three examples of cases where a two-pole disconnect device is required are:

- on equipment supplied from an IT power system;
- on PLUGGABLE EQUIPMENT supplied through a reversible appliance coupler or a reversible plug (unless the appliance coupler or plug itself is used as the disconnect device);
- on equipment supplied from a socket-outlet with indeterminate polarity.

Compliance is checked by inspection.

3.4.7 Three-phase equipment

For three-phase equipment, the disconnect device shall disconnect simultaneously all line conductors of the AC MAINS SUPPLY.

For equipment requiring a neutral connection to an IT power system, the disconnect device shall be a four-pole device and shall disconnect all line conductors and the neutral conductor. If this four-pole device is not provided in the equipment, the installation instructions shall specify the need for the provision of the device as part of the building installation.

If a disconnect device interrupts the neutral conductor, it shall simultaneously interrupt all line conductors.

Compliance is checked by inspection.

3.4.8 Switches as disconnect devices

NAE

Where the disconnect device is a switch incorporated in the equipment, its "ON" and "OFF" positions shall be marked in accordance with 1.7.8.

Compliance is checked by inspection.

3.4.9 Plugs as disconnect devices

Where a plug on the power supply cord is used as the disconnect device, the installation instructions shall comply with 1.7.2.

Compliance is checked by inspection.

3.4.10 Interconnected equipment

NAE

Where a group of units having individual supply connections is interconnected in such a way that it is possible for HAZARDOUS VOLTAGE OR HAZARDOUS ENERGY LEVELS to be transmitted between units, a disconnect device shall be provided to disconnect hazardous parts likely to be contacted while the unit under consideration is being serviced, unless these parts are guarded and marked with appropriate warning labels. In addition a prominent label shall be provided on each unit giving adequate instructions for the removal of all such power from the unit.

Compliance is checked by inspection.

3.4.11 Multiple power sources

Where a unit receives power from more than one source (e.g. different voltages or frequencies or as backup power), there shall be a prominent marking at each disconnect device giving adequate instructions for the removal of all power from the unit.

Compliance is checked by inspection.

3.5 Interconnection of equipment

3.5.1 General requirements

Where equipment is intended to be electrically connected to other equipment, interconnection circuits shall be selected to provide continued conformance to the requirements of 2.2 for SELV CIRCUITS, and with the requirements of clause 2.3 for TNV CIRCUITS, after making connections.

NOTE 1 – This is normally achieved by connecting SELV CIRCUITS to SELV CIRCUITS, and TNV CIRCUITS to TNV CIRCUITS.

NOTE 2 – It is permitted for an INTERCONNECTING CABLE to carry more than one type of CIRCUIT (e.g. SELV, LIMITED CURRENT, TNV, ELV OR HAZARDOUS VOLTAGE) provided that they are separated as required by this standard.

3.5.2 Types of interconnection circuits

Each interconnection circuit shall be one of the following types:

- an SELV CIRCUIT OR a LIMITED CURRENT CIRCUIT; OR
- a TNV-1, TNV-2 OR TNV-3; OR
- a HAZARDOUS VOLTAGE circuit.

Except as permitted in 3.5.3, interconnection circuits shall not be ELV CIRCUITS.

Compliance is checked by inspection.

3.5.3 ELV circuits as interconnection circuits

NAE

Where additional equipment is specifically complementary to the host (first) equipment (e.g. a collator for a copying machine) ELV CIRCUITS are permitted as interconnection circuits between the equipments, provided that the equipments continue to meet the requirements of this standard when connected together.

Compliance is checked by inspection.

3.6 Special considerations for equipment connected to a centralized d.c. power system – DC mains voltages

D2 **NAA**
 D2 **NAB**
NAE

DC mains voltages are considered SECONDARY CIRCUITS and are characterized as either SELV CIRCUITS OR HAZARDOUS VOLTAGE circuits depending on the maximum operating voltage (including the "float voltage") of the source.

D2
 D2
 D2

For the purpose of applying insulation requirements, d.c. mains voltages are treated as:

D2

- SELV CIRCUIT up to 60 V
- TNV 2 CIRCUIT > 60 V up to and including 80 V
- HAZARDOUS VOLTAGE > 80 V

D2
 D2
 D2

These circuits are not current limited to TNV CIRCUIT limits when providing power for centralized d.c. equipment but shall be appropriately current limited when connected to a TELECOMMUNICATION NETWORK.

D2
 D2
 D2

See annex NAB for additional requirements that apply to centralized d.c. power systems.

D2 **NAB**

4 Physical requirements

4.1 Stability

4.1.1 Under conditions of normal use, units and equipment shall not become physically unstable to the degree that they could become a hazard to OPERATORS and SERVICE PERSONNEL.

NAA

If units are designed to be fixed together on site and not used individually, the stability of each individual unit is exempt from the requirements of 4.1.

The requirements of 4.1 are not applicable when the installation instructions for a unit specify that the equipment is to be secured to the building structure before operation.

Under conditions of OPERATOR use, a stabilizing means, if needed, shall be automatic in operation when drawers, doors, etc., are opened.

During operations performed by SERVICE PERSONNEL, the stabilizing means, if needed, shall either be automatic in operation, or a marking shall be provided to instruct SERVICE PERSONNEL to deploy the stabilizing means.

Compliance is checked by the following tests, where relevant. Each test is carried out separately. During the tests, containers are to contain the amount of substance within their rated capacity producing the most disadvantageous condition. All castors and jacks, if used in normal operation, are placed in their most unfavourable position, with wheels and the like locked or blocked. However, if the castors are intended only to transport the unit, and if the installation instructions require jacks to be lowered after installation, then the jacks (and not the castors) are used in this test; the jacks are placed in their most unfavourable position, consistent with reasonable levelling of the unit.

- A unit shall not overbalance when tilted to an angle of 10 ° from its normal upright position. Doors, drawers, etc. are closed during this test.*
- A floor-standing unit having a mass of 25 kg or more shall not tip over when a force equal to 20 % of the weight of the unit, but not more than 250 N, is applied in any direction except upwards, at a height not exceeding 2 m from the floor. Doors drawers, etc. which may be moved for servicing by the OPERATOR or by SERVICE PERSONNEL, are placed in their most unfavourable position, consistent with the installation instructions.*
- A floor-standing unit shall not overbalance when a constant downward force of 800 N is applied at the point of maximum moment to any horizontal surface of at least 12,5 cm by at least 20 cm, at a height up to 1 m from the floor. Doors, drawers, etc. are closed during this test. The 800 N force is applied by means of a suitable test tool having a flat surface of approximately 12,5 cm by 20 cm. The downward force is applied with the complete flat surface of the test tool in contact with the EUT; the test tool need not be in full contact with uneven surfaces, e.g. corrugated or curved surfaces.*

4.2 Mechanical strength

P

4.2.1 General

Equipment shall have adequate mechanical strength and shall be so constructed as to remain safe in the meaning of this standard when subjected to handling as may be expected.

Mechanical strength tests are not required on an internal barrier, screen or the like, provided to meet the requirements of 4.6.2, if the ENCLOSURE provides mechanical protection.

A MECHANICAL ENCLOSURE shall be sufficiently complete to contain or deflect parts which, because of failure or for other reasons, might become loose, separated or thrown from a moving part.

Compliance is checked by inspection of the construction and available data and, where necessary, by the relevant tests of 4.2.2 to 4.2.7 as specified

The tests are not applied to handles, levers, knobs, the face of cathode ray tubes (see 4.2.8), or to transparent or translucent covers of indicating or measuring devices unless parts at HAZARDOUS VOLTAGE are accessible by means of the test finger, of figure 2A (see 2.1.1.1), if the handle, lever, knob or cover is removed.

During the tests of 4.2.2, 4.2.3 and 4.2.4, earthed or unearthed conductive ENCLOSURES shall not bridge parts between which a HAZARDOUS ENERGY LEVEL exists and shall not contact a bare part at HAZARDOUS VOLTAGE. For voltages exceeding 1 000 V a.c. or 1 500 V d.c., contact is not permitted and there shall be an air gap between the part at HAZARDOUS VOLTAGE and the ENCLOSURE. This air gap shall either have a minimum length equal to the minimum CLEARANCE specified in 2.10.3 for BASIC INSULATION or withstand the relevant electric strength test in 5.2.2.

After the tests of 4.2.2 to 4.2.7, the sample shall continue to comply with the requirements of 2.1.1, 2.6.1, 2.10, 3.2.6 and 4.4.1. It shall show no signs of interference with the operation of safety features such as THERMAL CUT-OUTS, overcurrent protection devices or interlocks. In case of doubt, SUPPLEMENTARY OR REINFORCED INSULATION is subjected to an electric strength test as specified in 5.2.2.

Damage to finish, cracks, dents and chips are disregarded if they do not adversely affect safety.

NOTE – If a separate ENCLOSURE or part of an ENCLOSURE is used for a test, it may be necessary to reassemble such parts on the equipment in order to check compliance.

4.2.2 Steady force test, 10 N

Components and parts, other than parts serving as an ENCLOSURE (see 4.2.3 and 4.2.4), are subjected to a steady force of $10\text{ N} \pm 1\text{ N}$.

Compliance criteria are in 4.2.1.

4.2.3 Steady force test, 30 N

Parts of an ENCLOSURE located in an OPERATOR ACCESS AREA, which are protected by a cover or door meeting the requirements of 4.2.4, are subjected to a steady force of $30\text{ N} \pm 3\text{ N}$ for a period of 5 s, applied by means of a straight unjointed version of the test finger, of figure 2A (see 2.1.1.1), to the part on or within the equipment.

Compliance criteria are in 4.2.1.

4.2.4 Steady force test, 250 N

External ENCLOSURES are subjected to a steady force of $250\text{ N} \pm 10\text{ N}$ for a period of 5 s, applied in turn to the top, bottom and sides of the ENCLOSURE fitted to the equipment, by means of a suitable test tool providing contact over a circular plane surface 30 mm in diameter. However, this test is not applied to the bottom of an ENCLOSURE of equipment having a mass of more than 18 kg.

Compliance criteria are in 4.2.1.

4.2.5 Impact test

Except for equipment identified in 4.2.6, external surfaces of ENCLOSURES, the failure of which would give access to hazardous parts, are tested as follows:

A sample consisting of the complete ENCLOSURE or a portion thereof representing the largest unreinforced area is supported in its normal position. A solid smooth steel ball, approximately 50 mm in diameter and with a mass of $500\text{ g} \pm 25\text{ g}$, is permitted to fall freely from rest through a vertical distance (H) of 1,3 m (see figure 4A) onto the sample. (Vertical surfaces are exempt from this test.)

In addition, the steel ball is suspended by a cord and swung as a pendulum in order to apply a horizontal impact, dropping through a vertical distance (H) of 1,3 m (see figure 4A). (Horizontal surfaces are exempt from this test). Alternatively, the sample is rotated 90° about each of its horizontal axes and the ball dropped as in the vertical impact test.

The test is not applied to flat panel displays or to the platen glass of equipment (e.g. copying machines).

Compliance criteria are in 4.2.1.

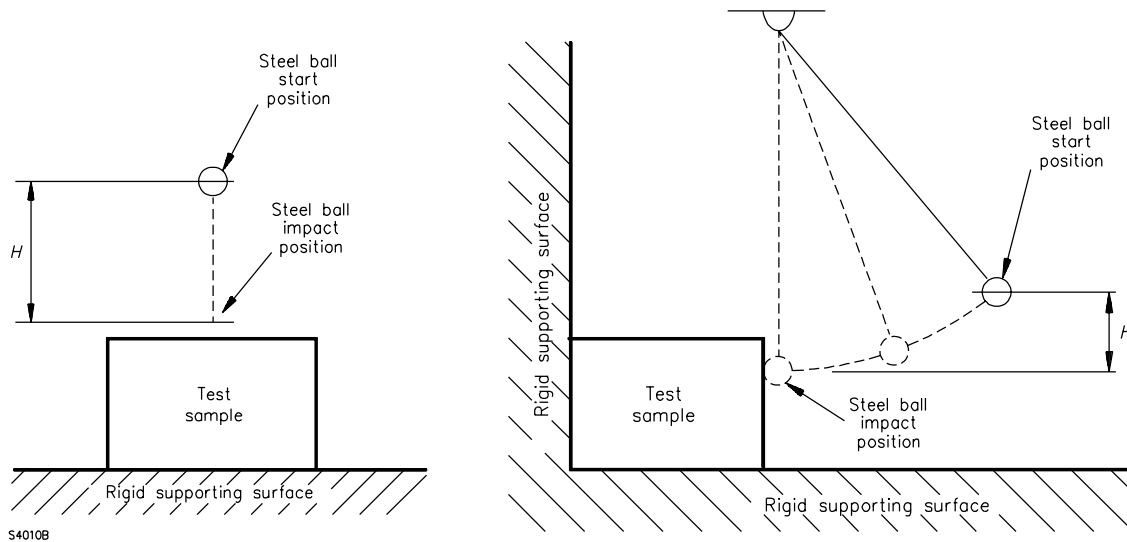

Figure 4A – Impact test using a steel ball

4.2.6 Drop test

The following equipment is subjected to a drop test:

- HAND-HELD EQUIPMENT;
- DIRECT PLUG-IN EQUIPMENT;
- TRANSPORTABLE EQUIPMENT;
- desk-top equipment having a mass of 5 kg or less that is intended for use with any one of the following:
 - a cord-connected telephone handset, or
 - another cord-connected hand-held accessory with an acoustic function, or
 - a headset.

A sample of the complete equipment is subjected to three impacts that result from being dropped onto a horizontal surface in positions likely to produce the most adverse results.

The height of the drop shall be

- 750 mm ± 10 mm for desk-top equipment as described above;

– 1 000 mm ± 10 mm for HAND-HELD EQUIPMENT, DIRECT PLUG-IN EQUIPMENT and TRANS-PORTABLE EQUIPMENT.

The horizontal surface consists of hardwood at least 13 mm thick, mounted on two layers of plywood each 19 mm to 20 mm thick, all supported on a concrete or equivalent non-resilient floor.

Compliance criteria are in 4.2.1.

4.2.7 Stress relief

ENCLOSURES of moulded or formed thermoplastic materials shall be so constructed that any shrinkage or distortion of the material due to release of internal stresses caused by the moulding or forming operation does not result in the exposure of hazardous parts or in the reduction of CREEPAGE DISTANCES OR CLEARANCES below the minimum required.

Compliance is checked by the stress relief conditioning of clause A.10 or by the inspection of the construction and the available data where appropriate.

If stress relief conditioning is conducted, the compliance criteria of 4.2.1 apply.

4.2.8 Cathode ray tubes

If cathode ray tubes having a maximum face dimension exceeding 160 mm is included in the equipment, the cathode ray tube or the equipment, or both, shall comply with the requirements of IEC 60065 for mechanical strength and protection against the effects of implosion.

Compliance is checked by inspection, by measurement and by the relevant tests of IEC 60065.

4.2.8.1 Cathode ray tube enclosure

To reduce the risk of injury that may result from implosion of a cathode ray tube having a minimum diameter of 160 mm or equivalent face area, the projected area of any opening in the top, back, sides or front of the ENCLOSURE onto a plane perpendicular to a line passing through the centre of the opening and any point on the central axis of the bulb section of the picture tube shall not exceed 129 mm² unless the minor dimension of the projected area is not more than 9.5 mm. The cathode ray tube enclosure opening is illustrated in figure 4A1.

Compliance is checked by inspection and measurement.

**P
NAD**

D2

D2

D2

D2

D2

D2

D2

D2

4.2.10 Wall or ceiling mounted equipment

The mounting means of equipment intended for wall or ceiling mounting shall be adequate.

Compliance is checked by inspection of the construction and of available data, or where necessary, by the following test.

The equipment is mounted in accordance with the manufacturer's instructions. A force in addition to the weight of the equipment is applied downwards through the geometric centre of the equipment, for 1 min. The additional force shall be equal to three times the weight of the equipment but not less than 50 N. The equipment and its associated mounting means shall remain secure during the test.

4.3 Design and construction

4.3.1 Edges and corners

Where edges or corners could be hazardous to OPERATORS because of location or application in the equipment, they shall be rounded or smoothed.

This requirement does not apply to edges or corners that are required for proper functioning of the equipment.

Compliance is checked by inspection.

4.3.2 Handles and manual controls

Handles, knobs, grips, levers and the like shall be reliably fixed so that they will not work loose in normal use, if this might result in a hazard. Sealing compounds and the like, other than self-hardening resins, shall not be used to prevent loosening.

If handles, knobs and the like are used to indicate the position of switches or similar components, it shall not be possible to fix them in a wrong position if this might result in a hazard.

Compliance is checked by inspection, by manual test and by trying to remove the handle, knob, grip or lever by applying for 1 min an axial force as follows.

If the shape of these parts is such that an axial pull is unlikely to be applied in normal use, the force is:

- 15 N for the operating means of electrical components; and*
- 20 N in other cases.*

If the shape is such that an axial pull is likely to be applied, the force is:

- 30 N for the operating means of electrical components; and*
- 50 N in other cases.*

A handle or handles intended to support more than 9.0 kg shall be capable of supporting four times the weight of the product without breakage of the handle, its securing means or that part of the product to which the handle is attached.

D2
D2
D2

Compliance is determined by applying a force in the intended carrying direction uniformly over a 75 mm length at the centre of the handle. Starting at zero, the applied force is to be gradually increased so that the required test value is attained in 5 – 10 s and then maintained at the test value for 1 min. If more than one handle is provided, the test force is to be determined by the percentage of the product weight sustained by each handle with the product in the intended carrying position. If a product weighing less than 25.0 kg is provided with more than one handle but can be carried by only one handle, each handle is to be capable of withstanding a force based on the total weight of the product.

D2
D2
D2
D2
D2
D2
D2
D2

4.3.3 Adjustable controls

Equipment shall be so constructed that manual adjustment of a control device, such as a device for selection of different AC MAINS SUPPLY voltages, requires the use of a TOOL if incorrect setting or inadvertent adjustment might create a hazard.

NOTE – Marking requirements for supply voltage adjustment are in 1.7.4.

Compliance is checked by manual test.

4.3.4 Securing of parts

P

Screws, nuts, washers, springs or similar parts shall be secured so as to withstand mechanical stresses occurring in normal use if loosening would create a hazard, or if CLEARANCES OR CREEPAGE DISTANCES OVER SUPPLEMENTARY INSULATION OR REINFORCED INSULATION would be reduced to less than the values specified in 2.10.

NOTE 1 – Requirements regarding fixing of conductors are in 3.1.9.

Compliance is checked by inspection, by measurement and by manual test.

For the purpose of assessing compliance:

- *it is assumed that two independent fixings will not become loose at the same time; and*
- *it is assumed that parts fixed by means of screws or nuts provided with self-locking washers or other means of locking are not liable to become loose.*

NOTE 2 – Spring washers and the like can provide satisfactory locking.

4.3.5 Connection of plugs and sockets

Within a manufacturer's unit of or system, plugs and sockets likely to be used by the OPERATOR or by SERVICE PERSONNEL shall not be employed in a manner likely to create a hazard due to misconnection. In particular, connectors complying with IEC 60083 or IEC 60320 shall not be used for SELV CIRCUITS or TNV CIRCUITS. Keying, location or, in the case of connectors accessible only to SERVICE PERSONNEL, clear markings are permitted to meet the requirement. DE

Compliance is checked by inspection.

4.3.6 Direct plug-in equipment

P

DIRECT PLUG-IN EQUIPMENT shall not impose undue strain on the socket-outlet. The mains plug part shall comply with the standard for the relevant mains plug.

Compliance is checked by inspection and, if necessary, by the following test:

The equipment is inserted, as in normal use, into a fixed socket-outlet of a configuration as intended by the manufacturer, which can be pivoted about a horizontal axis intersecting the centre lines of the contacts at a distance of 8 mm behind the engagement face of the socket-outlet. The additional torque which has to be applied to the socket-outlet to maintain the engagement face in the vertical plane shall not exceed 0,25 N·m.

NOTE 1 – In Australia, compliance is checked in accordance with AS/NZS 3112.

NOTE 2 – In the United Kingdom:

- the torque test is performed using a socket-outlet complying with BS 1363, with an earthing contact;
- the plug part of DIRECT PLUG-IN EQUIPMENT is assessed to BS 1363: Part 1, 12.1, 12.2, 12.3, 12.9, 12.11, 12.12, 12.16 and 12.17, except that the test in 12.17 is carried out at not less than 125 °C.

4.3.7 Heating elements in earthed equipment

Heating elements in equipment that is earthed for safety purposes shall be protected so that, under earth fault conditions, a fire hazard due to overheating is prevented. In such equipment, temperature sensing devices, if provided, shall be located in all line conductors supplying the heating elements.

The temperature sensing devices shall also disconnect the neutral conductor for each of the following cases:

- a) in equipment supplied from an IT power system;
- b) in PLUGGABLE EQUIPMENT supplied through a reversible appliance coupler or a reversible plug;
- c) in equipment supplied from a socket-outlet with indeterminate polarity.

In cases b) and c), it is permitted to meet this requirement by connecting a THERMOSTAT in one conductor and a THERMAL CUT-OUT in the other conductor.

It is not required to disconnect the conductors simultaneously.

Compliance is checked by inspection.

4.3.8 Batteries

NOTE 1 – Requirements for markings or instructions are given in 1.7.15.

Equipment containing batteries shall be designed to reduce the risk of fire, explosion and chemical leaks under normal conditions and after a single fault in the equipment (see 1.4.14), including a fault in circuitry within the equipment battery pack. For USER-replaceable batteries, the design shall reduce the likelihood of reverse polarity installation if this would create a hazard.

Battery circuits shall be designed so that:

- the output characteristics of a battery charging circuit are compatible with its rechargeable battery; and
- for non-rechargeable batteries, discharging at a rate exceeding the battery manufacturer's recommendations, and unintentional charging, are prevented; and
- for rechargeable batteries, charging and discharging at a rate exceeding the battery manufacturer's recommendations, and reversed charging, are prevented.

NOTE 2 – Reversed charging of a rechargeable battery occurs when the polarity of the charging circuit is reversed, aiding the discharge of the battery.

Compliance is checked by inspection and by evaluation of the data provided by the equipment manufacturer and battery manufacturer for charging and discharging rates.

When appropriate data is not available, compliance is checked by test. However, batteries that are inherently safe for the conditions given are not tested under those conditions. Consumer grade, non-rechargeable carbon-zinc or alkaline batteries are considered safe under short-circuiting conditions and therefore are not tested for discharge; nor are such batteries tested for leakage under storage conditions.

A new non-rechargeable battery or fully charged rechargeable battery provided with, or recommended by the manufacturer for use with, the equipment shall be used for each of the following tests:

- *for evaluating the overcharging of a rechargeable battery, a battery is charged for a period of 7 h under each of the following conditions in turn:*
 - *with the battery charging circuit adjusted for its maximum charging rate (if such an adjustment exists); followed by*
 - *any single component failure that is likely to occur in the charging circuit and which would result in overcharging of the battery; and*
- *for evaluating the unintentional charging of a non-rechargeable battery, a battery is charged for 7 h with any single component failure that is likely to occur and which would result in unintentional charging of the battery; and*

- for evaluating the reversed charging of a rechargeable battery, a battery is charged for 7 h with any single component failure that is likely to occur and which would result in reversed charging of the battery; and
- for evaluating an excessive discharging rate for any battery, a battery is subjected to rapid discharge by open-circuiting or short-circuiting any current-limiting or voltage-limiting components in the load circuit of the battery under test.

NOTE 3 – Some of the tests specified can be hazardous to the persons carrying them out; all appropriate measures to protect personnel against possible chemical or explosive hazards should be taken.

These tests shall not result in any of the following:

- chemical leaks caused by cracking, rupturing or bursting of the battery jacket, if such leakage could adversely affect required insulation; or
- explosion of the battery, if such explosion could result in injury to a USER; or
- emission of flame or expulsion of molten metal to the outside of the equipment ENCLOSURE.

After completion of the tests, the equipment shall be subjected to the electric strength tests of 5.3.8.2.

4.3.9 Oil and grease

Where internal wiring, windings, commutators, slip-rings and the like, and insulation in general, are exposed to oil, grease or similar substances, the insulation shall have adequate properties to resist deterioration under these conditions.

Compliance is checked by inspection, and by evaluation of the data for the insulating material.

4.3.10 Dust, powders, liquids and gases

NAD

Equipment producing dust (e.g. paper dust) or using powders, liquids or gases shall be so constructed that no dangerous concentration of these materials can exist and that no hazard in the meaning of this standard is created by condensation, vaporization, leakage, spillage or corrosion during normal operation, storage, filling or emptying. In particular, CREEPAGE DISTANCES and CLEARANCES shall not be reduced below the requirements of 2.10.

Compliance is checked by inspection, measurement and, where spillage of liquid could affect electrical insulation during replenishment, by the following test and, for flammable liquids, by the tests of 4.3.12.

The equipment shall be ready to use according to its installation instructions, but not energized.

The liquid container of the equipment is completely filled with the liquid specified by the manufacturer and a further quantity, equal to 15 % of the capacity of the container is poured in steadily over a period of 1 min. For liquid containers having a capacity not exceeding 250 ml, and for containers without drainage and for which the filling cannot be observed from outside, a further quantity of liquid, equal to the capacity of the container, is poured in steadily over a period of 1 min.

Immediately after this treatment, the equipment shall withstand an electric strength test as specified in 5.2.2 on any insulation on which spillage could have occurred and inspection shall show that the liquid has not created a hazard in the meaning of this standard.

The equipment is permitted to stand in normal test-room atmosphere for at least 24 h before being subjected to any further electrical test.

4.3.11 Containers for liquids or gases

Equipment that, in normal use, contains liquids or gases shall incorporate adequate safeguards against build-up of excessive pressure.

Compliance is checked by inspection and, if necessary, by an appropriate test.

4.3.12 Flammable liquids

If a flammable liquid is used in equipment, the liquid shall be kept in a closed reservoir, except for the amount needed for the functioning of the equipment. The maximum quantity of flammable liquid stored in an equipment shall in general be not more than 5 l. If, however, the usage of liquid is such that more than 5 l is consumed in 8 h, the quantity stored is permitted to be increased to that required for an 8 h operation.

Oil or equivalent liquids used for lubrication or in a hydraulic system shall have a flash point of 149 °C or higher, and the reservoir shall be of sealed construction. The system shall have provision for expansion of the liquid and shall incorporate means for pressure relief. This requirement is not applicable to lubricating oils which are applied to points of friction in quantities which would contribute negligible fuel to a fire.

Except under conditions given below, replenishable liquids such as printing inks shall have a flash point of 60 °C or higher, and shall not be under sufficient pressure to cause atomisation.

Replenishable flammable liquids which have a flash point of less than 60 °C or which are under sufficient pressure to cause atomisation are permitted provided inspection shows that there is no likelihood of liquid sprays or build-up of flammable vapour-air mixtures which could cause explosion or fire hazard. Under normal operating conditions, equipment using a flammable liquid shall not generate a mixture with a concentration exceeding one quarter of the EXPLOSION LIMIT if the mixture is in proximity to an ignition source, or exceeding half the EXPLOSION LIMIT if the mixture is not in proximity to an ignition source. The investigation shall also take into account the integrity of the liquid handling system. The liquid handling system shall be suitably housed or constructed so as to avoid the risk of fire or explosion, even under the test conditions specified in 4.2.5.

Compliance is checked by inspection and, where necessary, by the following test:

The equipment is operated in accordance with 4.5.1 until its temperature stabilizes. In this condition, the equipment is operated in a normal manner, as directed in the operating instructions, and samples of the atmosphere in the vicinity of the electrical components and around the equipment are taken to determine the concentration of flammable vapours present.

Samples of the atmosphere are taken at 4 min intervals; four samples to be taken during normal operation, then seven samples after the equipment has stopped.

P
NAA
NAD
NAE

If, after the equipment has stopped, the concentration of flammable vapours appears to be increasing, samples shall continue to be taken at 4 min intervals until the concentration is shown to be decreasing.

If an abnormal operation of the equipment is possible with any of its fans not running, this condition is simulated during this compliance test.

4.3.13 Radiation

Equipment that can generate ionizing radiation or ultraviolet light, or that uses a laser, or in which similar hazards are present, shall be so designed that harmful effects to persons and damage to materials affecting safety are prevented.

For ionizing radiation compliance is checked by the test in annex H.

For equipment using lasers, compliance is checked according to IEC 60825-1 annex NAE.

D1

For other types of radiation, compliance is checked by inspection.

NOTE – Requirements for ultraviolet light are under consideration.

4.4 Protection against hazardous moving parts

4.4.1 General

Hazardous moving parts of equipment, i.e. moving parts which have the potential to cause injury, shall be so arranged, enclosed or guarded as to provide adequate protection against the risk of personal injury.

AUTOMATIC RESET THERMAL CUT-OUTS OR overcurrent protection devices, automatic timer starting, etc., shall not be incorporated if unexpected resetting might create a hazard.

Compliance is checked by inspection and as detailed in 4.4.2, 4.4.3 and 4.4.4.

4.4.2 Protection in operator access areas

In an OPERATOR ACCESS AREA, protection shall be provided by a suitable construction reducing the likelihood of access to hazardous moving parts, or by locating the moving parts in an ENCLOSURE provided with mechanical or electrical SAFETY INTERLOCKS that remove the hazard when access is gained.

Where it is not possible to comply fully with the above access requirements and also allow the equipment to function as intended, access is permitted provided that:

- the hazardous moving part concerned is directly involved in the process (e.g. moving parts of a paper cutter); and
- the hazard associated with the part is obvious to the OPERATOR; and
- additional measures are taken as follows:

H
NAA
NAE

- a statement shall be provided in the operating instructions and a marking shall be fixed to the equipment, each containing the following or a similar appropriate wording:

WARNING

HAZARDOUS MOVING PARTS

KEEP FINGERS AND OTHER BODY PARTS AWAY

- where the possibility exists that fingers, jewellery, clothing, etc., can be drawn into the moving parts, means shall be provided to enable the operator to stop the moving part.

The above warning notice and, where relevant, the means provided for stopping the moving part shall be placed in a prominent position, readily visible and accessible from the point where the risk of injury is greatest.

Compliance is checked by inspection and where necessary by a test with the test finger, of figure 2A (see 2.1.1.1), after removal of OPERATOR-detachable parts, and with OPERATOR access doors and covers open.

Unless additional measures have been taken as specified above, it shall not be possible to touch hazardous moving parts with the test finger, applied without appreciable force in every possible position.

Openings preventing the entry of the test finger, of figure 2A (see 2.1.1.1) are further tested by means of a straight unjointed version of the test finger applied with a force of 30 N. If the unjointed finger enters, the test with the test finger, of figure 2A (see 2.1.1.1) is repeated, except that the finger is pushed through the opening using any necessary force up to 30 N.

4.4.3 Protection in restricted access locations

For equipment to be installed in a RESTRICTED ACCESS LOCATION, the requirements and compliance criteria in 4.4.2 for OPERATOR ACCESS AREAS apply.

4.4.4 Protection in service access areas

In a SERVICE ACCESS AREA, protection shall be provided such that unintentional contact with hazardous moving parts is unlikely during servicing operations involving other parts of the equipment.

Compliance is checked by inspection.

4.5 Thermal requirements

Subclause 4.5 specifies requirements intended to prevent:

- touchable parts from exceeding certain temperatures; and
- components, parts, insulation and plastic materials from exceeding temperatures which may degrade electrical, mechanical, or other properties during normal use over the expected life of the equipment.

Consideration shall be given to the fact that, on a long term basis, the electrical and mechanical properties of certain insulating materials may be adversely affected (e.g. by softeners evaporating at temperatures below the normal softening temperatures of the materials), see 2.9.1.

4.5.1 Temperature rises

Materials used in components and in the construction of the equipment shall be selected such that under NORMAL LOAD operation, temperatures do not exceed safe values in the meaning of this standard.

Components working at high temperature shall be effectively shielded or separated to avoid overheating of their adjacent materials and components.

Compliance is checked by inspection of material data sheets and by determining and recording the temperature rises in accordance with 1.4.12 and 1.4.13.

Taking into account the requirements of 1.4.5, the equipment or parts of the equipment are operated under NORMAL LOAD as follows:

- *for CONTINUOUS OPERATION, until steady conditions are established; and*
- *for INTERMITTENT OPERATION, until steady conditions are established, using the rated "ON" and "OFF" periods; and*
- *for SHORT-TIME OPERATION, for the RATED OPERATING TIME.*

It is permitted to test components and other parts independently provided that the test conditions applicable to the equipment are followed.

Equipment intended for building-in or rack-mounting, or for incorporation in larger equipment, is tested under the most adverse actual or simulated conditions permitted in the installation instructions.

**E L
P
NAE**

The temperature rise of electrical insulation (other than that of windings, see 1.4.13) the failure of which could create a hazard, is measured on the surface of the insulation at a point close to the heat source, see item 1) of table 4A. During the test:

- THERMAL CUT-OUTS and overcurrent protection devices shall not operate;
- THERMOSTATS are permitted to operate, provided that they do not interrupt the normal operation of the equipment;
- TEMPERATURE LIMITERS are permitted to operate;
- sealing compounds, if any, shall not flow out.

The temperature rises shall not exceed the values shown in table 4A, parts 1 and 2.

**Table 4A – Temperature rise limits
Part 1**

Part	Maximum temperature rise K
Insulation, including winding insulation:	
– of Class A material	75 ^{1), 2), 5)}
– of Class E material	90 ^{1), 2), 5)}
– of Class B material	95 ^{1), 2), 5)}
– of Class F material	115 ^{1), 2), 5)}
– of Class H material	140 ^{1), 2), 5)}
Synthetic rubber or PVC insulation of internal and external wiring, including power supply cords:	
– without T-marking	50
– with T-marking	T – 25
Other thermoplastic insulation	3)
Terminals, including earthing terminals for external earthing conductors of STATIONARY EQUIPMENT, unless provided with a NON-DETACHABLE POWER SUPPLY CORD	60
Parts in contact with a flammable liquid	See 4.3.12
Components	See 1.5.1

Temperature rise limits Part 2

Parts in OPERATOR ACCESS AREAS	Maximum temperature rise K		
	Metal	Glass, porcelain and vitreous material	Plastic and rubber ⁵⁾
Handles, knobs, grips, etc., held or touched for short periods only	35	45	60
Handles, knobs, grips, etc., continuously held in normal use	30	40	50
External surfaces of equipment which may be touched ⁴⁾	45	55	70
Parts inside the equipment which may be touched ⁶⁾	45	55	70

Table 4A (part one and part two)

1) If temperature rises of windings are determined by thermocouples, these figures are reduced by 10 K, except in the case of motors.

2) The classification of insulating materials (Classes A, E, B, F and H) is in accordance with IEC 60085.

3) Due to their wide variety, it is not possible to specify permitted temperature rises for thermoplastic materials. These shall pass the tests specified in 4.5.2.

4) For areas on the external surface of equipment and having no dimension exceeding 50 mm, and which are not likely to be touched in normal use, temperature rises up to 75 K are permitted.

5) For each material, account shall be taken of the data for that material to determine the appropriate maximum temperature rise.

6) Temperature rises exceeding the limits are permitted provided that the following conditions are met:

- unintentional contact with such a part is unlikely;
- the part has a marking indicating that this part is hot. It is permitted to use the symbol \blacktriangle (60417-2-IEC-5041) to provide this information.

For equipment intended for installation in a RESTRICTED ACCESS LOCATION, the temperature rise limits in table 4A, parts 1 and 2, apply, except that for external metal parts which are evidently designed as heat sinks or which have a visible warning, a temperature rise of 65 K is permitted.

4.5.2 Resistance to abnormal heat

Thermoplastic parts on which parts at HAZARDOUS VOLTAGE are directly mounted shall be resistant to abnormal heat.

Compliance is checked by subjecting the part to the ball-pressure test according to IEC 60695-10-2. The test is not made if it is clear from examination of the physical characteristics of the material that it will meet the requirements of this test.

The test is made in a heating cabinet at a temperature which is $40\text{ K} \pm 2\text{ K}$ greater than the maximum temperature rise of the part determined during the test of 4.5.1. However, a thermoplastic part supporting parts in a PRIMARY CIRCUIT is tested at a minimum of 125 °C.

4.6 Openings in enclosures

For equipment that is intended to be used in more than one orientation (see 1.3.6), the requirements of 4.6.1 and 4.6.2 apply in each appropriate orientation.

NOTE – Additional requirements concerning openings in ENCLOSURES are in 2.1.1.

4.6.1 Top and side openings

Openings in the top and sides of ENCLOSURES, except for ENCLOSURES of TRANSPORTABLE EQUIPMENT (see 4.6.4), shall be so located or constructed that it is unlikely that objects will enter the openings and create hazards by contacting bare conductive parts.

NOTE 1 – Hazards include energy hazards, and those created by bridging of insulation or by OPERATOR access to parts at HAZARDOUS VOLTAGE (e.g. via metal jewellery).

Openings, located behind doors, panels, covers, etc., that can be opened or removed by an operator, are not required to comply provided that the equipment openings comply with the doors, panels and covers closed or in place.

Where a portion of the side of a FIRE ENCLOSURE falls within the area traced out by the 5° angle in figure 4E, the limitations in 4.6.2 on sizes of openings in bottoms of FIRE ENCLOSURES also apply to this portion of the side.

Compliance is checked by inspection and measurement. Except for that portion of the side of a FIRE ENCLOSURE that is subject to the requirements of 4.6.2 (see above paragraph), any one of the following is considered to satisfy the requirements (other constructions are not excluded):

- openings that do not exceed 5 mm in any dimension;
- openings that do not exceed 1 mm in width regardless of length;
- top openings in which vertical entry is prevented (see figure 4B for examples);
- side openings provided with louvres that are shaped to deflect outwards an external vertically falling object (see figure 4C for examples);
- top or side openings, as shown in figure 4D, that are not located vertically, or within a volume V bounded by a 5° vertical projection up to the size of opening L , above bare conductive parts:
 - at HAZARDOUS VOLTAGE, or
 - which present an energy hazard within the meaning of 2.1.1.5.

NOTE 2 – The examples of figures 4B, 4C, 4D and 4E are not intended to be used as engineering drawings but are only shown to illustrate the intent of these requirements.

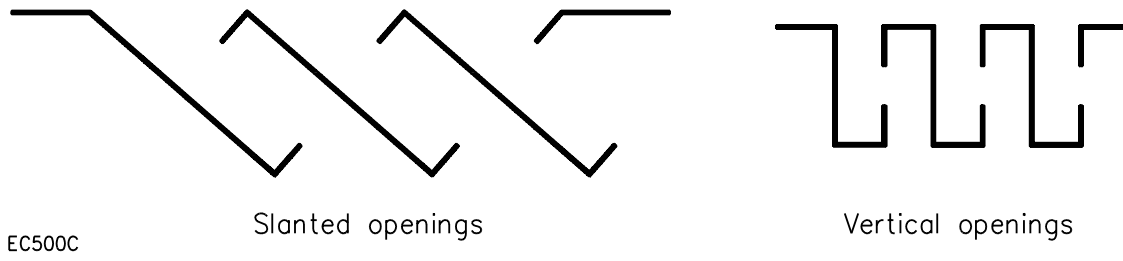
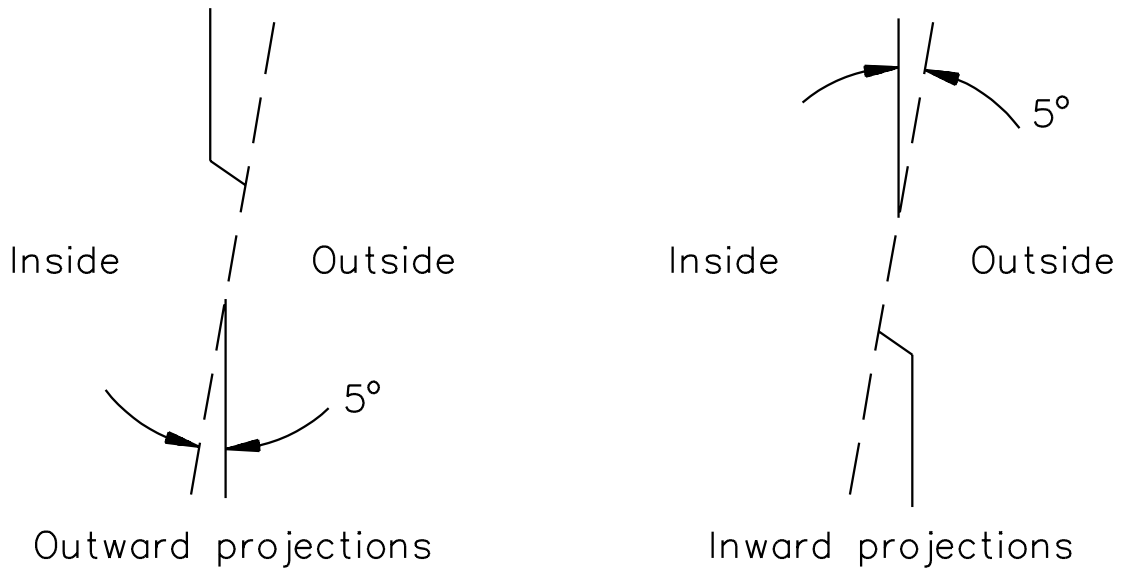
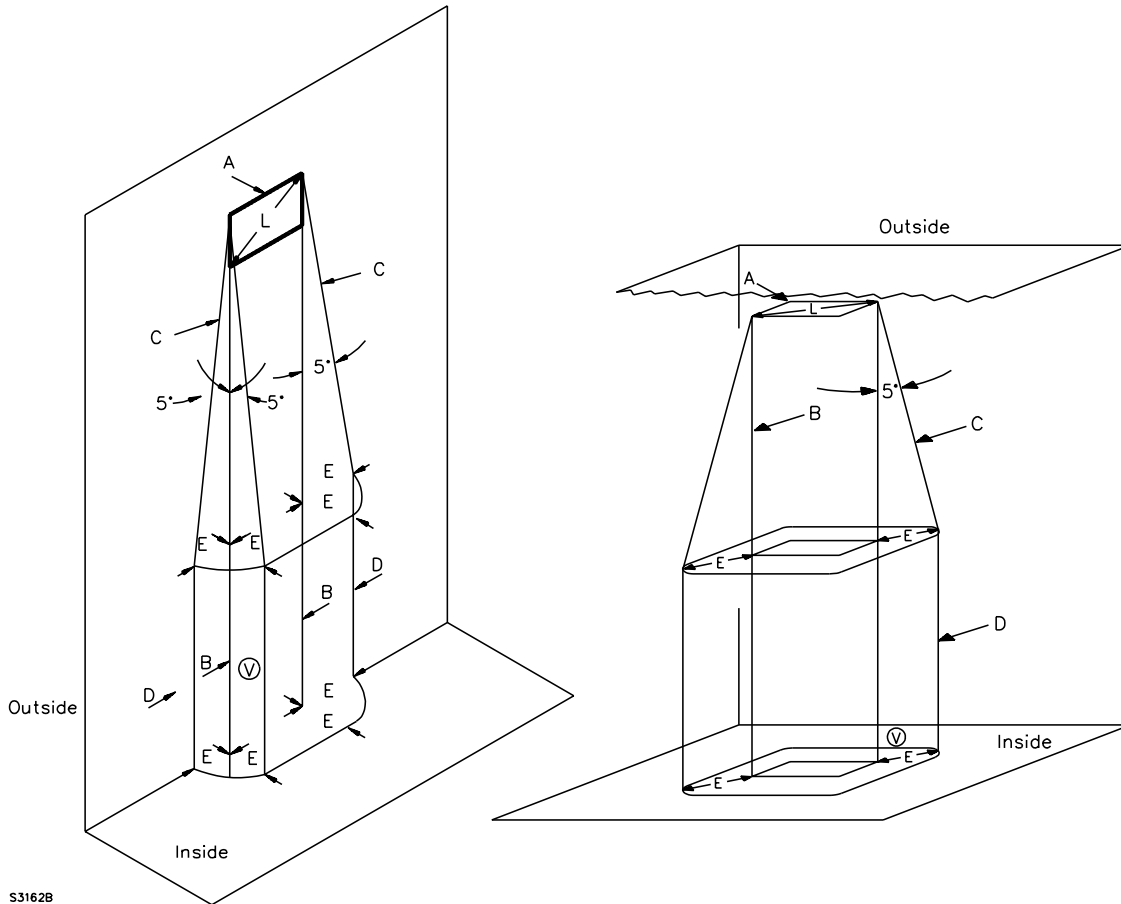

Figure 4B – Examples of cross-sections of designs of openings preventing vertical access



EC513A

Figure 4C – Examples of louvre design



S3162B

- A ENCLOSURE opening.
- B Vertical projection of the outer edges of the opening.
- C Inclined lines that project at a 5° angle from the edges of the opening to points located E distance from B.
- D Line which is projected straight downward in the same plane as the ENCLOSURE side wall.
- E Projection of the opening (not to be greater than L).
- L Maximum dimension of the ENCLOSURE opening.
- V Volume in which bare parts at HAZARDOUS VOLTAGE, or which are energy hazards (see 4.6.1), are not located.

Figure 4D – Enclosure openings

4.6.2 Bottoms of fire enclosures

The bottom of a FIRE ENCLOSURE, or individual barriers, shall provide protection under all internal parts, including partially enclosed components or assemblies, which, under fault conditions, could emit material likely to ignite the supporting surface.

NOTE – See 4.7.2.2 for parts that do not require a FIRE ENCLOSURE.

The bottom or barrier shall be located as, and no smaller in area than, indicated in figure 4E and be horizontal, lipped or otherwise shaped to provide equivalent protection.

An opening in the bottom shall be protected by a baffle, screen or other means so that molten metal and burning material are unlikely to fall outside the FIRE ENCLOSURE.

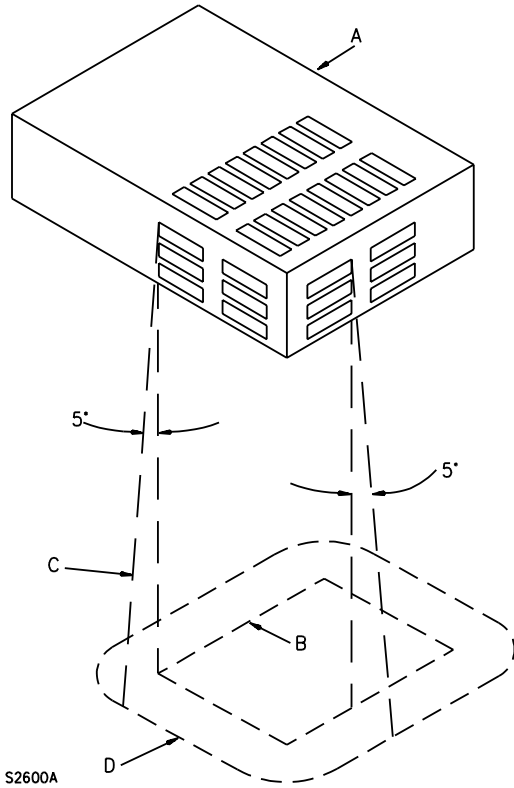

S2600A

- A The portion of a component under which a FIRE ENCLOSURE is required, for example, under those openings in a component or assembly through which flaming particles might be emitted. If the component or assembly does not have its own FIRE ENCLOSURE, the area to be protected is the entire area occupied by the component or assembly.
- B The outline of the area A projected vertically downward onto the horizontal plane of the lowest point of the FIRE ENCLOSURE.
- C Inclined line that traces an outline D on the same plane as B. Moving around the perimeter of the outline B, this line projects at a 5° angle from the vertical at every point round the perimeter of the openings in A and is oriented to trace out the largest area.
- D Minimum outline of the bottom of the FIRE ENCLOSURE. A portion of the side of a FIRE ENCLOSURE which is within the area traced out by the 5° angle is also considered to be part of the bottom of the FIRE ENCLOSURE.

Figure 4E – Typical bottom of a fire enclosure for partially enclosed component or assembly

The requirements of 4.6.2 do not apply to:

- TRANSPORTABLE EQUIPMENT, which is covered by 4.6.4; or
- STATIONARY EQUIPMENT intended only for use in a RESTRICTED ACCESS LOCATION and to be mounted on a concrete floor or other non-combustible surface. Such equipment shall be marked as follows:

SUITABLE FOR MOUNTING ON CONCRETE

OR OTHER NON-COMBUSTIBLE SURFACE ONLY

Compliance is checked by inspection and, where necessary, by the test of clause A.5.

The following constructions are considered to satisfy the requirement without test:

- *no opening in the bottom of a FIRE ENCLOSURE*
- *openings in the bottom of any size under an internal barrier, screen or the like, which itself complies with the requirements for a FIRE ENCLOSURE (see also 4.2.1);*
- *openings in the bottom, each not larger than 40 mm², under components and parts meeting the requirements for FLAMMABILITY CLASS V-1, OR FLAMMABILITY CLASS HF-1;*
- *baffle plate construction as illustrated in figure 4F;*
- *metal bottoms of FIRE ENCLOSURES conforming to the dimensional limits of any line in table 4B;*
- *metal bottom screens having a mesh with nominal openings not greater than 2 mm between centre lines and with wire diameters of not less than 0,45 mm.*

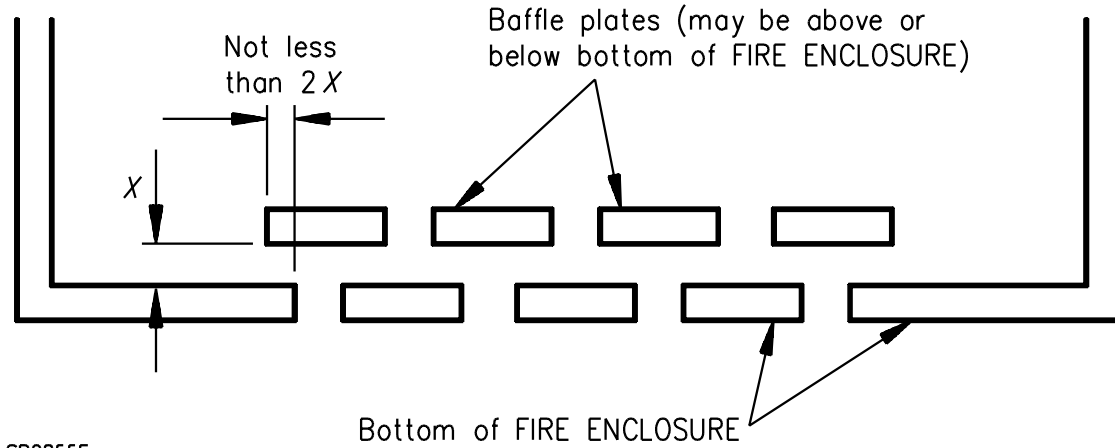

SB0855E

Figure 4F – Baffle plate construction

Table 4B – Size and spacing of openings in metal bottoms of fire enclosures

Applicable to circular holes			Applicable to other shaped openings	
Metal bottom minimum thickness	Maximum diameter of holes	Minimum spacing of holes centre to centre	Maximum area	Minimum spacing of openings border to border
mm	mm	mm	mm ²	mm
0,66	1,1	1,7	1,1	0,55
0,66	1,2	2,3	1,2	1,1
0,76	1,1	1,7	1,1	0,55
0,76	1,2	2,3	1,2	1,1
0,81	1,9	3,1	2,9	1,1
0,89	1,9	3,1	2,9	1,2
0,91	1,6	2,7	2,1	1,1
0,91	2,0	3,1	3,1	1,2
1,0	1,6	2,7	2,1	1,1
1,0	2,0	3,0	3,2	1,0

4.6.3 Doors or covers in fire enclosures

If part of a FIRE ENCLOSURE consists of a door or cover leading to an OPERATOR ACCESS AREA, it shall comply with one of the following requirements a), b) or c):

- a) the door or cover shall be interlocked to comply with the requirements in 2.8; or
- b) a door or cover, intended to be routinely opened by the OPERATOR, shall comply with both of the following conditions:
 - it shall not be removable from other parts of the FIRE ENCLOSURE by the OPERATOR; and
 - it shall be provided with a means to keep it closed during normal operation; or
- c) a door or cover intended only for occasional use by the OPERATOR, such as for the installation of accessories, is permitted to be removable provided that the equipment instructions include directions for correct removal and reinstallation of the door or cover.

Compliance is checked by inspection.

4.6.4 Openings in transportable equipment

The risk of ignition caused by small metallic objects, such as paper clips or staples, moving around inside TRANSPORTABLE EQUIPMENT during transportation shall be reduced by measures to minimize the likelihood of such objects entering the equipment and bridging bare conductive parts between which the power is not limited in accordance with 2.5.

Acceptable measures include:

- providing openings that do not exceed 1 mm in width regardless of length; or
- providing a screen having a mesh with nominal openings not greater than 2 mm between centre lines and constructed with a thread or wire diameter of not less than 0,45 mm; or
- providing internal barriers.

Additionally, where metallized parts of a plastic barrier or ENCLOSURE are within 13 mm of parts of circuits where the available power is greater than 15 VA, one of the following requirements applies:

- access by a foreign metallic object shall be limited in accordance with the above acceptable measures even though the available power meets the limits of 2.5; or
- there shall be a barrier between the bare conductive parts and the ENCLOSURE; or
- fault testing shall be carried out to simulate bridging along a direct path between a bare conductive part and the nearest metallized part of a barrier or ENCLOSURE that is within 13 mm of the bare conductive part.

NOTE – Examples of metallized plastic barriers or ENCLOSURES include those made of conductive composite materials or that are electroplated, vacuum-deposited, painted or foil lined.

Compliance is checked by inspection and measurement and, where appropriate, by test. All doors or covers are closed or in place and peripheral devices or assemblies, such as disk drives, batteries, etc., are installed as intended during the inspection (see also 1.3.6).

If simulated fault testing is carried out, no ignition of the metalized barrier or ENCLOSURE shall occur.

4.6.5 Adhesives for constructional purposes

P

If a barrier or screen provided to comply with 4.6.1, 4.6.2 or 4.6.4 is secured with adhesive to the inside of the ENCLOSURE or to other parts inside the ENCLOSURE, the adhesive shall have adequate bonding properties throughout the life of the equipment.

Compliance is checked by examination of the construction and of the available data. If such data is not available, compliance is checked by the following tests.

A sample of the equipment or a part of the ENCLOSURE with the barrier or screen attached is evaluated with the sample placed with the barrier or screen on the underside.

Condition the sample in an oven at one of the following temperatures for the time durations specified:

100 °C ± 2 °C for one week; or

90 °C ± 2 °C for three weeks; or

82 °C ± 2 °C for eight weeks.

Upon completion of the temperature conditioning:

Remove the sample from oven and leave it at any convenient temperature between 20 °C and 30 °C for 1 h.

Place the sample in a freezer at -40 °C ± 2 °C for 4 h.

Remove and allow the sample to come to any convenient temperature between 20 °C and 30 °C for 8 h.

Place the sample in a cabinet at 91 % to 95 % relative humidity for 72 h.

Remove the sample and leave it at any convenient temperature between 20 °C and 30 °C for 1 h.

Place the sample in an oven at the temperature used for the temperature conditioning for 4 h.

Remove the sample and allow it to reach any convenient temperature between 20 °C and 30 °C for 8 h.

The sample is then immediately subjected to the tests of 4.2 as applicable. The barrier or screen shall not fall off or partly dislodge as a result of these tests.

With the concurrence of the manufacturer, it is permitted to increase any of the above time durations.

4.7 Resistance to fire

P

This subclause specifies requirements intended to reduce the risk of ignition and the spread of flame, both within the equipment and to the outside, by the appropriate use of materials and components and by suitable construction.

NOTE 1 – The risk of ignition is reduced by limiting the maximum temperature of components under normal operating conditions and after a single fault (see 1.4.14), or by limiting the power available in a circuit.

NOTE 2 – The spread of flame in the event of ignition is reduced by the use of flame retardant materials and insulation, or by providing adequate separation.

NOTE 3 – For a ranking of materials with respect to flammability, refer to the notes of 1.2.12.1.

Metals, ceramic materials and glass shall be considered to comply without test.

4.7.1 Reducing the risk of ignition and spread of flame

NAE

For equipment or a portion of equipment, there are two methods of providing protection against ignition and spread of flame that could affect materials, wiring, wound components and electronic components such as integrated circuits, transistors, thyristors, diodes, resistors and capacitors.

Either of the following methods may be used:

Method 1 – Selection and application of components, wiring and materials which reduce the possibility of ignition and spread of flame and, where necessary, by the use of a FIRE ENCLOSURE. The appropriate requirements are detailed in 4.7.2 and 4.7.3. The requirements of 5.3.6 also apply, except for 5.3.6 c), when using this method;

NOTE 1 – Method 1 may be preferred for equipment with a large number of components.

Method 2 – Application of all of the simulated fault tests in 5.3.6. Where this method is used exclusively, a FIRE ENCLOSURE is not required. In particular, 5.3.6 c) applies, which includes testing all relevant components in both PRIMARY CIRCUITS and SECONDARY CIRCUITS.

NOTE 2 – Method 2 may be preferred for equipment with a small number of electronic components.

4.7.2 Conditions for a fire enclosure

A FIRE ENCLOSURE is required when temperatures of parts under fault conditions could be sufficient for ignition.

4.7.2.1 Parts requiring a fire enclosure

Except where Method 2 of 4.7.1 is used exclusively, or as permitted in 4.7.2.2, the following parts are considered to have a risk of ignition and, therefore, require a FIRE ENCLOSURE:

- components in PRIMARY CIRCUITS;
- components in SECONDARY CIRCUITS supplied by power sources which exceed the limits specified in 2.5;
- components in SECONDARY CIRCUITS supplied by limited power sources as specified in 2.5, but not mounted on material of FLAMMABILITY CLASS V-1;
- components within a power supply unit or assembly having a limited power output as specified in 2.5, including overcurrent protective devices, limiting impedances, regulating networks and wiring, up to the point where the limited power source output criteria are met;
- components having unenclosed arcing parts, such as open switch and relay contacts and commutators, in a circuit at HAZARDOUS VOLTAGE or at a HAZARDOUS ENERGY LEVEL; and
- insulated wiring.

4.7.2.2 Parts not requiring a fire enclosure

The following parts do not require a FIRE ENCLOSURE:

- wiring and cables insulated with PVC, TFE, PTFE, FEP, neoprene or polyimide;
- components, including connectors, meeting the requirements of 4.7.3.2, which fill an opening in a FIRE ENCLOSURE;
- connectors in SECONDARY CIRCUITS supplied by power sources which are limited to a maximum of 15 VA (see 1.4.11) under normal operating conditions and after a single fault in the equipment (see 1.4.14);
- connectors in SECONDARY CIRCUITS supplied by limited power sources complying with 2.5;
- other components in SECONDARY CIRCUITS supplied by limited power sources complying with 2.5 and mounted on materials of FLAMMABILITY CLASS V-1;
- plugs and connectors forming part of a power supply cord or INTERCONNECTING CABLE;
- motors;

– other components in SECONDARY CIRCUITS supplied by internal or external power sources which are limited to a maximum of 15 VA (see 1.4.11) under normal operating conditions and after a single fault in the equipment (see 1.4.14) and mounted on material of FLAMMABILITY CLASS HB.

NOTE – In Canada and the United States, additional requirements for protection from overvoltage apply for TNV CIRCUITS.

Compliance with 4.7.2.1 and 4.7.2.2 is checked by inspection and by evaluation of the data provided by the manufacturer. For determining the risk of ignition in cases not specified in 4.7.2, compliance is checked by Method 2 in 4.7.1.

4.7.3 Materials

P

4.7.3.1 General

NAA

ENCLOSURES, components and other parts shall be so constructed, or shall make use of such materials, that the propagation of fire is limited.

NAE

Where material of FLAMMABILITY CLASS HB, OR FLAMMABILITY CLASS HBF, is required, material passing the glow-wire test at 550 °C according to IEC 60695-2-1/1 is acceptable as an alternative.

Where it is not practical to protect components against overheating under fault conditions, the components shall be mounted on materials of FLAMMABILITY CLASS V-1. Additionally, such components shall be separated from material of a class lower than FLAMMABILITY CLASS V-1 (see 1.2.12.1, note 2) by at least 13 mm of air, or by a solid barrier of material of FLAMMABILITY CLASS V-1.

NOTE 1 – See also 4.7.3.5.

NOTE 2 – In Canada and the United States, requirements in addition to 4.7.3.2 and 4.7.3.3 apply to ENCLOSURES and DECORATIVE PARTS having an external surface with an exposed area of greater than 0,9 m² or a single dimension greater than 1,8 m.

NOTE 3 – In considering how to limit propagation of fire, and what are “small parts”, account should be taken of the cumulative effect of small parts when they are adjacent to each other, and also of the possible effect of propagating fire from one part to another.

NOTE 4 – The material flammability requirements in 4.7.3 are summarized in table 4C.

Compliance is checked by inspection and by evaluation of relevant data provided by the manufacturer.

4.7.3.2 Materials for fire enclosures

P

The following requirements apply as appropriate.

The 18 kg mass criterion applies to individual complete equipments, even if they are used in close proximity to each other (e.g. one on top of another). However, if a part of the FIRE ENCLOSURE is removed in such a situation (in the same example, the bottom cover of the top equipment), the combined mass of the equipment applies. In determining the total mass of equipment, supplies, consumable materials, media and recording materials used with the equipment shall not be taken into account.

For MOVABLE EQUIPMENT having a total mass not exceeding 18 kg, the material of a FIRE ENCLOSURE, in the thinnest significant wall thickness used, shall be of FLAMMABILITY CLASS V-1 or shall pass the test of clause A.2.

For MOVABLE EQUIPMENT having a total mass exceeding 18 kg and for all STATIONARY EQUIPMENT, the material of a FIRE ENCLOSURE, in the thinnest significant wall thickness used, shall be of FLAMMABILITY CLASS 5V or shall pass the test of clause A.1.

The material of a FIRE ENCLOSURE that is located less than 13 mm through air from arcing parts such as unenclosed commutators and unenclosed switch contacts, shall pass the test of clause A.3. This requirement applies to ENCLOSURES of equipment and not to covers of components.

The material of a FIRE ENCLOSURE that is located less than 13 mm through air from parts which, under any condition of normal or abnormal operation, could attain a temperature sufficient to ignite the material, shall pass the test of clause A.4.

Materials for components which fill an opening in a FIRE ENCLOSURE, and which are intended to be mounted in this opening shall:

- be of FLAMMABILITY CLASS V-1; OR
- pass the tests of clause A.2; or
- comply with the flammability requirements of the relevant IEC component standard.

NOTE – Examples of these components are fuseholders, switches, pilot lights, connectors and appliance inlets.

Compliance is checked by inspection of the equipment and material data sheets and, if necessary, by the appropriate test or tests in annex A.

4.7.3.3 Materials for components and other parts outside fire enclosures

Except as otherwise noted below, materials for components and other parts (including MECHANICAL ENCLOSURES, ELECTRICAL ENCLOSURES and DECORATIVE PARTS), located outside FIRE ENCLOSURES, shall be of FLAMMABILITY CLASS HB, OR FLAMMABILITY CLASS HBF.

NOTE – Where a MECHANICAL OR AN ELECTRICAL ENCLOSURE also serves as a FIRE ENCLOSURE, the requirements for FIRE ENCLOSURES apply.

Requirements for materials in air filters assemblies are in 4.7.3.5 and for materials in high-voltage components in 4.7.3.6.

Connectors shall comply with one of the following:

- be made of material of FLAMMABILITY CLASS V-2; OR
- pass the tests of clause A.2; or
- comply with the flammability requirements of the relevant IEC component standard; or
- be mounted on material of FLAMMABILITY CLASS V-1 and be of a small size; or
- be located in a SECONDARY CIRCUIT supplied by a power source that is limited to a maximum of 15 VA (see 1.4.11) under normal operating conditions and after a single fault in the equipment (see 1.4.14).

The requirement for materials for components and other parts to be of FLAMMABILITY CLASS HB, OR FLAMMABILITY CLASS HBF, does not apply to any of the following:

- electrical components which do not present a fire hazard under abnormal operating conditions when tested according to 5.3.6;
- materials and components within an ENCLOSURE of 0,06 m³ or less, consisting totally of metal and having no ventilation openings, or within a sealed unit containing an inert gas;
- meter cases (if otherwise determined to be suitable for mounting of parts at HAZARDOUS VOLTAGE), meter faces and indicator lamps or jewels;
- components meeting the flammability requirements of a relevant IEC component standard which includes such requirements;
- electronic components, such as integrated circuit packages, opto-coupler packages, capacitors and other small parts that are:
 - mounted on material of FLAMMABILITY CLASS V-1; OR
 - supplied from a power source of no more than 15 VA (see 1.4.11) under normal operating conditions or after a single fault in the equipment (see 1.4.14) and mounted on material of FLAMMABILITY CLASS HB;
- wiring, cables and connectors insulated with PVC, TFE, PTFE, FEP, neoprene or polyimide;

- individual clamps (not including helical wraps or other continuous forms), lacing tape, twine and cable ties used with wiring harnesses;
- gears, cams, belts, bearings and other small parts which would contribute negligible fuel to a fire, including DECORATIVE PARTS, labels, mounting feet, key caps, knobs and the like;
- supplies, consumable materials, media and recording materials;
- parts which are required to have particular properties in order to perform intended functions, such as rubber rollers for paper pick-up and delivery, and ink tubes.

Compliance is checked by inspection of the equipment and material data sheets and, if necessary, by the appropriate test or tests in annex A.

4.7.3.4 Materials for components and other parts inside fire enclosures

NAA

Requirements for materials in air filters assemblies are in 4.7.3.5 and requirements for materials in high-voltage components in 4.7.3.6.

NAE

Inside FIRE ENCLOSURES, materials for components and other parts, (including MECHANICAL and ELECTRICAL ENCLOSURES located inside FIRE ENCLOSURES), shall comply with one of the following:

- be of FLAMMABILITY CLASS V-2, OR FLAMMABILITY CLASS HF-2; OR
- pass the flammability test described in clause A.2; or
- meet the flammability requirements of a relevant IEC component standard which includes such requirements.

The above requirement does not apply to any of the following:

- electrical components which do not present a fire hazard under abnormal operating conditions when tested according to 5.3.6;
- materials and components within an ENCLOSURE of 0,06 m³ or less, consisting totally of metal and having no ventilation openings, or within a sealed unit containing an inert gas;
- one or more layers of thin insulating material, such as adhesive tape, used directly on any surface within a FIRE ENCLOSURE, including the surface of current-carrying parts, provided that the combination of the thin insulating material and the surface of application complies with the requirements of FLAMMABILITY CLASS V-2, OR FLAMMABILITY CLASS HF-2;

NOTE – Where the thin insulating material referred to in the above exclusion is on the inner surface of the FIRE ENCLOSURE itself, the requirements in 4.6.2 continue to apply to the FIRE ENCLOSURE.

- meter cases (if otherwise determined to be suitable for mounting of parts at HAZARDOUS VOLTAGE), meter faces and indicator lamps or jewels;
- electronic components, such as integrated circuit packages, opto-coupler packages, capacitors and other small parts that are mounted on material of FLAMMABILITY CLASS V-1;

- wiring, cables and connectors insulated with PVC, TFE, PTFE, FEP, neoprene or polyimide;
- individual clamps (not including helical wraps or other continuous forms), lacing tape, twine and cable ties used with wiring harnesses;
- wire which complies with the requirements for "VW-1" or "FT-1" or better, and which is so marked is considered to comply with this requirement. DC
DC
- the following parts, provided that they are separated from electrical parts (other than insulated wires and cables) which under fault conditions are likely to produce a temperature that could cause ignition, by at least 13 mm of air or by a solid barrier of material of FLAMMABILITY CLASS V-1:
 - gears, cams, belts, bearings and other small parts which would contribute negligible fuel to a fire, including, labels, mounting feet, key caps, knobs and the like;
 - supplies, consumable materials, media and recording materials;
 - parts which are required to have particular properties in order to perform intended functions, such as rubber rollers for paper pick-up and delivery, and ink tubes;
 - tubing for air or any fluid systems, containers for powders or liquids and foamed plastic parts, provided that they are of FLAMMABILITY CLASS HB, or FLAMMABILITY CLASS HBF.

Compliance is checked by inspection of the equipment and material data sheets and, if necessary, by the appropriate test or tests of annex A.

4.7.3.5 Materials for air filter assemblies

Air filter assemblies shall be constructed of materials of FLAMMABILITY CLASS V-2, OR FLAMMABILITY CLASS HF-2.

This requirement does not apply to the following constructions:

- air filter assemblies in air circulating systems, whether or not airtight, that are not intended to be vented outside the FIRE ENCLOSURE;
- air filter assemblies located inside or outside a FIRE ENCLOSURE, provided that the filter materials are separated by a metal screen from parts that could cause ignition. This screen may be perforated and shall meet the requirements of 4.6.2 for the bottoms of FIRE ENCLOSURES;
- air filter frames constructed of materials of FLAMMABILITY CLASS HB, provided that they are separated from electrical parts (other than insulated wires and cables) which under fault conditions are likely to produce a temperature that could cause ignition, by at least 13 mm of air or by a solid barrier of material of FLAMMABILITY CLASS V-1;
- air filter assemblies located externally to the FIRE ENCLOSURE, constructed of materials of FLAMMABILITY CLASS HB, OR FLAMMABILITY CLASS HBF.

Compliance is checked by inspection of the equipment and material data sheets and, if necessary, by the appropriate test or tests of annex A.

4.7.3.6 Materials used in high-voltage components

P

High-voltage components operating at peak-to-peak voltages exceeding 4 kV shall either be of FLAMMABILITY CLASS V-2, OF FLAMMABILITY CLASS HF-2, OR comply with 14.4 of IEC 60065.

Compliance is checked by the inspection of the equipment and material data sheets and, if necessary by the appropriate test or tests of annex A, or by the tests described in 14.4 of IEC 60065.

Table 4C – Summary of material flammability requirements

Part	Requirement
FIRE ENCLOSURES 4.7.3.2	MOVABLE EQUIPMENT > 18 kg and STATIONARY EQUIPMENT
	– 5V – test A.1
	If < 13 mm of air from unenclosed arcing parts: HAI (test A.3)
	If < 13 mm of air from parts at high temperatures: HWI (test A.4)
	MOVABLE EQUIPMENT ≤ 18 kg
	– V-1 – test A.2
	If < 13 mm of air from unenclosed arcing parts: HAI (test A.3)
	If < 13 mm of air from parts at high temperatures: HWI (test A.4)
	Parts which fill an opening
	– V-1 – test A.2 – component standard
Components and parts, including MECHANICAL and ELECTRICAL ENCLOSURES, outside FIRE ENCLOSURES 4.7.3.1 and 4.7.3.3	– HB – HBF – GWT 550 °C – IEC 60695-2-1/1 For connectors and exceptions see 4.7.3.3
Components and parts, including MECHANICAL and ELECTRICAL ENCLOSURES, inside FIRE ENCLOSURES 4.7.3.4	– V-2 – HF-2 – test A.2 – component standard For exceptions see 4.7.3.4
Air filter assemblies 4.7.3.5	– V-2 – HF-2 For exceptions see 4.7.3.5
High voltage (>4 kV) components	– V-2 – HF-2 – test of IEC 60065, 14.4
HAI: High Amp Ignition (also called High Current Arc Ignition). HWI: Hot Wire Ignition. GWT: Glow-Wire Test.	

5 Electrical requirements and simulated abnormal conditions

D

5.1 Touch current and protective conductor current

In this subclause measurements of current through networks simulating the impedance of the human body are referred to as measurements of TOUCH CURRENT.

5.1.1 General

Equipment shall be so designed and constructed that neither TOUCH CURRENT nor PROTECTIVE CONDUCTOR CURRENT is likely to create an electric shock hazard.

Compliance is checked by testing in accordance with 5.1.2 to 5.1.7 inclusive, and, if relevant, 5.1.8 (see also 1.4.4).

However, if it is clear from a study of the circuit diagrams of either PERMANENTLY CONNECTED EQUIPMENT OR PLUGGABLE EQUIPMENT TYPE B, that has a PROTECTIVE EARTHING CONDUCTOR, that the TOUCH CURRENT will exceed 3,5 mA r.m.s., but that the PROTECTIVE CONDUCTOR CURRENT will not exceed 5 % of input current, the tests of 5.1.5, 5.1.6 and 5.1.7 are not made.

5.1.2 Equipment under test (EUT)

Systems of interconnected equipment with individual connections to the AC MAINS SUPPLY shall have each piece of equipment tested separately. Systems of interconnected equipment with one common connection to the AC MAINS SUPPLY shall be treated as a single piece of equipment. See also 1.4.10 regarding the inclusion of optional features.

NOTE – Systems of interconnected equipment are specified in more detail in IEC 60990, annex A.

Equipment which is designed for connection to multiple power sources, only one of which is required at a time (e.g. for backup) shall be tested with only one source connected.

Equipment requiring power simultaneously from two or more power sources shall be tested with all power sources connected.

5.1.3 Test circuit

Equipment is tested using the test circuit in figure 5A (for single-phase equipment to be connected only to a star TN or TT power distribution system) or figure 5B (for three-phase equipment to be connected only to a star TN or TT power distribution system) or where appropriate, another test circuit from IEC 60990, figures 7, 9, 10, 12, 13 or 14.

The use of a test transformer for isolation is optional. For maximum safety, a test transformer for isolation (T in figures 5A and 5B) is used and the main protective earthing terminal of the EUT is earthed. Any capacitive leakage in the transformer must then be taken into account. As an alternative to earthing the EUT, the test transformer secondary and the EUT are left floating (not earthed) in which case capacitive leakage in the transformer need not be taken into account.

If transformer T is not used, the equipment is mounted on an insulating stand, and appropriate safety precautions are taken in view of the possibility of the BODY of the equipment being at a HAZARDOUS VOLTAGE.

Equipment to be connected to an IT power distribution system is tested accordingly (see figures 9, 10 and 12 of IEC 60990). Such equipment may also be connected to a TN or TT power distribution system.

Single-phase equipment intended to be operated between two line conductors is tested using a three-phase test circuit such as figure 5B.

If it is inconvenient to test equipment at the most unfavourable supply voltage (see 1.4.5), it is permitted to test the equipment at any available voltage within the tolerance of RATED VOLTAGE or within the RATED VOLTAGE RANGE, and then calculate the results.

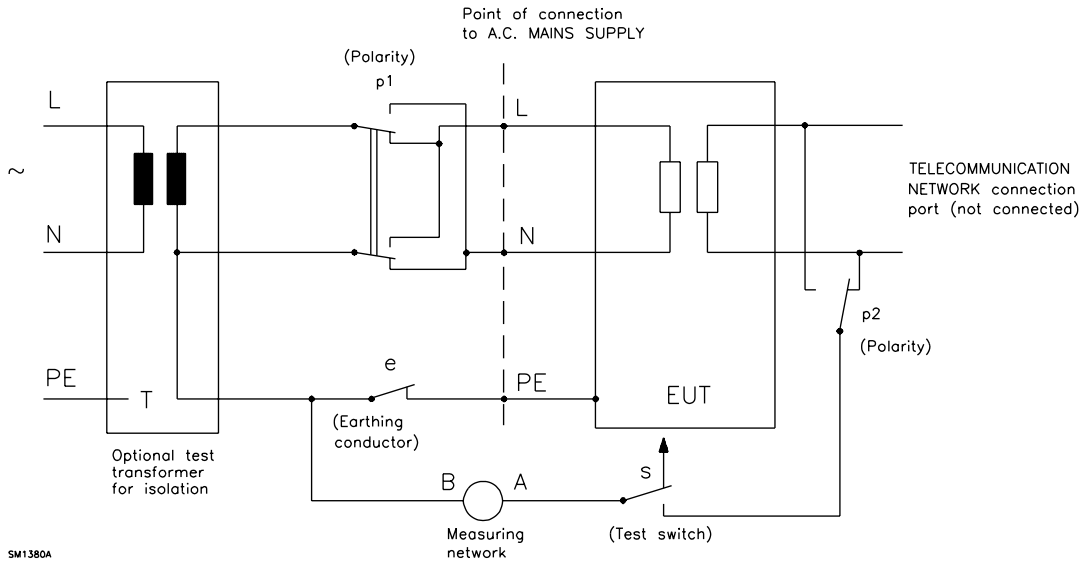

NOTE – This figure is derived from IEC 60990, figure 6.

Figure 5A – Test circuit for touch current of single-phase equipment on a star TN or TT power supply system

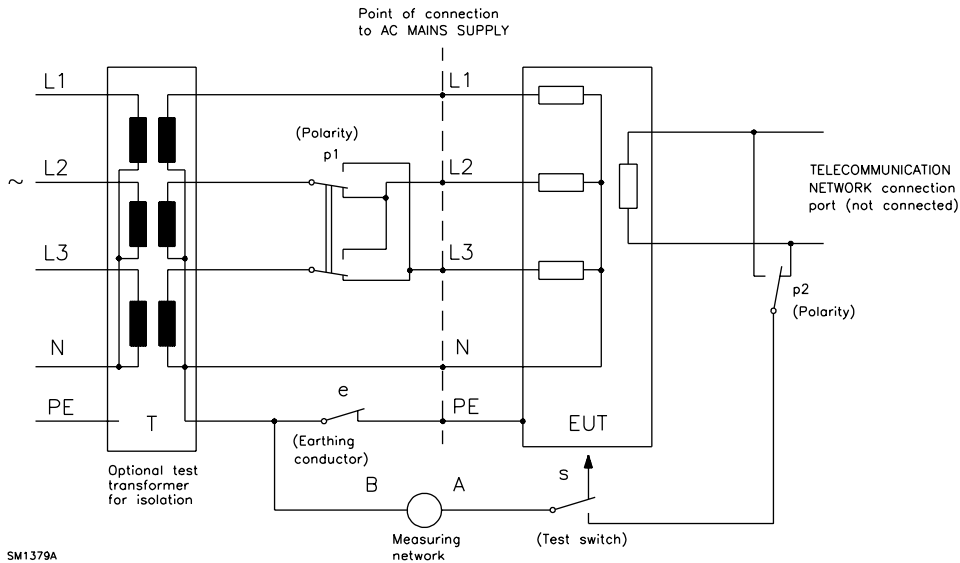

NOTE – This figure is derived from IEC 60990, figure 11.

Figure 5B – Test circuit for touch current of three-phase equipment on a star TN or TT power supply system

5.1.4 Application of measuring instrument

Tests are conducted using one of the measuring instruments in annex D, or any other circuit giving the same results.

Terminal B of the measuring instrument is connected to the earthed (neutral) conductor of the supply (see figure 5A or 5B).

Terminal A of the measuring instrument is connected as specified in 5.1.5.

For an accessible non-conductive part, the test is made to metal foil having dimensions of 10 cm x 20 cm in contact with the part. If the area of the foil is smaller than the surface under test, the foil is moved so as to test all parts of the surface. Where adhesive metal foil is used, the adhesive shall be conductive. Precautions are taken to prevent the metal foil from affecting the heat dissipation of the equipment.

NOTE 1 – The foil test simulates hand contact.

Accessible conductive parts that are incidentally connected to other parts are tested both as connected and disconnected parts.

NOTE 2 – Incidentally connected parts are described in more detail in IEC 60990, annex C.

5.1.5 Test procedure

For equipment having a protective earthing connection or a FUNCTIONAL EARTHING connection, terminal A of the measuring instrument is connected via measurement switch "s" to the equipment earthing terminal of the EUT, with the earthing conductor switch "e" open.

The test is also carried out, on all equipment, with terminal A of the measuring network connected via measurement switch "s" to each unearthed or non-conductive accessible part and each unearthed accessible circuit, in turn, with the earthing conductor switch "e" closed.

Additionally:

- for single-phase equipment, the tests are repeated in reverse polarity (switch "p1");
- for three-phase equipment, the tests are repeated in reverse polarity (switch "p1") unless the equipment is sensitive to phase sequence.

When testing three-phase equipment, any components used for EMC purposes and connected between line and earth are disconnected one at a time; for this purpose, groups of components in parallel connected through a single connection are treated as single components. Each time a line-to-earth component is disconnected the sequence of switch operations is repeated.

NOTE – Where filters are normally encapsulated, it may be necessary to provide an unencapsulated unit for test or to simulate the filter network.

For each placement of the measuring instrument, any switches in the PRIMARY CIRCUIT and likely to be operated in normal use are open and closed in all possible combinations.

After applying each test condition, the equipment is restored to its original condition, i.e. without fault or consequential damage.

5.1.6 Test measurements

Either the r.m.s. value of the voltage U_2 is measured using the measuring instrument of figure D.1, or the r.m.s. value of the current is measured using the measuring instrument of figure D.2.

The D.1 instrument gives a more accurate measurement than the D.2 instrument if the waveform is non-sinusoidal and the fundamental frequency exceeds 100 Hz.

Alternatively, the peak value of the voltage U_2 is measured using the measuring instrument described in clause D.1.

If the voltage U_2 is measured using the measuring instrument described in clause D.1, the following calculation is used:

$$\text{TOUCH CURRENT (A)} = U_2 / 500$$

NOTE – Although r.m.s. values of TOUCH CURRENT have traditionally been measured, peak values provide better correlation with the response of the human body to non-sinusoidal current waveforms.

None of the values measured in accordance with 5.1.6 shall exceed the relevant limits in table 5A, except as permitted in 5.1.7.

Table 5A – Maximum current

Type of equipment	Terminal A of measuring instrument connected to:	Maximum TOUCH CURRENT mA r.m.s. ¹⁾	Maximum PROTECTIVE CONDUCTOR CURRENT
All equipment	Accessible parts and circuits not connected to protective earth	0,25	–
HAND-HELD	Equipment main protective earthing terminal (if any)	0,75	–
MOVABLE (other than HAND-HELD, but including TRANSPORTABLE EQUIPMENT)		3,5	–
STATIONARY, PLUGGABLE TYPE A		3,5	–
All other STATIONARY EQUIPMENT – not subject to the conditions of 5.1.7 – subject to the conditions of 5.1.7		3,5 –	– 5 % of input current
1) If peak values of TOUCH CURRENT are measured, the maximum values <u>are</u> obtained by multiplying the r.m.s. values by 1,414.			

DE

5.1.7 Equipment with touch current exceeding 3,5 mA

NAA

For STATIONARY PERMANENTLY CONNECTED EQUIPMENT OR STATIONARY PLUGGABLE EQUIPMENT TYPE B having a main protective earthing terminal, if the TOUCH CURRENT measurements exceed 3,5 mA r.m.s., all of the following conditions apply:

- the r.m.s. PROTECTIVE CONDUCTOR CURRENT shall not exceed 5 % of the input current per line under normal operating conditions. If the load is unbalanced, the largest of the three line currents shall be used for this calculation. To measure the PROTECTIVE CONDUCTOR CURRENT, the procedure for measuring TOUCH CURRENT is used but the measuring instrument is replaced by an ammeter of negligible impedance; and
- the cross-sectional area of the PROTECTIVE BONDING CONDUCTOR shall be not be less than that of the conductors in table 3B (see 3.2.5), with a minimum of 1,0 mm² in the path of high PROTECTIVE CONDUCTOR CURRENT; and
- one of the following labels, or a label with similar wording, shall be affixed adjacent to the equipment AC MAINS SUPPLY connection:

WARNING
HIGH LEAKAGE CURRENT EARTH CONNECTION
ESSENTIAL BEFORE CONNECTING SUPPLY

WARNING
HIGH TOUCH CURRENT EARTH CONNECTION
ESSENTIAL BEFORE CONNECTING SUPPLY

NOTE – Attention is drawn to IEC 60364-7-707.

5.1.8 Touch currents to and from telecommunication networks

D

NOTE – In this subclause, references to “TELECOMMUNICATION NETWORK connection ports” (or telecommunication ports) are intended to cover those connection points to which a TELECOMMUNICATION NETWORK is intended to be attached. Such references are not intended to include other data ports, such as those commonly identified as serial, parallel, keyboard, game, joystick, etc.

5.1.8.1 Limitation of the touch current to a telecommunication network

The TOUCH CURRENT from equipment supplied from the AC MAINS SUPPLY to a TELECOMMUNICATION NETWORK shall be limited.

Compliance is checked using the test circuit detailed in 5.1.3.

The tests are not applied to equipment where the circuit to be connected to a TELECOMMUNICATION NETWORK is connected to a protective earthing or FUNCTIONAL EARTHING terminal in the equipment; the current from the EUT to the TELECOMMUNICATION NETWORK is considered to be zero.

For equipment having more than one circuit to be connected to a TELECOMMUNICATION NETWORK, the test is applied to only one example of each type of circuit.

For equipment that has no main protective earthing terminal, the earthing conductor switch “e”, if connected to a FUNCTIONAL EARTHING terminal on the EUT, is left open. Otherwise it is closed.

Terminal B of the measuring instrument is connected to the earthed (neutral) conductor of the supply. Terminal A is connected via the measurement switch “s” and the polarity switch “p2” to the TELECOMMUNICATION NETWORK connection port.

For single-phase equipment, the test is made in all combinations of the polarity switches “p1” and “p2”.

For three-phase equipment, the test is made in both positions of polarity switch “p2”.

After applying each test condition, the equipment is restored to its original operating state.

Test measurements are made using one of the measuring instruments of annex D as described in 5.1.6.

None of the values measured in accordance with 5.1.8.1 shall exceed 0,25 mA r.m.s.

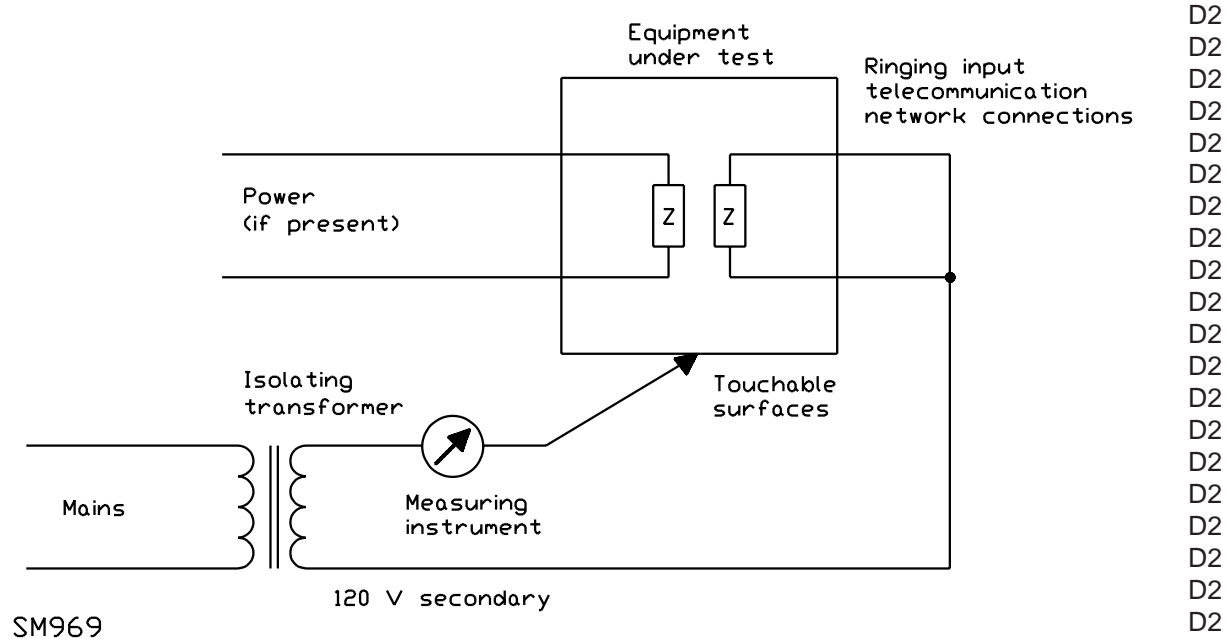

Figure 5D – Test circuit for earth leakage current on other than CLASS I EQUIPMENT

5.1.8.2 Summation of touch currents from telecommunication networks

NAA

NOTE – Annex W explains the background to 5.1.8.2.

An EUT that receives ringing voltages on more than one TELECOMMUNICATION NETWORK connection port shall have simulated ringing applied to the network connections. D2

Simulated ringing is applied to 3 % (rounding down) of the ports receiving ringing in excess of three ports. D2

An EUT that provides TELECOMMUNICATION NETWORK connection ports for connection of multiple items of other telecommunication equipment, shall not create a hazard for USERS and TELECOMMUNICATION NETWORK SERVICE PERSONNEL due to summation of TOUCH CURRENT.

In these requirements, abbreviations have the following meanings:

- I_1 is the TOUCH CURRENT received from other equipment via a TELECOMMUNICATION NETWORK at a telecommunication port of the EUT;
- ΣI_1 is the summation of TOUCH CURRENTS received from other equipment at all such telecommunication ports of the EUT;
- I_2 is the TOUCH CURRENT due to the AC MAINS SUPPLY of the EUT.

It shall be assumed that each telecommunication port receives 0,25 mA (I_1) from the other equipment, unless the actual current from the other equipment is

The following requirements, a) or b) as applicable, shall be met:

a) EUT with earthed telecommunication ports

For an EUT in which each telecommunication port is connected to the main protective earthing terminal of the EUT, the following items 1), 2) and 3) shall be considered:

1) If ΣI_1 (not including I_2) exceeds 3,5 mA:

- the equipment shall have provision for a permanent connection to protective earth in addition to the PROTECTIVE EARTHING CONDUCTOR in the power supply cord of PLUGGABLE EQUIPMENT TYPE A OR B; and
- the installation instructions shall specify the provision of a permanent connection to protective earth with a cross-sectional area of not less than 2,5 mm², if mechanically protected, or otherwise 4,0 mm²; and
- one of the following labels, or a label with similar wording, shall be affixed adjacent to the permanent earth connection:

WARNING
HIGH LEAKAGE CURRENT EARTH CONNECTION
ESSENTIAL BEFORE MAKING
TELECOMMUNICATION NETWORK CONNECTIONS

WARNING
HIGH TOUCH CURRENT EARTH CONNECTION
ESSENTIAL BEFORE MAKING
TELECOMMUNICATION NETWORK CONNECTIONS

It is permitted to combine this label with the label in 5.1.7.

2) ΣI_1 plus I_2 shall comply with the limits in table 5A (see 5.1.6).

3) If relevant, such equipment shall comply with 5.1.7. The value of I_2 shall be used to calculate the 5 % input current limit per phase specified in 5.1.7.

Compliance with item a) is checked by inspection and if necessary by test.

If the equipment has provision for a permanent protective earth connection in accordance with item 1) above, it is not necessary to make any measurements, except that I_2 shall comply with the relevant requirements of 5.1.

TOUCH CURRENT tests, if necessary, are made using the relevant measuring instrument described in annex D or any other instrument giving the same results. A capacitively coupled a.c. source of the same line frequency and phase as the AC MAINS SUPPLY is applied to each telecommunication port such that 0,25 mA, or the actual current from other equipment if known to be lower, is available to flow into that telecommunication port. The current flowing in the earthing conductor is then measured.

b) EUT whose telecommunication ports have no reference to protective earth

If the telecommunication ports on the EUT do not have a common connection, each telecommunication port shall comply with 5.1.8.1

If all telecommunication ports or any groups of such ports have a common connection, the total TOUCH CURRENT from each common connection shall not exceed 3,5 mA.

Compliance with item b) is checked by inspection and if necessary by the tests of 5.1.8.1 or, if there are common connection points, by the following test:

A capacitively coupled a.c. source of the same frequency and phase as the AC MAINS SUPPLY is applied to each telecommunication port such that 0,25 mA, or the actual current from the other equipment if known to be lower, is available to flow into that telecommunication port. Common connection points are tested in accordance with 5.1, whether or not the points are accessible.

5.2 Electric strength

NOTE – Where specific reference to conducting the electric strength test according to 5.2 is made in other parts of this standard, it is intended that the electric strength test be conducted with the equipment in a well-heated condition according to 5.2.1.

Where specific reference to conducting the electric strength test according to 5.2.2 is made in other parts of this standard, it is intended that the electric strength test be conducted without preheating according to 5.2.1.

5.2.1 General

The electric strength of the solid insulation used in the equipment shall be adequate.

Compliance is checked in accordance with 5.2.2 while the equipment is still in a well-heated condition immediately following the heating test as specified in 4.5.1.

If components or subassemblies are tested separately outside the equipment, they are brought to the temperature attained by that part during the heating test (e.g. by placing them in an oven) prior to performing the electric strength test. However, it is permitted to conduct electric strength testing of thin sheet material for SUPPLEMENTARY INSULATION OR REINFORCED INSULATION, referenced in 2.10.5.2, at room temperature.

5.2.2 Test procedure

The insulation is subjected either to a voltage of substantially sine-wave form having a frequency of 50 Hz or 60 Hz, or to a DC VOLTAGE equal to the peak voltage of the prescribed a.c. test voltage. Unless otherwise specified elsewhere in this standard, test voltages are as specified in table 5B for the appropriate grade of INSULATION (FUNCTIONAL, BASIC, SUPPLEMENTARY OR REINFORCED) and the WORKING VOLTAGE (U), determined in 2.10.2, across the insulation. DC values of WORKING VOLTAGE shall be used for DC VOLTAGES and peak values for other voltages.

The voltage applied to the insulation under test is gradually raised from zero to the prescribed voltage and held at that value for 60 s.

NOTE 1 – For ROUTINE TESTS specified elsewhere in this standard, it is permitted to reduce the duration of the electric strength test to 1 s.

There shall be no insulation breakdown during the test.

Insulation breakdown is considered to have occurred when the current which flows as a result of the application of the test voltage rapidly increases in an uncontrolled manner, i.e. the insulation does not restrict the flow of the current. Corona discharge or a single momentary flashover is not regarded as insulation breakdown.

Insulation coatings are tested with metal foil in contact with the insulating surface. This procedure is limited to places where the insulation is likely to be weak, for example where there are sharp metal edges under the insulation. If practicable, insulation linings are tested separately. Care is taken that the metal foil is so placed that no flashover occurs at the edges of the insulation. Where adhesive metal foil is used, the adhesive shall be conductive.

To avoid damage to components or insulation which are not involved in the test, disconnection of integrated circuits or the like in and the use of equipotential bonding are permitted.

For equipment incorporating both REINFORCED INSULATION and lower grades of insulation, care is taken that the voltage applied to the REINFORCED INSULATION does not overstress BASIC INSULATION or SUPPLEMENTARY INSULATION.

NOTE 2 – Where there are capacitors across the insulation under test (e.g. radio-frequency filter capacitors), it is recommended that d.c. test voltages are used.

NOTE 3 – Components providing a d.c. path in parallel with the insulation to be tested, such as discharge resistors for filter capacitors and voltage limiting devices, should be disconnected.

Where insulation of a transformer winding varies along the length of the winding in accordance with 2.10.10, an electric strength test method is used that stresses the insulation accordingly.

NOTE 4 – An example of such a test method is an induced voltage test which is applied at a frequency sufficiently high to avoid saturation of the transformer. The input voltage is raised to a value which would induce an output voltage equal to the required test voltage.

No test is applied to FUNCTIONAL INSULATION, unless 5.3.4 b) has been selected.

**Table 5B – Test voltages for electric strength tests
Part 1**

Grade of Insulation	Points of application (as appropriate)						
	PRIMARY CIRCUIT to BODY					SECONDARY CIRCUIT to BODY	
	PRIMARY CIRCUIT to SECONDARY CIRCUIT Between parts in PRIMARY CIRCUITS					Between independent SECONDARY CIRCUITS	
	Working voltage					Working voltage	
	$U \leq 184 \text{ V}$ peak or d.c. 2)	$184 \text{ V} < U \leq 354 \text{ V}$ peak or d.c. 3)	$354 \text{ V} < U \leq 1.41 \text{ kV}$ peak or d.c.	$1.41 \text{ kV} < U \leq 10 \text{ kV}$ peak or d.c. 4)	$10 \text{ kV} < U \leq 50 \text{ kV}$ peak or d.c.	$U \leq 42.4 \text{ V}$ peak, or 60 V d.c. 5)	42.4 V peak or 60 V d.c. < $U \leq 10 \text{ kV}$ peak or d.c. 5)
Test voltage, volts r.m.s. 1)					Test voltage, voltage r.m.s. 1)		
FUNCTIONAL	1 000	1 500	see V_a in table 5B Part 2	see V_a in table 5B Part 2	$1,06 U$	500	see V_a in table 5B Part 2
BASIC, SUPPLEMENTARY	1 000	1 500	see V_a in table 5B Part 2	see V_a in table 5B Part 2	$1,06 U$	No Test	see V_a in table 5B Part 2
REINFORCED	2 000	3 000	3 000	see V_b in table 5B Part 2	$1,06 U$	No Test	see V_b in table 5B Part 2

Table 5B – Test voltages for electric strength tests Continued

Grade of Insulation	Points of application (as appropriate)						
	PRIMARY CIRCUIT to BODY					SECONDARY CIRCUIT to BODY	
	PRIMARY CIRCUIT to SECONDARY CIRCUIT Between parts in PRIMARY CIRCUITS					Between independent SECONDARY CIRCUITS	
	Working voltage					Working voltage	
	$U \leq 184 \text{ V}$ peak or d.c. 2)	$184 \text{ V} < U \leq 354 \text{ V}$ peak or d.c. 3)	$354 \text{ V} < U \leq 1.41 \text{ kV}$ peak or d.c.	$1.41 \text{ kV} < U \leq 10 \text{ kV}$ peak or d.c. 4)	$10 \text{ kV} < U \leq 50 \text{ kV}$ peak or d.c.	$U \leq 42.4 \text{ V}$ peak, or 60 V d.c. 5)	42.4 V peak or 60 V d.c. < $U \leq 10 \text{ kV}$ peak or d.c. 5)
Test voltage, volts r.m.s. 1)					Test voltage, voltage r.m.s. 1)		
<p>1) For WORKING VOLTAGES exceeding 10 kV peak or d.c. in SECONDARY CIRCUITS, the same test voltages as for PRIMARY CIRCUITS apply.</p> <p>2) Use this column for d.c. mains supplies up to and including 130 V and subject to MAINS TRANSIENT VOLTAGES.</p> <p>3) Use this column for d.c. mains supplies over 130 V, up to and including 250 V and subject to MAINS TRANSIENT VOLTAGES.</p> <p>4) Use this column for d.c. mains supplies over 250 V and subject to MAINS TRANSIENT VOLTAGES.</p> <p>5) Use these columns for d.c. derived within the equipment from a.c. supplies, or to d.c. derived from equipment within the same building.</p>							

Table 5B – Test voltages for electric strength tests
Part 2

U peak or d.c.	V _a r.m.s.	V _b r.m.s.	U peak or d.c.	V _a r.m.s.	V _b r.m.s.	U peak or d.c.	V _a r.m.s.	V _b r.m.s.
34	500	800	250	1 261	2 018	1 750	3 257	3 257
35	507	811	260	1 285	2 055	1 800	3 320	3 320
36	513	821	270	1 307	2 092	1 900	3 444	3 444
38	526	842	280	1 330	2 127	2 000	3 566	3 566
40	539	863	290	1 351	2 162	2 100	3 685	3 685
42	551	882	300	1 373	2 196	2 200	3 803	3 803
44	564	902	310	1 394	2 230	2 300	3 920	3 920
46	575	920	320	1 414	2 263	2 400	4 034	4 034
48	587	939	330	1 435	2 296	2 500	4 147	4 147
50	598	957	340	1 455	2 328	2 600	4 259	4 259
52	609	974	350	1 474	2 359	2 700	4 369	4 369
54	620	991	360	1 494	2 390	2 800	4 478	4 478
56	630	1 008	380	1 532	2 451	2 900	4 586	4 586
58	641	1 025	400	1 569	2 510	3 000	4 693	4 693
60	651	1 041	420	1 605	2 567	3 100	4 798	4 798
62	661	1 057	440	1 640	2 623	3 200	4 902	4 902
64	670	1 073	460	1 674	2 678	3 300	5 006	5 006
66	680	1 088	480	1 707	2 731	3 400	5 108	5 108
68	690	1 103	500	1 740	2 784	3 500	5 209	5 209
70	699	1 118	520	1 772	2 835	3 600	5 309	5 309

Table 5B – Test voltages for electric strength tests Continued on Next Page

Table 5B – Test voltages for electric strength tests Continued

U peak or d.c.	V _a r.m.s.	V _b r.m.s.	U peak or d.c.	V _a r.m.s.	V _b r.m.s.	U peak or d.c.	V _a r.m.s.	V _b r.m.s.
72	708	1 133	540	1 803	2 885	3 800	5 507	5 507
74	717	1 147	560	1 834	2 934	4 000	5 702	5 702
76	726	1 162	580	1 864	2 982	4 200	5 894	5 894
78	735	1 176	588	1 875	3 000	4 400	6 082	6 082
80	744	1 190	600	1 893	3 000	4 600	6 268	6 268
85	765	1 224	620	1 922	3 000	4 800	6 452	6 452
90	785	1 257	640	1 951	3 000	5 000	6 633	6 633
95	805	1 288	660	1 979	3 000	5 200	6 811	6 811
100	825	1 319	680	2 006	3 000	5 400	6 987	6 987
105	844	1 350	700	2 034	3 000	5 600	7 162	7 162
110	862	1 379	720	2 060	3 000	5 800	7 334	7 334
115	880	1 408	740	2 087	3 000	6 000	7 504	7 504
120	897	1 436	760	2 113	3 000	6 200	7 673	7 673
125	915	1 463	780	2 138	3 000	6 400	7 840	7 840
130	931	1 490	800	2 164	3 000	6 600	8 005	8 005
135	948	1 517	850	2 225	3 000	6 800	8 168	8 168
140	964	1 542	900	2 285	3 000	7 000	8 330	8 330
145	980	1 568	950	2 343	3 000	7 200	8 491	8 491
150	995	1 593	1 000	2 399	3 000	7 400	8 650	8 650
152	1 000	1 600	1 050	2 454	3 000	7 600	8 807	8 807
1) 155	1 000	1 617	1 100	2 508	3 000	7 800	8 964	8 964
1) 160	1 000	1 641	1 150	2 560	3 000	8 000	9 119	9 119
1) 165	1 000	1 664	1 200	2 611	3 000	8 200	9 273	9 273
1) 170	1 000	1 688	1 250	2 661	3 000	8 400	9 425	9 425
1) 175	1 000	1 711	1 300	2 710	3 000	8 600	9 577	9 577
1) 180	1 000	1 733	1 350	2 758	3 000	8 800	9 727	9 727
1) 184	1 000	1 751	1 400	2 805	3 000	9 000	9 876	9 876
185	1 097	1 755	1 410	2 814	3 000	9 200	10 024	10 024
190	1 111	1 777	1 450	2 868	3 000	9 400	10 171	10 171
200	1 137	1 820	1 500	2 934	3 000	9 600	10 317	10 317
210	1 163	1 861	1 550	3 000	3000	9 800	10 463	10 463
220	1 189	1 902	1 600	3 065	3 065	10 000	10 607	10 607
230	1 214	1 942	1 650	3 130	3 130			
240	1 238	1 980	1 700	3 194	3 194			

1) At these voltages, the values of V_b are determined by the general curve $V_b = 155,86 U^{0,4638}$ and are not 1,6 V_a.

2) Linear interpolation is permitted between adjacent points in the table.

5.3 Abnormal operating and fault conditions

NAD

5.3.1 Protection against overload and abnormal operation

Equipment shall be so designed that the risk of fire or electric shock due to mechanical or electrical overload or failure, or due to abnormal operation or careless use, is limited as far as practicable.

After abnormal operation or a single fault (see 1.4.14), the equipment shall remain safe for an OPERATOR in the meaning of this standard, but it is not required that the equipment should still be in full working order. It is permitted to use fusible links, THERMAL CUT-OUTS, overcurrent protection devices and the like to provide adequate protection.

Compliance is checked by inspection and by the tests of 5.3. Before the start of each test, it is checked that the equipment is operating normally.

If a component or subassembly is so enclosed that short-circuiting or disconnection as specified in 5.3 is not practicable or is difficult to perform without damaging the equipment, it is permitted to make the tests on sample parts provided with special connecting leads. If this is not possible or not practical, the component or subassembly as a whole shall pass the tests.

Equipment is tested by applying any condition that may be expected in normal use and foreseeable misuse.

In addition, equipment which is provided with a protective covering is tested with the covering in place under normal idling conditions until steady conditions are established.

5.3.2 Motors

B

Under overload, locked rotor and other abnormal conditions, motors shall not cause hazard because of excessive temperatures.

NOTE – Methods of achieving this include the following:

- the use of motors which do not overheat under locked-rotor conditions (protection by inherent or external impedance);
- the use in SECONDARY CIRCUITS of motors which may exceed the permitted temperature limits but which do not create a hazard;
- the use of a device responsive to motor current;
- the use of an integral THERMAL CUT-OUT;
- the use of a sensing circuit which disconnects power from the motor in a sufficiently short time to prevent overheating if, for example, the motor fails to perform its intended function.

Compliance is checked by the applicable tests of annex B.

5.3.3 Transformers

P

Transformers shall be protected against overload, for example by:

C

- overcurrent protection;
- internal THERMAL CUT-OUTS;
- use of current limiting transformers.

Compliance is checked by the applicable tests of clause C.1.

5.3.4 Functional insulation

For FUNCTIONAL INSULATION, CLEARANCES and CREEPAGE DISTANCES shall satisfy one of the following requirements a), b) or c).

For insulation between a SECONDARY CIRCUIT and an inaccessible conductive part that is earthed for functional reasons, CLEARANCES and CREEPAGE DISTANCES shall also satisfy a), b) or c).

- a) They meet the CLEARANCE and CREEPAGE DISTANCES requirements for FUNCTIONAL INSULATION in 2.10; or
- b) they withstand the electric strength tests for FUNCTIONAL INSULATION in 5.2.2; or
- c) they are short-circuited where a short-circuit could cause:
 - overheating of any material creating a risk of fire, unless the material that could be overheated is FLAMMABILITY CLASS V-1 or better, or
 - thermal damage to BASIC INSULATION, SUPPLEMENTARY INSULATION OR REINFORCED INSULATION, thereby creating a risk of electric shock.

Compliance criteria for 5.3.4 c) are in 5.3.8.

5.3.5 Electromechanical components

In *SECONDARY CIRCUITS*, where a hazard is likely to occur, electromechanical components other than motors are checked for compliance with 5.3.1 by applying the following conditions:

- mechanical movement shall be locked in the most disadvantageous position while the component is energized normally;
- in the case of a component which is normally energized intermittently, a fault shall be simulated in the drive circuit to cause continuous energizing of the component.

The duration of each test shall be as follows:

- for equipment or components whose failure to operate is not evident to the OPERATOR: as long as necessary to establish steady conditions or up to the interruption of the circuit due to other consequences of the simulated fault condition, whichever is the shorter; and
- for other equipment and components: 5 min or up to interruption of the circuit due to a failure of the component (e.g. burn-out) or to other consequences of the simulated fault condition, whichever is the shorter.

For compliance criteria see 5.3.8.

5.3.6 Simulation of faults

For components and circuits other than those covered by 5.3.2, 5.3.3 and 5.3.5, compliance is checked by simulating fault conditions (see 1.4.14).

The following faults are simulated:

- a) faults in any components in *PRIMARY CIRCUITS*; and
- b) faults in any components where failure could adversely affect *SUPPLEMENTARY INSULATION OR REINFORCED INSULATION*; and
- c) for components and parts that do not comply with the requirements of 4.7.3, faults, including overload, in all relevant components and parts; and
- d) faults arising from connection of the most unfavourable load impedance to terminals and connectors that deliver power or signal outputs from the equipment, other than mains power outlets; and
- e) overloading of internal (i.e. card cage) SELV CIRCUIT connectors and printed wiring board connectors, or both, that are accessible to the operator. The connectors shall be connected to a resistive load which draws the maximum available output current. The maximum available output current shall be:
 - (1) that current which is just below the trip point of any overcurrent or overtemperature protective device. The trip point of an overcurrent protective device shall be considered to be 110 % of its current rating; or
 - (2) the maximum available output current.

D2
D2
D2
D2
D2
D2
D2
D2

Where there are multiple outlets having the same internal circuitry, the test is only made on one sample outlet. D2
D2

Circuits and connectors supplied by the following sources need not be subjected to the tests described in c) through e) above: D2
D2

– a limited power source: D2

– a source inherently limited to only the output voltage and current values specified in table 2B: D2
D2

– a source limited to only the output voltage and current values provided with an overcurrent protective device as specified in table 2C. D2
D2

For PRIMARY CIRCUITS where there is 10 000 Ω or more of additional series impedance in a circuit in which the voltage is 125 V or less, the circuit need not be subjected to the test. D2
D2

For PRIMARY CIRCUITS where there is 20 000 Ω or more of additional series impedance in a circuit in which the voltage is greater than 125 V but is not greater than 250 V, the circuit need not be subjected to the test. D2
D2
D2

If the circuit is interrupted by the opening of a component, the test is to be repeated twice (three tests total), using new components as necessary. D2
D2

For components in PRIMARY CIRCUITS associated with the mains input, such as the supply cord, appliance couplers, EMC filtering components, switches and their interconnecting wiring, no fault is simulated, provided that the component complies with 5.3.4 a).

NOTE – Such components are still subject to other requirements of this standard where applicable, including 1.5.1, 2.10.5, 4.4.3 and 5.2.2.

In addition to the compliance criteria given in 5.3.8, temperatures in the transformer supplying the component under test shall not exceed those specified in clause C.1, and account shall be taken of the exception detailed in clause C.1 regarding transformers that would require replacement.

5.3.7 Unattended equipment

K

Equipment intended for unattended use and having THERMOSTATS, TEMPERATURE LIMITERS and THERMAL CUT-OUTS, or having a capacitor not protected by a fuse or the like connected in parallel with the contacts, is subjected to the following tests.

P

THERMOSTATS, TEMPERATURE LIMITERS and THERMAL CUT-OUTS are also assessed for compliance with the requirements in clause K.6.

Equipment is operated under the conditions specified in 4.5.1 and any control that serves to limit the temperature is short-circuited. If the equipment is provided with more than one THERMOSTAT, TEMPERATURE LIMITER OR THERMAL CUT-OUT, each is short-circuited, one at a time.

If interruption of the current does not occur, the equipment is switched off as soon as steady conditions are established and is permitted to cool down to approximately room temperature.

For equipment rated for only SHORT-TIME OPERATION, the duration of the test is equal to the RATED OPERATING TIME.

For equipment rated for SHORT-TIME OR INTERMITTENT OPERATION, the test is repeated until steady state conditions are reached, irrespective of the RATED OPERATING TIME. For this test the THERMOSTATS, TEMPERATURE LIMITERS OR THERMAL CUT-OUTS are not short-circuited.

If in any test a MANUAL-RESET THERMAL CUT-OUT operates, or if the current is otherwise interrupted before steady conditions are reached, the heating period is taken to have ended; but if the interruption is due to the rupture of an intentionally weak part, the test is repeated on a second sample. Both samples shall comply with the conditions specified in 5.3.8.

5.3.8 Compliance criteria for abnormal operating and fault conditions

5.3.8.1 During the tests

During the tests of 5.3.4 c), 5.3.5, 5.3.6 and 5.3.7:

- if a fire occurs it shall not propagate beyond the equipment; and*
- the equipment shall not emit molten metal; and*
- if a wire or a printed wiring board trace in the PRIMARY CIRCUIT opens, the gap is to be electrically shorted and the test continued until ultimate results occur. This applies to each occurrence;* D2
D2
D2
- if a trace in a secondary circuit is designed to intentionally open in a repeatable manner, the test is to be conducted three times to determine if the circuit does open repeatedly;* D2
D2
D2
- ENCLOSURES shall not deform in such a way as to cause non-compliance with 2.1.1, 2.6.1, 2.10.3 and 4.4.1.*

Moreover, during the tests of 5.3.6 c), unless otherwise specified, the temperature rises of insulating materials other than thermoplastic materials shall not exceed 125 K for Class A, 140 K for Class E, 150 K for Class B, 165 K for Class F, and 185 K for Class H materials.

If the failure of the insulation would not result in HAZARDOUS VOLTAGES OR HAZARDOUS ENERGY LEVELS becoming accessible, a maximum temperature of 300 °C is permitted. Higher temperatures are permitted for insulation made of glass or ceramic material.

5.3.8.2 After the tests

After the tests of 5.3.4 c), 5.3.5, 5.3.6 and 5.3.7, an electric strength test is made on:

- REINFORCED INSULATION; and*
- BASIC INSULATION OR SUPPLEMENTARY INSULATION forming part of DOUBLE INSULATION; and*
- BASIC INSULATION between the PRIMARY CIRCUIT and accessible conductive parts of CLASS I EQUIPMENT;*

if any of the following applies:

- the CLEARANCE OR CREEPAGE DISTANCE has been reduced below the value specified in 2.10; or*
- the insulation shows visible signs of damage; or*
- the insulation cannot be inspected.*

This test is made as specified in 5.2.2.

6 Connection to telecommunication networks

NAA

If the equipment is to be connected to a TELECOMMUNICATION NETWORK, the requirements of clause 6 apply in addition to the other requirements in this standard.

NOTE 1 – It is assumed that adequate measures according to ITU-T Recommendation K.11 have been taken to reduce the likelihood that the overvoltages presented to the equipment exceed 1,5 kV peak. In installations where overvoltages presented to the equipment may exceed 1,5 kV peak, additional measures such as surge suppression may be necessary.

NOTE 2 – Legal requirements may exist regarding the connection of information technology equipment to a TELECOMMUNICATION NETWORK operated by a public network operator.

NOTE 3 – The requirements of 2.3.2, 6.1.2 and 6.2 can apply to the same physical insulation OF CLEARANCE.

NOTE 4 – The mains power supply system, if used as a telecommunication transmission medium, is not a TELECOMMUNICATION NETWORK (see 1.2.13.8), and clause 6 does not apply. The other clauses of this standard will apply to coupling components, such as signal transformers, connected between the mains and other circuitry. The requirements for DOUBLE INSULATION OF REINFORCED INSULATION will generally apply.

6.1 Protection of telecommunication network service personnel, and users of other equipment connected to the network, from hazards in the equipment

6.1.1 Protection from hazardous voltages

Circuitry intended to be directly connected to a TELECOMMUNICATION NETWORK shall comply with the requirements for an SELV CIRCUIT or a TNV CIRCUIT.

Where protection of the TELECOMMUNICATION NETWORK relies on the protective earthing of the equipment, the installation instructions and other relevant literature shall state that integrity of protective earthing must be ensured (see also 1.7.2).

Compliance is checked by inspection and measurement.

6.1.2 Separation of the telecommunication network from earth

6.1.2.1 Requirements

Except as specified in 6.1.2.2, there shall be insulation between circuitry intended to be connected to a TELECOMMUNICATION NETWORK and any parts or circuitry that will be earthed in some applications, either within the EUT or via other equipment.

Surge suppressors that bridge the insulation shall have a minimum d.c. sparkover voltage of 1,6 times the RATED VOLTAGE or 1,6 times the upper voltage of the RATED VOLTAGE RANGE of the equipment. If left in place during electric strength testing of the insulation, they shall not be damaged.

NOTE 1 – In Sweden, for PLUGGABLE EQUIPMENT TYPE A, SUPPLEMENTARY INSULATION for PRIMARY CIRCUIT is required between the TELECOMMUNICATION NETWORK and any parts or circuitry that may be earthed. This note does not apply to the equipment in the second dashed paragraph of 6.1.2.2 and the equipment which needs connection to earth to enable it to function and has a marking stating that safety requirements are not fulfilled unless the equipment is connected to a wall socket-outlet with protective earth contact.

NOTE 2 – In Norway, due to the IT power distribution system used (see annex V, figure V.7), SUPPLEMENTARY INSULATION for a PRIMARY CIRCUIT is required between any circuit intended for connection to a TELECOMMUNICATION NETWORK (SELV and/or TNV) and any circuit that has a connection to a protective earth terminal.

This requirement does not apply to:

- PERMANENTLY CONNECTED EQUIPMENT;
- PLUGGABLE EQUIPMENT TYPE B;
- equipment intended to be installed in areas where the possibility of rise of earth potential has been reduced to a level where electric shock is unlikely (equipotential bonding), e.g. in a telecommunication central office.

Compliance is checked by inspection and by the following tests.

Insulation is subjected to an electric strength test according to 5.2.2. The a.c. test voltage is as follows:

- *for equipment intended to be installed in an area where the nominal AC MAINS SUPPLY voltage exceeds 130 V: 1,5 kV*
- *for all other equipment: 1,0 kV*

The test voltages apply whether or not the equipment is powered from the AC MAINS SUPPLY.

It is permitted to remove components that bridge the insulation, other than capacitors, during electric strength testing. If this option is chosen, an additional test with a test circuit according to figure 6A is performed with all components in place. The test is performed with a voltage equal to the RATED VOLTAGE of the equipment or to the upper voltage of the RATED VOLTAGE RANGE.

During these tests:

- there shall be no breakdown of insulation during electric strength testing; and*
- components bridging the insulation that are left in place during electric strength testing shall not be damaged; and*
- the current flowing in the test circuit of figure 6A shall not exceed 10 mA*

6.1.2.2 Exclusions

The requirements of 6.1.2.1 do not apply to any of the following:

- PERMANENTLY CONNECTED EQUIPMENT OR PLUGGABLE EQUIPMENT TYPE B;
- equipment that is intended to be installed by SERVICE PERSONNEL and has installation instructions that require the equipment to be connected to a socket-outlet with a protective earthing connection (see 6.1.1);
- equipment that has provision for a permanently connected PROTECTIVE EARTHING CONDUCTOR and is provided with instructions for the installation of that conductor.

NOTE – In Finland and Norway, the exclusions are applicable for PERMANENTLY CONNECTED EQUIPMENT and PLUGGABLE EQUIPMENT TYPE B only.

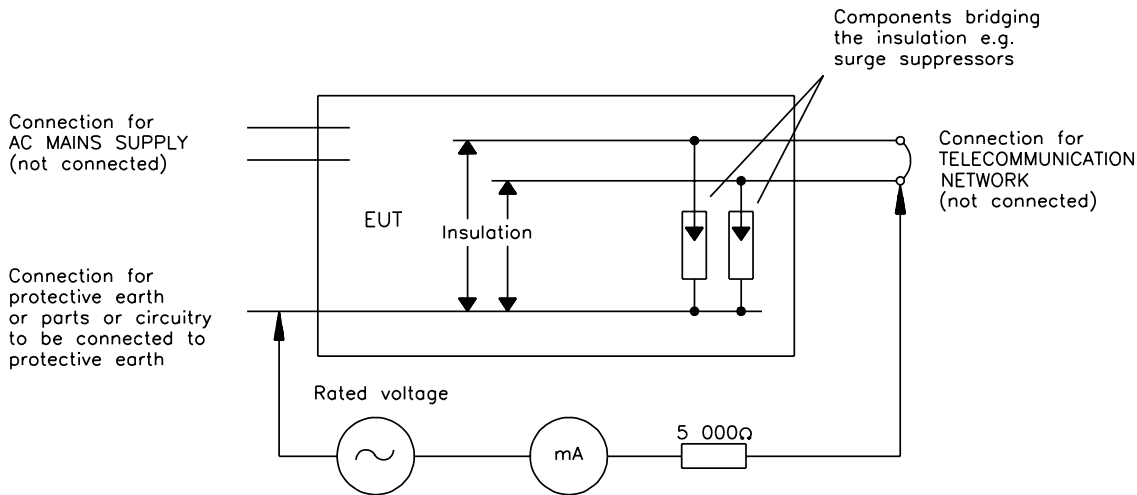

SM431D

Figure 6A – Test for separation between a telecommunication network and earth

6.2 Protection of equipment users from overvoltages on telecommunication networks

6.2.1 Separation requirements

Equipment shall provide adequate electrical separation between a TNV-1 CIRCUIT or a TNV-3 CIRCUIT and certain parts of the equipment. These parts are:

- a) unearthed conductive parts and nonconductive parts of the equipment expected to be held or touched during normal use (e.g. a telephone handset or a keyboard); and
- b) parts and circuitry that can be touched by the test finger, of figure 2A (see 2.1.1.1), except contacts of connectors that cannot be touched by the test probe, of figure 2C (see 2.1.1.1); and
- c) circuitry which is provided for connection of other equipment, and telecommunication circuitry (other than earth) intentionally isolated from TELECOMMUNICATION NETWORK conductors. The requirement for separation applies whether or not this circuitry is accessible. It does not apply to circuitry intended to be connected to another equipment that is itself in compliance with 6.2. D2
D2
D2

Digital equipment or dedicated systems of equipment that perform a digital line termination (such as NCTE and NT1) or similar function shall not conductively connect the TELECOMMUNICATION NETWORK to terminal equipment leads [point (c) above], and shall comply with these requirements. D2
D2
D2

Enamel coating on signal transformer winding wire may be used to provide electrical separation only if the wire complies with the component requirements for magnet wire, and the transformer is subjected to a 1 000 V a.c. electric strength test without evidence of dielectric breakdown as a ROUTINE TEST on 100 % of production. (See 2.3.2.) D2
D2
D2
D2

These requirements do not apply where circuit analysis and equipment investigation indicate that safety is assured by other means, for example, between two circuits each of which has a permanent connection to protective earth.

Compliance is checked by the tests of 6.2.2. The requirements of 2.10 regarding the dimensions and construction of CLEARANCE, CREEPAGE DISTANCE and solid insulation do not apply for compliance with 6.2.1.

NOTE – The requirements of 2.10 may apply for compliance with 2.2 and 2.3. See items 5) and 6) of table 2G.

6.2.2 Electric strength test procedure

Compliance with 6.2.1 is checked by the test of either 6.2.2.1 or 6.2.2.2.

NOTE – In Australia, the tests of both 6.2.2.1 and 6.2.2.2 apply.

If a test is applied to a component (see 1.4.3), for example a signal transformer, which is clearly intended to provide the separation required, the component shall not be bypassed by other components, mounting devices or wiring, unless these components or wiring also meet the separation requirements of 6.2.

For the tests, all conductors intended to be connected to the TELECOMMUNICATION NETWORK are connected together (see figure 6B), including any conductors required by the TELECOMMUNICATION NETWORK authority to be connected to earth. Similarly, all conductors intended to be connected to other equipment are connected together in 6.2.1 c).

Non-conductive parts are tested with metal foil in contact with the surface. Where adhesive metal foil is used, the adhesive shall be conductive.

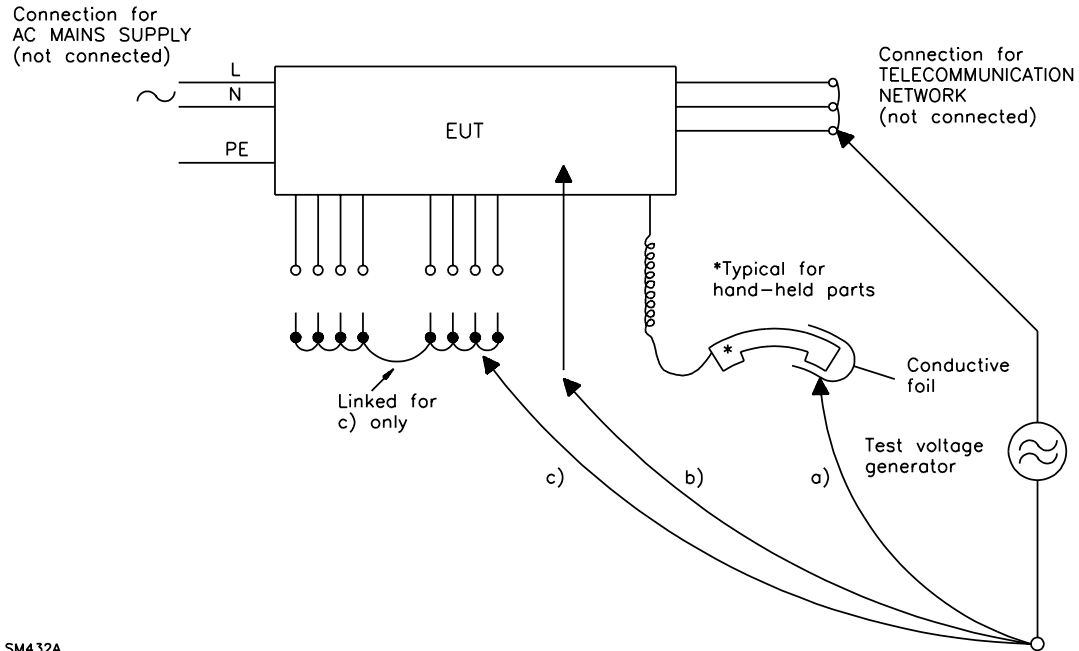

Figure 6B – Application points of test voltage

6.2.2.1 Impulse test

N

The electrical separation is subjected to 10 impulses of alternating polarity, using the impulse test generator of annex N for 10/700 μ s impulses. The interval between successive impulses is 60 s and the initial voltage, U_C , is:

- for 6.2.1 a): 2,5 kV; and
- for 6.2.1 b) and 6.2.1 c): 1,5 kV.

NOTE 1 – The value of 2,5 kV for 6.2.1 a) has been chosen primarily to ensure the adequacy of the insulation concerned and it does not necessarily simulate likely overvoltages.

NOTE 2 – In Australia, a value of $U_C = 7,0$ kV is used in 6.2.1 a).

6.2.2.2 Steady-state test

The electrical separation is subjected to an electric strength test according to 5.2.2.

The a.c. test voltage is:

- for 6.2.1 a): 1,5 kV; and
- for 6.2.1 b) and 6.2.1 c): 1,0 kV.

NOTE – In Australia, a value of 3,0 kV is used in 6.2.1 a) for hand-held telephones and headsets and 2,5 kV for other equipment, to simulate lightning surges on typical rural and semi rural network lines. A value of 1,5 kV is used in 6.2.1 b) and c).

For 6.2.1 b) and 6.2.1 c), it is permitted to remove surge suppressors, provided that such devices pass the impulse test of 6.2.2.1 for 6.2.1 b) and 6.2.1 c) when tested as components outside the equipment. For 6.2.1 a), surge suppressors shall not be removed.

6.2.2.3 Compliance criteria

S

During the tests of 6.2.2.1 and 6.2.2.2, there shall be no breakdown of insulation.

Insulation breakdown is considered to have occurred when the current which flows as a result of the application of the test voltage rapidly increases in an uncontrolled manner, i.e. the insulation does not restrict the flow of current.

If a surge suppressor operates (or sparkover occurs within a gas discharge tube) during the test:

- for 6.2.1 a), such operation represents a failure; and
- for 6.2.1 b) and 6.2.1 c), such operation is permitted during the impulse test; and
- for 6.2.1 b) and 6.2.1 c), such operation during the electric strength test (by any surge suppressor left in place) represents a failure.

For impulse tests, damage to insulation is verified in one of two ways, as follows:

- during the application of the impulses, by observation of oscillograms. Surge suppressor operation or breakdown through insulation is judged from the shape of an oscillogram.
- after application of all the impulses, by an insulation resistance test. Disconnection of surge suppressors is permitted while insulation resistance is being measured. The test voltage is 500 V d.c. or, if surge suppressors are left in place, a d.c. test voltage that is 10 % less than the surge suppressor operating or striking voltage. The insulation resistance shall not be less than 2 M Ω .

NOTE – A description of procedures to judge whether a surge suppressor operation or breakdown of insulation has occurred, using oscillograms, is given in annex S.

6.3 Protection of the telecommunication wiring system from overheating

P
NAA

Equipment intended to provide power over the telecommunication wiring system to remote equipment shall limit the output current to a value that does not cause damage to the telecommunication wiring system, due to overheating, under any external load condition. The maximum continuous current from equipment shall not exceed a current limit that is suitable for the minimum wire gauge specified in the equipment installation instructions. The current limit is 1,3 A if such wiring is not specified.

NOTE 1 – The overcurrent protective device may be a discrete device such as a fuse, or a circuit that performs that function.

NOTE 2 – The minimum wire diameter normally used in telecommunications wiring is 0,4 mm, for which the maximum continuous current for a multipair cable is 1,3 A. This wiring is not usually controlled by the equipment installation instructions, since the wiring is often installed independent of the equipment installation.

NOTE 3 – Further current limitation may be necessary for equipment intended for connection to networks which are subject to overvoltages, due to operating parameters for protective devices.

Compliance is checked as follows.

If current limiting is due to the inherent impedance of the power source, the output current into any resistive load, including a short circuit, is measured. The current limit shall not be exceeded after 60 s of test.

If current limiting is provided by an overcurrent protective device having a specified time/current characteristic:

- the time/current characteristic shall show that a current equal to 110 % of the current limit will be interrupted within 60 min; and*

NOTE 4 – Time/current characteristics of type gD and type gN fuses specified in IEC 60269-2-1 comply with the above limit. Type gD or type gN fuses rated 1 A, would meet the 1,3 A current limit.

- the output current into any resistive load, including a short circuit, with the overcurrent protective device bypassed, measured after 60 s of test, shall not exceed $1\ 000/U$, where U is the output voltage measured in accordance with 1.4.5 with all load circuits disconnected.*

If current limiting is provided by an overcurrent protective device that does not have a specified time/current characteristic:

- the output current into any resistive load, including a short circuit, shall not exceed the current limit after 60 s of test; and*
- the output current into any resistive load, including a short circuit, with the overcurrent protective device bypassed, measured after 60 s of test, shall not exceed $1\ 000/U$, where U is the output voltage measured in accordance with 1.4.5 with all load circuits disconnected.*

Where a fuse is used to provide current limiting in accordance with 6.3, it shall not be operator-accessible unless it is not readily interchangeable.

D2
D2

6.4 Protection against overvoltage from power line crossesD2 **P**

Equipment intended for connection to a TELECOMMUNICATION NETWORK that uses outside cable subject to overvoltage from power line failures shall comply with the construction requirements, test conditions or combination thereof as shown in figure 6C.

D2 **NAA**
D2 **NAC**
D2

NOTE 1 – In figure 6C, “Pass 1, 2, 3, 4 or 5” means compliance with Test Condition 1, 2, 3, 4 or 5, respectively, of annex NAC.

D2

NOTE 2 – It is assumed that the following overvoltage conditions can be encountered on TELECOMMUNICATION NETWORKS that connect to outside cable. The overvoltage is the result of a) contact with a multi-earthed neutral distribution power line (4 kV to approximately 50 kV), b) induction from a distribution power line fault to earth, c) earth potential rise from a distribution power line fault current flowing to earth, and d) contact with 120 V power line.

D2
D2
D2
D2

Maximum longitudinal voltage of 600 V can occur on inside wiring that is protected with 3-mil carbon blocks. Asymmetrical operation of the carbon blocks can result in a metallic voltage of up to 600 V when the longitudinal voltage is high enough to operate one carbon block but not the other (minimum 285 V peak).

D2
D2
D2
D2

Maximum induced current of 2.2 A, steady state, can result from a high impedance power line fault to earth.

D2
D2

Maximum 7 A for 5 s can result from induction or from earth potential rise after a power line contact with a multi-earthed neutral conductor.

D2
D2

An I^2t of 2 400 can result from power line contact with a telephone shielded cable. A combination of 40 A, 1.5 s is considered worst case. I^2t is used for current limits in adiabatic heating processes.

D2
D2
D2

A 120 V power line crossed with a telephone line can deliver up to 25 A to the telephone wiring, limited by the wiring impedance.

D2
D2

Compliance with the construction requirements is checked by inspection. Compliance with the test conditions is checked by the requirements in annex NAC.

D2
D2

<u>Conditions applicable to figure 6C:</u>	D2
1) <u>Equipment contains a method for limiting current energy to 100 A²-s max. for Test Condition 1. A circuit or component that complies with the Standard for Secondary Protectors for Communication Circuits, UL 497A, or CSA C22.2 No. 226, Protectors in Telecommunication Networks, is considered to comply with this requirement.</u>	D2 D2 D2 D2
2) <u>Equipment contains a method for limiting current to 1,3 A max. steady state (e.g. a fuse rated 1,0 A maximum) that also complies with the Standard for Secondary Protectors for Communication Circuits, UL 497A, or CSA C22.2 No. 226, Protectors in Telecommunication Networks.</u>	D2 D2 D2
3) <u>Minimum No. 26 AWG telecommunication line cord, either supplied with the equipment or described in the safety instructions. See annex NAA.</u>	D2 D2
4) <u>The telephone line is adequately isolated from earth for the operating mode being considered at a voltage of 120 V. This may be determined by complying with the test of 6.1.2, figure 6A, using a minimum voltage of 120 V, or an electric strength test of 120 V. The test is applicable to PLUGGABLE EQUIPMENT TYPE A, PLUGGABLE EQUIPMENT TYPE B and PERMANENTLY CONNECTED EQUIPMENT.</u>	D2 D2 D2 D2
5) <u>In addition to the requirements for a FIRE ENCLOSURE, including consideration of HAI (A.3) and HWI (A.4), both of the following requirements apply for parts in TNV CIRCUITS that might ignite under overvoltage conditions:</u>	D2 D2 D2
a) <u>the parts are separated from internal materials of FLAMMABILITY CLASS V-2 or lower by at least 25 mm of air or a barrier of FLAMMABILITY CLASS V-1 or better. The exceptions of 4.7.3.4 apply except that 25 mm shall be substituted wherever 13 mm is found.</u>	D2 D2 D2
b) <u>the parts are separated from openings in the top or sides of the ENCLOSURE by at least 25 mm of air or a barrier of FLAMMABILITY CLASS V-1 or better unless the openings comply with one of the following:</u>	D2 D2 D2
= <u>not exceed 5 mm in any direction, or</u>	D2
= <u>not exceed 1 mm in width regardless of length.</u>	D2
6) <u>Test Condition 2 is not required for equipment containing a method for limiting current to 1,3 A max steady state (e.g. a fuse rated 1,0 A maximum).</u>	D2 D2
7) <u>Test Conditions 3 and 4 are not required for equipment whose application (because of system function, design limitations, etc.) is limited to connections to outside cable not exceeding 1 000 m (for example, equipment that connects to ISDN S/T reference points and certain proprietary telephone sets).</u>	D2 D2 D2

6.5 Acoustic testsD2 **P**

The compliance tests described in this subclause require simulation of the TELECOMMUNICATION NETWORK to perform the following functions:

D2
D2

– generation of test signals that produce acoustic output at the telephone receiver,

D2

– generation of ringing signals that activate the alerting device of the telephone, and

D2

– provision of d.c. power superimposed on the above signals.

D2

Examples of simulators are given that are representative of many analog TELECOMMUNICATION NETWORKS. The simulator may consist of discrete components or proprietary equipment, with appropriate analog or digital interfaces for two or four wires.

D2
D2
D2**6.5.1 Acoustic pressure limiting**

D2

These requirements apply to equipment intended to be connected directly or indirectly to a TELECOMMUNICATION NETWORK containing an earphone which is held against or in the ear. The effect on human hearing of impulsive noise or of disturbances which are less than 0,5 s duration is evaluated under 6.5.2. The effect of longer disturbances, such as those which might be produced during tone-type dialing is evaluated under 6.5.3.

D2
D2
D2
D2
D2

For equipment not intended to be connected to a PSTN (such as connected behind a PABX or connected to a digital TELECOMMUNICATION NETWORK), it is permitted to apply a test voltage to the equipment under test that simulates the effect of the PABX interface or the digital TELECOMMUNICATION NETWORK interface between the equipment under test and the PSTN.

D2
D2
D2
D2

These tests are suitable only for closed-type supra-aural and supra-concha earphones which are physically compatible with the IEC 60318 coupler.

D2
D2

NOTE 1 – Measurement methods for handsets or headsets not covered by this requirement are under consideration by the ITU-T (formerly CCITT) in CCITT Draft Recommendation P.57. Terminology for earphones is as defined in P.57.

D2
D2

NOTE 2 – These requirements are based on CCITT Recommendation P.36, which assumes a 2 s exposure for long duration disturbances and no more than one incident per day. Authorities may deem it appropriate to use lower limits for specific cases, for instance for the headsets used by operators.

D2
D2
D2

NOTE 3 – A PABX or digital TELECOMMUNICATION NETWORK termination may block network voltages, in which case no test voltage is applied. However, signals that can be generated by the system should be considered.

D2
D2

6.5.2 Short duration impulses

D2

The peak acoustic pressure measured at the earpiece of the telephone handset or headset shall be limited to reduce the risk of permanent hearing damage due to short duration impulses (≤ 0.5 s) that may occur under normal operation.

D2

D2

D2

Compliance is checked by the following tests. The handset or headset is placed under normal operating conditions in position for the exchange of calls (such as talking state with the handset raised), and fixed to an artificial ear conforming to the requirements of IEC 60318. The earpiece is sealed to the knife-edge of the artificial ear. Holes in the earpiece which partially fall outside the knife-edge of the artificial ear are sealed. Response for insert type earphones is to be measured with an in-ear coupler as indicated in the American National Standard for Occluded Ear Simulator, ANSI S3.25-1979, extended by an ear canal simulator consisting of a cylinder 8 mm long and 7.5 mm in diameter. The tip of the earphone is inserted until tangent with plane X-X' shown in Figure 1 of ANSI S3.25. The artificial ear is electrically connected to a precision sound level meter conforming with IEC 60651, with an unweighted peak-hold response and capable of measuring impulses having a duration less than 50 μ s.

D2

D2

D2

D2

D2

D2

D2

D2

D2

D2

D2

The equipment under test is connected to a network simulator and impulse generator as shown in figure 6D, by closing switches A and B. An equivalent network simulator may be used.

D2

D2

One positive and one negative polarity impulse is applied to the equipment under test with $U_c = 1$ kV. For analog equipment, the impulses are applied to the receive circuit. For digital equipment, the impulses are applied to both the transmit and receive circuits. In addition, the equipment is checked for self-generated acoustic impulses such as those produced by operation of the hook switch or by dialing.

D2

D2

D2

D2

D2

D2

During the above tests, the peak acoustic pressure level measured in the artificial ear or coupler shall not exceed 136 dB (relative to 20 μ Pa).

D2

D2

6.5.3 Long duration disturbances

D2

The maximum steady-state A-weighted sound pressure measured at the earpiece of the telephone handset or headset shall be limited to reduce the risk of permanent hearing damage due to long duration disturbances (> 0.5 s) that may occur under normal operation.

D2

D2

D2

NOTE 1 – Typical signals considered are alerting (ringing) signals during the on-hook operating condition; and tone-type dialing, network signals and other similar signals generated within the device which can cause excessive acoustic output during the off-hook operating condition.

D2

D2

D2

Compliance is checked by the following tests. The handset or headset is placed under normal operating conditions in position for the exchange of calls (such as talking state or ringing state with the handset raised) and fixed to an artificial ear conforming to the requirements of IEC 60318. The earpiece is sealed to the knife-edge of the artificial ear. Holes in the earpiece which partially fall outside the knife-edge of the artificial ear are sealed. Response for insert type earphones is to be measured with an in-ear coupler as indicated in the American National Standard for Occluded Ear Simulator, ANSI S3.25-1979, extended by an ear canal simulator consisting of a cylinder 8 mm long and 7.5 mm in diameter. The tip of the earphone is inserted until tangent with plane X-X' shown in Figure 1 of ANSI S3.25. The artificial ear is electrically connected to a precision sound level meter conforming with IEC 60651, with A-weighted slow response.

D2

D2

D2

D2

D2

D2

D2

D2

D2

D2

D2

D2

An off-hook signal source as described below is applied to the receive circuit of the equipment under test. The amplitude and frequency is adjusted to produce the maximum acoustic output from the earpiece. D2
D2
D2

An on-hook signal source as described below is applied to the receive circuit of the equipment under test that contains an alerting device in the handset. The ringing frequency is adjusted to produce the maximum acoustic output from the earpiece. D2
D2
D2

NOTE 2 – Ringers that port their output through holes in a handset can produce excessive acoustic output. Measurement techniques for this case are under study. D2
D2

Off-hook signal source D2

The equipment under test is connected to a network simulator and test tone generator as shown in figure 6D, by closing switches A and D. An equivalent network simulator may be used. D2
D2
D2

The analog signal generator in the simulator circuit produces a sine-wave signal. For the equipment under test with a digital interface, a digital sequence representing minimum to maximum transition square wave at frequencies between 300 Hz and 5 000 Hz may be used. D2
D2
D2
D2

On-hook signal source D2

The equipment under test is connected to a network simulator and ringing generator as shown in figure 6D, by closing switches A and C. An equivalent network simulator may be used. A signal generator in the simulator circuit produces a sine-wave signal. For an equipment under test with a digital interface, a digital sequence which will activate the alerting device at its maximum acoustic output may be used. D2
D2
D2
D2
D2

In addition, the equipment is checked for self-generated acoustic disturbances, such as tone dialing signals fed back to the receiver and paging signals sent to a cordless handset. D2
D2

During the above tests, the maximum steady-state A-weighted sound pressure coming from the earphones shall not exceed 125 dBA for handsets, 118 dBA for headsets, and 121 dBA for insert earphones. D2
D2
D2

Annex A
(normative)
Tests for resistance to heat and fire

It should be noted that toxic fumes may be given off during the tests. Where appropriate the tests should be carried out either under a ventilated hood or in a well-ventilated room, but free from draughts which could invalidate the tests.

Where the tests use a gas flame, it is permitted to use technical grade methane with a suitable regulator and meter for gas flow, or natural gas having a calorific value of approximately 37 MJ/m³. Technical grade methane has a minimum purity of 98,0 mole % and a typical analysis would be:

	mole %
Methane	98,5
Ethane	0,5
Nitrogen	0,6
Oxygen	0,1
Carbon dioxide	0,1
Propane	0,1
Higher alkanes	0,1

A.1 Flammability test for fire enclosures of movable equipment having a total mass exceeding 18 kg, and of stationary equipment (see 4.7.3.2)

A.1.1 Samples

Three samples, each consisting of either a complete FIRE ENCLOSURE or a section of the FIRE ENCLOSURE representing the thinnest significant wall thickness and including any ventilation opening, are tested.

A.1.2 Conditioning of samples

Prior to being tested, the samples are conditioned in a circulating air oven for a period of 7 days (168 h), at a uniform temperature 10 K higher than the maximum temperature reached by the material measured during the test of 4.5.1, or 70 °C, whichever is the higher, and then cooled to room temperature.

A.1.3 Mounting of samples

Samples are mounted as they would be in actual use. A layer of untreated surgical cotton is located 300 mm below the point of application of the test flame.

A.1.4 Test flame

The test flame is obtained by means of a Bunsen burner whose barrel has an inside diameter of $9,5 \text{ mm} \pm 0,5 \text{ mm}$ and a length of approximately 100 mm above the primary air inlet or inlets. A gas supply of calorific value approximately 37 MJ/m^3 is used and the flame is adjusted so that, while the burner is vertical, the overall height of the flame is approximately 130 mm and the height of the inner blue cone is approximately 40 mm.

A.1.5 Test procedure

The test flame is applied to an inside surface of the sample, at a location judged to be likely to become ignited because of its proximity to a source of ignition. If a vertical part is involved, the flame is applied at an angle of approximately 20° from the vertical. If ventilation openings are involved, the flame is applied to an edge of an opening, otherwise to a solid surface. In all cases, the tip of the inner blue cone is to be in contact with the sample. The flame is applied for 5 s and removed for 5 s. This operation is repeated until the sample has been subjected to five applications of the test flame to the same location.

The test is repeated on the remaining two samples. If more than one part of the FIRE ENCLOSURE is near a source of ignition, each sample is tested with the flame applied to a different location.

A.1.6 Compliance criteria

During the test, the sample shall not release either flaming drops or particles capable of igniting the surgical cotton. The sample shall not continue to burn for more than 1 min after the fifth application of the test flame, and shall not be consumed completely.

A.2 Flammability test for fire enclosures of movable equipment having a total mass not exceeding 18 kg, and for material and components located inside fire enclosures (see 4.7.3.2 and 4.7.3.4)

P

A.2.1 Samples

Three samples are tested. For FIRE ENCLOSURES, each sample consists of either a complete FIRE ENCLOSURE or a section of the FIRE ENCLOSURE representing the thinnest significant wall thickness and including any ventilation opening. For material to be located within the FIRE ENCLOSURE, each sample of the material consists of one of the following:

- the complete part; or
- a section of the part representing the thinnest significant wall thickness; or
- a test plaque or bar of uniform thickness representing the thinnest significant section of the part.

For components to be located within the FIRE ENCLOSURE, each sample is to be a complete component.

A.2.2 Conditioning of samples

Prior to being tested, the samples are conditioned in a circulating air oven for a period of 7 days (168 h), at a uniform temperature 10 K higher than the maximum temperature of the part measured during the test of 4.5.1, or 70 °C, whichever is the higher, and then cooled to room temperature.

A.2.3 Mounting of samples

Samples are mounted and oriented as they would be in actual use.

A.2.4 Test flame

The test flame is obtained by means of a Bunsen burner whose barrel has an inside diameter of 9,5 mm ± 0,5 mm and a length of approximately 100 mm above the primary air inlet or inlets. A gas supply of calorific value approximately 37 MJ/m³ is used and the flame adjusted so that while the burner is vertical, the overall height of the flame is approximately 20 mm, with the air inlet ports closed.

A.2.5 Test procedure

The test flame is applied to an inside surface of the sample at a point judged to be likely to become ignited because of its proximity to a source of ignition. For the evaluation of materials located within the FIRE ENCLOSURE, it is permitted to apply the test flame to an external surface of the sample. For the evaluation of components to be located with the FIRE ENCLOSURE, the test flame is applied directly to the component.

If a vertical part is involved, the flame is applied at an angle of approximately 20° from the vertical. If ventilation openings are involved, the flame is applied to an edge of an opening, otherwise to a solid surface. In all cases, the tip of the flame is to be in contact with the sample. The flame is applied for 30 s and removed for 60 s, then reapplied to the same location for 30 s.

The test is repeated on the remaining two samples. If any part being tested is near a source of ignition at more than one point, each sample is tested with the flame applied to a different point which is near a source of ignition.

A.2.6 Compliance criteria

During the test, the samples shall not continue to burn for more than 1 min after the second application of the test flame, and shall not be consumed completely.

A.2.7 Alternative test

As an alternative to the apparatus and procedure specified in A.2.4 and A.2.5, it is permitted to use the apparatus and procedure specified in IEC 695-2-2: 1991, clauses 4 and 8. The manner, duration and number of flame applications are as specified in A.2.5 and compliance is in accordance with A.2.6.

NOTE: Compliance with the method of either A.2.4 and A.2.5 or of A.2.7 is acceptable; it is not required to comply with both methods.

A.3 High current arcing ignition test (see 4.7.3.2)

A.3.1 Samples

Five samples of each material are used. The samples are 130 mm long minimum by 13 mm wide and of uniform thickness representing the thinnest section of the part. Edges are to be free from burrs, fins, etc.

A.3.2 Test circuit

Each test is made with a pair of test electrodes and a variable inductive impedance load connected in series to a source of 220 V to 240 V a.c., 50 Hz or 60 Hz, see figure A.1.

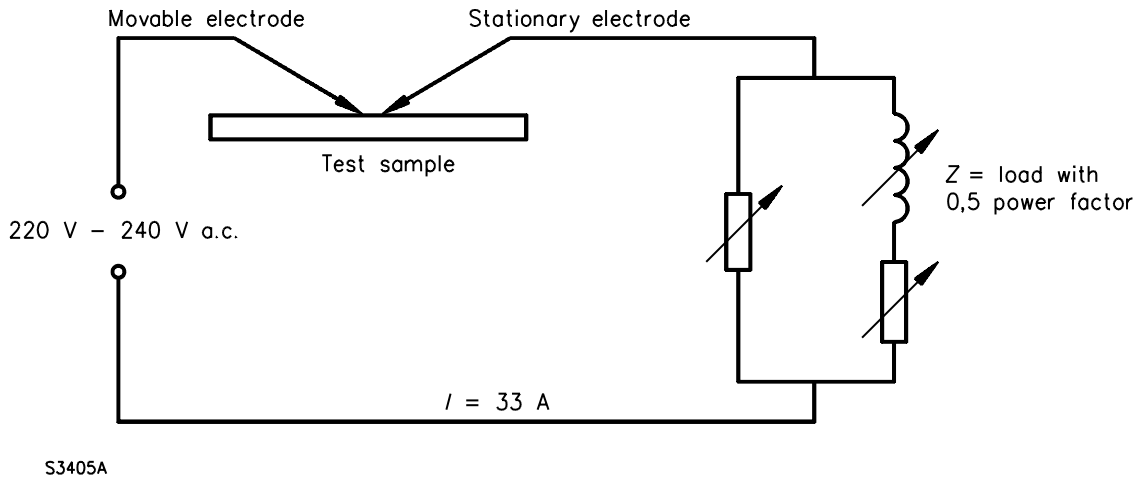

Figure A.1 – Circuit for high current arcing test

It is permitted to use an equivalent circuit.

A.3.3 Test electrodes

One electrode is stationary and the second movable. The stationary electrode consists of a 3,5 mm diameter solid copper conductor having a 30° chisel point. The movable electrode is a 3 mm diameter stainless steel rod with a symmetrical conical point having a total angle of 60° and is capable of being moved along its own axis. The radius of curvature for the electrode tips does not exceed 0,1 mm at the start of a given test. The electrodes are located opposing each other, in the same plane, at an angle of 45° to the horizontal. With the electrodes short-circuited, the variable inductive impedance load is adjusted until the current is 33 A at a power factor of 0,5.

A.3.4 Test procedure

The sample under test is supported horizontally in air or on a non-conductive surface so that the electrodes, when touching each other, are in contact with the surface of the sample. The movable electrode is manually or otherwise controlled so that it can be withdrawn from contact with the stationary electrode to break the circuit and lowered to remake the circuit, so as to produce a series of arcs at a rate of approximately 40 arcs/min, with a separation speed of 254 mm/s \pm 25 mm/s.

The test is continued until ignition of the sample occurs, a hole is burned through the sample or a total of 200 arcs has elapsed.

A.3.5 Compliance criteria

The average number of arcs to ignition of the specimens tested shall not be less than 15 for v-0 CLASS MATERIALS and not less than 30 for other materials.

A.4 Hot wire ignition test (see 4.7.3.2)

A.4.1 Samples

Five samples of each material are tested. The samples are 130 mm long minimum by 13 mm wide and of a uniform thickness representing the thinnest section of the part. Edges are to be free from burrs, fins, etc.

A.4.2 Test circuit

A 250 mm \pm 5 mm length of nichrome wire (nominal composition 80 % nickel, 20 % chromium, iron-free) approximately 0,5 mm diameter and having a cold resistance of approximately 5,28 Ω /m is used. The wire is connected in a straight length to a variable source of power which is adjusted to cause a power dissipation of 0,26 W/mm \pm 4 % in the wire for a period of 8 s to 12 s. After cooling, the wire is wrapped around a sample to form five complete turns spaced 6 mm apart.

A.4.3 Mounting of samples

The wrapped sample is supported in a horizontal position and the ends of the wire connected to the variable power source, which is again adjusted to dissipate 0,26 W/mm \pm 4 % in the wire, see figure A.2.

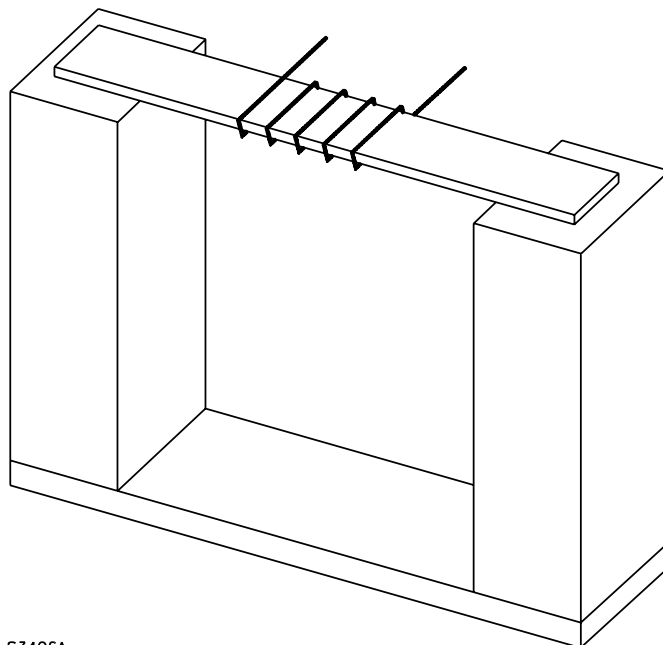

S3406A

Figure A.2 – Test fixture for hot wire ignition test

A.4.4 Test procedure

At the start of the test, the circuit is energized so that a current is passed through the heater wire yielding a linear power density of $0,26 \text{ W/mm} \pm 4 \%$. The test is continued until the test specimen ignites or until 120 s have passed. When ignition occurs or 120 s have passed, the test is discontinued and the test time recorded. For specimens that melt through the wire without ignition, the test is discontinued when the specimen is no longer in intimate contact with all five turns of the heater wire.

The test is repeated on the remaining samples.

A.4.5 Compliance criterion

The average ignition time of the specimens tested shall not be less than 15 s.

A.5 Hot flaming oil test (see 4.6.2)

A.5.1 Mounting of samples

A sample of the complete finished bottom of the FIRE ENCLOSURE is securely supported in a horizontal position. Bleached cheesecloth of approximately 40 g/m² is placed in one layer over a shallow, flat-bottomed pan approximately 50 mm below the sample, and is of sufficient size to cover completely the pattern of openings in the sample, but not large enough to catch any of the oil that runs over the edge of the sample or otherwise does not pass through the openings.

NOTE – Use of a metal screen or a wired-glass partition surrounding the test area is recommended.

A.5.2 Test procedure

A small metal ladle (preferably no more than 65 mm in diameter), with a pouring lip and a long handle whose longitudinal axis remains horizontal during pouring, is partially filled with 10 ml of a distillate fuel oil which is a medium volatile distillate having a mass per unit volume between 0,845 g/ml and 0,865 g/ml, a flash point between 43,5 °C and 93,5 °C and an average calorific value of 38 MJ/l. The ladle containing the oil is heated and the oil ignited and permitted to burn for 1 min, at which time all of the hot flaming oil is poured at the rate of approximately 1 ml/s in a steady stream onto the center of the pattern of openings, from a position approximately 100 mm above the openings.

The test is repeated twice at 5 min intervals, using clean cheesecloth.

A.5.3 Compliance criterion

During these tests the cheesecloth shall not ignite.

A.6 Flammability tests for classifying materials V-0, V-1 or V-2

P

A.6.1 Samples

Ten samples of a material or assembly intended to be classified V-0, V-1 or V-2 CLASS MATERIAL are tested as indicated below.

Material test samples are approximately 130 mm long by 13 mm wide, and of the smallest thickness used. For sound-deadening material other than foamed plastic, which is normally attached to a panel of another material, it is permitted to use samples consisting of the material attached to a panel of the smallest thickness used. For testing an assembly, it is permitted to use samples consisting of the assembly, or a portion thereof not smaller than the dimensions specified for a material sample. It is permitted either to test gears, cams, belts, bearings, tubing, wiring harness, etc., as finished parts, or to test samples cut from finished parts.

A.6.2 Conditioning of samples

Prior to being tested, a set of five samples is conditioned in a circulating air oven for 7 days (168 h) at a uniform temperature of $70\text{ }^{\circ}\text{C} \pm 1\text{ }^{\circ}\text{C}$. Immediately afterwards, the samples are placed in a calcium chloride desiccator for at least 4 h to cool to room temperature. The other set of five samples is conditioned for 48 h at a uniform temperature of $23\text{ }^{\circ}\text{C} \pm 2\text{ }^{\circ}\text{C}$ and a relative humidity between 45 % and 55 %.

A.6.3 Mounting of samples

One sample is held with its longitudinal axis vertical by a clamp at its upper end so that its lower edge is 300 mm above a flat, horizontal layer of untreated surgical cotton 50 mm x 50 mm thinned out to a maximum free-standing thickness of 6 mm. An unlit Bunsen burner whose barrel has an inside diameter of $9,5\text{ mm} \pm 0,5\text{ mm}$ and a length of approximately 100 mm above the primary air inlet or inlets, is supported under the sample with the longitudinal axis of the barrel vertical and coincident with the longitudinal axis of the sample. The tip of the barrel is 9,5 mm below the sample. The burner support is arranged to enable the burner to be quickly removed from and precisely returned to its position under the sample. A gas supply of calorific value approximately 37 MJ/m^3 is used. While not in proximity to the sample, the burner is ignited and adjusted to produce a steady blue flame with an overall height of approximately 20 mm.

A.6.4 Test procedure

The burner flame is moved into position under the sample for 10 s, and then removed.

The duration t_1 of any flaming combustion of the sample after removal of the test flame is measured.

Immediately after flaming of the sample has ceased, the test is repeated on the same sample.

The duration t_2 of any flaming combustion of the sample after the second removal of the test flame, and the duration t_3 of any glowing combustion after the end of t_2 , are measured.

The above sequence of tests is repeated on the four remaining samples of each set.

A.6.5 Compliance criteria

The classification criteria for the material in the thickness tested are listed in table A.1.

Table A.1 – Materials classification

Criteria conditions	V-0	V-1	V-2
Afterflame time for each individual specimen, t_1 or t_2	≤10 s	≤30 s	≤30 s
Total afterflame time for any condition set, t_1 plus t_2 for the five specimens	≤50 s	≤250 s	≤250 s
Afterflame plus afterglow time for each individual specimen after the second flame application, t_2 plus t_3	≤30 s	≤60 s	≤60 s
Afterflame or afterglow of any specimen up to the holding clamp permitted?	No	No	No
Cotton indicator ignited by flaming particles or drops permitted?	No	No	Yes

A.6.6 Permitted retest

If only one sample of a set of five samples fails to comply with the relevant criteria in table A.1, another set of five samples, subjected to the same conditioning, is tested. All samples in this second set shall comply with the relevant criteria.

A.7 Flammability test for classifying foamed materials HF-1, HF-2 or HBF

P

A.7.1 Samples

Ten samples of a foamed plastic material intended to be classified as HF-1, HF-2 or HBF CLASS MATERIAL are tested as indicated below.

Material test samples are approximately 150 mm long by 50 mm wide, and of the smallest thickness used. For foam material which is normally attached to a panel of another material, it is permitted to use samples consisting of the foam material attached to a panel which is of the smallest thickness used.

A.7.2 Conditioning of samples

Prior to being tested, five samples (reference A) are conditioned in a circulating air oven for 7 days (168 h) at a uniform temperature of $70\text{ }^{\circ}\text{C} \pm 1\text{ }^{\circ}\text{C}$. Immediately afterwards, the samples are placed in a calcium chloride desiccator for at least 4 h to cool to room temperature. Five other samples (reference B) are conditioned for 48 h at a uniform temperature of $23\text{ }^{\circ}\text{C} \pm 2\text{ }^{\circ}\text{C}$ and a relative humidity between 45 % and 55 %.

A.7.3 Test procedure

Samples are supported on a horizontal wire screen (approximately 0,8 mm steel wire in 6,5 mm square mesh), 200 mm long by 75 mm wide, with 13 mm at one end turned up vertically. The screen is supported approximately 300 mm over a layer of surgical cotton.

A Bunsen burner with a fish-tail flame is used, its barrel having an inside diameter of $9,5\text{ mm} \pm 0,5\text{ mm}$, a length of approximately 100 mm above the primary air inlet or inlets and a flame spreader having a width of approximately 50 mm. It is supported 13 mm under the bend in the wire screen so that the flame is parallel to and central on the bend. The burner support is arranged to enable the burner to be quickly removed from and precisely returned to its position under the sample. A gas supply of calorific value approximately 37 MJ/m^3 is used. While not in proximity to the sample, the burner is ignited and adjusted to produce a steady blue test flame with an overall height of approximately 38 mm.

One sample is placed flat on the screen, one end being in contact with the upturned end of the screen. Samples of combined materials are placed with the foamed plastic side facing up.

The burner flame is moved into position under the sample for 60 s, and then removed. The test is then repeated on the other nine samples.

A.7.4 Compliance criteria

During and after the test the following conditions shall apply:

- not more than one sample of reference A and not more than one sample of reference B shall flame longer than 2 s after removal of the test flame;*
- no sample shall flame longer than 10 s after removal of the test flame;*
- no sample shall glow longer than 30 s after removal of the test flame;*
- no sample shall flame or glow for a distance greater than 60 mm from the end to which the test flame was applied.*

A.7.5 Compliance criteria, HF-2

The material is of CLASS HF-2 if it meets the conditions of A.7.4. For CLASS HF-2 ignition of the surgical cotton is permitted to occur.

A.7.6 Compliance criteria, HF-1

The material is of CLASS HF-1 if it meets the conditions of A.7.4 and additionally, the cotton is not ignited by any particles or drops released during or after application of the test flame.

A.7.7 Compliance criteria, HBF

The material is of CLASS HBF, if despite failing to meet the conditions of A.7.4, all specimens either:

- burn at a rate of under 40 mm/min over a 100 mm span; or*
- cease to burn before reaching 120 mm from the end to which the test flame is applied.*

A.7.8 Permitted retest, HF-1 or HF-2

A second set of five samples, subjected to the same conditioning, is tested if a set of five samples fails to comply with the requirements of A.7.5 or A.7.6 because of one of the following situations:

- one sample out of a set of five samples flames for more than 10 s and a second sample out of the same set flames for more than 2 s but less than 10 s as permitted by A.7.4; or*
- two samples out of a set of five samples flame for more than 2 s but less than 10 s; or*
- one sample out of a set of five samples flames or glows for a distance greater than 60 mm from the end to which the test flame was applied; or*
- one sample out of a set of five samples glows for longer than 30 s after removal of the test flame; or*
- for CLASS HF-1, the cotton is ignited by particles or drops released from one sample out of a set of five samples.*

A.7.9 Permitted retest, HBF

If only one sample from a set of five samples fails to comply with the requirements in A.7.7, a second set of five samples, subjected to the same conditioning, is tested. All samples from this second set of samples shall comply with the appropriate requirements in A.7.7 in order for the material of that thickness and density to be classified HBF CLASS MATERIAL.

A.8 Flammability test for classifying materials HB

P

A.8.1 Samples

Three samples of a material or assembly intended to be classified as HB CLASS MATERIAL are tested as indicated below.

Material test samples are approximately 130 mm long by 13 mm wide, with smooth edges, and of the smallest thickness used or less. For materials used in a thickness greater than 3 mm, the samples are reduced to 3 mm thick. The samples are marked across their width with lines at 25 mm and 100 mm from one end.

A.8.2 Conditioning of samples

Prior to being tested the samples are conditioned for 48 h at a uniform temperature of $23\text{ }^{\circ}\text{C} \pm 2\text{ }^{\circ}\text{C}$ and a relative humidity between 45 % and 55 %.

A.8.3 Mounting of samples

A sample is held by a clamp at the end farthest from the 25 mm mark, with its longitudinal axis horizontal and its transverse axis at 45° to the horizontal. A flat sheet of steel wire gauze (approximately 130 mm square and having eight openings per centimeter) is supported horizontally 10 mm below the lowest edge of the sample, and with the free end of the sample immediately above the edge of the gauze, see figure A.3.

An unlit Bunsen burner whose barrel has an inside diameter of $9,5\text{ mm} \pm 0,5\text{ mm}$ and a length of approximately 100 mm above the primary air inlet or inlets is supported with its longitudinal axis in the same vertical plane as the lowest edge of the sample, inclined at approximately 45° to the vertical, and with the lower edge of the barrel mouth 10 mm below the free end of the sample, so that the bottom edge of the sample is subjected to the test flame, when lit.

The burner support is arranged to enable the burner to be quickly removed from, and precisely returned to, its position under the sample. A gas supply of calorific value approximately 37 MJ/m^3 is used. When not in proximity to the sample, the burner is ignited and adjusted to produce a steady blue flame with an overall height of approximately 25 mm.

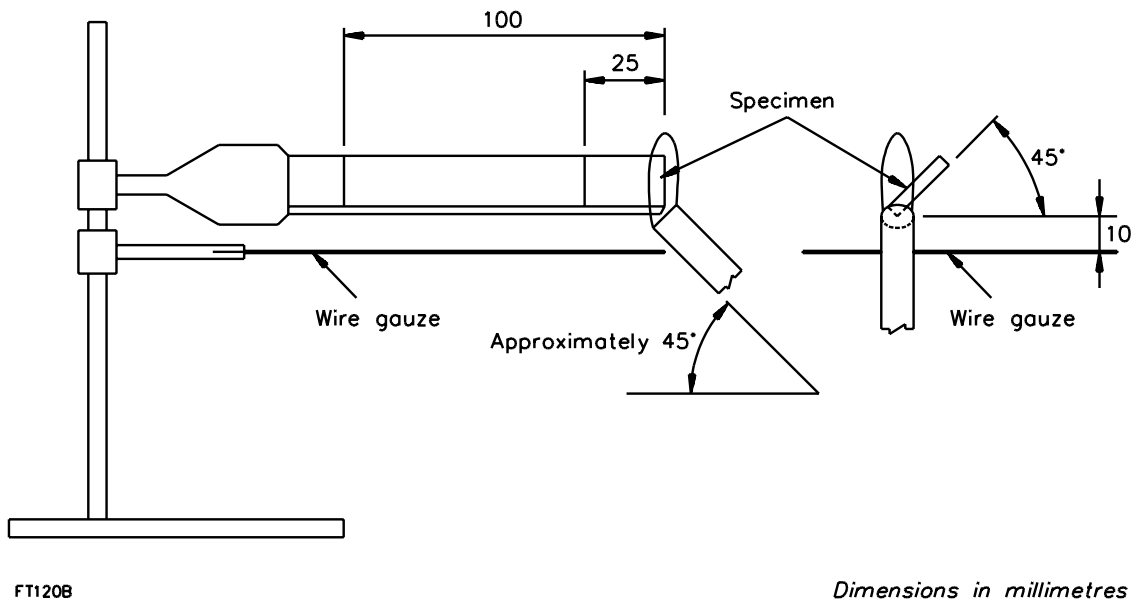

Figure A.3 – Test arrangement for flammability test for classifying materials HB

A.8.4 Test procedure

The burner flame is moved into position at the end of the sample for 30 s, or until burning reaches the 25 mm mark if this occurs earlier, and then removed. By timing the progress of flaming or glowing from the 25 mm mark to the 100 mm mark, at the lower edge of the sample, the rate of progress in millimetres per minute is calculated.

The test is repeated on the two remaining samples.

A.8.5 Compliance criteria

No sample shall:

- *have a calculated rate of flaming or glowing greater than:*
 - *40 mm/min for samples of a thickness of 3 mm; or*
 - *75 mm/min for samples of a thickness of less than 3 mm; or*
- *have flaming or glowing reach the 100 mm reference mark.*

A.8.6 Permitted retest

If only one sample of a set of three samples does not comply with A.8.5, another set of three samples is tested. All samples of this second set shall comply.

A.9 Flammability test for classifying materials 5V

P

A.9.1 Samples

For each of the tests, samples of the material intended to be classified as 5V CLASS MATERIAL are tested as indicated below.

The test is not applicable to samples of thickness greater than 13 mm and in such cases the tests of clause A.1 apply. If the classification is made as a result of testing samples of thickness less than 13 mm, it is applicable to any greater thickness up to a maximum of 13 mm.

Either ten samples of the material in the form of test bars (see A.9.4), or eight samples of the material in the form of test plaques (see A.9.5), are used. However, if bar specimens are observed to undergo shrinkage, elongation or melting, additional tests are conducted on test plaques.

A.9.2 Conditioning of samples

For each test, prior to being tested, one set of five test bars or four test plaques is conditioned for at least 48 h at a uniform temperature of $23\text{ °C} \pm 2\text{ °C}$ and a relative humidity of 45 % to 55 %. A further set of five test bars or four test plaques is conditioned in a circulating air oven for a duration of 7 days (168 h), at a uniform temperature 10 K greater than the maximum temperature of the material determined during the test of 4.5.1, or 70 °C, whichever is the higher, and then cooled in a calcium chloride desiccator for at least 4 h at room temperature.

A.9.3 Test flame

The test flame is obtained by means of a Bunsen burner whose barrel has an inside diameter of 9,5 mm ± 0,5 mm and a length of approximately 100 mm above the primary air inlet or inlets. A gas supply of calorific value approximately 37 MJ/m³ is used, and the test flame adjusted so that, while the burner is vertical, the overall height of the flame is approximately 130 mm and the height of the inner blue cone is approximately 40 mm.

A.9.4 Test procedure, test bars

When test bars are used, the two sets are tested. Each test bar is 130 mm long by 13 mm wide, and is the same thickness as the smallest thickness used in the equipment, but not greater than 13 mm.

Each test bar is supported from the upper end of the bar, with the longitudinal axis vertical, by a clamp on a ring stand. The burner is supported on an inclined plane of a mounting block so that the burner tube may be positioned at 20° from the vertical. The narrow edge of the bar faces the burner. A layer of untreated surgical cotton is located 300 mm below the point of application of the test flame.

The flame is applied to one of the lower corners of the bar at an angle of 20° from the vertical so that the tip of the blue cone touches the bar, see figure A.4.

The flame is applied for 5 s and removed for 5 s. The operation is repeated until each bar has been subjected to five applications of the test flame.

After the fifth removal of the test flame, the following are observed and recorded:

- duration of flaming plus glowing;*
- the distance the bar burned or was affected;*
- whether or not particles dripped from the bar during the test;*
- any deformation and change in physical strength immediately after burning and when cooled.*

The test results shall comply with the criteria in A.9.6, and there shall be no shrinkage, elongation or melting of any test bar. When shrinkage, elongation or melting is observed, the test of A.9.5 shall be conducted on test plaques.

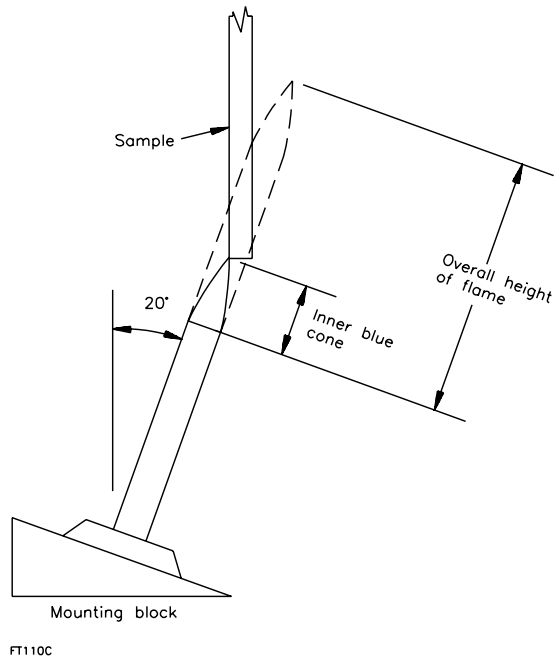

Figure A.4 – Vertical burning test for classifying materials 5V

A.9.5 Test procedure, test plaques

When test plaques are used, the two sets are tested. Each test plaque is 150 mm by 150 mm, and is of the same thickness as the minimum thickness used in the design of the equipment, but not greater than 13 mm.

Each set of four plaques is mounted and tested in a different position so that the test flame is applied as follows:

- A – one plaque of each set vertical with the flame applied to the lower corner of the plaque;
- B – one plaque of each set vertical with the flame applied to the lower edge of the plaque;
- C – one plaque of each set vertical with the flame applied to the center of one side of the plaque;
- D – one plaque of each set horizontal with the flame applied to the center of the bottom surface of the plaque.

A layer of untreated surgical cotton is located 300 mm below the point of the application of the test flame.

If the vertical position for the test plaque is involved, the test flame is applied at an angle of approximately 20° from the vertical.

For all positions, the tip of the blue cone is to be in contact with the test plaque. The test flame is applied for 5 s and removed for 5 s. This operation is repeated until the test plaque has been subjected to five applications of the test flame to the same location.

After the fifth removal of the test flame, the following are observed and recorded:

- duration of flaming plus glowing;*
- the distance the plaque burned or was affected;*
- whether or not particles dripped from the plaque during the test;*
- any deformation and change in physical strength immediately after burning and when cooled.*

The test results shall comply with the criteria in A.9.6, and the test results for positions C and D shall not show any significant destruction in the area of the test flame application.

A.9.6 Compliance criteria

During the test, the material shall not

- release flaming drops or particles capable of igniting the surgical cotton;*
- continue to burn with flaming or glowing combustion for more than 60 s after the fifth removal of the test flame;*
- be consumed completely.*

A.9.7 Permitted retest

If only one sample in any set fails to comply with A.9.6, the tests are repeated on a second set of samples subjected to the same conditioning. All of these samples shall comply.

A.10 Stress relief conditioning (see 4.2.7)

One sample consisting of the complete equipment, or of the complete ENCLOSURE together with any supporting framework, is placed in a circulating air oven at a temperature 10 K higher than the maximum temperature observed on the ENCLOSURE during the test of 4.5.1, but not less than 70 °C, for a period of 7 h, then permitted to cool to room temperature.

With the concurrence of the manufacturer, it is permitted to increase the above time duration.

For large equipment where it is impractical to condition a complete ENCLOSURE, it is permitted to use a portion of the ENCLOSURE representative of the complete assembly with regard to thickness and shape, including any mechanical support members

NOTE – Relative humidity need not be maintained at a specific value during this conditioning.

Annex B
(normative)

P

Motor tests under abnormal conditions
(see 4.7.2.2 and 5.3.2)

B.1 General requirements

Motors, other than d.c. motors in SECONDARY CIRCUITS, shall pass the tests of clauses B.4 and B.5 and, where applicable, clauses B.8, B.9 and B.10, except that the following motors are not required to pass the test of clause B.4

- motors which are used for air-handling only and where the air propelling component is directly coupled to the motor shaft; and*
- shaded pole motors whose values of locked-rotor current and no-load current do not differ by more than 1 A and have a ratio of not more than 2/1.*

DC motors in SECONDARY CIRCUITS shall pass the tests of clauses B.6, B.7 and B.10 except that motors which by their intrinsic operation normally operate under locked-rotor conditions, such as stepper motors, are not tested.

B.2 Test conditions

Unless otherwise specified in this annex, during the test the equipment is operated at RATED VOLTAGE, or at the upper voltage of the RATED VOLTAGE RANGE.

The tests are carried out either in the equipment or under simulated conditions on the bench. It is permitted to use separate samples for bench tests. Simulated conditions include:

- any protection devices which would protect the motor in the complete equipment; and*
- use of any mounting means which may serve as a heat sink to the motor frame.*

Temperatures of windings are measured as specified in 1.4.13. Where thermocouples are used they are applied to the surface of the motor windings. Temperatures are determined at the end of the test period where specified, otherwise when the temperature has stabilized, or at the instant of operation of fuses, THERMAL CUT-OUTS, motor protection devices and the like.

For totally enclosed, impedance-protected motors, the temperatures are measured by thermocouples applied to the motor case.

When motors without inherent thermal protection are tested under simulated conditions on the bench, the measured winding temperature is adjusted to take into account the ambient temperature in which the motor is normally located within the equipment as measured during the test of 4.5.1.

B.3 Maximum temperatures

For the tests in clauses B.5, B.7, B.8 and B.9 the temperature limits, as specified in table B.1, shall not be exceeded for each class of insulating material.

Table B.1
Permitted temperature limits for motor windings (except for running overload test)

Maximum temperature °C					
Method of protection	Class A	Class E	Class B	Class F	Class H
Protection by inherent or external impedance	150	165	175	190	210
Protection by protective device which operates during the first hour	200	215	225	240	260
Protection by any protective device:					
– maximum after first hour	175	190	200	215	235
– arithmetic average during the 2nd hour and during the 72nd hour	150	165	175	190	210

The arithmetic average temperature is determined as follows:

The graph of temperature against time, see figure B.1, while the power to the motor is cycling on and off, is plotted for the period of test under consideration. The arithmetic average temperature (t_A) is determined by the formula:

$$t_A = \frac{t_{\max} + t_{\min}}{2}$$

where:

t_{\max} is the average of the maxima;

t_{\min} is the average of the minima.

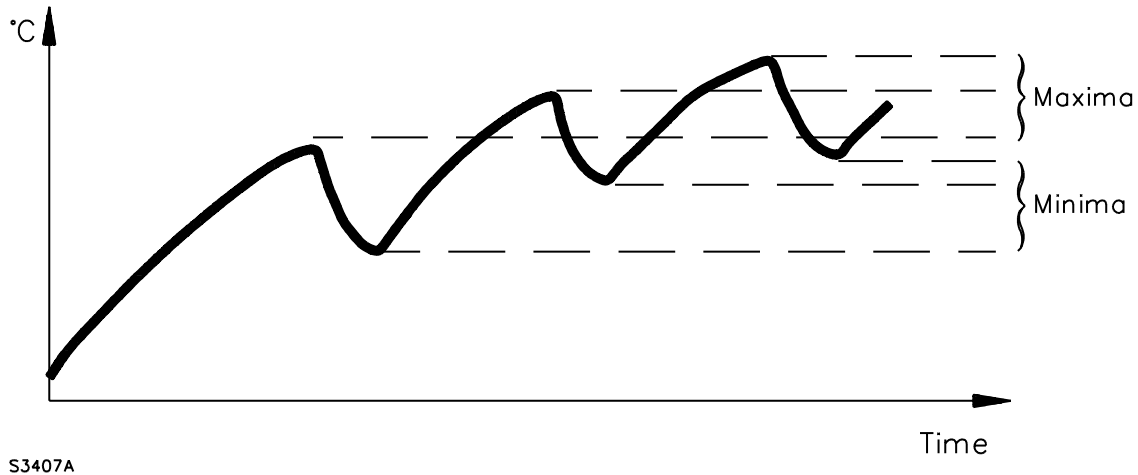

Figure B.1 – Determination of arithmetic average temperature

For the tests in clauses B.4 and B.6 the temperature limits, as specified in table B.2, shall not be exceeded for each class of insulating material.

Table B.2
Permitted temperature limits for running overload tests

Maximum temperature °C				
Class A	Class E	Class B	Class F	Class H
140	155	165	180	200

B.4 Running overload test

A running overload protection test is carried out by operating the motor under NORMAL LOAD. The load is then increased so that the current is increased in appropriate gradual steps, the motor supply voltage being maintained at its original value. When steady conditions are established, the load is again increased. The load is thus progressively increased in appropriate steps but without reaching locked-rotor condition (see B.5), until the overload protection device operates.

The motor winding temperatures are determined during each steady period and the maximum temperature recorded shall not exceed the values specified in table B.2.

B.5 Locked-rotor overload test

A locked-rotor test is carried out starting at room temperature.

The duration of the test is as follows:

- a motor protected by inherent or external impedance is operated with its rotor locked for 15 days except that testing may be discontinued when the windings of the motor, of either the open or totally enclosed type, reach a constant temperature, provided that the constant temperature is not more than that specified in 4.5.1 for the insulation system used;*
- a motor with an automatic reset protection device is cycled with its rotor locked for 18 days;*
- a motor with a manual reset protection device is cycled with its rotor locked for 60 cycles, the protection device being reset after each operation as soon as possible for it to remain closed, but after not less than 30 s;*
- a motor with a non-resettable protection device is operated with its rotor locked until the device operates.*

Temperatures are recorded at regular intervals during the first three days for a motor with inherent or external impedance protection or with an automatic reset protection device, or during the first ten cycles for a motor with a manual reset protection device, or at the time of operation of a non-resettable protection device.

The temperatures shall not exceed the values specified in table B.1.

During the test, protection devices shall operate reliably without breakdown of insulation to the motor frame or permanent damage to the motor, including excessive deterioration of the insulation.

Permanent damage to the motor includes:

- severe or prolonged smoking or flaming;*
- electrical or mechanical breakdown of any associated component part such as a capacitor or starting relay;*
- flaking, embrittlement or charring of insulation.*

Discoloration of the insulation is permitted but charring or embrittlement to the extent that insulation flakes off or material is removed when the winding is rubbed with the thumb is not permitted.

After the period specified for temperature measurement, the motor shall withstand the electric strength test in 5.2.2 after the insulation has cooled to room temperature and with test voltages reduced to 0,6 times the specified values. No further electric strength test is required.

NOTE – Continuation of the test of an automatic reset protection device beyond 72 h, and of a manual reset protection device beyond 10 cycles, is for the purpose of demonstrating the capability of the device to make and break locked-rotor current for an extended period of time.

B.6 Running overload test for d.c. motors in secondary circuits

The running overload test is carried out only if a possibility of an overload occurring is determined by inspection or by review of the design. The test need not be carried out, for example, where electronic drive circuits maintain a substantially constant drive current.

The test is carried out by operating the motor under NORMAL LOAD. The load is then increased so that the current is increased in appropriate gradual steps, the motor supply voltage being maintained at its original value. When steady conditions are established the load is again increased. The load is thus progressively increased in appropriate steps until either the overload protection device operates or the winding becomes an open circuit.

The motor winding temperatures are determined during each steady period and the maximum temperature recorded shall not exceed the value in table B.2, except that, where difficulty is experienced in obtaining accurate temperature measurements, due to the small size or unconventional design of the motor, it is permitted to use the following test instead of temperature measurement.

During the running overload test, the motor is covered with a single layer of bleached cotton cheesecloth of approximately 40 g/m². There shall be no ignition of the cheesecloth during the test or at its conclusion.

Compliance with either method is acceptable; it is not necessary to comply with both methods.

B.7 Locked-rotor overload test for d.c. motors in secondary circuits

Motors shall pass the test in B.7.1, except that, where difficulty is experienced in obtaining accurate temperature measurements, due to the small size or unconventional design of the motor, the method of B.7.2 can be used instead. Compliance may be established by either method.

B.7.1 Test procedure

The motor is operated at the voltage used in its application and with its rotor locked for 7 h or until steady conditions are established, whichever is the longer. Temperatures shall not exceed the values specified in table B.1.

B.7.2 Alternative test procedure

The motor is placed on a wooden board which is covered with a single layer of wrapping tissue, and the motor in turn covered with a single layer of bleached cotton cheesecloth of approximately 40 g/m².

NOTE – Wrapping tissue is defined in ISO 4046 as a soft and strong, lightweight wrapping paper of grammage generally between 12 g/m² and 30 g/m², primarily intended for protective packaging of delicate articles and for gift wrapping.

The motor is then operated at the voltage used in its application and with its rotor locked for 7 h or until steady conditions are established, whichever is the longer.

At the conclusion of the test there shall be no ignition of the wrapping tissue or cheesecloth.

B.7.3 Electric strength test

Following the test of B.7.1 or B.7.2, as applicable, if the motor voltage exceeds 42,4 V peak, or 60 V d.c., and after it has cooled to room temperature, the motor shall withstand the electric strength test in 5.2.2 but with test voltages reduced to 0,6 times the specified values.

B.8 Test for motors with capacitors

Motors having phase-shifting capacitors are tested under locked rotor conditions with the capacitor short-circuited or open-circuited (whichever is the more unfavourable).

The short-circuit test is not made if the capacitor is so designed that, upon failure, it will not remain short-circuited.

Temperatures shall not exceed the values specified in table B.1.

NOTE – Locked rotor is specified because some motors may not start and variable results could be obtained.

B.9 Test for three-phase motors

Three-phase motors are tested under NORMAL LOAD, with one line conductor disconnected, unless circuit controls prevent the application of voltage to the motor with one or more supply conductors disconnected.

The effect of other loads and circuits within the equipment may necessitate that the motor be tested within the equipment and with each of the three line conductors disconnected one at a time.

Temperatures shall not exceed the values specified in table B.1.

B.10 Test for series motors

Series motors are operated at a voltage equal to 1,3 times the motor voltage rating for 1 min with the lowest possible load.

After the test, windings and connections shall not have worked loose and no hazard shall be present in the meaning of this standard.

Annex C
(normative)
Transformers
(see 1.5.4 and 5.3.3)

C.1 Overload test

If the tests in this clause are carried out under simulated conditions on the bench, these conditions shall include any protection device which would protect the transformer in the complete equipment.

Transformers for switch mode power supply units are tested in the complete power supply unit or in the complete equipment. Test loads are applied to the output of the power supply unit.

A linear transformer or a ferro-resonant transformer has each secondary winding loaded in turn, with any other secondaries loaded between zero and their specified maxima to result in the maximum heating effect.

The output of a switch mode power supply is loaded to result in the maximum heating effect in the transformer.

NOTE – For examples of loading to give the maximum heating effect, see annex X.

Where an overload cannot occur or is unlikely to create a hazard, the above tests are not made.

Maximum temperatures of windings shall not exceed the values in table C.1 when measured as specified in 1.4.13, and determined as specified below:

- with external overcurrent protection: at the moment of operation, for determination of the time until the overcurrent protection operates, it is permitted to refer to a data sheet of the overcurrent protection device showing the trip time versus the current characteristics;*
- with an AUTOMATIC RESET THERMAL CUT-OUT: as shown in table C.1 and after 400 h;*
- with a MANUAL RESET THERMAL CUT-OUT: at the moment of operation;*
- for current-limiting transformers: after temperature has stabilized.*

Secondary windings which exceed the temperature limits but which become open circuit or otherwise require replacement of the transformer do not constitute a failure of this test, provided that no hazard is created in the meaning of this standard.

Table C.1
Permitted temperature limits for transformer windings

Maximum temperature °C					
Protection method	Class A	Class E	Class B	Class F	Class H
Protection by inherent or external impedance	150	165	175	190	210
Protection by protective device which operates during the first hour	200	215	225	240	260
Protection by any protective device:					
– maximum after first hour	175	190	200	215	235
– arithmetic average during the 2nd hour and during the 72nd hour	150	165	175	190	210

The arithmetic average temperature is determined as follows:

The graph of temperature against time, (see figure C.1), while the power to the transformer is cycling on and off, is plotted for the period of test under consideration. The arithmetic average temperature (t_A) is determined by the formula:

$$t_A = \frac{t_{\max} + t_{\min}}{2}$$

where:

t_{\max} is the average of the maxima;

t_{\min} is the average of the minima.

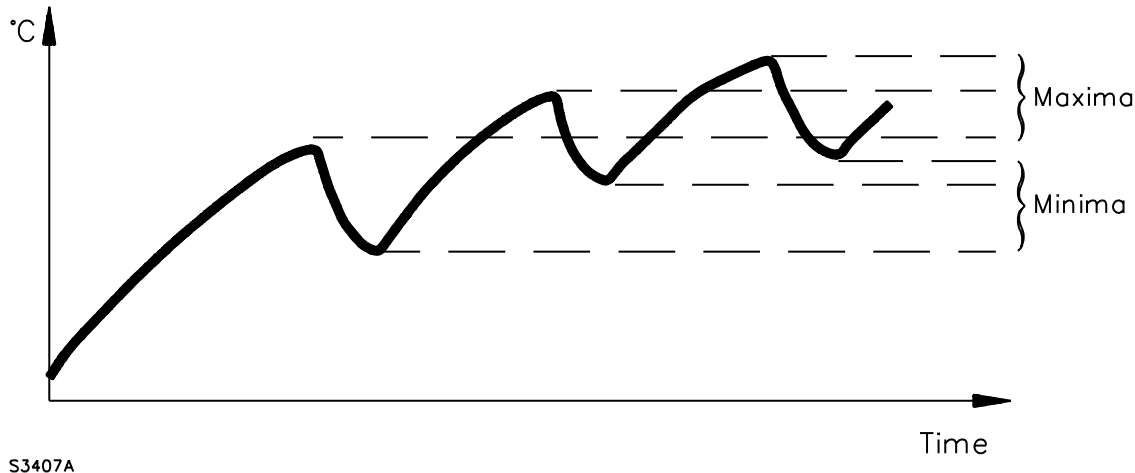

Figure C.1 – Determination of arithmetic average temperature

C.2 Insulation

Insulation in transformers shall comply with the following requirements.

Windings and conductive parts of transformers shall be treated as parts of the circuits to which they are connected, if any. The insulation between them shall comply with the relevant requirements of 2.10 and pass the relevant tests of 5.2.2, according to the application of the insulation in the equipment (see 2.9.5).

Precautions shall be taken to prevent the reduction below the required minimum values of CLEARANCES and CREEPAGE DISTANCE that provide BASIC, SUPPLEMENTARY OR REINFORCED INSULATION by:

- displacement of windings or their turns;*
- displacement of internal wiring or wires for external connections;*
- undue displacement of parts of windings or internal wiring, in the event of rupture of wires adjacent to connections or loosening of the connections;*
- bridging of insulation by wires, screws, washers and the like should they loosen or become free.*

It is not expected that two independent fixings will loosen at the same time.

All windings shall have the end turns retained by positive means.

Compliance is checked by inspection, measurement, and if necessary, by the following tests.

If a transformer is fitted with an earthed screen for protective purposes, the transformer shall pass the test of 2.6.3.3 between the earthed screen and the earthing terminal of the transformer.

No electric strength test applies to insulation between any winding and the core or screen, provided that the core or screen is totally enclosed or encapsulated and there is no electrical connection to the core or screen. However, the tests between windings which have terminations continue to apply.

NOTE – Examples of acceptable forms of construction are the following (there are other acceptable forms of construction):

- windings isolated from each other by placing them on separate limbs of the core, with or without spools;
- windings on a single spool, with a partition wall, where either the spool and partition wall are pressed or moulded in one piece, or a pushed-on partition wall has an intermediate sheath or covering over the joint between the spool and the partition wall;
- concentric windings on a spool of insulating material without flanges, or on insulation applied in thin sheet form to the transformer core;
- insulation is provided between windings consisting of sheet insulation extending beyond the end turns of each layer;
- concentric windings, separated by an earthed conductive screen which consists of metal foil extending the full width of the windings, with suitable insulation between each winding and the screen. The conductive screen and its lead-out wire have a cross section sufficient to ensure that on breakdown of the insulation an overload device will open the circuit before the screen is destroyed. The overload device may be a part of the transformer.

Annex D
(normative)
Measuring instruments for touch-current tests
(see 5.1.4)

D.1 Measuring instrument

The measuring instrument of figure D.1 is from IEC 60990, figure 4.

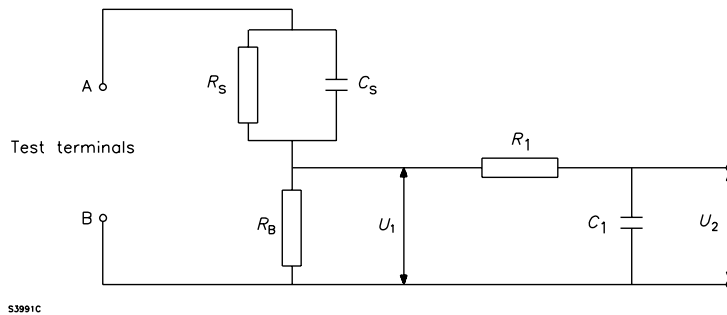

R_S	1 500 Ω	
R_B	500 Ω	
R_1	10 k Ω	
C_S	0,22 μ F	
C_1	0,022 μ F	
Voltmeter or oscilloscope (r.m.s. or peak reading)	Input resistance:	>1 M Ω
	Input capacitance:	<200 pF
	Frequency range:	15 Hz up to 1 MHz
		(appropriate for the highest frequency of interest, see 1.4.7)

Figure D.1 – Measuring instrument

The measuring instrument is calibrated by comparing the frequency factor of U_2 with the solid line in figure F.2 of IEC 60990 at various frequencies. A calibration curve is constructed showing the deviation of U_2 from the ideal curve as a function of frequency.

D.2 Alternative measuring instrument

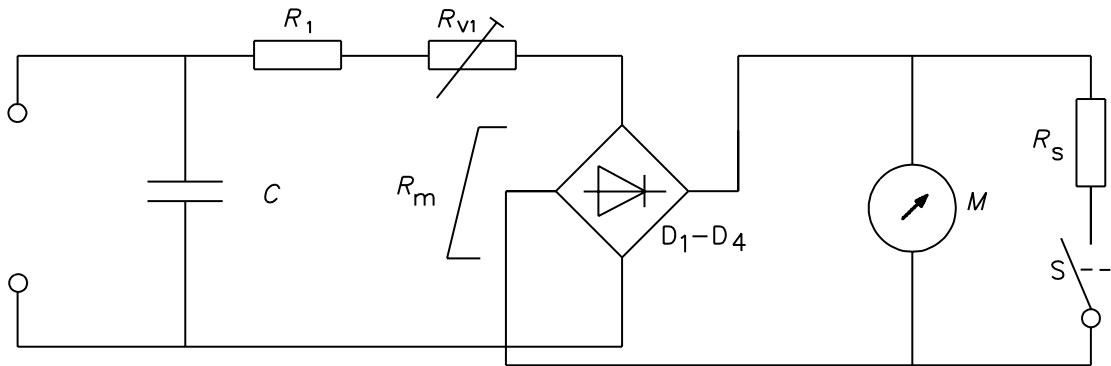

S3408A

M	0 mA – 1 mA moving coil movement
$R_1 + R_{V1} + R_m$ at 0,5 mA d.c. =	1 500 $\Omega \pm 1\%$ with $C = 150 \text{ nF} \pm 1\%$ or 2 000 $\Omega \pm 1\%$ with $C = 112 \text{ nF} \pm 1\%$
D1 – D4	Rectifier
R_S	Non-inductive shunt for $\times 10$ range
S	Sensitivity button (press for maximum sensitivity)

Figure D.2 – Alternative measuring instrument

The instrument comprises a rectifier/moving coil meter with additional series resistance, the two being shunted by a capacitor, as shown in figure D.2. The effect of the capacitor is to reduce the sensitivity to harmonics and other frequencies above the power frequency. The instrument should also include a $\times 10$ range obtained by shunting the meter coil by a non-inductive resistor. It is also permitted to include overcurrent protection, provided that the method used does not affect the basic characteristics of the instrument.

R_{V1} is adjusted for the desired value of total resistance at 0,5 mA d.c.

The meter is calibrated at the following calibration points on the maximum sensitivity range at 50 Hz to 60 Hz sinusoidal:

0,25 mA, 0,5 mA, 0,75 mA.

The following response is checked at the 0,5 mA calibration point:

Sensitivity at 5 kHz sinusoidal: 3,6 mA $\pm 5\%$.

Annex E
(normative)
Temperature rise of a winding
(see 1.4.13 and 4.5.1)

The value of the temperature rise of a winding is calculated from the formula:

for a copper winding
$$\Delta t = \frac{R_2 - R_1}{R_1} (234.5 + t_1) - (t_2 - t_1)$$

for an aluminum winding
$$\Delta t = \frac{R_2 - R_1}{R_1} (225 + t_1) - (t_2 - t_1)$$

where

Δt is the temperature rise, in kelvins;

R_1 is the resistance of the winding at the beginning of the test, in ohms;

R_2 is the resistance of the winding at the end of the test, in ohms;

t_1 is the room temperature at the beginning of the test, in degrees Celsius;

t_2 is the room temperature at the end of the test, in degrees Celsius.

At the beginning of the test, the windings are at room temperature.

It is recommended that the resistance of windings at the end of the test be determined by taking resistance measurements as soon as possible after switching off, and then at short intervals so that a curve of resistance against time can be plotted for ascertaining the resistance at the instant of switching off.

Annex F
(normative)
Measurement of clearances and creepage distances
(see 2.10)

The methods of measuring CLEARANCES and CREEPAGE DISTANCES which are specified in the following figures are used in interpreting the requirements of this standard.

In the following figures, the value of X is given in table F.1. Where the distance shown is less than X, the depth of the gap or groove is disregarded when measuring a CREEPAGE DISTANCE.

Table F.1 is valid only if the required minimum CLEARANCE is 3 mm or more. If the required minimum CLEARANCE is less than 3 mm, the value of X is the lesser of:

- the relevant value in Table F.1; or
- one third of the required minimum CLEARANCE.

Table F.1
Value of X

Pollution degree (see 2.10.1)	X mm
1	0,25
2	1,0
3	1,5

In the following figures, CLEARANCES and CREEPAGE DISTANCES are shown as follows:

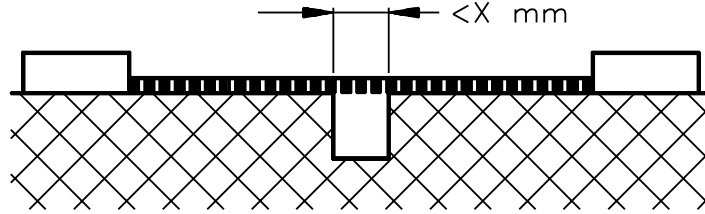

Condition: Path under consideration includes a parallel or converging-sided groove of any depth with width less than X mm.

Rule: CLEARANCE and CREEPAGE DISTANCE are measured directly across the groove.

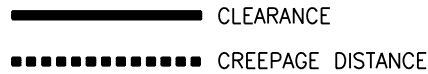

S4146A

Figure F.1 – Narrow groove

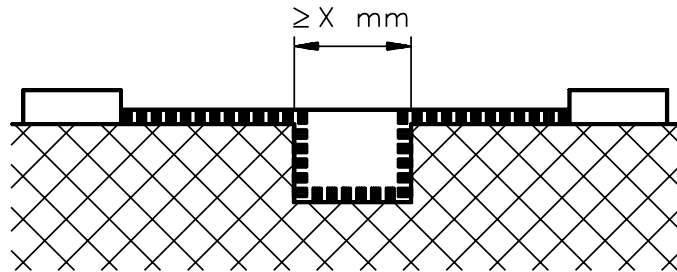

Condition: Path under consideration includes a parallel-sided groove of any depth, and equal to or more than X mm wide.

Rule: CLEARANCE is the "line of sight" distance. CREEPAGE DISTANCE path follows the contour of the groove.

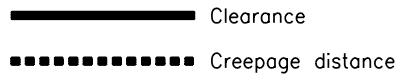

S4147A

Figure F.2 – Wide groove

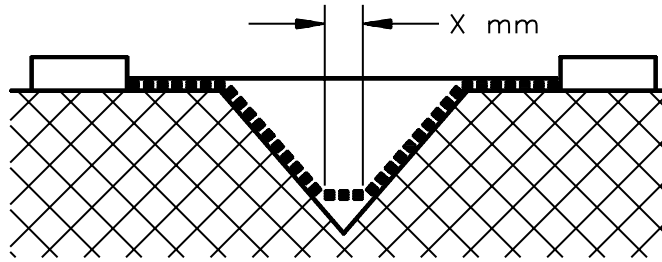

Condition: Path under consideration includes a V-shaped groove with internal angle of less than 80° and a width greater than X mm.

Rule: CLEARANCE is "line of sight" distance. CREEPAGE DISTANCE path follows the contour of the groove but "short circuits" the bottom of the groove by a link X mm long.

————— Clearance
 - - - - - Creepage distance

S4148A

Figure F.3 – V-shaped groove

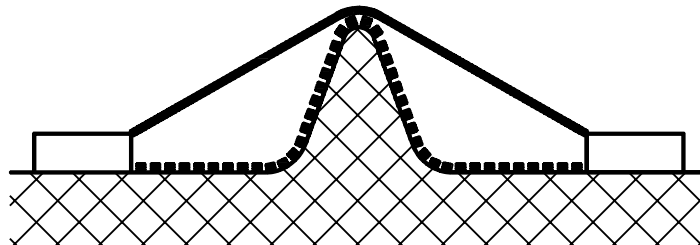

Condition: Path under consideration includes a rib.

Rule: CLEARANCE is the shortest direct air path over the top of the rib. CREEPAGE DISTANCE path follows the contour of the rib.

————— Clearance
 - - - - - Creepage distance

S4149A

Figure F.4 – Rib

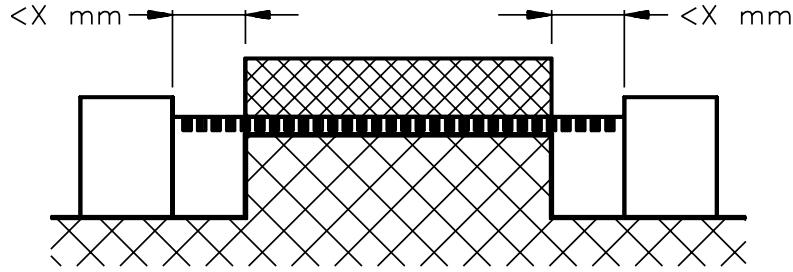

Condition: Path under consideration includes an uncemented joint with grooves less than X mm wide on either side.

Rule: CLEARANCE and CREEPAGE DISTANCE path is the "line of sight" distance shown.

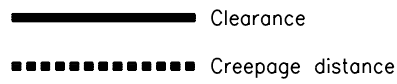

S4150A

Figure F.5 – Uncemented joint with narrow groove

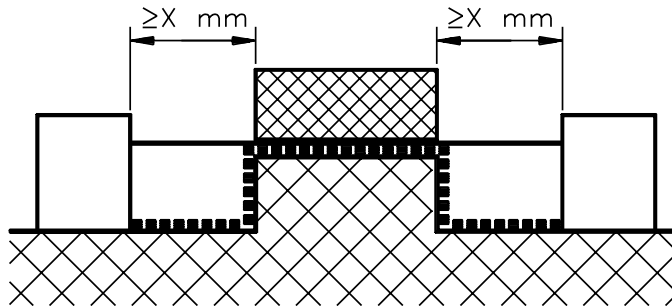

Condition: Path under consideration includes an uncemented joint with a groove equal to or more than X mm wide each side.

Rule: CLEARANCE is the "line of sight" distance. CREEPAGE DISTANCE path follows the contour of the groove.

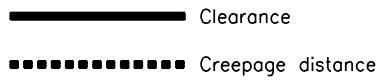

S4151A

Figure F.6 – Uncemented joint with wide groove

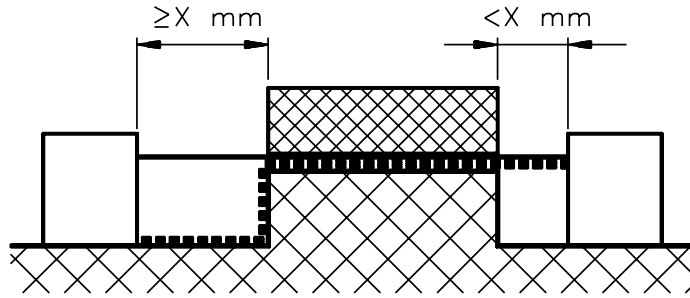

Condition: Path under consideration includes an uncemented joint with a groove on one side less than X mm wide and a groove on the other equal to or more than X mm wide.

Rule: CLEARANCE and CREEPAGE DISTANCE path are as shown.

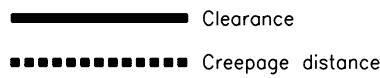

S4152A

Figure F.7 – Uncemented joint with narrow and wide grooves

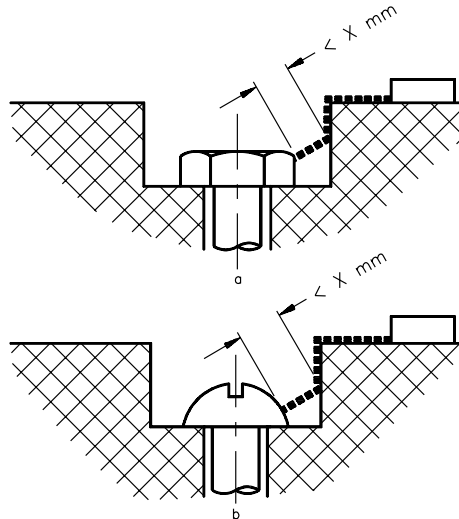

Gap between head of screw and wall of recess too narrow to be taken into account.

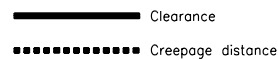

S4153A

Figure F.8 – Narrow recess

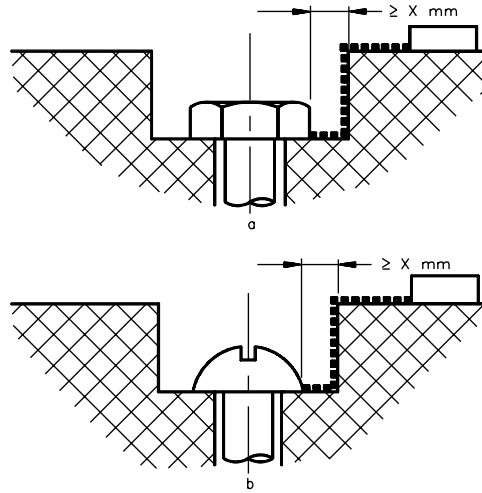

Gap between head of screw and wall of recess wide enough to be taken into account.

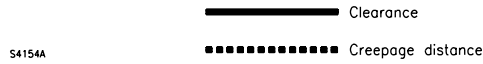

Figure F.9 – Wide recess

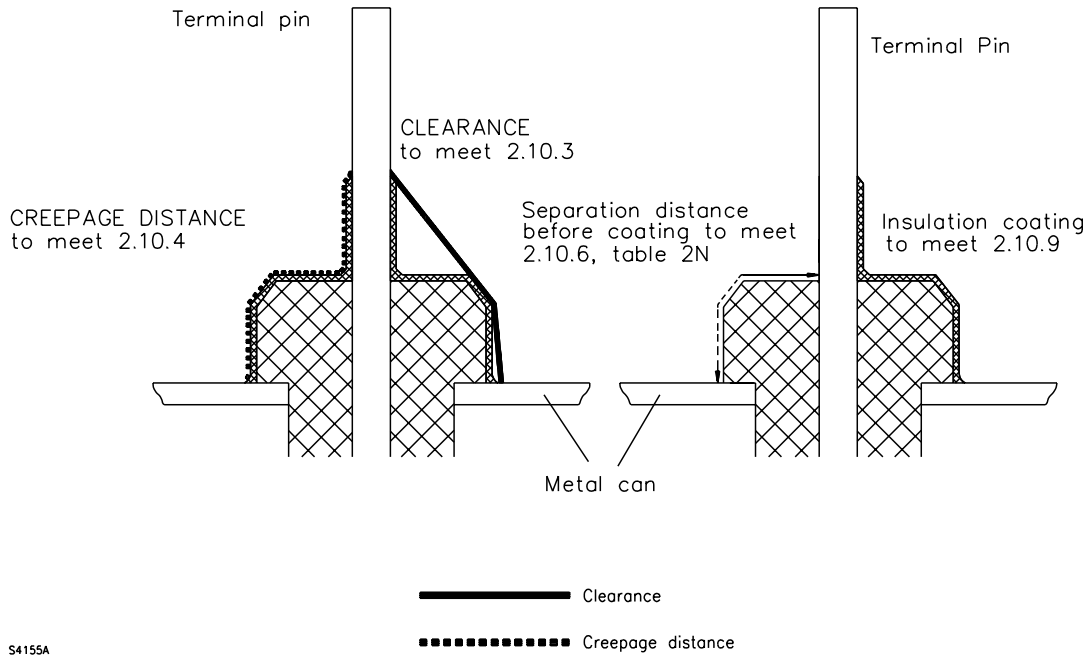
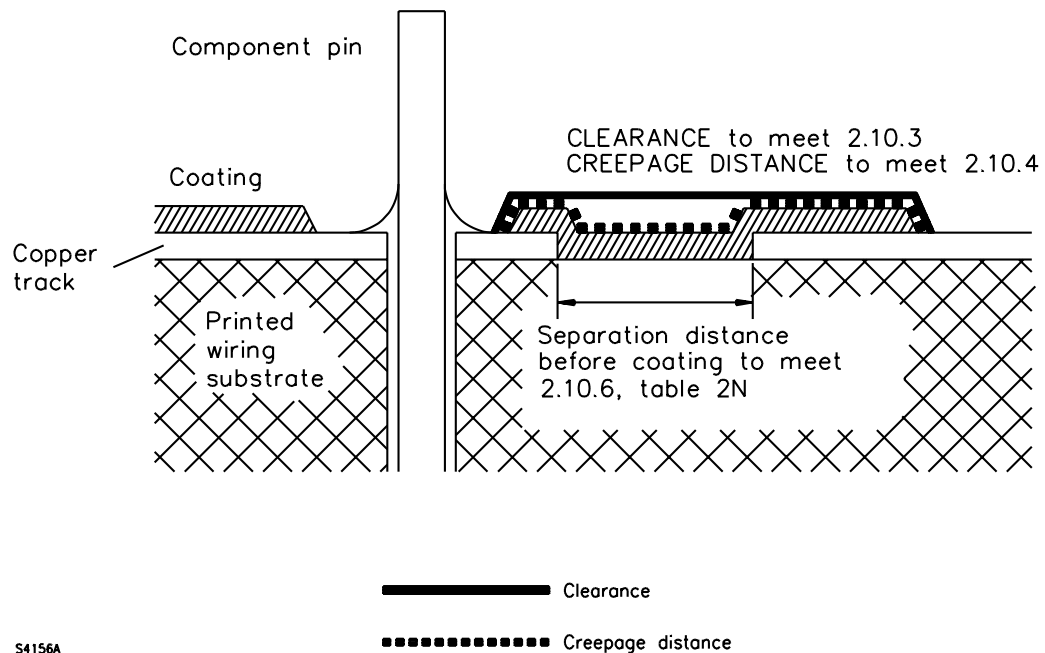
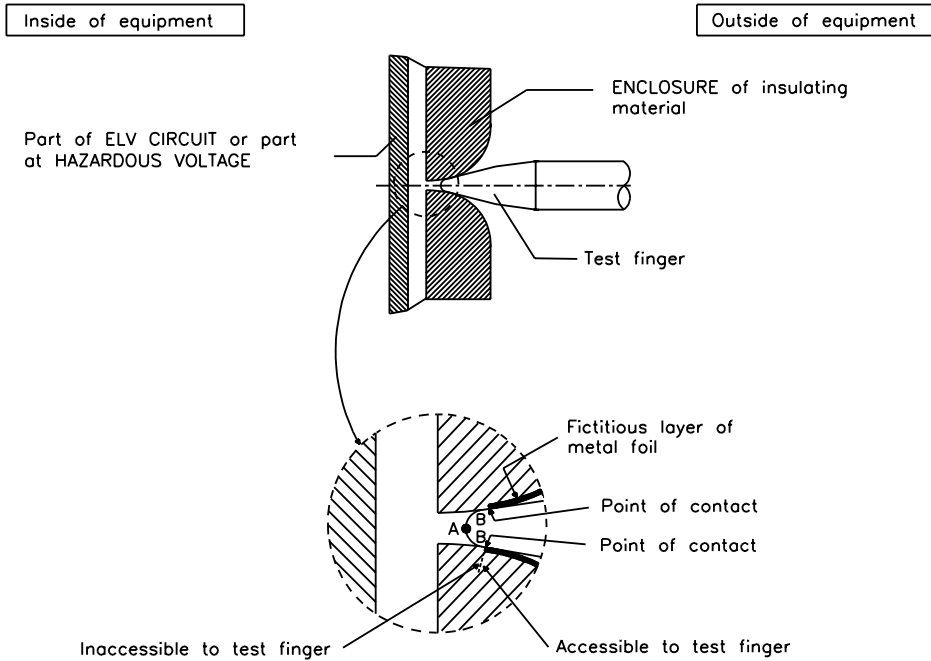

Figure F.10 – Coating around terminals



S4156A

Figure F.11 – Coating over printed wiring



Point A is used for determining the air gap to a part at a voltage exceeding 1 000 V a.c. or 1 500 V d.c. (see 2.1.1.1).

Point B is used for measurements of CLEARANCE and CREEPAGE DISTANCE from the outside of an ENCLOSURE of insulating material to a part inside the ENCLOSURE (see 2.10.3.1 and 2.10.4).

SM970D

Figure F.12 – Example of measurements in an enclosure of insulating material

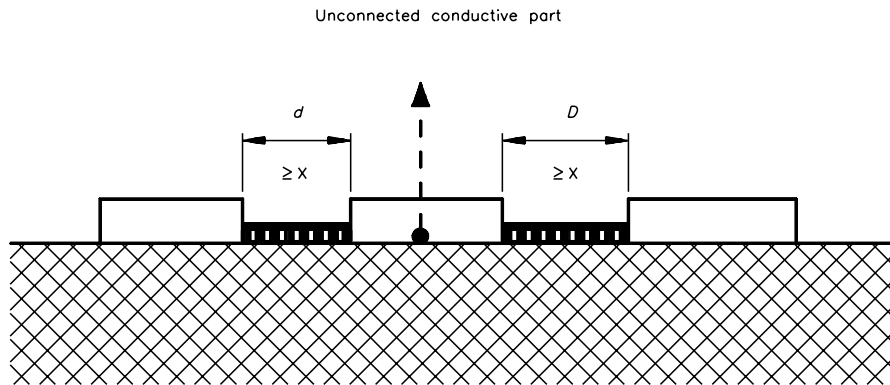

Condition: Insulation distance with intervening, unconnected conductive part.

Rule: CLEARANCE is the distance $d + D$.
CREEPAGE DISTANCE is also $d + D$.
Where the value of d or D is smaller than X , it shall be considered as zero.

————— Clearance
●●●●●●●● Creepage distance

54157A

Figure F.13 – Intervening, unconnected conductive part

Annex G
(normative)
Alternative method for determining minimum clearances

This annex contains the alternative method for determining minimum CLEARANCES referred to in 2.10.3.

There is no electric strength test to verify CLEARANCES.

G.1 Summary of the procedure for determining minimum clearances

NOTE – The minimum clearances for FUNCTIONAL, BASIC, SUPPLEMENTARY and REINFORCED INSULATION, whether in a PRIMARY CIRCUIT OR another circuit, depend on the REQUIRED WITHSTAND VOLTAGE. The REQUIRED WITHSTAND VOLTAGE depends in turn on the combined effect of the normal operating voltage (including repetitive peaks due to internal circuitry such as switch mode power supplies) and non-repetitive overvoltages due to external transients.

To determine the minimum value for each required CLEARANCE, the following steps shall be used:

1. Measure the PEAK WORKING VOLTAGE across the CLEARANCE in question.
2. If the equipment is mains operated:
 - determine the MAINS TRANSIENT VOLTAGE (G.2); and
 - calculate the peak value of the nominal AC MAINS SUPPLY voltage.
3. Use the rules in G.4 a) and the above voltage values to determine the REQUIRED WITHSTAND VOLTAGE for AC MAINS SUPPLY transients and internal transients. In the absence of transients coming from a TELECOMMUNICATION NETWORK, go to step 7.
4. If the equipment is to be connected to a TELECOMMUNICATION NETWORK, determine the TELECOMMUNICATION NETWORK TRANSIENT VOLTAGE (G.3).
5. Use the TELECOMMUNICATION NETWORK TRANSIENT VOLTAGE and the rules in G.4 b) to determine the REQUIRED WITHSTAND VOLTAGE for TELECOMMUNICATION NETWORK transients. In the absence of mains and internal transients, go to step 7.
6. Use the rules in G.4 c) to determine the total REQUIRED WITHSTAND VOLTAGE.
7. Use the REQUIRED WITHSTAND VOLTAGE to determine the minimum CLEARANCE (G.6).

G.2 Determination of mains transient voltage

For equipment to be supplied from the AC MAINS SUPPLY, the value of the MAINS TRANSIENT VOLTAGE depends on the Overvoltage Category and the nominal value of the AC MAINS SUPPLY voltage. In general, CLEARANCES in equipment intended to be connected to the AC MAINS SUPPLY shall be designed for a MAINS TRANSIENT VOLTAGE in Overvoltage Category II.

Equipment that is part of the building power installation, or that may be subject to transient overvoltages exceeding those for Overvoltage Category II, shall be designed for Overvoltage Category III or IV, unless additional protection is to be provided external to the equipment. In this case, the installation instructions shall state the need for such external protection.

It should be noted that annex G only provides a method of determining minimum CLEARANCES for Overvoltage Categories III and IV. Other aspects of design must be considered, for example requirements for solid insulation and for electric strength testing (for which see IEC 60664-1) and appropriate rating of components to withstand the MAINS TRANSIENT VOLTAGES given in table G.1.

The applicable value of the MAINS TRANSIENT VOLTAGE shall be determined from the overvoltage category and the nominal AC MAINS SUPPLY voltage using table G.1.

Table G.1 – Mains transient voltages

Nominal AC MAINS SUPPLY voltage line-to-neutral up to and including V r.m.s.	MAINS TRANSIENT VOLTAGE			
	V _{peak}			
	Overvoltage Category			
	I	II	III	IV
50	330	500	800	1 500
100	500	800	1 500	2 500
150 ¹⁾	800	1 500	2 500	4 000
300 ²⁾	1 500	2 500	4 000	6 000
600 ³⁾	2 500	4 000	6 000	8 000
1) Including 120/208 or 120/240 V. 2) Including 230/400 or 277/480 V. 3) Including 400/690 V.				

NOTE – In Norway, due to the IT power distribution system used, the AC MAINS SUPPLY voltage is considered to be equal to the line-to-line voltage, and will remain 230 V in case of a single earth fault.

G.3 Determination of telecommunication network transient voltage

If the TELECOMMUNICATION NETWORK TRANSIENT VOLTAGE is not known for the TELECOMMUNICATION NETWORK in question, it shall be taken as:

- 1 500 V_{peak} if the circuit connected to the TELECOMMUNICATION NETWORK is a TNV-1 CIRCUIT or a TNV-3 CIRCUIT; and
- 800 V_{peak} if the circuit connected to the TELECOMMUNICATION NETWORK is an SELV CIRCUIT or a TNV-2 CIRCUIT.

G.4 Determination of required withstand voltage

a) Mains and internal transients

- PRIMARY CIRCUIT receiving the unattenuated mains transient:

In such a PRIMARY CIRCUIT, the effect of transients coming from a TELECOMMUNICATION NETWORK is ignored, and the following rules shall be applied:

Rule 1) If the PEAK WORKING VOLTAGE, U_{pw} , is less than the peak value of the nominal AC MAINS SUPPLY voltage, the REQUIRED WITHSTAND VOLTAGE is the MAINS TRANSIENT VOLTAGE determined in G.2;

$$U_{\text{required withstand}} = U_{\text{mains transient}}$$

Rule 2) If the PEAK WORKING VOLTAGE, U_{pw} , is greater than the peak value of the nominal AC MAINS SUPPLY voltage, the REQUIRED WITHSTAND VOLTAGE is the MAINS TRANSIENT VOLTAGE determined in G.2, plus the difference between the PEAK WORKING VOLTAGE and the peak value of the nominal AC MAINS SUPPLY voltage.

$$U_{\text{required withstand}} = U_{\text{mains transient}} + U_{pw} - U_{\text{mains peak}}$$

- SECONDARY CIRCUIT whose PRIMARY CIRCUIT receives the unattenuated mains transient:

In such a SECONDARY CIRCUIT, the REQUIRED WITHSTAND VOLTAGE shall be determined as follows, ignoring the effect of transients coming from TELECOMMUNICATION NETWORKS.

The above rules 1) and 2) are applied, with the MAINS TRANSIENT VOLTAGE determined in G.2 replaced by a voltage that is one step smaller in the following list:

330, 500, 800, 1 500, 2 500, 4 000, 6 000 and 8 000 V_{peak}.

However, this reduction is not permitted for a floating SECONDARY CIRCUIT unless it is in equipment with a main protective earthing terminal and is separated from its PRIMARY CIRCUIT by an earthed metal screen, connected to protective earth in accordance with 2.6.

Alternatively, the above rules 1) and 2) are applied but the voltage determined by measurement, see G.5 a), is taken as the MAINS TRANSIENT VOLTAGE.

- PRIMARY and SECONDARY CIRCUITS not receiving the unattenuated mains transient:

In such PRIMARY or SECONDARY CIRCUITS, the REQUIRED WITHSTAND VOLTAGE, ignoring the effect of transients coming from any TELECOMMUNICATION NETWORK, is determined as follows. The above rules 1) and 2) are applied, but a voltage determined by measurement, see G.5 a), shall be taken as the MAINS TRANSIENT VOLTAGE.

- SECONDARY CIRCUIT supplied by a d.c. source having capacitive filtering:

In any earthed SECONDARY CIRCUIT supplied by a d.c. source with capacitive filtering, the REQUIRED WITHSTAND VOLTAGE shall be taken as equal to the DC VOLTAGE.

b) TELECOMMUNICATION NETWORK transients

If transients only from a TELECOMMUNICATION NETWORK are involved, the REQUIRED WITHSTAND VOLTAGE is the TELECOMMUNICATION NETWORK TRANSIENT VOLTAGE determined in G.3, unless a lower level is measured when tested according to G.5 b).

c) Combination of transients

If both transients a) and b) are involved, the REQUIRED WITHSTAND VOLTAGE is the larger of the two voltages. The two values shall not be added together.

G.5 Measurement of transient levels

The following tests are conducted only where it is required to determine whether or not transient voltage across the CLEARANCE in any circuit is lower than normal, due for example, to the effect of a filter in the equipment. The transient voltage across the CLEARANCE is measured using the following test procedure.

During the tests, the equipment is connected to its separate power supply unit, if any, but is not connected to the mains, nor to any TELECOMMUNICATION NETWORKS, and any surge suppressors in PRIMARY CIRCUITS are disconnected.

A voltage measuring device is connected across the CLEARANCE in question.

a) To measure the reduced level of transients due to mains overvoltages, the impulse test generator of annex N is used to generate 1,2/50 μ s impulses, with U_c equal to the MAINS TRANSIENT VOLTAGE determined in G.2.

Three to six impulses of alternating polarity, with intervals of at least 1 s between impulses, are applied between each of the following points where relevant:

- *line-to-line;*
- *all line conductors conductively joined together and neutral;*
- *all line conductors conductively joined together and protective earth;*
- *neutral and protective earth.*

b) To measure the reduced level of transients due to TELECOMMUNICATION NETWORK overvoltages, the impulse test generator of annex N is used to generate 10/700 μ s impulses, with U_c equal to the TELECOMMUNICATION NETWORK TRANSIENT VOLTAGE determined in G.3.

Three to six impulses of alternating polarity, with intervals of at least 1 s between impulses, are applied between each of the following TELECOMMUNICATION NETWORK connection points of a single interface type:

- each pair of terminals (e.g. A and B or tip and ring) in an interface;
- all terminals of a single interface type joined together and earth.

Only one of a set of identical circuits is tested.

G.6 Determination of minimum clearances

For equipment to be operated up to 2 000 m above sea level, each CLEARANCE shall comply with the minimum dimensions given in table G.2, using the value of REQUIRED WITHSTAND VOLTAGE determined according to G.4.

For equipment to be operated at more than 2 000 m above sea level, table A.2 of IEC 60664-1:1992 shall be used instead of table G.2.

Except as required by 2.8.7.1, the specified CLEARANCES are not applicable to the air gap between the contacts of THERMOSTATS, THERMAL CUT-OUTS, overload protection devices, switches of microgap construction and similar components where the air gap varies with the contacts.

NOTE 1 – For air gaps between contacts of disconnect devices, see 3.4.2. For air gaps between the contacts of interlock switches, see 2.8.7.1.

The specified CLEARANCES are subject to the following minimum values:

- 10 mm for an air gap serving as REINFORCED INSULATION between a part at HAZARDOUS VOLTAGE and an accessible conductive part of the ENCLOSURE of floor-standing equipment or of the non-vertical top surface of desk-top equipment;
- 2 mm for an air gap serving as BASIC INSULATION between a part at HAZARDOUS VOLTAGE and an accessible conductive part of the external ENCLOSURE of PLUGGABLE EQUIPMENT TYPE A.

NOTE 2 – CLEARANCES should not be reduced below the minimum specified values by manufacturing tolerances or by deformation which can occur due to handling, shock and vibration likely to be encountered during manufacture, transport and normal use.

Table G.2 – Minimum clearances up to 2 000 m above sea level

Required WITHSTAND VOLTAGE V peak or d.c.	CLEARANCES in millimetres		
	Minimum CLEARANCES in air		
	FUNCTIONAL INSULATION	BASIC and SUPPLEMENTARY INSULATION	REINFORCED INSULATION
Up to 400	0,1	0,2 (0,1)	0,4 (0,2)
800	0,1	0,2	0,4
1 000	0,2	0,3	0,6
1 200	0,3	0,4	0,8
1 500	0,5		1,6 (1)
2 000	1	1,3 (1)	2,6 (2)
2 500	1,5	2 (1,5)	4 (3)
3 000	2	2,6 (2)	5,2 (4)
4 000	3	4 (3)	6
6 000	5,5	7,5	11
8 000	8	11	16
10 000	11	15	22
12 000	14	19	28
15 000	18	24	36
25 000	33	44	66
40 000	60	80	120
50 000	75	100	150
60 000	90	120	180
80 000	130	173	260
100 000	170	227	340

1) Except in PRIMARY CIRCUITS in G.4 a), linear interpolation is permitted between the nearest two points, the calculated minimum CLEARANCES being rounded up to the next higher 0,1 mm increment.

2) The values in parentheses are applicable only if manufacturing is subjected to a quality control programme, that provides at least the same level of assurance as the example given in clause R.2. In particular, DOUBLE and REINFORCED INSULATION shall be subjected to ROUTINE TESTS for electric strength.

3) Compliance with a CLEARANCE value of 8,4 mm or greater for SECONDARY CIRCUITS is not required if the CLEARANCE path is:

- entirely through air; or
- wholly or partly along the surface of an insulation of Material Group I;

and the insulation involved passes an electric strength test according to 5.2.2, using:

- an a.c. test voltage whose r.m.s. value is equal to 1,06 times the PEAK WORKING VOLTAGE; or
- a d.c. test voltage equal to the peak value of the a.c. test voltage prescribed above.

If the CLEARANCE path is partly along the surface of a material that is not of Material Group I, the electric strength test is conducted in the air gap only.

Compliance is checked by measurement, taking into account annex F.

The following conditions are applicable.

Movable parts are placed in their most unfavourable positions.

When measuring CLEARANCES from an ENCLOSURE of insulating material through a slot or opening in the ENCLOSURE, the accessible surface is considered to be conductive as if it were covered by metal foil wherever it can be touched by the test finger, of figure 2A (see 2.1.1.1), applied without appreciable force (see figure F.12, point B).

When measuring CLEARANCES, the force tests of 4.2.2, 4.2.3 and 4.2.4 are to be applied.

Annex H
(normative)
Ionizing radiation
(see 4.3.13)

Equipment which might produce ionizing radiation is checked by measuring the amount of radiation.

The amount of radiation is determined by means of a radiation monitor of the ionizing chamber type with an effective area of 10 cm² or by measuring equipment of other types giving equivalent results.

Measurements are made with the equipment on test operating at the most unfavourable supply voltage (see 1.4.5) and with OPERATOR controls and service controls adjusted so as to give maximum radiation whilst maintaining the equipment operative for normal use.

Internal preset controls not intended to be adjusted during the lifetime of the equipment are not considered to be service controls.

At any point 5 cm from the surface of the OPERATOR ACCESS AREA the dose-rate shall not exceed 36 pA/kg (0,5 mR/h) (see note). Account is taken of the background level.

NOTE – This value appears in ICRP 15.

Annex J
(normative)
Table of electrochemical potentials
(see 2.6.5.6)

**Table J.1
Electrochemical potentials**

Reference Electrode	Magnesium, magnesium alloys	Zinc, zinc alloys	80 tin/20 Zn on steel, Zn on iron or steel	Aluminium	Cd on steel	Al/Mg alloy	Mild steel	Duralumin	Lead	Cr on steel, soft solder	Cr on Ni on steel, tin on steel, 12 % Cr stainless steel	High Cr stainless steel	Copper, copper alloys	Silver solder, Austenitic stainless steel	Ni on steel	Silver	Rh on Ag on Cu, silver/gold alloy	Carbon	Gold, platinum
Ag	0	0.05	0	0	0	0	0	0	0	0	0	0	0	0	0	0	0	0	0
Al	0.05	0	0.05	0	0	0	0	0	0	0	0	0	0	0	0	0	0	0	0
Aluminium	0.05	0	0.05	0	0	0	0	0	0	0	0	0	0	0	0	0	0	0	0
Al/Mg alloy	0.05	0	0.05	0	0	0	0	0	0	0	0	0	0	0	0	0	0	0	0
Mild steel	0.05	0	0.05	0	0	0	0	0	0	0	0	0	0	0	0	0	0	0	0
Duralumin	0.05	0	0.05	0	0	0	0	0	0	0	0	0	0	0	0	0	0	0	0
Lead	0.05	0	0.05	0	0	0	0	0	0	0	0	0	0	0	0	0	0	0	0
Cr on steel, soft solder	0.05	0	0.05	0	0	0	0	0	0	0	0	0	0	0	0	0	0	0	0
Cr on Ni on steel, tin on steel, 12 % Cr stainless steel	0.05	0	0.05	0	0	0	0	0	0	0	0	0	0	0	0	0	0	0	0
High Cr stainless steel	0.05	0	0.05	0	0	0	0	0	0	0	0	0	0	0	0	0	0	0	0
Copper, copper alloys	0.05	0	0.05	0	0	0	0	0	0	0	0	0	0	0	0	0	0	0	0
Silver solder, Austenitic stainless steel	0.05	0	0.05	0	0	0	0	0	0	0	0	0	0	0	0	0	0	0	0
Ni on steel	0.05	0	0.05	0	0	0	0	0	0	0	0	0	0	0	0	0	0	0	0
Silver	0.05	0	0.05	0	0	0	0	0	0	0	0	0	0	0	0	0	0	0	0
Rh on Ag on Cu, silver/gold alloy	0.05	0	0.05	0	0	0	0	0	0	0	0	0	0	0	0	0	0	0	0
Carbon	0.05	0	0.05	0	0	0	0	0	0	0	0	0	0	0	0	0	0	0	0
Gold, platinum	0.05	0	0.05	0	0	0	0	0	0	0	0	0	0	0	0	0	0	0	0
Magnesium, magnesium alloys	0	0.05	0	0	0	0	0	0	0	0	0	0	0	0	0	0	0	0	0
Zinc, zinc alloys	0	0.05	0	0	0	0	0	0	0	0	0	0	0	0	0	0	0	0	0
80 tin/20 Zn on steel, Zn on iron or steel	0	0.05	0	0	0	0	0	0	0	0	0	0	0	0	0	0	0	0	0
Aluminium	0	0.05	0	0	0	0	0	0	0	0	0	0	0	0	0	0	0	0	0
Cd on steel	0	0.05	0	0	0	0	0	0	0	0	0	0	0	0	0	0	0	0	0
Al/Mg alloy	0	0.05	0	0	0	0	0	0	0	0	0	0	0	0	0	0	0	0	0
Mild steel	0	0.05	0	0	0	0	0	0	0	0	0	0	0	0	0	0	0	0	0
Duralumin	0	0.05	0	0	0	0	0	0	0	0	0	0	0	0	0	0	0	0	0
Lead	0	0.05	0	0	0	0	0	0	0	0	0	0	0	0	0	0	0	0	0
Cr on steel, soft solder	0	0.05	0	0	0	0	0	0	0	0	0	0	0	0	0	0	0	0	0
Cr on Ni on steel, tin on steel, 12 % Cr stainless steel	0	0.05	0	0	0	0	0	0	0	0	0	0	0	0	0	0	0	0	0
High Cr stainless steel	0	0.05	0	0	0	0	0	0	0	0	0	0	0	0	0	0	0	0	0
Copper, copper alloys	0	0.05	0	0	0	0	0	0	0	0	0	0	0	0	0	0	0	0	0
Silver solder, Austenitic stainless steel	0	0.05	0	0	0	0	0	0	0	0	0	0	0	0	0	0	0	0	0
Ni on steel	0	0.05	0	0	0	0	0	0	0	0	0	0	0	0	0	0	0	0	0
Silver	0	0.05	0	0	0	0	0	0	0	0	0	0	0	0	0	0	0	0	0
Rh on Ag on Cu, silver/gold alloy	0	0.05	0	0	0	0	0	0	0	0	0	0	0	0	0	0	0	0	0
Carbon	0	0.05	0	0	0	0	0	0	0	0	0	0	0	0	0	0	0	0	0
Gold, platinum	0	0.05	0	0	0	0	0	0	0	0	0	0	0	0	0	0	0	0	0

NOTE — Corrosion due to electrochemical action between dissimilar metals which are in contact is minimized if the combined electrochemical potential is below about 0.6 V. In the table the combined electrochemical potentials are listed for a number of pairs of metals in common use; combinations above the dividing line should be avoided.

S3426D

Annex K
(normative)
Thermal controls
(see 1.5.3 and 5.3.7)

K.1 Making and breaking capacity

THERMOSTATS and TEMPERATURE LIMITERS shall have adequate making and breaking capacity.

Compliance is checked by subjecting three samples either to the tests of clauses K.2 and K.3, or to the tests of clause K.4, as appropriate. If the component is T-marked, one sample is tested with the switch part at room temperature, and two samples with the switch part at a temperature in accordance with the marking.

Components not marked with individual ratings are tested either in the equipment or separately, whichever is more convenient, but, if tested separately, the test conditions are to be similar to those occurring in the equipment.

During the tests, no sustained arcing shall occur.

After the tests, the samples shall show no damage impairing their further use. Electrical connections shall not have worked loose. The component shall withstand an electric strength test as specified in 5.2.2, except that the test voltage for the insulation between the contacts is twice the voltage applied when the equipment is operated at RATED VOLTAGE or at the upper voltage of the RATED VOLTAGE RANGE.

For test purposes the switching frequency can be increased above the normal switching frequency inherent to the equipment, provided that no greater risk of failure is induced.

If it is not possible to test the component separately, three samples of the equipment in which it is used are tested.

K.2 Thermostat reliability

THERMOSTATS are caused, thermally, to perform 200 cycles of operation (200 makes and 200 breaks) when the equipment is operated at a voltage equal to 1,1 times RATED VOLTAGE or to 1,1 times the upper voltage of the RATED VOLTAGE RANGE, and under NORMAL LOAD.

K.3 Thermostat endurance test

THERMOSTATS are caused, thermally, to perform 10 000 cycles of operation (10 000 makes and 10 000 breaks) when the equipment is operated at RATED VOLTAGE or at the upper voltage of the RATED VOLTAGE RANGE, and under NORMAL LOAD.

K.4 Temperature limiter endurance

TEMPERATURE LIMITERS are caused, thermally, to perform 1 000 cycles of operation (1 000 makes and 1 000 breaks) when the equipment is operated at RATED VOLTAGE, or at the upper voltage of the RATED VOLTAGE RANGE, and under NORMAL LOAD.

K.5 Thermal cut-out reliability

THERMAL CUT-OUTS shall operate reliably.

Compliance is checked while the equipment is operating under the conditions specified in 4.5.1.

AUTOMATIC RESET THERMAL CUT-OUTS are caused to operate 200 times; MANUAL RESET THERMAL CUT-OUTS are reset after each operation and thus caused to operate 10 times.

After the tests, the samples shall show no damage impairing their further use.

Forced cooling and resting periods are permitted to prevent damage to the equipment.

K.6 Stability of operation

THERMOSTATS, TEMPERATURE LIMITERS and THERMAL CUT-OUTS shall be so constructed that their setting is not changed appreciably by heating, vibration, etc., occurring in normal use.

Compliance is checked by inspection during the abnormal operation tests of 5.3.

Annex L (normative)

Normal load conditions for some types of electrical business equipment (see 1.2.2.1 and 4.5.1)

L.1 Typewriters

Typewriters are energized with no load applied until steady conditions are established. Manually keyed machines are then operated at a rate of 200 characters per minute, with a line transport operation after each 60 characters including spaces, until steady conditions are established. Automatically operated machines are operated at the maximum typing speed recommended in the manufacturer's instruction sheet.

L.2 Adding machines and cash registers

For adding machines and cash registers, four digit numbers are entered or set and the repeat key or operating bar activated 24 times per minute, until steady conditions are established, the four digit number to be used being that which loads the machine most heavily. If the cash register has a drawer which opens every time an item is rung up, the cash register is operated at a rate of 15 operation cycles per minute, the drawer being shut after each operation, until steady conditions are established. For an adding machine or cash register, an operation consists of the OPERATOR setting or inserting the figures with which the machine is to operate and then pressing the operating bar, repeating key or the like for each operation.

L.3 Erasers

Erasers are operated continuously at no load for 1 h.

L.4 Pencil sharpeners

For a pencil sharpener, five new pencils are each sharpened eight times according to the following timetable. Except for new pencils, the point is broken off before each sharpening.

Sharpening period	4 s for a new pencil
	2 s for subsequent sharpenings
Interval between sharpenings	6 s
Interval between pencils	60 s

All times are approximate.

L.5 Duplicators and copy machines

Duplicators and copy machines are operated continuously at maximum speed until steady conditions are established. It is permitted to introduce a rest period of 3 min after each 500 copies if this is compatible with the design of the machine.

L.6 Motor-operated files

Motor-operated files are loaded to simulate a condition of unbalance caused by uneven distribution of the contents. During operation, the unbalanced load is moved approximately one-third of the total carrier travel of the path that will impose maximum loading during each operation. The operation is repeated each 15 s until steady conditions are established.

A load caused by the non-uniform distribution of the content is permitted to be simulated as follows.

In the case of vertical transport, three-eighths of the filing area are to be loaded, without leaving clearances, with three-eighths of the admissible load. The entire transport way is to be travelled with this load. The transport cycle is to be repeated, at intervals of 10 s, until the temperature has stabilized.

In the case of a different transport, for example horizontal or circular mode of transport, the total load is moved over the whole transport way. The transport cycle is to be repeated, at intervals of 15 s, until the temperature has stabilized.

L.7 Other business equipment

Other business equipment is operated according to the most unfavourable way of operation given in the operating instructions.

Annex M
(normative)
Criteria for telephone ringing and other signals
(see 2.3.1)

DE

M.1 Introduction

The two alternative methods described in this annex reflect satisfactory experience in different parts of the world. Method A is typical of analogue telephone networks in Europe, and Method B of those in North America. The two methods result in standards of electrical safety which are broadly equivalent.

M.2 Method A

This method requires that the currents I_{TS1} and I_{TS2} flowing through a 5 000 Ω resistor, between any two conductors or between one conductor and earth do not exceed the limits specified, as follows:

a) I_{TS1} , the current determined from the calculated or measured current for any single active ringing period t_1 (as defined in figure M.1), does not exceed:

– for cadenced ringing ($t_1 < \infty$), the current given by the curve of figure M.2 at t_1 ; or

– for continuous ringing ($t_1 = \infty$), 16 mA, or 20 mA where cadenced ringing becomes continuous as a consequence of a single fault;

Continuous ringing signals shall:

D2

• be located in SERVICE ACCESS AREAS;

D2

• be so located and guarded that unintentional contact with such parts is unlikely during service operations, or be provided with a marking to warn SERVICE PERSONNEL of the presence of continuous ringing signals; and

D2

D2

D2

• not become OPERATOR accessible under single fault conditions.

D2

where I_{TS1} , in mA, is as given by:

$$I_{TS1} = \frac{I_p}{\sqrt{2}} \quad \text{for } (t_1 \leq 600 \text{ ms})$$

$$I_{TS1} = \frac{t_1 - 600}{600} \times \frac{I_{pp}}{2\sqrt{2}} + \frac{1\ 200 - t_1}{600} \times \frac{I_p}{\sqrt{2}} \quad \text{for } (600 \text{ ms} < t_1 < 1\ 200 \text{ ms})$$

$$I_{TS1} = \frac{I_{pp}}{2\sqrt{2}} \quad \text{for } (t_1 \geq 1\ 200 \text{ ms})$$

where:

I_p is the peak current, in mA, of the relevant waveform given in figure M.3;

I_{pp} is the peak-to-peak current, in mA, of the relevant waveform given in figure M.3;

t_1 is expressed in ms.

b) I_{TS2} , the average current for repeated bursts of a cadenced ringing signal calculated for one ringing cadence cycle t_2 (as defined in figure M.1), does not exceed 16 mA r.m.s.; where I_{TS2} in mA is as given by:

$$I_{TS2} = \left[\frac{t_1}{t_2} \times I_{TS1}^2 + \frac{t_2 - t_1}{t_2} \times \frac{I_{dc}^2}{3,75^2} \right]^{1/2}$$

where:

I_{TS1} in mA, is as given by M.2 a);

I_{dc} is the d.c. current in mA flowing through the 5 000 Ω resistor during the non-active period of the cadence cycle;

t_1 and t_2 are expressed in milliseconds.

NOTE – The frequencies of telephone ringing voltages are normally within the range of 14 Hz to 50 Hz.

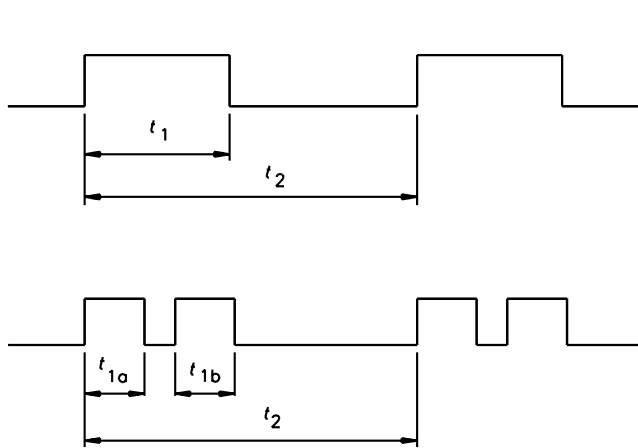

SM433B

t_1 is:

- the duration of a single ringing period, where the ringing is active for the whole of the single ringing period;
- the sum of the active periods of ringing within the single ringing period, where the single ringing period contains two or more discrete active periods of ringing, as in the example shown, for which $t_1 = t_{1a} + t_{1b}$;

t_2 is the duration of one complete cadence cycle.

Figure M.1 – Definition of ringing period and cadence cycle

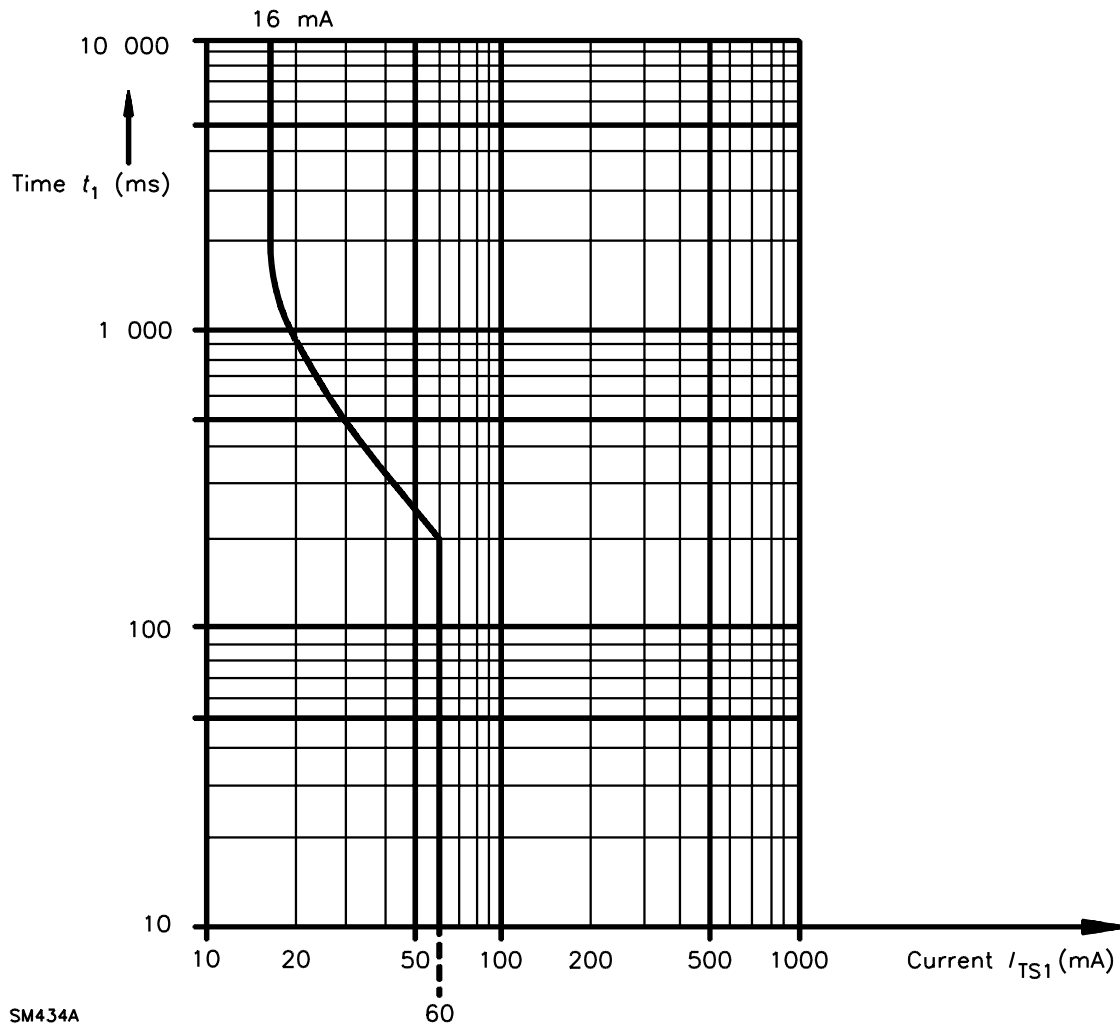

Note – The curve is based on curve "b" of figure 14 of IEC 60479-1:1994.

Figure M.2 – I_{TS1} limit curve for cadenced ringing signal

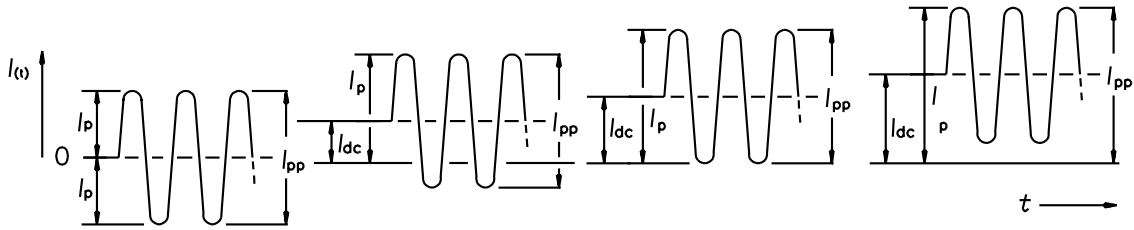

SM435A

Figure M.3 – Peak and peak-to-peak currents**M.3 Method B**

NOTE – This method is based on USA CFR 47 (“FCC Rules”) Part 68, Sub-part D, with additional requirements that apply under fault conditions.

M.3.1 Ringing signal**M.3.1.1 Frequency**

The ringing signal shall use only frequencies whose fundamental component is equal to or less than 70 Hz.

M.3.1.2 Voltage

The ringing voltage shall be less than 300 V peak-to-peak and less than 200 V peak with respect to earth, measured across a resistance of at least 1 M Ω .

M.3.1.3 Cadence

The ringing voltage shall be interrupted to create quiet intervals of at least 1 s duration separated by no more than 5 s. During the quiet intervals, the voltage to earth shall not exceed 56,5 V d.c.

M.3.1.4 Single fault current

Where cadenced ringing becomes continuous as a consequence of a single fault, the current through a 5 000 Ω resistor connected between any two output conductors or between one output conductor and earth shall not exceed 56,5 mA peak-to-peak, as shown in figure M.3.

M.3.2 Tripping device and monitoring voltage

M.3.2.1 Conditions for use of a tripping device or a monitoring voltage

A ringing signal circuit shall include a tripping device as specified in M.3.2.2, or provide a monitoring voltage as specified in M.3.2.3, or both, depending on the current through a specified resistance connected between the ringing signal generator and earth, as follows:

- if the current through a 500 Ω resistor does not exceed 100 mA peak-to-peak, neither a tripping device nor a monitoring voltage is required;
- if the current through a 1 500 Ω resistor exceeds 100 mA peak-to-peak, a tripping device shall be included. If the tripping device meets the trip criteria specified in figure M.4 with $R = 500 \Omega$, no monitoring voltage is required. If, however, the tripping device only meets the trip criteria with $R = 1 500 \Omega$, a monitoring voltage shall also be provided;
- if the current through a 500 Ω resistor exceeds 100 mA peak-to-peak, but the current through a 1 500 Ω resistor does not exceed this value, either:
 - a tripping device shall be provided, meeting the trip criteria specified in figure M.4 with $R = 500 \Omega$ or
 - a monitoring voltage shall be provided.

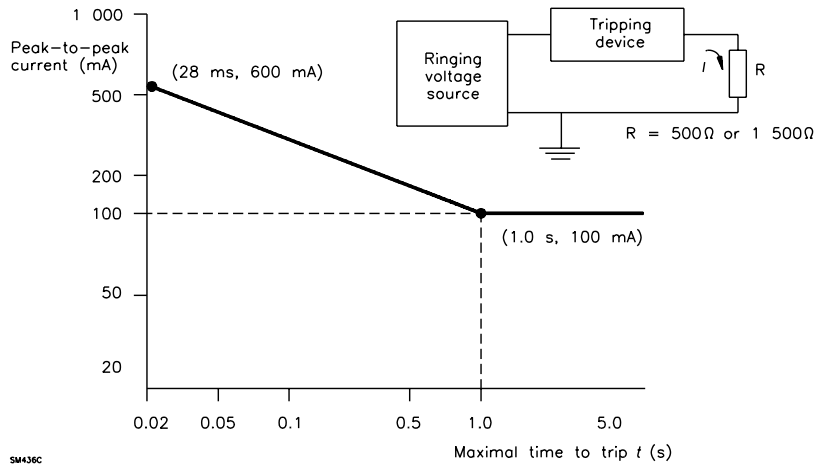

NOTES

- 1 t is measured from the time of connection of the resistor R to the circuit.
- 2 The sloping part of the curve is defined as $I = 100/\sqrt{t}$.

Figure M.4 – Ringing voltage trip criteria

M.3.2.2 Tripping device

A series current-sensitive tripping device in the ringlead which will trip ringing as specified in figure M.4.

M.3.2.3 Monitoring voltage

A voltage to earth on the tip or ring conductor with a magnitude of at least 19 V peak, but not exceeding 56,5 V d.c., whenever the ringing voltage is not present (idle state).

Annex N
(normative)
Impulse test generators
(see 2.10.3.4, 6.2.2.1 and G.5)

The circuit in figure N.1, using the component values in table N.1, is used to generate impulses, the C_1 capacitor being charged initially to a voltage U_c .

The impulse test circuit for the 10/700 μs (10 μs virtual front time, 700 μs virtual time to half value) impulse is that specified in ITU-T Recommendation K.17 to simulate lightning interference in the TELECOMMUNICATION NETWORK.

The impulse test circuit for the 1,2/50 μs (1,2 μs virtual front time, 50 μs virtual time to half value) impulse is that specified in ITU-T Recommendation K.21 to simulate transients in power distribution systems.

The impulse wave shapes are under open-circuit conditions and can be different under load conditions.

NOTE – Extreme care is necessary when using these generators due to the high electric charge stored in the capacitor C_1 .

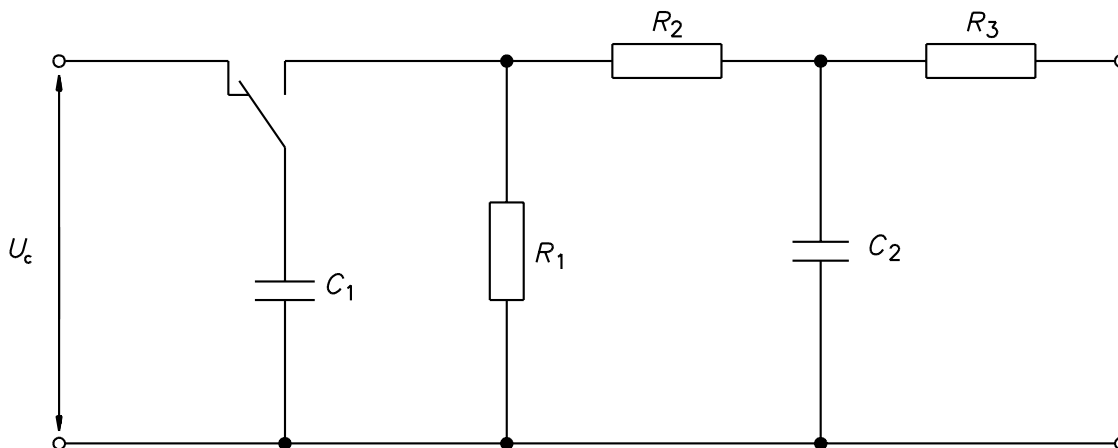

SM437B

Figure N.1 – Impulse generating circuit

Table N.1 — Component values for impulse generating circuits

Test impulse	C₁	R₁	R₂	C₂	R₃	See subclause
10/700 μ s	20 μ F	50 Ω	15 Ω	0.2 μ F	25 Ω	2.10.3.4, 6.2.2.1 and G.5 b)
1,2/50 μ s	1 μ F	76 Ω	13 Ω	33 nF	25 Ω	2.10.3.4 and G.5

Annex P
(normative)
Normative references

The following normative documents contain provisions which, through reference in this text, constitute provisions of this International Standard. For dated references, subsequent amendments to, or revisions of, any of these publications do not apply. However, parties to agreements based on this International Standard are encouraged to investigate the possibility of applying the most recent editions of the normative documents indicated below. For undated references, the latest edition of the normative document referred to applies. Members of IEC and ISO maintain registers of currently valid International Standards.

IEC 60050-151, *International Electrotechnical Vocabulary – Chapter 151: Electrical and magnetic devices*

IEC 60050-195, *International Electrotechnical Vocabulary – Chapter 195: Earthing and protection against electric shock*

IEC 60065: 1985, *Safety requirements for mains operated electronic and related apparatus for household and similar general use*

IEC 60073: 1996, *Basic and safety principles for man-machine interface, marking and identification – Coding principles for indicating devices and actuators*

IEC 60085: 1984, *Thermal evaluation and classification of electrical insulation*

IEC 60112: 1979, *Method for determining the comparative and the proof tracking indices of solid insulating material under moist conditions*

IEC 60227 (all parts), *Polyvinyl chloride insulated cables of rated voltages up to and including 450/750 V*

IEC 60245 (all parts), *Rubber insulated cables – Rated voltages up to and including 450/750 V*

IEC 60309 (all parts), *Plugs, socket-outlets and couplers for industrial purposes*

IEC 60318: 1970, *An artificial ear, of the wideband type, for the calibration of earphones used in audiometry* DE
DE

IEC 60320 (all parts), *Appliance couplers for household and similar general purposes*

IEC 60364-3: 1993, *Electrical installations of buildings – Part 3: Assessment of general characteristics*

IEC 60364-4-41: 1992 *Electrical installations of buildings – Part 4: Protection for safety – Chapter 41: Protection against electric shock*

IEC 60384-14: 1993, *Fixed capacitors for use in electronic equipment – Part 14: Sectional specification: Fixed capacitors for electromagnetic interference suppression and connection to the supply mains*

IEC 60417-1: 1998, *Graphical symbols for use on equipment. Index, survey and compilation of the single sheets*

IEC 60651: 1979, *Sound level meters*

DE

IEC 60664-1: 1992, *Insulation coordination for equipment within low-voltage systems – Part 1: Principles, requirements and tests*

IEC 60695-2-1/1: 1994, *Fire hazard testing – Part 2: Test Methods – Section 1/Sheet 1: Glow-wire end-product test and guidance*

IEC 60695-2-2: 1991, *Fire hazard testing – Part 2: Test methods – Section 2: Needle-flame test*

IEC 60695-10-2: 1995 *Fire hazard testing – Part 10: Guidance and test methods for the minimization of the effects of abnormal heat on electrotechnical products involved in fires – Section 2: Method for testing products made from non-metallic materials for resistance to heat using the ball pressure test*

IEC 60730-1: 1993, *Automatic electrical controls for household and similar use – Part 1: General requirements.*

IEC 60825-1: 1997, *Safety of laser products IEC 60825-1: 1997, Safety of laser products – Part 1: Equipment classification, requirements and user's guide*

IEC 60851-3: 1996, *Methods of test for winding wires – Part 3: Mechanical properties*

IEC 60851-5: 1996, *Methods of test for winding wires – Part 5: Electrical properties*

IEC 60851-6: 1996, *Methods of test for winding wires – Part 6: Thermal properties*

IEC 60885-1: 1987, *Electrical test methods for electric cables – Part 1: Electrical tests for cables, cords and wires for voltages up to and including 450/750 V*

IEC 61058-1: 1996, *Switches for appliances – Part 1: General requirements*

ISO 261: 1973, *ISO General purpose metric screw threads – General plan*

ISO 262: 1973, *ISO General purpose metric screw threads – Selected sizes for screws, bolts and nuts*

ISO 3864: 1984, *Safety colours and safety signs*

ISO 4046: 1978, *Paper, board, pulp and related terms – Vocabulary*

ISO 7000: 1989, *Graphical symbols for use on equipment – Index and synopsis*

Other publications

ITU-T Recommendation K.17: 1988, *Tests on power-fed repeaters using solid-state devices in order to check the arrangements for protection from external interference*

ITU-T Recommendation K.21: 1988, *Resistibility of subscribers' terminals to overvoltages and overcurrents*

P.1 UL and CSA Component Requirements (mandatory) DC

Annex P.1 DC

NOTE 1 – The complete text of Annex P.1 is a DC deviation. DC

NOTE 2 – Please note that underlining to indicate text added to IEC 60950 is not used in this portion of annex P. DC

All IEC component standard requirements in this standard are replaced by the relevant requirements of CSA and UL component standards as listed in this annex. DC
DC

Products which are determined to comply with clauses 1 – 6 and applicable annexes of this standard are considered to comply with UL and CSA requirements except that components may require additional evaluation to determine compliance with IEC 60950 requirements. DC
DC
DC

Any undated reference to a code or standard appearing in the requirements of this standard shall be interpreted as referring to the latest edition of that code or standard. DC
DC

If no standard is listed, requirements are assumed to be those in IEC 60950. DC

The following components shall comply with the requirements specified below. All IEC standard requirements in this standard are either replaced or modified, as noted, by the relevant requirements of either CSA or UL or both component standards as listed in this annex. DC
DC
DC

Annex P.1 DC

Sub-clause from this standard	Component type	UL standard	CSA standard	IEC publication (shall be replaced by UL and/or CSA Standard)
1.1.2 annex T *	Enclosures for electrical equipment	UL 50 <i>Enclosures for Electrical Equipment</i>	CAN/CSA C22.2 No. 94 <i>Special Purpose Enclosures</i>	
1.5.2 *	Edison-base lampholders	UL 496 <i>Edison-Base Lampholders</i>	CSA C22.2 No. 43 <i>Lampholders</i>	
1.5.2 *	Ground-fault circuit-interrupters	UL 943 <i>Ground-Fault Circuit-Interrupters</i>	CAN/CSA C22.2 No. 144 <i>Ground-Fault Circuit-Interrupters</i>	
1.5.2 **	Surge suppressors	UL 1449 <i>Transient Voltage Surge Suppressors</i>	Certification Notice No. 516 (Where the surge suppressor is relied upon to achieve Overvoltage Category 1, UL 1449 requirements apply)	
1.5.2	Printed-wiring boards	UL 796 <i>Printed Wiring Boards</i>		
2.7 *	Circuit breakers	UL 489 <i>Molded-Case Circuit Breakers and Circuit-Breaker Enclosures</i>	CAN/CSA C22.2 No. 5.1 <i>Moulded Case Circuit Breakers</i>	
2.7 *	Fuseholders	UL 512 <i>Fuseholders</i>	CSA C22.2 No. 39 <i>Fuseholder Assemblies</i>	

Annex P.1 Continued

DC

Sub-clause from this standard	Component type	UL standard	CSA standard	IEC publication (shall be replaced by UL and/or CSA Standard)
2.7 *	Fuses (branch circuit applications)	UL 248-1 <i>Low-Voltage Fuses – Part 1: General Requirements</i> UL 248-4 <i>Low-Voltage Fuses – Part 4: Class CC Fuses</i> UL 248-8 <i>Low-Voltage Fuses – Part 8: Class J Fuses</i> UL 248-10 <i>Low-Voltage Fuses – Part 10: Class L Fuses</i> UL 248-12 <i>Low-Voltage Fuses – Part 12: Class R Fuses</i> UL 248-15 <i>Low-Voltage Fuses – Part 15: Class T Fuses</i>	CSA C22.2 No. 248 <i>Series Low Voltage Fuses</i> CSA C22.2 No. 248.1 <i>Part 1: General Requirements</i> CSA C22.2 No. 248.4 <i>Part 4: Class CC Fuses</i> CSA C22.2 No. 248.8 <i>Part 8: Class J Fuses</i> CSA C22.2 No. 248.10 <i>Part 10: Class L Fuses</i> CSA C22.2 No. 248.12 <i>Part 12: Class R Fuses</i> CSA C22.2 No. 248.15 <i>Part 15: Class T Fuses</i>	IEC 127-1 <i>Miniature fuses. Part 1: definitions for miniature fuses and general requirements for miniature fuse-links.</i>
2.7 *	Supplementary protectors	UL 1077 <i>Supplementary Protectors for Use in Electrical Equipment</i>	CAN/CSA C22.2 No. 235 <i>Supplementary Protectors</i>	
2.8.4 *	Solid-state controls	UL 244A <i>Solid-State Controls for Appliances</i>	CSA C22.2 No. 156 <i>Solid-State Speed Controls</i>	
2.8.7 *	Limit controls	UL 353 <i>Limit Controls</i>	CSA C22.2 No. 24 <i>Temperature-Indicating and -Regulating Equipment</i>	
2.8.7, 3.4	Switches	See 3.4		IEC 1058-1: <i>Switches for Appliances Part 1: General Requirements</i>
2.9.1 *	Insulating tubing	UL 224 <i>Extruded Insulating Tubing</i>	CSA C22.2 No. 198.1 <i>Extruded Insulating Tubing</i>	
2.9.1 *	Insulating tape	UL 510 <i>Electrical Insulating Tape</i>	CSA C22.2 No. 197 <i>PVC Insulating Tape</i> (For other than PVC tape, UL 510 applies)	
2.10.5.4, Annex U *	Insulated transformer winding wiring (supplements requirements in 2.10.5.4/ Annex U)	Subject 758 <i>Appliance Wiring Material</i>	CAN/CSA C22.2 No. 210.2 <i>Appliance Wiring Material Products</i>	
3.1 *	Wires and cables	UL 44 <i>Rubber-Insulated Wires and Cables</i> UL 83 <i>Thermoplastic-Insulated Wires and Cables</i> UL 758 <i>Appliance Wiring Material</i>	CSA C22.2 No. 35 <i>Extra-Low-Voltage Control Circuit Cables, Low-Energy Control Cable, and Extra-Low Voltage Control Cable</i> CSA C22.2 No. 127 <i>Equipment/Lead Wires</i> CAN/CSA C22.2 No. 210.2 <i>Appliance Wiring Material Products</i>	

Annex P.1 Continued

DC

Sub-clause from this standard	Component type	UL standard	CSA standard	IEC publication (shall be replaced by UL and/or CSA Standard)
3.2.5, 4.3.6 **	Attachment plugs, receptacles, and connectors	UL 498 Attachment Plugs and Receptacles	CSA C22.2 No. 42 <i>General Use Receptacles, Attachment Plugs, and Similar Wiring Devices</i> CSA C22.2 No. 182.1 <i>Industrial Type, Special Use Attachment Plugs, Receptacles, and Connectors</i> CSA C22.2 No. 182.2 <i>Industrial Locking Type, Special Use Attachment Plugs, Receptacles, and Connectors</i> CSA C22.2 No. 182.3 <i>Special Use Attachment Plugs, Receptacles, and Connectors</i> (T-type receptacle is not acceptable)	IEC 83: 1975 <i>Plugs and socket-outlets for domestic and similar general use</i> IEC 309: 1988, 1989 <i>Plugs, socket-outlets and couplers for industrial purposes</i> IEC 320: 1981 <i>Appliance couplers for household and similar general purposes</i>
3.2.5 *	Cord sets and power supply cords	UL 817 <i>Cord Sets and Power-Supply Cords</i>	CSA C22.2 No. 21 <i>Cord Sets and Power Supply Cords</i>	
3.2.5 *	Flexible cords and cables	UL 62 <i>Flexible Cord and Fixture Wire</i>	CSA C22.2 No. 49 <i>Flexible Cords and Cables</i> CAN/CSA C22.2 No. 96 <i>Portable Power Cables</i>	IEC 227: 1979 <i>Polyvinyl chloride insulated cables of rated voltages up to and including 450/750 V</i> IEC 245: 1980, 1985 <i>Rubber insulated cables of rated voltages up to and including 450/750 V</i> IEC 885-1: 1987 <i>Electrical test methods for electric cables. Part 1: Electrical tests for cables, cords, and wires for voltages up to and including 450/750 V</i>
3.3 *	Wire connectors (for field wiring)	UL 486A <i>Wire Connectors and Soldering Lugs for Use With Copper Conductors</i> UL 486B <i>Wire Connectors for Use With Aluminum Conductors</i> UL 486E <i>Equipment Wiring Terminals for Use with Aluminum and/or Copper Conductors</i>	CSA C22.2 No. 65 <i>Wire Connectors</i> CSA C22.2 No. 153 <i>Quick-Connect Terminals</i>	
t3.4 *	Industrial control equipment	UL 508 <i>Industrial Control Equipment</i>	CSA C22.2 No. 14 <i>Industrial Control Equipment</i>	

Annex P.1 Continued

DC

Sub-clause from this standard	Component type	UL standard	CSA standard	IEC publication (shall be replaced by UL and/or CSA Standard)
3.4, 2.8.7 *	Switches	UL 20 <i>General-Use Snap Switches</i> UL 917 <i>Clock-Operated Switches</i> UL 1054 <i>Special-Use Switches</i>	CSA C22.2 No. 55 <i>Special Use Switches</i> CSA C22.2 No. 111 <i>General Use Switches</i> CAN/CSA C22.2 No. 177 <i>Clock-Operated Switches</i>	
4.2 *	Enclosures for electrical equipment	UL 50 <i>Enclosures for Electrical Equipment</i>	CAN/CSA C22.2 No. 94 <i>Special Purpose Enclosures</i>	
4.2.8 *	Cathode ray tubes	UL 1418 <i>Cathode-Ray Tubes</i>	CAN/CSA C22.2 No. 228 <i>Cathode Ray Tubes</i>	IEC 65: 1985 <i>Safety requirements for mains operated electronic and related apparatus for household and similar general use</i>
4.3.6, 3.2.5 *	Direct plug-in units	UL 1310 <i>Class 2 Power Units (Mechanical Assembly Requirements Only)</i>	CAN/CSA C22.2 No. 223 <i>Power Supplies With Extra-Low Voltage Class 2 Outputs (Mechanical Assembly Requirements Only)</i>	
4.7.3.2 *	Enclosure materials	UL 723 <i>Test for Surface Burning of Building Materials</i>	CAN/CSA C22.2 No. 0.17 <i>Evaluation of Properties of Polymeric Materials</i>	
5.3.7 *	Thermal cutoffs	UL 1020 <i>Thermal Cutoffs for Use in Electrical Appliances and Components</i>	CSA C22.2 No. 209 <i>Thermal Cut-Offs</i>	
5.3.7 *	Thermostats	UL 873 <i>Temperature-Indicating and -Regulating Equipment</i>	CSA C22.2 No. 24 <i>Temperature-Indicating and -Regulating Equipment</i>	
6.4 *	Communication circuits	UL 497 <i>Protectors for Paired Conductor Communication Circuits</i> UL 497A <i>Secondary Protectors for Communication Circuits</i> UL 497B <i>Protectors for Data Communication and Fire Alarm Circuits</i> UL 1863 <i>Communication Circuit Accessories</i>	CAN/CSA C22.2 No. 182.4 <i>Plugs, Receptacles, and Connectors for Communication Systems</i> CAN/CSA C22.2 No. 226 <i>Protectors in Telecommunication Networks</i> CAN/CSA C22.2 No. 233 <i>Cords and Cord Sets for Communication Systems</i>	
Annex T, 1.1.2	Enclosures for electrical equipment	See 1.1.2		
Annex U, 2.10.5.4	Insulated transformer winding wiring	See 2.10.5.4		
* Indicates UL, CSA or both standards having requirements providing equivalent levels of safety within the meaning of this standard. Requirements of either UL or CSA standard may be used.				
** Standards are equivalent except under conditions specified in parentheses in the table.				

P.2 UL and CSA Component Requirements (alternative)

DC

Annex P.2

DC

NOTE 1 – The complete text of Annex P.2 is a DC deviation.

DC

NOTE 2 – Please note that underlining to indicate text added to IEC 60950 is not used in this portion of annex P.

DC

All IEC component standard requirements in this standard are replaced by the relevant requirements of CSA and UL component standards as listed in this annex.

DC
DC

Products which are determined to comply with clauses 1 – 6 and applicable annexes of this standard are considered to comply with UL and CSA requirements except that components may require additional evaluation to determine compliance with IEC 60950 requirements.

DC
DC
DC

Any undated reference to a code or standard appearing in the requirements of this standard shall be interpreted as referring to the latest edition of that code or standard.

DC
DC

If no standard is listed, requirements are assumed to be those in IEC 60950.

DC

In the U.S. and Canada, any of the following components which comply with either the specified UL or CSA standards are considered as an acceptable alternative to the referenced IEC component standard and comply with the requirements of this standard.

DC
DC
DC**Annex P.2**

DC

Sub-clause from this standard	Component type	UL standard	CSA standard	IEC publication (may be replaced by UL or CSA Standard)
1.5.2 †	Battery chargers	UL 1236 <i>Battery Chargers for Charging Engine-Starter Batteries</i>	CAN/CSA C22.2 No. 107.2 <i>Battery Chargers</i>	
1.5.2	EMI filters	UL 1283 <i>Electromagnetic Interference Filters</i>	CSA C22.2 No. 8 <i>Electromagnetic Interference (EMI) Filters</i>	
1.5.2	Motor construction	UL 1004 <i>Electric Motors</i> UL 507 <i>Electric Fans</i>	CSA C22.2 No. 100 <i>Motors and Generators</i> CSA C22.2 No. 113 <i>Fans and Ventilators</i>	
1.5.2 †	Power supplies	UL 1950 <i>Safety of Information Technology Equipment, Including Electrical Business Equipment</i> , – without Supplement – (D3) considerations (first or subsequent editions) [To be deleted on April 1, 2005] UL 1310 <i>Class 2 Power Units</i>	CAN/CSA C22.2 No. 234 <i>Safety of Component Power Supplies</i> [To be deleted on April 1, 2005] or CAN/CSA C22.2 No. 950 <i>Safety of Information Technology Equipment, Including Electrical Business Equipment</i> (second or subsequent editions) [To be deleted on April 1, 2005] CAN/CSA C22.2 No. 223 <i>Power Supplies with Extra-Low Voltage Class 2 Outputs</i> (Direct plug-ins, with a mounting tab, are not acceptable)	

Annex P.2 Continued

DC

Sub-clause from this standard	Component type	UL standard	CSA standard	IEC publication (may be replaced by UL or CSA Standard)
1.5.2	Optical isolators	UL 1577 <i>Optical Isolators</i>	CSA Certification Notice, Component Acceptance Service No. 5 (Announcement of Extension of the Component Acceptance Service for Optocouplers and Related Devices)	
1.5.4, 4.3.6, 5.3.3	Transformers	UL 1585 <i>Class 2 and Class 3 Transformers</i>	CSA C22.2 No. 66 <i>Specialty Transformers</i>	
1.5.6, 1.5.7.1	Double-protection capacitors	UL 1414 <i>Across-the-Line, Antenna-Coupling, and Line-by-Pass Capacitors for Radio- and Television-Type Appliances</i>	CSA C22.2 No. 1 <i>Audio, Video and Similar Electronic Equipment</i>	IEC 60384-14: 1993 <i>Fixed capacitors for use in electronic equipment. Part 14: sectional specification: Fixed capacitors for radio interference suppression. Selection of methods of test and general requirements.</i>
1.7.13	Marking and labeling	UL 969 <i>Marking and Labeling Systems</i>	CSA C22.2 No. 0.15 <i>Adhesive Labels</i>	
2.5, 6.3	PTC	UL (Subject 1434) UL 8730-1 <i>Electrical Controls for Household and Similar Use; Part 1: General Requirements</i>	TIL No. CA-3	IEC 730-1 <i>Automatic electrical controls for household and similar use. Part 1: general requirements</i>
2.7	Fuses (supplementary applications)	UL 248-14 <i>Low-Voltage Fuses – Part 14: Supplemental Fuses</i> UL 1417 <i>Special Fuses for Radio- and Television-Type Appliances</i>	CSA C22.2 No. 248.14 <i>Part 14: Supplemental Fuses</i>	IEC 127-1 <i>Miniature fuses. Part 1: definitions for miniature fuses and general requirements for miniature fuse-links</i>
2.7	Fusing resistors	UL 1412 <i>Fusing Resistors and Temperature-Limited Resistors for Radio- and Television-Type Appliances</i> UL 8730-1 <i>Electrical Controls for Household and Similar Use; Part 1: General Requirements</i>	CSA C22.2 No. 1 <i>Audio, Video and Similar Electronic Equipment</i>	IEC 730-1 <i>Automatic electrical controls for household and similar use. Part 1: general requirements</i>

Annex P.2 Continued

DC

Sub-clause from this standard	Component type	UL standard	CSA standard	IEC publication (may be replaced by UL or CSA Standard)
2.9.1	Insulating materials	<p>UL 746C <i>Polymeric Materials – Use in Electrical Equipment Evaluations</i> (Sections 8 and 9) The following materials are considered acceptable for the support of uninsulated live parts: slate, porcelain, phenolic, or cold-molded composition, unfilled polycarbonate, unfilled nylon, nylon filled with inorganic compounds, melamine, melamine-phenolic, urea formaldehyde, or other material acceptable for the support of parts that are judged to comply with the Standard for Polymeric Materials – Use in Electrical Equipment Evaluations, UL 746C. These materials should withstand the most severe conditions likely to be met in service.</p> <ul style="list-style-type: none"> – A material need not comply with the requirements in UL 746C if it meets the insulation requirements applicable to the component. – Laminate material in printed wiring boards need not comply with the requirements in UL 746C. – Vulcanized fiber may be used for insulating bushings, washers, separators, and barriers, but not as the sole support for uninsulated live parts if shrinkage, current leakage, or warpage can result in a risk of fire, electric shock, injury to persons, or electrical energy – high current levels. 	<p>CSA 0.17-92 <i>Evaluation of Properties of Polymeric Materials</i> The following materials are considered acceptable for the support of uninsulated live parts: slate, porcelain, phenolic, or cold-molded composition, unfilled polycarbonate, unfilled nylon, nylon filled with inorganic compounds, melamine, melamine-phenolic, or other material acceptable for the support of parts that are judged to comply with the standard for polymeric materials – Evaluation of Properties of Polymeric Materials, CSA 0.17-92. These materials should withstand the most severe conditions likely to be met in service.</p> <ul style="list-style-type: none"> – A material need not comply with the requirements in CSA 0.17-92 if it meets the insulation requirements applicable to the component. – Laminate material in printed wiring boards need not comply with the requirements in CSA 0.17-92. – Vulcanized fiber may be used for insulating bushings, washers, separators, and barriers, but not as the sole support for uninsulated live parts if shrinkage, current leakage, or warpage can result in a risk of fire, electric shock, injury to persons, or electrical energy – high current levels. 	

Annex P.2 Continued

DC

Sub-clause from this standard	Component type	UL standard	CSA standard	IEC publication (may be replaced by UL or CSA Standard)
2.9.1, 4.5.1 †	Insulating systems	UL 1446 <i>Systems of Insulating Materials B General</i>	CAN/CSA C22.2 No.0 <i>General requirements B Canadian Electrical Code, Part II</i>	IEC 85 <i>Thermal evaluation and classification of electrical insulation</i>
2.9.5, 2.10.6, Annex R	Conformal coatings	UL 746C	CSA Electrical Bulletin 1402C	
3.2	Outlet boxes	UL 514A <i>Metallic Outlet Boxes</i> ; or UL 514B <i>Fittings for Conduit and Outlet Boxes</i> ; or UL 514C <i>Nonmetallic Outlet Boxes, Flush-Device Boxes, and Covers</i>	CAN/CSA C22.2 No. 18 <i>Outlet Boxes, Conduit Boxes, Fittings and Associated Hardware</i> ; or CAN/CSA C22.2 No. 85 <i>Rigid PVC Boxes and Fittings</i>	
3.3 †	Terminal blocks	UL 1059 <i>Terminal Blocks</i>	CSA C22.2 No. 158 <i>Terminal Blocks</i>	
4.3.4	Wire connectors	UL 486A <i>Wire Connectors and Soldering Lugs for Use With Copper Conductors</i> UL 486B <i>Wire Connectors for Use With Aluminum Conductors</i> UL 486C <i>Splicing Wire Connectors</i> UL 486E <i>Equipment Wiring Terminals for Use with Aluminum and/or Copper Conductors</i>	CSA C22.2 No. 65 <i>Wire Connectors</i>	
4.3.6, 1.5.4, 5.3.3	Transformers	See 1.5.4		
4.3.12	Flammability of liquids	UL 340 <i>Tests for Comparative Flammability of Liquids</i>		
4.5.1	Insulating systems	See 2.9.1		
4.6.5	Adhesives	UL 746C <i>Polymeric Materials – Use in Electrical Equipment Evaluations</i>	CAN/CSA C22.2 No. 0.17 <i>Evaluation of Properties of Polymeric Materials</i>	

Annex P.2 Continued

DC

Sub-clause from this standard	Component type	UL standard	CSA standard	IEC publication (may be replaced by UL or CSA Standard)
4.7 †	Polymeric materials	UL 746A <i>Polymeric Materials – Short Term Property Evaluations</i> ; or UL 746B <i>Polymeric Materials – Long Term Property Evaluations</i> ; or UL 746C <i>Polymeric Materials – Use in Electrical Equipment Evaluations</i> ; or UL 746D <i>Polymeric Materials – Fabricated Parts</i>	CAN/CSA C22.2 No. 0.17 <i>Evaluation of Properties of Polymeric Materials</i>	
4.7, 4.7.3 †	Flammability of plastic materials	UL 94 <i>Tests for Flammability of Plastic Materials for Parts in Devices and Appliances</i>	CAN/CSA C22.2 No. 0.17 <i>Evaluation of Properties of Polymeric Materials</i>	
4.7.3.1	Glow Wire Test	UL 746A <i>Polymeric Materials – Short Term Property Evaluations</i>	CAN/CSA C22.2 No. 0.17 <i>Evaluation of Properties of Polymeric Materials</i>	IEC 60695-1-1/1 <i>Fire Hazard Testing Part 1: Guidance for Assessing Fire Hazard of Electrotechnical Products – Section 1: General Guidance</i>
4.7.3.5	Air filter units	UL 900 <i>Test Performance of Air Filter Units</i>		
4.7.3.6	High-voltage components	UL 1413 <i>High-Voltage Components for Television-Type Appliances</i>	CSA C22.2 No. 1 <i>Audio, Video and Similar Electronic Equipment</i>	
5.3.3, 1.5.4, 4.3.6	Transformers	See 1.5.4		
6.3, 2.5	PTC	See 2.5		
A.2	Small plastic materials flame tests	UL 1694 <i>Tests for Flammability of Small Component Materials</i>	CAN/CSA C22.2 No. 0.17 <i>Evaluation of Properties of Polymeric Materials, Appendix C</i>	IEC 60695-2-2 <i>Fire Hazard Testing – Part 2: Test Methods – Section 2: Needle Flame Test</i>
A.6 †	Plastic materials V-0, V-1, V-2	UL 94 <i>Tests for Flammability of Plastic Materials for Parts in Devices and Appliances</i>	CAN/CSA C22.2 No. 0.17 <i>Evaluation of Properties of Polymeric Materials</i>	
A.7 †	Plastic materials HF-1, HF-2, HB-F	UL 94 <i>Tests for Flammability of Plastic Materials for Parts in Devices and Appliances</i>	CAN/CSA C22.2 No. 0.17 <i>Evaluation of Properties of Polymeric Materials</i>	
A.8 †	Plastic materials HB	UL 94 <i>Tests for Flammability of Plastic Materials for Parts in Devices and Appliances</i>	CAN/CSA C22.2 No. 0.17 <i>Evaluation of Properties of Polymeric Materials</i>	

Annex P.2 Continued

DC

Sub-clause from this standard	Component type	UL standard	CSA standard	IEC publication (may be replaced by UL or CSA Standard)
A.9 †	Plastic materials 5V	UL 94 <i>Tests for Flammability of Plastic Materials for Parts in Devices and Appliances</i>	CAN/CSA C22.2 No. 0.17 <i>Evaluation of Properties of Polymeric Materials</i>	
Annex B	Motor protection	UL 2111 <i>Overheating Protection of Motors</i>	CSA C22.2 No. 77 <i>Motors with Inherent Overheating Protection</i> ; or CSA C22.2 No. 100 <i>Motors and Generators</i>	
Annex R, 2.9.5, 2.10.6	Conformal coatings	See 2.9.5		

† Indicates CSA or UL standard having requirements that meet or exceed the relevant IEC requirements.

DC

Annex Q
(Informative)
Bibliography

IEC 60083:1997, *Plugs and socket-outlets for domestic and similar general use standardized in member countries of IEC*

IEC 60127 (all parts), *Miniature fuses*

IEC 60269-2-1:1996 *Low voltage fuses – Part 1: Supplementary requirements for fuses for use by authorised persons (fuses mainly for industrial application) – Sections I to V: Examples of types of standardised fuses for use by authorised persons*

IEC 60364-7-707: 1984, *Electrical installations of buildings – Part 7: Requirements for special installations or locations – Section 707: Earthing requirements for the installation of data processing equipment*

IEC 60410: 1973, *Sampling plans and procedures for inspection by attributes*

IEC 60479-1: 1994, *Effects of current on human beings and livestock – Part 1: General aspects*

IEC 60529: 1989, *Degrees of protection provided by enclosures (IP Code)*

IEC 60644-4: 1997, *Insulation coordination for equipment within low voltage systems – Part 4: Considerations of high-frequency voltage stress*

IEC 61032: 1997, *Test probes to verify protection by enclosures*

IEC 61140: 1997, *Protection against electric shock – Common aspects for installation and equipment*

ISO 2859-1: 1989, *Sampling procedures for inspection by attributes – Part 1: Sampling plans indexed by acceptance quality level (AQL)*

CFR 47, Part 68: *Code of Federal Regulations (USA) Part 68: Connection of terminal equipment to the telephone network (commonly referred to as "FCC Rules, part 68")*

ICRP 15: 1969, *Protection against ionizing radiations from external sources, published for the International Commission on Radiological Protection by Pergamon Press*

ITU-T Recommendation K.11: 1993, *Principles of protection against overvoltages and overcurrents*

Annex R
(Informative)
Examples of requirements for quality control programmes

NOTE – This annex gives examples of requirements for quality control programmes as specified in 2.10.6 for minimum separation distances for coated printed boards and in 2.10.3 and G.2 for reduced CLEARANCES.

R.1 Minimum separation distances for unpopulated coated printed boards (see 2.10.6)

A manufacturer wishing to use the reduced spacing separation distances permitted by 2.10.6, table 2N, shall implement a quality control programme for those features of the boards which are listed in table R.1. This programme shall include specific quality controls for the tools and materials which affect conductor spacing, adequate inspection of pattern and spacing, cleanliness, coating thickness, electrical tests for short circuits, insulation resistance and electric withstand voltage.

DE

The manufacturer shall also identify and plan the protection and, where applicable, installation processes which directly affect quality and shall ensure that these processes are carried out under controlled conditions. Controlled conditions shall include the following:

- documented work instructions defining process, equipment, environment and manner of production where the absence of such instructions would adversely affect quality, use of suitable production and installation equipment, suitable working environment, compliance with reference standards, specifications and quality plans;
- monitoring and control of suitable processes and product characteristics during production and installation in the equipment;
- criteria for workmanship stipulated to the extent necessary in written specifications or by means of representative samples;
- records maintained for qualified processes, equipment and personnel as appropriate.

Table R.1 provides the sampling plan for attributes and tests necessary to conform to the requirements of 2.10.6. The number of samples of production boards shall be based on IEC 60410 or ISO 2859-1 or equivalent national standards.

Table R.1
Rules for sampling and inspection — coated printed boards

Tests	BASIC INSULATION	SUPPLEMENTARY INSULATION	REINFORCED INSULATION
Spacing mm ¹⁾	Sampling S2 AQL 1,0	Sampling S2 AQL 1,0	Sampling S2 AQL 1,0
Electric strength test ⁴⁾	Sampling S2 AQL 2,5	Sampling S2 AQL 2,5	ROUTINE TEST; one failure requires evaluation for cause
Abrasion resistance	Sampling S1 AQL 2,5	Sampling S1 AQL 2,5	Sampling S1 AQL 2,5
Thermal ageing ²⁾	Sampling S3 AQL 4	Sampling S3 AQL 4	Sampling S3 AQL 4
Thermal cycling ²⁾	Sampling S1 AQL 1,5	Sampling S1 AQL 1,5	Sampling S1 AQL 1,5
Insulation resistance ³⁾	Sampling S2 AQL 2,5	Sampling S2 AQL 2,5	Sampling S2 AQL 2,5
Visual inspection of coating ⁵⁾	ROUTINE TEST	ROUTINE TEST	ROUTINE TEST

1) To minimize test and inspection time, it is permitted to replace measurement of spacings separation distances by measurement of breakdown voltage. Initially the breakdown voltage is established for 10 uncoated boards for which the correct spacing measurements have been confirmed. The breakdown voltage of subsequent uncoated production boards is then checked against a lower limit equal to the minimum breakdown voltage for the 10 initial boards minus 100 V. If breakdown occurs at this lower limit, a board is considered a failure unless direct measurement of the spacing conforms with the requirement.

2) The thermal ageing and thermal cycling tests shall be done whenever the type of coating material, printed board material, or the process is changed. It is recommended that it should be done at least once a year.

3) The insulation resistance shall be not less than 1 000 MΩ.

4) The electric strength test shall consist of one of the following alternatives:

- six impulses of alternating polarity, using a 1,2/50 μs impulse with a magnitude equal to the peak of the test voltage in table 5B (see 5.2.2);
- a three cycle pulse of a.c. power frequency with a magnitude equal to the test voltage in table 5B (see 5.2.2);
- six impulses of alternating polarity, using 10 ms d.c. impulses with a magnitude equal to the peak of the test voltage in table 5B (see 5.2.2).

5) Visual inspection without optical magnification or automated optical inspection with equivalent resolution shall show no cracks, no bubbles, no pinholes, or detachment of the coating in the area of reduced spacings. Any such defects shall be reason for rejection of the printed board.

DE

R.2 Reduced clearances (see 2.10.3)

A manufacturer wishing to use reduced CLEARANCES permitted by 2.10.3, tables 2H, 2J, 2K and G.2, shall implement a quality control programme for those features of the construction listed in table R.2. This programme shall include specific quality controls for the tools and materials which affect CLEARANCES.

The manufacturer shall also identify and plan the protection and, where applicable, installation processes which directly affect quality and shall ensure that these processes are carried out under controlled conditions. Controlled conditions shall include the following:

- documented work instructions defining process, equipment, environment, and manner of production where the absence of such instructions would adversely affect quality, suitable working environment, compliance with reference standards or specifications and quality plans;
- monitoring and control of suitable processes and product characteristics during production and installation in the equipment;
- criteria for workmanship stipulated to the extent necessary in written specifications or by means of representative samples;
- records maintained for qualified processes, equipment and personnel as appropriate.

Table R.2 provides the sampling plan for attributes and tests necessary to conform to the requirements of 2.10.3. The number of samples of production parts or assemblies shall be based on IEC 60410 or ISO 2859-1 or equivalent national standards.

**Table R.2
Rules for sampling and inspection – reduced clearances**

Tests	BASIC INSULATION	SUPPLEMENTARY INSULATION	REINFORCED INSULATION
CLEARANCE 1)	Sampling S2 AQL 4	Sampling S2 AQL 4	Sampling S2 AQL 4
Electric strength test 2)	No test	No test	ROUTINE TEST; one failure requires evaluation for cause
1) To minimise test and inspection time, it is permitted to replace measurement of CLEARANCES by measurement of breakdown voltage. Initially the breakdown voltage is established for 10 samples for which the correct CLEARANCE measurements have been confirmed. The breakdown voltage of subsequent parts or assemblies is then checked against a lower limit equal to the minimum breakdown voltage of the initial 10 samples minus 100 V. If breakdown occurs at this lower limit, a part or assembly is considered a failure unless direct measurement of the CLEARANCE conforms with the requirement.			

Table R.2 Continued

Tests	BASIC INSULATION	SUPPLEMENTARY INSULATION	REINFORCED INSULATION
<p>2) The electric strength test for REINFORCED INSULATION shall consist of one of the following alternatives:</p> <ul style="list-style-type: none">– six impulses of alternating polarity, using a 1,2/50 μs impulse with a magnitude equal to the peak of the test voltage in table 5B (see 5.2.2);– a three-cycle pulse of a.c. power frequency with a magnitude equal to the test voltage in table 5B (see 5.2.2);– six impulses of alternating polarity, using a 10 ms d.c. impulses with a magnitude equal to the peak of the test voltage in table 5B (see 5.2.2).			

Annex S
(informative)
Procedure for impulse testing
(see 6.2.2.3)

S.1 Test equipment

Impulse generator according to annex N.

Storage oscilloscope with a bandwidth of a few MHz.

High voltage probe with compensating elements.

S.2 Test procedure

Apply the required number of impulses to the equipment under test and record the waveform patterns.

Examples are given in clause S.3 to assist in judging whether or not a surge suppressor has operated or insulation has broken down.

S.3 Examples of waveforms during impulse testing

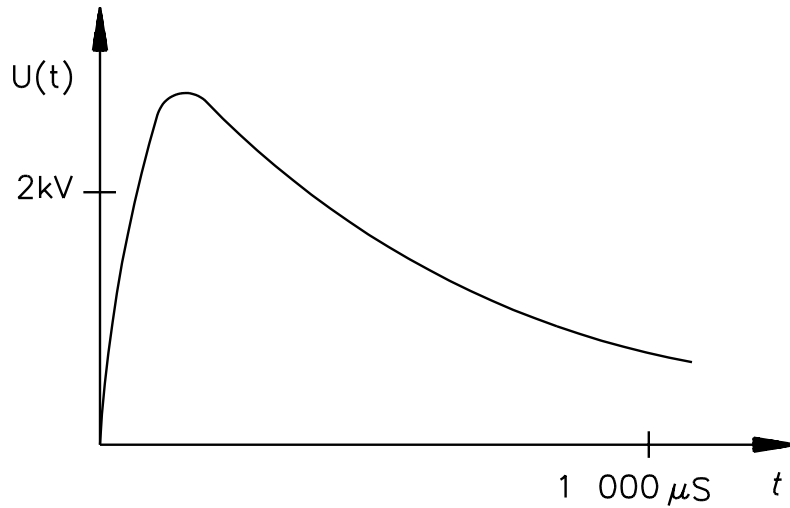

Consecutive impulses are identical in their waveforms.

SM438A

Figure S.1 – Waveform on insulation without surge suppressors and no breakdown

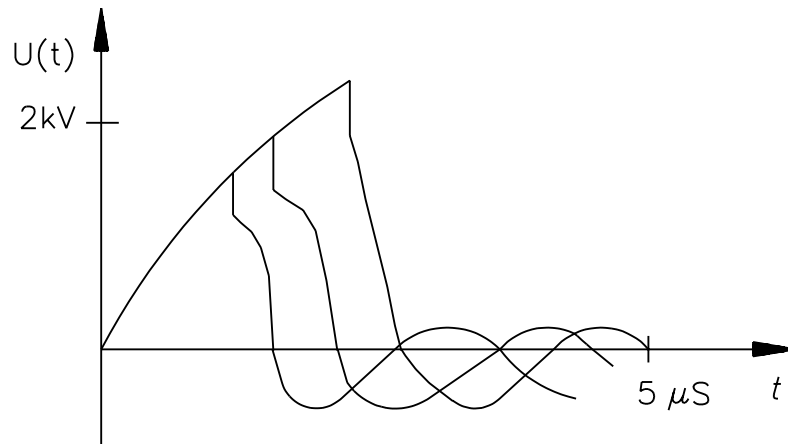

SM439A

Consecutive impulses are not identical in their waveforms. The pulse shape changes from pulse to pulse until a stable resistance path through the insulation is established. Breakdown can be seen clearly on the shape of the pulse voltage oscillogram.

Figure S.2 – Waveforms on insulation during breakdown without surge suppressors

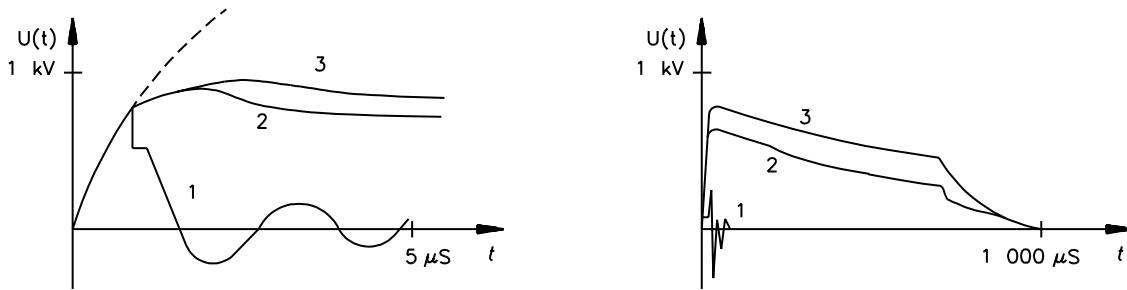

SM440A

1 – gas discharge type

2 – semiconductor type

3 – metal oxide type

Consecutive impulses are identical in their waveforms.

Figure S.3 – Waveforms on insulation with surge suppressors in operation

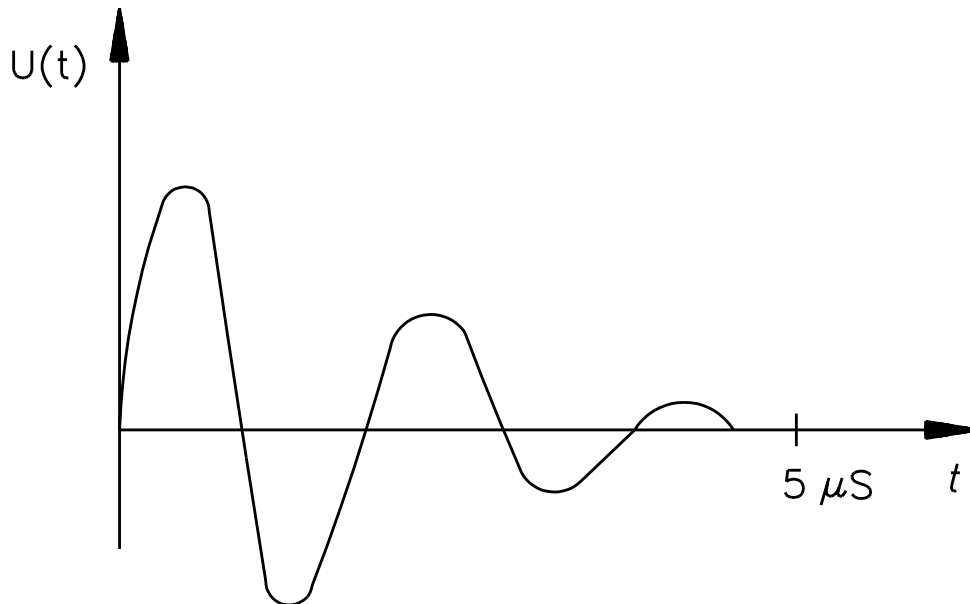

SM441A

Figure S.4 – Waveform on short-circuited surge suppressor and insulation

Annex T
(informative)
Guidance on protection against ingress of water
(see 1.1.2)

P

When the intended application is such that ingress of water is possible, an appropriate degree of protection other than IPXO should be selected by the manufacturer from IEC 60529: 1989, an extract from which is included in this annex.

Additional design features should then be included to ensure that ingress of water does not affect insulation.

IEC 60529: 1989 gives test conditions for each degree of protection other than IPXO. The conditions appropriate to the selected degree of protection should be applied to the equipment, immediately followed by an electric strength test as specified in 5.2.2 on any insulation which may have become wet, and inspection should show that water has not created a risk of personal injury or fire. In particular, there should be no trace of water on insulation that is not designed to operate when wet.

If the equipment is provided with drain holes, inspection should show that any water which enters does not accumulate and that it drains away without affecting compliance.

If the equipment is not provided with drain holes, account should be taken of the possibility of build-up of water.

Where equipment is only partly exposed to water, for example when it is to be installed through an opening in an outside wall, only the exposed parts should be subjected to the IEC 60529: 1989 test conditions. For these tests, such equipment should be installed in an appropriate test assembly, simulating actual conditions of installation according to the installation instructions, including the use of a kit of sealing parts where required.

It should not be possible to remove, without the aid of a TOOL, parts which ensure the required degree of protection against ingress of water.

The information in table T.1 is extracted from IEC 60529: 1989.

Table T.1
Extract from IEC 60529: 1989

Second characteristic numeral	Degree of protection	
	Brief description	Definition
0	Non-protected	—
1	Protected against vertically falling water drops	Vertically falling water drops shall have no harmful effects
2	Protected against vertically falling water drops when enclosure tilted up to 15°	Vertically falling drops shall have no harmful effects when the enclosure is tilted at any angle up to 15° on either side of the vertical
3	Protected against spraying water	Water sprayed at an angle up to 60° on either side of the vertical shall have no harmful effects
4	Protected against splashing water	Water splashed against the enclosure from any direction shall have no harmful effects
5	Protected against water jets	Water projected in jets against the enclosure from any direction shall have no harmful effects
6	Protected against powerful water jets	Water projected in powerful jets against the enclosure from any direction shall have no harmful effects
7	Protected against the effects of temporary immersion in water	Ingress of water in quantities causing harmful effects shall not be possible when the enclosure is temporarily immersed in water under standardized conditions of pressure and time
8	Protected against the effects of continuous immersion in water	Ingress of water in quantities causing harmful effects shall not be possible when the enclosure is continuously immersed in water under conditions which shall be agreed between manufacturer and user but which are more severe than for numeral 7

Annex U

(normative)

P**Insulated winding wires for use without interleaved insulation**
(see 2.10.5.4)

This annex specifies winding wire whose insulation may be used to provide BASIC, SUPPLEMENTARY, DOUBLE OR REINFORCED INSULATION in wound components without interleaved insulation.

This annex covers round winding wires having diameters between 0,2 mm and 1,00 mm. For other sizes, reference should be made to IEC 60851-3, IEC 60851-5 and IEC 60851-6.

U.1 Wire construction

If the wire is insulated with two or more spirally wrapped layers of tape, the overlap of layers shall be adequate to ensure continued overlap during manufacture of the wound component. The layers of spirally wrapped wire insulation shall be sufficiently secured to maintain the amount of overlap.

U.2 Type tests

The wire shall pass the tests of U.2.1 to U.2.4, carried out at a temperature between 15 °C and 35 °C and a relative humidity between 45 % and 75 %, unless specified otherwise.

U.2.1 Electric strength

The test sample is prepared according to IEC 60851-5:1996, 4.4.1 (for a twisted pair). The sample is then subjected to the test of 5.2.2 of this standard with a test voltage not less than twice the appropriate voltage in table 5B (see 5.2.2) of this standard or 6 000 V r.m.s., whichever is greater.

U.2.2 Flexibility and Adherence

Test 8 of IEC 60851-3:1996, 5.1.1, using the mandrel diameters of table U.1. The test sample is then examined in accordance with IEC 60851-3:1996, 5.1.1.4, followed by the test of 5.2.2 of this standard with a test voltage not less than the appropriate voltage in table 5B (see 5.2.2) of this standard or 3 000 V r.m.s., whichever is greater.

Table U.1 – Mandrel diameter

Nominal conductor diameter mm	Mandrel diameter mm ± 0,2 mm
0,20 – 0,34	4,0
0,35 – 0,49	6,0
0,50 – 0,74	8,0
0,75 – 1,00	10,0

The tension to be applied to the wire during winding on the mandrel is calculated from the wire diameter to be equivalent to 118 MPa ± 10 % (118 N/mm² ± 10 %).

U.2.3 Heat shock

Test 9 of IEC 60851-6:1996, followed by the electric strength test of 5.2.2 of this standard with a test voltage not less than the appropriate voltage in table 5B (see 5.2.2) of this standard or 3 000 V r.m.s., whichever is greater.

The oven temperature is the relevant temperature for the thermal class of insulation in table U.2.

The mandrel diameter and tension applied to the wire during winding on the mandrel are as in U.2.2.

The electric strength test is conducted at room temperature after removal from the oven.

Table U.2 – Oven temperature

Thermal class	A (105)	E (120)	B (130)	F (155)	H (180)
Oven temperature °C ± 5 °C	200	215	225	240	260

U.2.4 Retention of electric strength after bending

Five samples are prepared as in U.2.2 above and tested as follows. Each sample is removed from the mandrel, placed in a container and positioned so that it can be surrounded by at least 5 mm of metal shot. The ends of the conductor in the sample shall be sufficiently long to avoid flash over. The shot shall be not more than 2 mm in diameter and shall consist of balls of stainless steel, nickel or nickel plated iron. The shot is gently poured into the container until the sample under test is covered by at least 5 mm of shot. The shot shall be cleaned periodically with a suitable solvent (e.g. 1,1,1-trichloroethane).

NOTE – The above test procedure is reproduced from 4.6.1.c) of IEC 60851-5: 1998 (second edition including amendment 1), now withdrawn. It is not included in the third edition of that standard.

The test voltage is not less than the appropriate test voltage in table 5B (see 5.2.2) of this standard or 3 000 V r.m.s., whichever is greater. It is applied between the shot and the conductor.

The mandrel diameter and tension applied to the wire during winding on the mandrel are as in U.2.2.

U.3 Test during manufacture

The wire shall be subjected by the wire manufacturer to electric strength tests during manufacture as specified in U.3.1 and U.3.2.

U.3.1 Routine testing

The test voltage for ROUTINE TESTING shall be the appropriate voltage in table 5B (see 5.2.2) of this standard, with a minimum of 3 kV r.m.s. or 4,2 kV peak.

U.3.2 Sampling tests

Twisted pair samples shall be tested in accordance with IEC 60851-5:1996, 4.4.1. The minimum breakdown voltage shall be twice the appropriate voltage in table 5B (see 5.2.2) of this standard, but not less than 6 kV r.m.s. or 8,4 kV peak.

Annex V
(normative)
A.C. power distribution systems
(see 1.6.1)

V.1 Introduction

In IEC 60364-3, a.c. power distribution systems are classified TN, TT and IT, depending on the arrangement of current-carrying conductors and the method of earthing. The classes and codes are explained in this annex. Some examples of each class are given in the figures; other configurations also exist.

In the figures:

- in most cases, the power systems apply for single-phase and three-phase equipment, but for simplicity, only single-phase equipment is illustrated;
- the power sources may be transformer secondaries, motor-driven generators or uninterruptible power systems;
- for transformers within a user's building, some of the figures apply, and the building boundary represents a floor of the building;
- some power systems are earthed at additional points, for example, at the power entry points of users' buildings (see IEC 60364-4-41, 413.1.3.1, note 1).

The following types of equipment connection are taken into account; the numbers of wires mentioned do not include conductors used exclusively for earthing.

Single-phase, 2 wire

Single-phase, 3 wire

Two-phase, 3 wire

Three-phase, 3 wire

Three-phase, 4 wire

The system codes used have the following meaning:

- First letter: relationship of the power system to earth;

T means direct connection of one pole to earth.

I means system isolated from earth, or one point connected to earth through an impedance.

- Second letter: earthing of the equipment;

T means direct electrical connection of the equipment to earth, independently of the earthing of any point of the power system,

N means direct electrical connection of the equipment to the earthed point of the power system (in a.c. systems, the earthed point of the power system is normally the neutral point or, if a neutral point is not available, a phase conductor).

– Subsequent letters if any: arrangement of neutral and protective conductors;

S means the protective function is provided by a conductor separate from the neutral or from the earthed line (or in a.c. systems, earthed phase) conductor;

C means the neutral and protective functions are combined in a single conductor (PEN conductor).

V.2 TN power systems

TN power systems are directly earthed, the parts of the equipment required to be earthed being connected by PROTECTIVE EARTHING CONDUCTORS. Three types of TN power systems are considered:

- TN-S power system, in which a separate protective conductor is used through-out the system;
- TN-C-S power system, in which neutral and protective functions are combined in a single conductor in part of the system;
- TN-C power system, in which neutral and protective functions are combined in a single conductor throughout the system.

Some TN power systems are supplied from a secondary winding of a transformer that has an earthed centre tap (neutral). Where the two phase conductors and the neutral conductor are available, these systems are commonly known as "single-phase, 3-wire power systems".

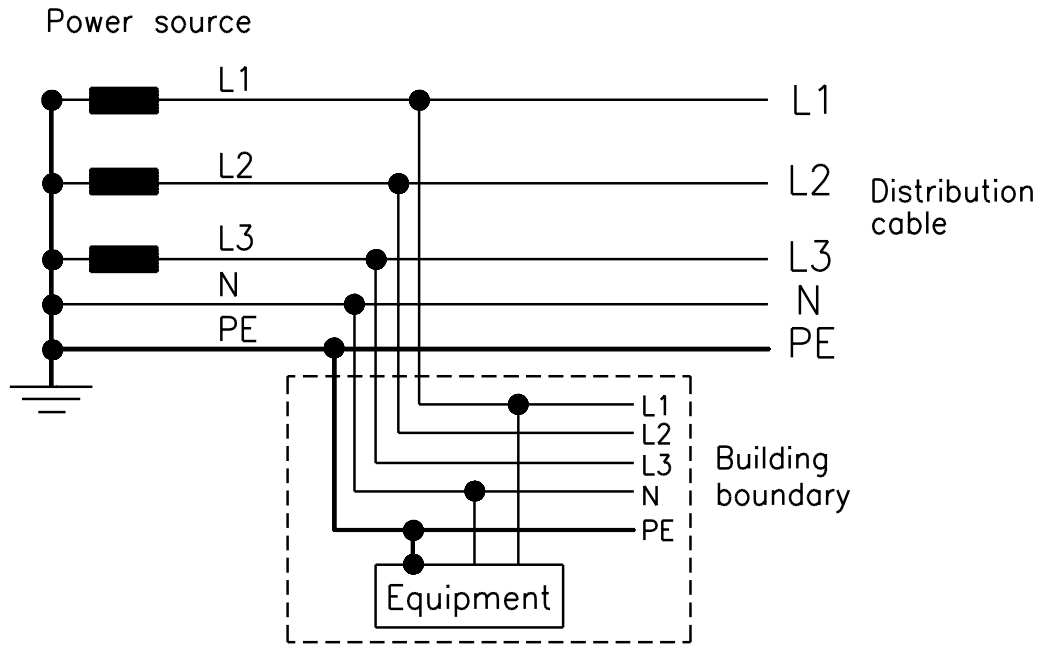

Separate neutral and protective conductors

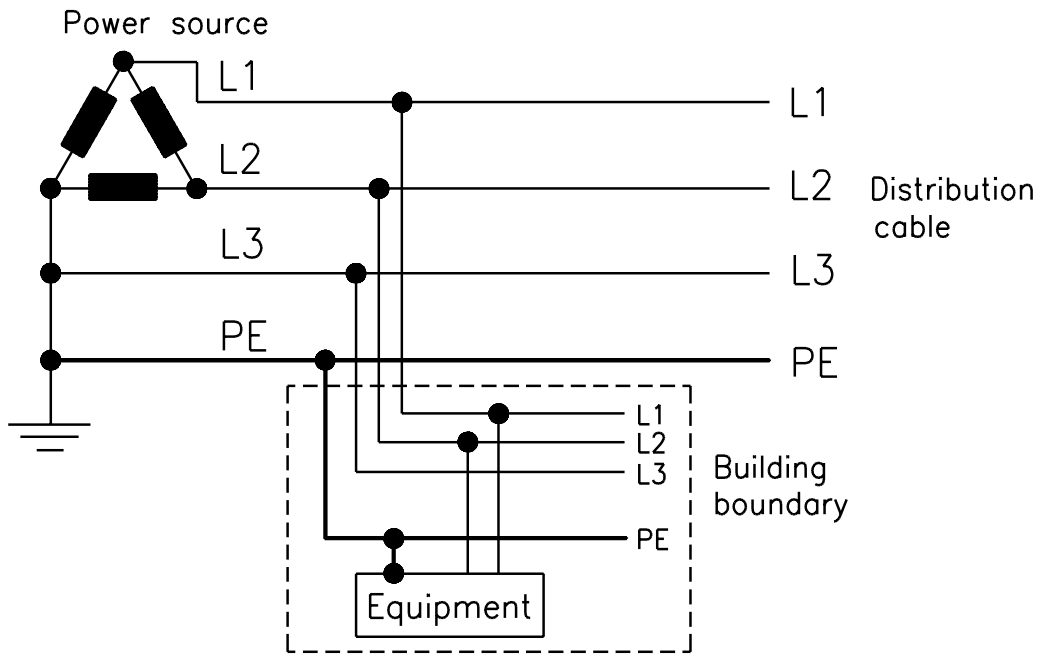

Earthed line conductor

S4095A

Figure V.1 – Examples of TN-S power systems

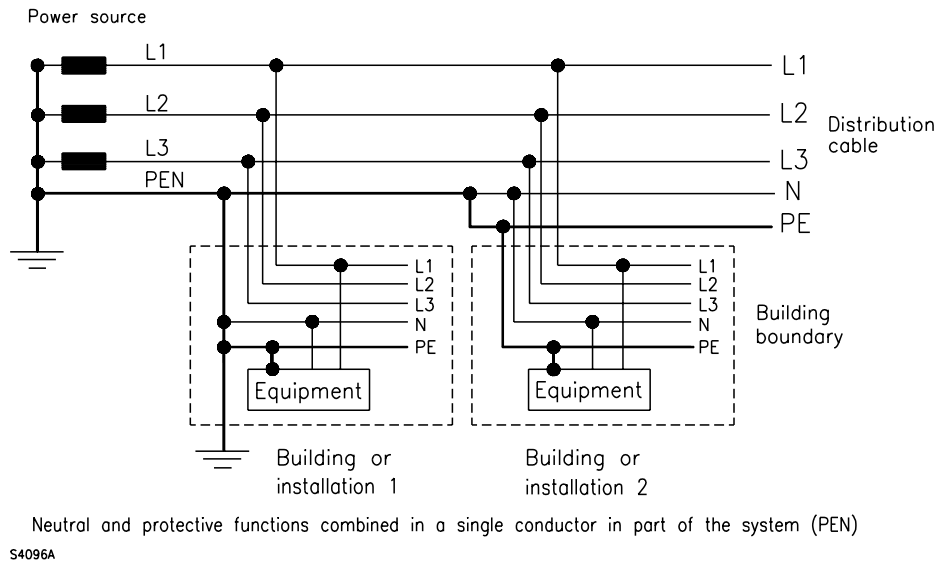

NOTE – The point at which the PEN conductor is separated into protective earth and neutral conductors may be at the building entrance or at distribution panels within the building.

Figure V.2 – Example of TN-C-S power system

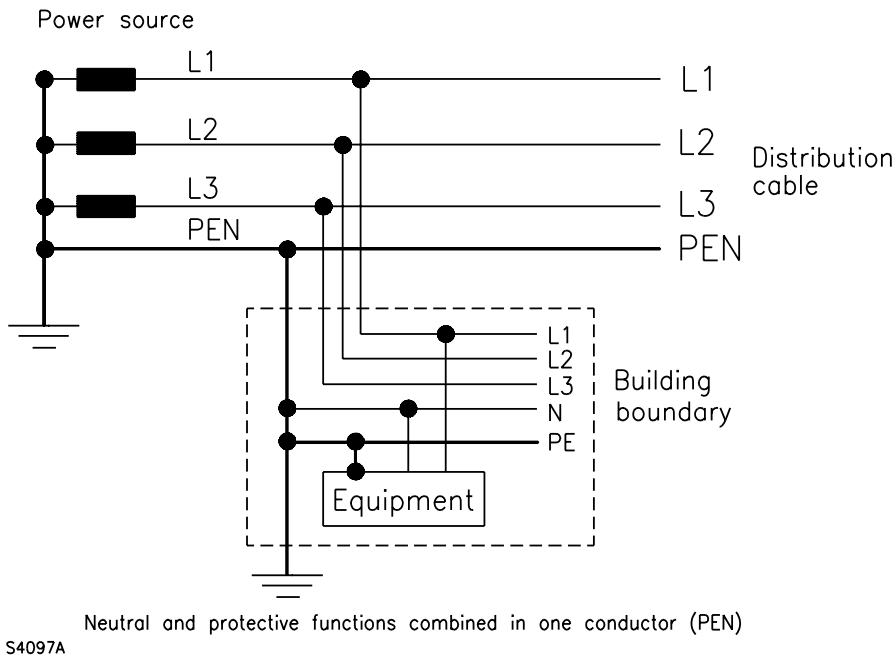
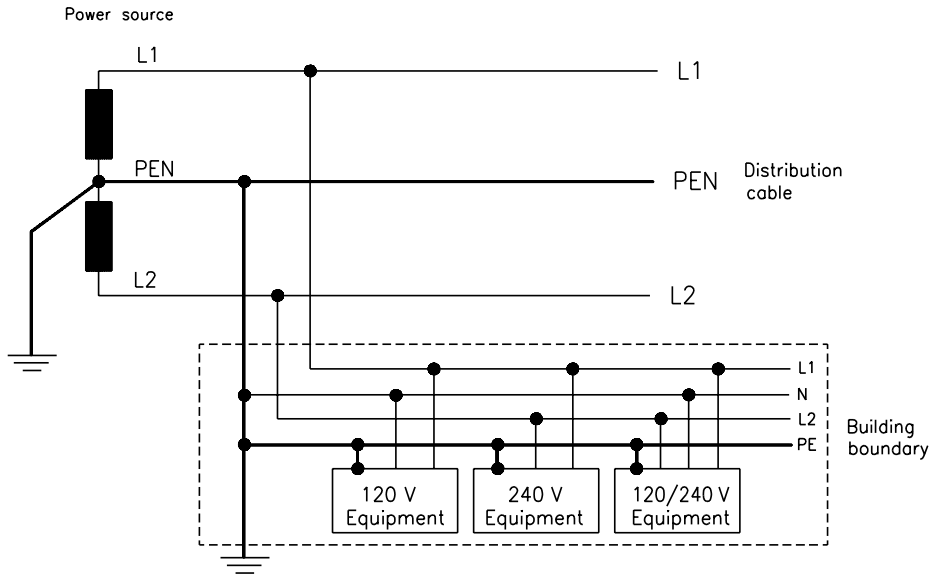

Figure V.3 – Example of TN-C power system



Protective and neutral functions combined in one conductor (PEN)
 This system is widely used in North America at 120/240 V.

S4098A

Figure V.4 – Example of single-phase, 3-wire TN-C power system

V.3 TT power systems

TT power systems have one point directly earthed, the parts of the equipment required to be earthed being connected at the user's premises to earth electrodes that are electrically independent of the earth electrodes of the power distribution system.

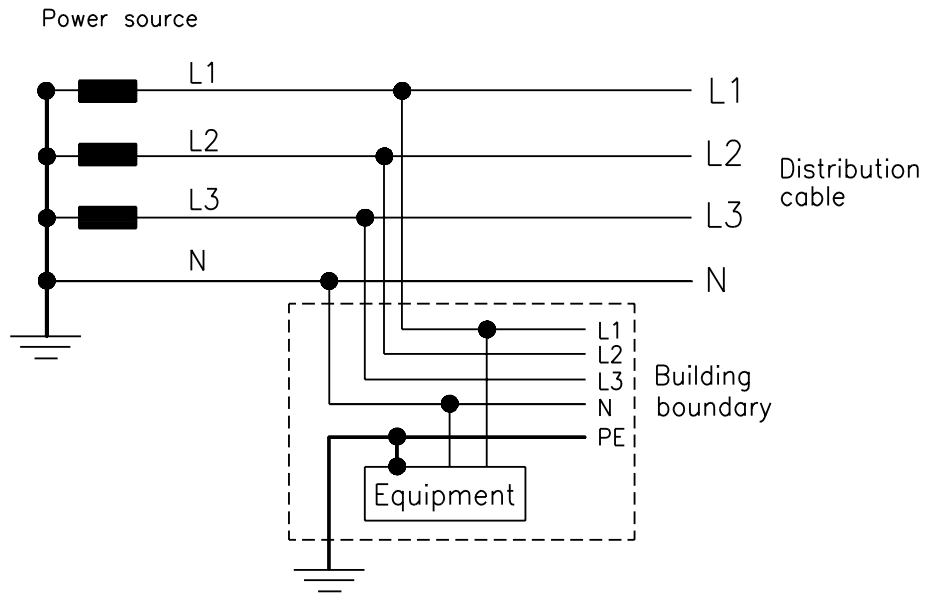

Earthed neutral and independent earthing of equipment

S4099A

Figure V.5 – Example of three line and neutral TT power system

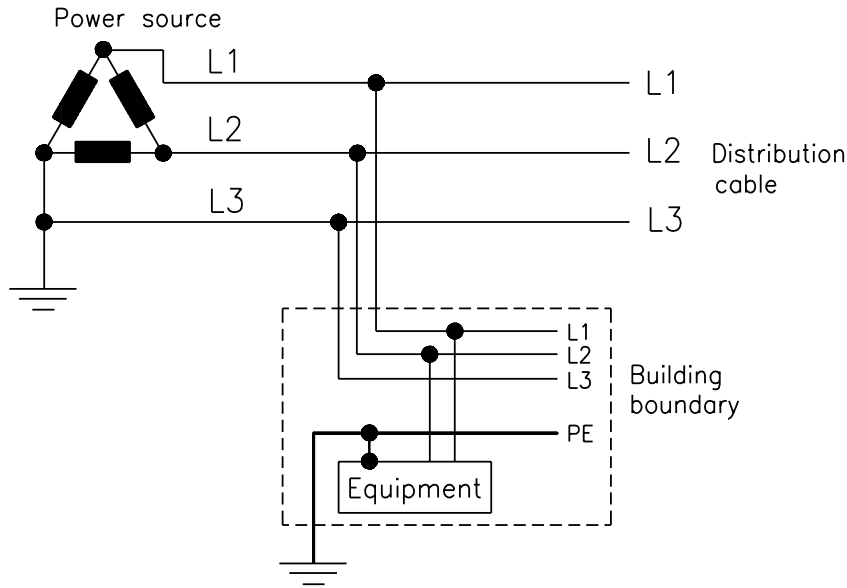

S4102A

Earthed line and independent earthing of equipment

Figure V.6 – Example of three line TT power system

V.4 IT power systems

IT power systems are isolated from earth, except that one point may be connected to earth through an impedance or a voltage limiter. The parts of the equipment required to be earthed are connected to earth electrodes at the user's premises.

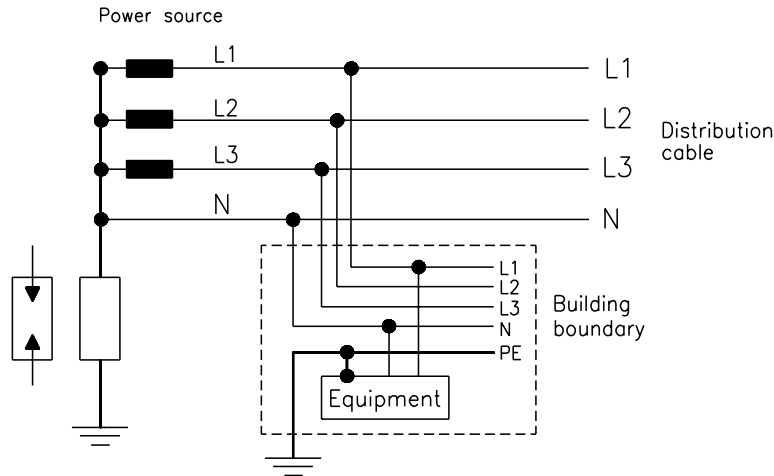

The neutral may be connected to earth through an impedance or voltage limiter, or isolated from earth

S4101A

This system is widely used isolated from earth, in some installations in France, with impedance to earth, at 230/400 V, and in Norway, with voltage limiter, neutral not distributed, at 230 V line-to-line.

Figure V.7 – Example of three line (and neutral) IT power system

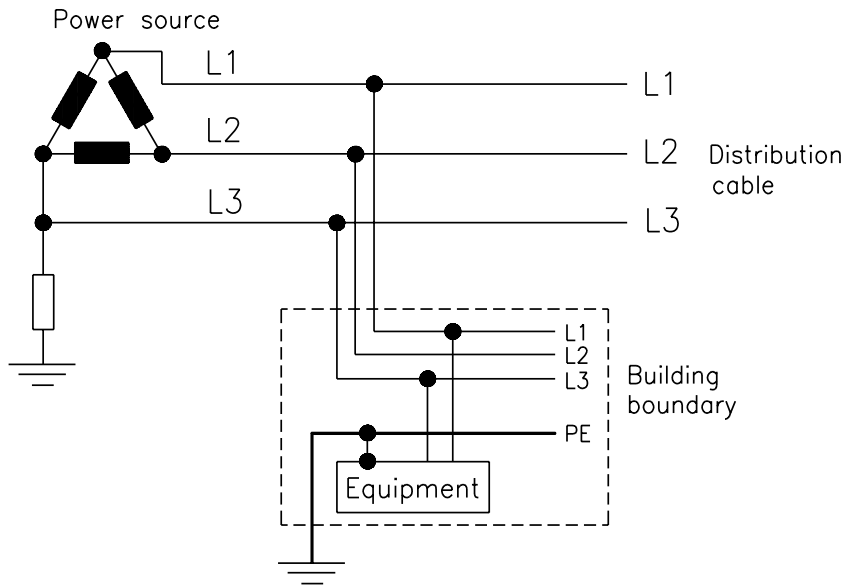

The system may be isolated from earth

S4100A

Figure V.8 – Example of three line IT power system

Annex W
(informative)
Summation of touch currents

This annex explains the background to the requirements and tests in 5.1.8.2.

W.1 Touch current from electronic circuits

There are two quite different mechanisms that determine the current through a human body that touches an electronic circuit (or power bus), depending on whether or not the circuit is earthed. This distinction between earthed and unearthed (floating) circuits is not the same as between CLASS I EQUIPMENT and CLASS II EQUIPMENT. Floating circuits can exist in CLASS I EQUIPMENT and earthed circuits in CLASS II EQUIPMENT. Floating circuits are commonly, but not exclusively, used in telecommunications equipment and earthed circuits in data processing equipment, also not exclusively.

In order to consider the worst case, it will be assumed in this annex that TELECOMMUNICATION NETWORKS are floating and that the A.C. MAINS SUPPLY and human bodies (SERVICE PERSONNEL OR OPERATORS) are earthed. It should be noted that SERVICE PERSONNEL can touch some parts that are not OPERATOR-accessible. An "earthed" circuit means that the circuit is either directly earthed or in some way referenced to earth so that its potential with respect to earth is fixed.

W.1.1 Floating circuits

If the circuit is not earthed, the current (I_C) through the human body is "leakage" through stray or added capacitance (C) across the insulation in the mains transformer (see figure W.1).

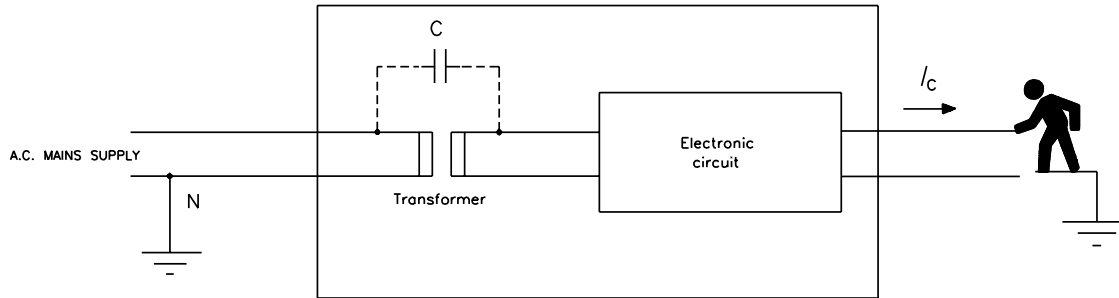

SM1381A

Figure W.1 – Touch current from a floating circuit

This current is coming from a relatively high voltage, high impedance source, and its value is largely unaffected by the operating voltage on the electronic circuit. In the standard, the body current (I_c) is limited by applying a test using the measuring instrument in annex D, which roughly simulates a human body.

W.1.2 Earthed circuits

If the electronic circuit is earthed, the current through the human body (I_v) is due to the operating voltage (V) of the circuit, which is a source of low impedance compared with the body (see figure W.2). Any leakage current from the mains transformer (see W.1.1), will be conducted to earth and will not pass through the body.

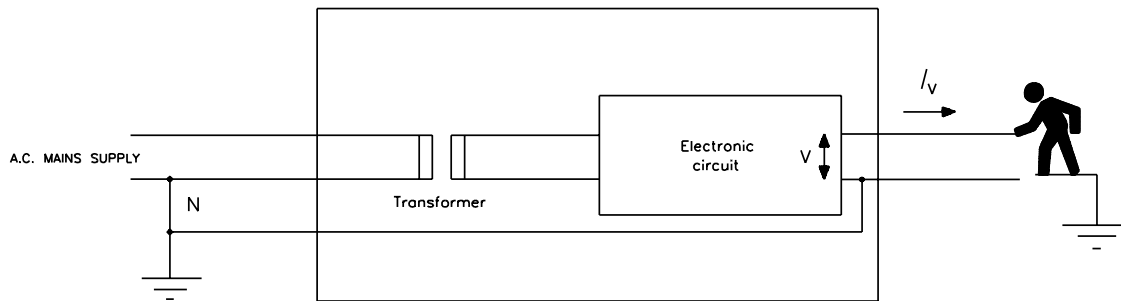

SM1382A

Figure W.2 – Touch current from an earthed circuit

In the standard, the body current (I_v) is limited by specifying maximum voltage values for the accessible circuit, which must be an SELV CIRCUIT or (with restricted accessibility) a TNV CIRCUIT.

W.2 Interconnection of several equipments

It is a characteristic of information technology equipment, especially in telecommunications applications, that many equipments may be connected to a single central equipment in a “star” topology. An example is telephone extensions or data terminals connected to a PABX, which may have tens or hundreds of ports. This example is used in the following description (see figure W.3).

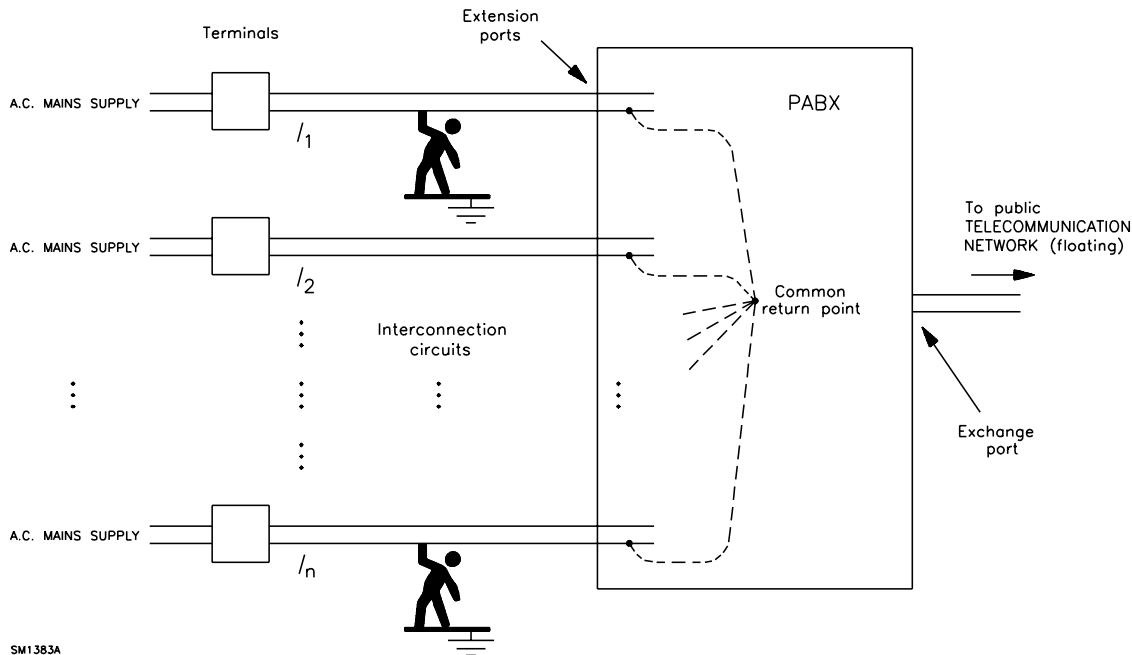

Figure W.3 – Summation of touch currents in a PABX

Each terminal equipment can deliver current to a human body touching the interconnecting circuit (I_1 , I_2 , etc.), added to any current coming from the PABX port circuitry. If several circuits are connected to a common point, their individual touch currents will add together, and this represents a possible risk to an earthed human body that touches the interconnection circuit.

Various ways of avoiding this risk are considered in the following subclauses.

W.2.1 Isolation

Isolate all interconnection circuits from each other and from earth, and limit I_1 , I_2 , etc., to a safe value as described in W.1.1 above. This implies either the use in the PABX of a separate power supply for each port, or the provision of an individual line (signal) transformer for each port. Such solutions may not be cost effective.

W.2.2 Common return, isolated from earth

Connect all interconnection circuits to a common return point that is isolated from earth. (Such connections to a common point may in any case be necessary for functional reasons.) In this case the total current from all interconnection circuits will pass through an earthed human body that touches either wire of any interconnection circuit. This current can only be limited by controlling the values $I_1, I_2 \dots I_n$ in relation to the number of ports on the PABX. However, the value of the total current will probably be less than $I_1 + I_2 + \dots + I_n$ due to harmonic and other effects.

W.2.3 Common return, connected to protective earth

Connect all interconnection circuits to a common return point and connect that point to protective earth. The situation described in W.1.2 above applies regardless of the number of ports. Since safety depends on the presence of the earth connection, it may be necessary to use high-integrity earthing arrangements, depending on the maximum value of the total current that could flow.

Annex X
(informative)
Maximum heating effect in transformer tests
(see C.1)

Subclause C.1 requires transformers to be loaded in such a way as to give the maximum heating effect. In this annex examples are given of various methods of producing this condition. Other methods are possible and compliance with C.1 is not restricted to these examples.

X.1 Determination of maximum input current

The value of the input current at rated load is established. This is I_r , see step A of table X.1. The value may be established by test or from manufacturer's data.

A load is applied to the output winding or to the output of the switch mode power supply unit while measuring the input current. The load is adjusted as quickly as possible to provide the maximum value of input current which can be sustained for approximately 10 s of operation. This is I_m , see step B of table X.1. The test is then repeated according to step C and, if necessary, steps D to J of table X.1. The input current at each step is then noted and maintained until either:

- a) the temperature of the transformer stabilizes without the operation of any component or protective device (inherent protection) in which case no further testing is conducted; or
- b) a component or protective device operates, in which case the winding temperature is noted immediately. The test of X.2 is then conducted depending on the type of protection.

If any component or protective device operates within 10 s after the application of the primary voltage, I_m is the value recorded just before the component or protective device operates.

In conducting the tests described in steps C to J of table X.1, the variable load is adjusted to the required value as quickly as possible, and readjusted if necessary, 1 min after application of the primary voltage. The sequence of steps C to J may be reversed.

Table X.1 – Test steps

Steps	Input current of the transformer or switch mode power supply unit
A	Input current at rated load = I_r
B	Maximum value of input current after 10 s of operation = I_m
C	$I_r + 0,75 (I_m - I_r)$
D	$I_r + 0,50 (I_m - I_r)$
E	$I_r + 0,25 (I_m - I_r)$
F	$I_r + 0,20 (I_m - I_r)$
G	$I_r + 0,15 (I_m - I_r)$
H	$I_r + 0,10 (I_m - I_r)$
J	$I_r + 0,05 (I_m - I_r)$

X.2 Overload test procedure*Electronic protection:*

If the test of X.1 results in condition X.1 b), the current is either reduced in steps of 5 % from this condition or increased in steps of 5 % from the rated load to find the maximum overload at which the temperature stabilizes without the operation of any electronic protection.

Thermal protection:

An overload is applied such that the operating temperature remains a few degrees below the rated opening temperature of the thermal protection.

Overcurrent protection:

An overload is applied such that a current flows in accordance with the current versus time trip curves of the overcurrent protective device.

Annex NAA
(normative)
Markings and instructions

D2
D2
D2

This annex identifies the markings and instructions required for Canada and the U.S. Excluding the words "WARNING" and "CAUTION" wording equivalent to that provided in this annex may be used.

D2
D2
D2

French translations of required markings are considered informative. It is the responsibility of the manufacturer to provide bilingual markings, where applicable, in accordance with local jurisdictional requirements.

D2
D2
D2

NOTE 1 – In Canada, there are two official languages, English and French. This annex lists acceptable French translations of the markings specified in this standard.

D2
D2

NOTE 2 – Underlining to indicate text added to IEC 60950 is not used in this annex.

D2

NOTE 3 – The complete text of Annex NAA is a deviation. The deviation types are noted in the margin or in the last column of the table.

D2

Other markings may be required.

D2

Annex NAA

Sub-clause reference from IEC 60950	Requirement	Example of English text for marking/instruction	Example of French text for marking/instruction	
1.1.1	Equipment intended for use exclusively outside of a computer room need not be subjected to computer room-based regulatory requirements if the equipment is marked, or provided with installation instructions, indicating that the equipment is not intended for use in a computer room as defined in the Standard for the Protection of Electronic Computer/Data Processing Equipment, ANSI/NFPA 75.	Not for use in a computer room as defined in the Standard for the Protection of Electronic Computer/Data Processing Equipment, ANSI/NFPA 75.	Ne peut être utilisé dans une salle d'ordinateurs telle que définie dans la norme ANSI/NFPA 75 Standard for Protection of Electronic Computer/Data Processing Equipment	D1

Annex NAA Continued

Sub-clause reference from IEC 60950	Requirement	Example of English text for marking/instruction	Example of French text for marking/instruction	
1.5.5	<p>Each detachable external interconnecting cable (with terminations), 3,05 m or less in length and furnished as part of the equipment, shall be marked or similarly identified in the installation instructions with the name, trademark or trade name of the organization that is responsible for the equipment and the organization's identifying number or equivalent designation for the cable. The marking may be applied on the cable at any location.</p> <p>This marking need not comply with the requirements in the Standard for Marking and Labeling Systems, UL 969, or Adhesive Labels, CSA C22.2 No. 0.15.</p> <p>This requirement does not apply to interconnecting cable types which are specified in the National Electrical Code or the Canadian Electrical Code.</p>			
1.5.5	The output connectors for other than limited power and TNV CIRCUITS shall be marked or otherwise described in installation instructions to identify the type of circuit, the intended cable type or the circuit relevant characteristics.	"DP-1" or "DP-2"	DP-1 ou DP-2	D2
1.7.1	See NAA.1 for guidance on information that may be provided to allow for the proper selection of a power supply.			D2

Table NAA.1 (informative)
Guidance to allow for proper selection of power supplies

D2
D2

<p>1. The following information may be provided.</p> <ul style="list-style-type: none"> a) rated output voltage(s); b) rated output current(s); c) rated output frequency or frequency range or symbol for d.c.; d) total maximum output power if it is less than the sum of the powers of the individual outputs; e) required rating and type of the overcurrent protection to be provided in the end product, if not provided as an integral part of the power supply; and f) output short circuit current(s). 	<p>2. One of the following classification levels may be provided.</p> <ul style="list-style-type: none"> a) LEVEL 0: Classification Level 0 (L0) for power supplies that require special additional features or that depend on the host equipment to meet the applicable requirements; b) LEVEL 1: Classification Level 1 (L1) for power supplies with output circuits that are either not suitable for, or have not been investigated for SELV CIRCUITS; c) LEVEL 2: Reserved for future use; d. LEVEL 3: Classification Level 3 (L3) for power supplies with output circuits that all meet the requirements for SELV CIRCUITS and that, under any condition of output overloading do not exceed 240 VA (i.e. the outputs are SELV CIRCUITS and at non-HAZARDOUS ENERGY LEVELS); e) LEVEL 4: Classification Level 4 (L4) for power supplies with outputs suitable for direct connection to the TELECOMMUNICATION NETWORK; NOTE 1 – The output is suitable for direct connection to the TELECOMMUNICATION NETWORK if the output current is limited to 1,3 A by inherent impedance or by an overcurrent protective device rated no more than 1 A (See 6.3). f) LEVEL 5: Classification Level 5 (L5) for power supplies having output circuits that meet the requirements for SELV CIRCUITS; g) LEVEL 6: Classification Level 6 (L6) to indicate a multiple output power supply having output circuits in any combination of Levels 1, 3, 4, and 5. 	<p>3. One of the following classifications may be provided.</p> <ul style="list-style-type: none"> a) Method 1: Classification M1 for power supplies using method 1 for isolation of SELV or TNV CIRCUITS from the PRIMARY CIRCUIT or HAZARDOUS VOLTAGE circuits; b) Method 2: Classification M2 for power supplies using method 2 for isolation of SELV or TNV CIRCUITS from the PRIMARY CIRCUIT or HAZARDOUS VOLTAGE circuits; c) Method 3: Classification M3 for power supplies using method 3 for isolation of SELV CIRCUITS from the PRIMARY CIRCUIT or HAZARDOUS VOLTAGE circuits; d) Method 4: Classification M4 to indicate a multiple output power supply having SELV or TNV CIRCUITS isolated from the PRIMARY CIRCUIT or HAZARDOUS VOLTAGE circuits in any combination of methods 1, 2, and 3. <p>NOTE – As an example, an output (of a power supply) designated as "L3M1" indicates the particular output:</p> <ul style="list-style-type: none"> a) is a SELV CIRCUIT; b) does not exceed 240 VA, under any condition of overloading; and c) is isolated from the PRIMARY CIRCUIT by DOUBLE or REINFORCED INSULATION).
--	---	--

Table NAA.1 (informative) Continued

D2

	<p>NOTE 2 – Additional markings are allowed, provided they do not give rise to misunderstanding.</p> <p>NOTE 3 – Conditions of acceptability, if any, should be provided in the installation instructions.</p>	
--	--	--

Annex NAA

Sub-clause reference from IEC 60950	Requirement	Example of English text for marking/instruction	Example of French text for marking/instruction	
1.7.4	See 1.7.4	See 1.7.4	VOIR LA NOTICE D'INSTALLATION AVANT DE RACCORDER AU RÉSEAU	DE
1.7.6	A marking shall be located adjacent to the fuse rating marking provided in operator-serviceable areas to identify the need for using the indicated fuse. The marking shall be located so that it is obvious as to which fuse or fuseholder the marking applies. A single marking is acceptable for a group of fuses.	CAUTION: For continued protection against risk of fire, replace only with same type and rating of fuse.	ATTENTION: Pour ne pas compromettre la protection contre les risques d'incendie, remplacer par un fusible de même type et de mêmes caractéristiques nominales.	D2
1.7.6	In an operator access area, there shall be indicated on or near each lampholder the maximum wattage, or lamp type number, or model designation.			D2
1.7.15	See 1.7.15	See 1.7.15	<p>ATTENTION</p> <p>Il y a danger d'explosion s'il y a remplacement incorrect de la batterie.</p> <p>Remplacer uniquement avec une batterie du même type ou d'un type équivalent recommandé par le constructeur.</p> <p>Mettre au rebut les batteries usagées conformément aux instructions du fabricant.</p>	DE
2.7.6	See 2.7.6	See 2.7.6	ATTENTION. Double pôle/fusible sur le neutre.	DE

Annex NAA Continued

Sub-clause reference from IEC 60950	Requirement	Example of English text for marking/instruction	Example of French text for marking/instruction	
3.2.3	<p>If the wires in a terminal box or compartment intended for power-supply connection of equipment can attain a temperature higher than 60°C during the normal-temperature test, the unit shall be marked as indicated in this annex. The marking shall be provided at or near the point at which the supply connections are to be made. The temperature to be used in the marking shall be 75°C if the temperature attained in the terminal box or compartment is 61 – 75°C, or 90°C if the temperature attained in the terminal box or compartment is 75 – 90°C.</p> <p>Refer to annex NAE for details regarding the regulatory requirements for supply connections.</p>	<p>For supply connections, use wires suitable for at least _____°C.</p>	<p>Utiliser des fils convenant à une température de _____°C pour les connexions d'alimentation.</p>	D2
3.3.6	<p>Equipment incorporating field wiring terminals intended to be connected to aluminum conductors shall be so identified for the connection of aluminum conductors. This marking shall be independent of all other markings on the terminal connectors and shall be visible after installation.</p> <p>The terminal for the connection of an equipment protective earthing (grounding) conductor shall not be identified for the connection of an aluminum conductor.</p>	<p>"Use Aluminum Conductors Only" or "Use Aluminum or Copper-Clad Aluminum Conductors Only" if the terminal is intended only for connection to aluminum wire.</p> <p>"Use Copper or Aluminum Conductors" or "Use Copper, Copper-Clad Aluminum, or Aluminum Conductors" if the terminal is intended for connection to both copper and aluminum wire.</p>	<p>" Utiliser seulement des conducteurs en aluminium " or " Utiliser seulement des conducteurs en aluminium cuivré " if the terminal is intended only for connection to aluminum wire.</p> <p>" Utiliser seulement des conducteurs en cuivre ou en aluminium " or " Utiliser des conducteurs en cuivre, en aluminium ou en aluminium cuivré " if the terminal is intended for connection to both copper and aluminum wire.</p>	D1
3.3.8	<p>Connectors and field-wiring terminals involving external Class 2 or Class 3 circuits shall be provided with a marking indicating the minimum class of the wiring that can be used. The marking shall be located adjacent to the terminals and shall be visible during wiring.</p>	<p>"Class 2" or "Class 2 Output."</p>	<p>" Classe 2" or " Sortie Classe 2 ".</p>	D1

Annex NAA Continued

Sub-clause reference from IEC 60950	Requirement	Example of English text for marking/instruction	Example of French text for marking/instruction	
3.6	Equipment that has the earthed conductor of a d.c. supply circuit connected to the earthing conductor at the equipment shall be provided with a permanent marking located near and in plain view of the field wiring terminals and worded as indicated. Alternatively, the wording can be replaced by the ⚠ symbol on the product if the specified wording appears in the installation instructions.	CAUTION: This equipment has a connection between the earthed conductor of the d.c. supply circuit and the earthing conductor. See installation instructions.	Cet appareil comporte une connexion entre le conducteur relié à la terre du circuit d'alimentation c.c. et son conducteur de terre.	D2
3.6	Equipment that has provisions to connect the earthed conductor of a d.c. supply circuit to the earthing conductor at the equipment shall be provided with a permanent marking located near and in plain view of the field wiring terminals and worded as indicated. Alternatively, the wording can be replaced by the ⚠ symbol on the product if the specified wording appears in the installation instructions.	CAUTION: This equipment is designed to permit the connection of the earthed conductor of the d.c. supply circuit to the earthing conductor at the equipment. See installation instructions.	Cet appareil est conçu pour permettre le raccordement du conducteur relié à la terre du circuit d'alimentation c.c. au conducteur de terre de l'appareil.	D2
3.6	If equipment has the earthed conductor of a d.c. supply circuit connected to the earthing conductor at the equipment, instructions shall include that all of the conditions in this annex must be met, where applicable.	<p>1) This equipment shall be connected directly to the d.c. supply system earthing electrode conductor or to a bonding jumper from an earthing terminal bar or bus to which the d.c. supply system earthing electrode is connected.</p> <p>2) This equipment shall be located in the same immediate area (such as, adjacent cabinets) as any other equipment that has a connection between the earthed conductor of the same d.c. supply circuit and the earthing conductor, and also the point of earthing of the d.c. system. The d.c. system shall not be earthed elsewhere.</p>	<p>Ce matériel doit être raccordé directement au conducteur de la prise de terre du circuit d'alimentation c.c. ou à une tresse de mise à la masse reliée à une barre omnibus de terre laquelle est raccordée à l'électrode de terre du circuit d'alimentation c.c.</p> <p>Les appareils dont les conducteurs de terre respectifs sont raccordés au conducteur de terre du même circuit d'alimentation c.c. doivent être installés à proximité les uns des autres (p.ex., dans des armoires adjacentes) et à proximité de la prise de terre du circuit d'alimentation c.c. Le circuit d'alimentation c.c. ne doit comporter aucune autre prise de terre.</p>	D2

Annex NAA Continued

Sub-clause reference from IEC 60950	Requirement	Example of English text for marking/instruction	Example of French text for marking/instruction	
		<p>3) The d.c. supply source is to be located within the same premises as this equipment.</p> <p>4) There shall be no switching or disconnecting devices in the earthed circuit conductor between the d.c. source and the point of connection of the earthing electrode conductor.</p>	<p>La source d'alimentation du circuit c.c. doit être située dans la même pièce que le matériel.</p> <p>Il ne doit y avoir aucun dispositif de commutation ou de sectionnement entre le point de raccordement au conducteur de la source d'alimentation c.c. et le point de raccordement à la prise de terre.</p>	
4.2.9	A compartment that houses a high-pressure lamp as mentioned in 4.2.9 shall be marked where readily visible during any approach to enter the compartment to indicate the risk of explosion.	CAUTION: High-pressure lamp may explode if improperly handled. Refer to lamp replacement instructions.	ATTENTION: Les lampes à haute pression peuvent exploser si elles sont mal utilisées. Confier l'entretien à une personne qualifiée.	D2
4.3.12	Equipment that uses replenishable liquids as indicated in 4.3.12 shall be marked where it will be clearly visible to persons replenishing the liquid with the generic type or the trade name of the liquid to be used.	<p>CAUTION: For continued protection against possible fire, use only:</p> <p>(type of liquid used, for example: alcohol, kerosene and the like) base liquid classed ____ (for example 30 – 40) or lower with respect to fire hazard, or</p> <p>[manufacturer's specific material (trade name) which has been determined to be acceptable for the purpose].</p>	<p>ATTENTION: Pour assurer la protection contre les risques d'incendie, utiliser seulement</p> <p>(type of liquid used, for example: alcohol, kerosene and the like) classé _____ (for example 30 – 40) ou moins en ce qui concerne les risques d'incendie, ou</p> <p>[manufacturer's specific material (trade name) which has been determined to be acceptable for the purpose].</p>	D2
4.3.13	Equipment which produces x-radiation and does not comply with 4.3.13 under all conditions of servicing shall be marked where readily visible during servicing to indicate the presence of radiation. Service conditions include the removal of shields, windows, cages and covers, with or without the chassis removed from its enclosure.	CAUTION: Servicing this unit with circuits energized may involve exposure to x-radiation. Refer to service manual for radiation protection procedure.	ATTENTION: L'entretien de cet appareil alors que les circuits sont sous tension peut entraîner l'exposition à des rayons X. Voir le guide d'entretien pour les précautions à prendre.	D2

Annex NAA Continued

Sub-clause reference from IEC 60950	Requirement	Example of English text for marking/instruction	Example of French text for marking/instruction	
4.7.3	<p>Equipment evaluated for installation in space used for environmental air as described in Section 300-22(c) of the National Electrical Code, ANSI/NFPA 70, and Sections 2-128, 12-010(3) and 12-100 of the Canadian Electrical Code, Part 1, C22.1 shall be marked or provided with installation instructions indicating suitability for installation in such locations.</p> <p>Equipment that is not evaluated for installation in areas covered by Section 300-22(c) of the National Electrical Code, and Sections 2-128, 12-010(3) and 12-100 of the Canadian Electrical Code, Part 1, C22.1 shall not be provided with this marking, nor shall its installation instructions describe such installation.</p>	<p>Suitable for use in environmental air space in accordance with Section 300-22(c) of the National Electrical Code, and Sections 2-128, 12-010(3) and 12-100 of the Canadian Electrical Code, Part 1, C22.1.</p>	<p>Peut être utilisé dans des gaines transportant de l'air traité, conformément à la section 300-22(c) du National Electrical Code et aux articles 2-128, 12-010(3) et 12-100 du Code Canadien de l'électricité, Première partie, C22.1.</p>	D1
5.1.7	See 5.1.7	See 5.1.7	COURANT DE FUITE ÉLEVÉ Raccordement à la terre indispensable avant le raccordement au réseau	DE
5.1.8.2	For pluggable equipment, if leakage current due to ringing voltage exceeds 3,5 mA, a label bearing the warning indicated in this annex, or similar wording, shall be affixed adjacent to telecommunication ports.	<p>HIGH LEAKAGE CURRENT</p> <p>Connect permanent earthing conductor before connecting telephone lines</p>	<p>COURANT DE FUITE ÉLEVÉ</p> <p>Raccordement à la terre indispensable avant le raccordement au réseau.</p>	D2
5.1.8.2	For ringing voltage leakage current:	<p>1. A supplementary equipment earthing conductor is to be installed between the product or system and earth, that is, in addition to the equipment earthing conductor in the power supply cord.</p>	<p>1. Un conducteur de terre additionnel doit être installé entre l'appareil ou le réseau et la terre. Ce conducteur de terre s'ajoute à celui du cordon d'alimentation de l'appareil.</p>	D3



Annex NAA Continued

Sub-clause reference from IEC 60950	Requirement	Example of English text for marking/instruction	Example of French text for marking/instruction	
	<p>Pluggable equipment shall be marked with the complete earthing installation instructions, or with a reference to the earthing installation instructions. Installation instructions furnished with the product shall include prominent mention of the text provided in this annex.</p>	<p>2. The supplementary equipment earthing conductor may be not smaller in size than the unearthed branch-circuit supply conductors. The supplementary equipment earthing conductor is to be connected to the product at the terminal provided, and connected to earth in a manner that will retain the earth connection when the power supply cord is unplugged. The connection to earth of the supplementary earthing conductor shall be in compliance with the appropriate rules for terminating bonding jumpers in Part K of Article 250 of the National Electrical Code, ANSI/NFPA 70, and Article 10 of Part I of the Canadian Electrical Code, Part I, C22.1. Termination of the supplementary equipment earthing conductor is permitted to be made to building steel, to a metal electrical raceway system, or to any earthed item that is permanently and reliably connected to the electrical service equipment earthed.</p> <p>3. Bare, covered or insulated earthing conductors are acceptable. A covered or insulated earthing conductor must have a continuous outer finish that is either green, or green with one or more yellow stripes.</p>	<p>2. La section du conducteur de terre additional ne doit pas être inférieure à celle des conducteurs de dérivation non mis à cette fin et raccordé à la terre de façon que la continuité des masses soit maintenue lorsque le cordon d'alimentation est débranché. La connexion à la terre du conducteur de terre additionnel doit être conforme aux exigences pertinentes visant le raccordement à des tresses de mise à la masse indiquées à la partie K de l'article 250 du NEC (norm ANSI/NFPA 70) et à la section du CCE, Première partie. Le conducteur de terre additionnel peut être raccordé à la structure d'acier du bâtiment, à un réseau de canalisation électrique métallique ou à tout autre point raccordé de façon permanente et sûre à la prise de terre du réseau.</p> <p>3. Les conducteurs de terre nus, recouverts ou isolés sont acceptables. Le revêtement des conducteurs recouverts ou isolés doit être vert ou vert à rayures jaunes.</p>	

Annex NAA Continued

Sub-clause reference from IEC 60950	Requirement	Example of English text for marking/instruction	Example of French text for marking/instruction	
6	<p>Some or all of the indicated instructions may be appropriate for equipment which may be connected to a telecommunications network. The instructions shall be in the form of a separate booklet or sheet, or shall be part of the instruction manual separated in format from the other instructions and appearing before any operating instructions. Symbols, graphics and illustrations, if used, shall be adequately defined. The instructions shall start with the words, "IMPORTANT SAFETY INSTRUCTIONS" or equivalent, emphasized and clearly distinguishable from the rest of the text.</p>	<p>IMPORTANT SAFETY INSTRUCTIONS</p> <p>When using your telephone equipment, basic safety precautions should always be followed to reduce the risk of fire, electric shock and injury to persons, including the following:</p> <ol style="list-style-type: none"> 1. Do not use this product near water, for example, near a bath tub, wash bowl, kitchen sink or laundry tub, in a wet basement or near a swimming pool. 2. Avoid using a telephone (other than a cordless type) during an electrical storm. There may be a remote risk of electric shock from lightning. 3. Do not use the telephone to report a gas leak in the vicinity of the leak. 4. Use only the power cord and batteries indicated in this manual. Do not dispose of batteries in a fire. They may explode. Check with local codes for possible special disposal instructions. <p>SAVE THESE INSTRUCTIONS</p>	<p>IMPORTANTES MESURES DE SÉCURITÉ</p> <p>Certaines mesures de sécurité doivent être prises pendant l'utilisation de matériel téléphonique afin de réduire les risques d'incendie, de choc électrique et de blessures. En voici quelquesunes:</p> <ol style="list-style-type: none"> 1. Ne pas utiliser l'appareil près de l'eau, p.ex., près d'une baignoire, d'un lavabo, d'un évier de cuisine, d'un bac à laver, dans un sous-sol humide ou près d'une piscine. 2. Éviter d'utiliser le téléphone (sauf s'il s'agit d'un appareil sans fil) pendant un orage électrique. Ceci peut présenter un risque de choc électrique causé par la foudre. 3. Ne pas utiliser l'appareil téléphonique pour signaler une fuite de gaz s'il est situé près de la fuite. 4. Utiliser seulement le cordon d'alimentation et le type de piles indiqués dans ce manuel. Ne pas jeter les piles dans le feu: elles peuvent exploser. Se conformer aux règlements pertinents quant à l'élimination des piles. <p>CONSERVER CES INSTRUCTIONS</p>	D2

Annex NAA Continued

Sub-clause reference from IEC 60950	Requirement	Example of English text for marking/instruction	Example of French text for marking/instruction	
6	<p>Telecommunication type connectors and terminals, when not used for connection to a telecommunication network, shall be provided with a marking identifying the specific function or circuit characteristics the connector or terminal is used for.</p> <p>Examples of telecommunication connectors are RJ and CA series modular jacks in the USA and Canada, respectively, 50 pin ribbon connectors, and insulation piercing terminals.</p>			D2
6.3	<p>Equipment intended to be remotely powered over telecommunication wiring systems shall be marked as indicated in this annex adjacent to the receptacle or connection.</p>	<p>"Telephone Power" and the symbol  or the words "See instruction manual."</p> <p>The instruction manual shall include the following:</p> <ul style="list-style-type: none"> a) the current limitations and maximum overcurrent protection for telecommunication circuits; b) reference to the specific power supply or current limiting device provided with the product; c) detailed instructions showing the proper method of installation and connections to the telecommunication wiring system. 	<p>"Alimentation du système téléphonique" and the symbol  or the words "Voir le manuel d'insrtuctions"</p>	D2
6.4	<p>Where No. 26 AWG line cord is required by Figure6C, the telecommunication line cord shall either be provided with the equipment or shall be described in the safety instructions.</p>	<p>"CAUTION – To reduce the risk of fire, use only No. 26 AWG or larger telecommunication line cord."</p>	<p>"ATTENTION – Pour réduire les risques d'incendie, utiliser uniquement des conducteurs de télécommunications 26 AWG au de section supérieure."</p>	D2

Annex NAA Continued

Sub-clause reference from IEC 60950	Requirement	Example of English text for marking/instruction	Example of French text for marking/instruction	
Annex NAB	<p>Equipment which has provisions to connect the earthed conductor of a d.c. supply circuit to the earthing conductor at the equipment shall be provided with a permanent marking located near and in plain view of the field wiring terminals and worded as indicated. Alternatively, the wording can be replaced by the ▲ symbol on the product if the specified wording appears in the installation instructions.</p>	<p>This equipment is designed to permit the connection of the earthed conductor of the d.c. supply circuit to the earthing conductor at the equipment.</p> <p>If this connection is made, all of the following conditions must be met:</p> <ul style="list-style-type: none"> – this equipment shall be connected directly to the d.c. supply system earthing electrode conductor or to a bonding jumper from an earthing terminal bar or bus to which the d.c. supply system earthing electrode conductor is connected. – this equipment shall be located in the same immediate area (such as, adjacent cabinets) as any other equipment that has a connection between the earthed conductor of the same d.c. supply circuit and the earthing conductor, and also the point of earthing of the d.c. system. The d.c. system shall not be earthed elsewhere. – the d.c. supply source is to be located within the same premises as this equipment. – switching or disconnecting devices shall not be in the earthed circuit conductor between the d.c. source and the point of connection of the earthing electrode conductor. 	<p>Cet appareil est conçu pour permettre le raccordement du conducteur relié à la terre du circuit d'alimentation c.c. au conducteur de terre de l'appareil.</p> <p>Pour ce raccordement, toutes les conditions suivantes doivent être respectées:</p> <ul style="list-style-type: none"> – ce matériel doit être raccordé directement au conducteur de la prise de terre du circuit d'alimentation c.c. ou à une tresse de mise à la masse reliée à une barre omnibus de terre laquelle est raccordée à l'électrode de terre du circuit d'alimentation c.c. – les appareils dont les conducteurs de terre respectifs sont raccordés au conducteur de terre du même circuit d'alimentation c.c. doivent être installés à proximité les uns des autres (p.ex., dans des armoires adjacentes) et à proximité de la prise de terre du circuit d'alimentation c.c. Le circuit d'alimentation c.c. ne doit comporter aucune autre prise de terre. – la source d'alimentation du circuit c.c. doit être située dans la même pièce que le matériel. – il ne doit y avoir aucun dispositif de commutation ou de sectionnement entre le point de raccordement au conducteur de la source d'alimentation c.c. et le point de raccordement à la prise de terre. 	D2

Annex NAA Continued

Sub-clause reference from IEC 60950	Requirement	Example of English text for marking/instruction	Example of French text for marking/instruction	
Annex NAB	<p>Equipment which has the earthed conductor of a d.c. supply circuit connected to the earthing conductor at the equipment shall be provided with a permanent marking located near and in plain view of the field wiring terminals and worded as indicated.</p> <p>Alternatively, the wording can be replaced by the ▲ symbol on the product if the specified wording appears in the installation instructions.</p>	<p>This equipment has a connection between the earthed conductor of the d.c. supply circuit and the earthing conductor.</p> <p>This equipment shall be connected directly to the d.c. supply system earthing electrode conductor or to a bonding jumper from an earthing terminal bar or bus to which the d.c. supply system earthing electrode conductor is connected.</p> <p>This equipment shall be located in the same immediate area (such as, adjacent cabinets) as any other equipment that has a connection between the earthed conductor of the same d.c. supply circuit and the earthing conductor, and also the point of earthing of the d.c. system. The d.c. system shall not be earthed elsewhere.</p> <p>The d.c. supply source is to be located within the same premises as this equipment.</p> <p>Switching or disconnecting devices shall not be in the earthed circuit conductor between the d.c. source and the point of the connection of the earthing electrode conductor.</p>	<p>Cet appareil comporte une connexion entre le conducteur relié à la terre du circuit d'alimentation c.c. et son conducteur de terre.</p> <p>Ce matériel doit être raccordé directement au conducteur de la prise de terre du circuit d'alimentation c.c. ou à une tresse de mise à la masse reliée à une barre omnibus de terre laquelle est raccordée à l'électrode de terre du circuit d'alimentation c.c.</p> <p>Les appareils dont les conducteurs de terre respectifs sont raccordés au conducteur de terre du même circuit d'alimentation c.c. doivent être installés à proximité les uns des autres (p.ex., dans des armoires adjacentes) et à proximité de la prise de terre du circuit d'alimentation c.c. Le circuit d'alimentation c.c. ne doit comporter aucune autre prise de terre.</p> <p>La source d'alimentation du circuit c.c. doit être située dans la même pièce que le matériel.</p> <p>Il ne doit y avoir aucun dispositif de commutation ou de sectionnement entre le point de raccordement au conducteur de la source d'alimentation c.c. et le point de raccordement à la prise de terre.</p>	D2

Annex NAA Continued

Sub-clause reference from IEC 60950	Requirement	Example of English text for marking/instruction	Example of French text for marking/instruction	
Annex NAC	Equipment intended for use with a generic secondary protector shall be marked as indicated in this annex. The instructions shall include prominent mention of the type of protection or protective device that is required, along with specific information regarding the location of and installation procedures for the protector.	For use only on telephone wiring containing secondary protection. See instruction manual.	Utiliser seulement avec un réseau téléphonique comprenant un dispositif de protection secondaire. Voir le manuel d'instructions.	D2
Annex NAC	Equipment intended for use with a specific primary or secondary protector shall be marked as indicated in this annex. The instructions shall include prominent mention of the manufacturer and type of protective device that is required, along with specific information regarding the location of and installation procedures for the operator.	For use only on telephone wiring protected by a (manufacturer and type of protector) protector. See instruction manual.	Utiliser seulement avec un réseau téléphonique comprenant un dispositif de protection (manufacturer and type of protector). Voir le manuel d'instructions.	D2

Annex NAB
(normative)

D2 **NAA**

Centralized d.c. power systems and special earthing requirements for d.c. powered equipment
(see 3.6)

NOTE 1 – Underlining to indicate text added to IEC 60950 is not used in this annex.

NOTE 2 – The complete text of Annex NAB is a D2 deviation.

NAB.1 System descriptions

A centralized d.c. power distribution system is a power distribution system consisting of open batteries, charger/rectifier circuits and primary and secondary distribution equipment intended to provide power to equipment loads. Systems rated not less than 48 V have one point directly earthed, the exposed conductive parts of the installation being connected to that point by protective earth conductors. Systems rated less than 48 V may have one point directly earthed.

Two types of systems are recognized according to the arrangement of earthed and protective earth (earthing) conductors, as follows:

- source earthed d.c. power systems, in which the connection to the earthing electrode is located at the source and separate earthed and protective earth conductors are provided throughout the system. See figure NAB.1.
- d.c. power system earthed at the equipment location, in which the connection to the earthing electrode is located in the area where the load equipment is to be installed, typically known as the “earthing window.” See figure NAB.2.

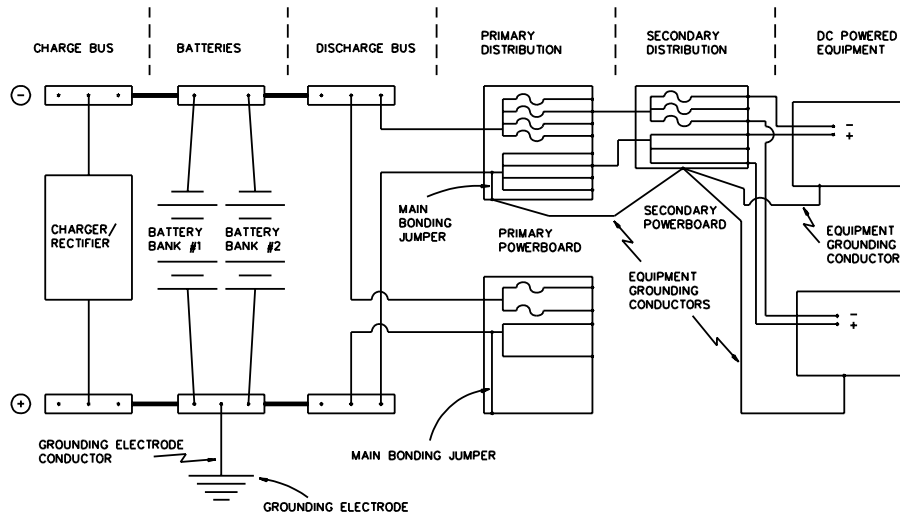

SM225

For the purpose of applying this figure, grounded and grounding are equivalent to earthed and earthing, respectively.

Figure NAB.1 – Typical centralized d.c. power system – plant and distribution source-grounded d.c. power system

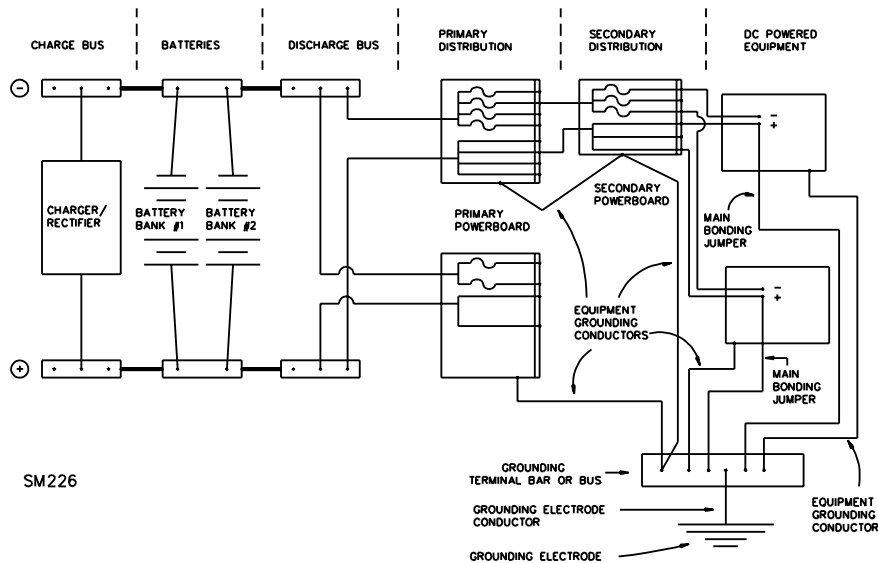

For the purpose of applying this figure, grounded and grounding are equivalent to earthed and earthing, respectively.

Figure NAB.2 – Typical centralized d.c. power system – plant and distribution d.c. power system grounded at the equipment location

NAB.2 General requirements

A centralized d.c. power system is considered to be a SECONDARY CIRCUIT.

Equipment intended to be connected to a centralized d.c. power system shall comply with the requirements in this standard:

- connections to the centralized d.c. power system are subject to the requirements for PRIMARY CIRCUITS and shall be in accordance with 3.2 (AC MAINS SUPPLIES);
- provisions for protective earthing shall be in accordance with 2.6;
- if the earthed supply conductor is connected to the equipment earthing conductor or to the frame of the equipment, protective earthing shall be in accordance with Clause NAB.3;
- unless otherwise specified by the manufacturer via a marking, documented installation practice, product specification sheet provided to the customer, or the like, the voltage ranges considered for testing shall be -40 V d.c. and -56,7 V d.c. for nominal -48 V d.c. systems and $\pm 20\%$ for nominal -60 V d.c. systems. In no case shall the voltage range considered be less than -10 % and + 6 % of the stated nominal voltage unless the unit is intended to be installed only on proprietary systems where it can be demonstrated that the voltage regulation cannot exceed the manufacturer's stated limits.

NAB.3 Special requirements

These requirements apply to equipment where the earthed conductor of the d.c. supply is connected to the equipment earthing conductor or to the frame of the equipment.

For equipment intended to be connected to a d.c. power system earthed at the equipment location, it is permissible for the earthed conductor of the d.c. supply to be connected to the equipment earthing conductor and to the frame of the unit if all of the following conditions are met:

- the equipment is intended to connect directly to the point of earthing of the d.c. system;
- bus bars, bonding jumpers and terminals are provided for the connection of the equipment earthing conductors and the earthing electrode conductor, by permanent wiring methods, to one of the d.c. supply conductors. Such hardware shall be constructed and sized in accordance with the Standard for Dead-Front Switchboards, UL 891, and Switchgear Assemblies, CSA C22.2 No. 31;
- the d.c. supply conductor may be earthed in more than one piece of equipment if all the equipment is located in the same immediate area as the point of earthing of the d.c. system (that is, within the "earthing window");
- means are provided for connection of the equipment to the d.c. source by permanent wiring methods, and no disconnecting device is located in the earthed d.c. circuit conductor between the point of connection to the supply and the point of connection to the earthing electrode and equipment earthing conductors;
- the equipment is marked with instructions for proper earthing and bonding of the system and equipment. The marking shall be permanent and located near and in plain view of the field wiring terminals and worded as indicated in annex NAA for either equipment which a) has provisions to connect the earthed conductor of a d.c. supply circuit to the earthing conductor at the equipment, or, b) has the earthed conductor of a d.c. supply circuit connected to the earthing conductor at the equipment;
- installation instructions are provided for field assembly of earthing and bonding conductors where the connections are not conventional.

Annex NAC
(normative)
Power line crosses
(see 6.4)

D2 **NAA**

NOTE 1 – Underlining to indicate text added to IEC 60950 is not used in this annex.

NOTE 2 – The complete text of Annex NAC is a D2 deviation.

NAC.1 Equipment evaluation

Equipment is to be evaluated while in each operating state that affects compliance (usually, on-hook and off-hook).

Equipment which functions as either terminal or series equipment is to be evaluated for both functions.

Equipment installed by SERVICE PERSONNEL and intended for use only with a specified primary protector that complies with the Standard for Protectors for Paired Conductor Communication Circuits, UL 497, and CSA C22.2 No. 226, Protectors in Telecommunication Networks, or a secondary protector that complies with the Standard for Secondary Protectors for Communication Circuits, UL 497A, and CSA C22.2 No. 226, or both, is to be evaluated either together with the protector(s) or to the let-through voltage and current characteristics of the protector(s). A secondary protector simulator is to be used when the secondary protector does not have a specified current limit.

NOTE – Telecommunication equipment often is used with a primary or secondary protector. A primary protector is a voltage limiting device. A secondary protector is a current limiting device. A secondary protector may, but is not required to, contain voltage limiting acceptable for protecting telephone equipment.

PLUGGABLE EQUIPMENT TYPE A that is not installed by SERVICE PERSONNEL is to be evaluated with and without the power-supply cord earthing lead connected to earth if that earthing can affect compliance.

NAC.2 Test conditions

Test voltages are to be applied to a representative pair or pairs of the equipment's leads which connect to outside cable as follows (M indicates differential mode, L indicates common mode and F indicates 4-wire test mode):

– Terminal equipment with an earthing connection is to be subjected to common mode (longitudinal) L-type overvoltage test conditions using the test circuit described in figure NAC.1. Terminal equipment is to be subjected to differential mode (metallic) M-type overvoltage test conditions using the test circuit described in figure NAC.2; if the equipment also has an earthing connection, either tip is to be earthed or ring is to be earthed during testing, whichever is more severe. Terminal equipment which connects to a 2-pair (4-wire) TELECOMMUNICATION NETWORK is to be subjected to pair-to-pair F-type overvoltage test conditions using the test circuit described in figure NAC.3.

– Series equipment is to be subjected to:

- all common mode, differential mode and 4-wire tests without terminal equipment being connected; and
- differential mode tests M-2, M-3 and M-4 with terminal equipment connections short-circuited.

The open circuit voltage at 50 or 60 Hz, and short-circuit current (set before the test voltage is applied) available from the voltage source, are given in the following test requirements.

Tests M-1, L-1 and F-1 These tests simulate contact between a power system primary and a telecommunications cable.

Test Condition 1: 600 V, 40 A, applied for 1,5 s.

NOTE 1 – The L-1 test may be conducted on one lead at a time.

Tests M-2, L-2 and F-2 These tests simulate short-term induction as a result of a power system primary fault to a multi-earth neutral.

Test Condition 2: 600 V, 7 A, applied for 5 s.

Tests M-3, L-3 and F-3 These tests simulate long duration induction as a result of a power system fault to earth.

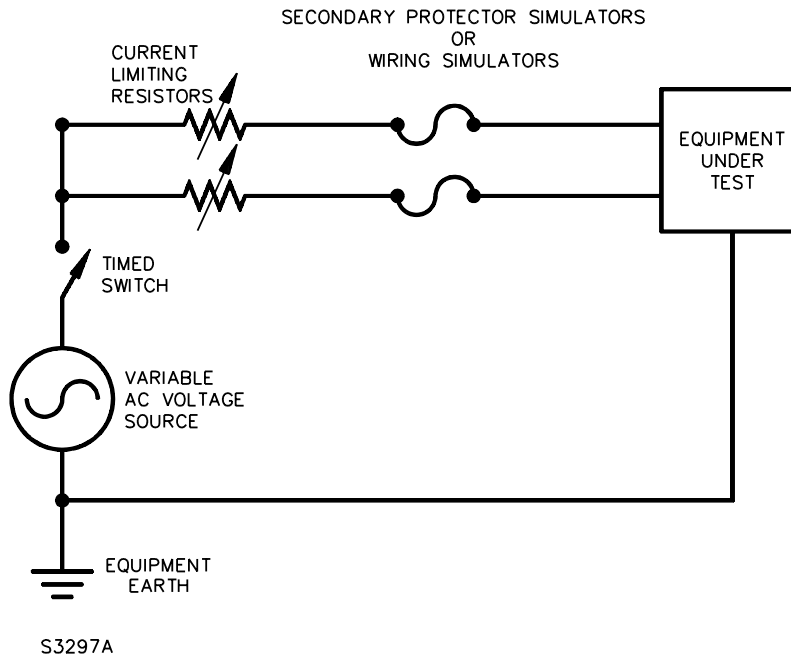

Figure NAC.1 – Circuit for common mode (longitudinal) overvoltage tests

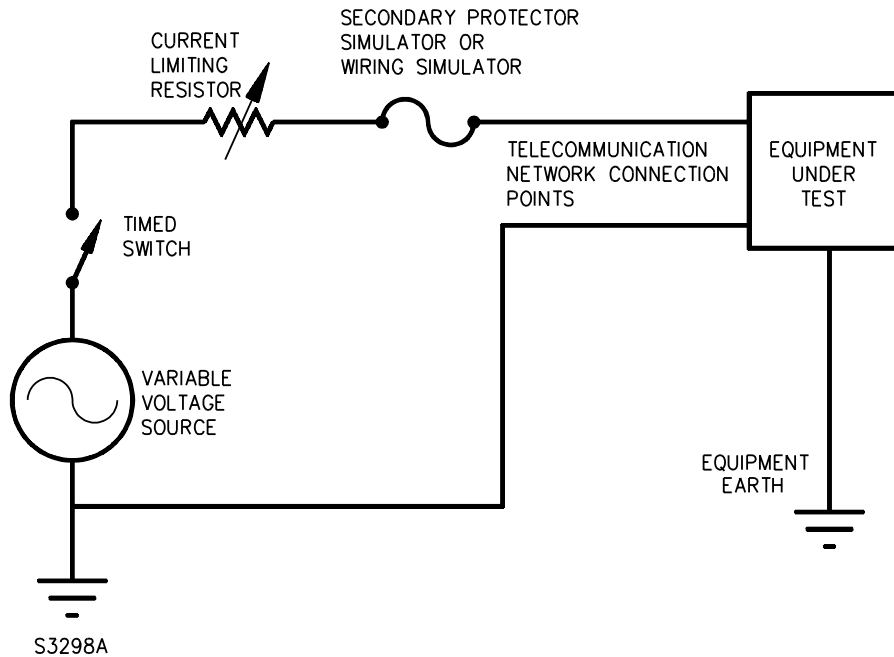

Figure NAC.2 – Circuit for differential mode (metallic) overvoltage tests

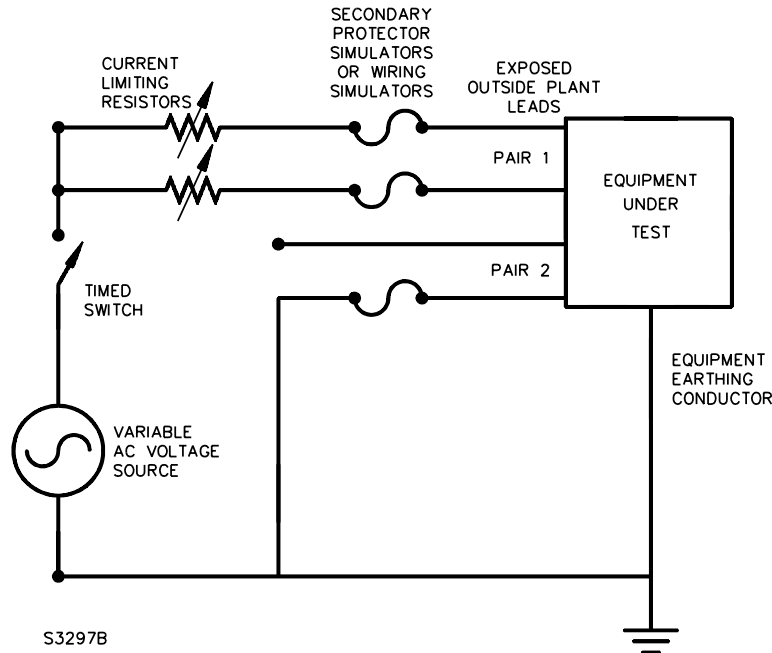

Figure NAC.3 – Circuit for 4-wire overvoltage tests

Test Condition 3: 600 V, 2,2 A, applied per Test Duration.

Test Condition 3A: If an open circuit condition occurred during Test Condition 3, an additional test is to be conducted at 600 V, at a current no greater than 2,2 A, whose value does not result in an open circuit condition and is intended to produce maximum heating, applied per Test Duration.

NOTE 2 – Where a fuse causes the open circuit in Test Condition 3, as an alternative to testing the equipment with its fuse in place, a short-circuit current value of up to 135 percent of the fuse rating, with the fuse bypassed, may be used.

Tests M-4, L-4 and F-4 If a voltage limiter, rated by the manufacturer to conduct at 285 V peak or more, operated during Test Condition 3 or 3A, the following test is to be conducted.

Test Condition 4: A voltage whose peak value is below the conduction voltage, at a current no greater than 2,2 A, whose value does not result in an open circuit condition and is intended to produce maximum heating, applied per Test Duration.

NOTE 3 – Where a fuse causes the open-circuit in Test Condition 3, as an alternative to testing the equipment with its fuse in place, a short-circuit current value of 135 percent of the fuse rating, with the fuse bypassed, may be used.

NOTE 4 – A voltage limiting device that does not have a breakdown characteristic (such as a metal oxide varistor) is considered to be conducting when the current through it exceeds 5 mA.

Test L-5 This test simulates a contact between a power mains cable and a telecommunications cable.

Test Condition 5: 120 V, 25 A, applied per Test Duration.

Test Duration

Test Conditions 3, 4 and 5 are to be conducted for 30 minutes or until an open circuit occurs through the action of a current limiting device.

NOTE 5 – An unacceptable condition will typically manifest itself within 30 minutes, hence the tests are normally limited to 30 minutes. If at the end of 30 minutes it appears possible that a risk of fire, electric shock or injury to persons will result eventually, the test is to be continued until ultimate results are obtained – maximum 7 hours.

NAC.3 Test set-up

NAC.3.1 Equipment

a) Equipment is to be mounted as intended for its use. Tests may be conducted on either the equipment as an assembly, on individual subassemblies, or on a partial assembly containing those components that may be exposed to an overvoltage condition. Two single plies of cheesecloth are to be wrapped tightly around the assembly, subassembly or partial assembly.

NOTE 1 – Bleached cotton cheesecloth, running 28 – 30 m/kg and having what is known as a “count of 32 × 28 inch” – that is, for any square inch, 32 threads in one direction and 28 threads in the other direction (for any square centimeter, 13 threads by 11 threads), is considered suitable for this purpose.

NOTE 2 – Cheesecloth meeting the requirements of CSA C22.2 No. 0 is considered suitable for this purpose.

b) Equipment that has a removable telecommunication line cord is to be connected to the test circuit with a line cord having 0,4 mm (No. 26 AWG) or larger copper wire conductors and not more than 1 Ω total resistance.

c) Equipment that has a permanently attached telecommunication line cord (one that requires use of a tool to remove) or a permanently attached handset cord that can be subjected to overvoltage conditions, and for which these cords have not been approved as component parts, is to have the cord or cords prepared for testing as described in the Standard for Communication Circuit Accessories, UL 1863, and CSA C22.2 No. 233, Cords and Cord Sets for Communication Systems.

d) Functional circuitry is to be used for each test. Circuitry that is damaged during testing may be either repaired or replaced for subsequent tests. After any of the specified tests, equipment may be returned to ambient temperature before performing any additional tests. Alternatively, separate samples may be used for each test.

NAC.3.2 Wiring simulator

A wiring simulator, intended to indicate the maximum permissible I^2t imposed on telecommunication wiring, is to be used in Test Conditions 1 and 5 unless the equipment is to be used and tested with a suitable secondary protector or secondary protector simulator. Test Conditions 2, 3 and 4 are to be evaluated without use of a wiring simulator. The wiring simulator is to consist of one of the following:

- a) A 50 mm length of 0,2 mm (No. 32 AWG) bare or enameled solid copper wire. For Test Condition 1, a fuse having a time-current characteristic comparable to a 0,2 mm wire (a Bussman Mfg. Co. Type MDL-2 A fuse or equivalent is acceptable) may be used. However, equipment supplied with a line cord having 0,4 mm (No. 26 AWG) copper conductors, and having installation instructions for equivalent replacement cords, is evaluated with the line cord provided.
- b) For Test Condition 1, current probe used with a 300 mm length of at least 0,5 mm (No. 24 AWG) copper wire.
- c) A 300 mm length of 0,4 mm (No. 26 AWG) solid copper wire connected to a representative installation (including wiring and connectors) of the manufacturer's equipment. This option may be used only when a manufacturer specifies the complete installation from the network interface to the equipment, and is only intended for dedicated installations such as PBX systems or other controlled installations. The wire is to be draped with two single plies of the cheesecloth described in NAC.3.1. The representative installation is to take into account the type of wiring, connections and installation methods (for example, fanning out of individual conductors and wire bending) which are specified in the manufacturer's installation instructions.

NAC.3.3 Secondary protector simulator

A secondary protector simulator, intended to simulate the maximum permissible I^2t allowed by a generic secondary protector, is to be used in Test Conditions 1 and 5. The secondary protector simulator is to consist of the test fuse used in the Standard for Secondary Protectors for Communication Circuits, UL 497A and CSA C22.2 No. 226, Protectors in Telecommunication Equipment, to indicate proper operation of a secondary protector. Test Conditions 2, 3 and 4 are to be evaluated without use of a secondary protector simulator.

NAC.4 Compliance

Compliance is checked by all of the following:

a) There shall be no ignition or charring of the cheesecloth indicator. Charring is deemed to have occurred when threads have been reduced to char by a glowing or flaming condition.

b) When used in the test circuit as appropriate, the wiring simulator shall not be overstressed according to the following criteria:

– the fuse or device or wire used as the wiring simulator shall not interrupt the current during the test; or

– for Test Condition 1, integral I^2t measured with the current probe shall be less than 100 A²-s.

NOTE – Although the secondary protector simulator may be the same device as the wiring simulator, it serves a different purpose. When the secondary protector simulator is specified for use in the test circuit, it is allowed to interrupt the test current.

c) After the completion of the overvoltage tests, the equipment under test shall comply with either the dielectric voltage-withstand test requirements with all components in place, or the leakage current test requirements applicable to the equipment.

Annex NAD
(informative)
Terminology

DE

This annex identifies examples of terminology in IEC 60950 that is not considered to be suitable in the U.S. due to legal considerations, and provides the appropriate replacement text. Use of such terminology elsewhere in IEC 60950 is to be similarly replaced.

NOTE 1 – Underlining to indicate text added to IEC 60950 is not used in this annex.

NOTE 2 – The complete text of Annex NAD is a DE deviation.

Sub-clause reference	Text in IEC 60950	Appropriate replacement text for U.S.
1.4.1	the test is not made	the test need not be made
1.7.2	Sufficient information shall be provided to the USER concerning any condition necessary to ensure that, when used as prescribed by the manufacturer, the equipment is unlikely to present a hazard within the meaning of this standard.	Information shall be provided to the USER concerning the intended installation, operation and repair of the equipment such that the risks of electric shock, hazardous energy level, injury to persons and fire are reduced.
2.6.5.1	assured	provided
4.2.8	protection against	reduction of the risks of injury due to
4.3.10	so constructed that no dangerous concentration of these materials can exist and that no hazard within the meaning of this standard is created	so constructed to reduce the risk from dangerous concentration of these materials and to reduce the risk created
4.3.12	avoid the risk	reduce the risk
4.4.1	to provide adequate protection against the risk of personal injury	to reduce the risk of injury to persons
5.3.1	remain safe	not introduce a hazard

Annex NAE
(informative)

D1

U. S. and Canadian regulatory requirements

This annex provides examples of and references for regulatory requirements that may apply to equipment. Applicability of these requirements is dependent on the construction of the equipment and its intended installation and use.

This annex is not intended to provide a complete list of all of the applicable requirements, only to serve as a reference for requirements that most commonly apply to this type of equipment. For complete requirements, the National Electrical Code, ANSI/NFPA 70, the Canadian Electrical Code, Part I, C22.1, or other referenced document must be consulted.

Any undated reference to a code or standard appearing in the requirements of this standard shall be interpreted as referring to the latest edition of that code or standard.

NOTE 1 – Underlining to indicate text added to IEC 60950 is not used in this annex.

NOTE 2 – The complete text of Annex NAE is a D1 deviation.

Annex NAE

D1

Clause No.	Topic/summary	NEC	CEC
1.1.1 (1.5.5)	Cables used in computer rooms See 1.5.5 (1.1.1).		4-010(2)(i), 12-020 60-316
1.1.2	Additional requirements Special installation methods are required for equipment connected to wire-line communication facilities serving high voltage electric power stations operating at greater than 1 kV. These requirements do not cover the equipment used in the design of such installations. Special system design requirements, such as those covered by ANSI/IEEE 487, Recommended Practice for the Protection of Wire-Line Communication Facilities Serving Electric Power Stations, shall be followed to reduce the risks associated with wire-line communication facilities serving such power stations.	90-2(b)(5) ANSI/IEEE 487	Section 0
1.1.2, Annex T	Outdoor use equipment Equipment intended for use outdoors shall be evaluated in accordance with the Standard for Enclosures for Electrical Equipment, UL 50, or Special Purpose Enclosures, CAN/CSA C22.2 No. 94, and shall be marked with a suitable outdoor use enclosure designation compatible with the National Electrical Code, ANSI/NFPA-70, or the Canadian Electrical Code.	110-11	22-102
1.1.3 (1.5.5)	Building wiring See 1.5.5 (1.1.3).		2-128, Appendix B Note 2-130, Section 4, 8, 10, 12 and 60

Annex NAE Continued

D1

Clause No.	Topic/summary	NEC	CEC
1.5.5 (1.1.3) (3.5.3)	<p>Building wiring</p> <p>Wires and cables installed as part of building wiring systems (premises wiring, facility wiring, etc.) shall comply with the applicable provisions in the National Electrical Code, ANSI/NFPA 70, and the Canadian Electrical Code, Part I, C22.1, and, except for cables run completely within a computer room, are not within the scope of this standard. For example:</p> <p>Conductors for general wiring</p> <p>Cables extending beyond a computer room</p> <p>Class 1, 2 and 3 circuits</p> <p>Optical fiber cables</p> <p>Communication circuits</p>	<p>Article 300, 310</p> <p>645-6</p> <p>Article 725</p> <p>Article 770</p> <p>Article 800</p>	<p>Section 12</p> <p>Section 4</p>
1.5.5 (1.1.3) (3.5.3)	<p>Building wiring and cable used in ducts, plenums and other air-handling space</p> <p>Building wiring and cable used in ducts, plenums and other air-handling space are subject to special requirements and are not within the scope of this standard.</p> <p>General requirements</p> <p>Class 2 and 3 circuits</p> <p>Optical fiber cables</p> <p>Communication circuits</p>	<p>300-22</p> <p>725</p> <p>770</p> <p>800</p>	<p>12-010</p> <p>Section 4</p> <p>Section 16</p> <p>Section 56</p> <p>Section 60</p>
1.5.5 (1.1.1) (3.5.3)	<p>Cables used in computer rooms</p> <p>Cables installed within a computer room are within the scope of this standard and shall also comply with the applicable provisions of the National Electrical Code, ANSI/NFPA, and the Canadian Electrical Code, Part I, C22.1.</p>	<p>645-5</p>	<p>12-020</p> <p>4-010(2)(i)</p> <p>60-316</p>

Annex NAE Continued

D1

Clause No.	Topic/summary	NEC	CEC
1.5.5	<p>External interconnecting cables</p> <p>Type DP or equivalent cable is required for cabling under raised floors in computer rooms. Type DP-1 or DP-1P cable is suitable for use in any external circuit operating at 600 volts or less. Type DP-2 or DP-2P cable is suitable for use in any external circuit operating at 300 volts or less.</p> <p>Generally, for computer room applications, it is assumed that any cable over 3,05 m in length coiled or uncoiled, can be used under raised floors.</p> <p>Cables extending beyond the computer room are subject to the applicable requirements in the National Electrical Code, ANSI/NFPA 70, and the Canadian Electrical Code, Part I, C22.1, for building wiring.</p> <p>For installations other than computer rooms, cables are subject to the applicable requirements in the National Electrical Code, ANSI/NFPA 70, except cables not exceeding 3,05 m may consist of appliance wiring material and may be evaluated as part of equipment. Special constructions may warrant additional considerations.</p> <p>For circuits supplied by Limited Power Sources, Article 725 of the National Electrical Code, ANSI/NFPA 70, permits the use of CL2 or permitted cable substitutions. See Table NAE.1.</p> <p>For cabling less than 3,05 m, which are types not specified in the National Electrical Code or Canadian Electrical Code, each detachable external interconnecting cable (with terminations) furnished as part of the equipment shall be marked or similarly identified in the installation instructions with the name, trademark or trade name of the organization that is responsible for the equipment and with the organization's identifying number or equivalent designation for the cable, or the cable must be evaluated separately from the equipment.</p> <p>This marking is required to allow authorities having jurisdiction to identify external interconnecting cables that are evaluated as a part of the system and that are not separately evaluated.</p> <p>Telephone line cords, extension cords and the like shall comply with the requirements of the Standard for Communication Circuit Accessories, UL 1863, and Cords and Cord Sets for Communication Systems, CSA C22.2 No.233.</p>	<p>645-5(c) 645-5(d) 645-6 NFPA 75</p> <p>300</p> <p>725</p> <p>800-4</p>	<p>12-020 60-306 60-318</p> <p>60-102</p>

Annex NAE Continued

D1

Clause No.	Topic/summary	NEC	CEC
1.7.1	<p>Rated voltage marking</p> <p>Based on nominal rating conventions, the following marking schemes shall be used:</p> <p>The voltage rating for equipment with more than one phase supply conductor and an earthed neutral supply conductor shall indicate the phase-to-earth RATED VOLTAGE and the phase-to-phase RATED VOLTAGE, separated by a solidus (/), and shall give an indication of the number of phases of the supply. In order to differentiate this marking from multiple voltage ratings, the number of supply wires, including the neutral, shall also be provided.</p> <p>For example:</p> <p>120/240 V, 3 wire means the voltage is supplied by two phase wires and one neutral wire with 120 V between each phase conductor and the neutral and 240 V between the phase conductors.</p> <p>120/208 V, 3-phase 4 wire means the voltage is supplied by a three phase power system and one neutral wire with 120 V between each phase conductor and the neutral and 208 V between phases.</p> <p>For cord connected equipment, the RATED VOLTAGE specified shall not exceed the rating of the attachment plug.</p> <p>A voltage rating that exceeds the attachment plug cap rating may be acceptable if it does not exceed the extreme operating conditions in table 2 of Preferred Voltage Levels for AC Systems, 0 to 50,000 V, CSA CAN3-C235, and if it is part of a range that extends into "Normal Operating Conditions." The voltage rating shall not be lower than that specified for "Normal Operating Conditions" in table 2 of CSA CAN3-C235 unless it is part of a range that extends into "Normal Operating Conditions." For example, a marking of 100 V would not be allowed, but 100 – 118 V would be acceptable. A marking of 127 V would not be allowed, but 100 – 127 V would be acceptable.</p> <p>See also 1.7.7.</p>	220-2 and ANSI C84.1-1989	2-100, 2-101 CSA/CAN3-C235
1.7.2 (2.5)	<p>Markings for Class 2 terminals</p> <p>Wiring terminals intended to supply Class 2 outputs in accordance with Article 725 of the National Electrical Code, ANSI/NFPA 70, or Section 16 of the Canadian Electrical Code, Part 1, C22.1, shall be marked with the voltage rating and "Class 2" or the equivalent. The marking shall be located adjacent to the terminals and shall be visible during wiring.</p>	Tables 11(a) Tables 11(b)	16-204
1.7.2 (3.2.1) (3.6)	<p>Polarity marking for d.c. powered equipment field wiring terminals</p> <p>See 3.6 (1.7.2)(3.2.1).</p>		2-100(1)(m)
1.7.7 (2.6.4.1) (3.3)	<p>Identification of the protective earthing terminal (terminal for the connection of the equipment grounding conductor or bonding conductor) for permanently connected equipment</p>	250-126	CSA C22.2 No. 0.4 [Clause 3.5.1.2(c)]

Annex NAE Continued

D1

Clause No.	Topic/summary	NEC	CEC								
	<p>The terminal for the connection of the equipment earthing conductor (grounding conductor or bonding conductor) shall be identified by (1) a green-colored, not readily removable terminal screw with a hexagonal head; (2) a green-colored, hexagonal, not readily removable terminal nut; or (3) a green-colored pressure wire connector. If the terminal is not visible, the conductor entrance hole shall be marked with the word "green" or "ground," the letters "G" or "GR" or the grounding symbol (IEC 60417, No. 5019) or otherwise identified by a distinctive green color.</p> <p>The term "Protective Earth" or its abbreviation "PE" are not commonly used in Canada or the U.S. Therefore, "G," "GND," "GROUND," or the grounding symbol should be used in conjunction with these terms.</p>										
2.1.1	<p>Polarity of lampholders</p> <p>If a neutral conductor is provided in equipment that contains an Edison-base screw shell type of lampholder, the neutral conductor shall be connected to the screw shell of the lampholder.</p>	410-42(a), 410-47	30-602 CSA C22.2 No. 0 (Clause 4.9)								
2.5 (1.7.2)	<p>Markings for Class 2 terminals</p> <p>See 1.7.2 (2.5).</p>		16-204 (supply marking)								
2.5	<p>Overcurrent protection for Class 2 limiting</p> <p>Where overcurrent protection is required for Class 2 and Class 3 limiting in accordance with the National Electrical Code, ANSI/NFPA 70, the overcurrent device shall not be interchangeable with devices of higher ratings. A marking is not sufficient regardless of the location of the device.</p> <p>Where a limited power source is used to provide current limiting to external wiring in accordance with the National Electrical Code, ANSI/NFPA 70, a fuse, if used, shall not be operator-accessible unless it is not interchangeable.</p>	Tables 11(a) and 11(b)	16-206								
2.6	<p>Provisions for protective earthing</p> <p>The terms "protective earth," "protective earthing" and "earthing" are not commonly used in Canada or the U.S. For connections to the grounding system, the following terms should be applied as defined in the Canadian Electrical Code(CEC), Part I , C22.1, and/or the National Electrical Code (NEC), ANSI/NFPA 70. These terms appear in parentheses, where appropriate:</p> <table border="0"> <tr> <td>Bonding Conductor (CEC)</td> <td>Grounding Conductor (CEC, NEC)</td> </tr> <tr> <td>Grounded (CEC, NEC)</td> <td>Grounding Conductor, Equipment (NEC)</td> </tr> <tr> <td>Grounded Conductor (NEC)</td> <td>Grounding Electrode Conductor (NEC)</td> </tr> <tr> <td>Grounding (CEC)</td> <td>Grounding System (CEC)</td> </tr> </table>	Bonding Conductor (CEC)	Grounding Conductor (CEC, NEC)	Grounded (CEC, NEC)	Grounding Conductor, Equipment (NEC)	Grounded Conductor (NEC)	Grounding Electrode Conductor (NEC)	Grounding (CEC)	Grounding System (CEC)	Article 100	Section 0
Bonding Conductor (CEC)	Grounding Conductor (CEC, NEC)										
Grounded (CEC, NEC)	Grounding Conductor, Equipment (NEC)										
Grounded Conductor (NEC)	Grounding Electrode Conductor (NEC)										
Grounding (CEC)	Grounding System (CEC)										
2.6 (2.7.1)	<p>Output receptacle circuit grounding</p> <p>Units having receptacles for the output alternating current power connections which are generated from an internal separately derived source (ie: provided with transformer isolation internal to the equipment and electronically isolated from the mains supply), shall have the grounded circuit conductor bonded to protective earth.</p> <p>The bonding jumper shall be based upon the maximum fault current of the circuit and shall not be less than 8 AWG.</p>	250-20(d), 645-15									

Annex NAE Continued

D1

Clause No.	Topic/summary	NEC	CEC
2.6 (3.6)	Special earthing (grounding) conditions for d.c. powered equipment See 3.6 (2.6).		10-102, 10-104, 10-202, 10-402, and 10-810
2.6.1 (3.6)	Earthing (grounding) of d.c. powered equipment See 3.6 (2.6.1).		10-102, 10-104, 10-202, 10-402, and 10-810
2.6.3.2	Size of protective bonding conductors	250-20	10-106
2.6.4.1 (1.7.7) (3.3)	Identification of the protective earthing terminal (terminal for the connection of the equipment grounding conductor or bonding conductor) for permanently connected equipment See 1.7.7 (2.6.4.1) (3.3).		CSA C22.2 No. 0.4 [Clause 3.5.1.2(c)]
2.6.4.1 (3.3.4, Table 3D)	Range of earthing conductor (equipment grounding conductor or bonding conductor) sizes to be accepted by field wiring terminals Terminals must be suitable for the wire gauges commonly used in the U.S. and Canada. It is required that current-carrying conductors be rated 125 percent of the equipment rating; therefore, once the equipment rating exceeds 80 percent of the capacity of the wiring in the branch circuit, the next higher capacity wire gauge must be used. Refer to the appropriate article in the National Electrical Code, ANSI/NFPA 70, and the Canadian Electrical Code, Part 1, C22.1, for ampacity tables.	250-122 Table 250-122	10-814 Table 16
2.7 (2.7.1) (3.6)	Overcurrent and earth (ground) fault protection for d.c. powered equipment See 3.6 (2.7) (2.7.1).		
2.7.1	Branch circuit protection for receptacles Standard supply outlets and receptacles shall be protected by an overcurrent device in either the equipment or the branch circuit, rated or set at not more than the rating of the outlet or receptacle. The overcurrent device shall be of a type that is suitable for branch circuit protection in accordance with the National Electrical Code, ANSI/NFPA 70, and the Canadian Electrical Code, Part I, C22.1, unless it is supplied by a secondary circuit. Standard supply outlets and receptacles are considered an extension of the branch circuit. Equipment that can plug into these receptacles is evaluated based on the branch circuit protection normally associated with the type of receptacle. For example, to comply with both U.S. and Canadian Electrical Code requirements, a 15 A, 125 V receptacle is assumed to have branch circuit protection rated 15 A.	210-20, 240-10 410-56(i)	14-012 14-600
2.7.1	Marking for branch circuit overcurrent protection Non-motor-operated equipment that is intended to be connected to a dedicated branch circuit shall be marked with the overcurrent protective device rating if (1) the equipment is rated 13,3 A or less and is not adequately protected by an overcurrent protective device rated 20 A, or (2) the equipment is rated more than 13,3 A and is not adequately protected by an overcurrent protective device rated 150 percent of the appliance rating. Where motor overload protection external to the appliance is required, the appliance shall be so marked.	422-11(e) 422-60	

Annex NAE Continued

D1

Clause No.	Topic/summary	NEC	CEC								
2.7.1	Overcurrent protection for appliances Contains requirements for sizing branch circuits for appliances. If special overcurrent devices separate from the equipment are required, data for selection of these devices shall be marked on the appliance.	422-11	14-104 Table 13								
2.7.1 (2.7) (3.6)	Overcurrent and earth fault protection for d.c. powered equipment See 3.6 (2.7) (2.7.1).										
2.7.1	Overcurrent protection for distribution transformers Special overcurrent protection is required for individual transformers that distribute power to other units over branch circuit wiring. Typically, these requirements apply to transformers rated not less than 10 kVA, with an output of not less than 100 V.	450-3(b) Table 450-3(b)	26-254 26-256								
2.7.1	Overcurrent protection for panelboards Contains additional requirements for equipment provided with panelboards.	384-16(a)	14-606								
3.1.1	Overcurrent protection of wiring Section 310-15 of the National Electrical Code, ANSI/NFPA 70, and Section 4 of the Canadian Electrical Code, Part I, C22.1, give guidance on the ampacities of conductors. Any overcurrent device is suitable for use with a conductor that meets the following conditions: <ul style="list-style-type: none"> – The length of the conductor does not exceed 3,05 m. – The conductor is located completely within the enclosure of the equipment. – The ampacity of the conductor is not less than the rating of the overcurrent protective device at the termination of the conductor. An overcurrent device rated not more than 3 times the ampacity of the conductors is suitable if all of the following conditions are met: <ul style="list-style-type: none"> – The length of the conductor does not exceed 7,62 m. – The conductor is located completely within the enclosure of the equipment or is enclosed in a suitable raceway. – The conductor terminates at its load end in one or more overcurrent protective devices. – The ampacity of the conductor is not less than the sum of the ratings of the overcurrent protective devices supplied by the conductor. For solid bus bars, the following meets this requirement: <table border="0" style="width: 100%; border-collapse: collapse;"> <thead> <tr> <th style="text-align: left;"><u>Material</u></th> <th style="text-align: left;"><u>Overcurrent protection</u></th> </tr> </thead> <tbody> <tr> <td>Copper</td> <td>Low enough to limit the current density in the bus bar to: 4,65 A/mm² of bus bar cross section</td> </tr> <tr> <td>Electrical-conductor (EC) grade of aluminum (conductivity is 61 percent of IACS)</td> <td>3,10 A/mm² of bus bar cross section</td> </tr> <tr> <td>Aluminum having a conductivity of 55 percent of IACS</td> <td>2,75 A/mm² of bus bar cross section</td> </tr> </tbody> </table>	<u>Material</u>	<u>Overcurrent protection</u>	Copper	Low enough to limit the current density in the bus bar to: 4,65 A/mm ² of bus bar cross section	Electrical-conductor (EC) grade of aluminum (conductivity is 61 percent of IACS)	3,10 A/mm ² of bus bar cross section	Aluminum having a conductivity of 55 percent of IACS	2,75 A/mm ² of bus bar cross section	240-21(b)(1) 240-21(b)(2) 310-15	4-004 4-014 14-100
<u>Material</u>	<u>Overcurrent protection</u>										
Copper	Low enough to limit the current density in the bus bar to: 4,65 A/mm ² of bus bar cross section										
Electrical-conductor (EC) grade of aluminum (conductivity is 61 percent of IACS)	3,10 A/mm ² of bus bar cross section										
Aluminum having a conductivity of 55 percent of IACS	2,75 A/mm ² of bus bar cross section										

Annex NAE Continued

D1

Clause No.	Topic/summary	NEC	CEC
3.2	Connection to a.c. mains supplies Wiring methods used for the connection of the equipment to the AC MAINS SUPPLY shall be in accordance with the National Electrical Code, ANSI/NFPA 70, and the Canadian Electrical Code, Part I, C22.1.	110-8	Section 12
3.2.1 (3.6)	Connections to a d.c. power system (d.c. branch circuit) See 3.6 (3.2.1).		
3.2.1	Methods of connection Flexible cords and plugs are permitted for portable and STATIONARY EQUIPMENT and for fixed equipment where the fastening means and mechanical connections of the equipment are designed to permit removal for maintenance and repair. (Equipment such as automated teller machines (ATMs) and similar bank equipment, which are typically installed in banks, financial institutions, supermarkets, etc., are examples of such fixed equipment where flexible cords and plugs are permitted.) Flexible cords must be provided with an attachment plug for connection to the branch circuit. Attachment plugs shall be rated not less than 125 percent of the rated current of the equipment. CLASS II EQUIPMENT provided with 15- or 20-A standard supply outlets, Edison-base lampholders or a single pole disconnect device shall be provided with a polarized type attachment plug.	400-7(a) 400-7(b) 210-20(a), 210-23(a), 210-23(b), 422-4(a), 422-10(a), 645-5(a) 422-40	4-010 CSA C22.2 No. 0 8-104, 26-704, 8-302(3) 26-1000 CSA C22.2 No. 42
3.2.1 (1.7.2) (3.6)	Polarity marking for d.c. powered equipment field wiring terminals See 3.6 (1.7.2) (3.2.1).		
3.2.3	Connection of wiring systems (i.e. conduit, raceways, etc.) Equipment shall have provision for connecting and securing a field wiring system. For certain locations, such as some Restricted Access Locations using low voltage d.c. systems, open wiring systems may be permitted. Equipment intended solely for installation in such locations need not be provided with a provision for connecting and securing a field wiring system. However, a method of securing wiring or instructions shall be provided to ensure the installed wiring is adequately protected from abuse.	300-10, 300-11, 300-12	12-914, 12-918, 12-916
3.2.3	Permanently connected equipment		
3.2.3	Sizes of cables and conduits Trade sizes of different size conduits and the number type and ampacity of cables allowed to be used with different sized conduits are covered in the national codes. Tables NAE.2 and NAE.3 are provided for reference.	Appendix C	Section 4 Section 12 Tables 6 – 10
3.2.3	Terminals and leads for field wiring connections Equipment shall be provided with either terminals or leads for connection of field installed wiring. Leads shall not be smaller than No. 18 AWG (0,82 mm ²) and not less than 152 mm in length.	110-14, 300-14, 402	12-3002(4) CSA C22.2 No. 0 30-404

Annex NAE Continued

D1

Clause No.	Topic/summary	NEC	CEC
3.2.5	<p>Cord connected equipment</p> <p>The length of a power supply cord shall not exceed 4,5 m.</p> <p>The minimum length of a power supply cord shall be 1,5 m unless it is intended for a special installation, such as dedicated equipment intended to be mounted near a receptacle.</p> <p>Power supply cords shall have conductors with cross-sectional areas sufficient for the rated current of the equipment.</p> <p>Conductors shall be sized based on the requirements in the National Electrical Code, ANSI/NFPA 70, and the Canadian Electrical Code, Part I, C22.1.</p> <p>Power supply cords and cord sets shall incorporate flexible cords suitable for the particular application or shall be of a type at least as serviceable for the particular application. Table NAE.4 lists common applications and associated suitable cord types. Tables NAE.5 and NAE.6 specify the allowable ampacity for flexible cords and cables.</p>	<p>400-8 (NFPA 75, 5-2.2)</p> <p>210-52</p> <p>400-5, 400-12</p> <p>400-3, 400-4</p> <p>Table 400-5(A)</p>	<p>4-010(3)</p> <p>Individual CSA Part II Standards</p> <p>4-014, Table 11, 4-012</p> <p>4-010(1), Table 11</p> <p>Table 12</p>
3.2.9	<p>Wire bending space at field wiring terminals</p> <p>There shall be adequate room in a wiring compartment to properly make the field connections.</p> <p>Not applicable to wiring compartments for non-detachable power supply cords.</p>	373-6	C22.2 No. 0.12
3.2.9	<p>Volume of field wiring compartments</p> <p>Wiring compartments shall be of sufficient size to provide free space for all conductors enclosed in the box.</p> <p>Not applicable to wiring compartments for non-detachable power supply cords</p> <p>For certain locations, such as some Restricted Access Locations using low voltage d.c. systems, open wiring systems may be permitted. Equipment intended solely for installation in such locations need not be provided with a field wiring compartment. However, adequate free space shall be provided for all conductors, and all conductors shall be protected against accidental contact.</p>	370-16	12-3038 and Table 22 CSA C22.2 No. 0.12
3.3 (1.7.7) (2.6.4.1)	<p>Identification of the protective earthing terminal (terminal for the connection of the equipment grounding conductor or bonding conductor) for permanently connected equipment</p> <p>See 1.7.7 (2.6.4.1) (3.3).</p>	250-126	
3.3 (4.5.1)	<p>Temperature markings for field wiring compartments</p> <p>If the wires in a terminal box or compartment intended for power supply connection of equipment can attain a temperature higher than 60 °C during normal operation, the unit shall be marked near the point at which the supply connections are made with the minimum temperature rating of the conductors that must be used.</p>	110-14(c), 310-10	12-100(c) Individual CSA Part II Standards
3.3	Wiring terminals for field wiring connections		CSA C22.2 No. 0
3.3	<p>Wiring terminals for the connection of external conductors</p> <p>Field wiring terminals provided for interconnection of units by conductors not supplied by a limited power source, or a Class 2 circuit defined in the National Electrical Code, ANSI/NFPA 70, or the Canadian Electrical Code, CSA C22.1, also shall comply with the applicable requirements in 3.3.</p>	300-1 725	CSA C22.1

Annex NAE Continued

D1

Clause No.	Topic/summary	NEC	CEC
	Interconnection of units by conductors supplied by a Limited Power Source, or a Class 2 circuit defined in the National Electrical Code, ANSI/NFPA 70, or the Canadian Electrical Code, CSA C22.1, may have field wiring connections other than specified in 3.3 such as wire-wrap and crimp-on types, if the Limited Power Source and Class 2 circuits are separated from all other circuits by barriers, routing or fixing.		
3.3.1	Identification of terminals for connection of an earthed (grounded) conductor (neutral) Terminals for the connection of the earthed (grounded) circuit conductor (neutral) are required to be identified by a distinctive white marking or other equally effective means.	200-9 200-10(e)	26-002 CSA C22.2 No. 0.4
3.3.3	Wire-binding screws A wire-binding screw may be employed at a wiring terminal intended for connection of a No. 10 AWG (5,3 mm ²) or smaller conductor wire. Upturned lugs, a cupped washer or the equivalent shall be provided to hold the wire in position.	110-14(a)	12-116
3.3.4, Table 3D	Range of conductor sizes to be accepted by field wiring terminals Terminals must be suitable for the wire gauges commonly used in the U.S. and Canada. It is required that current-carrying conductors be rated 125 percent of the equipment rating. Therefore, once the equipment rating exceeds 80 percent of the capacity of the wiring in the branch circuit, the next higher capacity wire gauge must be used. Refer to the appropriate article in the National Electrical Code, ANSI/NFPA 70, and the Canadian Electrical Code, Part I, C22.1, for ampacity tables. The range of conductor sizes for earthing conductors (equipment grounding or bonding conductors) is specified elsewhere.	210-19(a), 210-20, 210-22(c) Article 310, ampacity tables 250-122(a), Table 250-122	4-004 Tables 1.C, 5C and 12
3.3.4 Table 3D (2.6.4.1)	Range of earthing conductor (equipment grounding conductor or bonding conductor) sizes to be accepted by field wiring terminals See 2.6.4.1 (3.3.4, Table 3D).		10-814 Table 16
3.3.6	Conductor material markings for field wiring terminals intended for aluminum conductors Equipment with supply field wiring terminals intended to be connected to aluminum conductors shall be so identified for the connection of aluminum conductors. This marking shall be independent of all other markings on the terminal connectors and shall be visible after installation.	110-14	12-118 The terminal for the connection of an equipment protective earthing (grounding) conductor shall not be identified for the connection of an aluminum conductor.
3.3.6	Terminals for field wiring Field wiring connections shall be made through the use of suitable pressure connectors (including set-screw type), solder lugs or splices to flexible leads.	110-14	12-116 12-118

Annex NAE Continued

D1

Clause No.	Topic/summary	NEC	CEC
3.4.2	<p>Motor control devices</p> <p>For cord-connected equipment provided with a motor that has a nominal voltage rating greater than 120 V, or that is rated greater than 1/3 hp (locked-rotor current over 43 A), and for motor-operated, cord-connected equipment rated more than 12 A, the plug on the power supply cord is not sufficient to serve as a disconnect device. A separate motor control device is required. Although a motor control device is required, the motor control device need not have a 3 mm contact gap if the equipment is provided with a separate suitable disconnect device (such as the plug on a power supply cord).</p>	430-81(c)	28-500(3)
3.4.8	<p>Orientation of switches and circuit breakers</p> <p>Vertically mounted disconnect switches and circuit breakers shall be mounted such that the up position of the handle is the "on" position.</p>	240-81	14-300 14-502
3.4.10	<p>Battery circuits</p> <p>For computer room applications, batteries integral to equipment shall incorporate a means for battery disconnect and a means for connection to the remote emergency power off circuit that disconnects the battery power source, except for battery circuits for which (1) the product of the open circuit voltage times the rating of the overcurrent protective device does not exceed 750 VA or (2) any resistive load cannot draw more than 750 VA for more than five minutes after the mains power is disconnected. If connection to the remote emergency power off circuit is required, batteries shall be disconnected within five minutes of activating the remote emergency power off circuit.</p>	645-11	14-700
3.6 (3.2.1)	<p>Connections to a d.c. power system (d.c. branch circuit)</p> <p>Connections to the d.c. power system shall meet the requirements for connection to branch circuits. (See connections to primary power, clause 3.2.)</p>	480-3	
3.6 (2.6.1)	<p>Earthing (grounding) of d.c. powered equipment</p> <p>Equipment intended to be connected to a nominal 48 V d.c. (or higher) power supply source, or systems rated less than 48 V d.c. that have one point directly earthed (grounded), shall have provision for the earthing (grounding) of all exposed dead metal parts that might become energized from the power supply source or from circuits involving a risk of electric shock.</p>	250-1, 250-2 480-4	See 2.5.1 10-102 10-104 10-202 10-404 10-810
3.6 (1.7.11) (2.7)	<p>Overcurrent and earth (ground) fault protection for d.c. powered equipment</p> <p>Overcurrent and earth (ground) fault protection in accordance with 2.7 shall be provided either in the equipment or as part of the building installation. If the protection is provided as part of the building installation, the type and rating shall be provided in the installation instructions. See also 1.7.11.</p> <p>If a protective device interrupts the neutral conductor, it shall also interrupt the supply conductor.</p>	422-11 240-22	 14-016
3.6 (1.7.2) (3.2.1)	<p>Polarity marking for d.c. powered equipment field wiring terminals</p> <p>Terminals and leads provided for permanent connection to the supply shall be marked to indicate polarity if reverse polarity may result in a hazard.</p>	200-10, 200-11	2-100(1)(m) Individual CSA Part II Standards

Annex NAE Continued

D1

Clause No.	Topic/summary	NEC	CEC
3.6 (2.5)	<p>Special earthing (grounding) conditions for d.c. powered equipment</p> <p>Equipment that has the earthed terminal (terminal for the grounded conductor) of the power source connected to the frame of the unit is required to have special provisions for earthing (grounding), along with markings and instructions. See annex NAA.</p> <p>If the equipment provides the means for connecting the supply to the earthing electrode conductor (grounding conductor or grounding electrode conductor), there shall be no switches or overcurrent protective devices located between the point of connection to the supply and the point of connection to the earthing (grounding) electrode.</p>	250-130 through 250-148, 250-160 through 250-169, 250-50, 250-62, 250-68, 250-91	10-102 10-104 10-202 10-404 10-810
4.3.12	<p>Maximum quantity of flammable liquid stored in equipment</p> <p>The maximum quantity of flammable liquid stored in equipment shall comply with table NAE.7</p>	ANSI/NFPA 30	
4.3.13	<p>Requirements for equipment incorporating lasers</p> <p>Requirements for lasers are contained in the applicable national codes and regulations</p>	Code of Federal Regulations; 21 CFR 1040	Canadian Radiation Emitting Devices Act, REDR C1370
4.5.1 (3.3)	<p>Temperature markings for field wiring compartments</p> <p>See 3.3 (4.5.1).</p>		Individual CSA Part II Standards
4.7.1	<p>Automated information storage equipment</p> <p>For computer room applications, automated information storage equipment, which is enclosed storage and retrieval equipment that moves recorded media between storage and electronic computer equipment, that is intended to contain more than 0,76 m³ of combustible media shall have provision for either automatic sprinklers or a gaseous agent extinguishing system with an extended discharge.</p>	NFPA 75	
4.7.3	<p>Equipment for use in environmental air space</p> <p>Equipment intended for use in environmental air space, other than air ducts or plenums, is required to be provided with a metal enclosure or with a non-metallic enclosure having adequate fire-resistance and low smoke-producing characteristics. Determination of low-smoke-producing characteristics is made in accordance with the Standard for Fire Tests for Heat and Visible Smoke Release for Discrete Products and Their Accessories Installed in Air-Handling Spaces, UL 2043.</p> <p>Equipment is not permitted to be installed in air ducts or plenums used for environmental air.</p>	300-22(c) 300-22(b)	12-010 12-010

Annex NAE Continued

D1

Clause No.	Topic/summary	NEC	CEC
4.7.3.1	<p>Flammability requirements for large surfaces</p> <p>For computer room applications, an external surface of combustible material having an exposed area of greater than 0,9 m² (10 sq ft) or a single dimension greater than 1,80 m (6 ft) shall have a flame spread rating of 50 or less when tested in accordance with either:</p> <ul style="list-style-type: none"> – the Standard for Tests for Surface Burning Characteristics of Building Materials, UL 723, or ASTM E84; or, – the radiant panel furnace method in ASTM E162. The flame spread rating as determined by this method is the average value based on tests of six samples representative of the wall thickness used, with no single sample rating greater than 75. <p>The limits mentioned refer to the exposed surface area of a single unbroken section. If two sides of a single piece are exposed, only the larger side is to be considered in computing the area.</p> <p>A material with a flame spread rating higher than 50 may be used as the exterior finish or covering on any portion of the enclosure, guard or cabinet if the flame spread rating of the combination of the base material and finish or covering complies with the flame spread requirements.</p> <p>For equipment not intended for use in computer rooms, materials with a flame spread rating of 200 or less may be used.</p>	NFPA 75	
Annex H	<p>Ionizing radiation</p> <p>In addition to measurement of ionizing radiation during normal operation in accordance with Annex H, measurements are made with the equipment operating under the following abnormal operating conditions, as applicable:</p> <ul style="list-style-type: none"> – a maximum supply voltage of 130 V if the equipment has a nominal voltage rating between 110 V and 120 V; – a maximum supply voltage of 110 % of the equipment nominal if the nominal is not between 110 V and 120 V; – under conditions identical to those which result from that component or circuit malfunction which maximizes x-radiation while maintaining the equipment operative for normal use. 	21 Code of Federal Regulations (CFR), Part 1020, Section 1020.10	Canadian Radiation Emitting Devices Act, REDR C1370

Table NAE.1
Circuit and cable types permitted by the National Electrical Code, ANSI/NFPA 70
(see 1.5.5)

D1
D1
D1

Circuit Type	Cable Type ^a
Class 2 or Limited Power	CL2
Class 3	CL3
TNV	CM
Optical	OFC, OFN
CATV	CATV

^a Substitution tables in the National Electrical Code, ANSI/NFPA 70, apply.

Table NAE.2
Conduit sizes and fill (3.2.2)

D1
D1

Type	Minimum size inch	Maximum size inch	NEC	CEC
Intermediate metal conduit	1/2	4	345-6 345-7, Chapter 9, Table 1	– –
Electrical metallic tubing (EMT)	1/2	4	348-7 348-8, Chapter 9, Table 1	12-1400 12-1408, Tables 6 and 8
Flexible metallic tubing	1/2 (3/8 for special cases)	3/4	349-10	–
	1/2		349-12, Chapter 9, Table 1	–
	3/8		Table 350-12	
Flexible metal conduit	1/2 (3/8 for special cases)	4	350-10	12-1004
	1/2		350-12, Chapter 9, Table 1	12-1004, 12-1014,
	3/8		Table 350-12	Tables 6 and 8
Liquid tight flexible metal conduit	1/2 (3/8 for special cases)	4	351-5	12-1300
	1/2		351-6	Table 8, 12-1304
	3/8		Chapter 9, Table 1, Table 350-12	
Liquid tight flexible nonmetallic conduit	1/2 (3/8 for special cases)	4	351-24	12-1300
	1/2		351-25	12-1014, Tables 6 and 8
	3/8		Chapter 9, Table 1, Table 350-3	
Rigid metal conduit	1/2	6	346-6, 346-7, Chapter 9, Table 1	12-1004 12-1014, Tables 6 and 8
			347-10	12-1100 12-1150 12-1200
Rigid nonmetallic conduit	1/2	6	347-11, Chapter 9, Table 1	12-1014, Tables 6 and 8

Table NAE.3
Conduit and knockout sizes
(3.2.2)

D1
D1
D1

Conduit trade size	Internal diameter inches	Nominal knockout diameter inches
1/2	0,622	7/8
3/4	0,824	1-3/32
1	1,049	1-23/64
1-1/4	1,380	1-23/32
1-1/2	1,610	1-31/32
2	2,067	2-15/32
2-1/2	2,469	3
3	3,068	3-5/8
3-1/2	3,548	4-1/8
4	4,026	4-5/8
4-1/2	4,506	5-1/8
5	5,047	5-5/8
6	6,065	6-3/4

Table NAE.4
Power supply cords (3.2.4)

D1
D1

Type of appliance	Type of cord
Table-model equipment (for use on a table, desk, counter and the like)	SV, SVE, SVO, SVOO, SVT, SVTO, SVTOO SP-2, SPE-2, SPT-2, NISP-2, NISPE-2, NISPT-2 SP-3, SPE-3, SPT-3
Table-model equipment (for use on a table, desk, counter and the like) that is subject to being moved frequently	SV, SVE, SVO, SVOO, SVT, SVTO, SVTOO SP-2, SPE-2, SPT-2, NISP-2, NISPE-2, NISPT-2
Hand-held equipment	TS, TST ^a SV, SVE, SVO, SVOO, SVT, SVTO, SVTOO ^b
Wall-mounted or floor-mounted equipment	SV, SVE, SVO, SVOO, SVT, SVTO, SVTOO ^c SP-2, SPE-2, SPT-2, NISP-2, NISPE-2, NISPT-2 ^c SP-3, SPE-3, SPT-3 ^c SJ, SJE, SJO, SJOO, SJT, SJTO, SJTOO S, SE, SO, SOO, ST, STO, STOO
^a A tinsel cord is acceptable if all of the following conditions are met: <ol style="list-style-type: none"> 1. The cord is not longer than 2,4 m. 2. The cord is attached to the equipment directly or by means of a plug which is intended for that purpose. 3. The equipment rating does not exceed 50 W. 4. The nature of the appliance will necessitate the use of an extremely flexible cord. 	
^b Type SV and similar cords are acceptable if each conductor is made up of 0,01 mm ² strands.	
^c Types SP-2, SP-3, SV and similar cords may be provided if the cord is not longer than 2,4 m.	

Table NAE.5
Allowable ampacity for flexible cords and cables
(Based on ambient temperature of 30°C)
(Extracted from the NEC)

D1
D1
D1
D1

Size AWG	Thermoset type	Thermoset types		Types
	TS	C, E, EO, PD S, SJ, SJO, SJOO, SO, SOO, SP-1, SP-2, SP-3, SRD, SV, SVO, SVOO		
	Thermoplastic types	Thermoplastic types		
	TPT, TST	ET, ETLB, ETT, SE, SEO, SJE, SJEO, SJT, SJTO, SJTOO, SPE-1, SPE-2, SPE-3, SPT-1, SPT-2, SPT-3, ST, SRDE, SRDT, STO, STOO, SVE, SVEO, SVT, SVTO, SVTOO		
		A ^a	B ^a	
27 ^b	0,5	–	–	–
30	–	5 ^c	7 ^c	–
18	–	7	10	10
17	–	–	12	–
16	–	10	13	15
15	–	–	–	17
14	–	15	18	20
12	–	20	25	30
10	–	25	30	35
8	–	35	40	–
6	–	45	55	–
4	–	60	70	–
2	–	80	95	–
<p>^a The allowable currents under subheading A apply to 3-conductor cords and other multi-conductor cords connected to utilization equipment so that only 3 conductors are current-carrying. The allowable currents under subheading B apply to 2-conductor cords and other multi-conductor cords connected to utilization equipment so that only 2 conductors are current-carrying.</p> <p>^b Tinsel cord.</p> <p>^c Elevator cables only; 2 amperes for other types.</p>				

Table NAE.6
Allowable ampacity of flexible cord and equipment wire
(Based on ambient temperature of 30°C)
(Extracted from the NEC)

D1
D1
D1
D1

Size AWG	Allowable ampacity								
	Flexible cord						Equipment wire		
	Tinsel cords	Christ- mas tree cord	Elevator cable		Types PXWT, SV, SVO, SVOO, SJ ^a , SJO ^a , SJO ^a , SJOW, SJOOW, S ^a , SO ^a , SOO ^a , SOW, SOOW, SPT-1, SPT-2, SPT-3, SVT ^b , SVTO ^b _v , SVTOO ^b , SJT ^a , SJTO ^a , SJTOO ^a , ST ^a , STO ^a , STOO ^a , SJTW, SJTOW, SJTOOW, STW, STOW, STOOW		Types HSJO ^a , HPN, DRT	Types TXF, TXFW	Types GTF ^c , TEW ^c , SEW ^c , REW ^c , TEWN ^c , SEWF ^c , TBS ^c , SIS ^c
					Type TPT, TST	Type CXWT			
27	0,5	-	-	-	-	-	-	-	-
26	-	-	-	-	-	-	-	-	1
24	-	-	-	-	-	-	-	-	2
22	-	-	-	-	-	-	-	-	3
20	-	-	2	-	2	-	-	2	4
18	-	5	-	5	10	7	10	5	6
16	-	7	-	7	13	10	15	7	8
14	-	-	-	15	18	15	20	-	17
12	-	-	-	20	25	20	25	-	23
10	-	-	-	25	30	25	30 ^d	-	28
8	-	-	-	35	40	35	40 ^d	-	40
6	-	-	-	45	55	45	50 ^d	-	55
4	-	-	-	60	70	60	60 ^d	-	70
3	-	-	-	-	-	-	-	-	80
2	-	-	-	80	95	80	-	-	95
1	-	-	-	-	-	-	-	-	110
1/0	-	-	-	-	-	-	-	-	125
2/0	-	-	-	-	-	-	-	-	145
3/0	-	-	-	-	-	-	-	-	165
4/0	-	-	-	-	-	-	-	-	195
NOTES									

Table NAE.6 Continued

D1

Size AWG	Allowable ampacity						
	Flexible cord					Equipment wire	
	Tinsel cords	Christ- mas tree cord	Elevator cable		Types PXWT, SV, SVO, SVOO, SJ ^a , SJO ^a , SJOO ^a , SJOW, SJOOW, S ^a , SO ^a , SOO ^a , SOW, SOOW, SPT-1, SPT-2, SPT-3, SVT ^b , SVTO ^{b,v} , SVTOO ^b , SJT ^a , SJTO ^a , SJTOO ^a , ST ^a , STO ^a , STOO ^a , SJTW, SJTOW, SJTOOW, STW, STOW, STOOW	Types HSJO ^a , HPN, DRT	Types TXF, TXFW
Types TPT, TST	Type CXWT	Type PXT	Types E, EO, ETT, ETP	2 Current- carrying con- ductors			

1 It is intended that this table be used in conjunction with applicable end-use product standards to ensure selection of the proper size and type.

2 TXF is recognized in No. 20 AWG only. TXFW is recognized in size No. 16 and 18 AWG.

a Types HSJO, SJ, SJO, SJOO, SJT, SJTO, SJTOO, S, SO, SOO, ST, STO and STOO flexible cords are now recognized only as components of equipment.

b Type SVT, SVTO, SVTOO, SV, SVO and SVOO 2 conductor No. 17 AWG is recognized with an ampacity of 12 A as a component of vacuum cleaners with retractable power supply cords.

c The derating factors of Rule 4-014(1)(b), (c), (d) and (e) of the Canadian Electrical Code, Part I, C22.1, are to be applied to these values for the types listed in this column.

d These current ratings are for Type DRT household dryer and range cables only.

Table NAE.7
Maximum quantity of flammable liquid stored in equipment

D1
D1

Liquid		Closed storage container	
Flash point °C	Boiling point °C	Material	Size liters
Below 22,8	Below 37,8	Shall not be used	
Below 22,8	Above 37,8	Glass	0,95
		Metal or plastic	18,90
At or above 22,8 and below 60	–	Glass	3,79
		Metal or plastic	18,90
At or above 60	–	Glass	18,90
		Metal or plastic	18,90

1) FLAMMABLE LIQUIDS with flash points below 22,8 °C and boiling points below 37,8 °C may not be used or stored within equipment covered by the scope of this standard.

2) Individual reservoirs in equipment shall not be larger than the corresponding sizes for closed storage containers in this table.

INDEX

(informative)

This index is for information only and does not purport to be a complete guide to the use of the standard. The inclusion or omission of items in the index does not imply any particular importance.

Location references are clause or sub-clause numbers or annex letters.

Table numbers and figure numbers are linked to the clause or annex in which they are found. For example, table 2A is the first table in clause 2, and figure F.2 is the second figure in annex F.

Principal references are printed **Bold**.

If a term is defined in 1.2 of the standard, its definition is indicated in the index by an asterisk, for example: **RATED VOLTAGE 1.2.1.1***.

This index is also used to explain some acronyms, for example: EUT equipment under test.

Country notes are listed, but the contents are not indexed.

A

abnormal conditions, 0.1, 1.3.2

 heating elements, 4.3.7

 overload protection, 5.3.1, 5.3.3

 sequence of testing, 1.4.3

 simulated, 5.3.6

 fan not running, 4.3.12

 general, 4.7.1

 one at a time, 1.4.14

 tests under abnormal conditions of

 electrical components, 5.3.6

 electromechanical components, 5.3.5

 heating thermoplastic parts, 4.5.2

 motors, 5.3.2, annex B

 thermostats, K.6

thermal cut-out operates , 1.2.11.3

within FIRE ENCLOSURES, 4.7.3.2

abnormal operating conditions, *see* abnormal conditions

abrasion resistance test, **2.10.6.6**, 2.10.9

A.C. MAINS SUPPLIES, 1.2.8.1*, 1.7.1

capacitors, 1.5.6, 2.1.1.7

connections, **3.2**, 5.1.2

equivalent sources, 1.2.8.1, 1.4.5

for limited power sources, 2.5

frequency, 1.4.7

isolation, *see* disconnection

neutral, 3.4.6, 3.4.7

terminals, 1.7.7.2, 3.3

see also mains, PRIMARY CIRCUITS

a.c. power distribution systems

see power distribution systems, a.c.

access, accessibility

by

OPERATORS *see* OPERATOR ACCESS AREAS

SERVICE PERSONNEL *see* SERVICE ACCESS AREAS

definitions, **1.2.7***

means OPERATOR access (area), 1.2.7.1

prevention by interlocks, *see* safety interlocks

restricted, 1.2.6.4, 1.2.8.9, 2.1.1

through openings in ENCLOSURES, 2.1.1.1, annex F (figure F.12, point A)

to

connectors, by SERVICE PERSONNEL, 4.3.5

connector shells, 2.1.1.1

controls, 4.3.3

energized parts, 0.1, **2.1.1**

ELV CIRCUITS *see* ELV CIRCUITS, accessibility

handles, levers, knobs, 2.1.1.6

interlocks, 2.8.3, 2.8.6

internal wiring, 2.1.1.3, 2.1.1.4

laser radiation, 4.3.13, annex P (IEC 60825-1)

plugs and sockets, by SERVICE PERSONNEL, 4.3.5

moving parts, 2.8.2, 4.4

sharp edges, 4.3.1

TELECOMMUNICATION NETWORKS, 6.2.1

terminals in supply wiring space, 3.2.9

TNV CIRCUITS *see* TNV CIRCUITS, accessibility

with a tool, 1.7.16

see also RESTRICTED ACCESS LOCATIONS

accessibility *see* access

actuators, mechanical, in interlock systems , 2.8.5, 2.8.8

acoustic noise hazard, 0.2.6

additional requirements to those in the standard, 1.1.2

adhesive

ageing test, 4.6.5

application, 2.10.7 (note), 4.3.2

foil, 5.1.4, 5.2.2, 6.2.2

tape, as insulating material, 4.7.3.4

adjustment

marking

for rated voltage, 1.7.4

for thermostats etc., 1.7.11

must not create a hazard, 4.3.3

worst case conditions for tests, 1.4.4, 1.4.10, 2.1.1.1, 4.3.8, annex H

air gaps

behind conductive ENCLOSURES, 2.10.3.1, 4.2.1, G.6

CLEARANCES applicable, 2.10.3.1, G.6

CLEARANCES not applicable, 2.6.1 (note), 2.10.3.1, G.6

disconnect devices, 3.4.2

interlock switches, 2.8.7.1

tip of test finger if voltage is over 1 kV, 2.1.1.1, annex F (figure F.12 point A)

altitude (elevation) during operation, 0.1, 1.1.2, G.6

ampacity of

INTERCONNECTING CABLES, 3.1.1

internal wiring, 3.1.1

power supply cords, 3.2.5

PROTECTIVE BONDING CONDUCTORS, 2.6.3.2

for SELV CIRCUITS, 2.2.3.3

PROTECTIVE EARTHING CONDUCTORS, 2.6.3.1

telecommunication wiring, 6.3

wiring terminals , 2.6.4.1, 3.3.4, 3.3.5

apertures *see* openings

appliance couplers, annex P (IEC 60320)

as disconnect devices *see* disconnection for servicing

as means of connection to earth, 2.6.5.4

as means of connection to power, 3.2.1

fault testing, 5.3.6

in PLUGGABLE EQUIPMENT, 1.2.5.1, 1.2.5.2

on detachable power supply cords, 1.2.5.4, 3.2.5 (note 1)

reversible (unpolarized), 3.4.6 (note), 4.3.7

that fill apertures in ENCLOSURES, 4.7.3.2

appliance inlets, **3.2.4**

earthing terminals, 2.6.4.1, 2.6.4.2

see also appliance couplers

applicability

of requirements, 1.3.1

of this standard, 1.1.1

of tests, 1.4.1, 1.5.2

arcing

as energy hazard, 0.2.2

causing ignition of air filter, 4.7.3.5

high current ignition tests, 4.7.3.2, A.3

in FIRE ENCLOSURE, 4.7.2.1, 4.7.3.2

asbestos, not to be used as insulation, 2.9.1

attitude (orientation), 1.3.6

AWG (American wire gage), 2.6.3.2 (table 2D), 3.2.5 (table 3B)

B

backup

overcurrent protection, 2.7.3

sources of power see multiple power sources

baffles in bottoms of FIRE ENCLOSURES, 4.6.2

ball pressure test on thermoplastic parts, 4.5.2

bandwidth of measuring instruments, 1.4.7

barriers, 0.2.3

for electrical separation , 2.2.3.1

for power connections, 3.1.9

in bottoms of FIRE ENCLOSURES, 4.6.2

in TRANSPORTABLE EQUIPMENT, 4.6.4

no mechanical strength test within MECHANICAL ENCLOSURE, 4.2.1

secured with adhesive, 4.6.5

to prevent ignition, 4.6.2, 4.7.3.1, 4.7.3.4, 4.7.3.5

BASIC INSULATION, 0.2.1, 1.2.9.2*, 1.2.9.3, 1.2.9.4, 1.2.9.5 (note)

application, 2.1.1, 2.1.1.1, 2.9.5

in

ELV CIRCUITS, 1.2.8.5, 2.1.1.3

FUNCTIONAL EARTHING circuits, 2.6.2

SELV CIRCUITS, 2.2.1, 2.2.3.2, 2.2.3.3, 2.2.4

TNV CIRCUITS, 2.3.2, 2.3.3, 2.3.4

wound components, 2.10.5.4

on coated printed boards, 2.10.6, annex F (figure F.11)

bridging *see* bridging of insulation

consequences of failure, 2.2.1, 2.2.3, 2.3.2, 2.4.1, 2.6.1

dimensions, **2.10.3**, **2.10.4**, **2.10.5**, annexes F and **G**, R.1, R.2

electric strength, **5.2**

failure to be simulated, 1.4.14

integrity

after a test , 5.3.4, 5.3.8.2

in service, 3.3.8

interchanged with SUPPLEMENTARY INSULATION, 2.9.5

one element of DOUBLE INSULATION, 2.10.2, 5.3.8.2

short-circuited before test, 2.3.2

WORKING VOLTAGES, 2.10.2

batteries

as SECONDARY CIRCUITS, 1.2.8.3

in limited power sources, 2.5

replaceable, 1.7.15, 4.3.8

requirements, **4.3.8**

battery backup systems, not in Scope of standard, 1.1.3

battery compartments, access to TNV CIRCUITS, 2.1.1.2

beads, ceramic, 3.1.5

OPERATOR access , 2.1.1.1 (note 1)

belts, 2.1.1.1, 2.9.1, 4.7.3.3, 4.7.3.4, A.6.1

bibliography, annex Q

BODY (of equipment), 1.2.7.5*

conductive, 1.6.4, 2.9.5 (note to table 2G), 5.1.3, 5.2.2 (table 5B part 1)

body, current through a human, 0.2.1, 5.1.6 (note), annex Q (IEC 60479-1), annex W

see also TOUCH CURRENT

bonding *see* PROTECTIVE BONDING CONDUCTORS *and*

protective earthing and bonding

BOUNDING SURFACES, 1.2.10.1, 1.2.10.2, 1.2.10.3*

breakdown (of insulation) *see* failures (of insulation)

bridging of insulation, 1.5.7, 2.9.5, 6.1.2.1

by

capacitors, 1.5.6, 1.5.7.1, 1.5.8, 5.2.2 (note 2)

conductive objects, 4.6.4, C.2

resistors, 1.5.7.2, 5.2.2 (note 3)

surge suppressors , 6.1.2.1

components removed for test , 5.2.1, 6.1.2.1

in TRANSPORTABLE EQUIPMENT, 4.6.4

permitted with conditions, 1.5.7, 2.2.4, 2.3.4, 2.4.3

under fault conditions, 3.1.6, 3.3.8, C.2

see also energy hazards *and*

short-circuits of insulation for test

building installations (fixed wiring), ~~1.2.3.10~~ 1.2.13.10, 1.2.5.1, 1.2.5.2, 1.2.5.3, 2.7.4

DE

see also IEC 30364

disconnect device in, 1.7.2, 3.4.3, 3.4.6, 3.4.7

not in Scope of standard, 1.1.3

protective device in, 2.7.1, 2.7.3, 2.7.4 (note 2)

special earthing requirements, annex Q (IEC 364-7-707)

building wiring *see* building installations

BUILDING-IN, EQUIPMENT FOR, 1.2.3.5*, 2.1.1.1, 4.5.1

burn hazard, 0.2.1, 0.2.2, 0.2.4

see also flammability

bus-bars

as internal wiring, 3.1.1

AS PROTECTIVE EARTHING CONDUCTORS, 2.6.3.4

bushings

in metal, 3.1.2

power cord, 3.2.7, 3.2.8

business equipment, 1.1.1

normal load conditions, annex L

C

cables

earthing conductors, colour of insulation, 2.6.2, 2.6.3.4

FIRE ENCLOSURES not required, 4.7.2.2

power, 3.3.4, 3.3.5, annex P (IEC 60227, IEC 60245, IEC 60885-1)

telecommunication, 6.3 (note 2)

television distribution, 1.2.13.8

CABLES, INTERCONNECTING, 1.2.8.2, 1.2.11.6*, **1.5.5**, 3.1.1, 3.5.1 (note 2)

calibre of conductors *see* ampacity

capacitors

class X (IEC 60384-14), 1.5.6

class Y (IEC 60384-14), 1.5.6, 1.5.7.1, 1.5.8

connected to IT power distribution systems, 1.5.8

IEC 60065, 4.7.3.6

in filters, 1.5.6, 1.5.8, 5.2.2 (notes 2 and 3)

 discharging, 2.1.1.7

in FIRE ENCLOSURES, 4.7.3.4

motor, B.5, B.8

not protected by fuses, 5.3.7

stored charge, 2.1.1.7, 2.4.2

cathode ray tubes, mechanical strength, 0.2.5, 4.2.1, 4.2.8

CCITT Recommendations *see* ITU-T Recommendations

ceiling-mounted equipment, 4.2.10

cemented joints

 in insulation, 2.10.8, figures F.5, F.6 and F.7

 in winding wire, 2.10.5.4

ceramic and glass insulation

 CREEPAGE DISTANCES, 2.10.4

 flammability, no test, 4.7

 on printed boards, 2.10.5.3 (table 2M)

 temperature during tests , 4.5.1 (table 4A part 2), 5.3.8.1

see also beads, ceramic

CFR 47, part 68, M.3 (note), annex Q

chemical hazards, 0.2.7

in batteries, 4.3.8

ozone, 1.7.2

see also corrosion

circuit characteristics (definitions), 1.2.8*

circuits

interconnection, 3.5.1, 3.5.2

ELV *see* ELV CIRCUITS

LIMITED CURRENT *see* LIMITED CURRENT CIRCUITS

PRIMARY *see* PRIMARY CIRCUITS

SECONDARY *see* SECONDARY CIRCUITS

SELV *see* SELV CIRCUITS

TNV *see* TNV CIRCUITS

classification of equipment

(protection against electric shock), 1.2.4

CLASS I EQUIPMENT, 1.2.4.1*, 1.7.2 (note 4), 5.3.8.2, W.1

CLASS II EQUIPMENT, 1.2.4.2*, 1.7.1, W.1

CLASS III EQUIPMENT, 1.2.4.3*

CLEARANCES, 1.2.10.1*, 2.10.1, **2.10.3.1**, annex F, **annex G**

as FUNCTIONAL INSULATION, 5.3.4

behind conductive ENCLOSURES, 4.2.1

divided by floating parts, 2.10.1, annex F (figure F.13)

in

encapsulated parts, 2.10.8

enclosed parts, 2.10.7

PRIMARY CIRCUITS, **2.10.3.2**, annex G

SECONDARY CIRCUITS, **2.10.3.3**, annex G

increased by coatings, 2.10.9

integrity in service, 2.10.1, C.2

measured through openings, 2.10.3.1, annex F (figure F.12 point B), G.6

must be adequate, 2.10.1

reduced, R.2

varying, 2.10.10

WORKING VOLTAGES, 2.10.2

see also IEC 60664, interpolation, TELECOMMUNICATION NETWORK TRANSIENT VOLTAGES, transients *and* separation distances

cmil *see* AWG

coated printed boards, **2.10.6**, annex F (figure F.11), R.1

colours

controls and indicators, 1.7.8.2, annex P (IEC 60073, ISO 3864)

flexible printed wiring, 2.6.3.4

FUNCTIONAL EARTHING conductors, 2.6.2

PROTECTIVE EARTHING CONDUCTORS, 2.6.3.4, 3.2.5

comparative tracking index (CTI) *see* tracking

components, 1.2.11*

bridging insulation *see* bridging of insulation

electro-mechanical, 2.8.4, 2.8.8, 5.3.5

high voltage, 4.7.3.6

selection, 0.3, **1.5.1**, 1.5.8, 4.7.1

separate testing, 1.4.3, 1.5.2, 4.5.1, 6.2.2

voltage rating, 1.5.8, 1.6.4

wound, 2.10.5.4, 5.3.5, annex U

see also capacitors, resistors, sealed components, semiconductor devices *and* transformers

conductive liquids *see* liquids, conductive

conductor sizes *see* ampacity

conductors *see* wires, wiring

connection terminals

see wiring terminals

connections

between circuits , 2.2.4, 2.3.4, 2.4.3

FUNCTIONAL EARTHING, 2.6.2

to

other equipment *see* interconnection of equipment

power supply, 1.2.5*, 1.4.10, 3.1, 3.2, 3.3, 5.1.2

protective earth, 2.6, 2.9.5

TELECOMMUNICATION NETWORKS, 1.1.1, 1.4.11, 2.2.2 (note), **clause 6**, annex Q (CFR 47, part 68)

see also disconnection *and* INTERCONNECTING CABLES

connectors

contact by test probe, 2.1.1.1, 6.2.1

flammability, 4.7.2.2, 4.7.3.3, 4.7.3.4

FIRE ENCLOSURES not required, 4.7.2.2

mismatching, not to create a hazard, 4.3.5

multiway, 3.1.9

power, **3.2**

protective earthing contacts in, 2.6.4.1, 2.6.5.3, 2.6.5.4

see also appliance couplers, appliance inlets, mains plugs *and* socket-outlets

construction

details, **4.3**

general requirements, 1.3.1, 1.3.2

not covered by the standard, 1.3.4

consumable supplies, 0.2.3, 0.2.7, 1.4.14, 4.7.3.2, 4.7.3.3, 4.7.3.4

contact

gaps *see* air gaps

pressure, 3.1.6, 3.1.7, 3.3.6

see also access

CONTINUOUS OPERATION, 1.2.2.3*, 4.5.1

control, quality *see* quality control

controls

manual

accessibility, 4.3.3

fixing, 4.3.2

isolation, 2.1.1.6

operated during test, 5.1.5, annex H

marking, 1.7.8

supply voltage adjustment, 1.7.4, 4.3.3

temperature, 4.5.1 (table 4A part 2)

thermal *see* thermal controls

see also colours

cord anchorages, power cord, **3.2.6**

cord guards, power cord, 3.2.7, **3.2.8**

integral with cord, 1.2.5.5

cords, telephone, 2.1.1.2 (note)

cords, power supply *see* power (supply) cords

corrosion

by consumable materials, 4.3.10

by environment, 1.1.2

in protective earthing connections, 2.6.5.6

country notes

general, 1.1.2, 1.2.13.10, 1.7.12, 3.2.3, 3.2.5 (table 3B), M.1

Australia, 1.6.1, 2.1, 3.2.3, 3.2.5, 4.3.6, 6.2.2, 6.2.2.1, 6.2.2.2

Austria, 6.2.2.1

Canada, 2.2.3, 2.3.2, 4.7.2.2, 4.7.3.1

CENELEC countries, 2.7.1

Denmark, 2.3.2, 2.3.3, 6.1.2.1

Germany, 1.7.12

Finland, 2.3.3, 2.3.4, 6.1.2.2

Norway, 1.5.8, 1.7.2, 2.2.4, 2.3.2, 2.3.3, 2.3.4, 2.10.3.1, 6.1.2.1, 6.1.2.2, G.2

Sweden, 1.7.2, 6.1.2.1

United Kingdom, 3.2.1

United States of America, 2.2.3, 2.3.2, 4.7.2.2, 4.7.3.1

coverings, protective, in place during tests, 5.3.1

covers

of components, no A.3 test, 4.7.3.2

of supply wiring space, 3.2.9

transparent, no mechanical strength test, 4.2.1

see also doors and covers

CREEPAGE DISTANCES, 1.2.10.2*, 2.10.1, **2.10.4, annex F**

AS FUNCTIONAL INSULATION, 5.3.4

divided by floating parts, 2.10.1, annex F (figure F.13)

in encapsulated parts, 2.10.8

in enclosed parts, 2.10.7

increased by coatings, 2.10.9

integrity in service, C.2

measured through openings, 2.10.4, annex F (figure F.12 point B)

must be adequate, 2.10.1

not less than CLEARANCES, 2.10.4

varying, 2.10.10

WORKING VOLTAGES, 2.10.2, 2.10.4

see also IEC 60664, interpolation, *and* separation distances

CTI (comparative tracking index) *see* tracking

current

in human body, 0.2.1, annex Q (IEC 60479-1)

input, determination, 1.4.10

input, maximum, 1.6.2

limiters, 2.5

locked rotor, B.1, B.5

maximum ringing signal, M.2, M.3

r.m.s. value implied unless otherwise specified, 1.2

to telecommunication wiring, 6.3

see also PROTECTIVE CONDUCTOR CURRENT, TOUCH CURRENT *and* RATED CURRENT

current-carrying capacity *see* ampacity

cut-outs, thermal *see* thermal cut-outs

D

d.c. component of waveform, 1.4.7, 2.3.1

see also ripple

d.c. current for tests , 2.6.3.3

d.c. power supply, 1.4.5, 1.7.1, 2.6.3.3, 5.2.2 (table 5B, items 2 to 5)

d.c. motors, testing, B.1, B.6, B.7, B.10

DC VOLTAGE, 0.2.1, 1.2.13.4*

for tests, instead of a.c., 5.2.2, 6.2.2.2, 6.2.2.3, annex R

testing capacitors, 5.2.2 (note 2)

see also ripple

DECORATIVE PARTS, 1.2.6.5*, 4.7.3.3

see also ENCLOSURES

definitions, **1.2**

miscellaneous, 1.2.13

design, general requirements, 1.3, 4.3, 5.3.1

DETACHABLE POWER SUPPLY CORDS *see* power (supply) cords

different criteria and tests in the standard,

manufacturer's choice, 1.3.7

DIRECT PLUG-IN EQUIPMENT, 1.2.3.6*, 3.2.1, 3.4.2, 4.2.6, **4.3.6**

disconnection

automatic, 2.7, 4.3.7, 5.3.2

by interlocks, 2.8

for servicing (isolation), 3.4

disconnect devices, 3.4.2, 3.4.6, 3.4.7

appliance couplers, 2.6.5.4

heating elements, 4.3.7

in building installations, 1.7.2, 3.4.3, 3.4.6, 3.4.7

single phase, 3.4.6

switches, 3.4.5, ~~3.4~~ 3.4.8

DE

three-phase, 3.4.7

from A.C. MAINS SUPPLIES, **3.4**

heating elements, 4.3.7

from protective earth, 2.6.5.3, 2.6.5.5

from TELECOMMUNICATION NETWORKS, 2.1.1.2, 2.3.2

of components, during testing, 2.10.3.4, 5.1.5, 5.2.1, 5.2.2, ~~(note 3)~~, ~~5.2.3~~, 5.3.1, 6.2.2.2, 6.2.2.3, G.5 DE

multiple sources, marking, 1.7.9

distances through insulation, **2.10.5.1**, 2.10.8

ELV CIRCUITS, 2.1.1.3

printed boards, 2.10.5.3

varying, 2.10.10, 5.2.2

doors and covers, 4.2.3, 4.6.1, 4.6.3

access through, 2.1.1.2, 2.8.2, 2.8.3

marking on, 1.7.1

position during tests, 2.1.1.1, 4.1, 4.4.2, 4.6.4

DOUBLE INSULATION, 0.2.1, 1.2.9.4*, 1.2.9.5

application, 2.9.5

in

components, 2.2.3, 2.3.1, 2.4.1

FUNCTIONAL EARTHING circuits, 2.6.2

HAZARDOUS VOLTAGE circuits, 2.1.1.4

internal wiring, 2.1.1

manual controls, 2.1.1.6

printed boards, 2.10.6

SELV CIRCUITS 2.2.3.1, 2.2.4

TNV CIRCUITS 2.3.3, 2.3.4

wound components, 2.10.5.4, annex U

BASIC and SUPPLEMENTARY can be interchanged

bridging *see* bridging of insulation

care during electric strength tests, 5.2.2

dimensions *see* BASIC INSULATION *and* SUPPLEMENTARY INSULATION

integrity

after a test, 5.3.8.2

in service, 3.3.8

protective device not needed, 2.7.4

unearthed parts within, 2.9.5

WORKING VOLTAGES, 2.10.2

meaning, for DOUBLE INSULATION, 2.10.2

drop test, 4.2.1, 4.2.6

duty cycles, marking SHORT-TIME and INTERMITTENT, 1.7.3

dust

additional requirements if present, 1.1.2, **4.3.10**

explosion limit, 1.2.12.10

excluded in pollution degree 1, 2.10.1

E

earth, earthing, 0.2.1, **2.6**

a.c. power distribution systems, annex V

functional earthing, 1.2.13.9*, 2.6.2

protective *see*.protective bonding conductors, protective earthing and bonding,
protective earthing conductors *and* screens, conductive, earthed

permanent connection, 6.1.2.2

rises of potential, not to be considered, 1.4.8

voltage measurements to, 1.4.9

earth fault protection, **2.7**

see also overcurrent protection devices

earth leakage current *see* TOUCH CURRENT

electric shock, 0.2.1, 1.3.2

caused by

heat damage, 5.3.4

overload, 5.3.1

stored charge, 2.1.1.7

touching bare conductive parts, 2.1.1, 5.1

protection, 2.1

by insulation, 1.2.9

by interlocks, 2.8.2

by SELV CIRCUITS, 2.2

by TNV CIRCUITS, 2.3

two levels, 0.2.1

warning symbol, 1.7.16

electric strength tests, 5.2

not for verifying CLEARANCES, 2.10.3.1, annex G

used for verifying solid insulation, 2.10.5

with or without pre-heating, 5.2 (note), 5.2.1

WORKING VOLTAGES, 2.10.2

NOTE Electric strength tests are required in numerous places in the standard

ELECTRICAL ENCLOSURES, 1.2.6.4*, 2.1.1.1, 4.7.3.2, 4.7.3.3

see also ENCLOSURES *and* openings in ENCLOSURES

electrical filters

effect of, 2.10.3.4, G.4 a), G.5

electric strength tests, 5.2.2 (notes 2 and 3)

fault testing, 5.3.6

FUNCTIONAL EARTHING, 2.6.2

smaller CLEARANCES permitted, 2.10.3.2

three-phase, during TOUCH CURRENT testing, 5.1.5 (note)

electrochemical potentials, 2.6.5.6, annex J

electromechanical components, **5.3.5**

elevation *see* altitude

ELV CIRCUITS, 1.2.8.5*

accessibility, 2.1.1.1, 2.1.1.6, 3.2.2

in SERVICE ACCESS AREAS, 2.1.2

of insulation, 2.1.1.3

as interconnection circuits, 3.5.2, 3.5.3

insulation, 2.9.5

operating voltages, 1.4.8

reed switches in, 2.8.7.3

similar to SELV CIRCUITS, 2.2.3.3 (note 2)

e.m.c. *see* electrical filters

enamel, solvent-based, not suitable as safety insulation, 2.1.1.1(note 1), 2.10.5.2, 2.10.5.4, 2.10.8

encapsulated parts, 2.10.8

enclosed parts, 2.10.7

ENCLOSURES, 1.2.6.1*, 5.3.8.1

bottoms, 4.2.4, 4.2.5, 4.6.1, **4.6.2**, A.5

definitions, 1.2.6*

flammability, 4.7.3.2, 4.7.3.3, A.1, A.2, A.5

mechanical strength, 4.2, A.10

metallized plastic, in TRANSPORTABLE EQUIPMENT, 4.6.4

see also air gaps behind conductive ENCLOSURES, DECORATIVE PARTS, ELECTRICAL ENCLOSURES, FIRE ENCLOSURES, MECHANICAL ENCLOSURES, openings in ENCLOSURES, IEC 60529 and IEC 61032

endurance testing

interlock switches, 2.8.7.3

thermal controls, annex K

energy hazards, 0.2.2, 5.3.8.1

disconnection, 3.4.10

in

ENCLOSURES, 4.2.1, 4.6.1(note 1)

FIRE ENCLOSURES, 4.7.2.1

LIMITED CURRENT CIRCUITS, **2.4.2**

OPERATOR ACCESS AREAS, 2.1.1, **2.1.1.5**

RESTRICTED ACCESS LOCATIONS, **2.1.3**

SERVICE ACCESS AREAS, **2.1.2**

multiple sources, 1.7.9

reduced by interlocks, 2.8.2

ENERGY LEVELS, HAZARDOUS, 1.2.6.4, 1.2.8.8*

environment of equipment

manufacturing, R.1, R.2

special, 1.1.2

to be taken into account in design, 2.6.5.6, 2.9.1

see also humidity, pollution degree, temperature

equipment

electrical ratings (definitions), 1.2.1

not operational after a test, 1.4.1, 5.3.1

EQUIPMENT FOR BUILDING-IN, 1.2.3.5*, 2.1.1.1, 4.5.1

equivalent level of safety, 1.3.4

equivalent materials permitted, 1.3.5

equivalent sources of power, 1.2.8.1, 1.4.5

EUT equipment under test

examples given in the standard, others not excluded, 1.3.8

explosion

EXPLOSION LIMIT, 1.2.12.10*, 4.3.12

(implosion) of cathode ray tube, 0.2.5, 4.2.8

of battery, 1.7.15, 4.3.8

of high pressure lamp, 0.2.5, 4.2.9

F

failures, **5.3.1**

consequences, 1.3.1

of

components, 0.1, 0.2.3, 2.2.3, 2.3.1, 4.3.8, 5.3.6

in LIMITED CURRENT CIRCUITS, 2.4.3

in SELV CIRCUITS, 2.2.1, 2.2.4

in TNV CIRCUITS, 2.3.12.3.2, 2.3.4

ENCLOSURES, 4.2.5, 4.7

equipment to operate, evident to an OPERATOR, 5.3.5

insulation, 0.1, 0.2.3, 1.4.14, 2.2.3, 2.3.1, 2.4.3

motor capacitors, B.8

safety interlock systems, 2.8.4

screwed connections, 4.3.4

mechanical, 5.3.5

see also faults

fault conditions, 1.3.2

difference between ELV CIRCUITS and SELV CIRCUITS, 2.2.3.3 (note 2)

protection required, 2.7.1, 2.7.3, 2.7.4, 4.7.3.3, 4.7.3.4

fault current, 2.2.3.3, 2.7.3, 2.7.4

in protective earthing conductors, 2.6.1, 2.6.3

faults, 1.3.2

consequential, 0.1, 0.2.1, 1.4.14, 5.3.5

earth, 2.7.1, 2.7.4, 4.3.7

in

equipment earthed for safety purposes, 2.6.1

LIMITED CURRENT CIRCUITS, 1.2.8.7, 2.4.1

limited power sources, 2.5

power distribution systems, 1.2.13.8 (note 2), 1.4.8, annex V

protective earthing connections, 5.1.1

ringing signal circuits, M.2, M.3

SELV CIRCUITS, 1.2.8.6, 2.2

TNV CIRCUITS, 1.2.8.9, 2.3.1

not covered in 5.3, 2.7.2

simulated, 1.4.14, 2.3.4, 2.7.4, 5.3.5, **5.3.6**

single, 0.2.1, 1.4.14, 2.9.5

see also abnormal conditions *and* failures

FCC Rules, Part 68, M.3 (note), annex P

FEP (fluoro ethylene propylene), 4.7.2.2, 4.7.3.3, 4.7.3.4

filters, air, flammability, 4.7.3.5

filters, electrical *see* electrical filters *and* capacitors, filter

FIRE ENCLOSURES, 1.2.6.2*

air filters in, 4.7.3.5

components in, 4.7.2.1, 4.7.2.2

construction, 4.6.2, 4.6.3, 4.7.1, A.1, A.2A.5

materials, **4.7.3.2**

not required, 1.4.11, 4.7.2.2

required, **4.7.2**, 4.7.2.1

see also ENCLOSURES *and* openings in ENCLOSURES

fire protection equipment, not in Scope of standard, 1.1.3

fire hazards, 0.2.3, 0.3, 1.1.1, 1.2.9.1 (note 1), 1.3.2, **4.7**, annex P (IEC 60695)

caused by

batteries, 4.3.8

flammable liquids, 4.3.10, 4.3.12

heating elements, 4.3.7

ingress of water, annex T

FUNCTIONAL INSULATION, 1.2.9.1 (note), 5.3.4, 5.3.8

overloads, 5.3.1

see also flammability

fixed wiring *see* building installations

fixing (securing) of

equipment, 1.2.3.4, 1.2.3.5, 4.1

units, fixed together, 4.1

parts

adhesives, 4.6.5

cord guards, 3.2.8

conductors *see* wiring terminals

controls, 4.3.2

insulation, 2.6.1 (note), 3.1.5

inlet bushings, 3.2.7

minor parts, 4.3.4

two fixings not loose at the same time, 3.1.9, 4.3.4, C.2

wiring, 2.1.1.3, 2.1.1.4, 2.1.1.5, 2.2.3.1, 3.1.3

FLAMMABILITY CLASS, 1.2.12.1*, 1.3.5

5V, 1.2.12.5*, A.9

applications, 1.2.12.1, 4.7.3.2

HB, 1.2.12.8*, 4.7.3.1, A.8

applications, 1.2.12.1, 4.7.2.2, 4.7.3.3, 4.7.3.4, 4.7.3.5

HBF (foamed material), 1.2.12.9*, 4.7.3.1, A.7

applications, 1.2.12.1, 4.7.2.2, 4.7.3.3, 4.7.3.4, 4.7.3.5

HF-1 (foamed material), 1.2.12.6*, A.7

applications, 1.2.12.1, 4.6.2

HF-2 (foamed material), 1.2.12.7*, A.7

applications, 1.2.12.1, 4.7.3.4, 4.7.3.5, 4.7.3.6

V-0, 1.2.12.2*, A.6

applications, 1.2.12.1

V-1, 1.2.12.3*, A.6

applications, 1.2.12.1, 4.6.2, 4.7.2.1, 4.7.2.2, 4.7.3.1, 4.7.3.2, 4.7.3.3, 4.7.3.4,
4.7.3.5, 5.3.4

V-2, 1.2.12.4*, A.6

applications, 1.2.12.1, 4.7.3.3, 4.7.3.4, 4.7.3.5, 4.7.3.6

flammability, 0.2.3, 0.2.4, **4.7**

better class permitted, 1.3.5

exemptions from flammability requirements, 4.7.3.3, 4.7.3.4

fluids, 4.3.12

ranking (one class better than another), 1.2.12.1 (notes), 1.3.5

summary of requirements, table 4C

tests, A.1, A.2, A.6, A.7, A.8, A.9

for FIRE ENCLOSURES, A.1, A.2, A.5

floating parts and windings

see unearthed parts and windings

foil (conductive)

in definitions, 1.2.7.5, 1.2.10.3

in tests

on non-conductive surfaces, 2.10.3, 2.10.4, 2.10.8, 5.1.4,5.2.2, 6.2.2, G.6

on wire, 3.1.4

metallized plastic, 4.6.4 (note)

frequency

higher than 50/60 Hz, 0.2.6, 1.4.7, 5.1.6, 5.2.2, (note 4)

in LIMITED CURRENT CIRCUITS, 2.4.2

in TNV CIRCUITS, 2.3.1b), 6.2.2.1

of supply, 1.7.1, 1.7.4, 3.4.11, 3.2.2, annexX

during tests, 1.4.6

of electric strength test voltages, 5.2.2R.1, R.2

of WORKING VOLTAGES, 2.10.1

of ringing signals, M.2 (note), M.3.1.1

see also RATED FREQUENCY, RATED FREQUENCY RANGE

FUNCTIONAL EARTHING, 1.2.13.9*, **2.6.2**, 2.6.3, 5.1.5, 5.1.8.1

FUNCTIONAL INSULATION, 1.2.9.1*, 5.3.4

application, 2.1.1.1, 2.9.5

bridging *see* bridging of insulation,

dimensions, **2.10.3**, **2.10.4**, annex F

coated printed boards, 2.10.6, annex F (figure F.11)

distance through insulation, no requirement, 2.10.5.1

electric strength, 5.25.3.4 b)

no test, 5.2.2

failure to be simulated, 5.3.4 c)

no protection against electric shock, 1.2.9.1(note)

smaller spacings permitted, 2.10.1, 5.3.4

WORKING VOLTAGES, 2.10.2

NOTE the term FUNCTIONAL INSULATION has replaced the term OPERATIONAL INSULATION

fuseholders, 2.1.1.1 b), 2.1.1.1 c), 4.7.3.2(note)

fuses, annex Q (IEC 60127, IEC 60269-2-1,)

breaking capacity, 2.7.3(note)

in neutral conductors, 2.7.6

location, 2.7.1, 2.7.4

marking, 1.7.6

minimum number, **2.7.4**

not allowed in protective conductors, 2.6.5.2

operating during motor tests, B.2

performance, 2.5 (2C item 4)

protecting capacitors, 5.3.7

protecting telecommunication wiring, 6.3 (notes 1 and 4)

warning to SERVICE PERSONNEL, 2.7.6

G

gaps, *see* air gaps

gas discharge tubes, ~~5.3 (figure 5.2)~~, 5.2.2 (note 3), 6.2.2.3, annex S (figure S.3)

DE

see also surge arrestors

gas flames for flammability testing, annex A

gases

flammable, 1.1.2, 1.2.12.10, 4.3.10

inert, in sealed units, 4.7.3.3, 4.7.3.4

produced by equipment, 4.3.10

under pressure, 4.3.11

gel dielectrics, 2.10.5.1

glass

cloth, prepreg, 2.10.5.3(table 2M)

flammability, no test, 4.7

platen, no impact test, 4.2.5

see also ceramic and glass insulation

glow-wire tests, 4.7.3.1, annex P (IEC 60695-2-1/1)

grease, 4.3.9

see also oil

green-and-yellow *see* colours

grips *see* handles

ground, grounding, *see* earth, earthing

guards, guarding, against hazards, 0.1, 2.1.2, 2.1.3, 2.8.3, 3.4.4, 3.4.10, 4.4.1

see also cord guards

H

HAI (High Amp Ignition tests)

see high current arc ignition tests

hand, human, 0.2, 5.1.4 (note 1)

HAND-HELD EQUIPMENT, 1.2.3.2*, 3.2.8, 3.2.9

maximum RATED VOLTAGE 250 V, 1.6.3

mechanical strength, 4.2.6

power supply cords, 3.2.5

TOUCH CURRENT, 5.1.6 (table 5A)

handles

conductive, 2.1.1.6

must be reliably fixed, 4.3.2

no mechanical strength test, 4.2.1

shafts of, 2.1.1.6

temperature rise, 4.5.1

HAZARDOUS ENERGY LEVEL, 1.2.6.4, 1.2.8.8*

see also energy hazards

HAZARDOUS VOLTAGES, 1.2.8.4*

multiple sources, 1.7.9, 3.4.10

not to be accessible, 2.1.1.1

after mechanical strength tests, 4.2.1, 5.3.8.2

at appliance inlets, 3.2.4

at connectors, 3.2.2

in OPERATOR ACCESS AREAS, 2.1

in SERVICE ACCESS AREAS, 2.1.2

on thermoplastic parts, 4.5.2

protection by earthing, 2.6.1

separation from

FUNCTIONAL EARTHING circuit, 2.6.2

SELV CIRCUITS, 2.1.2, 2.2.3, 2.2.4

TNV CIRCUITS, 2.1.2, 2.3.3, 2.3.4

warning notices, 1.7.9, 2.7.6

hazards, clause 0

access using a TOOL, 1.7.16

acoustic, 0.2.6

basis of design, 0.1, 1.3.2

energy *see* energy hazards

fire *see* fire hazards

information to the USER, 1.7.2

mechanical *see* mechanical hazards

none after mechanical strength tests, 4.2.1, 5.3.8.2

SERVICE PERSONNEL aware of, 0.1, 1.2.13.5

heat

hazards, 0.2.4

red, ceramic curing temperature, 2.10.5.3 (table 2M)

shock test on winding wire, U.2.3

sinks, 4.5.1, B.2

see also fire hazards

heating, **4.5**

maximum, during transformer tests, annex X

heating elements, 4.3.7

high current arcing ignition tests, 4.7.3.2, A.3

high voltage components, 4.7.3.6

hot flaming oil tests, 4.6.2A.5

hot part symbol, 4.5.1 (table 4A item 6)

hot wire ignition tests, 4.7.3.2, A.4

humidity, 2.9.1

additional requirements if high, 1.1.2

conditioning (treatment), 2.9.2, 2.10.6.5, ~~2.10.7.8~~ 2.10.8

DE

relative (r.h.) during tests, 4.6.5, A.6.2, A.7.2, A.8.2, A.9.2, A.10 (note), U.2

HWI Hot Wire Ignition

hygroscopic material, not to be used as insulation, 2.9.1

I

ICRP 15, annex H (note), annex Q

NOTE The numbers of all IEC Standards have been increased by 60 000, e.g. IEC 950 is now IEC 60950.

IEC 60065, 4.2.8, 4.7.3.6, annex P

IEC 60073, 1.7.8.2, annex P

IEC 60083, 1.7.5, 2.1.1.1, 4.3.5, annex P

IEC 60085, 4.5.1 (table 4A, item 2), annex P

IEC 60112, 2.10.4, annex P

IEC 60127, 2.7.3, annex Q

IEC 60227, 3.2.5, annex P

IEC 60245, 3.2.5, annex P

IEC 60269-2-1, 6.3 (note 5), annex Q

IEC 60309, 1.2.5.2, 3.2.4, annex P

IEC 60320, 3.2.4, 3.2.5 (table 3B), 4.3.5, annex P

IEC 60364-3, annex P, V.1

IEC 60364-4-41, annex P, V.1

IEC 60364-7-707, 5.1.7, annex Q

IEC 60384-14, 1.5.6, 1.5.7.1, 1.5.8, annex P

IEC 60410, annex Q, R.1, R.2

IEC 60417, 1.7.1, 1.7.7.1, 1.7.8.3, 2.6.2, 4.5.1, annex P

IEC 60479-1, M.2, annex Q

IEC 60529, annex Q

IEC 60529, extract, annex T

IEC 60664-1, 2.10.3.1 (notes 1a and 2), 2.10.3.2, annex P, G.6

IEC 60664-3, 2.10.1, annex Q

IEC 60695-2-1/1, 4.7.3.1

IEC 60695-2-2, 4.2.7, A.2.7, annex P

IEC 60695-10-2, 4.5.2, annex P

IEC 60730-1, 2.5, annex P

IEC 60825-1, ~~4.13.13~~ 4.3.13, annex P

IEC 60851, annexes P and U

IEC 60851-3, annex P, U.2.2

IEC 60851-5, annex P, U.2.1, U.2.4 (note), U.3.2

DE

IEC 60851-6, annex P, U.2.3

IEC 60885-1, 3.1.4, annex P

IEC 60990, 5.1.2 (note), 5.1.3, 5.1.4 (note 2), D.1

IEC 61058-1, 2.8.7, 3.4.2, annex P

IEC 61032, 2.1.1.1 (figure 2A, notes 3 and 4), annex Q

IEC 61140, 1.2.8.6, annex Q

IEV (International Electrotechnical Vocabulary), 1.2.13.2, 1.2.13.3, 1.2.13.9, 1.2.13.12

ignition, 0.2.3, 0.2.4, 4.6.4, 4.7

tests, A.3, A.4, A.5

see also FIRE ENCLOSURES *and* glow-wire ignition tests

impact tests, 4.2.1, 4.2.5

implosion of cathode ray tubes, 0.2.5, 4.2.8

impulse tests, 2.10.3.4, **6.2.2.1**, 6.2.2.3, G.5, R.1, R.2, annex S

test generators, annex N

indicators, indicating devices

colours, 1.7.8.2, annex P (IEC 60073, ISO 3864)

exempt from mechanical strength requirements, 4.2.1

marking, 1.7.8

lamps exempt from flammability requirements, 4.7.3.3, 4.7.3.4

information technology equipment

connection to TELECOMMUNICATION NETWORKS, **clause 6**, W.2

examples in Scope of standard, **1.1.1**

informative references, annex Q

ingress of water, 1.1.2, 2.10.7, 2.10.8, annex T

ink, 4.3.12

ink tubes, 4.7.3.3, 4.7.3.4

inlet bushings, power cord, 3.2.7

installations, building *see* building installations

installation categories *see* overvoltage categories

NOTE The term *overvoltage category* has replaced the term *installation category*

installation instructions, 1.7.1, 1.7.2, 1.7.4, 2.1.1.1

disconnect devices, 3.4.3, 3.4.6, 3.4.7, 3.4.9

orientation, 1.3.6

physical, 4.1, 4.2.10, annex T

RESTRICTED ACCESS LOCATIONS, 1.7.17

wiring

earth, 2.3.2, 5.1.8.2, 6.1.1, 6.1.2.2

power, 1.7.7.2, 1.7.10, 2.7.1, G.2

telecommunication, 6.3

instructions, 0.1, **1.7.2**, 1.7.15, 2.6.5.6, 2.7.6

language, 1.7.12

see also installation instructions *and* operating instructions

insulation (electrical), 0.2.1, 1.2.9*, **2.9**

application, 2.9.1, **2.9.5**

BASIC *see* BASIC INSULATION

better grade permitted, 1.3.5

bridging *see* bridging of insulation

colour *see* colours

dimensions, **2.10**

DOUBLE *see* DOUBLE INSULATION

faults, simulated, 1.4.14

for more than one requirement, clause 6 (note 3)

FUNCTIONAL *see* FUNCTIONAL INSULATION

operational *see* FUNCTIONAL INSULATION

printed boards *see* printed boards

REINFORCED *see* REINFORCED INSULATION

separate testing, 2.9.1

solid, 2.10.5

 meaning, 2.10.5

see also distances through insulation

SUPPLEMENTARY *see* SUPPLEMENTARY INSULATION

tests, 5.2, 6.1.2, 6.2.2, annex S

with varying dimensions, 2.10.10, 5.2.2

insulation, sound-deadening, flammability testing, A.6.1

integrity of protective earthing and bonding, **2.6.5**

INTERCONNECTING CABLES, 1.2.11.6*, 1.5.5, 3.1.1

 parts of PRIMARY CIRCUITS, 1.2.8.2 (note)

 parts of SECONDARY CIRCUITS, 1.2.8.3 (note)

 parts of TNV CIRCUITS, 1.2.8.9 (note)

interconnection of equipment, 1.7.2 (note 1), 2.6.5.1, 3.4.10, **3.5**, W.2

see also connections

interleaved insulation in wound components, 2.10.5.4, annex U

interlocks *see* SAFETY INTERLOCKS

INTERMITTENT OPERATION, 1.2.2.5*, 1.7.3, 4.5.1, 5.3.7

internal wiring, 2.1.1.3, 2.1.1.4, 3.1.1, 3.1.3, 3.1.10, 4.7.3.3, 4.7.3.4, C.2

interpolation permitted

 electric strength test voltages, 5.2.2 (table 5B, part 2)

 insulation spacings, 2.10.3.1 (note 1), tables 2H, 2K, 2L and 2N; G.2

 temperature for thermal ageing, 2.10.6.4 (figure 2G)

ionizing radiation, 0.2.6, 4.3.13, annex H

ISDN (Integrated Services Digital Networks), 1.2.13.8 (note 3)

ISO 261, 3.3.3, annex P

ISO 262, 3.3.3, annex P

ISO 2859-1, annex Q, R.1, R.2

ISO 3864, 1.7.16, annex P

ISO 4046, B.7.2 (note), annex Q

ISO 7000, 1.7.1, annex P

isolation (from the supply) *see* disconnection for servicing

IT power distribution systems, 1.6.1, V.4

 heating elements, 4.3.7

 marking of equipment, 1.7.10

 primary power isolation

 single phase, 3.4.6 (note)

 three phase, 3.4.7

 protective devices, 2.7.4 (tables)

 TOUCH CURRENT, 5.1.3

 voltage rating of components, 1.5.8

ITU-T Recommendation K.11, clause 6 (note 1), annex Q

ITU-T Recommendation K.17, annex N, annex P

ITU-T Recommendation K.21, annex N, annex P

NOTE ITU-T Recommendations were formerly CCITT Recommendations

K

knobs *see* handles

L

labels *see* warning notices

lamps

 high pressure, 0.2.5, 4.2.9

 left in place during tests, 2.1.1.1

no flammability requirement, 4.7.3.3, 4.7.3.4

languages for instructions and marking, 1.7.12

lasers, 0.2.6, 4.3.13, annex P (IEC 60825-1)

leakage current, 1.2.13.12 (note), 1.2.13.13 (note), 5.1.7, 5.1.8.2

see also TOUCH CURRENT

legal requirements, 1.1.2 (note), clause 6 (note 2)

see also country notes

levers *see* handles

lightning *see* transients

LIMIT, EXPLOSION *see* EXPLOSION LIMIT

limits *see* maximum

LIMITED CURRENT CIRCUITS, 1.2.8.7*, **2.4**, 2.9.5 (note to table 2G)

connections to other equipment, 3.5.2

in OPERATOR ACCESS AREAS, 1.5.7.3, 2.1.1

limited power sources, **2.5**, 4.7.2.1, 4.7.2.2

LIMITERS, TEMPERATURE

see TEMPERATURE LIMITERS

liquids

conductive, 1.3.9, 4.3.10

containers, 4.7.3.4

under pressure, 4.3.11

flammable, 0.2.3, 0.2.4, 4.3.10, 4.3.12, 4.5.1 table 4A part 1)

parts in contact, 4.5.1

loosening *see* fixing

louvres, 4.6.1

see also openings

M

mains

as telecommunication transmission medium, 1.1.1, clause 6 (note 4)

not a TELECOMMUNICATION NETWORK, 1.2.13.8

capacitors, 1.5.6, 1.5.8, 2.1.1.7

frequency, 1.4.6, 1.4.7, 1.7.1

plugs, 1.2.3.6, 2.6.5.4, 3.2.1, 4.3.5, 4.3.6

voltage, 1.4.5, 1.7.1, 2.10.3.1, G.2

adjustment, 1.7.4, 4.3.3

d.c., 1.4.5, 1.7.1, 5.2.2 (table 5B, items 2 – 5)

line to neutral, used for determining CLEARANCES, 2.10.3.1, G.2 (table G.1)

see also A.C. MAINS SUPPLY, PRIMARY CIRCUITS

MAINS TRANSIENT VOLTAGE, 1.2.9.9*, 2.10.3.2, **G.2**, G.4

reduced levels in SECONDARY CIRCUITS, 2.10.3.3

measurement, 2.10.3.4, G.5

see also transients

marking, 0.1, 1.7

durability, 1.7.13

location, 1.7.1, 1.7.6, 1.7.8.1

t-marking, 4.5.1

see also warning notices

mass

cord anchorage test, 3.2.6

cord guard test, 3.2.8

marking not on bottom of equipment over 18 kg, 1.7.1

of equipment, criterion for requirements and tests, 1.2.3.1, 2.1.1.1, 3.2.5, 4.1, 4.2.4, 4.2.6, 4.7.3.2, A.1, A.2

steel ball impact test, 4.2.5

material group *see* tracking

materials

must be reliable, 0.3

not covered in the standard, 1.3.4

use of better materials permitted, 1.3.5

maximum

amount of flammable liquid, 4.3.12

current to telecommunication wiring, 6.3

input current, 1.6.2

ionizing radiation, 4.3.13, annex H

LIMITED CURRENT CIRCUIT levels, 2.4.2

limited power source levels, 2.5

output load, 1.7.5

overvoltages, assumed in this standard, 2.10.3.1 (note 2), clause 6 (note 1), G.2

ozone level, 1.7.2 (note 5)

power from TELECOMMUNICATION NETWORK 15 VA, 1.4.11

RATED VOLTAGE

250 v for HAND-HELD EQUIPMENT, 1.6.3

600 v in Scope of standard, 1.1.1

ringing signal level, M.2, M.3

ripple *see* ripple

SELV CIRCUIT voltages

normal, 2.2.2

fault conditions, 2.2.3

temperature (rise), 1.4.12, 1.4.13, 4.5.1

in OPERATOR ACCESS AREAS, **4.5.1**

of

conductors, 3.1.1
insulation during tests, 5.3.8.1
materials and components, 0.2.4, **4.5.1**
motors, **B.3**, B.4, B.5, B.7.1, B.8, B.9
transformers, C.1, annex X
windings, 1.4.13, annex E

TNV CIRCUIT voltages

TNV-1 CIRCUITS, 2.3.1 a)

TNV-2 and TNV-3 CIRCUITS, 2.3.1 b)

TOUCH CURRENT, 5.1.1, 5.1.6, 5.1.8.1, 5.1.8.2

transient voltages *see* transients

measuring instruments, electrical, 1.4.7, 1.4.9, 5.1, annex D

ammeters, 5.1.7

MECHANICAL ENCLOSURES, 1.2.6.3*, **4.2**, **4.4**

see also ENCLOSURES, openings in ENCLOSURES

mechanical hazards, 0.2.5, 2.8.2, 4.1

mechanical shock

affecting CLEARANCES, 2.10.3.1 (note 6), G.6 (note 2)

affecting interlocks, 2.8.3

mechanical strength, **4.2**

cathode ray tubes, 0.2.5, 4.2.8

handles (no test), 4.2.1

high pressure lamps, 4.2.9

in interlocks, 2.8.5, 2.8.8

no test in MECHANICAL ENCLOSURES, 4.2.1

mechanical stress, on insulation, 2.10.5.4, 3.2.7, 5.2.2

mechanically operated switches in interlock systems, 2.8.7

mechanically operated parts in interlock systems, 2.8.4, 2.8.5

metal

cores in printed boards, 2.10.5.3, 2.10.6.6

foil *see* foil, conductive

screens *see* screens, conductive

metals, no flammability test, 4.7

micro-environmental category *see* pollution (degree)

misuse, foreseeable, 0.1, 5.3.1

mobility of equipment (definitions), 1.2.3*

moisture *see* humidity and water ingress

motor-generator sets, not in Scope of standard, 1.1.3

motors

requirements, 5.3.2

tests, annex B

at RATED VOLTAGE, B.2

d.c. motors, B.1, B.6, B.7, B.10

locked rotor, B.5

running overload, B.4

series motors, B.10

stepper motors, B.1

three-phase motors, B.9

MOVABLE EQUIPMENT, 1.2.3.1*, 1.2.3.2, 1.2.3.3, 1.2.3.4

FIRE ENCLOSURES, 4.7.3.2, A.1, A.2

power supply cord flexing test, 3.2.5

movable parts of equipment, 1.4.4, 2.1.1.1, 2.10.3.1, 2.10.4, G.6

see also removable parts

moving parts of

equipment, 2.8.2, 3.1.2, 4.2.1, 4.4

interlock systems, 2.8.4, 2.8.5

multiple power sources, 1.1.3, 1.7.9, 2.6.4.1, 3.2.2, 3.4.11, 5.1.2

N

national requirements *see* country notes *and* legal requirements

neoprene, 4.7.2.2, 4.7.3.3, 4.7.3.4

see also rubber, synthetic

networks *see* TELECOMMUNICATION NETWORKS

neutral conductors, 1.6.4

disconnection by disconnect devices, 3.4.6, 3.4.7

disconnection by protective devices, 2.7.4, 4.3.7

fuses in neutral, warning required, 2.7.6

marking of terminals, 1.7.7.2

earthed and reliably identified, 3.4.6, 2.7.4

noise hazard (acoustic), 0.2.6

nominal A.C. MAINS SUPPLY VOLTAGES, 2.10.3.2 (tables 2H, 2J and 2K), G.2 (table G.1)

NON-DETACHABLE POWER SUPPLY CORDS

see power (supply) cords

NORMAL LOAD conditions, 1.2.2.1*, 1.6.2, 4.5.1, annex L

normative references, annex P

O

oil, 4.3.9, 4.3.12

hot flaming oil test, A.5

see also liquids

openings in ENCLOSURES, **4.6**

access through, 2.1.1.1, 4.4.2

components which fill, 4.7.2.2, 4.7.3.2

for power cords, 3.2.7, 3.2.8

in tops and sides of ENCLOSURES, 4.6.1

in bottoms of ENCLOSURES, 4.6.2

in TRANSPORTABLE EQUIPMENT, 4.6.4

measuring through, 2.10.3.1, 2.10.4, G.6

ventilation, in FIRE ENCLOSURES, 4.7.3.3, 4.7.3.4, A.1.5, A.2.1

operating conditions (definitions), 1.2.2*

operating instructions, 1.2.2.1, 1.2.7.1, 1.3.6, 1.4.4, 1.7.2, 1.7.15, 2.1.1.2, 3.4.10, 3.4.11, 4.4.2, 4.6.3 c), annex L

OPERATION, CONTINUOUS

see CONTINUOUS OPERATION

OPERATION, INTERMITTENT

see INTERMITTENT OPERATION

OPERATION, SHORT-TIME

see SHORT-TIME OPERATION

operational insulation *see* FUNCTIONAL INSULATION

NOTE The term FUNCTIONAL INSULATION has replaced the term operational insulation

OPERATORS (or USERS which has the same meaning), 0.1, 1.2.3.3, 1.2.13.6, 1.2.13.7*

information supplied to, 1.2.7.3, 1.7.2, 2.1.1.2

of telecommunications equipment, 6.1, 6.2

servicing by OPERATOR

handling insulation, 2.10.5.2

high pressure lamps, 4.2.9

stability, 4.1

see also USERS

OPERATOR ACCESS AREAS, 0.1, 1.2.7.1*, **2.1**

access probes, 2.1.1.1, 2.1.1.2

compared with RESTRICTED ACCESS LOCATIONS, 1.2.7.3 (note), 2.1.3

doors in FIRE ENCLOSURES, 4.6.3

markings to be visible, 1.7.1

TOOL required for access, 1.2.7.1, 1.7.16

ordinary NON-DETACHABLE POWER SUPPLY CORDS, 1.2.5.5

see also power (supply) cords

orientation (attitude), 1.3.6

overcurrent and earth fault protection, 0.2.3, 2.7, annex P (ITU-T Rec. K.21)

overcurrent protection devices

air gaps *see* air gaps

in limited power sources, 2.5

not damaged during tests, 4.2.1

overcurrent protection for telecommunication wiring, 6.3

overcurrent protection for transformers, 5.3.3, C.1, annex X

overriding interlocks, 2.8.6

overheating of telecommunication wiring, 6.3

overload

mechanical, 5.3.1

electrical, 3.1.1, 5.3.1, 6.3

see also overcurrent

motors, 5.3.2, B.2 (table B.2), B.4, B.5, B.6, B.7

tests, 5.3.6

transformers, **5.3.3, C.1, annex X**

overvoltage categories, 2.10.3.1 (notes 2 and 3), 2.10.3.2, 2.10.3.3, G.2

NOTE The term overvoltage category has replaced the term installation category

overvoltages, 1.2.8.10, 1.2.8.11, 1.2.8.12, 1.2.13.8, 1.4.8, 2.2.2 (note), annex P (ITU-T Rec. K.21), annex Q (ITU-T Rec. K.11)

maximum levels assumed in this standard, 2.10.3.1 (note 2), clause 6 (note 1), G.2

see also overvoltage categories *and* transients

ozone, 1.7.2

P

Part 68, FCC Rules, M.3 (note), annex P

passive devices, not in Scope of standard, 1.1.3

PEAK WORKING VOLTAGE, 1.2.9.7*, 2.10.3.2, 2.10.3.3, 2.10.5.1, G.1, G.4, G.6

PERMANENTLY CONNECTED EQUIPMENT, 1.2.5.3*

discharge of capacitors, 2.1.1.7

disconnect devices, 3.4.3

earthing, 2.3.2 (note 5), 2.6.4.1, 2.6.4.2, 6.1.2.1, 6.1.2.2

marking, 1.7.2, 1.7.7.2

overcurrent protection, 2.7.1, 2.7.3, 2.7.6

terminals, **3.2.3**, 3.3.3, 3.3.7

TOUCH CURRENT, 5.1.1, 5.1.7

permission to connect to TELECOMMUNICATION NETWORKS

see legal requirements

personnel, network service, 5.1.8.2, 6.1

PERSONNEL, SERVICE *see* SERVICE PERSONNEL

plating, protective earthing components, 2.6.5.6

PLUGGABLE EQUIPMENT, 1.7.2, 4.3.7

discharging filter capacitors, 2.1.1.7

earthing, 2.3.2

isolation, 3.4.2, 3.4.6

overcurrent protection

TYPE A, 1.2.5.1*, 2.1.1.7, 2.3.2, 2.7.3, 2.10.3.1, 5.1.6 (table 5A), 5.1.8.2, 6.1.2.1 (notes 1 and 2), G.6

TYPE B, 1.2.5.2*, 2.3.2, 2.3.3 (note 1), 2.7.1, 2.7.3, 5.1.1, 5.1.7, 5.1.8.2, 6.1.2.2

plugs *see* connectors *and* mains

pollution (degree), 0.1, 2.9.1, 2.10.1, 2.10.3.2 (tables), 2.10.3.3 (table 2K), 2.10.4 (table 2L), annex F (table F.1)

pollution degree 1 applies, 2.10.7

polyimide insulating material, 4.7.2.2, 4.7.3.3, 4.7.3.4

powder, 4.3.10

containers, 4.7.3.4

power

apparent, 2.5 (tables)

connections to equipment, **3.2**

distribution systems *see* power distribution systems

factor of test current, A.3.3

from a TELECOMMUNICATION NETWORK 15VA, 1.4.11

no power required, excluded from Scope of standard, 1.1.3

outlets on equipment *see* socket-outlets on equipment

supplied to telecommunication wiring, 6.3

rating, marking, **1.7.1**, 1.7.4

sources for equipment

any, included in Scope, 1.1.1

multiple *see* multiple power sources

power distribution systems, a.c., 1.2.8.1, 1.6.1, annex V

single phase, three wire, V.2 (figure V.4)

power (supply) cords, 3.2.1, **3.2.5**

DETACHABLE POWER SUPPLY CORDS, 1.2.5.4*, 2.6.4.1

marking of wiring terminals, 1.7.7

NON-DETACHABLE POWER SUPPLY CORDS, 1.2.5.5*, 3.2.1, 3.2.3, 3.2.5, 3.2.7, 4.5.1 (table 4A part 1)

ordinary, 1.7.7.2, 2.10.4, 3.2.6, 3.2.9, 3.3.1, 3.3.7

special, 2.6.4.2, 3.3.2, 3.3.8

inside the equipment, 3.1.4

PROTECTIVE EARTHING CONDUCTORS, 2.6.3.1, 3.2.5, 3.2.6

colour of insulation, 2.6.3.4

screened, 3.2.5, 3.2.6

voltage drop not measured, 1.4.9, 2.6.3.3

power supply units in equipment, earth terminal marking, 1.7.7.1

pre-preg, 2.10.5.3 (table 2M)

PRIMARY CIRCUITS, 1.2.8.2*, 1.2.8.3

capacitors in, 1.5.6, 2.1.1.7

CLEARANCES in, 2.10.3.2, annex G

faults in components in, 5.3.6

filters in, 0.2.1, 5.1

interlock switches, contact gaps, 2.8.7.1, 2.8.7.4

internal wiring, 3.1.1

marking of switches, 1.7.8

marking of terminals, 1.7.7

protection, 2.7

WORKING VOLTAGES in, 2.10.2

see also mains

primary power *see* A.C. MAINS SUPPLY and PRIMARY CIRCUITS

principles of safety, clause 0

printed boards

coated, 2.10.6

CLEARANCES and CREEPAGE DISTANCES, 2.10.6.1, annex F (figure F.11), R.1

distances through insulation, 2.10.5.3

metal core, 2.10.5.3, 2.10.6.6

multi-layer, 2.10.5.3, 2.10.8

quality control, R.1

printed wiring, colours of flexible, 2.6.3.4

see also printed boards

proof tracking index (PTI) *see* tracking

protection

against electric shock and energy hazards, **2.1, clause 6**

against overcurrent and earth faults, **2.7**

backup protection, 2.7.3

provided by building installations, 2.7.1, 2.7.3

in SERVICE ACCESS AREAS, **2.1.2**

in RESTRICTED ACCESS LOCATIONS, 2.1.3

of network SERVICE PERSONNEL, **6.1**

of (telecommunication) equipment USERS, **6.1, 6.2**

of telecommunication wiring, 6.3

PROTECTIVE CONDUCTOR CURRENT, 1.2.13.13*, 5.1.1, 5.1.7, annex P (IEC 60990)

protective coverings in place during tests, 5.3.1

protective devices, **2.7**

PROTECTIVE BONDING CONDUCTORS, 1.2.13.11*, 2.6.3

colour of insulation, 2.6.3.4

components not allowed in, 2.6.5.2

integrity to be assured, **2.6.5**

resistance, 2.6.3.3

separation from PROTECTIVE EARTHING CONDUCTORS, 2.6.4.2

size, 2.6.3.2

terminals, 2.6.4.1

protective earth and TELECOMMUNICATION NETWORKS, 1.7.7.1, 2.6 (note), 2.6.5.8, 5.1.8, 6.1.2, annex W

protective earthing and bonding, **2.6**

corrosion resistance of conductive parts, 2.6.5.6

screws, 2.6.5.7, 3.1.6

PROTECTIVE EARTHING CONDUCTORS, 1.2.13.10*, 2.6.3

colour of insulation, 2.6.3.4

components not allowed in, 2.6.5.2

in power supply cord, 3.2.5, 3.2.6

integrity to be assured, 2.3.2, **2.6.5**, 5.1.7, 5.1.8.2 a), 6.1.1, 6.1.2.2

resistance, 2.6.3.3

separation from PROTECTIVE BONDING CONDUCTORS, 2.6.4.2

size, 2.6.3.1

terminals, 1.7.7.1, 2.3.2, 2.6.4.1, 3.3

voltage drop not measured, 1.4.9, 2.6.3.3

see also PLUGGABLE EQUIPMENT TYPE B

PTFE (polytetrafluoro ethylene), 4.7.2.2, 4.7.3.3, 4.7.3.4

PTC (positive temperature coefficient) devices, 2.5

PTI (proof tracking index) *see* tracking

PVC (polyvinyl chloride), 3.2.5, 4.5.1 (table 4A part 1), 4.7.2.2, 4.7.3.3, 4.7.3.4, annex P (IEC 60227)

Q

quality control, 2.10.3.2 (table 2H item 2), 2.10.3.3 (table 2K, item 2), 2.10.6.1, 2.10.9, G.6 (table G.2, item 2)

quality control programmes, annex R

R

radiation

hazards, 0.2.6

ionizing, 4.3.13, annex H

range

of conductor sizes, 3.3.4, 3.3.5

current, 1.7.1

frequency *see* RATED FREQUENCY RANGE

voltage *see* RATED VOLTAGE RANGE

RATED CURRENT, 1.2.1.3*

input current not to exceed, 1.6.2

marking, 1.7.1

power supply cord ampacity, 2.6.3.1, 3.2.5

purpose of marking, 1.7.1

range, 1.7.1

terminal sizes, 3.3.5

rated current of overcurrent devices, 1.7.6, 2.5

RATED FREQUENCY, 1.2.1.4*, 1.4.6, 1.7.1, 1.7.4

RATED FREQUENCY RANGE, 1.2.1.5*, 1.4.6, 1.7.1, 1.7.4

RATED OPERATING TIME, 1.2.2.2*, 1.7.3, 4.5.1, 5.3.7

RATED VOLTAGE of equipment, 1.2.1.1*

IT power distribution systems, 1.5.8

marking and instructions, 1.7.1, 1.7.4

maximum value

250 V for HAND-HELD EQUIPMENT, 1.6.3

600 V in Scope of standard, 1.1.1

tolerance, 1.4.5

used for tests, 1.4.5, 1.6.2, 5.1.3, 6.1.2.1, B.2, annex K

when determining WORKING VOLTAGE, 2.10.2

when measuring input current, 1.6.2

RATED VOLTAGE RANGE of equipment, 1.2.1.2*

marking, 1.7.1

used for tests, 1.4.5, 5.1.3, 6.1.2.1, B.2, annex K

when determining WORKING VOLTAGE, 2.10.2

when measuring input current, 1.6.2

rated voltage of components, 1.6.4

capacitors, 1.5.7.1, 1.5.7.2, 1.5.8

fuses, 1.7.6

motors, used for tests, B.6, B.10

surge suppressors, 6.1.2.1

redundant power supplies *see* backup sources of power

reed switches, reliability tests, 2.8.7.3

REINFORCED INSULATION, 0.2.1, 1.2.9.5*

application, 2.1.1.6, 2.9.5

in

FUNCTIONAL EARTHING circuits, 2.6.2

internal wiring, 2.1.1.6

manual controls, 2.1.1.6

printed boards, 2.10.6, annex F (figure F.11)

SELV CIRCUITS, 2.2.3, 2.2.3.1, 2.2.4

TNV CIRCUITS, 2.3.3, 2.3.4

wound components, 2.10.5.4

bridging *see* bridging of insulation

dimensions, **2.10.3.1**, **2.10.4**, **2.10.5**, annex F, R.1, R.2, G.6

electric strength, **5.2**

integrity

after tests, 4.2.1, 5.3.4, 5.3.6, 5.3.8.2

in service, 3.1.6, 4.3.4

protective devices not needed, 2.7.4

WORKING VOLTAGES, 2.10.2

relative humidity *see* humidity

relays, 1.5.1 (note 2)

in FIRE ENCLOSURES, 4.7.2.1

in interlock systems, 2.8.7

motor starting, B.5

reliability *see* endurance testing

removable parts, 1.7.14, 2.1.2, 3.2.7, 4.6.3

REQUIRED WITHSTAND VOLTAGE, 1.2.9.8*, G.1, G.4, G.6

requirements of the standard,

applicable only if safety is involved, 1.3.1

resistance, protective conductors, 2.6.3.3

resistance to fire *see* fire hazard

resistors

bridging *see* bridging of insulation

faults in, 1.4.14, ~~5.4.6~~ 5.3.6

DE

RESTRICTED ACCESS LOCATIONS, 0.1, 1.2.7.3*, 2.1.1.1, **2.1.3**

compared with OPERATOR ACCESS AREAS, 1.2.7.3 (note), 2.1.3

installation instructions, 1.7.17

mechanical hazards in, 4.4.3

temperature rise, exception for heat sinks, 4.5.1

r.f.i. *see* electrical filters

ringing signals *see* telephone ringing signals

ripple in DC VOLTAGE

definition, ~~1.2.14.3~~ 1.2.13.4

DE

in WORKING VOLTAGES, 2.10.3.2, 2.10.3.3, 2.10.4

in limited power sources, 2.5 (table 2B, item 1, table 2C, item 1)

r.m.s. values implied unless otherwise specified, 1.2

ROUTINE TESTS, 1.2.13.3*

coated printed boards, 2.10.6.1, R.1 (table R.1)

distances through insulation, 2.10.5.1, 2.10.5.3

electric strength, for ROUTINE TEST, 5.2.2 (note 1)

reduced CLEARANCES, 2.10.3.2 (table 2H item 2), 2.10.3.3, (table 2K, item 2), 2.10.6.1, 2.10.9, G.6 (table G.2, item 2), R.2 (table R.2)

winding wire, U.3.1

wound components, 2.10.5.4

routing of wiring, 2.1.1.3, 2.1.1.4, 2.2.3.1, 3.1.3

rubber

cable insulation, annex P (IEC 60245)

natural, not to be used as insulation, 2.9.1

rollers, 4.7.3.3, 4.7.3.4

synthetic, as insulation, 3.1.9, 3.2.5, 4.5.1 (table 4A),

running overload tests

a.c. motors, B.4

d.c. motors, B.6

S

SAFETY INTERLOCKS, 1.2.7.6*, 2.8

fail-safe operation, 2.8.4

mechanical actuators, 2.8.5, 2.8.8

not damaged during mechanical strength tests, 4.2.1

overriding interlocks

by SERVICE PERSONNEL, 2.8.6

TOOL required, 2.8.6

mechanical shock affecting, 2.8.3

tests

switches and relays

endurance, 2.8.7.3

overload, 2.8.7.2

moving parts, 2.8.5

samples for test

components, 1.5.2

equipment, 1.2.13.1, 1.2.13.2, 1.2.13.3, 1.4.3

to be as supplied to USERS, 1.4.3

SAMPLING TESTS, 1.2.13.2*, R.1, R.2, U.3.2

Scope of standard, 1.1

screens

bottom of FIRE ENCLOSURE, 4.6.2, 4.7.3.5

conductive, 2.9.5 (note to table 2G)

earthed, 0.2.1, 1.4.14, 2.6.1 f), 2.10.3.3, C.2, G.4 a)

for SELV CIRCUITS, 2.2.3.2, 2.2.4

for TNV CIRCUITS, 2.3.3, 2.3.4

for FUNCTIONAL EARTHING circuit, 2.6.2

in power supply cords, 3.2.5

mechanical, 4.2.1, 4.4.2, 4.6.4

secured with adhesive, 4.6.5

screws, screw connections, annex P (ISO 261, ISO 262)

for electrical contact, 3.1.6, 3.1.8

for protective earthing continuity, 2.6.4.1, 2.6.4.2, 2.6.5.7, 3.1.6, 3.1.8, 3.3.1, 3.3.3, 3.3.5, 3.3.6, 3.3.8

for securing parts, 4.3.4

in or made of insulating material, 3.1.7, 3.2.6

no markings on, 1.7.7.1, 1.7.7.2

self-tapping and spaced thread, 2.6.5.7, 3.1.8

terminals, 1.2.5.3, 2.6.4.1, 2.6.4.2, 3.1.9, 3.3.1, 3.3.3, 3.3.5, 3.3.6, 3.3.8

sealed, sealing

components, 2.10.7, 4.7.3.3, 4.7.3.4

compounds, 2.1.1.1, 4.3.2, 4.5.1

layers of insulation tape on winding wire, 2.10.5.4, U.1

liquid reservoirs, 4.3.12

kits (against moisture), annex T

SECONDARY CIRCUITS, 1.2.8.3*, 1.2.8.5, 1.2.8.6, 1.2.8.9, 2.9.5

CLEARANCES in, 2.10.3.3, annex G

electromagnetic components in, 5.3.5

FIRE ENCLOSURES, 4.7.2.1, 4.7.2.2

floating, 2.10.3.3, G.4 a)

hazardous voltage, 1.5.6, 2.1.3

motors in, 5.3.2, B.1, B.6, B.7

switches in, 1.7.8.3

transients in, 2.10.3.3, G.4 a)

TNV CIRCUITS, 1.2.8.9

WORKING VOLTAGE

over 10 kV, 5.2.2 (table 5B part 1, item 1)

between PRIMARY CIRCUITS and SECONDARY CIRCUITS, 2.10.2

secondary winding overload tests, C.1, annex X

securing *see* fixing

SELV CIRCUITS, 1.2.8.6*, **2.2**

accessibility, **2.1.1**

barriers in, 2.2.3.1

boundaries of, 2.2.2 (note), 2.2.4

compared with TNV CIRCUITS, 1.2.8.9 (table 1A)

connected to TELECOMMUNICATION NETWORKS, 1.4.11, 2.2.2 (note), ~~2.10.4.3~~ 2.10.3.4, **6.1.1**, DE
G.3

connections to other circuits, 2.2.4

connections to other equipment, 3.5.1, 3.5.2, W.2

connectors, 4.3.5

different from the term "SELV system" in IEC 61140, 1.2.8.6 (note 2)

earthing, 2.2.3.3, 2.6.3.3

faults, 1.2.8.6, 1.4.14, 2.2.1, 2.2.3, 2.3.1

FIRE ENCLOSURES not required, 1.4.11, 4.7.2.2

insulation, 2.9.5

maximum voltages

normal conditions, 1.4.8, 2.2.2

fault conditions, 2.2.3, 2.3.1

methods of protecting, **2.2.3**

earthing, 2.6.3.3

separation

from accessible parts, no requirement, 2.1.1

from other circuits, 2.2.3, 2.9.5 (table 2G), 3.1.9, 6.2.1

TELECOMMUNICATION NETWORKS, excluded from, 1.2.13.8

WORKING VOLTAGES, 2.10.2

semiconductor devices

faults, 1.4.14, 5.3.6

filled with insulating compound, 2.10.5.1

see also components *and* surge arrestors

separation distances under coatings

around terminals, 2.10.9, annex F (figure F.10)

coated printed boards, 2.10.6.1, 2.10.6.2, R.1

SERVICE ACCESS AREAS, 1.2.7.2*

see also RESTRICTED ACCESS LOCATIONS *and* service personnel

service manuals *see* servicing instructions

SERVICE PERSONNEL, 0.1, 1.2.13.5*

connectors accessible to, 4.3.5

of TELECOMMUNICATION NETWORKS, 5.1.8.2, 6.1

overriding interlocks, 2.8.6

protection, 1.1.1

from unearthed parts, 2.6.1

from unexpected hazards, 2.1.2, 2.1.3, 3.4.4

mechanical hazards, 4.1, 4.4.3, 4.4.4

stability, 4.1

warning notices, 1.7.9, 2.6.1, 2.7.6, 3.4.10

see also RESTRICTED ACCESS LOCATIONS

servicing controls, annex H

servicing instructions, 1.7.2

available only to SERVICE PERSONNEL, 1.7.2 (note 3)

batteries, 1.7.15

disconnection, 1.7.2, 1.7.9, 2.6.5.5

fuse ratings, 1.7.6

languages, 1.7.12

supply voltage adjustment, 1.7.4, 4.3.3

see also service personnel

sheaths (of power supply cords), 3.1.4, 3.2.5, 3.2.7

shields, *see* screens, electromagnetic

shock, electric *see* electric shock

shock, mechanical *see* mechanical shock

short circuits, 2.7

of

batteries, 4.3.8

during servicing, 2.1.2, 2.1.3

insulation, for test, 2.3.2, 2.10.2, 5.3.4 c)

limited power sources, 2.5

motor capacitors, B.8

temperature limiters in unattended equipment, 5.3.7

transformers, C.1, annex X

protection against, 2.7, 3.1.1, 5.3.1

see also energy hazards

SHORT-TIME OPERATION, 1.2.2.4*, 1.7.3, 4.5.1, 5.3.7

simulated

body impedance, 5.1, W.1.1

conditions for test, 1.4.10, 2.3.2, 2.3.4, 4.5.1, 5.1.5, 5.3.1, B.2, C.1, L.6, annex T

external voltages, 2.3.5

interference, annex N

NOTE Fault conditions are simulated in numerous places in the standard

sleeving as additional insulation, 2.10.5.4, 3.1.4, 3.1.10

around insulating beads, 3.1.5

small parts, flammability, 4.7.3.1 (note 3), 4.7.3.3, 4.7.3.4

socket-outlets, annex P (IEC 60083, IEC 60309)

in building installations

for DIRECT PLUG-IN EQUIPMENT, 1.2.3.6, 4.3.6

for PLUGGABLE EQUIPMENT, 1.2.5.1, 1.2.5.2, 1.7.2

protective earthing connection required, 6.1.2.2

reversible, 3.4.6, 4.3.7

on equipment, 1.7.5

accessibility, 2.1.1.1

loads to be taken into account, 1.4.10, 5.3.6

sockets *see* connectors *and* socket-outlets

softening of insulating materials, 4.5.1 (table 4A, item 7)

solenoids *see* wound components

solid insulation, 2.6.1 (note), 2.10.1, **2.10.5**

electric strength, 5.2

formed by insulating compound, 2.10.8

meaning of term, 2.10.5 (note 1)

must be adequate, 2.9.1

see also distances through insulation

solvent-based enamel

see enamel

special NON-DETACHABLE POWER SUPPLY CORDS, 1.2.5.5

see also power (supply) cords

stability

of operation, thermal controls, K.6

physical, 4.1

stand-by condition, marking, 1.7.8.3

STATIONARY EQUIPMENT, 1.2.3.4*, 4.5.1 (table 4A part 1)

ENCLOSURES, 4.7.3.2, A.1, A.2, A.5

marking, 1.7.1, 4.6.2

temperature of earthing terminals, 4.5.1 (table 4A part 1)

TOUCH CURRENT, 5.1.7

steady force tests when measuring CLEARANCE, 2.10.3.1, G.6

steady force tests, 10 N, 3.1.5, 3.1.9, 4.2.1, 4.2.2

steady force tests, 30 N, 4.2.1, 4.2.3

steady force tests, 250 N, 4.2.1, 4.2.4

steel ball impact tests, 4.2.1, 4.2.5

strain relief

on fluid containers, 4.3.11

on power cords, 3.2.6

stranded conductors, 1.2.5.5, 3.1.9, **3.3.8**

stress, mechanical, on insulation, 2.10.5.4

stress relief

conditioning of plastic materials, A.10

test on plastic materials, 4.2.1, 4.2.7

subassembly testing, 1.4.3, 4.5.1, 5.2.1, 5.3.1, B.2

switch mode power supply units, C.1

SUPPLEMENTARY INSULATION, 0.2.1, 1.2.9.3*, 1.2.9.4, 1.2.9.5 (note)

application, 2.1.1.6, 2.9.5

as sleeving, 3.1.4, 3.1.10

in

cord anchorages, 3.2.6

internal wiring, 2.1.1.3

manual controls, 2.1.1.6

power supply cords, 3.1.4

printed boards, 2.10.6, annex F (figure F.11)

SELV CIRCUITS, 2.2.3

wound components, 2.10.5.4

bridging *see* bridging of insulation

consequences of failure, 2.2.3, 2.4.1

dimensions, **2.10.3.1**, **2.10.4**, **2.10.5**, annex F, R.1, R.2, G.6

electric strength, **5.2**

integrity

after a test, 4.2.1, 5.3.4, 5.3.6, 5.3.8.2

in service, 3.1.6, 3.3.8, 4.3.4

interchanged with BASIC INSULATION, 2.9.5

one element of DOUBLE INSULATION, 2.10.2, 5.3.8.2

WORKING VOLTAGES, 2.10.2

surge arrestors (suppressors), 2.6.1 f), 2.10.3.4, 5.2.2 (note 3), 6.1, 6.1.2.1, 6.2.1 (figure 6A), 6.2.2.2, 6.2.2.3, G.5, annex S

switch mode power supplies, G.1 (note)

testing, C.1, annex X

see also peak voltage, repetitive

switches

arcing, 4.7.3.2

as disconnect devices *see* disconnection for servicing

for appliances *see* IEC 61058-1

forbidden in PROTECTIVE EARTHING CONDUCTORS and PROTECTIVE BONDING CONDUCTORS, 2.6.5.2

functional, 3.4.2

in FIRE ENCLOSURES, 4.7.2.1, 4.7.3.2

in PRIMARY CIRCUITS, 5.3.6

isolating, 3.4.2, 3.4.5, 3.4.8

marking, 1.7.8.1, 1.7.8.3, 4.3.2

microgap, CLEARANCES not applicable, 2.10.3.1, G.6

reed, reliability tests, 2.8.7.3

safety interlock, 2.8.3, 2.8.7

terminals of, 3.3.3

thermal control, annex K

symbols, marking, 1.7.11, 1.7.16

see also IEC 60417

T

TELECOMMUNICATION NETWORKS, 1.2.13.8*

connected to SELV CIRCUITS OR TNV CIRCUITS, 1.2.13.8 (note 1), 1.4.8, 2.2.2 (note), **6.1.1**

connections to, 1.2.11.6, 1.4.11, 2.6.2, clause 6, W.2

earthing requirements, 2.3.2, 2.3.3, 6.1.1

equipment powered from, included in Scope of standard, 1.1.1

not a reliable earth, 2.6.5.8

operating voltages generated in, 0.2.1, 2.3.5, 2.10.4

see also telephone ringing signals

power limit 15 VA, 1.4.11

separation from

earth, **6.1.2**

hazardous voltages, **6.1.1**

parts of equipment, **6.2**

surge protection, 6.2.1 (figure 6A)

TOUCH CURRENT, to and from, 2.6.1 g), 2.6.3, 5.1.8

TELECOMMUNICATION NETWORK TRANSIENT VOLTAGES, 1.2.8.9 (table 1A), 1.2.8.10, 1.2.8.11, 1.2.8.12, 1.2.9.10*, 1.2.13.8 (note 2), 2.10.3.3, G.1, **G.3**, G.4 b)

measuring reduced levels, 2.10.3.4 b), G.5 b)

telecommunication wiring, protection, 6.3

telegraph signals, not considered, 2.3.1 (note 4)

telephone ringing signals

considered as operating voltages, 0.2.1, 1.4.8

disregarded for CREEPAGE DISTANCES, 2.10.4

frequency, M.2 (note), M.3.1.1

in RESTRICTED ACCESS LOCATIONS, 2.1.3

maximum levels, 2.3.1 b), M.2, M.3

television distribution systems, 1.2.13.8

temperature, temperature rise

ambient during tests, 1.4.12, 2.9.2, annex E, U.2

applied to parts under test, 2.9.1, 2.10.6.3, 2.10.6.4, 2.10.7, 2.10.8, 4.5.2, 4.6.5, 5.2.1, A.10

conditioning, 4.6.5, A.1.2, A.2.2, A.6.2, A.7.2, A.8.2, A.9.2, A.10

extreme, 1.1.2

hazards, 0.2.3, 0.2.4, 2.9.1

heat sinks, 4.5.1

maximum *see* maximum temperature (rise)

measurement, 1.4.12, 1.4.13, 4.5.1

windings, annex E

NOTE Temperature measurements are required in numerous places in the standard

TEMPERATURE LIMITERS, 1.2.11.2*, 1.5.3, 1.7.11, 5.3.7, annex K

operate during tests, 4.5.1

terminals *see* wiring terminals

test, testing

applicable only if safety is involved, 1.4.1

choice of methods of test, 1.3.7

endurance *see* endurance testing

equipment not operational after a test, 1.4.1

fingers, 2.1.1.1 (figure 2A), annex F (figure F.12)

NOTE Test fingers are specified for checking access in numerous places in the standard

general conditions, 1.4

pins, 2.1.1.1 and figure 2B

probes, 2.1.1.1 and figure 2C, 6.2.1 b)

reliability *see* endurance testing

ROUTINE *see* ROUTINE TESTS

samples *see* samples for test

SAMPLING *see* SAMPLING TESTS

TYPE *see* TYPE TESTS

see also tests, specific

tests, specific

abnormal conditions, 5.3

abrasion resistance, 2.10.6.6, 2.10.9

adhesive ageing, 4.6.5

ball pressure, 4.5.2

current supplied to telecommunication wiring, 6.3

drop, 4.2.1, 4.2.6

flammability, A.1, A.2, A.6, A.7, A.8, A.9

electric strength *see* electric strength tests

glow wire, 4.7.3.1, annex P (IEC 60695-2-1/1)

high current arcing ignition (high amp ignition), 4.7.3.2, A.3

hot flaming oil, 4.6.2, A.5

hot wire ignition, 4.7.3.2, A.4

ignition, 0.2.3, 0.2.4, 4.6.4, 4.7, A.3, A.4, A.5

impact, 4.2.1, 4.2.5

- implosion tests (cathode ray tubes), 4.2.8
- impulse *see* impulse tests
- steady force, 10 N, 3.1.5, 3.1.9, 4.2.1, 4.2.2
- steady force, 30 N, 4.2.1, 4.2.3
- steady force, 250 N, 4.2.1, 4.2.4
- steel ball impact, 4.2.1, 4.2.5
- stress relief on plastic materials, 4.2.1, 4.2.7, A.10
- thermal ageing, 2.10.5.3 (table 2M, item 1), 2.10.6.4, R.1
- thermal cycling, 2.10.5.3 (table 2M), 2.10.6.3, 2.10.7, 2.10.8, R.1
- TOUCH CURRENT, 5.1
- transient voltage, 2.10.3.4, G.5
- TFE (tetrafluoro ethylene), 4.7.2.2, 4.7.3.3, 4.7.3.4
- thermal ageing *see* tests, specific, thermal ageing
- thermal cycling *see* tests, specific, thermal cycling
- THERMAL CUTOUPS, 1.2.11.3*, 1.5.3, 4.3.7, 5.3.1, 5.3.2, 5.3.3, 5.3.7, B.2, C.1, annex K, annex X
 - AUTOMATIC RESET, 1.2.11.4*, 4.4.1
 - MANUAL RESET, 1.2.11.5*
 - contact gaps, CLEARANCES not applicable, 2.10.3.1, G.6
 - integrity after tests, 4.2.1
 - not to operate during heating tests, 4.5.1
- thermal requirements, **4.5**
- thermoplastic parts, 4.2.7, 4.5.1, 4.5.2
- THERMOSTATS, 1.2.11.1*, 1.5.3, 1.7.11, 4.3.7, 5.3.7, annex K
 - contact gaps, CLEARANCES not applicable, 2.10.3.1, G.6
 - not to operate during heating tests, 4.5.1
- thickness (of insulation) *see* distance through insulation
- thin sheet insulating material, **2.10.5.2**, 2.10.5.3 (table 2M), 2.10.5.4, C.2

electric strength testing, 5.2.1

prepreg, layers counted before curing, 2.10.5.3 (table 2M)

three-phase

disconnect devices, 3.4.7

equipment

TOUCH CURRENT, 5.1.3 (figure 5B), 5.1.5, 5.1.7

protection, 2.7.4 (tables)

motors, B.9

power distribution systems, annex V

rotation, marking if critical, 1.7.7.2

TIME, RATED OPERATING, 1.2.2.2*, 1.7.3, 4.5.1, 5.3.7

TN power distribution systems, 1.6.1, 5.1, V.2

protective devices, 2.7.4 (tables)

TNV CIRCUITS, 1.2.8.9*, **2.3**

accessibility, 2.1.1.1, 2.1.2, 2.1.3

in battery compartments, 2.1.1.2

via other circuits, 6.2.1

boundaries of, 2.3.4

compared with SELV CIRCUITS, 1.2.8.9 (table 1A)

connected to SELV CIRCUITS, 2.3.2

connected to TELECOMMUNICATION NETWORKS, 1.4.11, **6.1.1**

connections to other circuits, 2.3.4

connections to other equipment, 3.5.1, 3.5.2

connectors, 4.3.5

considered to be SECONDARY CIRCUITS, 1.2.8.9

earth required, 2.6.1

FIRE ENCLOSURES not required, 1.4.11, 4.7.2.2

insulation, 2.9.5

maximum voltages, 2.3.1

separation

from accessible parts, 2.3.2

from HAZARDOUS VOLTAGES, 2.3.3

from SELV CIRCUITS and other TNV CIRCUITS, 2.3.2, 2.9.5 (table 2G)

WORKING VOLTAGE, 2.10.2, 2.10.3.2, 2.10.4

TNV-1 CIRCUITS, 1.2.8.10*, 2.3.1 a)

separation from parts of equipment, 6.2.1

treated as TNV-3 CIRCUITS, 2.3.2

TNV-2 CIRCUITS, 1.2.8.11*, 2.3.1 b)

treated as TNV-3 CIRCUITS, 2.3.2

TNV-3 CIRCUITS, 1.2.8.12*, 2.3.1 b)

separation from parts of equipment, 6.2.1

tolerances

frequency, 1.4.6

manufacturing, effect on CLEARANCES, 2.10.3.1 (note 6), G.6 (note 2)

voltage, 1.4.5

during TOUCH CURRENT tests, 5.1.3

TOOLS, 1.2.7.4*

not required for OPERATOR ACCESS AREAS, 1.2.7.1

required

for

access, 1.2.7.3, 1.7.16, 3.2.9

adjustment, 1.4.4, 4.3.3

replacement of special cords, 1.2.5.5

to

open battery compartments, 2.1.1.2

override interlocks, 2.8.6

remove bushings, 3.2.7

remove guards against water ingress, annex T

risk of short-circuits during servicing, 2.1.2

TOUCH CURRENT, 0.2.1, 1.2.13.12*, **5.1**, annexes D and W

high TOUCH CURRENT, 5.1.7, 5.1.8.2 a)

maximum, 5.1.6, 5.1.8.1, 5.1.8.2

measuring instruments, annex D

summation, 5.1.8.2, annex W

to and from TELECOMMUNICATION NETWORKS, 2.6.1 g), 2.6.3, **5.1.8**

tracking, 2.10.1, 2.10.4, annex P (IEC 60112)

transformers, 1.5.4, annex C

conductive foil as screens, C.2 (note)

cores, 2.9.5 (note to table 2G), C.2

enclosed, 2.10.7

ferro-resonant, C.1, annex X

in FIRE ENCLOSURE, 4.7.2.1

in TOUCH CURRENT testing, 5.1.3

insulation, 2.9.5, 2.10.2, **C.2**

 varying dimensions, 2.10.10, 5.2.2

isolating

 in limited power source, 2.5

 used for test, 5.1.3

maximum temperature, C.1, annex X

not in Scope of standard unless integral in equipment, 1.1.3

overload protection, 5.3.3, C.1, annex X

power distribution, V.1

screens *see* screens, conductive

signal, clause 6 (note 4), 6.2.2

tandem, 2.2.3.1

testing, 2.10.7, 5.3.6, C.1, annex X

winding wire *see* winding wire

WORKING VOLTAGES, 2.10.2

transient ratings (Overvoltage Category II), 2.10.3.2 (table 2H), 2.10.3.3 (table 2K)

transients

affecting WORKING VOLTAGE, 2.10.2

attenuated, 2.6.1 f), 2.10.3.4, G.5

disregarded for CREEPAGE DISTANCES, 2.10.4

in PRIMARY CIRCUITS, 1.2.9.9, 2.10.3.2, 2.10.3.3, G.2, G.4 a)

in SECONDARY CIRCUITS, 2.10.3.3, 2.10.5.1, G.4 a)

in TNV CIRCUITS, 1.2.8.10, 1.2.8.11, 1.2.8.12

not part of operating voltage, 1.4.8

internally generated, 2.10.3.3, G.4 a)

measurement in floating SECONDARY CIRCUITS, 2.10.3.4, G.5

non-repetitive, not affecting WORKING VOLTAGE, 2.10.3.2

ON TELECOMMUNICATION NETWORKS

see TELECOMMUNICATION NETWORK TRANSIENT VOLTAGES

simulated, annex N

see also impulse tests, MAINS TRANSIENT VOLTAGES, overvoltage categories

transport

castors, 1.2.3.1, 4.1

conditions during, 2.6.5.6, 2.10.3.1 (note 6), G.6 (note 2)

orientation, 1.3.6

precautions during, 1.7.2

TRANSPORTABLE EQUIPMENT, 1.2.3.3*, **4.6.4**

orientation, 1.3.6

TT power distribution systems, 1.6.1, S.1, V.3

protective devices, 2.7.4 (tables)

t.v. distribution systems, 1.2.13.8

TYPE TESTS, 1.2.13.1*, **1.4.2**, 1.5.2, U.2

U

ultraviolet radiation, 0.2.6, 4.3.13

unattended equipment, testing, 5.3.7

unearthed (floating), 2.10.1, 2.10.2, annex F (figure F.13)

ENCLOSURES, 4.2.1

meaning of term, 2.9.5 (note to table 2G), 2.10.2

neutral in 3-phase systems, 2.7.4 (table 2F)

parts and windings, 1.4.9, 2.10.1, 2.10.2, annex F (figure F.13)

accessibility, 2.1.1.1, 2.1.1.3, 2.1.1.4

and

TELECOMMUNICATION NETWORKS, 6.2.1

internal wiring, 2.1.1.3, 2.1.1.4

in determination of WORKING VOLTAGES, 2.10.2

separation, 2.1.1.1

from stranded wire, 3.3.8

TOUCH CURRENT tests, 5.1.5

within DOUBLE INSULATION, 2.9.5

SECONDARY CIRCUITS

treated as PRIMARY CIRCUITS, 2.10.3.3, 6.4

SELV CIRCUITS, 2.6.3.3, 2.9.5

uninsulated conductors and parts, 2.1.1.1, 3.2.9

see also bus-bars

USERS, 1.2.13.6*

see also OPERATORS *which has the same meaning*

V

vapour, 1.2.12.10, 4.3.12

vibration *see* mechanical shock

VOLTAGE, HAZARDOUS *see* HAZARDOUS VOLTAGE

VOLTAGE, RATED *see* RATED VOLTAGE

VOLTAGE, WORKING *see* WORKING VOLTAGE

VOLTAGE, REQUIRED WITHSTAND *see* REQUIRED WITHSTAND VOLTAGE

voltage(s)

equipment to be safe at any supply voltage, 1.3.3

generated externally, 1.4.8, 2.3.5

measurements to earth, 1.4.9

normal operating, 1.4.8

rating *see* rated voltage of components

r.m.s. values implied unless otherwise specified, 1.2

selectors, 1.7.1, 1.7.4, 4.3.3

SELV CIRCUITS and TNV CIRCUITS compared, 1.2.8.9 (note 2 and table 1A)

W

wall-mounted equipment, 1.2.3.5, 4.2.10, annex T

warning notices

examples for reduction of hazards, 0.1, 0.2.4, 0.2.5, 0.2.6, 0.2.7

high TOUCH CURRENT, 5.1.7, 5.1.8.2 a)

moving parts, 4.4.2

symbol, electric shock hazard, 1.7.16

temperature, 4.5.1 (table 4A item 6)

to SERVICE PERSONNEL, 1.7.9, 2.6.1, 2.7.6, 3.4.10

water ingress, 1.1.2, 2.10.7, 2.10.8, annex T

see also IEC 60529

weight *see* mass

wire, wiring, **Clause 3**

access to, in

ELV CIRCUITS, 2.1.1.3

HAZARDOUS VOLTAGE circuits, 2.1.1.4

fixed *see* fixing, parts, wiring

enamelled *see* enamel

equipment, 3.1.4

gauge (AWG, cmil), 2.6.3.2 (table 2D), 3.2.5 (table 3B)

insulation

colour, 2.6.3.4

flammability, 4.7.3.3, 4.7.3.4

in FIRE ENCLOSURES, 4.7.2.1, 4.7.2.2

resistance to oil, 4.3.9

over-current protection, **2.7**, 3.1.1

printed, 2.6.3.4, annex F (figure F.11)

sleeved *see* sleeving as additional insulation

telecommunication, 6.3

terminals *see* wiring terminals

termination, 3.1.9

temperature, 4.5.1

winding, 2.10.5.4, annex U

see also ampacity, building installations

wiring terminals, 2.6.4, **3.1**, 3.2.4, **3.3**

access, 3.2.9

ampacity, 2.6.4.1, 3.3.4, 3.3.5

corrosion, 2.6.5.6

grouping, 3.3.7

(main) protective earthing terminals, 1.2.13.10, 1.2.13.11, 1.4.9, 2.2.3.3, 2.3.2, 2.3.3, 2.6.1, 2.6.3.3, **2.6.4.1**, 2.6.4.2, 5.1.3, 5.1.6 (table 5A), 5.1.8.2

equipment with, 5.1.7, G.4 a), 5.1.8.1

equipment without, 5.1.8.1

of transformer, C.2

more than one, 2.6.4.1

marking

power supply, 1.7.7.2

protective earthing, 1.7.7.1

temperature, 4.5.1 (table 4A part 1)

wound components, 2.10.5.4, 5.3.5, annex U

see also motors *and* transformers

WORKING VOLTAGES, 1.2.9.6*

determination of, 1.4.8, **2.10.2**

for CLEARANCES in PRIMARY circuits, 2.10.3.2

for CLEARANCES in SECONDARY circuits 2.10.3.3

for CREEPAGE DISTANCES, 2.10.3.3, 2.10.4

for electric strength tests, 5.2.2

meaning, for DOUBLE INSULATION, 2.10.2

PEAK *see* PEAK WORKING VOLTAGE

to be considered, 2.9.1, 2.9.4

varying, 2.10.10

see also rated voltage of components

X

x-rays *see* ionizing radiation

No Text on This Page

Subjects 1950 (60950, 1459)
(In reply, refer to Subject 1950)

1655 Scott Blvd.
Santa Clara, CA 95050
July 23, 1999

TO: Industry Advisory Conference of Underwriters Laboratories for Information Technology and Telecommunications Equipment, Electrical Council of Underwriters Laboratories Inc. Subscribers to UL's Standards Service for Information Technology Equipment Telephone Equipment Subscribers to UL's Listing, Recognition, Classification, and Evaluation Services as Shown in Appendix A

SUBJECT: Effective Dates and Planned Industry Review Associated with the Standard for Safety of Information Technology Equipment, CSA C22.2 No. 950-95/UL 1950, Third Edition; and the Proposed Standard for Safety of Information Technology Equipment, CSA C22.2 No. 60950-xx/UL 60950, Third Edition

SUMMARY

For new product submittals through April 1, 2000, such products may be evaluated using all the requirements in UL 1950, Third Edition (or when published, UL 60950, Third Edition), or if requested in writing, evaluated using the requirements in other existing applicable standards for the products, such as UL 114, UL 478, UL 1459 or UL 1950 First or Second Editions. After April 1, 2000 all new product submittals must use either UL 1950, Third Edition, or UL 60950, Third Edition.

For new product submittals between April 1, 2000 and April 1, 2003, such products may be evaluated using all the requirements in UL 60950, Third Edition, or if requested in writing, evaluated using the requirements in UL 1950, Third Edition. After April 1, 2003 all new product submittals must use UL 60950, Third Edition.

Products that were previously certified by Underwriters Laboratories Inc. to requirements in other existing applicable standards, such as UL 114, UL 478, UL 1459, or UL 1950, First or Second Editions, through April 1, 2000, and UL 1950, Third Edition, through April 1, 2003, may continue to be certified without further reinvestigation until April 1, 2005, provided no significant changes or revisions are made to such products. Non-significant changes will be evaluated to the original standard.

As of April 1, 2005, all products, including those previously certified by UL, must comply with UL 60950, Third Edition in order to continue to have the UL Mark applied after this date. By this date, it is planned that all associated Subscriber files associated with EMRT, EMRT2, QAOT, QAOT2, QQBK2, QQHX2, QQJE2, WYQQ, WYQQ2 will be relocated under the renamed Listing/Recognition product categories for Information Technology and Telecommunications Equipment, NWGQ, NWGQ2, and Power Supplies, Information Technology and Telecommunications Equipment, QQQQ, QQQQ2.

As documented in Agenda Item 4 of the Subjects 1950 (1459) Meeting Report dated June 10, 1998 of the Meeting of the Industry Advisory Conference of UL for Information and Telecommunications Equipment, the Effective Dates associated with the full implementation of the Bi-National Standard are approaching. The ITE Industry has requested that UL issue a bulletin summarizing the impact of these

established Effective Dates. This bulletin summarizes the impact of both existing and pending Effective Dates associated with the proposed UL 60950, Third Edition. UL 60950, Third Edition was proposed in the Subjects 60950 (1950, 1459) Bulletin Dated June 30, 1999.

History

Prior to the introduction of UL 1950, three UL Standards were used to investigate electrical business, information technology, and telecommunications equipment: UL 478, the Standard for Electronic Data-Processing Units and Systems; UL 114, the Standard for Office Appliances and Business Equipment; and UL 1459, the Standard for Telephone Equipment.

In the mid-1980s, the ITE Industry requested that UL adopt an IEC-based harmonized standard for ITE, i.e., one based on IEC 950, Safety of Information Technology Equipment, Including Electrical Business Equipment. The First Edition of UL 1950 was published March 15, 1989, and its Scope included all information technology equipment and electrical business equipment. Telecommunications equipment, other than products with generic modems, were excluded from the Scope. During the preparation and planning for the introduction of UL 1950, First Edition UL partnered with the ITE Industry to permit manufacturers to continue to use traditional UL 478- and UL 114-based requirements until March 15, 2000 since the new IEC-based requirements were considered by some manufacturers a significant upgrade of existing designs. The result was the inclusion of Supplement C and its D3 Deviations in UL 1950, First Edition, which delayed the intended full implementation of the IEC-based standard until March 15, 2000.

Several years later and subsequent to a second edition of the Standard (UL 1950), as the technologies associated with IT and telecommunications equipment continued to merge, the IT and Telecommunications Industries again approached UL (and the Canadian Standards Association (CSA)) requesting that a U.S./Canadian IEC-based standard for both ITE and telecommunications equipment be developed. A collaborative effort between UL, CSA, and the IT and Telecommunications industries resulted in the Bi-National Standard, CSA C22.2 No. 950-95/UL 1950, Third Edition, the Standard for Safety of Information Technology Equipment, Including Electrical Business Equipment, which was published on July 28, 1995. As part of the preparation and planning of the introduction of this new standard, UL again partnered with the IT and Telecommunications industries to establish a new two-stage Effective Date for UL 1950 to allow manufacturers associated with both the IT and telecommunications sectors of Industry adequate time to plan, design, and manufacture products to the new Bi-National Standard. This two-stage UL Effective Date communicated in the Preface of UL 1950, Third Edition, states:

"Between July 28, 1995 and April 1, 2000, new product submittals may be evaluated using all the requirements in this standard (UL 1950, Third Edition), or if requested in writing, evaluated using the requirements in other existing applicable standards for the product.

After April 1, 2000, products that were previously evaluated by Underwriters Laboratories Inc. to the requirements in other existing applicable standards may continue to be (certified) until April 1, 2005 without further investigation, provided no significant changes or revisions are made to such products.

As of April 1, 2005, all products, including those previously evaluated by UL, must comply with this standard."

This two-stage Effective Date replaced and superseded the original March 15, 2000 Effective Date associated with UL 1950 First and Second Editions.

In December 1998, the Bi-National Working Group (BNWG) reviewed the recently published IEC 60950, Third Edition for adoption in the U.S. and Canada with appropriate National deviations. In the Subjects 60950 (1950, 1459) Bulletin dated June 30, 1999 a new Bi-National Standard, CSA C22.2 No. 60950-xx/UL 60950, Third Edition was proposed for adoption in the U.S. and Canada. Assuming the new Bi-National Standard is published during the first quarter of year 2000 as targeted, UL intends to adopt the following modified Effective Date Schedule associated with UL 60950, Third Edition, which again will be published in the Preface to the Standard:

For new product submittals, between [publication date] and April 1, 2000, such products may be evaluated using all the requirements in UL 60950, Third Edition, or if requested in writing, evaluated using the requirements in other existing applicable standards for the products, such as UL 114, UL 478, UL 1459 or UL 1950 First, Second, or Third Editions. After April 1, 2000 all new product submittals must use either this standard [UL 60950, Third Edition] or UL 1950, Third Edition.

For new product submittals between April 1, 2000 and April 1, 2003, such products may be evaluated using all the requirements in UL 60950, Third Edition, or if requested in writing, evaluated using the requirements in UL 1950, Third Edition. After April 1, 2003 all new product submittals must use UL 60950, Third Edition.

Products that were previously certified by Underwriters Laboratories Inc. to requirements in other existing applicable standards, such as UL 114, UL 478, UL 1459, or UL 1950, First or Second Editions through April 1, 2000, and UL 1950, Third Edition through April 1, 2003, may continue to be certified without further reinvestigation until April 1, 2005, provided no significant changes or revisions are made to such products. Non-significant changes will be evaluated to the original standard.

As of April 1, 2005, all products, including those previously certified by UL, must comply with UL 60950, Third Edition in order to continue to have the UL Mark applied after this date. As of April 1, 2005 the Bi-National Standard, CSA C22.2 No. 60950-xx/UL 60950, Third Edition will be the remaining standard available for investigation of information technology and telecommunications equipment in the U.S. and Canada.

Rationale for Industry Review

As indicated in the previously referenced Subjects 1950 (1459) IAC Meeting Report of June 10, 1998, the UL Mark on equipment represents that the equipment complies with the applicable and current UL Standard at the time it is subjected to Follow-Up Service at the manufacturing facility. An Industry Review is needed to establish one set of requirements for IT and Telecommunications equipment and a level playing field for all manufacturers; reduce unnecessary engineering/administrative work; facilitate the concept of one worldwide standard which the ITE Industry has been promoting for many years; promote products with the same level of safety available to consumers; and limit inquiries from Authorities Having Jurisdiction (AHJs) questioning to which standard the product was evaluated. While Effective Dates impact all equipment manufactured and marked with the UL Mark as of the Effective Date, Effective Dates do not impact Listed/Recognized equipment which have already been subjected to UL Follow-Up Service before the Effective Date (i.e., equipment in the field does not need to be retrofitted to comply with new requirements).

Impact of Industry Review

The following UL Standards will be eliminated and replaced by UL 60950, Third Edition as of April 1, 2005: UL 114, Fourth Edition, Office Appliances and Business Equipment; UL 478, Fourth Edition, Electronic Data-Processing Units and Systems; UL 1459, Third Edition, Telephone Equipment; and UL 1950, First, Second and Third Editions, Information Technology Equipment, Including Electrical Business Equipment.

As stated above, as of April 1, 2005, all products, including those previously certified by UL must comply with UL 60950, Third Edition in order to continue to have the UL Mark applied after this date. As of April 1, 2005 the Bi-National Standard, CSA C22.2 No. 60950-xx/UL 60950, Third Edition will be the remaining standard available for investigation of information and telecommunications equipment in the U.S. and Canada.

The following Listing categories will be eliminated as of April 1, 2005: Data Processing Equipment, Electronic (EMRT); Office Appliances and Business Equipment (QAOT); Power Supplies, Telephone (QQJE); Telephone Appliances and Equipment (WYQQ).

It is planned that the following Recognition categories will be eliminated as of April 1, 2005: Data Processing Equipment, Electronic (EMRT2); Office Appliances and Business Equipment (QAOT2); Power Supplies, Electronic Data Processing Equipment (QQBK2); Power Supplies, Office Appliances and Business Equipment (QQHX2); Power Supplies, Telephone (QQJE); Telephone Appliances and Equipment (WYQQ2).

As of April 1, 2005, it is planned that all Listings of IT and telecommunications equipment will be included in the renamed Listing categories of Information Technology and Telecommunications Equipment (NWGQ) or Power Supplies, Information Technology and Telecommunications Equipment (QQGQ), as appropriate.

As of April 1, 2005, it is planned that all Recognitions of IT and telecommunications equipment will be included in the renamed Recognition categories of Information Technology Equipment and Telecommunications Equipment (NWGQ2) or Power Supplies, Information Technology and Telecommunications Equipment (QQGQ2), as appropriate.

As of April 1, 2005, Listed equipment under NWGQ will no longer be required to have the identifier "UL 1950," "Information Technology Equipment," "NWGQ," "I.T.E.," or "Info. Tech. Equipment," as part of the Listing, as was required during the UL114/478 transition to UL 1950. As of April 1, 2005 only a single product identifier/name will be permitted, such as "ITE," "Copier," "Telephone," etc. This change will align NWGQ with other UL Listing categories and their requirements for communicating the UL Listing, i.e., UL Mark, "Listed," product name or identifier, and the UL FUS Control Number.

Implementation of the Review

The Industry Review associated with UL 60950, Third Edition will be implemented in three stages.

Stage 1 – April 1, 2000 Effective Date

New products submitted between the date of this bulletin (July 23, 1999) and April 1, 2000 may be evaluated using the requirements in either UL 60950, Third Edition, or UL 114, UL 478, UL 1459, or UL 1950 First, Second, or Third Editions. After April 1, 2000 all new products will be investigated for compliance with either UL 60950, Third Edition, or UL 1950, Third Edition. After April 1, 2000, products that were previously evaluated and certified by Underwriters Laboratories to the requirements in either

UL 114, UL 478, UL 1459, UL 1950 First, Second, or Third Editions may continue to be certified until April 1, 2005 without further investigation, provided that there are no significant changes or revisions made to such products.

The intent of this first stage of the staggered Effective Date implementation is to require that all new product designs submitted for certification after April 1, 2000, be evaluated to UL 1950, Third Edition or UL 60950, Third Edition. The intent is not to require existing certified products as of April 1, 2000, and unmodified products after April 1, 2000 to be subjected to any formal review or retest as a result of this stage.

Products not evaluated to UL 1950, Third Edition, or UL 60950, Third Edition, that are modified after April 1, 2000 may require re-evaluation to UL 1950 or UL 60950 if the basic product design is subjected to significant changes or revisions. For purposes of this Industry Review, "significant changes or revisions" which may require re-evaluation of an existing certified product include redesign of the basic product to the degree that major safety critical components are added. For example, incorporating a telecommunications modem into equipment originally certified without a modem would require investigation of the modem within the equipment to UL 60950, Third Edition. Likewise, upgrading the functionality of equipment to include redundant power supplies when redundancy was not part of the original design would require an investigation to the latest requirements. Alternate enclosure materials, non-safety critical components and similar construction changes would not require re-investigation to the latest requirements. The intent of this limitation is to prevent the promulgation of designs investigated to obsolete standards being added to existing UL Reports when there have been significant design changes made to the equipment and, in effect, the equipment is new equipment.

Regarding power supplies, after April 1, 2000 all new power supply designs submitted for certification will be required to comply with either UL 1950, Third Edition, or UL 60950, Third Edition. However, as indicated in Annex P.2 of UL 1950, Third Edition, power supplies complying with the First or Second Editions of UL 1950 and that were certified without the use of Supplement C D3 Deviations may continue to be used in end use equipment certified in UL 1950, Third Edition until April 1, 2005. Power supplies investigated to earlier editions of UL 1950 are considered acceptable in UL 1950, Third Edition or UL 60950, Third Edition certifications because, although some requirements have changed, the key safety-critical UL 1950 requirements applicable to power supplies have not changed since the First Edition of UL 1950.

Telecommunications component manufacturers, in particular manufacturers of telecommunication modems, signal transformers and similar telecommunication components intended to be connected to outside plant may be particularly impacted by the April 1, 2000 Effective Date. Since telecommunications components submitted for certification after April 1, 2000 will be required to comply with UL 1950 Third Edition, or UL 60950, Third Edition, and Clause 6 has some important upgrades to requirements in previous editions of the Standard, telecommunications component manufacturers with certifications to either UL 114, UL 478, UL 1459 or UL 1950 First or Second Editions should give special consideration to the April 1, 2000 Effective Date and its impact on their business.

Stage 2 – April 1, 2003 Effective Date

New products submitted between April 1, 2000 and April 1, 2003 may be evaluated using the requirements in either UL 1950, Third Edition or UL 60950, Third Edition. After April 1, 2003 all new products will be investigated for compliance with UL 60950 Third Edition. After April 1, 2003, products that were previously evaluated by Underwriters Laboratories to the requirements in UL 114, UL 478, UL 1459, UL 1950 First, Second or Third Editions may continue to be certified until April 1, 2005 without further investigation, provided that there are no significant changes or revisions made to such products.

The intent of this second stage of the staggered Effective Date implementation is to require that all new product designs submitted for certification after April 1, 2003, be evaluated to UL 60950, Third Edition. The intent is not to require existing certified products as of April 1, 2003, and unmodified products after April 1, 2003 to be subjected to any formal review or retest during this second stage.

Products not evaluated to UL 60950 Third Edition that are modified after April 1, 2003 may require re-evaluation if the basic product design is subjected to significant changes or revisions. "Significant changes or revisions" are explained above.

Stage 3 – April 1, 2005 Effective Date

All products submitted after April 1, 2005 will be required to comply with UL 60950 Third Edition. The UL Standards UL 114, UL 478, UL 1459, and UL 1950 First, Second and Third Editions will be formally withdrawn as of this date and will not be able to be used for equipment certifications. **Additionally, by April 1, 2005, products that were previously evaluated by Underwriters Laboratories to the requirements in either UL 114, UL 478, or UL 1459, or UL 1950 First, Second or Third Editions, and that will continue to be manufactured and marked with the UL Mark after April 1, 2005, also will be required to be reinvestigated to determine that they comply with UL 60950 Third Edition. After April 1, 2005 the only UL Standard available to investigate information technology and telecommunications equipment will be UL 60950, Third (or any subsequent) Edition.** (When published, UL 60950, Third Edition will be based on IEC 60950, Third Edition.)

The Stage 3 April 1, 2005 Effective Date will require all IT and telecommunications equipment associated with EMRT, EMRT2, QAOT, QAOT2, QQBK2, QQHX2, WYQQ, and WYQQ2 categories to be re-investigated to UL 60950, Third Edition if the equipment has not already been investigated to that standard. Additionally, all IT and telecommunications equipment associated with NWWGQ, NWWGQ2, QQQQ, and QQQQ2 previously evaluated to UL 1950 First, Second, or Third Editions will be re-investigated to UL 60950, Third Edition.

The impact of the Stage 3 Industry Review on manufacturers could be significant if there is not adequate planning and preparation for the transition. To help facilitate an effective and efficient review UL intends to adopt the following strategy:

- IT and telecommunications manufacturers of components and equipment are encouraged to review and consider the impact of the pending Effective Dates on their products. Factors to consider are:

Are the impacted products end use IT/Telecommunications equipment (Listed) or are they IT/Telecommunications components (Recognized)?

Which equipment and/or components will be manufactured after April 1, 2000, and which may be upgraded or modified after that date?

Which equipment and/or components will be manufactured after April 1, 2003, and which may be upgraded or modified after that date?

Which components will be sold to OEMs after April 1, 2000 who will be required to comply with UL 1950, Third Edition?

Which components will be sold to OEMs after April 1, 2003 who will be required to comply with UL 60950, Third Edition?

Which equipment and/or components will continue to be manufactured after April 1, 2005?

- In the year 2000 – 2001 time frame, UL will distribute a general comparison document outlining the major safety-critical differences between UL 60950, Third Edition, and previous IT/Telecommunications standards which will be subjected to review.
- UL intends to begin the communication and implementation of the Stage 3 Industry Review in the year 2002 time frame to allow sufficient time for all manufacturers to have their impacted equipment re-investigated before the April 1, 2005 Effective date.
- Main implementation of the Stage 3 Industry Review will be conducted through correspondence with implementation tools such as questionnaires and checklists to help reduce the burden of the Review on manufacturers and UL staff.
- The Review will concentrate on key differences between pre-UL 60950 Third Edition Standards and UL 60950 Third Edition, such as levels of protection against electric shock (e.g., SELV) and connection to telecommunication networks. It is anticipated that the Review will not encompass a sub-clause by sub-clause comparison of the equipment to UL 60950 Third Edition when sound assumptions can be made on reviewed constructions. For example, for a personal computer with an internal modem that has been previously certified to either the First or Second Editions of UL 1950 and will continue to be manufactured after April 1, 2005, the extent of the review may be to confirm that the equipment now incorporates a power supply and modem which now both comply with UL 60950, Third Edition.
- On April 1, 2005 UL intends to withdraw authorization to apply the UL Mark for all previously certified products which have not been investigated to UL 60950 Third Edition requirements prior to that date.

Considering the above Effective Date schedule, UL recommends that manufacturers begin considering the implications of the UL 1950 and UL 60950 Effective Dates on existing product lines. Proactively developing an internal plan which considers the need to either withdraw UL certification or re-investigate your product line will help to reduce the potential impact of the Industry Review.

Any questions or comments on the above are welcome and may be directed to your local engineering service provider or the undersigned. Please see Appendix B of this bulletin regarding designated responsibility for the subject product categories.

UNDERWRITERS LABORATORIES INC.

REVIEWED BY:

THOMAS M. BURKE (Ext. 32286)
Senior Staff Engineer
Engineering Services 3013HSCL

KEVIN L. RAVO (Ext.32311)
ITE Business Sector Coordinator
Engineering Services 5014XSCL

1950____.7NE

APPENDIX A**LISTING, RECOGNITION, CLASSIFICATION, AND EVALUATION SERVICES FROM ADDRESSEE LIST**

Subscribers to UL's Listing Services for:

- Data Processing Equipment, Electronic (EMRT);
- Information Technology Equipment Including Electrical Business Equipment (NWGQ);
- Office Appliances and Business Equipment (QAOT);
- Power Supplies, Information Technology Equipment Including Electrical Business Equipment (QQGQ);
- Power Supplies, Telephone (QQJE);
- Telephone Appliances and Equipment (WYQQ)

Subscribers to UL's Recognition Services for:

- Data Processing Equipment, Electronic (EMR2T);
- Information Technology Equipment Including Electrical Business Equipment (NWGQ2);
- Office Appliances and Business Equipment (QAOT2);
- Power Supplies, Electronic Data Processing Equipment (QQBK2);
- Power Supplies, Information Technology Equipment Including Electrical Business Equipment (QQGQ2);
- Power Supplies, Office Appliances and Business Equipment (QQHX2);
- Power Supplies, Telephone (QQJE2)
- Telephone Appliances and Equipment (WYQQ2)

Subscribers to UL's Classification Services for:

- Data Processing Equipment, Electronic, Classified in Accordance with International Publications (ENMQ);
- Information Technology Equipment Including Electrical Business Equipment, Classified in Accordance with International Publications (NWNX);
- Office Appliances and Business Equipment, Classified in Accordance with International Publications (QARX)

Subscribers to UL's Evaluation Services for:

Data Processing Equipment, Electronic, Classified in Accordance with International Publications (ENMQ2);

Information Technology Equipment Including Electrical Business Equipment, Classified in Accordance with International Publications (NWNX2);

APPENDIX B**DESIGNATED RESPONSIBILITY FOR UL PRODUCT CATEGORIES**

NWGQ, INFORMATION TECHNOLOGY EQUIPMENT INCLUDING ELECTRICAL BUSINESS EQUIPMENT
 QQQQ, POWER SUPPLIES, INFORMATION TECHNOLOGY EQUIPMENT INCLUDING ELECTRICAL BUSINESS EQUIPMENT
 WYQQ, TELEPHONE APPLIANCES AND EQUIPMENT

The individuals shown in the following tables are involved with the investigation of products covered under the subject categories. The Primary Designated **Engineer (shown in UPPERCASE letters)** coordinates the establishment and uniform interpretation of UL requirements applicable to the product categories. The Designated Engineers (**shown in lowercase letters**) work with the Primary Designated Engineer to interpret requirements and maintain standards.

Should you have questions regarding the interpretation of the requirements proposed in this bulletin or any adopted requirements that affect your product, you are encouraged to contact the individual at the office to which you normally submit your products.

The Industry Advisory Conference (IAC) Chairman for the subject categories is Kevin Ravo at UL's Santa Clara office. The IAC Chairman oversees the significant interpretations made by the Primary Designated Engineer and arbitrates any differences regarding interpretation of UL requirements.

CCN	Office/Subsidiary	Responsible Engineer	Extension
NWGQ	Camas	Larry Copley	55612
	Melville	Rich Fardellone	22457
	Northbrook	Ken Boyce	42318
	RTP	Mark Walker	11557
	Santa Clara	TOM BURKE	32286
	Europe	Ramon Torres	49-69-8306-467
	Hong Kong	C. C. Chan	852-2695-9599
	India	K. Y. Rajaram	91-80-558-1773
	Japan	I. Kinno	81-3-3571-3188
	Korea	Azim Karimi	82-2-739-7346
	Taiwan	A. Chien	886-2-2896-7790
	DEMKO	Walid Beytoughan	45-44-85-6565

CCN	Office/Subsidiary	Responsible Engineer	Extension
QQGQ	Camas	Scott Varner	55613
	Melville	Annemarie Vessey	22690
	Northbrook	Raymond Stanko	43328
	RTP	MARK WALKER	11557
	Santa Clara	Paul Grabowski	32449
	Europe	Ramon Torres	49-69-8306-467
	Hong Kong	C. C. Chan	852-2695-9599
	Japan	I. Kinno	81-3-3571-3188
	Korea	Azim Karimi	82-2-739-7346
	Taiwan	A. Chien	886-2-2896-7790
	DEMKO	Walid Beytoughan	45-44-85-6565

CCN	Office/Subsidiary	Responsible Engineer	Extension
WYQQ	Camas	Larry Copley	55612
	Melville	RANDY IVANS	22269
	Northbrook	Jim Murphy	42617
	RTP	Mark Vlanich	11674
	Santa Clara	Anh Nguyen	32524
	Europe	Ramon Torres	49-69-8306-467
	Hong Kong	M. Chow	852-2695-9599
	Japan	I. Kinno	81-3-3571-3188
	Taiwan	G. Wang	886-2-2896-7790

No Text on This Page