

LM1086

1.5A Low Dropout Positive Regulators

General Description

The LM1086 is a series of low dropout positive voltage regulators with a maximum dropout of 1.5V at 1.5A of load current. It has the same pin-out as National Semiconductor's industry standard LM317.

The LM1086 is available in an adjustable version, which can set the output voltage with only two external resistors. It is also available in five fixed voltages: 2.5V, 2.85V, 3.3V, 3.45V and 5.0V. The fixed versions integrate the adjust resistors.

The LM1086 circuit includes a zener trimmed bandgap reference, current limiting and thermal shutdown.

The LM1086 series is available in TO-220 and TO-263 packages. Refer to the LM1084 for the 5A version, and the LM1085 for the 3A version.

Features

- Available in 2.5V, 2.85V, 3.3V, 3.45V, 5V and Adjustable Versions
- Current Limiting and Thermal Protection
- Output Current 1.5A
- Line Regulation 0.015% (typical)
- Load Regulation 0.1% (typical)

Applications

- SCSI-2 Active Terminator
- High Efficiency Linear Regulators
- Battery Charger
- Post Regulation for Switching Supplies
- Constant Current Regulator
- Microprocessor Supply

Connection Diagrams

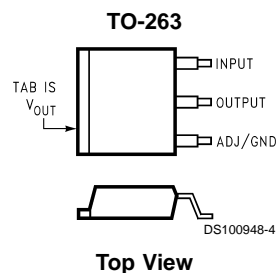
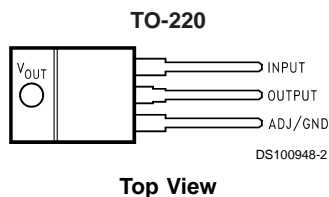

Basic Functional Diagram, Adjustable Version

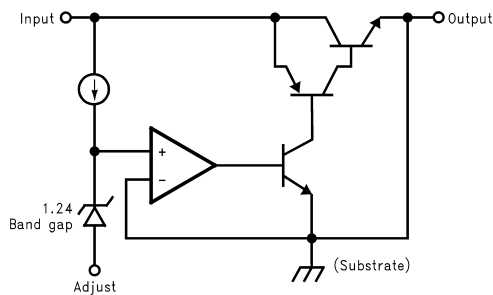

Application Circuit

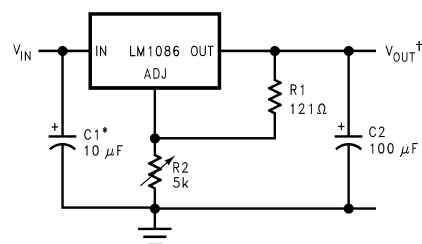

*NEEDED IF DEVICE IS FAR FROM FILTER CAPACITORS

$$V_{OUT} = 1.25V \left(1 + \frac{R2}{R1}\right)$$

DS100948-52

1.2V to 15V Adjustable Regulator

Ordering Information

| Package | Temperature Range | Part Number | Transport Media | NSC Drawing |
|---------------|-------------------|----------------|-----------------|-------------|
| 3-lead TO-263 | -40°C to +125°C | LM1086IS-ADJ | Rails | TS3B |
| | | LM1086ISX-ADJ | Tape and Reel | |
| | | LM1086IS-2.85 | Rails | |
| | | LM1086ISX-2.85 | Tape and Reel | |
| | | LM1086IS-3.3 | Rails | |
| | | LM1086ISX-3.3 | Tape and Reel | |
| | | LM1086IS-3.45 | Rails | |
| | | LM1086ISX-3.45 | Tape and Reel | |
| | | LM1086IS-5.0 | Rails | |
| | | LM1086ISX-5.0 | Tape and Reel | |
| | 0°C to +125°C | LM1086CS-ADJ | Rails | |
| | | LM1086CSX-ADJ | Tape and Reel | |
| | | LM1086CS-2.5 | Rails | |
| | | LM1086CSX-2.5 | Tape and Reel | |
| | | LM1086CS-2.85 | Rails | |
| | | LM1086CSX-2.85 | Tape and Reel | |
| | | LM1086CS-3.3 | Rails | |
| | | LM1086CSX-3.3 | Tape and Reel | |
| | | LM1086CS-5.0 | Rails | |
| | | LM1086CSX-5.0 | Tape and Reel | |
| 3-lead TO-220 | -40°C to +125°C | LM1086IT-ADJ | Rails | T03B |
| | | LM1086IT-2.85 | Rails | |
| | | LM1086IT-3.3 | Rails | |
| | | LM1086IT-5.0 | Rails | |
| | 0°C to +125°C | LM1086CT-ADJ | Rails | |
| | | LM1086CT-2.85 | Rails | |
| | | LM1086CT-3.3 | Rails | |
| | | LM1086CT-5.0 | Rails | |

Simplified Schematic

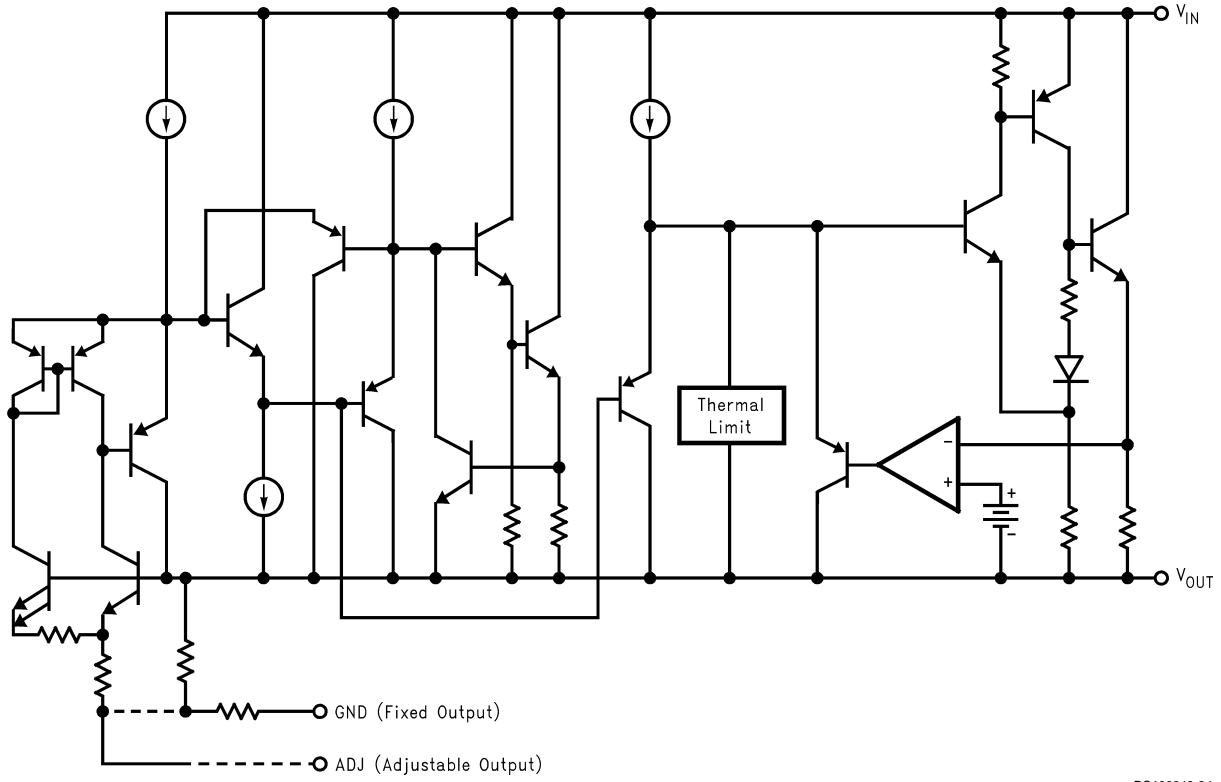

DS100948-34

Absolute Maximum Ratings (Note 1)

If Military/Aerospace specified devices are required, please contact the National Semiconductor Sales Office/Distributors for availability and specifications.

| | |
|--|--------------------|
| Maximum Input-to-Output Voltage Differential | |
| LM1086-ADJ | 29V |
| LM1086-2.5 | 27V |
| LM1086-2.85 | 27V |
| LM1086-3.3 | 27V |
| LM1086-3.45 | 27V |
| LM1086-5.0 | 25V |
| Power Dissipation (Note 2) | Internally Limited |
| Junction Temperature (T _J)(Note 3) | 150°C |

| | |
|---------------------------|------------------|
| Storage Temperature Range | -65°C to 150°C |
| Lead Temperature | 260°C, to 10 sec |
| ESD Tolerance (Note 4) | 2000V |

Operating Ratings (Note 1)

| | |
|---|----------------|
| Junction Temperature Range (T _J) (Note 3) | |
| "C" Grade | |
| Control Section | 0°C to 125°C |
| Output Section | 0°C to 150°C |
| "I" Grade | |
| Control Section | -40°C to 125°C |
| Output Section | -40°C to 150°C |

Electrical Characteristics

Typicals and limits appearing in normal type apply for T_J = 25°C. Limits appearing in **Boldface** type apply over the entire junction temperature range for operation.

| Symbol | Parameter | Conditions | Min (Note 6) | Typ (Note 5) | Max (Note 6) | Units |
|---|-----------------------------|--|-----------------------|-----------------------|-----------------------|----------|
| V _{REF} | Reference Voltage | LM1086-ADJ | | | | |
| | | I _{OUT} = 10mA, V _{IN} -V _{OUT} = 3V 10mA ≤ I _{OUT} ≤ I _{FULL LOAD} , 1.5V ≤ V _{IN} -V _{OUT} ≤ 15V (Note 7) | 1.238 1.225 | 1.250 1.250 | 1.262 1.270 | V V |
| V _{OUT} | Output Voltage (Note 7) | LM1086-2.5 | | | | |
| | | I _{OUT} = 0mA, V _{IN} = 5V 0 ≤ I _{OUT} ≤ I _{FULL LOAD} , 4.0V ≤ V _{IN} ≤ 18V | 2.475 2.450 | 2.50 2.50 | 2.525 2.55 | V V |
| | | LM1086-2.85 | | | | |
| | | I _{OUT} = 0mA, V _{IN} = 5V 0 ≤ I _{OUT} ≤ I _{FULL LOAD} , 4.35V ≤ V _{IN} ≤ 18V | 2.82 2.79 | 2.85 2.85 | 2.88 2.91 | V V |
| | | LM1086-3.3 | | | | |
| | | I _{OUT} = 0mA, V _{IN} = 5V 0 ≤ I _{OUT} ≤ I _{FULL LOAD} , 4.75V ≤ V _{IN} ≤ 18V | 3.267 3.235 | 3.300 3.300 | 3.333 3.365 | V V |
| ΔV _{OUT} | Line Regulation (Note 8) | LM1086-ADJ | | | | |
| | | I _{OUT} = 10mA, 1.5V ≤ (V _{IN} -V _{OUT}) ≤ 15V | | 0.015 0.035 | 0.2 0.2 | % % |
| | | LM1086-2.5 | | | | |
| | | I _{OUT} = 0mA, 4.0V ≤ V _{IN} ≤ 18V | | 0.3 0.6 | 6 6 | mV mV |
| | | LM1086-2.85 | | | | |
| | | I _{OUT} = 0mA, 4.35V ≤ V _{IN} ≤ 18V | | 0.3 0.6 | 6 6 | mV mV |
| LM1086-3.3 | | | | | | |
| I _{OUT} = 0mA, 4.5V ≤ V _{IN} ≤ 18V | | 0.5 1.0 | 10 10 | mV mV | | |
| LM1086-3.45 | | | | | | |
| I _{OUT} = 0mA, 4.95V ≤ V _{IN} ≤ 18V | | 0.5 1.0 | 10 10 | mV mV | | |
| LM1086-5.0 | | | | | | |
| I _{OUT} = 0mA, 6.5V ≤ V _{IN} ≤ 20V | | 0.5 1.0 | 10 10 | mV mV | | |

Electrical Characteristics (Continued)

Typicals and limits appearing in normal type apply for $T_J = 25^\circ\text{C}$. Limits appearing in **Boldface** type apply over the entire junction temperature range for operation.

| Symbol | Parameter | Conditions | Min (Note 6) | Typ (Note 5) | Max (Note 6) | Units |
|------------------|--|---|-----------------|-------------------|-------------------|--------------------|
| ΔV_{OUT} | Load Regulation (Note 8) | LM1086-ADJ $(V_{IN}-V_{OUT}) = 3V, 10mA \leq I_{OUT} \leq I_{FULL\ LOAD}$ | | 0.1 0.2 | 0.3 0.4 | % % |
| | | LM1086-2.5/2.85 $V_{IN} = 5V, 0 \leq I_{OUT} \leq I_{FULL\ LOAD}$ | | 3 6 | 12 20 | mV mV |
| | | LM1086-3.3/3.45 $V_{IN} = 5V, 0 \leq I_{OUT} \leq I_{FULL\ LOAD}$ | | 3 7 | 15 25 | mV mV |
| | | LM1086-5.0 $V_{IN} = 8V, 0 \leq I_{OUT} \leq I_{FULL\ LOAD}$ | | 5 10 | 20 35 | mV mV |
| | Dropout Voltage (Note 9) | LM1086-2.5/2.85/3.3/3.45/5/ADJ $\Delta V_{REF} = 1\%, I_{OUT} = 1.5A$ | | 1.3 | 1.5 | V |
| I_{LIMIT} | Current Limit | LM1086-ADJ $V_{IN}-V_{OUT} = 5V$ | 1.50 | 2.7 | | A |
| | | $V_{IN}-V_{OUT} = 25V$ | 0.05 | 0.15 | | A |
| | | LM1086-2.5, $V_{IN} = 8V$ | 1.5 | 2.7 | | A |
| | | LM1086-2.85, $V_{IN} = 8V$ | 1.5 | 2.7 | | A |
| | | LM1086-3.3, $V_{IN} = 8V$ | 1.5 | 2.7 | | A |
| | | LM1086-3.45, $V_{IN} = 8V$ | 1.5 | 2.7 | | A |
| | Minimum Load Current (Note 10) | LM1086-ADJ $V_{IN} - V_{OUT} = 25V$ | | 5.0 | 10.0 | mA |
| | Quiescent Current | LM1086-2.5, $V_{IN} \leq 18V$ | | 5.0 | 10.0 | mA |
| | | LM1086-2.85, $V_{IN} \leq 18V$ | | 5.0 | 10.0 | mA |
| | | LM1086-3.3, $V_{IN} \leq 18V$ | | 5.0 | 10.0 | mA |
| | | LM1086-3.45, $V_{IN} \leq 18V$ | | 5.0 | 10.0 | mA |
| | | LM1086-5.0, $V_{IN} \leq 20V$ | | 5.0 | 10.0 | mA |
| | Thermal Regulation | $T_A = 25^\circ\text{C}$, 30ms Pulse | | 0.008 | 0.04 | %/W |
| | Ripple Rejection | $f_{RIPPLE} = 120\text{Hz}, C_{OUT} = 25\mu\text{F Tantalum}, I_{OUT} = 1.5A$ | | | | |
| | | LM1086-ADJ, $C_{ADJ} = 25\mu\text{F}, (V_{IN}-V_O) = 3V$ | 60 | 75 | | dB |
| | | LM1086-2.5, $V_{IN} = 6V$ | 60 | 72 | | dB |
| | | LM1086-2.85, $V_{IN} = 6V$ | 60 | 72 | | dB |
| | | LM1086-3.3, $V_{IN} = 6.3V$ | 60 | 72 | | dB |
| | | LM1086-3.45, $V_{IN} = 6.3V$ | 60 | 72 | | dB |
| | | LM1086-5.0 $V_{IN} = 8V$ | 60 | 68 | | dB |
| | Adjust Pin Current | LM1086 | | 55 | 120 | μA |
| | Adjust Pin Current Change | $10mA \leq I_{OUT} \leq I_{FULL\ LOAD}, 1.5V \leq (V_{IN}-V_{OUT}) \leq 15V$ | | 0.2 | 5 | μA |
| | Temperature Stability | | | 0.5 | | % |
| | Long Term Stability | $T_A = 125^\circ\text{C}$, 1000Hrs | | 0.3 | 1.0 | % |
| | RMS Noise (% of V_{OUT}) | $10\text{Hz} \leq f \leq 10\text{kHz}$ | | 0.003 | | % |
| θ_{JC} | Thermal Resistance Junction-to-Case | 3-Lead TO-263: Control Section/Output Section | | | 1.5/4.0 | $^\circ\text{C/W}$ |
| | | 3-Lead TO-220: Control Section/Output Section | | | 1.5/4.0 | $^\circ\text{C/W}$ |

Note 1: Absolute Maximum Ratings indicate limits beyond which damage to the device may occur. Operating Ratings indicate conditions for which the device is intended to be functional, but specific performance is not guaranteed. For guaranteed specifications and the test conditions, see the Electrical Characteristics.

Note 2: Power dissipation is kept in a safe range by current limiting circuitry. Refer to Overload Recovery in Application Notes.

Note 3: The maximum power dissipation is a function of $T_{J(max)}$, θ_{JA} , and T_A . The maximum allowable power dissipation at any ambient temperature is $P_D = (T_{J(max)} - T_A) / \theta_{JA}$. All numbers apply for packages soldered directly into a PC board. Refer to Thermal Considerations in the Application Notes.

Note 4: For testing purposes, ESD was applied using human body model, 1.5k Ω in series with 100pF.

Electrical Characteristics (Continued)

Note 5: Typical Values represent the most likely parametric norm.

Note 6: All limits are guaranteed by testing or statistical analysis.

Note 7: $I_{FULL\ LOAD}$ is defined in the current limit curves. The $I_{FULL\ LOAD}$ Curve defines current limit as a function of input-to-output voltage. Note that 15W power dissipation for the LM1086 is only achievable over a limited range of input-to-output voltage.

Note 8: Load and line regulation are measured at constant junction temperature, and are guaranteed up to the maximum power dissipation of 15W. Power dissipation is determined by the input/output differential and the output current. Guaranteed maximum power dissipation will not be available over the full input/output range.

Note 9: Dropout voltage is specified over the full output current range of the device.

Note 10: The minimum output current required to maintain regulation.

Typical Performance Characteristics

Dropout Voltage vs Output Current

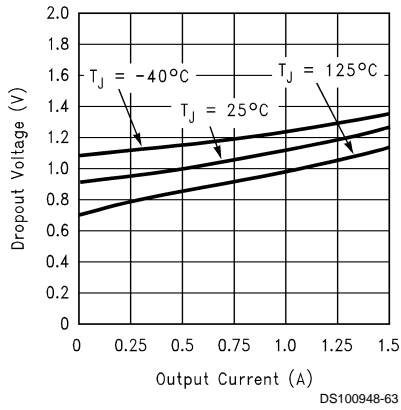

Short-Circuit Current vs Input/Output Difference

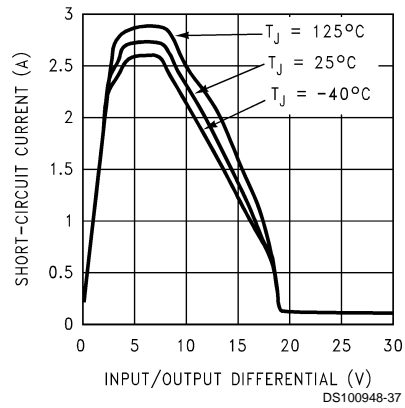

Load Regulation vs Temperature

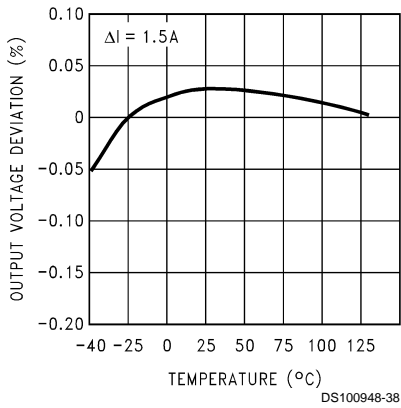

Percent Change in Output Voltage vs Temperature

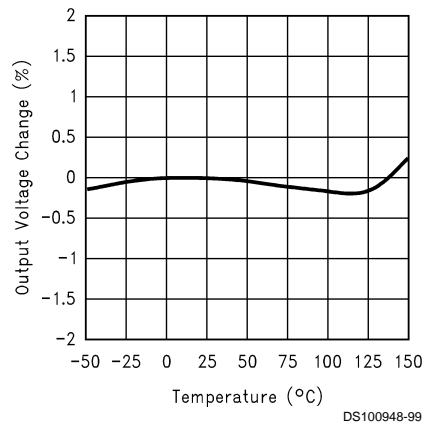

Typical Performance Characteristics (Continued)

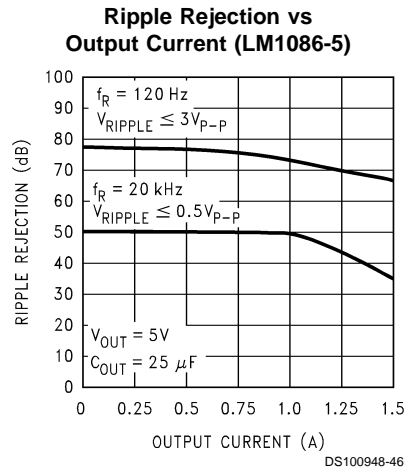
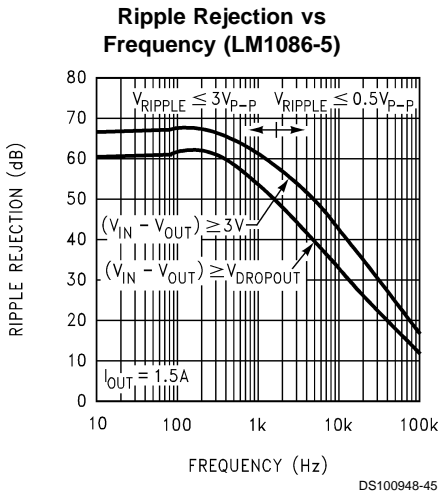
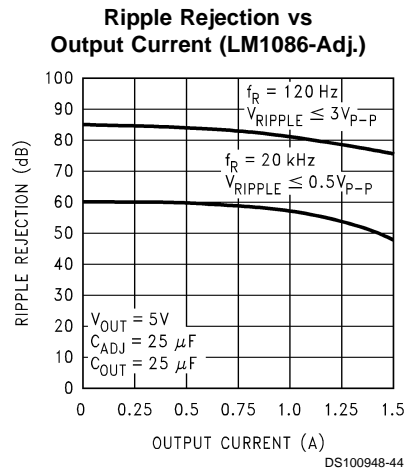
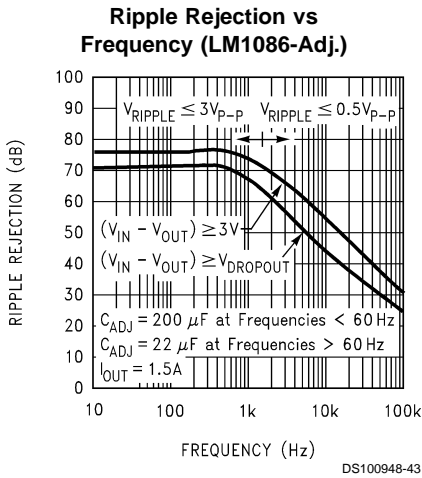
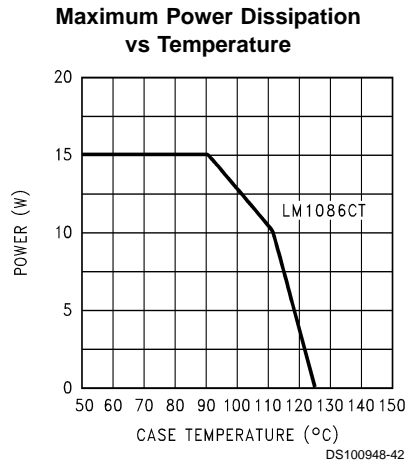
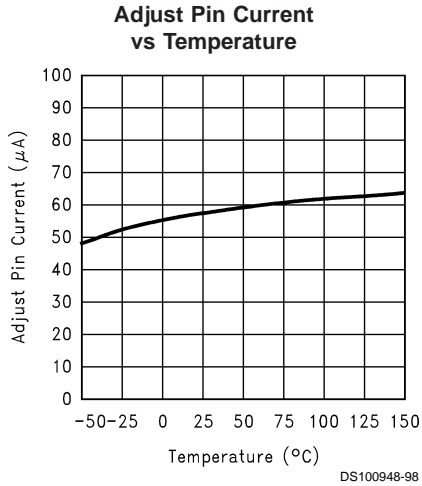

Typical Performance Characteristics (Continued)

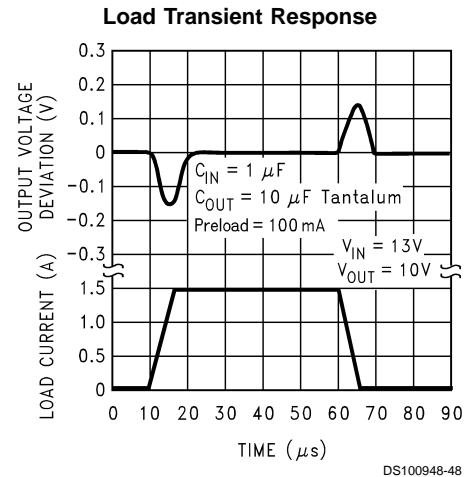
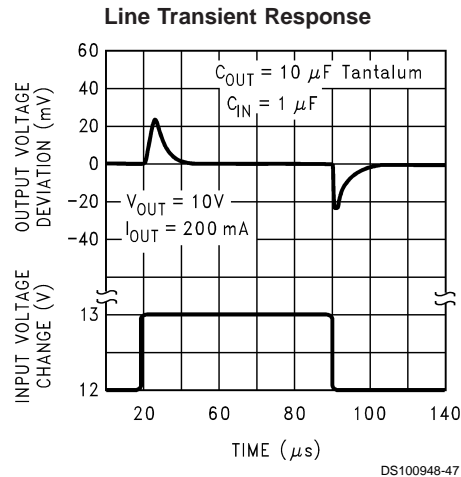

APPLICATION NOTE

General

Figure 1 shows a basic functional diagram for the LM1086-Adj (excluding protection circuitry). The topology is basically that of the LM317 except for the pass transistor. Instead of a Darlington NPN with its two diode voltage drop, the LM1086 uses a single NPN. This results in a lower dropout voltage. The structure of the pass transistor is also known as a quasi LDO. The advantage a quasi LDO over a PNP LDO is its inherently lower quiescent current. The LM1086 is guaranteed to provide a minimum dropout voltage 1.5V over temperature, at full load.

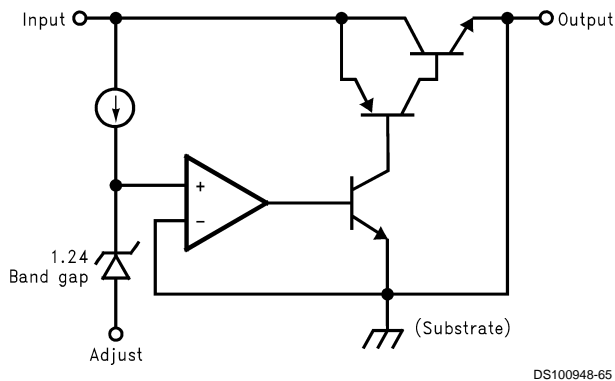

FIGURE 1. Basic Functional Diagram for the LM1086, excluding Protection circuitry

Output Voltage

The LM1086 adjustable version develops at 1.25V reference voltage, (V_{REF}), between the output and the adjust terminal. As shown in figure 2, this voltage is applied across resistor R1 to generate a constant current I1. This constant current then flows through R2. The resulting voltage drop across R2 adds to the reference voltage to sets the desired output voltage.

The current I_{ADJ} from the adjustment terminal introduces an output error. But since it is small (120uA max), it becomes negligible when R1 is in the 100 Ω range.

For fixed voltage devices, R1 and R2 are integrated inside the devices.

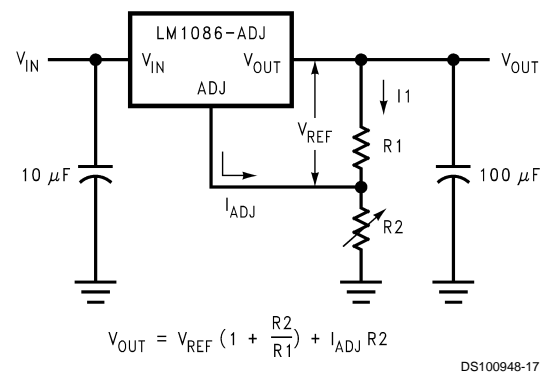

FIGURE 2. Basic Adjustable Regulator

Stability Consideration

Stability consideration primarily concern the phase response of the feedback loop. In order for stable operation, the loop must maintain negative feedback. The LM1086 requires a certain amount series resistance with capacitive loads. This series resistance introduces a zero within the loop to increase phase margin and thus increase stability. The equivalent series resistance (ESR) of solid tantalum or aluminum electrolytic capacitors is used to provide the appropriate zero (approximately 500 kHz).

The Aluminum electrolytic are less expensive than tantalums, but their ESR varies exponentially at cold temperatures; therefore requiring close examination when choosing the desired transient response over temperature. Tantalums are a convenient choice because their ESR varies less than 2:1 over temperature.

The recommended load/decoupling capacitance is a 10uF tantalum or a 50uF aluminum. These values will assure stability for the majority of applications.

The adjustable versions allows an additional capacitor to be used at the ADJ pin to increase ripple rejection. If this is done the output capacitor should be increased to 22uF for tantalums or to 150uF for aluminum.

APPLICATION NOTE (Continued)

Capacitors other than tantalum or aluminum can be used at the adjust pin and the input pin. A 10 μ F capacitor is a reasonable value at the input. See Ripple Rejection section regarding the value for the adjust pin capacitor.

It is desirable to have large output capacitance for applications that entail large changes in load current (microprocessors for example). The higher the capacitance, the larger the available charge per demand. It is also desirable to provide low ESR to reduce the change in output voltage:

$$\Delta V = \Delta I \times \text{ESR}$$

It is common practice to use several tantalum and ceramic capacitors in parallel to reduce this change in the output voltage by reducing the overall ESR.

Output capacitance can be increased indefinitely to improve transient response and stability.

Ripple Rejection

Ripple rejection is a function of the open loop gain within the feed-back loop (refer to *Figure 1* and *Figure 2*). The LM1086 exhibits 75dB of ripple rejection (typ.). When adjusted for voltages higher than V_{REF} , the ripple rejection decreases as function of adjustment gain: $(1+R1/R2)$ or V_O/V_{REF} . Therefore a 5V adjustment decreases ripple rejection by a factor of four (-12dB); Output ripple increases as adjustment voltage increases.

However, the adjustable version allows this degradation of ripple rejection to be compensated. The adjust terminal can be bypassed to ground with a capacitor (C_{ADJ}). The impedance of the C_{ADJ} should be equal to or less than $R1$ at the desired ripple frequency. This bypass capacitor prevents ripple from being amplified as the output voltage is increased.

$$1/(2\pi * f_{RIPPLE} * C_{ADJ}) \leq R1$$

Load Regulation

The LM1086 regulates the voltage that appears between its output and ground pins, or between its output and adjust pins. In some cases, line resistances can introduce errors to the voltage across the load. To obtain the best load regulation, a few precautions are needed.

Figure 3 shows a typical application using a fixed output regulator. R_{t1} and R_{t2} are the line resistances. V_{LOAD} is less than the V_{OUT} by the sum of the voltage drops along the line resistances. In this case, the load regulation seen at the R_{LOAD} would be degraded from the data sheet specification. To improve this, the load should be tied directly to the output terminal on the positive side and directly tied to the ground terminal on the negative side.

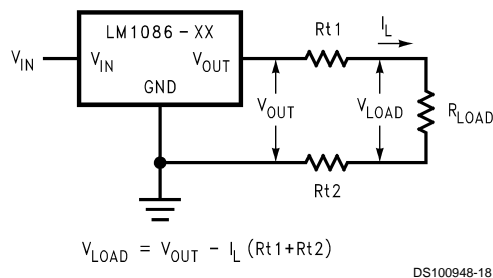

FIGURE 3. Typical Application using Fixed Output Regulator

When the adjustable regulator is used (*Figure 4*), the best performance is obtained with the positive side of the resistor $R1$ tied directly to the output terminal of the regulator rather

than near the load. This eliminates line drops from appearing effectively in series with the reference and degrading regulation. For example, a 5V regulator with 0.05 Ω resistance between the regulator and load will have a load regulation due to line resistance of 0.05 Ω \times I_L . If $R1$ (=125 Ω) is connected near the load the effective line resistance will be 0.05 Ω $(1 + R2/R1)$ or in this case, it is 4 times worse. In addition, the ground side of the resistor $R2$ can be returned near the ground of the load to provide remote ground sensing and improve load regulation.

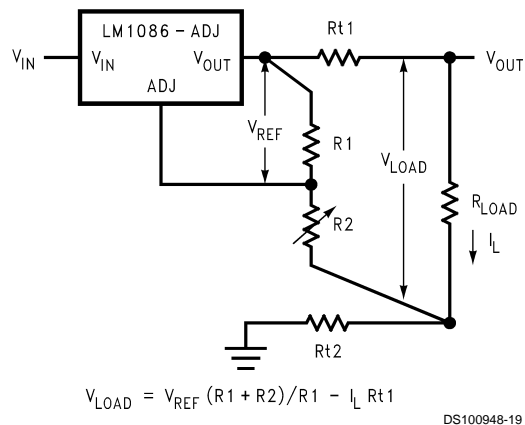

FIGURE 4. Best Load Regulation using Adjustable Output Regulator

3.0 Protection Diodes

Under normal operation, the LM1086 regulator does not need any protection diode. With the adjustable device, the internal resistance between the adjustment and output terminals limits the current. No diode is needed to divert the current around the regulator even with a capacitor on the adjustment terminal. The adjust pin can take a transient signal of $\pm 25V$ with respect to the output voltage without damaging the device.

When an output capacitor is connected to a regulator and the input is shorted, the output capacitor will discharge into the output of the regulator. The discharge current depends on the value of the capacitor, the output voltage of the regulator, and rate of decrease of V_{IN} . In the LM1086 regulator, the internal diode between the output and input pins can withstand microsecond surge currents of 10A to 20A. With an extremely large output capacitor ($\geq 1000 \mu F$), and with input instantaneously shorted to ground, the regulator could be damaged. In this case, an external diode is recommended between the output and input pins to protect the regulator, shown in *Figure 5*.

APPLICATION NOTE (Continued)

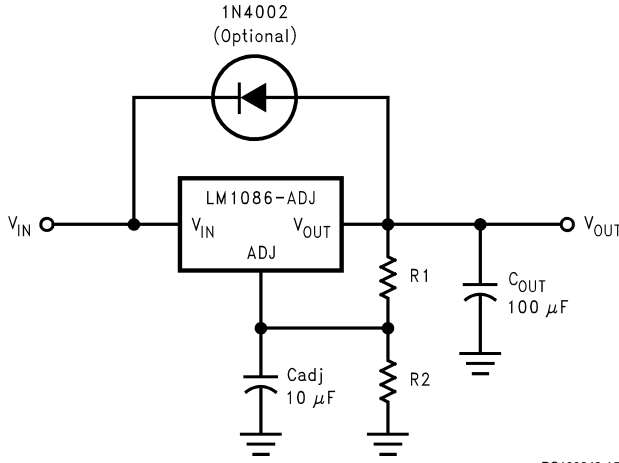

FIGURE 5. Regulator with Protection Diode

Overload Recovery

Overload recovery refers to regulator's ability to recover from a short circuited output. A key factor in the recovery process is the current limiting used to protect the output from drawing too much power. The current limiting circuit reduces the output current as the input to output differential increases. Refer to short circuit curve in the curve section.

During normal start-up, the input to output differential is small since the output follows the input. But, if the output is shorted, then the recovery involves a large input to output differential. Sometimes during this condition the current limiting circuit is slow in recovering. If the limited current is too low to develop a voltage at the output, the voltage will stabilize at a lower level. Under these conditions it may be necessary to recycle the power of the regulator in order to get the smaller differential voltage and thus adequate start up conditions. Refer to curve section for the short circuit current vs. input differential voltage.

Thermal Considerations

ICs heats up when in operation, and power consumption is one factor in how hot it gets. The other factor is how well the heat is dissipated. Heat dissipation is predictable by knowing the thermal resistance between the IC and ambient (θ_{JA}). Thermal resistance has units of temperature per power (C/W). The higher the thermal resistance, the hotter the IC.

The LM1086 specifies the thermal resistance for each package as junction to case (θ_{JC}). In order to get the total resistance to ambient (θ_{JA}), two other thermal resistance must be added, one for case to heat-sink (θ_{CH}) and one for heatsink to ambient (θ_{HA}). The junction temperature can be predicted as follows:

$$T_J = T_A + P_D (\theta_{JC} + \theta_{CH} + \theta_{HA}) = T_A + P_D \theta_{JA}$$

T_J is junction temperature, T_A is ambient temperature, and P_D is the power consumption of the device. Device power consumption is calculated as follows:

$$I_{IN} = I_L + I_G$$

$$P_D = (V_{IN} - V_{OUT}) I_L + V_{IN} I_G$$

Figure 6 shows the voltages and currents which are present in the circuit.

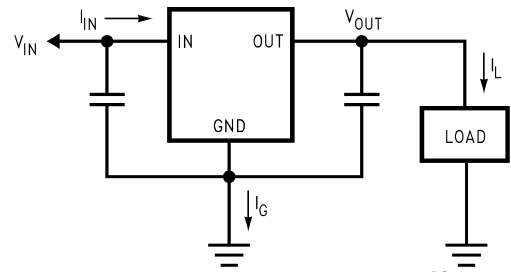

FIGURE 6. Power Dissipation Diagram

Once the device power is determined, the maximum allowable ($\theta_{JA(max)}$) is calculated as:

$$\theta_{JA(max)} = T_{R(max)} / P_D = T_{J(max)} - T_{A(max)} / P_D$$

The LM1086 has different temperature specifications for two different sections of the IC: the control section and the output section. The Electrical Characteristics table shows the junction to case thermal resistances for each of these sections, while the maximum junction temperatures ($T_{J(max)}$) for each section is listed in the Absolute Maximum section of the datasheet. $T_{J(max)}$ is 125°C for the control section, while $T_{J(max)}$ is 150°C for the output section.

$\theta_{JA(max)}$ should be calculated separately for each section as follows:

$$\theta_{JA(max, CONTROL SECTION)} = (125^\circ\text{C for } T_{A(max)}) / P_D$$

$$\theta_{JA(max, OUTPUT SECTION)} = (150^\circ\text{C for } T_{A(max)}) / P_D$$

The required heat sink is determined by calculating its required thermal resistance ($\theta_{HA(max)}$).

$$\theta_{HA(max)} = \theta_{JA(max)} - (\theta_{JC} + \theta_{CH})$$

$\theta_{HA(max)}$ should be calculated twice as follows:

$$\theta_{HA(max)} = \theta_{JA(max, CONTROL SECTION)} - (\theta_{JC} (CONTROL SECTION) + \theta_{CH})$$

$$\theta_{HA(max)} = \theta_{JA(max, OUTPUT SECTION)} - (\theta_{JC} (OUTPUT SECTION) + \theta_{CH})$$

If thermal compound is used, θ_{CH} can be estimated at 0.2 C/W. If the case is soldered to the heat sink, then a θ_{CH} can be estimated as 0 C/W.

After, $\theta_{HA(max)}$ is calculated for each section, choose the lower of the two $\theta_{HA(max)}$ values to determine the appropriate heat sink.

If PC board copper is going to be used as a heat sink, then Figure 7 can be used to determine the appropriate area (size) of copper foil required.

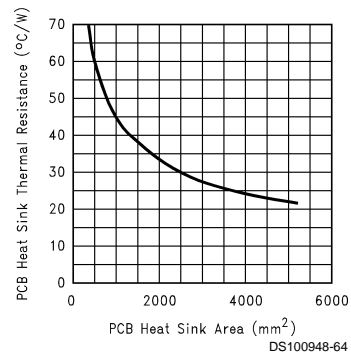
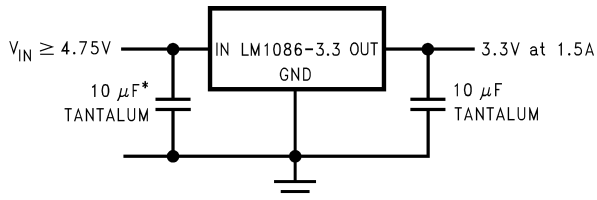

FIGURE 7. Heat sink thermal Resistance vs Area

Typical Applications



*MAY BE OMITTED IF INPUT SUPPLY IS WELL BYPASSED WITHIN 2" OF THE LM1086

DS100948-49

5V to 3.3V, 1.5A Regulator

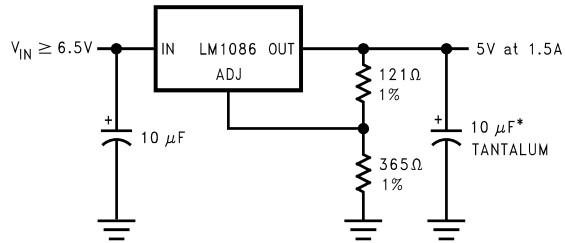

*REQUIRED FOR STABILITY

DS100948-50

Adjustable @ 5V

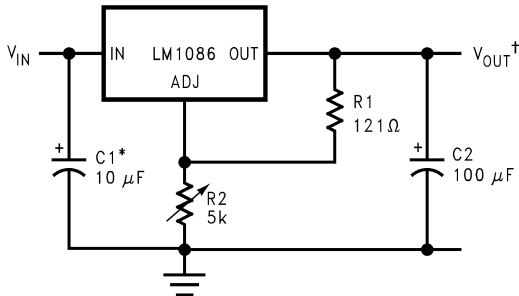

*NEEDED IF DEVICE IS FAR FROM FILTER CAPACITORS

$$V_{OUT}^{\dagger} = 1.25V \left(1 + \frac{R2}{R1}\right)$$

DS100948-52

1.2V to 15V Adjustable Regulator

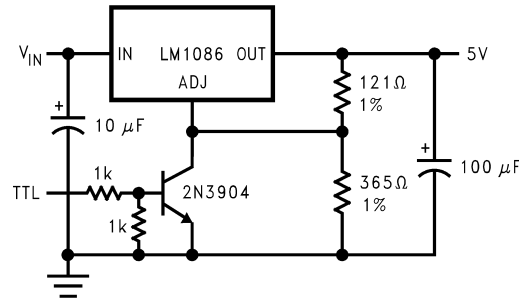

DS100948-53

5V Regulator with Shutdown

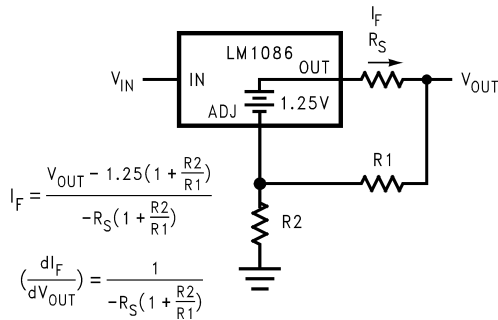

$$I_F = \frac{V_{OUT} - 1.25 \left(1 + \frac{R2}{R1}\right)}{-R_S \left(1 + \frac{R2}{R1}\right)}$$

$$\left(\frac{dI_F}{dV_{OUT}}\right) = \frac{1}{-R_S \left(1 + \frac{R2}{R1}\right)}$$

DS100948-54

Battery Charger

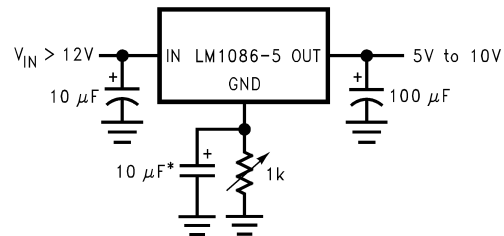

*OPTIONAL IMPROVES RIPPLE REJECTION

DS100948-55

Adjustable Fixed Regulator

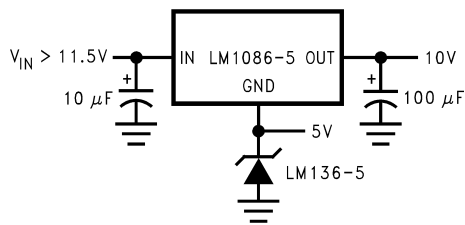

DS100948-56

Regulator with Reference

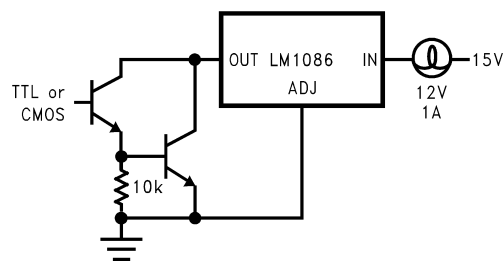

DS100948-57

High Current Lamp Driver Protection

Typical Applications (Continued)

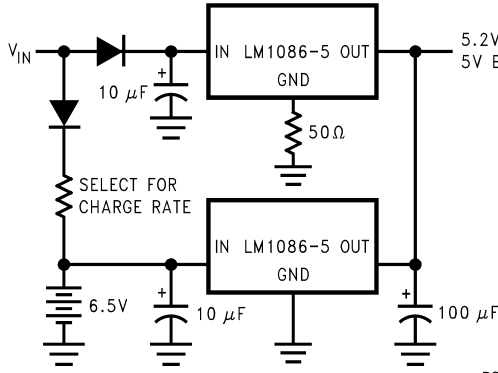

Battery Backup Regulated Supply

DS100948-59

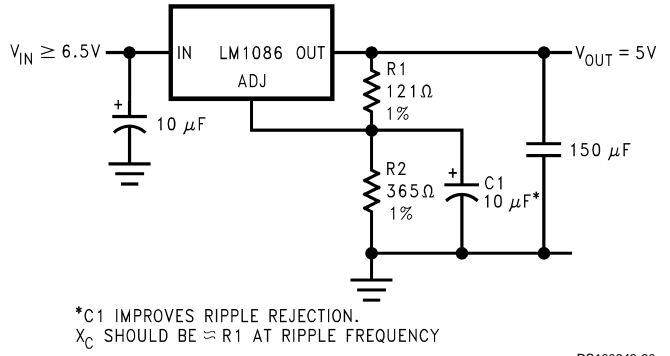

Ripple Rejection Enhancement

DS100948-60

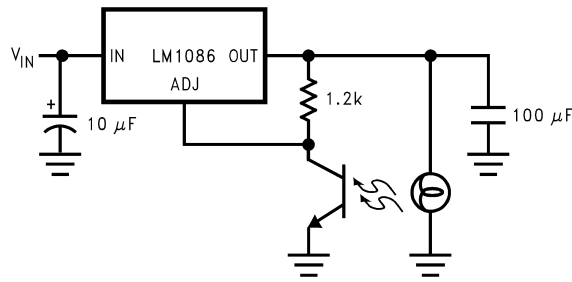

Automatic Light control

DS100948-61

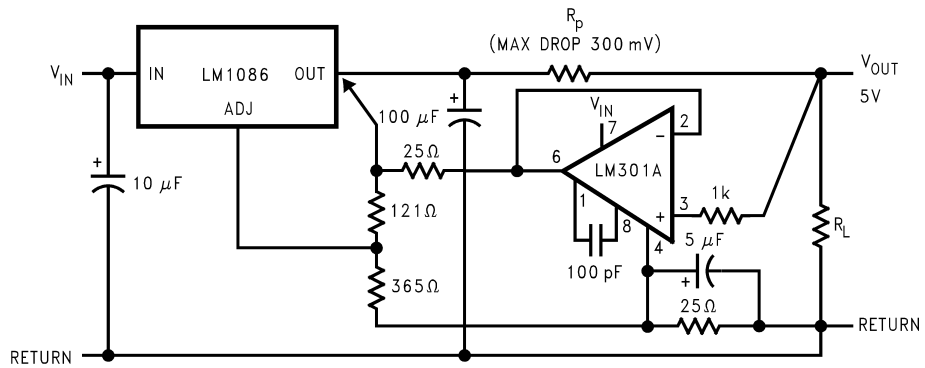

Remote Sensing

DS100948-58

Typical Applications (Continued)

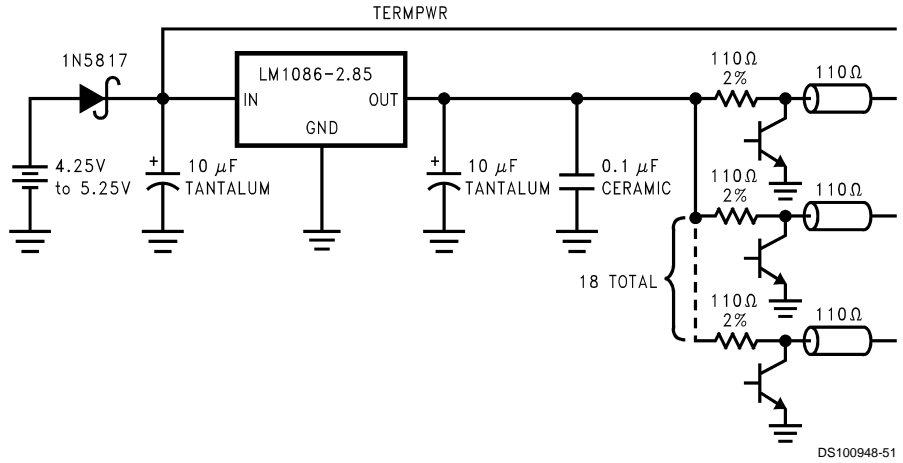

SCSI-2 Active termination

Physical Dimensions inches (millimeters) unless otherwise noted (Continued)

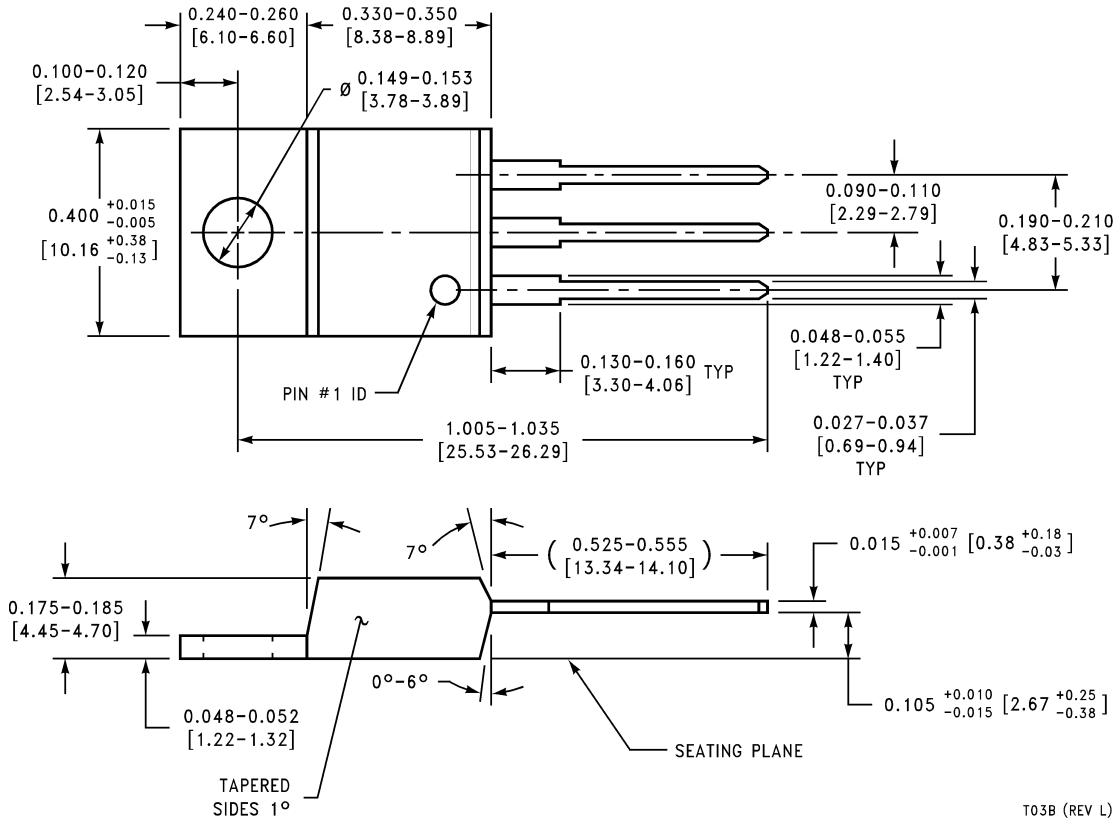

**3-Lead TO-220 Package
NSC Package Number T03B**

T03B (REV L)

LIFE SUPPORT POLICY

NATIONAL'S PRODUCTS ARE NOT AUTHORIZED FOR USE AS CRITICAL COMPONENTS IN LIFE SUPPORT DEVICES OR SYSTEMS WITHOUT THE EXPRESS WRITTEN APPROVAL OF THE PRESIDENT AND GENERAL COUNSEL OF NATIONAL SEMICONDUCTOR CORPORATION. As used herein:

1. Life support devices or systems are devices or systems which, (a) are intended for surgical implant into the body, or (b) support or sustain life, and whose failure to perform when properly used in accordance with instructions for use provided in the labeling, can be reasonably expected to result in a significant injury to the user.
2. A critical component is any component of a life support device or system whose failure to perform can be reasonably expected to cause the failure of the life support device or system, or to affect its safety or effectiveness.

 **National Semiconductor Corporation**
Americas
Tel: 1-800-272-9959
Fax: 1-800-737-7018
Email: support@nsc.com
www.national.com

National Semiconductor Europe
Fax: +49 (0) 180-530 85 86
Email: europe.support@nsc.com
Deutsch Tel: +49 (0) 69 9508 6208
English Tel: +44 (0) 870 24 0 2171
Français Tel: +33 (0) 1 41 91 8790

National Semiconductor Asia Pacific Customer Response Group
Tel: 65-2544466
Fax: 65-2504466
Email: ap.support@nsc.com

National Semiconductor Japan Ltd.
Tel: 81-3-5639-7560
Fax: 81-3-5639-7507