

GENERAL DESCRIPTION

The WT7510 provides protection circuits, power good output (PGO), fault protection latch (FPL_N), and a protection detector function (PDON_N) control. It can minimize external components of switching power supply systems in personal computer.

The Over Voltage Detector (OVD) monitors 3.3V, 5V, 12V input voltage level. The Under Voltage Detector (UVD) monitors 3.3V, 5V input voltage level. When OVD or UVD detect the fault voltage level, the FPL_N is latched HIGH and PGO go low. The latch can be reset by PDON_N go HIGH. There is 2.4 ms delay time for PDON_N turn off FPL_N.

When OVD and UVD detect the right voltage level, the power good output (PGO) will be issue.

FEATURES

- The Over Voltage Detector (OVD) monitors 3.3V, 5V, 12V input voltage level.
- The Under Voltage Detector (UVD) monitors 3.3V, 5V input voltage level.
- Both of the power good output (PGO) and fault protection latch (FPL_N) are Open Drain Output.
- 75 ms time delay for UVD.
- 300 ms time delay for PGO.
- 38 ms for PDON_N input signal De-bounce.
- 73 us for internal signal De-glitches.
- 2.4 ms time delay for PDON_N turn-off FPL_N.

PIN ASSIGNMENT AND PACKAGE TYPE

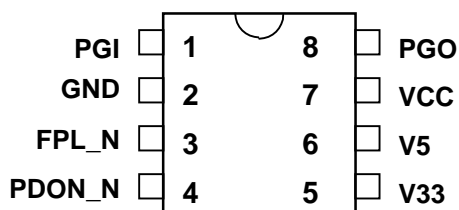

Package type	ORDERING INFORMATION
8-Pin Plastic DIP	WT7510-N080WT-12
8-Pin Plastic SOIC	WT7510-S080WT-12

PIN DESCRIPTION

Pin No.	Pin Name	TYPE	Description
1	PGI	I	power good input pin
2	GND	P	Ground
3	FPL_N	O	fault protection latch output pin(open drain output)
4	PDON_N	I	protection detector function ON/OFF control input pin
5	V33	I	3.3V input pin
6	V5	I	5V input pin
7	VCC	I	Supply voltage / 12V input pin
8	PGO	O	power good output pin(open drain output)

BLOCK DIAGRAM

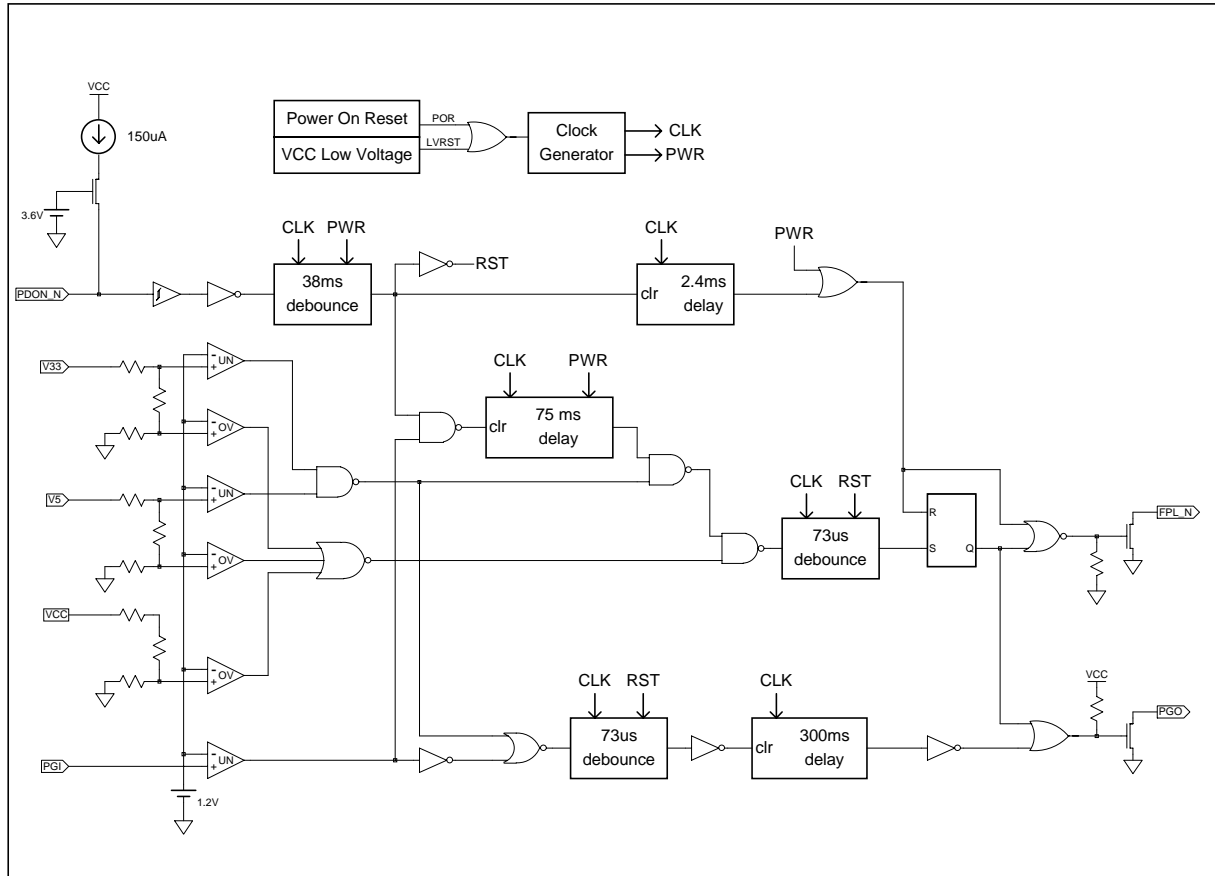

ABSOLUTE MAXIMUM RATINGS

Parameter		Conditions	Min.	Max.	Unit
Supply voltage, VCC			-0.3	16	V
Input voltage	PDON_N, V5, V33, PGI		-0.3	7	V
Output voltage	FPL_N		-0.3	16	V
	PGO		-0.3	7	V
Operating temperature			-40	125	°C
Storage temperature			-55	150	°C

*Note: Stresses above those listed may cause permanent damage to the devices

RECOMMENDED OPERATING CONDITIONS

Parameter		Conditions	Min.	Typ.	Max.	Unit
Supply voltage, VCC			3.8	12	15	V
Input voltage	PDON_N, V5, V33, PGI				7	V
Output voltage	FPL_N				15	V
	PGO				7	V
Output sink current	FPL_N				30	mA
	PGO				10	mA
Supply voltage rising time			1			ms

ELECTRICAL CHARACTERISTICS, at Ta=25°C and V_{CC}=5V.
Over Voltage Detection

Parameter		Condition	Min.	Typ.	Max.	Unit
Over voltage threshold	V33		3.7	3.9	4.1	V
	V5		5.7	6.1	6.5	V
	V _{CC} / V12		12.8	13.4	13.9	V
I _{LEAKAGE} Leakage current (FPL_N)	V(FPL_N) = 5V		5			uA
V _{OL} Low level output voltage (FPL_N)	I _{sink} 10mA			0.3		V
	I _{sink} 30mA			0.7		

PGI and PGO

Parameter		Condition	Min.	Typ.	Max.	Unit
Under voltage threshold	V33		2.55	2.69	2.83	V
	V5		4.1	4.3	4.47	V
Input threshold voltage(PGI)			1.16	1.20	1.24	V
I _{LEAKAGE} Leakage current(PGO)	PGO = 5V			5		uA
V _{OL} Low level output voltage(PGO)	I _{sink} 10mA			0.4		V

PDON_N

Parameter		Condition	Min.	Typ.	Max.	Unit
Input pull-up current		PDON_N= 0V		150		uA
High-level input voltage			2.4			V
Low-level input voltage					1.2	V

TOTAL DEVICE

Parameter		Condition	Min.	Typ.	Max.	Unit
I _{CC} Supply current		PDON_N= 5V			1	mA
V _{CC} low voltage				3		V

SWITCHING CHARACTERISTICS, V_{CC}=5V

Parameter		Condition	Min.	Typ.	Max.	Unit
t _{db1}	De-bounce time (PDON_N)		32	38	61	mS
t _{delay1}	Delay time (PGI to PGO)	Ta = -40°C ~ 125°C	200	300	490	mS
t _{db2}	De-bounce time (PDON_N)		32	38	61	mS
t _g	De-glitch time		63	73	120	uS
t _{delay2}	PDON_N to FPL_N delay time		t _{db2} +2.0	t _{db2} +2.4	t _{db2} +3.8	mS
t _{delay3}	Internal UVD delay time	FPL_N go low & every time PGI > 1.2V	65	75	122	mS

APPLICATION CIRCUIT

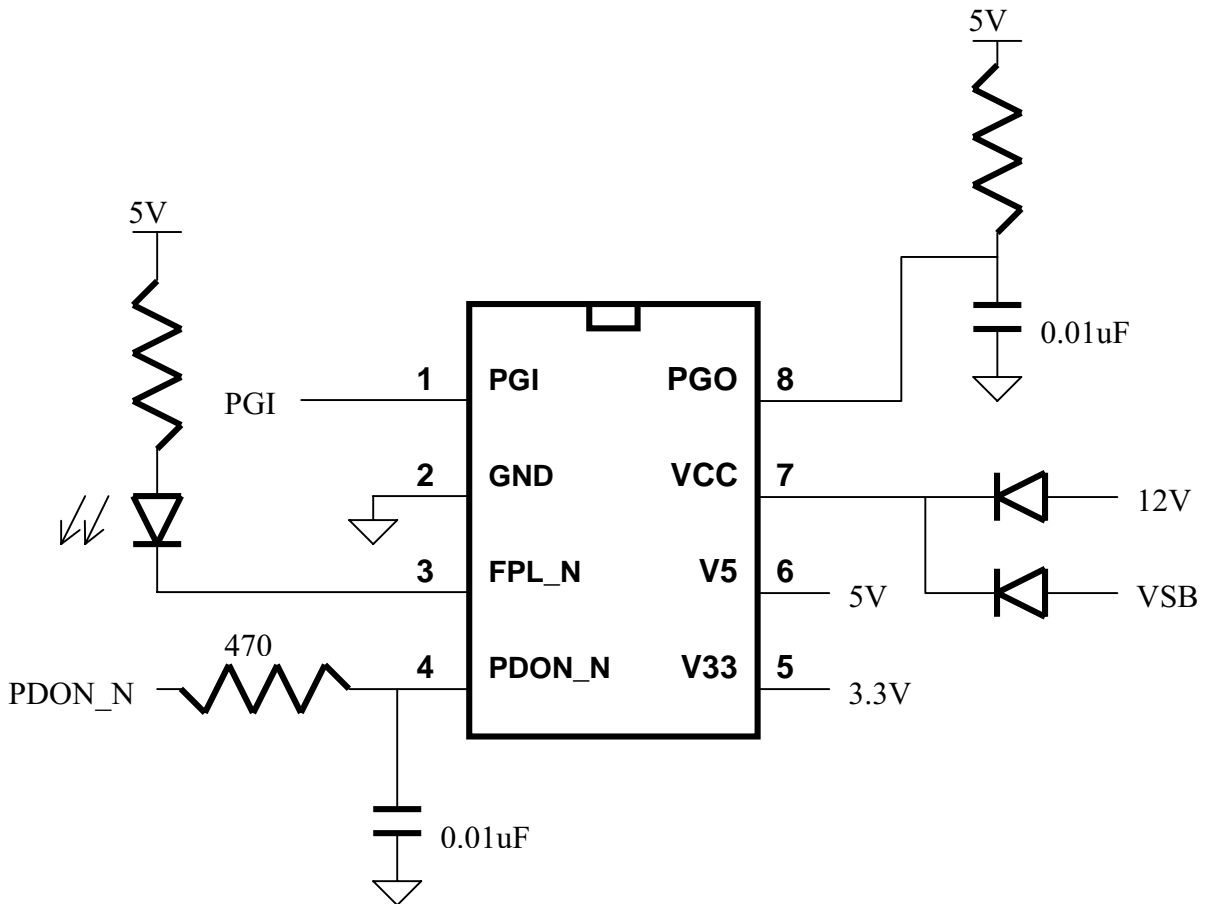

APPLICATION TIMMING

1.) PGI (UNDER_VOLTAGE) :

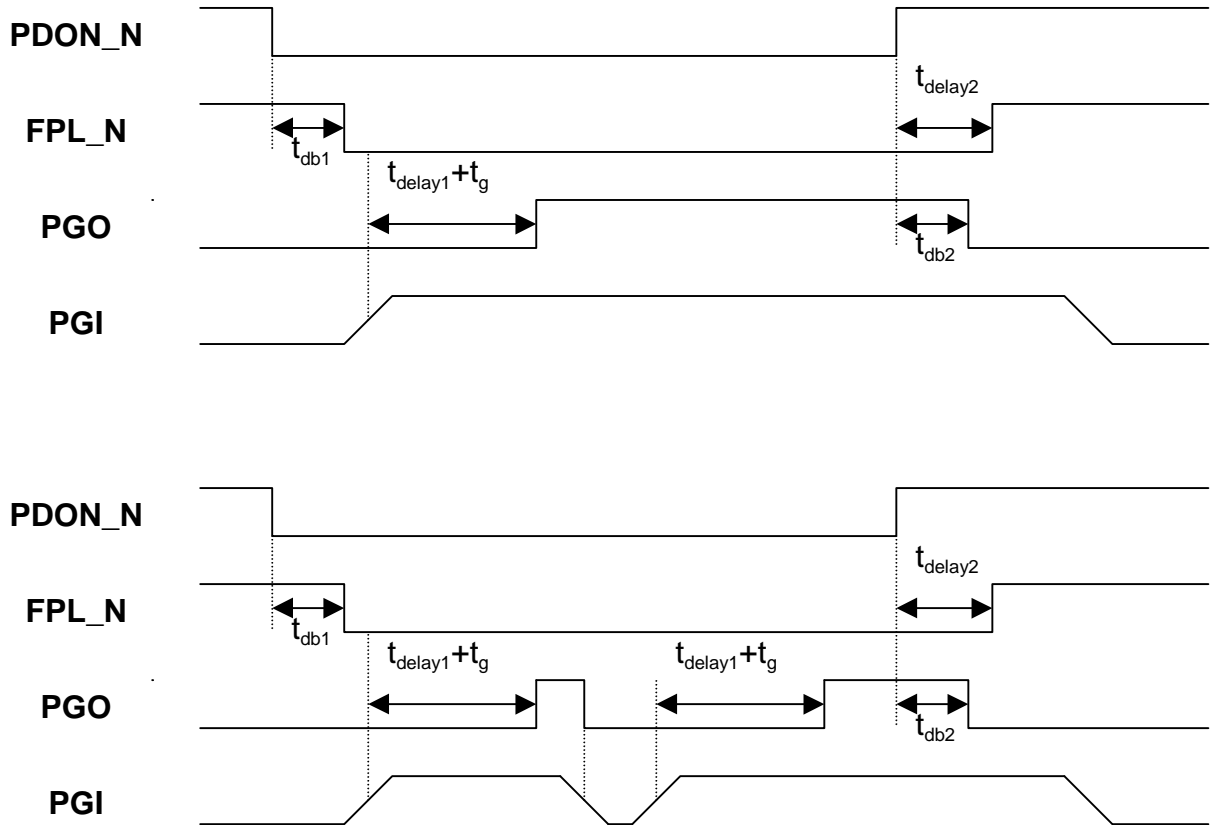

2.) V33, V5 (UNDER_VOLTAGE) :

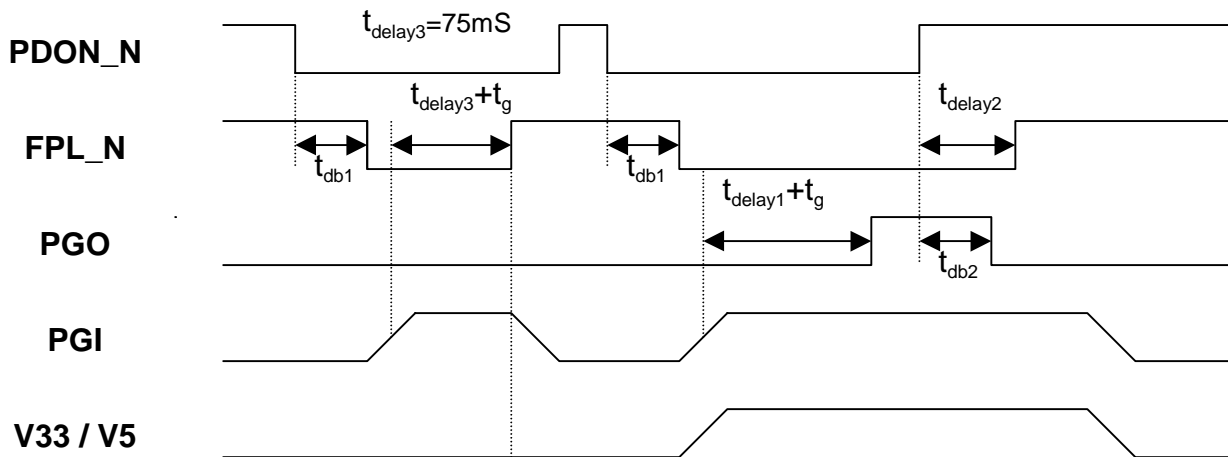
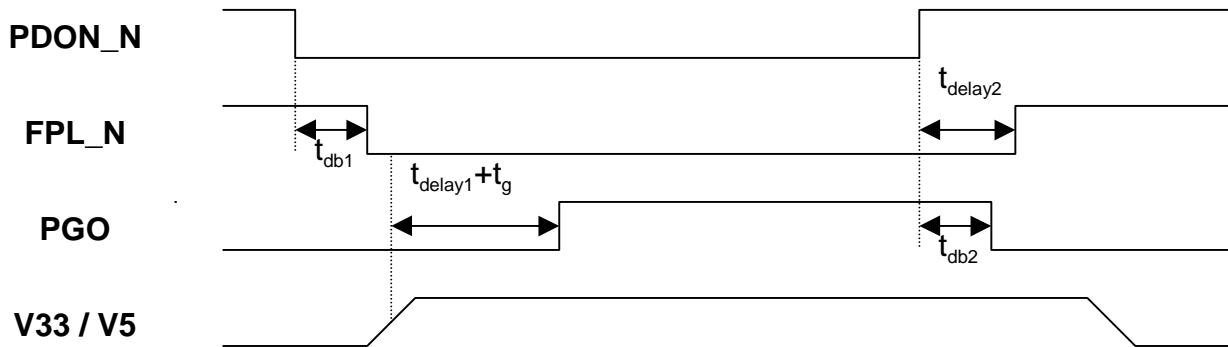

3.) V33, V5, V12 (OVER_VOLTAGE) :

