

# DC-DC Converter Control Circuits

## LR34063

### DESCRIPTION:

The LR34063 Series is a monolithic control circuit containing the primary functions required for DC-to-DC converters. These devices consist of an internal temperature compensated reference, comparator, controlled duty cycle oscillator with an active current limit circuit, driver and high current output switch. This series was specifically designed to be incorporated in Step-Down and Step-Up and Voltage-Inverting applications with a minimum number of external components.

### FEATURE:

- Operation from 3.0 V to 40 V Input
- Low Standby Current
- Current Limiting
- Output Switch Current to 1.5 A
- Output Voltage Adjustable
- Frequency Operation to 100 kHz
- Precision 2% Reference

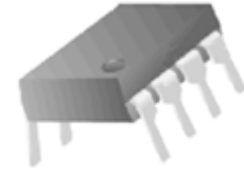

DIP-8



SOP-8

### ORDERING INFORMATION

Device	Package
LR34063	DIP-8
LR34063D	SOP-8

### BLOCK DIAGRAM

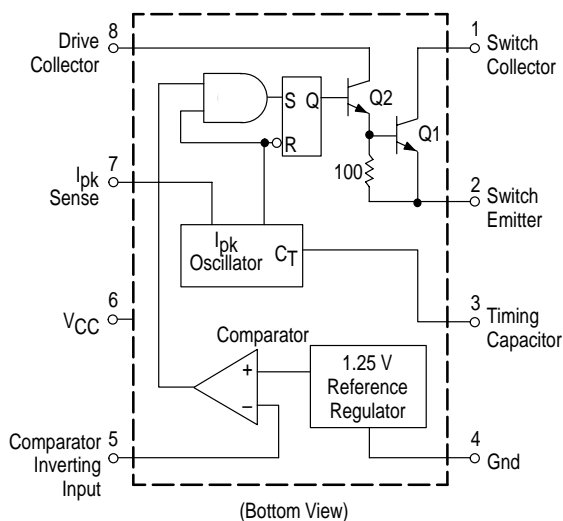

### PIN CONNECTIONS

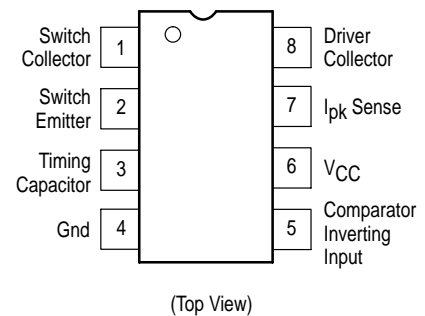

**LR34063**
**MAXIMUM RATINGS**

Rating	Symbol	Value	Unit
Power Supply Voltage	$V_{CC}$	40	Vdc
Comparator Input Voltage Range	$V_{IR}$	-0.3 to +40	Vdc
Switch Collector Voltage	$V_{C(\text{switch})}$	40	Vdc
Switch Emitter Voltage ( $V_{P_{in\ 1}} = 40\text{ V}$ )	$V_{E(\text{switch})}$	40	Vdc
Switch Collector to Emitter Voltage	$V_{CE(\text{switch})}$	40	Vdc
Driver Collector Voltage	$V_{C(\text{driver})}$	40	Vdc
Driver Collector Current (Note 1)	$I_{C(\text{driver})}$	100	mA
Switch Current	$I_{SW}$	1.5	A
Power Dissipation and Thermal Characteristics			
DIP-8 Package, $T_A = 25^\circ\text{C}$	$P_D$	1.25	W
Thermal Resistance	$R_{\theta JA}$	100	$^\circ\text{C/W}$
SOP-8 Package, D Suffix $T_A = 25^\circ\text{C}$	$P_D$	625	mW
Thermal Resistance	$R_{\theta JA}$	160	$^\circ\text{C/W}$
Operating Junction Temperature	$T_J$	+150	$^\circ\text{C}$
Operating Ambient Temperature Range	$T_A$	0 to +70	$^\circ\text{C}$
Storage Temperature Range	$T_{stg}$	-65 to +150	$^\circ\text{C}$

NOTES: 1. Maximum package power dissipation limits must be observed.

**ELECTRICAL CHARACTERISTICS** ( $V_{CC} = 5.0\text{ V}$ ,  $T_A = T_{low}$  to  $T_{high}$  [Note 2], unless otherwise specified.)

Characteristics	Symbol	Min	Typ	Max	Unit
-----------------	--------	-----	-----	-----	------

**OSCILLATOR**

Frequency ( $V_{P_{in\ 5}} = 0\text{ V}$ , $C_T = 1.0\text{ nF}$ , $T_A = 25^\circ\text{C}$ )	$f_{osc}$	24	33	42	kHz
Charge Current ( $V_{CC} = 5.0\text{ V}$ to $40\text{ V}$ , $T_A = 25^\circ\text{C}$ )	$I_{chg}$	24	35	42	$\mu\text{A}$
Discharge Current ( $V_{CC} = 5.0\text{ V}$ to $40\text{ V}$ , $T_A = 25^\circ\text{C}$ )	$I_{dischg}$	140	220	260	$\mu\text{A}$
Discharge to Charge Current Ratio (Pin 7 to $V_{CC}$ , $T_A = 25^\circ\text{C}$ )	$I_{dischg}/I_{chg}$	5.2	6.5	7.5	-
Current Limit Sense Voltage ( $I_{chg} = I_{dischg}$ , $T_A = 25^\circ\text{C}$ )	$V_{ipk(\text{sense})}$	250	300	350	mV

**OUTPUT SWITCH** (Note 3)

Saturation Voltage, Darlington Connection (Note 4) ( $I_{SW} = 1.0\text{ A}$ , Pins 1, 8 connected)	$V_{CE(\text{sat})}$	-	1.0	1.3	V
Saturation Voltage, Darlington Connection ( $I_{SW} = 1.0\text{ A}$ , $R_{P_{in\ 8}} = 82\ \Omega$ to $V_{CC}$ , Forced $\beta \approx 20$ )	$V_{CE(\text{sat})}$	-	0.45	0.7	V
DC Current Gain ( $I_{SW} = 1.0\text{ A}$ , $V_{CE} = 5.0\text{ V}$ , $T_A = 25^\circ\text{C}$ )	$h_{FE}$	50	75	-	-
Collector Off-State Current ( $V_{CE} = 40\text{ V}$ )	$I_{C(\text{off})}$	-	0.01	100	$\mu\text{A}$

NOTES: 2.  $T_{low} = 0^\circ\text{C}$ ,  $T_{high} = +70^\circ\text{C}$

3. Low duty cycle pulse techniques are used during test to maintain junction temperature as close to ambient temperature as possible.

4. If the output switch is driven into hard saturation (non-Darlington configuration) at low switch currents ( $\leq 300\text{ mA}$ ) and high driver currents ( $\geq 30\text{ mA}$ ), it may take up to  $2.0\ \mu\text{s}$  for it to come out of saturation. This condition will shorten the off time at frequencies  $\geq 30\text{ kHz}$ , and is magnified at high temperatures. This condition does not occur with a Darlington configuration, since the output switch cannot saturate. If a non-Darlington configuration is used, the following output drive condition is recommended:

$$\text{Forced } \beta \text{ of output switch: } \frac{I_{C \text{ output}}}{I_{C \text{ driver}} - 7.0\text{ mA}} \geq 10$$

\*The  $100\ \Omega$  resistor in the emitter of the driver device requires about  $7.0\text{ mA}$  before the output switch conducts.

**LR34063**

**ELECTRICAL CHARACTERISTICS (continued)** ( $V_{CC} = 5.0\text{ V}$ ,  $T_A = T_{low}$  to  $T_{high}$  [Note 2], unless otherwise specified.)

Characteristics	Symbol	Min	Typ	Max	Unit
<b>COMPARATOR</b>					
Threshold Voltage $T_A = 25^\circ\text{C}$ $T_A = T_{low}$ to $T_{high}$	$V_{th}$	1.23 1.21	1.25 –	1.27 1.29	V
Threshold Voltage Line Regulation ( $V_{CC} = 3.0\text{ V}$ to $40\text{ V}$ )	Reg <sub>line</sub>	–	1.4	5.0	mV
Input Bias Current ( $V_{in} = 0\text{ V}$ )	$I_{IB}$	–	–20	–400	nA
<b>TOTAL DEVICE</b>					
Supply Current ( $V_{CC} = 5.0\text{ V}$ to $40\text{ V}$ , $C_T = 1.0\text{ nF}$ , Pin 7 = $V_{CC}$ , $V_{Pin\ 5} > V_{th}$ , Pin 2 = Gnd, remaining pins open)	$I_{CC}$	–	–	4.0	mA

**NOTES:** 2.  $T_{low} = 0^\circ\text{C}$ ,  $T_{high} = +70^\circ\text{C}$

3. Low duty cycle pulse techniques are used during test to maintain junction temperature as close to ambient temperature as possible.

4. If the output switch is driven into hard saturation (non-Darlington configuration) at low switch currents ( $\leq 300\text{ mA}$ ) and high driver currents ( $\geq 30\text{ mA}$ ), it may take up to  $2.0\ \mu\text{s}$  for it to come out of saturation. This condition will shorten the off time at frequencies  $\geq 30\text{ kHz}$ , and is magnified at high temperatures. This condition does not occur with a Darlington configuration, since the output switch cannot saturate. If a non-Darlington configuration is used, the following output drive condition is recommended:

$$\text{Forced } \beta \text{ of output switch : } \frac{I_{C\ \text{output}}}{I_{C\ \text{driver}} - 7.0\ \text{mA}^*} \geq 10$$

\*The  $100\ \Omega$  resistor in the emitter of the driver device requires about  $7.0\text{ mA}$  before the output switch conducts.

LR34063

Figure 1. Output Switch On-Off Time versus Oscillator Timing Capacitor

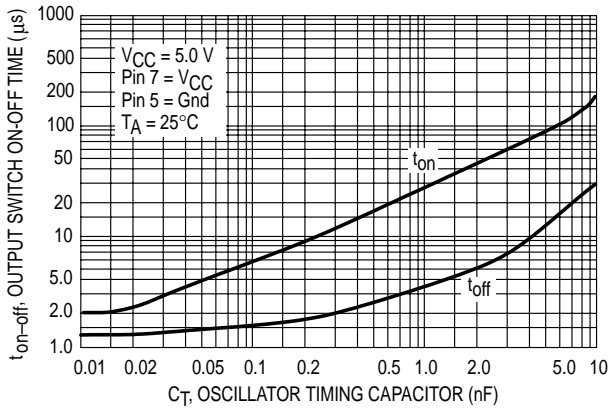

Figure 2. Timing Capacitor Waveform

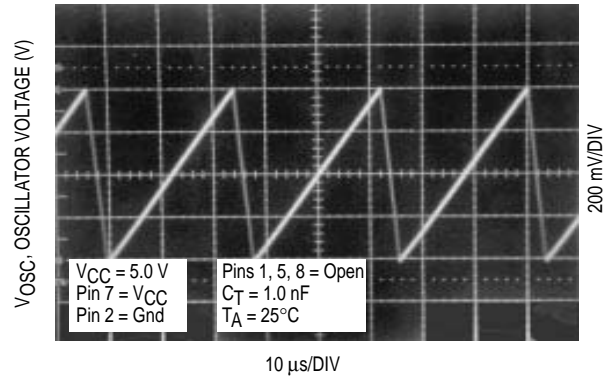

Figure 3. Emitter Follower Configuration Output Saturation Voltage versus Emitter Current

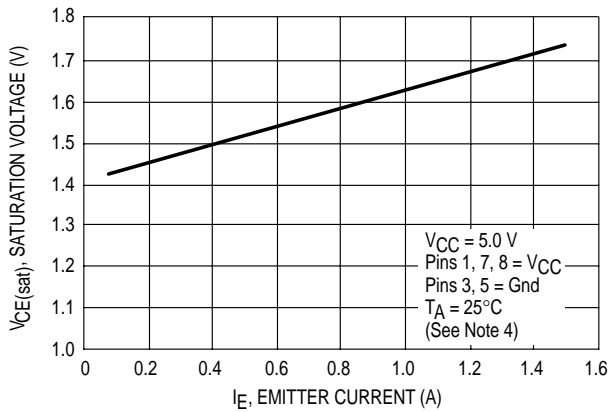

Figure 4. Common Emitter Configuration Output Switch Saturation Voltage versus Collector Current

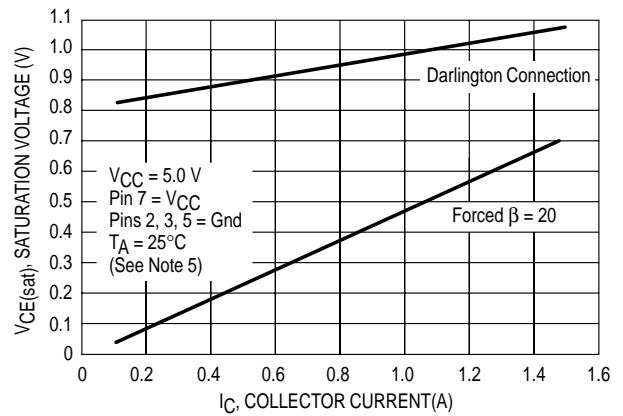

Figure 5. Current Limit Sense Voltage versus Temperature

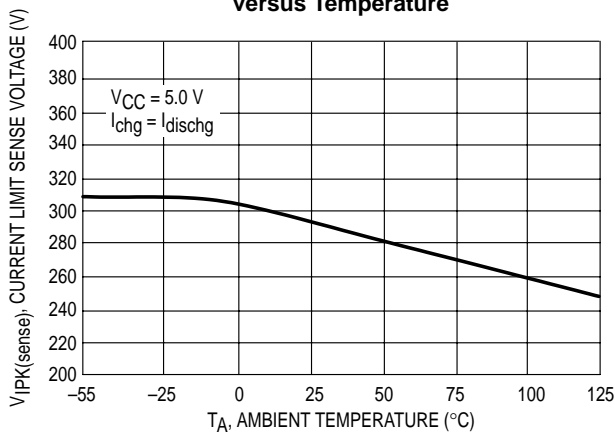
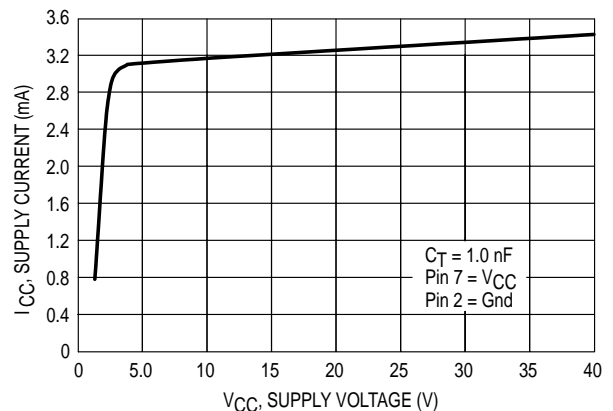
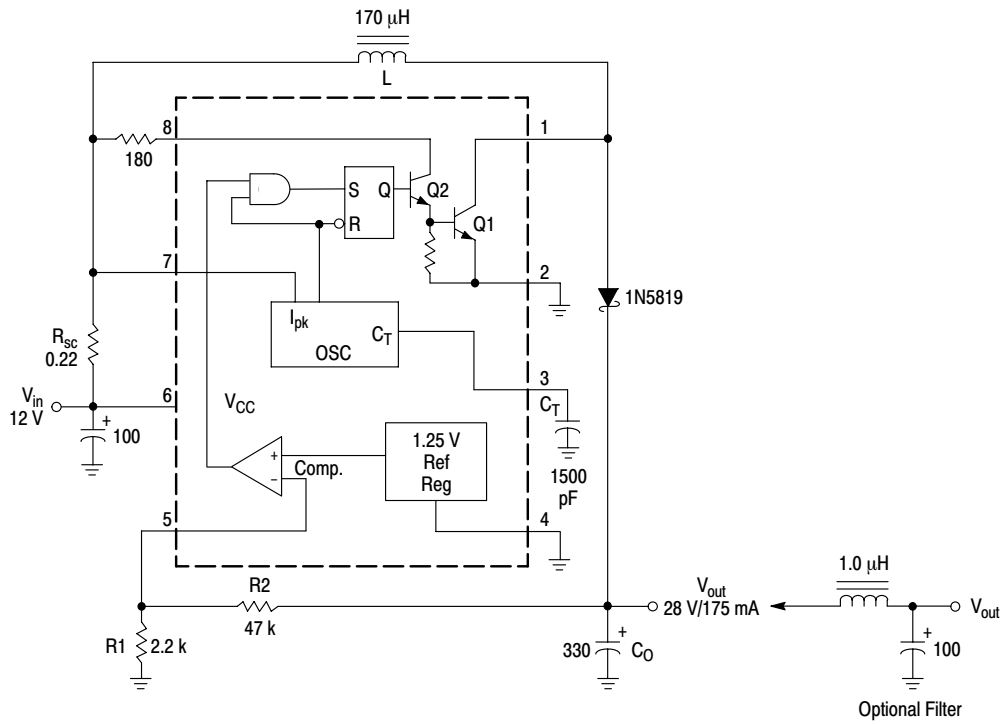

Figure 6. Standby Supply Current versus Supply Voltage



NOTE: 5. Low duty cycle pulse techniques are used during test to maintain junction temperature as close to ambient temperature as possible.



Test	Conditions	Results
Line Regulation	$V_{in} = 8.0\text{ V to }16\text{ V}, I_O = 175\text{ mA}$	$30\text{ mV} = \pm 0.05\%$
Load Regulation	$V_{in} = 12\text{ V}, I_O = 75\text{ mA to }175\text{ mA}$	$10\text{ mV} = \pm 0.017\%$
Output Ripple	$V_{in} = 12\text{ V}, I_O = 175\text{ mA}$	$400\text{ mVpp}$
Efficiency	$V_{in} = 12\text{ V}, I_O = 175\text{ mA}$	$87.7\%$
Output Ripple With Optional Filter	$V_{in} = 12\text{ V}, I_O = 175\text{ mA}$	$40\text{ mVpp}$

Figure 7. Step-Up Converter

LR34063

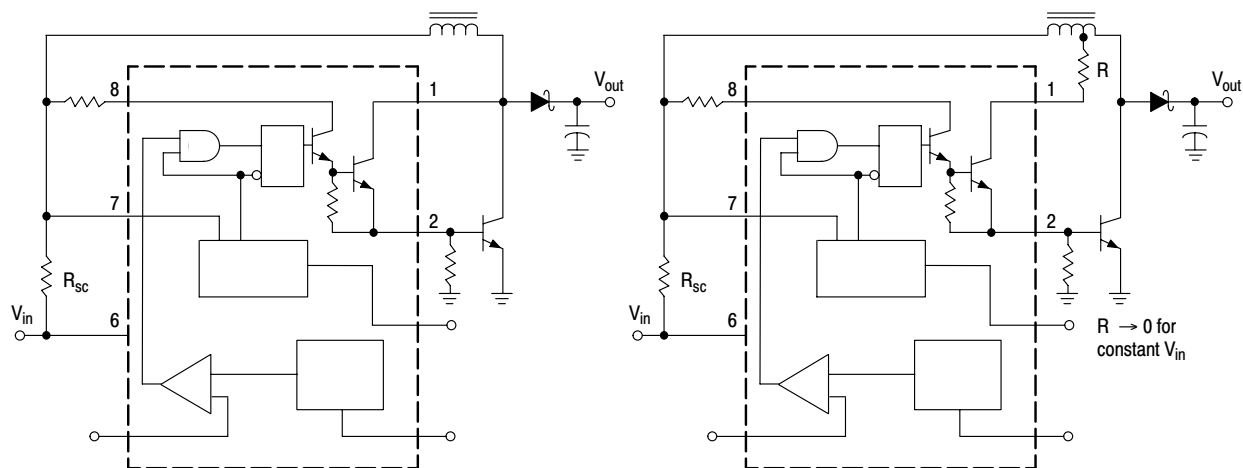

Figure 8. External Current Boost Connections for  $I_C$  Peak Greater than 1.5 A

8a. External NPN Switch

8b. External NPN Saturated Switch

(See Note 6)

6. If the output switch is driven into hard saturation (non-Darlington configuration) at low switch currents ( $\leq 300$  mA) and high driver currents ( $\geq 30$  mA), it may take up to  $2.0 \mu\text{s}$  to come out of saturation. This condition will shorten the off time at frequencies  $\geq 30$  kHz, and is magnified at high temperatures. This condition does not occur with a Darlington configuration, since the output switch cannot saturate. If a non-Darlington configuration is used, the following output drive condition is recommended.

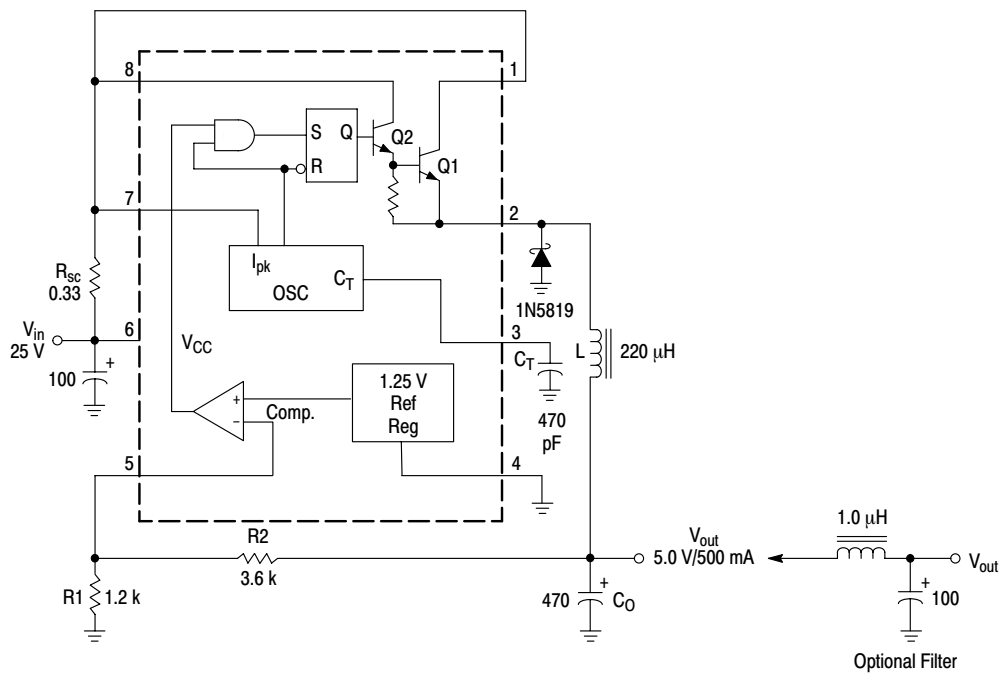

Test	Conditions	Results
Line Regulation	$V_{in} = 15\text{ V to }25\text{ V}, I_O = 500\text{ mA}$	$12\text{ mV} = \pm 0.12\%$
Load Regulation	$V_{in} = 25\text{ V}, I_O = 50\text{ mA to }500\text{ mA}$	$3.0\text{ mV} = \pm 0.03\%$
Output Ripple	$V_{in} = 25\text{ V}, I_O = 500\text{ mA}$	$120\text{ mVpp}$
Short Circuit Current	$V_{in} = 25\text{ V}, R_L = 0.1\ \Omega$	$1.1\text{ A}$
Efficiency	$V_{in} = 25\text{ V}, I_O = 500\text{ mA}$	$83.7\%$
Output Ripple With Optional Filter	$V_{in} = 25\text{ V}, I_O = 500\text{ mA}$	$40\text{ mVpp}$

Figure 9. Step-Down Converter

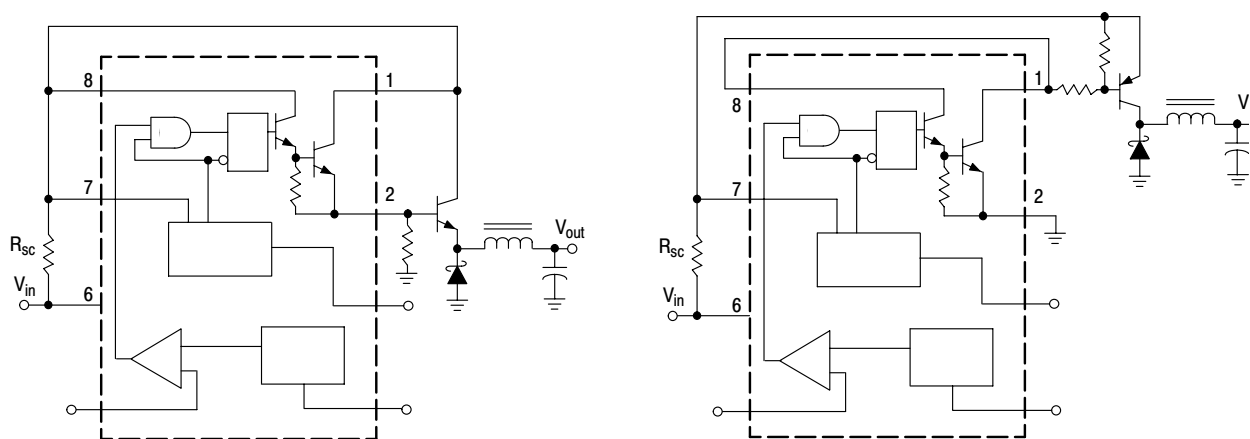
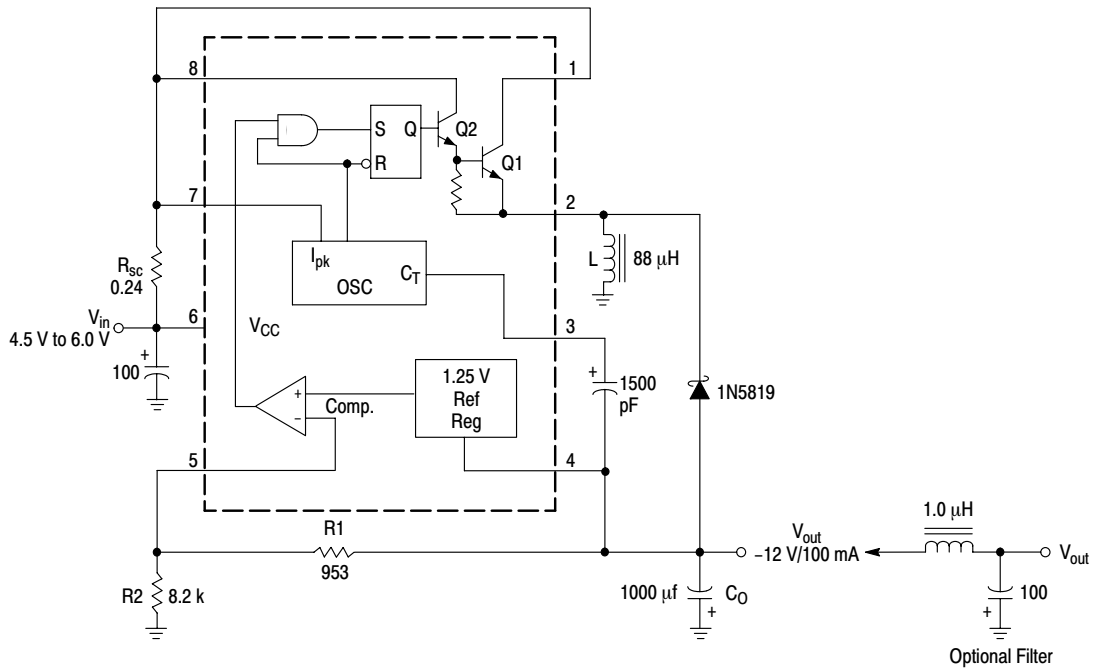

Figure 10. External Current Boost Connections for  $I_C$  Peak Greater than 1.5 A

10a. External NPN Switch

10b. External PNP Saturated Switch

LR34063



Test	Conditions	Results
Line Regulation	$V_{in} = 4.5 \text{ V to } 6.0 \text{ V}, I_O = 100 \text{ mA}$	$3.0 \text{ mV} = \pm 0.012\%$
Load Regulation	$V_{in} = 5.0 \text{ V}, I_O = 10 \text{ mA to } 100 \text{ mA}$	$0.022 \text{ V} = \pm 0.09\%$
Output Ripple	$V_{in} = 5.0 \text{ V}, I_O = 100 \text{ mA}$	$500 \text{ mVpp}$
Short Circuit Current	$V_{in} = 5.0 \text{ V}, R_L = 0.1 \Omega$	$910 \text{ mA}$
Efficiency	$V_{in} = 5.0 \text{ V}, I_O = 100 \text{ mA}$	$62.2\%$
Output Ripple With Optional Filter	$V_{in} = 5.0 \text{ V}, I_O = 100 \text{ mA}$	$70 \text{ mVpp}$

Figure 11. Voltage Inverting Converter

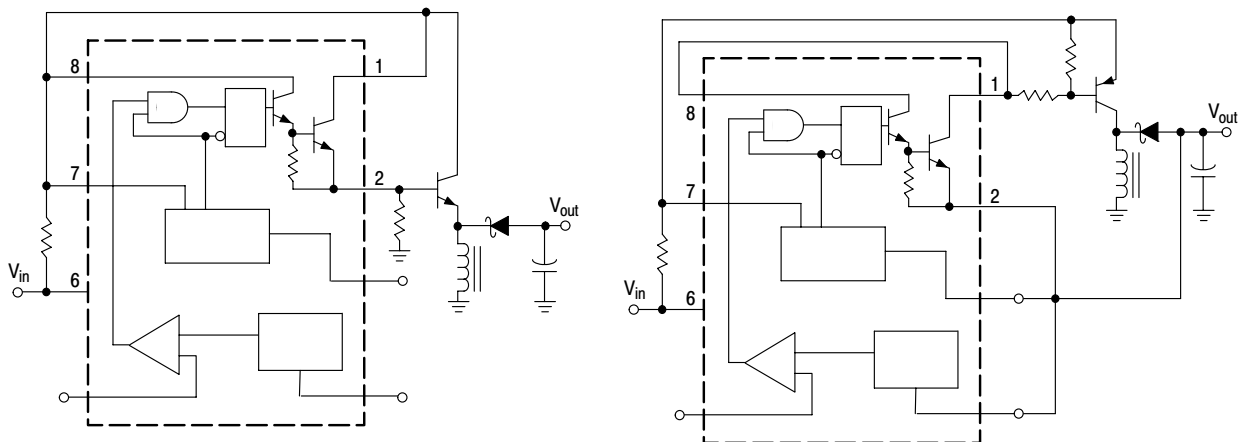

Figure 12. External Current Boost Connections for  $I_C$  Peak Greater than 1.5 A

12a. External NPN Switch

12b. External PNP Saturated Switch



LR34063

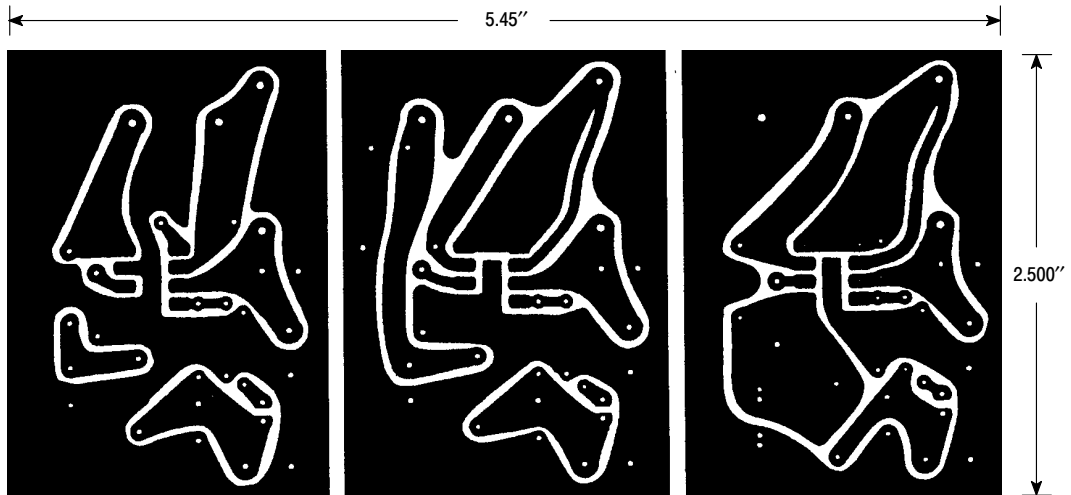

(Top view, copper foil as seen through the board from the component side)

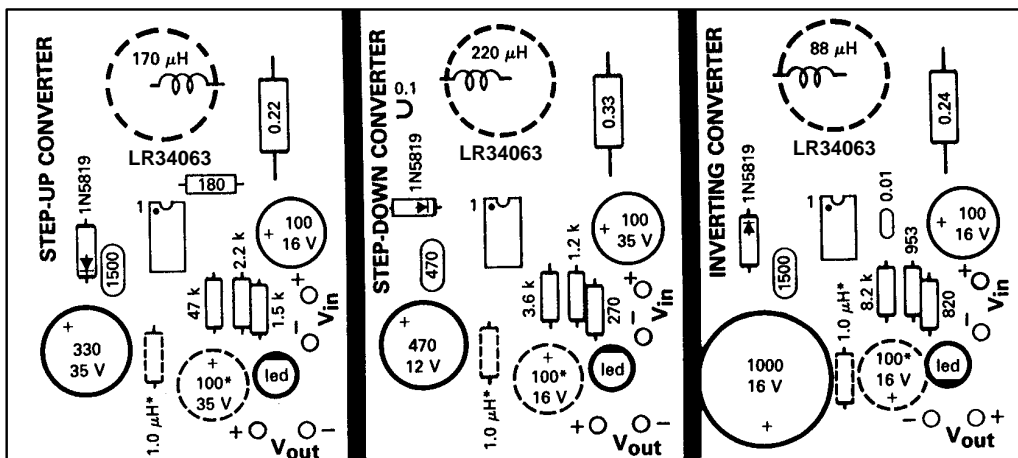

(Top View, Component Side)

\*Optional Filter.

Figure 13. Printed Circuit Board and Component Layout  
(Circuits of Figures 7, 9, 11)

INDUCTOR DATA

Converter	Inductance (μH)	Turns/Wire
Step-Up	170	38 Turns of #22 AWG
Step-Down	220	48 Turns of #22 AWG
Voltage-Inverting	88	28 Turns of #22 AWG

All inductors are wound on Magnetics Inc. 55117 toroidal core.

LR34063

Calculation	Step-Up	Step-Down	Voltage-Inverting
$t_{on}/t_{off}$	$\frac{V_{out} + V_F - V_{in(min)}}{V_{in(min)} - V_{sat}}$	$\frac{V_{out} + V_F}{V_{in(min)} - V_{sat} - V_{out}}$	$\frac{ V_{out}  + V_F}{V_{in} - V_{sat}}$
$(t_{on} + t_{off})$	$\frac{1}{f}$	$\frac{1}{f}$	$\frac{1}{f}$
$t_{off}$	$\frac{t_{on} + t_{off}}{\frac{t_{on}}{t_{off}} + 1}$	$\frac{t_{on} + t_{off}}{\frac{t_{on}}{t_{off}} + 1}$	$\frac{t_{on} + t_{off}}{\frac{t_{on}}{t_{off}} + 1}$
$t_{on}$	$(t_{on} + t_{off}) - t_{off}$	$(t_{on} + t_{off}) - t_{off}$	$(t_{on} + t_{off}) - t_{off}$
$C_T$	$4.0 \times 10^{-5} t_{on}$	$4.0 \times 10^{-5} t_{on}$	$4.0 \times 10^{-5} t_{on}$
$I_{pk(switch)}$	$2I_{out(max)} \left( \frac{t_{on}}{t_{off}} + 1 \right)$	$2I_{out(max)}$	$2I_{out(max)} \left( \frac{t_{on}}{t_{off}} + 1 \right)$
$R_{sc}$	$0.3/I_{pk(switch)}$	$0.3/I_{pk(switch)}$	$0.3/I_{pk(switch)}$
$L_{(min)}$	$\left( \frac{(V_{in(min)} - V_{sat})}{I_{pk(switch)}} \right) t_{on(max)}$	$\left( \frac{(V_{in(min)} - V_{sat} - V_{out})}{I_{pk(switch)}} \right) t_{on(max)}$	$\left( \frac{(V_{in(min)} - V_{sat})}{I_{pk(switch)}} \right) t_{on(max)}$
$C_O$	$9 \frac{I_{out} t_{on}}{V_{ripple(pp)}}$	$\frac{I_{pk(switch)}(t_{on} + t_{off})}{8V_{ripple(pp)}}$	$9 \frac{I_{out} t_{on}}{V_{ripple(pp)}}$

$V_{sat}$  = Saturation voltage of the output switch.  
 $V_F$  = Forward voltage drop of the output rectifier.

**The following power supply characteristics must be chosen:**

$V_{in}$  – Nominal input voltage.

$V_{out}$  – Desired output voltage,  $|V_{out}| = 1.25 \left( 1 + \frac{R2}{R1} \right)$

$I_{out}$  – Desired output current.

$f_{min}$  – Minimum desired output switching frequency at the selected values of  $V_{in}$  and  $I_O$ .

$V_{ripple(pp)}$  – Desired peak-to-peak output ripple voltage. In practice, the calculated capacitor value will need to be increased due to its equivalent series resistance and board layout. The ripple voltage should be kept to a low value since it will directly affect the line and load regulation.

Figure 14. Design Formula Table

LR34063

Mechanical Dimensions

SOP-8

Unit: mm

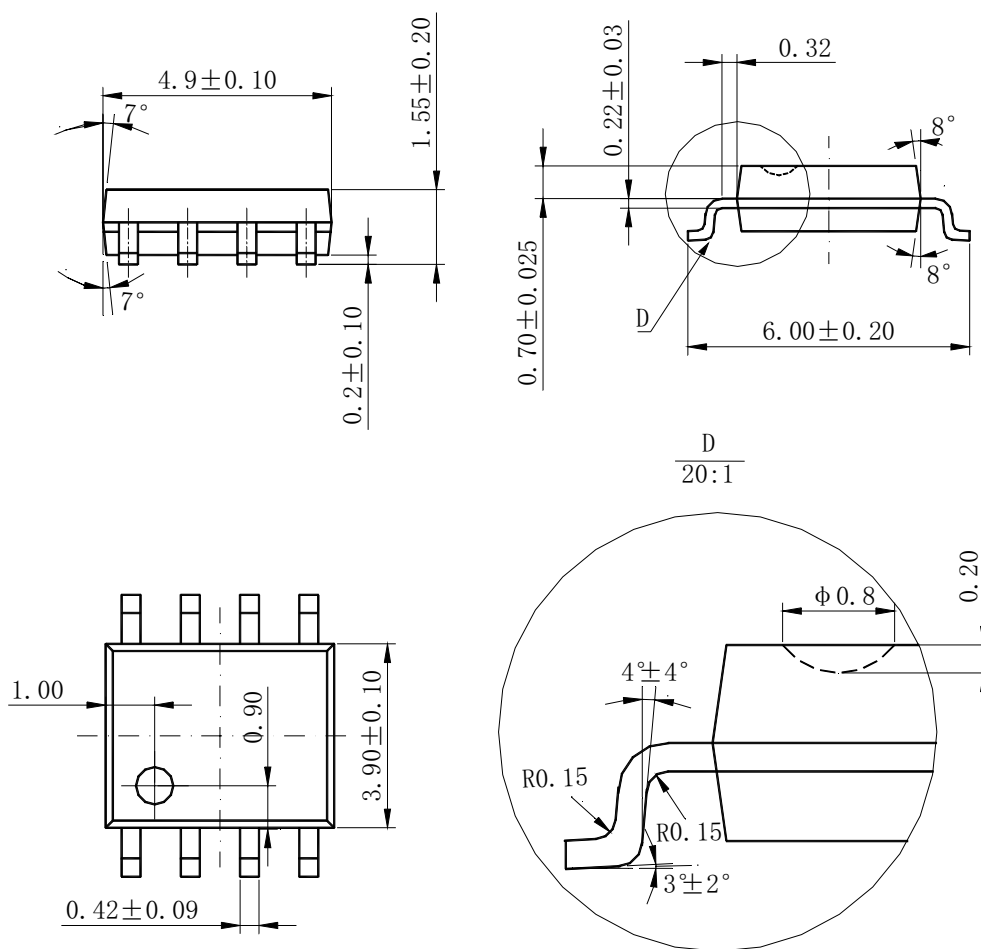

LR34063

Mechanical Dimensions (Continued)

DIP-8

Unit: mm

