

UL 746C

ISBN 1-55989-949-2

Polymeric Materials – Use in
Electrical Equipment
Evaluations

Underwriters Laboratories Inc. (UL)
333 Pfingsten Road
Northbrook, IL 60062-2096

UL Standard for Safety for Polymeric Material – Use in Electrical Equipment Evaluations, UL 746C

Fourth Edition, Dated December 27, 1995

Revisions: This Standard contains revisions through and including February 12, 2001.

These pages are being issued to correct omissions that occurred with the October 16, 2000 pages.

UL is in the process of converting its Standards for Safety to the Standard Generalized Markup Language (SGML), and implementing an SGML compliant document management and publishing system. SGML - an international standard (ISO 8879-1986) - is a descriptive markup language that describes a document's structure and purpose, rather than its physical appearance on a page. Significant benefits that will result from UL's use of SGML and these new systems include increased productivity, reduced turnaround times, and data and information consistency, reusability, shareability, and portability. However, the fonts, pagination, and general formatting of UL's new electronic publishing system differ from that of UL's previous publishing system. Consequently, when revision pages are issued for a Standard with the new publishing system, these differences may result in the printing of pages on which no requirements have been changed - these additional pages result from relocation of text due to repagination and reformatting of the Standard with the new publishing system.

Text that has been changed in any manner is marked with a vertical line in the margin. Changes in requirements are marked with a vertical line in the margin and are followed by an effective date note indicating the date of publication or the date on which the changed requirement becomes effective.

The following table lists the future effective dates with the corresponding item.

Future Effective Dates	References
June 1, 2004	3.3, 3.3.1, 3.21.1, 3.21.2, 3.34.1, 4.1, 4.2, 4.3, 8, 8.1.1, 8.1.2, 8.1.3, 8.1.4, 8.1.5, 8.1.6, 8.2, 8.2.1, 8.2.2, 9.1, 9.2, 9.3, 10.1, 14.3, and A.2. Table 4.1, Table 8.1, Table 8.2, Table 9.1, and Table A.1. Sections 5 and 6.

The revisions dated February 12, 2001 include a reprinted title page (page1) for this Standard.

As indicated on the title page (page 1), this UL Standard for Safety is an American National Standard. Attention is directed to the note on the title page of this Standard outlining the procedures to be followed to retain the approved text of this ANSI/UL Standard.

As indicated on the title page (page1), this UL Standard for Safety has been adopted by the Department of Defense.

The master for this Standard at UL's Northbrook Office is the official document insofar as it relates to a UL service and the compliance of a product with respect to the requirements for that product and service, or if there are questions regarding the accuracy of this Standard.

UL's Standards for Safety are copyrighted by UL. Neither a printed copy of a Standard, nor the distribution diskette for a Standard-on-Diskette and the file for the Standard on the distribution diskette should be altered in any way. All of UL's Standards and all copyrights, ownerships, and rights regarding those Standards shall remain the sole and exclusive property of UL.

All rights reserved. No part of this publication may be reproduced, stored in a retrieval system, or transmitted in any form by any means, electronic, mechanical photocopying, recording, or otherwise without prior permission of UL.

Revisions of UL Standards for Safety are issued from time to time. A UL Standard for Safety is current only if it incorporates the most recently adopted revisions.

UL provides this Standard "as is" without warranty of any kind, either expressed or implied, including but not limited to, the implied warranties of merchantability or fitness for any purpose.

In no event will UL be liable for any special, incidental, consequential, indirect or similar damages, including loss of profits, lost savings, loss of data, or any other damages arising out of the use of or the inability to use this Standard, even if UL or an authorized UL representative has been advised of the possibility of such damage. In no event shall UL's liability for any damage ever exceed the price paid for this Standard, regardless of the form of the claim.

UL will attempt to answer support requests concerning electronic versions of its Standards. However, this support service is offered on a reasonable efforts basis only, and UL may not be able to resolve every support request. UL supports the electronic versions of its Standards only if they are used under the conditions and operating systems for which it is intended. UL's support policies may change from time-to-time without notification.

UL reserves the right to change the format, presentation, file types and formats, delivery methods and formats, and the like of both its printed and electronic Standards without prior notice.

Purchasers of the electronic versions of UL's Standards for Safety agree to defend, indemnify, and hold UL harmless from and against any loss, expense, liability, damage, claim, or judgement (including reasonable attorney's fees) resulting from any error or deviation introduced while purchaser is storing an electronic Standard on the purchaser's computer system.

If a single-user version electronic Standard was purchased, one copy of this Standard may be stored on the hard disk of a single personal computer, or on a single LAN file-server or the permanent storage device of a multiple-user computer in such a manner that this Standard may only be accessed by one user at a time and for which there is no possibility of multiple concurrent access.

If a multiple-user version electronic Standard was purchased, one copy of the Standard may be stored on a single LAN file-server, or on the permanent storage device of a multiple-user computer, or on an Intranet server. The number of concurrent users shall not exceed the number of users authorized.

Electronic Standards are intended for on-line use, such as for viewing the requirements of a Standard, conducting a word search, and the like. Only one copy of the Standard may be printed from each single-user version of an electronic Standard. Only one copy of the Standard may be printed for each authorized user of a multiple-user version of an electronic Standard. Because of differences in the computer/software/printer setup used by UL and those of electronic Standards purchasers, the printed copy obtained by a purchaser may not look exactly like the on-line screen view or the printed Standard.

An employee of an organization purchasing a UL Standard can make a copy of the page or pages being viewed for their own fair and/or practical internal use.

The requirements in this Standard are now in effect, except for those paragraphs, sections, tables, figures, and/or other elements of the Standard having future effective dates as indicated in the note following the affected item. The prior text for requirements that have been revised and that have a future effective date are located after the Standard, and are preceded by a "SUPERSEDED REQUIREMENTS" notice.

New product submittals made prior to a specified future effective date will be judged under all of the requirements in this Standard including those requirements with a specified future effective date, unless the applicant specifically requests that the product be judged under the current requirements. However, if the applicant elects this option, it should be noted that compliance with all the requirements in this Standard will be required as a condition of continued Recognition, and Follow-Up Services after the effective date, and understanding of this should be signified in writing.

Copyright © 2001 Underwriters Laboratories Inc.

This Standard consists of pages dated as shown in the following checklist:

Page	Date
1	February 12, 2001
2-4	October 16, 2000
4A	February 12, 2001
4B-5	October 16, 2000
6	December 27, 1995
7	December 28, 1995
8	December 27, 1995
9	October 16, 2000
10	December 27, 1995
11-20	October 16, 2000
25-26	July 15, 1998
27-36	October 16, 2000
39	December 28, 1995
40	July 15, 1998
41	December 27, 1995
42-42B	July 15, 1998
43	October 16, 2000
44	December 27, 1995
45-46	December 28, 1995
47-49	December 27, 1995
50-51	October 16, 2000
52-58	December 27, 1995
59-61	July 7, 1999
62-64	December 27, 1995
65-66	October 16, 2000
66A	July 17, 1997
66B-67	March 19, 1997
68-69	December 27, 1995
70-71	May 20, 1996
72	December 27, 1995
73-74B	July 15, 1998
75	December 27, 1995
76-78	October 16, 2000
79-83	December 27, 1995
84	July 15, 1998
85	December 27, 1995
86-87	July 15, 1998
88	February 12, 2001
89-92	December 27, 1995
93-94B	February 12, 2001
95-104	December 27, 1995
105-114	October 16, 2000
A1-A4	October 16, 2000
SR1	February 12, 2001
SR2-SR13	October 16, 2000
SR14	February 12, 2001
SR15	October 16, 2000
SR16-SR19	February 12, 2001
SR20	October 16, 2000

DECEMBER 27, 1995
(Title Page Reprinted: February 12, 2001)

1

UL 746C

**Standard for Polymeric Materials – Use in Electrical Equipment
Evaluations**

The first edition was titled Test for Polymeric Enclosures of Portable Electrical Appliances and numbered UL 746.51.

First Edition – June, 1973
Second Edition – March, 1978
Third Edition – May, 1989

Fourth Edition

December 27, 1995

Approval as an American National Standard (ANSI) covers the numbered paragraphs on pages dated December 27, 1995. These pages should not be discarded when revised or additional pages are issued if it is desired to retain the ANSI approved text.

An effective date included as a note immediately following certain requirements is one established by Underwriters Laboratories Inc.

Approved as ANSI/UL 746C-1990, November 16, 1990
Approved as 746C-1995, June 12, 1995

The Department of Defense (DoD) has adopted UL 746C on November 3, 1988. The publication of revised pages or a new edition of this Standard will not invalidate the DoD adoption.

Revisions of this Standard will be made by issuing revised or additional pages bearing their date of issue. A UL Standard is current only if it incorporates the most recently adopted revisions, all of which are itemized on the transmittal notice that accompanies the latest set of revised requirements.

ISBN 1-55989-949-2

COPYRIGHT © 1973, 2001 UNDERWRITERS LABORATORIES INC.

No Text on This Page

CONTENTS

FOREWORD	6
-----------------------	---

INTRODUCTION

1 Scope	7
2 General	7
3 Glossary	9

ENCLOSURES

4 General	13
5 Portable Appliances	15
6 Fixed or Stationary Equipment	17
7 Alternate Enclosure Material Considerations	18

ELECTRICAL INSULATION

8 Material Property Considerations	18
8.1 General	18
8.2 Evaluation of Materials Not Meeting Preselection Test Performance Levels in Table 8.1	19
9 Internal Barriers	30

PERFORMANCE CRITERIA

10 General	31
------------------	----

ELECTRICAL

11 Comparative Tracking Index (CTI)	31
12 Dielectric Strength	32
13 High Current Arc Resistance to Ignition (HAI)	32
14 Hot-Wire Ignition (HWI) – Abnormal Overload Test or Glow-Wire End-Product Test	33
14.1 General	33
14.2 Abnormal overload test	33
14.3 Glow-wire end-product test (GWEPT)	34
15 Inclined Plane Tracking	34
16 Volume Resistivity	34

FLAMMABILITY

17 Flammability – 12 mm Flame	35
18 Flammability – 3/4-Inch Flame	35
19 Flammability – 127 mm (5 Inch) Flame	36
20 Enclosure Flammability – 746-5VS	39
20.1 Test criteria	39
21 Enclosure Flammability – Large Mass Considerations	39
22 Flame-Retardant Coatings	40
22.1 General	40
22.2 Test criteria	40

MECHANICAL

23	Crushing Resistance41
24	Resistance to Impact41

DIMENSIONAL CHANGE OF POLYMERIC PARTS

24A	Creep42
-----	-------------	-----

PERMANENCE

25	Permanence42B
25.1	General42B
25.2	Vicat softening point42B
25.3	Heat deflection temperature42B
25.4	Ball pressure temperature42B
26	Ultraviolet Light Exposure42B
27	Water Exposure and Immersion44
27.1	General44
27.2	Dimensional change44

SPECIAL END-USE CONSIDERATIONS

28	Abnormal Operation45
29	Severe Conditions45

THERMAL

30	Mold Stress-Relief Distortion45
31	Input to Motor46
32	Strain-Relief Test after Mold Stress-Relief Distortion46
33	Temperature Considerations– General46
34	Functional-Use Temperature Indices48
35	Generic Thermal Indices49
36	Relative Thermal Index52
37	Relative Thermal Capability52
38	Relative Thermal Capability (Alternate)54
39	Temperature Excursions Beyond the Maximum Use Temperature57

SPECIALIZED APPLICATIONS

40	General – Adhesives58
41	Function Analysis58
42	Program of Investigation58
42.1	End-product evaluation58
42.2	Effect of environmental conditions58
43	Coil Forms58
44	Conformal Coatings59

METALLIZED PARTS

45 General	59
46 Ductile Coatings	60
47 Brittle Coatings	60

TEST PERFORMANCE

48 General	61
48.1 Details	61
48.2 Voltmeters	61
48.3 Cheesecloth indicators	61
48.4 Supply-circuit voltage and frequency	61
49 End-Product Arc Resistance Test	62
50 Abnormal Overload Test	62
51 Flammability – 12 mm Flame Test	65
52 Flammability – 3/4 Inch Flame Test	66
53 Flammability – 5 Inch Flame Test	67
54 Enclosure Flammability – 746-5VS Test	68
54.1 Apparatus	68
54.2 Plaque conditioning	69
55 Flame-Retardant Coatings Test	70
55.1 Specimen conditioning	70
56 Crushing Resistance Test	72
57 Resistance to Impact Test	74
58 Ultraviolet Light Exposure Test	77
58.1 Apparatus	77
58.2 Method	77
59 Water Exposure and Immersion Test	84
60 Abnormal Operation Test	84
61 Severe Conditions Test	85
62 Mold Stress-Relief Distortion Test	85
62A Ball Pressure Test on End-Product	86
63 Input to Motors Test	86
64 Relative Thermal Capability	86
65 Relative Thermal Capability (Alternate)	87
66 Temperature Excursions Beyond the Maximum Use Temperature	88
67 Temperature Considerations – Illustrative Example	90
68 Temperature Considerations – Illustrative Example (Alternate RTC)	92
69 Adhesives – Specialized Applications	94A
69.1 General	94A
69.2 As-received test	95
69.3 Effect of temperature	95
69.4 Effect of humidity	97
69.5 Effect of cold	97
69.6 Effect of cyclic conditions	97
69.7 Other test considerations	98

COIL FORMS

70 Conformal Coating Test	98
70.1 General	98
70.2 Sample conditioning	102
71 Metallized Parts – Performance Considerations	105
71A Tape Adhesion Test	105
71A.1 General	105
71A.2 Samples	105
71A.3 Coating Thickness Measurement	106
71A.4 Sample Preparation	106
71A.5 Conditioning	106
71A.6 Results	107
72 Leakage Current Test	107
73 Glow-Wire End-Product Test	108
73.1 General	108
73.2 Significance	110
73.3 Apparatus	110
73.4 Specimens	111
73.5 Conditioning	111
73.6 Procedure	111

MARKING

74 General	112
------------------	-----

APPENDIX A Guidelines for Evaluation of Substitute Polymeric Materials

A Alternate Enclosure Material Considerations	A1
---	----

No Text on This Page

FOREWORD

A. This Standard contains basic requirements for products covered by Underwriters Laboratories Inc. (UL) under its Follow-Up Service for this category within the limitations given below and in the Scope section of this Standard. These requirements are based upon sound engineering principles, research, records of tests and field experience, and an appreciation of the problems of manufacture, installation, and use derived from consultation with and information obtained from manufacturers, users, inspection authorities, and others having specialized experience. They are subject to revision as further experience and investigation may show is necessary or desirable.

B. The observance of the requirements of this Standard by a manufacturer is one of the conditions of the continued coverage of the manufacturer's product.

C. A product which complies with the text of this Standard will not necessarily be judged to comply with the Standard if, when examined and tested, it is found to have other features which impair the level of safety contemplated by these requirements.

D. A product employing materials or having forms of construction which conflict with specific requirements of the Standard cannot be judged to comply with the Standard. A product employing materials or having forms of construction not addressed by this Standard may be examined and tested according to the intent of the requirements and, if found to meet the intent of this Standard, may be judged to comply with the Standard.

E. UL, in performing its functions in accordance with its objectives, does not assume or undertake to discharge any responsibility of the manufacturer or any other party. The opinions and findings of UL represent its professional judgment given with due consideration to the necessary limitations of practical operation and state of the art at the time the Standard is processed. UL shall not be responsible to anyone for the use of or reliance upon this Standard by anyone. UL shall not incur any obligation or liability for damages, including consequential damages, arising out of or in connection with the use, interpretation of, or reliance upon this Standard.

F. Many tests required by the Standards of UL are inherently hazardous and adequate safeguards for personnel and property shall be employed in conducting such tests.

INTRODUCTION

1 Scope

1.1 These requirements cover parts made of polymeric materials that are used in electrical equipment and describe the various test procedures and their use in the testing of such parts and equipment.

1.2 These requirements do not cover the specific insulating systems that are covered by the requirements contained in the Standard for Systems of Insulating Materials, General, UL 1446.

1.3 Test procedures are provided herein for the evaluation of polymeric materials in specific applications. These test procedures include references to data obtained from small-scale property tests conducted under standard conditions as well as other practical means of evaluation.

1.4 A product that contains features, characteristics, components, materials, or systems new or different from those covered by the requirements in this standard, and that involves a risk of fire or of electric shock or injury to persons shall be evaluated using appropriate additional component and end-product requirements to maintain the level of safety as originally anticipated by the intent of this standard. A product whose features, characteristics, components, materials, or systems conflict with specific requirements or provisions of this standard does not comply with this standard. Revision of requirements shall be proposed and adopted in conformance with the methods employed for development, revision, and implementation of this standard.

2 General

2.1 If a value for measurement is followed by a value in other units, the use of either value can be expected to provide equivalent results in the application of such requirements. Each of the requirements is stated in SI units as well as in U.S. customary units. Equivalent, although not necessarily exactly identical results, are to be expected from applying a requirement in SI units or U.S. customary units. Equipment calibrated in metric units is to be used when a requirement is applied in metric terms.

2.2 Any undated reference to a code or standard appearing in the requirements of this standard shall be interpreted as referring to the latest edition of that code or standard.

2.3 For reference purposes, Figure 2.1 describes the procedure to be followed in the evaluation of parts made of polymeric materials and covered by the requirements in this standard.

2.4 The requirements for tests for flammability of plastic materials for parts in devices and appliances, UL 94, covers flammability of polymeric materials used for parts in devices and appliances. The Standard for Polymeric Materials – Short Term Property Evaluations, UL 746A, contains short-term test procedures to be used for the evaluation of materials used for parts intended for specific applications in electrical end-products. The Standard for Polymeric Materials – Long Term Property Evaluations, UL 746B, contains long-term test procedures to be used for the evaluation of materials used for parts intended for specific applications in end-products. The Standard for Polymeric Materials – Fabricated Parts, UL 746D, contains requirements for traceability and performance of parts molded and fabricated from polymeric materials.

2.4 added April 12, 1995

2.5 Requirements for materials that have been modified to match the requirements of a specific application, including the use of recycled and regrind materials, the use of additives and colorants, and the blending of two or more materials, are described in the Standard for Polymeric Materials – Fabricated Parts, UL 746D.

2.5 added April 12, 1995

Figure 2.1
Flowchart of UL 746C procedures to evaluate polymeric parts

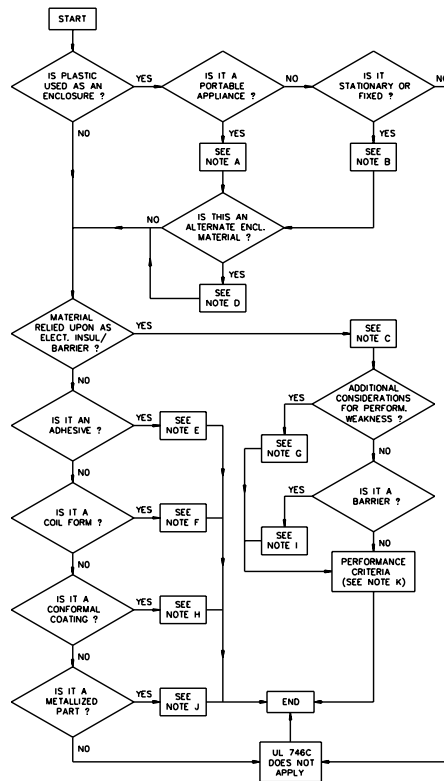

S3553

- A. Section 5
- B. Section 6
- C. Sections 8, 9, Table 8.1
- D. Section 7
- E. Sections 40 – 42, 69
- F. Section 43
- G. Table 8.2
- H. Sections 44, 70
- I. Table 9.1
- J. Sections 45 – 47, 71
- K. Sections 10 – 39

3 Glossary

3.1 For the purposes of this standard the following definitions apply:

3.2 ACCESSIBLE PART – A part so located that it can be contacted by a person, either directly or by means of a probe or a tool, or that is not recessed the required distance behind an opening.

3.3 ATTENDED INTERMITTENT-DUTY HOUSEHOLD APPLIANCE – *Deleted effective June 1, 2004*

3.3.1 ATTENDED EQUIPMENT– Equipment requiring a level of attendance where operator presence is normally required during use. Examples may include hand-held drills, electric knives, can openers, hand-held hair dryers, blenders, and vacuum cleaners.

Added 3.3.1 effective June 1, 2004

3.4 BRANCH CIRCUIT – A branch circuit is that portion of the building wiring system beyond the final overcurrent device on the power- distribution panel protecting the circuit to the field-wiring terminals of permanently connected equipment or to the receptacle outlet for cord-connected appliances.

3.5 COMPARATIVE TRACKING INDEX – Comparative tracking index (CTI) is determined by the method described in the Standard for Polymeric Materials – Short Term Property Evaluations, UL 746A, Recommended Method for Determining the Comparative Tracking Index of Solid Insulating Materials Under Moist Conditions.

CTI range – tracking index (Volts)	Assigned PLC
$600 \leq TI$	0
$400 \leq TI < 600$	1
$250 \leq TI < 400$	2
$175 \leq TI < 250$	3
$100 \leq TI < 175$	4
$0 \leq TI < 100$	5

3.6 CONFORMAL COATING – A protective covering applied on a printed wiring board to increase the dielectric voltage-withstand capability between conductors and to protect against environmental conditions.

3.7 CORD-CONNECTED UNIT – An appliance or product intended for connection to the branch-circuit power line by means of a power supply cord.

3.8 COUNTER-SUPPORTED APPLIANCE – An appliance that is physically supported by a counter, table or bench during the performance of its intended function.

3.9 DECORATIVE PART – A part used for ornamental purposes only and not as an enclosure or insulation of electrically live parts.

3.10 ENCLOSURE – That part of the product that:

- a) Renders inaccessible all or any parts of the equipment that may otherwise present a risk of electric shock and/or
- b) Retards propagation of flame initiated by electrical disturbances occurring within.

3.11 FIELD-WIRING TERMINAL – Any terminal where a power supply or other wire can be connected by an installer in the field.

3.12 FIXED EQUIPMENT – Any equipment or appliance that is intended to be permanently connected electrically to the wiring system.

3.13 FLAMMABILITY CLASSIFICATION – The flammability classification of a material is determined by tests described in the requirements for tests for flammability of plastic materials for parts in devices and appliances, UL 94.

3.13 revised February 3, 1997

3.14 GLOW WIRE RESISTANCE TO IGNITION – Glow wire resistance to ignition performance is expressed as the number of seconds required to ignite a specimen by an electrically heated bar operating at a specified temperature. This test is described in the Standard for Polymeric Materials – Short Term Property Evaluations, UL 746A.

3.15 GROUND – Earth ground, unless otherwise specified.

3.16 HAND-SUPPORTED APPLIANCE – An appliance that is physically supported by any part of the body of the user during the performance of its intended functions.

3.17 HIGH-CURRENT ARC RESISTANCE TO IGNITION – High-Current arc resistance to ignition (HAI) performance is expressed as the number of arc-rupture exposures (standardized as to electrode type and shape and electrical circuit) that are necessary to ignite a material when they are applied at a standard rate on the surface of the material. This test is described in the Standard for Polymeric Materials – Short Term Property Evaluation, UL 746A.

HAI range – mean number of arcs to cause ignition (NA)	Assigned PLC
$120 \leq NA$	0
$60 \leq NA < 120$	1
$30 \leq NA < 60$	2
$15 \leq NA < 30$	3
$0 \leq NA < 15$	4

3.18 HOT-WIRE RESISTANCE TO IGNITION – Hot-wire resistance to ignition (HWI) performance is expressed as the mean number of seconds needed to ignite standard specimens that are wrapped with resistance wire that dissipates a specified level of electrical energy. The test is described in the Standard for Polymeric Materials – Short Term Property Evaluations, UL 746A.

HWI range – mean ignition time (sec.)	Assigned PLC
$120 \leq IT <$	0
$60 \leq IT < 120$	1
$30 \leq IT < 60$	2
$15 \leq IT < 30$	3
$7 \leq IT < 15$	4
$0 \leq IT < 7$	5

3.19 HOUSEHOLD APPLIANCE – An appliance intended for use in the home.

3.20 INSULATED LIVE PART – An electrically live part that is provided with complete protection against electric shock and does not rely upon other parts for insulation.

3.21 INSULATION, FUNCTIONAL – The insulation necessary for the proper functioning of the product and for basic protection against electric shock.

3.21.1 INTERMITTENT OPERATION EQUIPMENT – Operation in a series of specified cycles each composed of a period of operation under NORMAL LOAD, followed by a rest period with the equipment switched off or running idle.

Added 3.21.1 effective June 1, 2004

3.21.2 LEVEL OF ATTENDANCE – The level of operator attendance is determined by whether or not operator presence is normally required or essential in order for the equipment to perform its intended task or purpose. Consideration should be given to whether the equipment has to be kept switched on by hand or foot, or equipment, which is continuously loaded by hand under normal use. The end-product standard should be referenced when determining the applicable level.

Added 3.21.2 effective June 1, 2004

3.22 LIVE PARTS – Denotes metal or other conductive parts that, during intended use, has an electrical potential difference with respect to earth ground or any other conductive part.

3.23 NON-HAZARDOUS ENERGY CIRCUIT – A circuit that is not considered to have a risk of electric shock or fire.

3.24 PERFORMANCE LEVEL CATEGORY – An integer that defines a range of test values for a given electrical/mechanical property test.

3.25 PORTABLE APPLIANCE – An appliance that is easily carried or conveyed by hand, and is provided with a power-supply cord for connection to the supply circuit.

3.26 POWER-SUPPLY CORD – The flexible electrically insulated cord provided to connect the product to the supply circuit.

3.27 PRIMARY CIRCUITS – The wiring and components that are conductively connected to the supply circuit.

3.28 PRINTED-WIRING BOARD – The finished combination of a pattern of conductive paths either on or within multilayer sheets of insulating material.

3.29 RISK OF ELECTRIC SHOCK – A risk of electric shock is considered to exist at any part if,

- a) The potential between the part and earth ground or any other accessible part is more than 42.4 V peak, and
- b) The continuous current flow through a 1500 ohm resistor connected across the potential exceeds 0.5 mA.

3.30 RISK OF FIRE – A risk of fire is considered to exist at any two points in a circuit where;

- a) The open circuit voltage is more than 42.4 V peak and the energy available to the circuit under any condition of load including short circuit, results in a current of 8 A or more after 1 minute of operation, or
- b) A power of more than 15 watts can be delivered into an external resistor connected between the two points.

3.30 revised February 3, 1997

3.31 SAME BASIC COMPOSITION – Materials that are of the identical generic material type having equivalent percentage and type of fillers, additives, resins and reinforcements.

3.32 SECONDARY CIRCUIT – A secondary circuit is a circuit supplied from a secondary winding of an isolating transformer.

3.33 STATIONARY EQUIPMENT – Any equipment or appliance that is intended to be fastened in place or located in a dedicated space, and is provided with a power-supply cord for connection to the supply circuit.

3.34 SUPPLY CIRCUIT – The branch circuit supplying electrical energy to the product.

3.34.1 UNATTENDED EQUIPMENT – Equipment where operator presence is likely, but absence is possible. Examples may include flatirons, and toasters. Equipment where operator presence is not required. Examples may include electric fry pans and coffee makers.

Added 3.34.1 effective June 1, 2004

3.35 UNINSULATED LIVE PART – A part involving the risks of fire or electric shock that is bare or has insulation that is not acceptable for the operating conditions (electrical potential, temperature, and the like) involved.

3.36 USER SERVICING – The replacing, cleaning, or adjusting done by the user.

3.37 VULCANIZED FIBER – A term used in this standard to denote a material normally used as electrical insulation. Vulcanized fiber is made by combining layers of chemically gelled paper. The zinc chloride used in gelling the paper is subsequently removed by a water leaching treatment, and the resultant product, after being dried and finished by calendering, is a dense material of partially regenerated cellulose where the fibrous structure is retained in varying degrees, depending upon the grade of fiber. Cellulose fiberboard, pressboard, fullerboard, or cardboard are not acceptable as the equivalent of fiber. Fishpaper is a designation commonly used in the trade to refer to thin sheets of electrical grade vulcanized fiber.

ENCLOSURES

4 General

4.1 Equipment having an enclosure, or parts of the enclosure, comprised of polymeric material shall comply with the applicable requirements in Table 4.1.

Revised 4.1 effective June 1, 2004

4.2 The requirements in this Section, do not cover the additional considerations that must be given to enclosure materials exposed to oils, acids, solvents, cleaning agents, and the like in use. The performance of the material shall not be adversely affected by such environments (if encountered in the end-use application) as determined by applicable tests as detailed in the Standard for Polymeric Materials – Short Term Property Evaluation, UL 746A.

Added 4.2 effective June 1, 2004

4.3 Polymeric material used to enclose a metal housing that encloses insulated or uninsulated live parts or as a decorative part, shall be classed either 5VA, 5VB, V-0, V-1, V-2, or HB by the burning tests described in the requirements for tests for flammability of plastic materials, UL 94, and comply with the Flame Spread requirements in Section 21 for large mass applications.

Exception No. 1: Decorative parts are not required to be made of a material classed 5VA, 5VB, V-0, V-1, V-2, or HB, providing the part: does not occupy a volume greater than 2 cubic centimeters (0.122 cubic inch), does not have any dimension greater than 3 cm (1.18 inch), and is located so it cannot propagate flame from one area to another or bridge between a possible source of ignition and other ignitable parts.

Exception No. 2: A material is to be considered equivalent if it complies with the requirements in 17.1, 51.1 – 51.5, 19.1, 53.1 – 53.5, when flame tested as used in the equipment. The use of a flame-retardant coating applied to the inside of a polymeric enclosure is not acceptable unless the coating/material interface is found to be acceptable by separate investigation (see Flame-Retardant Coatings, Section 22).

Added 4.3 effective June 1, 2004

Table 4.1
Enclosure Requirements

Added Table 4.1 effective June 1, 2004

Type of Equipment	Portable Attended Household Equipment	All other Portable Equipment	Stationary And Fixed
Type of Use			
Applicable requirements shown below			
Minimum Flammability Rating	HB^{a,d}	v^{b,d}	5VA^{c,d}
Material Properties per Table 8.1	Yes	Yes	Yes
Impact Test per Section 24	Yes	Yes	Yes
Crush Resistance per 23.1	No	No	Yes
Abnormal Operations Test per 28.1	Yes	Yes	Yes
Severe Conditions Test per 29.1	Yes ^j	No ^j	Yes
Mold-Stress Relief Distortion per Section 30.1	Yes ^e	Yes ^e	Yes ^e
Input after Mold-Stress Relief per 31.1	Yes	No	Yes
Strain Relief Test per 31.1	Yes ^f	Yes ^f	Yes ^f
UV Resistance per 26.1	Yes ^g	Yes ^g	Yes ^g

Table 4.1 Continued on Next Page

Table 4.1 Continued

Type of Equipment	Portable Attended Household Equipment	All other Portable Equipment	Stationary And Fixed
Type of Use			
Applicable requirements shown below			
Minimum Flammability Rating	HB ^{a,d}	v ^{b,d}	5VA ^{c,d}
Water Exposure and Immersion per Sec. 27	Yes ^h	Yes ^h	Yes ^h
Dimensional Stability per 27.2	Yes	Yes	Yes
Conduit Connections	No	No	Yes ⁱ
<p>^a HB or the enclosure complies with the 12 mm or 20 mm end-product flame tests as described in section 17 and 18 respectively.</p> <p>^b V=V-0, V-1 or V-2 classed materials, or the enclosure complies with the 12 mm or 20 mm end-product flame tests as described in section 17 and 18 respectively. Exception: Use of a HB enclosure material may be acceptable if determined by the applicable requirements in the end-product standard.</p> <p>^c 5VA or the enclosure complies with the 127 mm end-product flame tests as described in section 19.</p> <p>^d May require flame spread per section 21.</p> <p>^e Mold-Stress Relief for HB enclosures use section 62.2. For V, 5VA or enclosures that comply with the 12 mm or 20 mm end-product flame tests as described in section 17 and 18 respectively use section 62.1.</p> <p>^f This test is only required if the means relief is secured to the enclosure or is an integral part of the polymeric enclosure.</p> <p>^g This test is only required if the equipment is constructed such that exposure to outdoor weather conditions or UV radiation could increase the risk of fire, electrical shock, or injury to persons.</p> <p>^h This test is only required if the equipment is constructed such that exposure to water could increase the risk of fire, electrical shock, or injury to persons.</p> <p>ⁱ This test is required only if the equipment is permanently connected electrically to the wiring system. The continuity of the conduit system shall be a metal-to-metal contact. If the integrity of the polymeric enclosure is relied upon to provide for bonding between the parts of the conduit system at any location where conduit may be connected, the bonding shall be evaluated by the requirements contained in the Standard for Enclosures for Electrical Equipment, UL 50. If the polymeric enclosure is intended for connection to a rigid conduit system, it shall acceptably perform when tested using the pullout, torque and bending tests as described in the Standard for Industrial Control Equipment, UL 508.</p> <p>^j This test is only required for materials that are rated HB.</p>			

5 Portable Appliances

Section 5 deleted effective June 1, 2004. Applicable requirements for Portable Appliances moved to Section 4

5.1 *Deleted effective June 1, 2004*

5.2 *Deleted effective June 1, 2004*

5.3 *Deleted effective June 1, 2004*

5.4 *Deleted effective June 1, 2004*

5.5 *Deleted effective June 1, 2004*

5.6 *Deleted effective June 1, 2004*

Figure 5.1
Enclosure requirements for portable appliances

Figure 5.1 deleted effective June 1, 2004

5.7 Deleted effective June 1, 2004

5.8 Deleted effective June 1, 2004

5.9 Deleted effective June 1, 2004

5.10 Deleted effective June 1, 2004

5.11 Deleted effective June 1, 2004

6 Fixed or Stationary Equipment

Section 6 deleted effective June 1, 2004. Applicable requirements for Fixed or Stationary Equipment moved to Section 4

6.1 Deleted effective June 1, 2004

6.2 Deleted effective June 1, 2004

6.3 Deleted effective June 1, 2004

6.4 Deleted effective June 1, 2004

6.5 Deleted effective June 1, 2004

6.6 Deleted effective June 1, 2004

6.7 Deleted effective June 1, 2004

6.8 Deleted effective June 1, 2004

6.9 Deleted effective June 1, 2004

Figure 6.1 Enclosure requirements for fixed or stationary equipment

Figure 6.1 deleted effective June 1, 2004

6.10 Deleted effective June 1, 2004

6.11 Deleted effective June 1, 2004

7 Alternate Enclosure Material Considerations

Section 7 deleted October 16, 2000. Applicable requirements being relocated to Appendix A

7.1 Deleted October 16, 2000

7.2 Deleted October 16, 2000

7.3 Deleted October 16, 2000

7.4 Deleted October 16, 2000

7.5 Deleted October 16, 2000

7.6 Deleted October 16, 2000

7.7 Deleted October 16, 2000

Table 7.1 Alternative enclosure material consideration

Table 7.1 deleted October 16, 2000

ELECTRICAL INSULATION

8 Material Property Considerations

Revised 8 effective June 1, 2004

8.1 General

8.1.1 Mechanical and electrical properties of materials are to be judged with respect to the particular "end use" application. The requirements in this Section establish general minimum requirements for applications where the polymeric material is relied upon to reduce the risks of fire and electric shock.

Revised 8.1.1 effective June 1, 2004

8.1.2 These requirements do not cover the additional considerations that must be given to applications employing large masses of polymeric materials. Whether or not such materials protect against electric shock or injury to persons, consideration is to be given to the likelihood of ignition of the material by sources inside the product or by sources outside the product. See 21 for Flame Spread requirements to be applied to large mass applications.

Revised 8.1.2 effective June 1, 2004

8.1.3 These requirements supplement the requirements for enclosures in Section 4.

Revised 8.1.3 effective June 1, 2004

8.1.4 Figure 8.1 is to be used as a guide to determine the applicable material-property requirements. First, the construction features found in the end product are to be matched to the Figurative examples given in Figure 8.1. By referring back to Table 8.1, it can be determined which minimum property values are required for each of the typical constructions (Figurative examples).

Exception: End product tests may be used instead of pre-selection tests to determine if the material is acceptable in the application, as indicated in Table 8.2.

Note – As an example of using Table 8.1 and Figure 8.1, a polymeric material used in an application that most closely matches figurative example No. 7 of Figure 8.1, would be evaluated with respect to the mold-stress relief, resistance to creep, and maximum-use temperature properties indicated in Table 8.1.

Revised 8.1.4 effective June 1, 2004

8.1.5 Deleted effective June 1, 2004

8.1.6 To determine a polymeric material's performance profile, certain tests are to be performed according to the methods contained in the Standard for Polymeric Materials – Short Term Property Evaluations, UL 746A and the Standard for Polymeric Materials – Long Term Property Evaluations, UL 746B. These tests, general engineering considerations, and minimum performance levels are tabulated in Table 8.1. Specific applications may require different limits than are shown in the general case. Refer to 8.2 for considerations to be used in determining the acceptability of an insulating material that does not meet with the requirements tabulated in Table 8.1.

Revised 8.1.6 effective June 1, 2004

8.1.7 In establishing acceptable performance levels, consideration has been given to the service experience and to property values of presently available materials. Minimum performance characteristics have been grouped into four distinct levels based upon a material's flammability classification. The basis for the grouping is a relationship developed between resistance to ignition and persistence or rate of burning.

8.1.8 Nonrigid foamed materials – having a tensile or flexural modulus less than 0.69 gigapascals (100,000 lbf/in²), and a density less than 0.5 gram per cubic centimeter (31.3 lb/ft³) – are generally not considered acceptable for the direct or indirect support of live parts.

8.2 Evaluation of Materials Not Meeting Preselection Test Performance Levels in Table 8.1

Revised 8.2 effective June 1, 2004

8.2.1 Some materials may have performance characteristics less than the minimum required for the construction type (Figurative example) in Table 8.1. In such cases, the application can be considered in the context of the complete end product construction and special tests conducted to determine if the lower value can be accepted without increasing the likelihood of risk for the particular end-product.

Revised 8.2.1 effective June 1, 2004

8.2.2 Table 8.2 indicates which end-product tests, or other considerations such as increased thicknesses or spacings, may be used as alternatives to the requirements in Table 8.1.

Revised 8.2.2 effective June 1, 2004

Pages 21–24 deleted.

No Text on This Page

Figure 8.1
Figurative examples for Table 8.1

Figure 8.1 revised July 15, 1998

1.

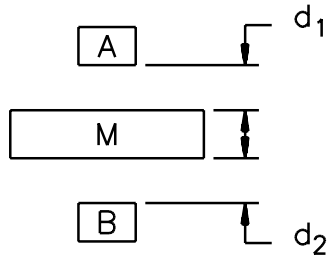

$d_1 + d_2 < S_a$
 WHERE $d_1, d_2 =$ THROUGH AIR SPACING
 $S_a =$ APPLICABLE THROUGH AIR SPACING REQUIREMENT

2.

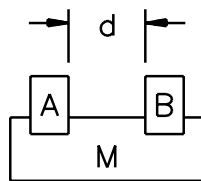

$d < 12.7\text{mm}$
 WHERE $d =$ OVER SURFACE SPACING

3.

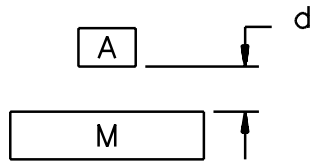

$0 \leq d < 0.8\text{mm}$
 WHERE $d =$ THROUGH AIR SPACING

4.

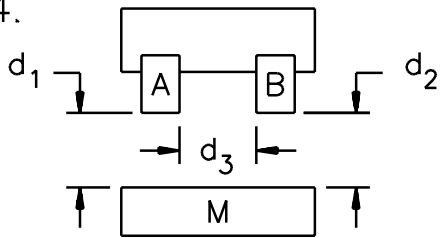

$d_1, d_2 < 0.8\text{mm}$
 $d_3 < 12.7\text{mm}$
 WHERE $d_1, d_2 =$ THROUGH AIR SPACINGS
 $d_3 =$ OVER SURFACE SPACING

Figure 8.1 (Cont.)
Figurative examples for Table 8.1

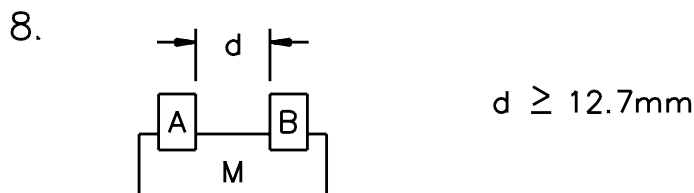
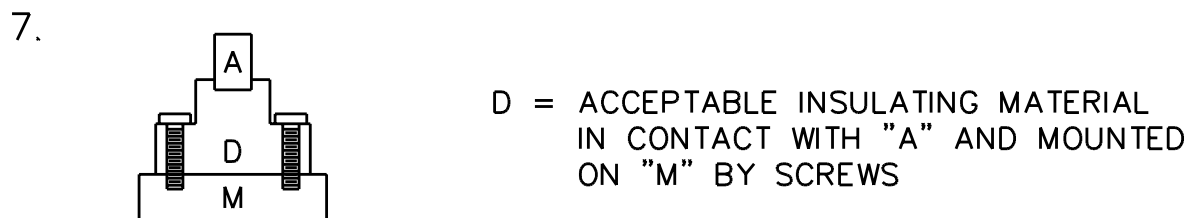
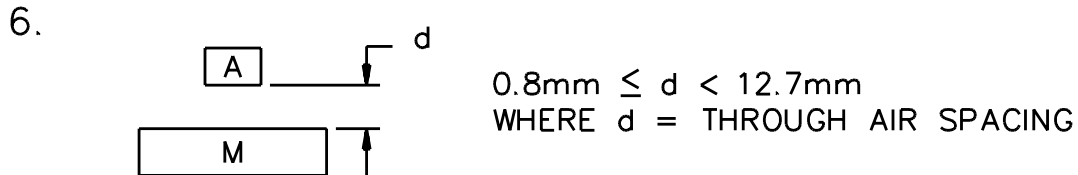
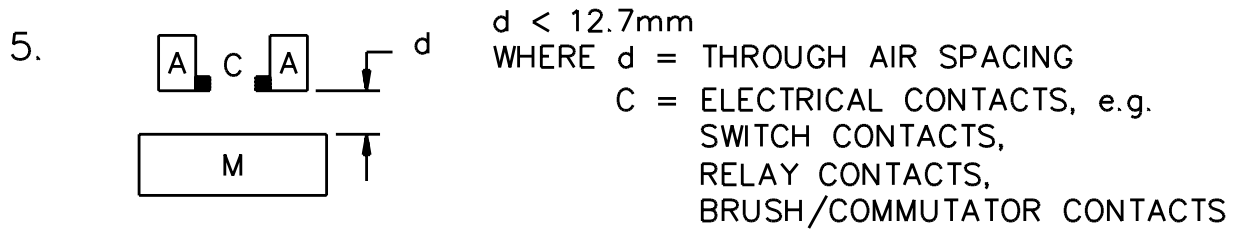

A = UNINSULATED LIVE PART

B = (1) UNINSULATED LIVE PART HAVING DIFFERENCE IN POTENTIAL FROM A, OR
(2) DEAD METAL PART THAT MAY BE GROUNDED IN SERVICE OR IS EXPOSED TO CONTACT.

M = POLYMERIC MATERIAL UNDER CONSIDERATION

Note: (1) ALL SPACINGS ASSUMED TO BE RELIABLY MAINTAINED.
(2) UNLESS SHOWN IN CONTACT WITH "M", ALL LIVE PARTS ARE SUPPORTED BY STRUCTURES NOT DEPENDENT ON "M".

Table 8.1
Material property considerations

Revised Table 8.1 effective June 1, 2004

Property	Test	Method	Units of PLC	Recommended levels related to flammability classification ^a				Applications ^b	Figurative examples from Fig. 8.1
				V-0 VTM-0	V-1 VTM-1	V-2 VTM-2	HB		
ELECTRIC STRENGTH	Volume – resistivity (Sec. 16)	UL 746A	Min Ohm-cm (dry)	50 x 10 ⁶	50 x 10 ⁶	50 x 10 ⁶	50 x 10 ⁶	Material serves as insulation between uninsulated live parts of opposite polarity or between uninsulated live parts and (1) dead metal parts that may be grounded in service or (2) any surface exposed to contact	(1), (2), (3), (8)
			Min Ohm-cm (after 90% humidity)	10 x 10 ⁶	10 x 10 ⁶	10 x 10 ⁶	10 x 10 ⁶		
	Dielectric strength (Sec. 12)	UL 746A	Min V (rms) (both dry & after 90% humidity)	5000	5000	5000	5000	Same as above	(1), (2), (3), (8)
TRACKING RESISTANCE	Comparative tracking index (CTI) (Sec.11)	UL 746A	Max ^c PLC					Material surface is in contact with or in close proximity (less than 1/32 inch (0.8mm)) to (a) uninsulated live parts of opposite polarity, or (b) uninsulated live parts and either (1) dead metal parts that may be grounded in service, or (2) any surface exposed to contact Higher CTI values are required where a greater degree of contamination is involved, as follows: Indoor equipment exposed to relatively clean environment	(2), (3), (4)
					4	4	4		
					3	3	3	3	Outdoor and indoor equipment exposed to moderate contaminate environments
	CTI	UL 746A	Max ^c PLC		2	2	2	2	Outdoor and indoor equipment exposed to severe contaminate environments
	Inclined-plane tracking (Sec. 15)	UL 746A	Min time (min) to track 25.4 mm at 2.5 kV excitation	60	60	60	60	Same as above for CTI, except that the application voltage range is 601 V-5 kV	(2), (3), (4), (8)
				300	300	300	300	Same as above for CTI, except that application voltage range 5,001 V-35 kV	(2), (3), (4), (8)

Table 8.1 Continued on Next Page

Table 8.1 Continued

Property	Test	Method	Units of PLC	Recommended levels related to flammability classification ^a				HB	Applications ^b	Figurative examples from Fig. 8.1
				V-0 VTM-0	V-1 VTM-1	V-2 VTM-2				
PERMANENCE	Dimensional change after water exposure (Sec. 27.2.1)	UL 746A	Max percent change	2	2	2	2	Same as Volume Resistivity above but also includes applications where the material maintains the relative positioning of live parts and the parts could be subjected to high humidity or moisture	(1), (2), (3), (4), (7), (8)	
DISTORTION UNDER LOAD	Heat deflection temperature under load or Vicat softening point or Ball pressure temperature (Sec. 30)	UL 746A	Min °C at 66 psi	10°C (18°F) greater than the use temperature but not less than 90°C	25°C greater than the use temperature but not less than 105°C (221°F)		Greater than the use temperature by the difference between 40°C and the ambient, but not less than 95°C	All applications except decorative parts	(1), (2), (3), (4), (5), (6), (7), (8)	
DIMENSIONAL CHANGE DUE TO EXTERNAL STRESSES	Resistance to Creep (Sec. 24A)	UL 746C		Resistance to creep should be evaluated in the specific application				All applications with mechanical stresses due to external sources	(1), (2), (3), (4), (5), (6), (7), (8)	
RESISTANCE TO ELECTRICAL IGNITION SOURCES	High current arc resistance to ignition (HAI) (Sec. 13)	UL 746A	Max PLC ^d	3	2	2	1	Material is in contact with or in close proximity to uninsulated live parts 0.8 mm (1/32 inch) for nonarcing parts or 12.7 mm (1/2 inch) for arcing parts	(1), (2), (3), (4), (5), (8)	
	Hot wire ignition HWI (Sec. 14)	UL 746A	Max PLC ^e	4	3	2	2	Material is in contact with or close proximity to uninsulated live parts [less than 0.8 mm (1/32 inch)]	(2), (3), (4), (8)	
MECHANICAL	Tensile or flexural strength; tensile, Izod, or Charpy impact (Sec. 24)	UL 746A	MPa KJ/m ² or J/m notch	Mechanical strength is judged in the application				Material maintains the relative positioning of live parts or encloses live parts	(2), (4), (7), (8)	
MAXIMUM USE TEMPERATURE	Relative thermal index (RTI) (Sec. 37 – 39)	UL 746A	Minimum °C	The maximum operating temperature of the part shall not exceed materials' temperature limit determined by the method, indicated in Table 33.1 (See Sections 33 – 39)				All applications except decorative parts	(1), (2), (3), (4), (5), (6), (7), (8)	
^a Materials classed as 5VA and 5VB only by the Vertical Burning Test described in the requirements for tests for flammability of plastic materials for parts in devices and appliances, UL 94, or a material when flame tested as used in the equipment, complies with the requirements in Flammability - 12 mm flame, Section 17, Flammability - 3/4-inch flame, Section 18, or Flammability - 127 mm (5 inch) flame, Section 19, shall be considered with respect to the recommended performance levels of a material classed as V-1										

Table 8.1 Continued on Next Page

Table 8.1 Continued

Property	Test	Method	Units of PLC	Recommended levels related to flammability classification ^a				Applications ^b	Figurative examples from Fig. 8.1																					
				V-0 VTM-0	V-1 VTM-1	V-2 VTM-2	HB																							
^b Materials located in nonhazardous-energy circuitry, as defined in the appropriate end-product standard, shall only be considered with respect to their flammability, distortion under load and mold stress relief, mechanical and maximum use temperature properties except the resistance to electrical ignition sources property may also be considered if the material is located less than 12.7 (1/2 inch) from arcing parts or sources of ignition.																														
^c <table border="1" style="width: 100%; border-collapse: collapse;"> <thead> <tr> <th colspan="2">CT1 Range – Tracking Index (Volts)</th> <th>Assigned PLC</th> </tr> </thead> <tbody> <tr> <td colspan="2">600 ≤ TI</td> <td>0</td> </tr> <tr> <td colspan="2">400 ≤ TI < 600</td> <td>1</td> </tr> <tr> <td colspan="2">250 ≤ TI < 400</td> <td>2</td> </tr> <tr> <td colspan="2">175 ≤ TI < 250</td> <td>3</td> </tr> <tr> <td colspan="2">100 ≤ TI < 175</td> <td>4</td> </tr> <tr> <td colspan="2">0 ≤ TI < 100</td> <td>5</td> </tr> </tbody> </table>										CT1 Range – Tracking Index (Volts)		Assigned PLC	600 ≤ TI		0	400 ≤ TI < 600		1	250 ≤ TI < 400		2	175 ≤ TI < 250		3	100 ≤ TI < 175		4	0 ≤ TI < 100		5
CT1 Range – Tracking Index (Volts)		Assigned PLC																												
600 ≤ TI		0																												
400 ≤ TI < 600		1																												
250 ≤ TI < 400		2																												
175 ≤ TI < 250		3																												
100 ≤ TI < 175		4																												
0 ≤ TI < 100		5																												
^d During the HAI test, the electrodes are to be positioned as indicated in 13.2 <table border="1" style="width: 100%; border-collapse: collapse;"> <thead> <tr> <th colspan="2">HAI Range – mean number of arcs to cause ignition</th> <th>Assigned PLC</th> </tr> </thead> <tbody> <tr> <td colspan="2">120 ≤ NA</td> <td>0</td> </tr> <tr> <td colspan="2">60 ≤ NA < 120</td> <td>1</td> </tr> <tr> <td colspan="2">30 ≤ NA < 60</td> <td>2</td> </tr> <tr> <td colspan="2">15 ≤ NA < 30</td> <td>3</td> </tr> <tr> <td colspan="2">0 ≤ NA < 15</td> <td>4</td> </tr> </tbody> </table>										HAI Range – mean number of arcs to cause ignition		Assigned PLC	120 ≤ NA		0	60 ≤ NA < 120		1	30 ≤ NA < 60		2	15 ≤ NA < 30		3	0 ≤ NA < 15		4			
HAI Range – mean number of arcs to cause ignition		Assigned PLC																												
120 ≤ NA		0																												
60 ≤ NA < 120		1																												
30 ≤ NA < 60		2																												
15 ≤ NA < 30		3																												
0 ≤ NA < 15		4																												
^e <table border="1" style="width: 100%; border-collapse: collapse;"> <thead> <tr> <th colspan="2">HWI Range – mean ignition time</th> <th>Assigned PLC</th> </tr> </thead> <tbody> <tr> <td colspan="2">120 ≤ IT</td> <td>0</td> </tr> <tr> <td colspan="2">60 ≤ IT < 120</td> <td>1</td> </tr> <tr> <td colspan="2">30 ≤ IT < 60</td> <td>2</td> </tr> <tr> <td colspan="2">15 ≤ IT < 30</td> <td>3</td> </tr> <tr> <td colspan="2">7 ≤ IT < 15</td> <td>4</td> </tr> <tr> <td colspan="2">0 ≤ IT < 7</td> <td>5</td> </tr> </tbody> </table>										HWI Range – mean ignition time		Assigned PLC	120 ≤ IT		0	60 ≤ IT < 120		1	30 ≤ IT < 60		2	15 ≤ IT < 30		3	7 ≤ IT < 15		4	0 ≤ IT < 7		5
HWI Range – mean ignition time		Assigned PLC																												
120 ≤ IT		0																												
60 ≤ IT < 120		1																												
30 ≤ IT < 60		2																												
15 ≤ IT < 30		3																												
7 ≤ IT < 15		4																												
0 ≤ IT < 7		5																												

Table 8.2
Additional considerations for materials not meeting pre-selection test performance levels

Revised Table 8.2 effective June 1, 2004

Test		Additional end product considerations
1.	Volume resistivity	Conduct end product leakage current test – see 16.1
2.	Dielectric strength	Use thicker material section – see 12.1
3.	Comparative tracking index (CTI)	Increase spacings
4.	Inclined Plane tracking	Increase spacings
5.	Permanence	Conduct end product conditioning test – see 27.2
6.	Distortion under load	Conduct end product mold stress-relief distortion test where stress is internal (i.e., results from molding or fabrication process) – see 30.1
7.	High current arc ignition (HAI)	Conduct end product arc resistance test – see 13.3 and 13.4

Table 8.2 Continued on Next Page

Table 8.2 Continued

Test		Additional end product considerations
8.	Hot wire ignition (HWI)	Conduct end product abnormal overload test, or end-product Glow-Wire Test – see Hot-Wire Ignition (HWI) – Abnormal Overload Test, Section 14
9.	Maximum Use Temperature	Conduct end product thermal aging test – see Relative Thermal Index, Section 36, Relative Thermal Capability, Section 37, and Temperature Excursions Beyond the Maximum Use Temperature, Section 39

9 Internal Barriers

9.1 A barrier or liner employed where spacings are unacceptable between uninsulated live parts of opposite polarity or between uninsulated live parts and accessible metal parts, shall comply with all of the following:

- a) The barrier or liner shall be of insulating material that complies with Table 8.1.
- b) The minimum thickness of the barrier or liner shall be at least 0.71 mm, except that 0.33 mm is acceptable where used in conjunction with an air space of at least on-half of the required clearance.

Exception No. 1: The thickness of the barrier may be less than that specified in 9.1(b) providing that the results of a separate investigation indicate acceptable performance. Resin bonded mica 0.15 mm thick is considered to meet this thickness requirement when its use is limited to applications where it is protected from mechanical abuse or movement. Polyethylene terephthalate (PETE) film 0.18 mm thick, or greater, is considered to meet the thickness requirement.

- c) The barrier or liner shall be equivalent to vulcanized fiber in mechanical strength (tensile strength, tear resistance, puncture strength, Cold Flow, and the like) if likely to be subject to mechanical damage. See Polymeric Materials – Industrial Laminates, Filament Wound Tubing, Vulcanized Fibre, and Materials used in Printed Wiring Boards, UL 746E, Vulcanized Fibre, Section 9, for specific performance indexing data on vulcanized fiber.

Revised 9.1 effective June 1, 2004

9.2 A material, that is used as a physical barrier against contact with parts that can cause injury to persons during intended operation and user servicing, or to restrict access to circuitry where there is an increased risk of electric shock, shall comply with the requirements in Table 8.1.

Revised 9.2 effective June 1, 2004

Table 9.1
Material requirements for internal barriers

Table 9.1 deleted effective June 1, 2004

9.3 Deleted effective June 1, 2004

PERFORMANCE CRITERIA

10 General

10.1 Sections 10– 39 indicate the test methods and minimum performance levels specified in Table 4.1 and Table 8.1. Some materials may not comply with all of the general properties required for the application. In such cases, the application must be further considered to determine if the material's characteristics are not acceptable, or if a reduced value can be accepted without increasing the likelihood of risk for the particular end-product.

Revised 10.1 effective January 1, 2004

10.2 Many of the sections make reference to one or more performance tests on the end-product that can be used to determine the acceptability of a material where performance does not meet the minimum requirements.

ELECTRICAL

11 Comparative Tracking Index (CTI)

11.1 A risk of fire or electric shock may develop within electrical equipment as a result of electrical tracking of insulating material that is exposed to various contaminating environments and surface conditions. The comparative tracking index provides a comparison of the performance of insulating materials under wet and contaminated conditions.

11.2 Comparative tracking index (CTI) is determined by the method described in the Standard for Polymeric Materials – Short Term Property Evaluations, UL 746A, Recommended Method for Determining the Comparative Tracking Index of Solid Insulating Materials Under Moist Conditions. The comparative tracking voltage is an index and is not directly related to the suitable operating voltage in actual service.

11.3 The comparative tracking index provides an indication of the relative track resistance of the material at voltages up to 600V. The incline plane tracking test described in Inclined Plane Tracking, Section 15 should be used to evaluate the track resistance of materials at voltages that are greater than 600V.

11.4 As indicated in Table 8.1, an insulating material that is in contact with or close proximity to less than 0.8 mm (1/32 inch) uninsulated live parts or such parts and dead metal parts that may be grounded in service or any surface exposed to contact, shall have a maximum CTI PLC of 4 for indoor equipment in a relatively clean environment; a maximum CTI PLC of 3 is required for most outdoor and indoor equipment that may be exposed to moderate contaminate environments; a maximum CTI PLC of 2 is required for equipment that is likely to be subjected to severe contaminate environments.

Exception: In lieu of demonstrating compliance through the use of a pre-selection test, The Proof Tracking Test, described in IEC 112, can be conducted on a portion of the product enclosure to determine compliance with the specified Proof Tracking Index (PTI) specified in the end-product standard.

11.4 revised July 7, 1999

11.5 The values specified in Table 8.1 are for reference, higher or lower values may be required in specific end-product equipment.

12 Dielectric Strength

12.1 If an enclosure of polymeric material is depended upon to serve as electrical insulation, it shall have a dielectric strength in the use thickness at 50 – 60 Hz of at least 5000 V, rms, both after conditioning for 40 hours at $23.0 \pm 2.0^{\circ}\text{C}$ ($73.4 \pm 3.6^{\circ}\text{F}$) and 50 ± 5 percent relative humidity and after conditioning for 96 hours to moist air having a relative humidity of 90 ± 5 percent at a temperature of $35.0 \pm 2.0^{\circ}\text{C}$ ($95.0 \pm 3.6^{\circ}\text{F}$).

13 High Current Arc Resistance to Ignition (HAI)

13.1 A polymeric material shall resist ignition to the levels shown in Table 8.1 when tested in accordance with the High Current Arc Resistance to Ignition Test described in the Standard for Polymeric Materials – Short Term Property Evaluations, UL 746A.

Exception: The high current arc resistance-to-ignition test need not be conducted for non-hazardous energy circuits.

13.2 During the test the electrodes are to be positioned as follows:

- a) If the live parts are located less than 0.8 mm (1/32 inch) from the polymeric material, then the electrodes are to be positioned on the surface of the material, or
- b) If the source of an arc for an arcing live part is located at least 0.8 mm (1/32 inch) but less than 12.7 mm (1/2 inch) from the material, the electrodes are to be positioned above the surface of the material at a distance equal to the minimum distance between the arc source and the material used in the application.

13.3 A material that does not comply with 13.1 may be evaluated by using the power (current, voltage, and power factor) of the circuit in the end product by conducting a short-circuit test using the procedures described in 49.1. (Arcing Test)

13.4 There shall be no ignition;

- a) Within 15 arcs for materials classed V-0,
- b) Within 30 arcs for materials classed V-1 and V-2, or
- c) Within 60 arcs for materials classed HB.

In addition, there shall not be a permanent carbon conductor path judged by application of a dielectric voltage-withstand potential between the live part and the adjacent part of different potential indicated in 49.1, as required in the end-product Standard but not less than 1000 volts, 60 hertz for 1 minute.

13.4 revised July 17, 1997

13.5 The end-product tests described in 49.1 may show that the shape, over-surface distance, thickness, heat sinks, and the like, provide more ignition resistance than occurred as a result of testing plastic specimens using the method described in the Standard for Polymeric Materials – Short Term Property Evaluations, UL 746A.

14 Hot-Wire Ignition (HWI) – Abnormal Overload Test or Glow-Wire End-Product Test

14.1 General

14.1.1 Materials that do not comply with the minimum hot-wire ignition levels shown in Figure 5.1, Tables 7.1, 8.1 or 9.1 may be evaluated by an abnormal overload test or the glow-wire end-product test. The abnormal overload test passes abnormal currents through current-carrying members as described in 14.2. Over-current values and times are shown in Table 50.1 as a function of the circuit over-current device rating. The glow-wire end-product test subjects the end-product to an electrically heated wire. Glow-wire test temperatures are shown in Table 73.1 and are determined by end-product use.

Exception No. 1: The abnormal overload test or the glow-wire end-product test need not be conducted if the electrically live parts are spaced 0.8 mm (1/32 inch) or more from the material.

Exception No. 2: The abnormal overload test or the glow-wire end-product test need not be conducted for non-hazardous energy circuits.

14.1.1 revised July 15, 1998

14.2 Abnormal overload test

14.2.1 A polymeric material shall be capable of withstanding the temperatures that are generated during or as a result of the abnormal overload test described in 50.1 and 50.2 without ignition.

14.2.2 If there is no overcurrent protective device as part of the equipment or it cannot be relied upon, evaluation shall be based upon the available energy to the end-product using percentages of the intended branch-circuit overcurrent device, but not less than a 30 A normal-acting protective device.

14.2.3 If the overcurrent protective device is part of the equipment, it shall be relied upon only if the protector is not user-serviceable unless substitution of a higher-rated protector value is prevented by keying, other constructional features, or if there is a permanent marking limitation.

14.3 Glow-wire end-product test (GWEPT)

Revised 14.3 effective June 1, 2004

14.3.1 A polymeric material shall be capable of withstanding the effects of an electrically heated wire as described in 73.1.1 – 73.6.2. The specimen is considered to have satisfactorily withstood the glow-wire end-product test if either:

- a) There is no ignition, or
- b) All flaming and glowing of the specimen, the parts surrounding the specimen, and (if a material was used other than the tissue paper/pinewood board) the flaming particle indicator, ceases within 30 ± 1 s after removal of the glow-wire. The results are not acceptable if the specimen, the parts surrounding the specimen, or the flaming particle indicator are completely consumed.

14.3.1 added April 12, 1995

15 Inclined Plane Tracking

15.1 The inclined plane tracking test described in the Standard for Polymeric Materials – Short Term Property Evaluations, (UL 746A), provides an indication of the relative track resistance of the material at voltages that are greater than 600 V, but less than 35 kV.

15.2 As indicated in Table 8.1, an insulating material that is in contact with or close proximity to uninsulated live parts or such parts and dead metal parts that may be grounded in service or any surface exposed to contact, shall not track beyond one inch in less than 300 minutes using the time-to-track method. For materials subjected to voltage stresses between 5,001 V and 35 kV.

Exception: A minimum 60 minute time-to-track time is required for materials subjected to voltage stresses between 601 V and 5 kV.

16 Volume Resistivity

16.1 The volume resistivity of the polymeric material shall not be less than:

- a) 50 megohm-centimeters after conditioning for 40 hours at $23.0 \pm 2.0^\circ\text{C}$ ($73.4 \pm 3.6^\circ\text{F}$) and 50 ± 5 percent relative humidity.
- b) 10 megohm-centimeters immediately after exposure for 96 hours to moist air having a relative humidity of 90 ± 5 percent at a temperature of $35.0 \pm 2.0^\circ\text{C}$ ($95.0 \pm 3.6^\circ\text{F}$).

Exception: A material that exhibits a low value of volume resistivity may be considered acceptable, provided that the equipment complies with the leakage-current requirements in 16.3.

16.2 The volume resistivity is to be determined in accordance with the Standard for Polymeric Materials – Short Term Property Evaluations, UL 746A.

16.3 The leakage current of a cord-connected appliance rated for a nominal 120 V supply when tested in accordance with 72.1 – 72.5 shall not be more than:

- a) 0.5 mA for an ungrounded (two-wire) portable, stationary, or fixed appliance,
- b) 0.5 mA for a grounded (three-wire) portable appliance, and
- c) 0.75 mA for a grounded (three-wire) stationary or fixed appliance employing a standard attachment plug rated 20 A or less.

16.4 Leakage current refers to all currents, including capacitively coupled currents, which may be conveyed between exposed conductive surfaces of an appliance and ground or other exposed conductive surfaces of an appliance.

FLAMMABILITY

17 Flammability – 12 mm Flame

17.1 When equipment is tested as described in 51.1 – 51.6, the material shall not flame for more than 1 minute after two 30-second applications of a test flame, with an interval of 1 minute between applications of the flame. The results are not acceptable if the sample is completely consumed.

Exception: Parts that are molded from materials that are classed as 5VA, 5VB, V-0, V-1, or V-2 by the vertical burning test described in UL 94, need not be subjected to the flammability test described in 51.1 – 51.6.

17.1 revised July 17, 1997

18 Flammability – 3/4-Inch Flame

18.1 When equipment is tested as described in 52.1 – 52.5, the material shall not flame for more than 1 minute after two 30-second applications of a test flame, with an interval of 1 minute between applications of the flame. The results are not acceptable if the sample is completely consumed.

Exception: Parts that are molded from materials that are classed as 5VA, 5VB, V-0, V-1, or V-2 by the vertical burning test described in UL 94, need not be subjected to the flammability test described in 52.1 – 52.5.

18.1 revised July 17, 1997

19 Flammability – 127 mm (5 Inch) Flame

19.1 Except as indicated in the Exception to 53.1, when equipment is tested as described in 53.1 – 53.5, all of the following results shall be obtained:

- a) The material shall not continue to burn for more than 1 minute after the fifth 5-second application of the test flame, with an interval of 5 seconds between applications of the flame,
- b) Flaming drops or flaming or glowing particles that ignite surgical cotton 305 mm (12 inch) below the test specimen shall not be emitted by the test sample at any time during the test, and
- c) The material shall not be destroyed in the area of the test flame to such an extent that the integrity of the part is affected with regard to containment of fire.

Exception: Parts that are molded from materials that are classed as 5VA by the five inch burning test described in UL 94, need not be subjected to the flammability tests described in 53.1 – 53.5.

19.1 revised July 17, 1997

Pages 37–38 deleted.

20 Enclosure Flammability – 746-5VS

20.1 Test criteria

20.1.1 When tested as described in 54.1.1 – 54.2.7, coated materials shall:

- a) Not have any plaques which burn with flaming or glowing combustion, or both, for more than 5 seconds after removal of the flame.
- b) Not have any plaques which drip flaming particles that ignite the dry absorbent surgical cotton located 305 mm (12 inch) below the test plaque.
- c) Not have any plaques that exhibit burn through.

20.1.2 If only one plaque from a set of five fails to comply with the requirements, another set of five plaques is to be tested. All plaques from this second set shall comply with the requirements in order for the material in that thickness to be considered acceptable.

21 Enclosure Flammability – Large Mass Considerations

21.1 A polymeric material enclosure having in any single unbroken section, a projected surface area greater than 0.93 m² (10 ft²) or a single linear dimension greater than 1.83 m (6 ft) shall have a maximum flame-spread rating of 200 as determined by the requirements for tests for surface burning characteristics of building materials, UL 723, or the radiant-panel test in the requirements for tests for flammability of plastic materials for parts in devices and appliances, UL 94, may be used optionally to determine the flame spread characteristics of the material, in noncritical applications.

Exception: If the projected surface area is broken with a minimum 305 mm (12 inch) fire separation, or the polymeric material is used for the enclosure of equipment not permanently affixed to a power supply source, then the radiant panel test described in the requirements for tests for flammability of plastic materials for parts in devices and appliances, UL 94, shall be used to determine the flame spread characteristics of the material. The material shall have a maximum flame spread index of 200 as determined by the radiant panel test.

22 Flame-Retardant Coatings

22.1 General

22.1.1 The requirements in Section 22 and Flame-Retardant Coatings Test, Section 55 cover flame-retardant coatings that are employed on enclosures of polymeric materials in order to comply with the applicable flame test requirements (refer to Portable Appliances, Section 5 and Fixed or Stationary Equipment, Section 6 of this Standard).

22.1.2 The coating/enclosure material combination may be considered equivalent to a material possessing the applicable minimum flammability classification providing:

- a) The basic polymeric enclosure material is classified at least HB by the test method described in the requirements for tests for flammability of plastic materials for parts in devices and appliances, UL 94,
- b) Samples of the base material with the flame-retardant coating properly applied are found to comply, both before and after conditioning, with the minimum required flammability classification and adhesion tests,
- c) Additional coatings applied to the enclosure for coloring, finish, and the like do not adversely affect the complete enclosure with respect to its flammability classification,
- d) The addition of the flame-retardant coating does not adversely affect the insulating characteristics of the enclosure. This characteristic may not be a factor in all equipment designs, and
- e) An acceptable process-control program is to be established by the manufacturer at the location where the flame-retardant coating is applied to the enclosure material.

22.1.2 revised July 15, 1998

22.1.3 In all cases, the flame-retardant coating shall comply with the requirements of Section 22 and Flame-Retardant Coatings Test, Section 55 and the base enclosure material shall be acceptable for the temperatures that are encountered in the end product.

22.1.4 The tests in 22.2.1, 55.1.1.1 – 55.1.6.1 apply to the coating/material interface when it is exposed to a maximum use temperature of 60°C (140°F).

22.2 Test criteria

22.2.1 Both before and after completing the conditioning described in 55.1.1.1, 55.1.2.1 and 55.1.3.2, the specimens shall be tested to determine that:

- a) The flammability classification is essentially the same or better than that of the unconditioned samples,
- b) The specimens do not exhibit any evidence of flaking, cracking, or blistering of the coating after the test described in 55.1.4.3, and

- c) The impact and/or flexural strength properties have not been reduced by more than 50 percent from the as-received (or unconditioned) value.
- d) The surface resistivity of the specimens.

22.2.2 When the maximum use temperature exceeds 60°C (140°F), the acceptability of the coating/material interface is to be determined by a long-term thermal-aging study of the critical properties, including flammability, adhesion, and flexural or impact strength. Refer to the Standard for Polymeric Materials – Long Term Property Evaluations, UL 746B, for thermal-aging test procedures.

MECHANICAL

23 Crushing Resistance

23.1 Equipment that is not easily moved from one place to another during intended use, shall withstand a 1 minute application of the crushing force described in 56.1 without resulting in any of the following:

- a) Reduction of spacings below the minimum acceptable values.
- b) Making bare live parts or internal wiring accessible to contact.
- c) Such breakage, cracking, rupture, and the like as to produce an adverse effect on the insulation.
- d) Producing any other condition that would increase the likelihood of electric shock or fire, or both, during use of the equipment.

24 Resistance to Impact

24.1 The equipment shall withstand the impact described in 57.1 or 57.3 (whichever is applicable) without occurrence of any of the following:

- a) Making uninsulated live parts accessible to contact (use the accessibility probe of the product standard for this evaluation);
- b) Producing a condition that might affect the mechanical performance of the equipment; or
- c) Producing a condition that would increase the likelihood of an electric shock.

24.2 With reference to 24.1(b), cracking or denting of the enclosure is not to affect the function of any safety controls or constructional features such as thermostats, overload protective devices, waterseals, or strain relief. Cracking or denting of the enclosure is not to result in exposure of moving parts capable of causing injury to persons.

24.3 With reference to 24.1(c), the equipment is to comply with the dielectric voltage-withstand requirements applicable to the equipment after being subjected to the impact.

DIMENSIONAL CHANGE OF POLYMERIC PARTS

24A Creep

Section 24A added July 15, 1998

24A.1 Creep is defined as the dimensional change with time of a material under load. If a constant load is applied to a polymeric material, the initial dimensional change is predictable from the stress-strain modulus but, with time, the dimensional change continues to increase slowly until a point is reached at which the elongation suddenly again increases or rupture occurs. From experience, these effects are considered not to apply to rigid thermoset materials.

24A.2 Creep can occur when a polymeric part is under any type of long-time loading (for example, bending, compressive, or tensile loading, leaf or coil springs, or gravity).

24A.3 Where the end-product application is such that the creep is self-relieving, 300 hours at normal operating temperature, and with maximum loading, determines the effect of plastic flow. Creep is to be considered self-relieving if the stress is eliminated due to the change in dimension of the polymeric part.

24A.4 Where the end-product application is such that the creep is not self-relieving, such as when the external force is provided by gravity, 1,000 hours at normal operating temperature, and with maximum loading, determines the effect of plastic flow.

24A.5 As a result of the above, there is to be no warpage of distortion that:

- a) interferes with normal operation or servicing,
- b) results in accessibility of live parts,
- c) reduces electrical spacings below the level necessary to comply with the applicable requirements pertaining to dielectric strength and leakage current,
- d) for outdoor-use products, exposes internal components to the effects of weathering or water, and
- e) results in an unacceptable reduction of the pressure involved in metal-to-metal joints relied upon for safety including joints providing a bonding path and joints serving as current carrying parts.

24A.6 Manufacturer's data concerning the creep characteristics of material can be used for creep analysis. In applying such data, consideration is to be given to the similarity of the test method to the end application. The more nearly alike the environmental conditions, the geometry of the parts, and the stresses of both the test and the end application, the more valid a prediction can be made based on the test data.

No Text on This Page

PERMANENCE

25 Permanence

25.1 General

25.1.1 The tests indicated in 25.2.1 – 25.4.1 may be used as a relative measure of a material's ability to withstand relief of molding stresses while under the influence of elevated temperature. In applications where the distortion temperature is less than the values indicated in the applicable table, the results may be judged on the basis of the results of the mold stress-relief distortion test referred to in 30.1.

25.2 Vicat softening point

25.2.1 The vicat softening point shall be at least 25°C (45°F) greater than the use temperature but not less than 105°C (221°F) when tested in accordance with the Standard for Polymeric Materials – Short Term Property Evaluations (UL 746A).

25.3 Heat deflection temperature

25.3.1 The heat deflection temperature shall be at least 10°C (18°F) greater than the use temperature but not less than 90°C (194°F) when tested in accordance with the Standard for Polymeric Materials – Short Term Property Evaluations (UL 746A).

25.4 Ball pressure temperature

25.4.1 The ball pressure temperature shall be at least equal to 40°C (72°F) greater than the use temperature minus the ambient temperature, but not less than 95°C (203°F), when tested in accordance with the Standard for Polymeric Materials – Short Term Property Evaluations (UL 746A).

26 Ultraviolet Light Exposure

26.1 A polymeric material used for the enclosure of electrical equipment that will be exposed to an UV weathering source shall be acceptably resistant to degradation when exposed to the test described in 58.1.1 – 58.2.11.

26.2 Table 26.1 summarizes the minimum property retention limitations after UV conditioning. The flammability classification of base samples of the material in the thinnest part thickness, and any color under consideration, shall not be reduced as a result of 720 hours of twin enclosed carbon-arc (ASTM G151 and G153) or 1000 hours of xenon-arc (ASTM G151 and G155), weatherometer conditioning. The average physical property values after UV conditioning shall not be less than 70 percent of the unconditioned value when the standardized small-scale physical tests indicated in Table 26.1 are performed. See 58.2.3.

Exception No. 1: Where it is not practical to conduct the Tensile, Izod, or Charpy impact test using the standard specimens, the procedure of 58.2.7 – 58.2.11 and the impact equipment of Figures 58.1 and 58.2 may be used on representative sections of the equipment's enclosure.

Exception No. 2: If the impact value for an enclosure material that has been tested in accordance with the requirements in this section has exhibited less than 70 percent retention but at least 25 percent retention of the impact property, it is considered acceptable provided that all of the following results are obtained:

a) The unconditioned equipment complies with the resistance to impact requirement levels shown in Table 26.2, and

b) The specimens exposed to the 720 hour twin enclosed carbon-arc or 1000 hour xenon-arc UV conditioning have retained at least 80 percent of the 360 hour twin enclosed carbon-arc or 500 hour xenon-arc UV conditioning impact level. As an alternative, this UV conditioning may be conducted for a longer period of time in 360 hour (carbon-arc) or 500 hour (xenon-arc) increments providing the final exposure impact level is not less than 80 percent of the previous increment's impact level.

26.2 revised October 16, 2000

Table 26.1
Minimum property retention limitations after ultraviolet light and water immersion conditioning

Table 26.1 revised July 15, 1998

Property	Ultra-violet light ^a	Water immersion ^b
Flammability Classification	Unchanged	Unchanged
Tensile or Flexural Strength ^c	70 Percent	50 Percent
Tensile, Izod or Charpy Impact ^c	70 Percent	50 Percent

^a 720 hours twin enclosed carbon-arc or 1000 hours xenon-arc exposure. See 58.1.1 – 58.2.11.

^b 7 days at 70°C. See 59.1.

^c For functional support, the test methods are tensile strength and flexural strength. For Impact Resistance the test methods are Tensile, Izod, or Charpy impact. See Table 58.1.

Table 26.2
Unconditioned ball-impact requirements for equipment exposed to UV radiation^a

Percent retention of property after UV conditioning ^b	Impact level for ball-impact test on unconditioned specimens foot-pounds (joules)
70 or more	5.0 (6.8)
50 – 69	10.0 (13.6)
25 – 49	20.0 (27.2)
Less than 25	Not acceptable

^a For other than easily moved hand held and counter supported equipment.

^b 720 hours twin enclosed carbon-arc or 1000 hours xenon-arc exposure or after the final exposure if longer exposures are conducted as described in 26.2.

27 Water Exposure and Immersion

27.1 General

27.1.1 A polymeric material used for the enclosure of electrical equipment intended for outdoor installation shall not be appreciably degraded because of exposure to water. The acceptability of the material's resistance to such degradation may be judged by the procedure described in 27.1.2, 59.1 and 59.2

27.1.2 Table 26.1 summarizes the minimum property retention limitations after exposure to water. The flammability classification of base samples of the material in the thinnest part thickness, and any color under consideration shall not be reduced as a result of the 7 day at 70°C (158°F) conditioning described in 59.1. The average physical-property values after the water exposure and immersion conditioning shall not be less than 50 percent of the original (non-water conditioned) value when the standardized small-scale physical test in Table 26.1 are performed.

27.2 Dimensional change

27.2.1 If a material exhibits a dimensional change greater than 2.0 percent after immersion for 168 hours in distilled water, as described in the Standard for Polymeric Materials – Short Term Property Evaluations (UL 746A), end-product tests are to be performed to determine if the change in dimension created by the service environment might cause:

- a) A reduction of spacings leading to excessive leakage currents,

- b) A dielectric breakdown after such exposure, or
- c) Warpage or swelling that might impair the acceptable operation of the equipment.

SPECIAL END-USE CONSIDERATIONS

28 Abnormal Operation

28.1 When tested as described in 60.1, there shall not be ignition of the material, exposure to live parts, nor glowing or flaming of the combustible material that the equipment is placed on or is draped. Warping, shrinkage, expansion, or cracking of the material is not objectionable provided that there is no ignition of the combustible material indicators in proximity to the enclosure.

29 Severe Conditions

29.1 The no-load current input to the equipment that has completed the procedures described in 61.1 without burning out electrically shall not be greater than 150 percent of the no-load current input of the equipment, measured on an unconditioned sample.

29.2 Burnout of the equipment during the conditioning described in 61.1 shall not result in:

- a) Flaming of the enclosure that persists for more than 1 minute, or
- b) Ignition of the white tissue paper or cheesecloth indicators in proximity to the enclosure.

THERMAL

30 Mold Stress-Relief Distortion

30.1 Conditioning of the equipment as described in 62.1 or 62.2, whichever is applicable according to Figure 5.1 or 6.1, shall not cause softening of the material as determined by handling immediately after the conditioning, nor shall there be shrinkage, warpage, or other distortion as judged after cooling to room temperature, that results in any of the following:

- a) Reduction of spacings between uninsulated live parts of opposite polarity, uninsulated live parts and accessible dead or grounded metal, uninsulated live parts and the enclosure below the minimum acceptable values.
- b) Making uninsulated live parts or internal wiring accessible to contact, or defeating the integrity of the enclosure so that acceptable mechanical protection is not afforded to internal parts of the equipment.
- c) Causing a condition that results in the equipment not complying with the power-supply-cord strain-relief requirements, if applicable.
- d) Causing interference with the intended operation or servicing of the equipment.

Exception: The conditioning described in 62.1 and 62.2 is not required for rigid thermosetting materials or for low-pressure foamed molded parts.

31 Input to Motor

31.1 After being conditioned as described in 62.2 and when operated at no-load and rated voltage, as indicated in 63.1, the equipment shall have an input current no more than 150 percent of the no-load current measured during the applicable input test conducted on an unconditioned sample.

32 Strain-Relief Test after Mold Stress-Relief Distortion

32.1 After the test samples have cooled to room temperature following the oven conditioning described in 62.1 or 62.2 (whichever is applicable according to Figure 5.1 or 6.1), the sample shall be subjected to the strain-relief test and shall comply with the requirements applicable to the equipment.

33 Temperature Considerations – General

33.1 It has been shown that material properties are a continuous function of temperature and time. At relatively low temperatures the tendency for degradation is reduced while at elevated temperatures, there is a more rapid degradation. A single temperature rating can not be assigned to a material, since such a rating would be a function of: the generic material type, additives, and fillers; the properties required and levels of stress encountered in the application; the duty cycle and the effect of part failure with regard to increasing the risk of electrical shock, fire or injury to persons.

33.2 Table 33.1 and Sections 34 – 37 describe different approaches for assigning temperature limits to materials based upon the knowledge of the material and its application. Any of these methods may be employed to assign a temperature limit to the material. Temperature Considerations – Illustrative Example, Section 67, contains an illustrative example that describes how temperature considerations are applied.

33.3 Temperature Excursions Beyond the Maximum Use Temperature, Section 39, describes a procedure for determining an equivalent temperature where temperature excursions above the material's temperature limit are encountered or where the material may be exposed to cyclic temperatures during intended operation.

Table 33.1
Methods of material temperature limit considerations

Section	Methods of temperature limits	Synopsis of method
34	Functional-use thermal index	This is the most general approach for assigning material temperature limits. It does not require any information on the material formulation. The temperature limit is determined by the function that the material serves in specific applications.
35	Generic thermal index	Maximum temperature limits based upon the material's generic type (chemical structure, fillers, additives, etc.); no knowledge of the material's end-use function is required.
36	Relative thermal index	Material temperature limits based upon a relative comparison of long term critical material property retention with those of a control material having an acceptable field service history under various conditions and applications. Basic knowledge of the material's end use function is required.
37	Relative thermal capability	Material temperature limit based upon the material's use in a specific application where required material property stress levels are identified and controlled. This is the most specific approach for assigning material temperature limits. It requires knowledge of long term thermal aging properties (see Relative Thermal Index, Section 36) before this procedure may be used.

34 Functional-Use Temperature Indices

34.1 Table 34.1 presents a list of maximum temperature limits that have been assigned to materials regardless of generic type when used in applications that perform a specific function.

34.2 The functional-use temperature index is independent of thickness and pigmentation.

34.3 A polymeric material having a maximum operating temperature that does not exceed the value tabulated in Table 34.1 is acceptable if tests on finished parts, before and after mold-stress conditioning (refer to the Standard for Polymeric Materials – Short Term Property Evaluations, UL 746A) with regard to electrical and physical properties and a 7 day conditioning at 70°C (158°F) or 10°C (18°F) higher than the maximum use temperature whichever is higher, for flammability properties, demonstrate compliance with the requirements for the application in equipment. If the requirements after conditioning are the same as the requirements as-received and the test results are acceptable, the as-received tests can be waived.

Exception No. 1: The mold-stress conditioning is not required for rigid thermosetting materials and low-pressure foamed molded parts.

Exception No. 2: Flammability conditioning is not required if both of the following conditions are met:

a) The material does not exhibit a reduction in its flame-resistance properties as a result of long-term thermal aging (refer to the Standard for Polymeric Materials – Long Term Property Evaluations, UL 746B).

b) The thermal-aging program used for such determination included specimens having a thickness equal to or less than the wall thickness of the finished part.

34.4 A polymeric material having a maximum use operating temperature in excess of the value shown in Table 34.1, shall be considered acceptable if it complies with the requirements for Generic Thermal Indices (Section 35), Relative Thermal Indices, (Section 36), or Relative Thermal Capability (Section 37).

Table 34.1
Maximum temperature limits of polymeric material based upon its functional end-use application

Application Area	Temperature limits of polymeric material °C (°F)	
	Enclosure	Other Parts ^a
Portable, attended, intermittent-duty household equipment	80 (176)	65 (149)
All other portable equipment	65 (149)	65 (149)
All other equipment	50 (122)	50 (122)

^a Decorative parts are exempt from these temperature limits.

35 Generic Thermal Indices

35.1 Table 35.1 presents a list of materials, that have been assigned a generic thermal index based upon acceptable service experience, the chemical structure of the material, and a knowledge of the performance of the material in tests of insulating systems and electrical equipment. The assigned generic thermal index is applicable to each member of the generic material group.

35.2 Except for materials specified in Table 35.1, the generic thermal index of a material is to be considered 50°C (122°F).

35.3 Except for materials specified in Table 35.1, the generic thermal index of a material is independent of thickness and pigmentation.

35.4 A polymeric material having a maximum use operating temperature that exceeds the values shown in Table 35.1, shall be considered acceptable if it complies with the requirements for Functional-Use Temperature Indices (Section 34), Relative Thermal Indices (Section 36), or Relative Thermal Capability (Section 37).

Table 35.1
Relative thermal indices based upon past field-test performance and chemical structure^a

Table 35.1 revised October 16, 2000

Material	ISO Designation	Generic thermal index, °C
Polyamide (Type 6, 11, 12, 66, 610, or 612 nylon) ^b	(PA)	65
Polycarbonate ^b	(PC)	80
Polyethylene terephthalate – molding resin ^b	(PETP)	75
film (0.25 mm, 0.010 inch)	(PETP)	105
Polybutylene (polytetramethylene) terephthalate ^b	(PBTP)	75
Polyphenylene oxide ^j	(PPE – PS)	65
Polypropylene ^{b,h}	(PP)	65
Polyetherimide ^g	–	105
Polyphenylene Sulfide	(PPS)	130
Polymide film (0.25 mm, 0.010 inch max)	(PI)	130
Molded phenolic ^c	(PF)	150
Molded melamine ^{c,d} and molded melamine/phenolic ^{c,d} – specific gravity <1.55		130
specific gravity ≥1.55		150
Polytetrafluoroethylene	(PTFE)	180
Polychlorotrifluoroethylene	(PCTFE)	150
Fluorinated ethylene propylene	(FEP)	150
Urea Formaldehyde ^c	(UF)	100
Acrylonitrile– butadiene – styrene ^b	(ABS)	60
Silicone – molding resin ^{c,d}		150
Silicone rubber – molding resin	(SIR)	150
Room-temperature vulcanizing or heat-cured paste	(RTV)	105
Epoxy –	(EP)	
molding resin ^{c,d}		130
powder coating materials		105
casting or potting resin ^{b,i}		90
Molded diallyl phthalate ^{c,d}		130
Molded unsaturated polyester ^{c,d} alkyd (AMC), bulk (BMC), dough (DMC), sheet (SMC), thick (TMC), and pultrusion molding compounds	(UP)	
	(electrical)	105 ^e
	(mechanical)	130
Liquid crystalline thermotropic aromatic polyester ^h	(LCP)	130
Ligno-cellulose laminate		60

Table 35.1 Continued on Next Page

Table 35.1 Continued

Material	ISO Designation	Generic thermal index, °C
Vulcanized fiber		90
Cold-molded phenolic, melamine or		
melamine-phenolic compounds ^d –		
specific gravity <1.55		130
specific gravity ≥1.55		150
Cold-molded inorganic		200
(hydraulic-cement, etc.) compounds –		
Integrated mica, resin-bonded–		
epoxy, alkyd or		
polyester binder		130
phenolic binder		150
silicone binder		200
<p>^a Generic thermal index is for homopolymer resins only unless a specific copolymer or blend is indicated. In the case of alloys, the lowest generic index of any component shall be assigned to the composite.</p> <p>^b Includes glass-fiber reinforcement and/or talc, asbestos, mineral, calcium carbonate, and other inorganic fillers.</p> <p>^c Includes only compounds molded by high-temperature and high-pressure processes such as injection, compression, pultrusion, and transfer molding and match-metal die molding; excludes compounds molded by open-mold or low-pressure molding processes such as hand lay-up spray-up, contact bag, filament winding, rotational molding, and powder coating (fluidized bed, electrostatic spray, hot dip, flow coating).</p> <p>^d Includes materials having filler systems of fibrous (other than synthetic organic) types but excludes fiber reinforcement systems using resins that are applied in liquid form. Synthetic organic fillers are to be considered acceptable at temperatures not greater than 105°C.</p> <p>^e Except 130°C generic thermal index if the material retains at least 50% of its unaged dielectric strength after a 504-hour exposure at 180°C in an air circulating oven. Specimens are to be tested in a dry, as molded, condition. Specimens that are removed from the oven are to be cooled over desiccant for at least 2 hours prior to testing.</p> <p>^f Includes only wholly aromatic liquid crystalline thermotropic polyesters; wholly aromatic polyester/amides and wholly aromatic polyester/ethers; excluding amorphous, lyotropic and liquid crystalline aliphatic-aromatic polyesters which are aliphatic in the backbone chain or main chain, and substituted aromatic polyesters (except for methyl or aromatic).</p> <p>^g Includes only polyetherimide molding resin.</p> <p>^h Includes polypropylene copolymers containing not more than 25% ethylene comonomer, by weight.</p> <p>ⁱ Multi-part liquid epoxy materials incorporating acid anhydride or aromatic amine curing agents receive a 130°C generic thermal index.</p> <p>^j Includes only these polyphenylene oxide materials where PPE is the primary constituent.</p>		

36 Relative Thermal Index

36.1 The relative thermal index of a material is to be based upon an evaluation of long-term thermal-aging data obtained under a program described in the Standard for Polymeric Materials – Long Term Property Evaluations, UL 746B.

36.2 Essentially, the Standard for Polymeric Materials – Long Term Property Evaluations, UL 746B, procedure allows the thermal-aging characteristics of a material to be determined by measuring the changes in its properties to a predetermined level by aging at each of several elevated temperatures, plotting the logarithm of time at each temperature against the reciprocal of absolute temperature using the best-fit straight line by the least squares method of regression analysis. The time-temperature relationship may be expressed as:

$$\ln(t) = A + B/T$$

in which:

A is Constant (frequency factor)

B is Activation (Energy Constant)

T is Absolute temperature, °K (°C + 273.16) and

ln is Natural logarithm

36.3 A comparison of the thermal aging characteristics of the candidate material against those of a concurrently tested control material having proven field service, provides a means for estimating a relative thermal index level where the candidate material is expected to have an acceptable field service history. For each material, a number of relative thermal indices can be established, each index being related to a specific property, color, and thickness of the material.

36.4 A polymeric material having a use operating temperature higher than the applicable relative thermal index, shall be considered acceptable if it complies with the requirements for Functional Use Temperature Indices (Section 35) or Relative Thermal Capability (Section 37).

37 Relative Thermal Capability

37.1 The Relative Thermal Capability (RTC) of an organic insulating material relates to that maximum operating temperature at which the material can be expected to maintain critical properties and perform its intended mechanical or electrical function to the extent consistent with acceptable operation over the maximum expected life of the equipment. In general, the Relative Thermal Index (RTI) (see Section 36) may be used to represent the RTC provided consideration is given to the character of the critical (mechanical, electrical, impact) properties and minimum thickness of the material. A material may operate at a higher temperature than the RTI if the design of the equipment will allow a greater amount of thermal degradation. For such a material, it is necessary to define the following with respect to the critical property, using data obtained during a thermal endurance study in accordance with the Standard for Polymeric Materials – Long Term Property Evaluations, UL 746B:

- a) The resulting RTI from the UL 746B program.

- b) Life Equation Slope Parameter (B) as defined by 36.2.
- c) Excess performance factor (P) determined from the level of critical property in excess of the acceptable known value.
- d) Property – Time degradation characteristics for one or more aging temperatures, which can be used to determine that time (t₁) required for the property to degrade to a reduced fraction (f) of the unaged value, as well as normal end-of-life time (t₀).

37.2 The Relative Thermal Capability of a material cannot be measured by a superficial examination of material properties, as with a short term performance profile and long term relative thermal index. To determine the Relative Thermal Capability of a material, the level or value of the critical property of the material must be measured to determine the amount of degradation permissible in a specific end application.

37.3 An evaluation of the functional usage of the complete appliance or device is necessary in order to determine acceptable operating temperatures for materials used in appliances and equipment.

37.4 The thermal capability of a specific part is related to the thermal, mechanical, and electrical demands upon it in a particular application. Therefore, the results of a thermal capability evaluation for a given part and application cannot be extended to another end-use application even though the same material, and in some cases, the same part may be used.

37.5 The results of accelerated thermal aging studies, conducted in accordance with the Standard for Polymeric Materials – Long Term Property Evaluations, UL 746B, provide the basic information needed for the assessment of the thermal capability for a material used in a specific application.

37.6 The Relative Thermal Capability is calculated using the following equation:

$$RTC = [1 / (RTI + 273.16) - (\log F) / B]^{-1} - 273.16$$

in which:

F is the ratio t₁/t₀ determined at one or more aging temperatures,

t₀ is the normal end-of-life time based on 50 percent degradation, and

t¹ is calculated in terms of the reduced property percent, f = 50 / P.

P is the excess performance factor (see Relative Thermal Capability, Section 64).

37.7 Since the resulting RTC is based solely on projected long term effects resulting from slow chemical degradation reactions, it is essential to further determine that the RTC will not result in unacceptable performance with respect to any other short term-thermal effects, such as softening, warping, excessive weight loss indicating rapid decomposition, and the like. These effects are relatively easy to assess since by their very nature they will occur and can be measured in a short term time using standardized material tests. For the thermoplastics, the softening temperature limit can usually be determined by the results of either the Heat Deflection Under Load, Ball Pressure, or Vicat tests. For thermosets, Thermogravimetric Analysis or other equivalent analytical tests can usually determine the temperature of the onset of rapid decomposition.

37.8 If the resulting RTC calculated for one critical property (for example, mechanical with impact) results in an increased temperature limit above the RTI for another critical property (for example, mechanical without impact or electrical), then the latter property RTI must then be considered a limiting temperature which might in turn be considered as the basis for computing another RTC.

38 Relative Thermal Capability (Alternate)

38.1 The relative thermal capability of a material relates to its ability to perform the intended mechanical or electrical function in equipment when exposed to temperatures in excess of the relative thermal index, to the extent that short term thermal (softening) and long term exposure (thermal degradation) at the use temperature does not affect its functional usage. Evaluation of the relative thermal capability of the material used in a specific application requires the use of thermal aging on actual parts, using the procedures described in this section.

38.2 The thermal capability of a material cannot be measured by a simple examination of material properties. Rather, the thermal capability of a material may only be determined by analyzing measured changes in material property levels after exposure to elevated temperatures over a period of time, along with a thorough knowledge of the functional requirements for the material in the specific application.

38.3 An evaluation of the functional usage of the complete appliance or device is necessary in order to determine acceptable operating temperatures for materials used in appliances and equipment.

38.4 The thermal capability of a specific part is related to the thermal, mechanical, and electrical demands upon it in a particular application. Therefore, the results of a thermal capability evaluation for a given part and application cannot be extended to another end-use application even though the same material, and in some cases, the same part may be used.

38.5 The results of accelerated thermal aging studies, conducted in accordance with the Standard for Polymeric Materials – Long Term Property Evaluations, UL 746B, provide the basic information needed for the assessment of the thermal capability for a material used in a specific application.

38.6 Using the materials long term heat aging data from the most critical property required by the application, a relative thermal capability profile line can be generated having the same slope as the best fit material endurance profile line but displaced such that it passes through the point defined by the maximum use application temperature and the correlation factor. The example in Temperature Considerations – Illustrative Example (Alternate RTC), Section 68 (shown in Figure 38.1) graphically explains how the relative thermal capability profile line is constructed and used. Employing inverse temperature-logarithm hours graph paper, draw the relative thermal endurance profile of the material property under study and then generate the relative thermal capability profile by:

- a) Drawing a vertical line at the assigned relative thermal index of the material, (1) until it intersects the materials relative thermal endurance profile, (2). The value of the ordinate at this point of intersection is an estimate of the correlation factor, (A).
- b) Drawing a horizontal line at the point of intersection, (2), to the maximum part temperature point (3).
- c) Drawing a line parallel to the thermal endurance profile that passes through the maximum part temperature point, (3), determined in step B.

38.7 In order to be considered acceptable following the conditioning described in 61.1 and 61.2, the material shall not;

- a) Have its flammability classification changed below an acceptable level,
- b) Have a reduction in mechanical or electrical strength, or
- c) Become softened to a value where:
 - 1) The material cannot provide mechanical support of electrical conductors and parts, or
 - 2) There is a reduction of spacings between uninsulated live parts of opposite polarity, uninsulated live parts and accessible dead or grounded metal below the minimum acceptable values, or
 - 3) Uninsulated live parts or internal wiring are accessible to contact, or
 - 4) A condition is created that results in the equipment not complying with the power supply cord strain relief requirements, if applicable, or
 - 5) Interference with the operation or servicing of the equipment occurs.

Figure 38.1
Determination of the relative thermal capability

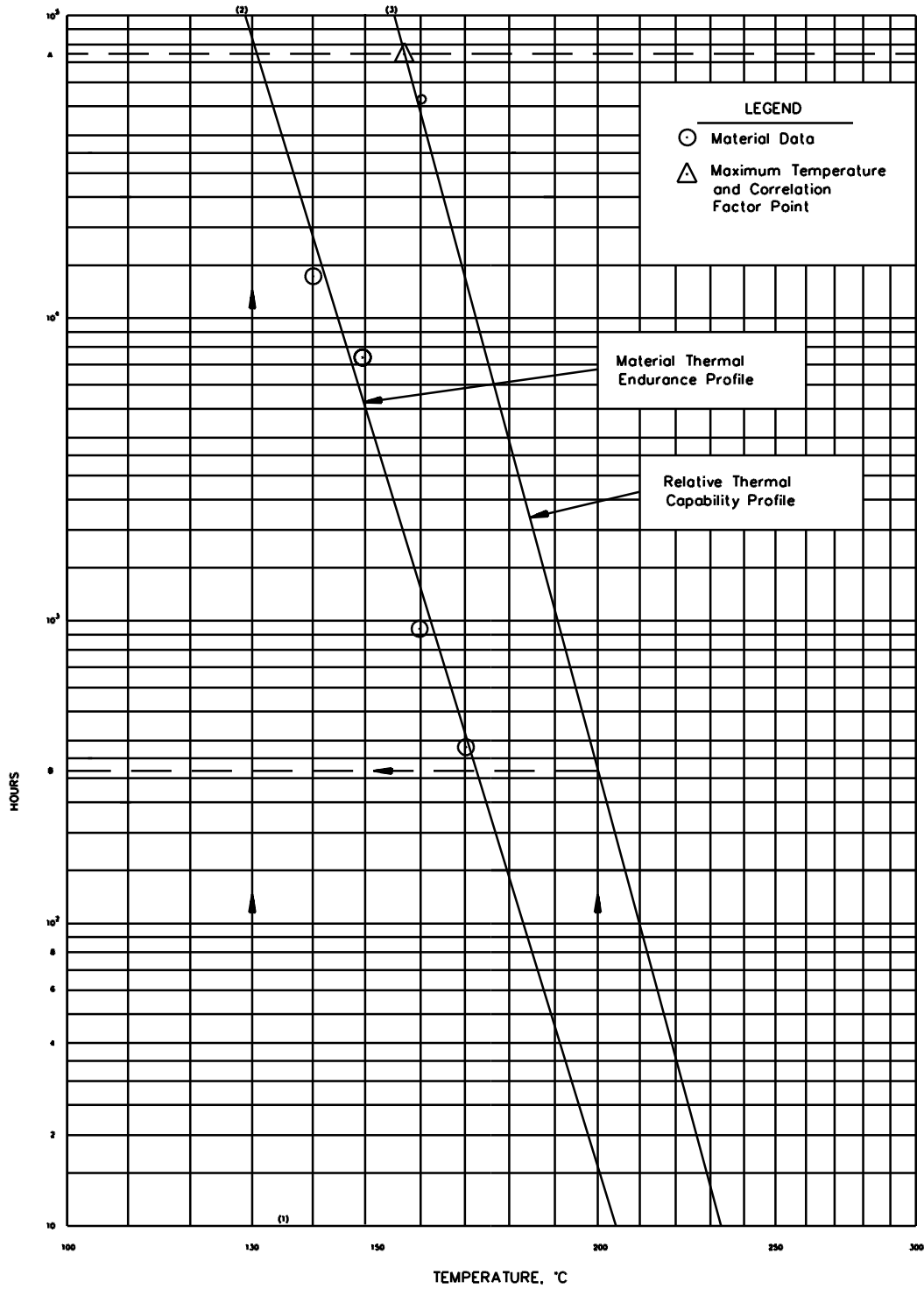

A = 73,969 hours
B = 330 hours

S2004

39 Temperature Excursions Beyond the Maximum Use Temperature

39.1 Electrical products and equipment may be subjected to cyclic or transient temperature peaks during or immediately after intended operation. Short term temperature excursions, above the limits established for the appropriate thermal indices, may be acceptable for specific applications and constructions provided that long term aging information is available for the material (see Relative Thermal Index, Section 36). It may be necessary to use the procedure described in Relative Thermal Capability, Section 37, in order to determine acceptability.

39.2 For example, a heating appliance employing an automatic resettable thermostat will generally experience the greatest temperature excursion during the first few cycles of operation. During subsequent operations, the thermostat will clear the circuit at lower peak temperatures due to an increase in the ambient air temperature.

39.3 For most applications, the product will experience exponential temperature rises and decays where the duration and time constants depend upon the geometry of the product, the thermal masses of the parts, and the magnitude of the heat source.

39.4 In such cases where the Time – Temperature profile is well defined, and can be approximated by a "step" function consisting of a series of (i) constant temperature exposures, each at temperature (T_i) for a fraction of the total cycle time (f_i), then an equivalent continuous use temperature (T_{eq}) can be defined as:

$$T_{eq} = -B / [\ln (\text{Sum on } i \text{ of } (f_i \times \text{Exp}(-B/5_i)))]$$

in which:

T_{eq} is the Equivalent continuous use temperature in °K.

B is the Activation energy constant of the Arrhenius relationship having the form $L = Ae^{B/T}$ (see Relative Thermal Index, Section 36).

$B = - E / R$, where:

E is the activation energy in electron volts

R is the Boltzmann constant, 8.62×10^{-5}

ln is the Natural logarithm

Exp() is the The number e (=2.718284) raised to the power of the exponent ().

The approximating step function shall be constructed to exceed the actual measured characteristic at all points as illustrated in the example indicated in Temperature Excursions Beyond the Maximum Use Temperature, Section 66.

SPECIALIZED APPLICATIONS

40 General – Adhesives

40.1 These requirements cover adhesives used to bond structural parts, where the adhesive is relied upon to maintain the proper functioning of the device with regard to the likelihood of electric shock, fire, and injury to persons.

40.2 These requirements do not cover adhesives used in the manufacture of printed-wiring boards that are covered by the Standard for Printed-Wiring Boards, UL 796.

40.3 Adhesive joints shall comply with the requirements indicated in Function Analysis, Section 41, Program of Investigation, Section 42, and Adhesives – Specialized Applications, Section 69.

41 Function Analysis

41.1 The properties required of the adhesive shall be based upon an analysis of the function or functions of the adhesive in the end-product equipment. Bond strength (or impact strength) shall be considered as a critical property and the evaluation test method shall be selected to relate as closely as possible to the end-product use.

42 Program of Investigation

42.1 End-product evaluation

42.1.1 The strength of an adhesive joint used to position critical parts in electrical equipment shall be capable of withstanding at least four times the maximum force in the as received condition that might be applied to the joint in the end application.

42.2 Effect of environmental conditions

42.2.1 The initial values of the critical properties shall be determined by tests representing as closely as possible actual use conditions. The effect of environmental conditions that might be experienced during normal and reasonably foreseeable abuse of the end product shall be determined. The same evaluation test method shall be used after exposure of the specimens to environmental conditions representative of such use. A critical property shall not be reduced more than 50 percent.

43 Coil Forms

43.1 Materials used in an insulation system shall be evaluated with respect to the requirements for systems of insulating materials – general, UL 1446.

44 Conformal Coatings

44.1 This section and Conformal Coating Test, Section 70 cover requirements for conformal coatings used on printed-wiring boards in electrical equipment where electrical spacings are insufficient between uninsulated live parts of opposite polarity or between such parts and accessible dead metal parts. The coatings are used as a protective covering against environmental conditions and are also used instead of electrical spacings to increase the dielectric voltage withstand capability between lands (traces) on a printed-wiring board.

44.2 The printed-wiring board with conformal coating is to be evaluated in accordance with the Standard for Printed-Wiring Boards, ANSI/UL 796, and is to comply with the requirements indicated in Conformal Coating Test, Section 70, relative to temperature, solder conditions, conductor size, and adhesion to the base material under the conditions encountered in the end-use application.

44.3 Testing is to be conducted on each type of industrial laminate material that is to be considered. Flammability tests are to be conducted in accordance with the requirements for flammability of plastic materials for use in appliances and devices, UL 94, for each type of industrial laminate to be considered. Unclad specimens are to be prepared that contain the minimum and maximum conformal coating thickness, inks and solder resists if employed. The coating shall not degrade the flammability classification of the base material.

Exception No. 1: Testing of ANSI FR-4 is considered representative of ANSI FR-5, G-10, G-11, CEM-1, and CEM-3 materials.

Exception No. 2: Testing of ANSI XXXPC is considered representative of ANSI X, XP, XPC, XX, XXP, XXX, and XXXP materials.

Exception No. 3: Testing of ANSI GPO-2 is considered representative of ANSI GPO-3 material.

Exception No. 4: Flammability tests are not required if the base industrial laminate material is classed HB.

44.3 revised July 15, 1998

METALLIZED PARTS

45 General

45.1 Ductile Coatings, Section 46, Brittle Coatings, Section 47, and Tape Adhesion Test, Section 71A describe requirements to evaluate metallized processes such as those for use in the fabrication of decorative parts or enclosures treated with a conductive surface coating intended for electromagnetic interference (EMI) suppression.

45.1 revised July 7, 1999

45.2 The purpose of these requirements is to evaluate the integrity of the bond between the substrate material and the metallized coating by means of bond strength testing (ductile coatings) or by tape adhesion tests (brittle coatings). The results of these adhesion tests can then be used to judge the acceptability of metallized processes in the end-product where loss of the bond strength might result in electric shock, fire, or both.

45.2 revised July 7, 1999

45.3 These requirements do not cover the additional considerations which must be given a metallized part used as a conducting or bonding member.

45.4 Ductile Coatings, Section 46 and Brittle Coatings, Section 47 describe the performance requirements for metallized parts. Section 46 describes the performance requirements for ductile coatings, such as those found on metallized parts using electroplated ductile copper. Sections 47 and 71A describe the performance requirements for brittle coatings, such as those found on electromagnetic interference (EMI) shields using vacuum-applied foil, arc- or flame-spray coatings, conductive paints, cathode sputtering, and the like.

45.4 revised July 4, 1999

46 Ductile Coatings

46.1 The process shall produce metallized parts that are free of wrinkles, pits, blisters, corrosion, and the like that could result in electric shock, fire, or injury to persons, and have a minimum average unconditioned bond strength between the metal surface and the plastic of 36 g/mm (2 lb/inch) of width. The bond strength is to be determined by tests on copper-plated plaques in accordance with the Standard for Polymeric Materials – Short Term Property Evaluations, UL 746A. Results obtained on 0.05 mm (0.002 inch) ductile copper can be considered representative of lesser thicknesses.

46.2 The process shall produce metallized parts that are capable of withstanding accelerated aging and environmental cycling conditions without a reduction in average bond strength less than 18 g/mm (1 lb/inch) of width. See items 71A.5 (b), (c) and (d) for conditioning requirements.

46.2 revised July 7, 1999

46.3 If the contemplated end use of metallized parts is such that the temperatures to which these parts are to be subjected exceeds the lowest assigned RTI for the applicable critical material properties, the metallized plastic shall be investigated in accordance with the Standard for Polymeric Materials – Long Term Property Evaluations, UL 746B. The primary property for evaluating the thermal degradation shall be bond strength. A reduction of 50 percent of the original bond-strength property shall be considered the end-point criteria.

47 Brittle Coatings

47.1 The metallic coating process shall produce metallized parts that are free of wrinkles, pits, blisters, corrosion, and the like that can result in electric shock, fire, or injury to persons; and have acceptable cohesion and adhesion between the metallized coating and between the metallized coating and the substrate as received and after conditioning. The adhesion strength is to be determined by tests on the flat sections of the test specimens. The tape adhesion test shall be conducted in accordance with the Standard Methods for Measuring Adhesion by Tape Test, ASTM D 3359, Method A or B and Section 71A.

47.1 revised July 7, 1999

47.2 Deleted July 7, 1999

47.3 If the contemplated end use of metallic coated parts is such that the temperatures to which these parts are to be subjected exceeds the lowest assigned RTI for the applicable critical material properties, the metallized plastic shall be investigated in accordance with the Standard for Polymeric Materials – Long Term Property Evaluations, UL 746B. The primary property for evaluating the thermal degradation shall be adhesion by means of the tape adhesion test. After aging, the coatings shall comply with the requirements in 47.1.

47.3 revised July 7, 1999

TEST PERFORMANCE

48 General

48.1 Details

48.1.1 Values of voltage and current are root-mean-square (rms) values, unless otherwise stated.

48.1.2 An appliance having both alternating-current and direct-current ratings is to be tested with the appliance connected to an alternating-current supply and again to a direct-current supply, unless it can be established that one test results in the maximum operating conditions.

48.2 Voltmeters

48.2.1 Unless otherwise indicated, voltage measurements shall be made with a voltmeter having a resistance of 2000 ohms per volt minimum for potentials of 1000 V or less and 20,000 ohms per volt minimum for potentials of more than 1000 V.

48.2.2 The open-circuit voltage measurement used in conjunction with a leakage- or shock-current determination is to be made with a measuring instrument that has an input impedance that does not significantly affect the circuit being measured. In general, a measuring instrument with a minimum input impedance of one megohm is to be used.

48.2.3 A lead, connector, or component that is accessible during intended operation or user-servicing is to be connected for intended operation and is to be arranged in any position likely after user-servicing.

48.3 Cheesecloth indicators

48.3.1 Cheesecloth used for tests shall be bleached cotton cheesecloth, running 26 – 28 m²/kg mass (14 – 15 yd²/lb mass) and having what is known to the trade as a count of 32 by 28.

48.3.2 Tests involving cheesecloth are to be conducted in a room free of drafts.

48.4 Supply-circuit voltage and frequency

48.4.1 All operational tests shall be conducted with the appliance connected to a supply circuit of rated frequency and voltage.

48.4.2 An appliance with one supply circuit frequency rating is to be tested at that frequency. An appliance with a dual frequency rating is to be tested at 60 Hz if 60 Hz is included in the rating and may also be tested at the second frequency if such testing is warranted.

48.4.3 An appliance that can be operated from alternate power supplies, such as dc adapters, car batteries, and the like, is to be tested with those supplies if such testing is considered necessary.

48.4.4 Unless otherwise specified in the individual test method, the standard atmospheric conditions surrounding the specimens or appliance prior to and during the test shall be between 15°C and 35°C (59°F and 95°F) and between 45 percent and 75 percent relative humidity.

49 End-Product Arc Resistance Test

49.1 The current for the arcing test is to be based upon the maximum normal load-current rating that the equipment draws and minimum power factor. The voltage used for the test is to be equal to the available voltage at the live part. The arc is to be established between the live part and any adjacent part where breakdown is likely to occur. The arc is to be used to attempt to ignite materials forming parts of the enclosure or to ignite materials located between the parts of different potential. The arc is to be established by means of a copper or stainless steel conductive probe. The conductive probe is to be used to create arc tracking or a carbon build-up across the surface of the insulating material at the rate of 40 arc separations per minute. (A rate of 30 arc separations per minute may be used if 40 arc separations per minute is not practical.)

50 Abnormal Overload Test

50.1 To determine whether a polymeric material complies with 14.2, separate samples of the equipment or representative sections of the equipment are to be loaded to each indicated overcurrent values for the corresponding test times indicated in Table 50.1. Except as indicated in 50.2, only one sample need be subjected to each of the specified overload tests.

50.2 If a current-carrying conductor within any of the samples of the equipment opens before the minimum test time tabulated in Table 50.1 has elapsed without resulting in ignition, then three samples are to be loaded to a lesser current value, as indicated in 50.6 (b) – (i), for the minimum test time tabulated in Table 50.1 corresponding to the largest overload value that does not result in a current-carrying conductor opening before the minimum test time, or 7 hours.

50.3 For the sequence of tests described in 50.6, if the abnormal overload test continues for 7 hours or the full test time indicated in Table 50.1 without a winding or an acceptable protective device opening, the remaining tests need not be conducted. For example, if the test described in 50.6(a) continues for 7 hours using 110 percent of the overcurrent protective device rating load (namely 33 A for a 30 A overcurrent protective device), 60 minutes using 135 percent of the overcurrent protective device rating load (namely 40.5 A), and 2 minutes using 200 percent of the overcurrent protective device rating load (namely 60 A) the tests described in (b) – (i) need not be conducted.

50.4 The overload current value indicated in 50.6 (b) – (h) is the lesser overload value tabulated in Table 50.1 that resulted in a current-carrying conductor opening before the minimum test time. The base test current value indicated in 50.6 (b) – (i) is the largest overload value tabulated in Table 50.1 that does not result in a current-carrying conductor opening before the minimum test time. If a current-carrying conductor opens before 7 hours within the sample loaded to 110 percent of the overcurrent protective device rating, then the base test current value shall be the rated current of the equipment.

Table 50.1
Abnormal overload test

Overcurrent protective device rating	110-percent current ^a	Minimum test time	
		135-percent current	200-percent current
0 – 30 amperes	7 hours	60 minutes	2 minutes
31 – 60	7	60	4
61 – 100	7	120	6
101 – 200	7	120	8
201 – 400	7	120	10

^a The test may be terminated when the temperatures have stabilized, indicating that ultimate results have already been achieved.

50.5 For the purpose of illustration, consider the following two examples:

Example A:

Given the rated current of the equipment under evaluation is 10 A and the overcurrent protective device rating is 30 A, one sample of the equipment, designated sample 1, is then loaded to 33 amperes for 7 hours, another sample, designated sample 2, is loaded to 40.5 A for 60 minutes and a third sample, designated sample 3, is loaded to 60 A for 2 minutes.

If sample 1 continues for 7 hours and sample 2 continues for 60 minutes without a current-carrying conductor opening, but a current-carrying conductor in sample 3 opens before 2 minutes, then 3 samples of the equipment, designated samples 4, 5 and 6, are subjected to the abnormal overload test for 60 minutes loaded to the base test current (40.5 A) plus 75 percent of the difference between the overload current (60 A) and the base test current (40.5 A), namely 55 A.

Example B:

Given the same information as Example A above except in samples 1, 2 and 3 a current-carrying conductor opens before 7 hours, 60 minutes and 2 minutes respectively, then 3 samples of the equipment, designated samples 4, 5, and 6, are subjected to the abnormal overload test for 7 hours loaded to the base test current (rated current of 10 A) plus 75 percent of the difference between the overload current (33 A) and the base test current (10 A), namely 27.25 A.

50.6 Loading the equipment shall not result in ignition, undue distortion, or melting of the material being evaluated under any of the following conditions:

- a) Loading the equipment to the specified overload values per Table 50.1.
- b) Loading the equipment to a current equal to the base test current plus 75 percent of the difference between the overload current and the base test current.
- c) Loading the equipment to a current equal to the base test current plus 50 percent of the difference between the overload current and the base test current.
- d) Loading the equipment to a current equal to the base test current plus 25 percent of the difference between the overload current and the base test current.
- e) Loading the equipment to a current equal to the base test current plus 20 percent of the difference between the overload current and the base test current.
- f) Loading the equipment to a current equal to the base test current plus 15 percent of the difference between the overload current and the base test current.
- g) Loading the equipment to a current equal to the base test current plus 10 percent of the difference between the overload current and the base test current.
- h) Loading the equipment to a current equal to the base test current plus 5 percent of the difference between the overload current and the base test current.
- i) Loading the equipment to the base test current.

50.7 To determine whether a material complies with the requirement in 50.2, three samples of the complete equipment are to be subjected to each condition described in 50.6 (a) – (i).

50.8 For the loading conditions, a variable resistor is to be connected in series with the equipment. The tests described in 50.6 (a) – (i) are to be continued for the test times indicated in 50.6 and Table 50.1, unless a current-carrying conductor within the equipment or a acceptable protective device opens in a shorter time. In conducting the tests described in 50.6 (b) – (i), the variable resistance load is to be adjusted to the required value as quickly as possible and readjusted, if necessary, 1 minute after application of voltage to the equipment.

50.9 For equipment that is provided with a built-in, acceptable, protective device (as indicated in 14.4) the tests described in 50.6 (a) – (h) are to be concluded if the protective device opens the circuit. If the protective device is of the automatic recycling type, the test is to be continued for the full time indicated in Table 50.1.

50.10 Samples for the abnormal overload tests are to be prepared as follows:

- a) The complete equipment is to be placed on a white tissue paper covered softwood surface.
- b) The equipment is to be connected to a suitable supply circuit, that may use a low voltage current source, fused at not less than 30 A.

50.11 Each abnormal-overload test is to be continued until ignition of the material occurs, the circuit under test burns open, or until the test time indicated in 50.2 and Table 50.1 is achieved.

51 Flammability – 12 mm Flame Test

51.1 Three samples of the complete equipment or three test specimens of the part thereof shall be subjected to this test. Consideration is to be given to leaving in place components and other parts that might influence the performance. The test samples are to be conditioned in a full draft circulating air oven for 7 days at 10°C (18°F) greater than the maximum use temperature but not less than 70°C (158°F) in any case prior to testing, the samples are to be conditioned for a minimum of 4 hours at 23.0 ±2.0°C (73.4 ±3.6°F) and 50 ±5 percent relative humidity. The samples are then to be tested as described in 51.2 – 51.6.

Exception: The test may be conducted on only unconditioned test samples if both of the following conditions are met:

- a) The material does not exhibit a reduction in its flame-resistance properties as a result of long-term thermal aging.*
- b) The thermal-aging program used for such determination included specimens having a thickness equal to or less than the wall thickness of the polymeric part.*

51.2 Three samples of the part are to be subjected to the flame test described in 51.5. In the performance of the test, the equipment is to be supported in its intended operating position in a draft-free location. Consideration is to be given to leaving in place components and other parts that might influence the performance. The flame shall be applied to an inside surface of the sample at a location judged to be likely to become ignited because of its proximity to a source of ignition. For example, motor or transformer windings, brush holders, switch contacts, terminals, connections, and so forth are considered possible sources or ignition. If more than one part is near a source of ignition, each sample shall be tested with the flame applied to a different location.

Exception: The flame may be applied to the outside surface of an enclosure, if the equipment is of the encapsulated type or of such size that the flame cannot be applied inside.

51.2 revised October 16, 2000

51.3 With reference to 51.2, the sections most likely to be ignited should be considered as those adjacent to arcing parts, or other possible sources of ignition.

51.4 The burner to produce the flame consists of a tube at least 35 mm long having an inside diameter of 0.5 ±0.1 mm and an outer diameter not exceeding 0.9 mm. The burner shall not have air ports. The gas supply shall be butane having a purity of at least 95 percent, and a heat content of approximately 122 MJ/m³.

51.5 With the axis of the burner in a vertical position, the gas supply is to be adjusted so that a 12 mm flame is produced. Two 30 second applications of the tip of the flame are to be made to each section of the equipment, selected as indicated in 51.3, with a 1 minute interval between the applications.

51.6 If one sample from a set of three does not comply with 17.1, an additional set of 3 samples shall be tested. All samples from the second set shall comply with 17.1 to be considered acceptable.

52 Flammability – 3/4 Inch Flame Test

52.1 Three samples of the complete equipment or three test specimens of the part thereof shall be subjected to this test. Consideration is to be given to leaving in place components and other parts that might influence the performance. The test samples are to be conditioned in a full draft circulating air oven for 7 days at $10 \pm 1^\circ\text{C}$ or ($18 \pm 2^\circ\text{F}$) greater than the maximum use temperature but not less than 70°C (158°F) in any case prior to testing, the samples are to be conditioned for a minimum of 4 hours at $23.0 \pm 2.0^\circ\text{C}$ ($73.4 \pm 3.6^\circ\text{F}$) and 50 ± 5 percent relative humidity. The samples are then to be tested as described in 52.2 – 52.5.

Exception: The test may be conducted on only three unconditioned test samples if both of the following conditions are met:

- a) The material does not exhibit a reduction in its flame-resistance properties as a result of long-term thermal aging.*
- b) The thermal-aging program used for such determination included specimens having a thickness equal to or less than the wall thickness of the polymeric part.*

52.1 revised March 19, 1997

52.2 Three samples of the part are to be subjected to the flame test described in 52.4. In the performance of the test, the equipment is to be supported in its normal operating position in a draft-free location. Nonpolymeric portions of the part in contact with or fastened to the polymeric portions are not to be removed and, insofar as possible, the internal mechanism of the equipment is to be in place. The flame shall be applied to an inside surface of the sample at a location judged to be likely to become ignited because of its proximity to a source of ignition. For example, motor or transformer windings, brush holders, switch contacts, terminals, connections, and so forth are considered possible sources of ignition. If more than one part is near a source of ignition, each sample shall be tested with the flame applied to a different location.

Exception: The flame may be applied to the outside surface of an enclosure if the equipment is of the encapsulated type or of such size that the flame cannot be applied inside.

52.2 revised October 16, 2000

52.3 With reference to 52.2, the sections most likely to be ignited should be considered as those adjacent to coil windings, splices, open-type switches, or arcing parts.

52.3.1 A laboratory type burner having a tube with a length of 100 ± 10 mm (3.94 ± 0.39 inch) and an inside diameter of 9.5 ± 0.3 mm (0.374 ± 0.012 inch) is to be used. The barrel is not to be equipped with an end attachment, such as a stabilizer. The burner shall be in compliance with ASTM D5025, Specification for a Laboratory Burner Used for Small-Scale Burning Tests on Plastic Materials. Adjust the burner to produce a blue flame 20 ± 1 mm high (3/4 inch nominal). The flame is obtained by adjusting the gas supply and air ports of the burner until a 20 ± 1 mm (3/4 inch nominal) yellow-tipped blue flame is produced. Increase the air supply until the yellow tip just disappears. Measure the height of the flame again and readjust it if necessary. The test flame shall be calibrated in accordance with ASTM D 5207, Standard Practice for Calibration of 20 mm and 125 mm Test Flames for Small-Scale Burning Tests on Plastic Materials at least once a month and when the gas supply is changed, test equipment is replaced, or when data is questioned.

52.3.1 revised July 15, 1998

52.4 Two 30 second applications of the tip of the flame are to be made to each section of the equipment selected as indicated above, with 1 minute intervals between the applications. A supply of technical-grade methane gas (minimum 98 percent pure) is to be used with a regulator and meter for uniform gas flow. The methane gas supply to the burner shall be arranged as in Figure 52.1 and adjusted to produce a gas flow rate of 105 ml/min with a back pressure less than 10 mm of water. See ASTM D 5207. The flow meter shall be a rotameter calibrated in accordance with ASTM D 3195, Practice of Rotameter Calibration with correlation curves appropriate for the gas, or a mass flow meter with ± 2 percent accuracy.

Exception: Natural gas having a heat content of approximately 37 MJ/m^3 (1000 Btu/ft^3) at 23°C (73.4°F) has been found to provide similar results; however, technical grade methane shall be used in case of dispute.

52.4 revised March 19, 1997

52.5 If one sample from a set of three does not comply with 18.1, an additional set of three samples shall be tested. All samples from the second set shall comply with 18.1 to be considered acceptable.

Figure 52.1
Burner supply arrangement

Figure 52.1 added July 17, 1997

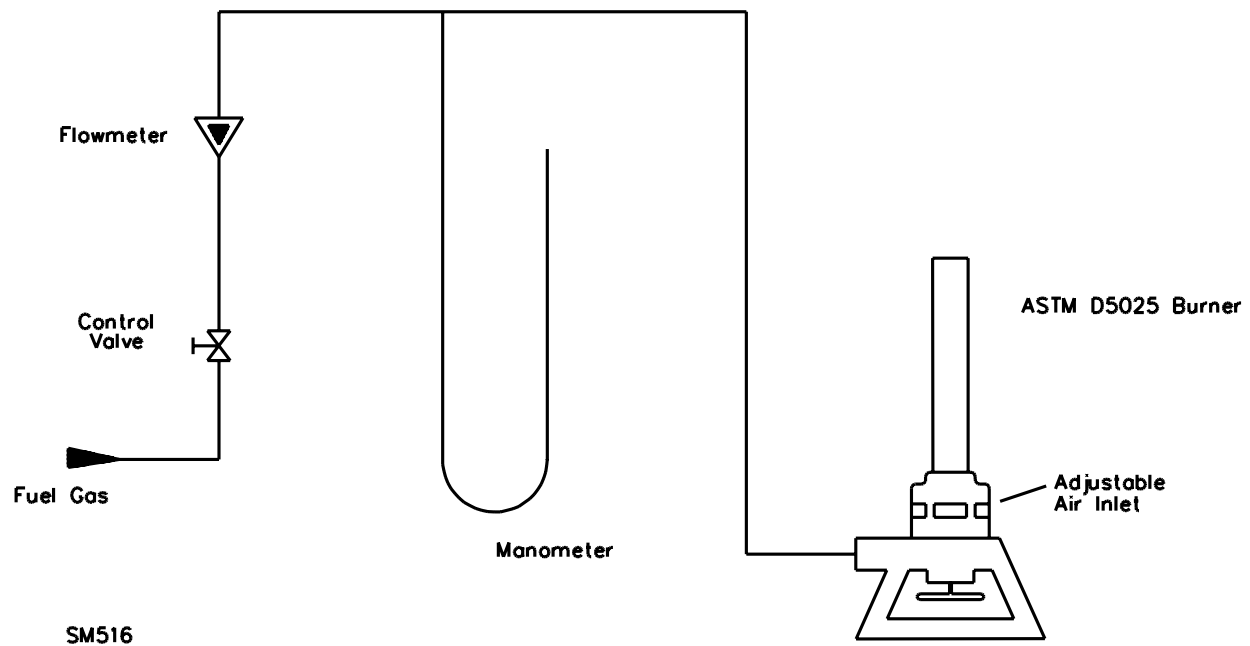

No Text on This Page

53 Flammability – 5 Inch Flame Test

53.1 Three samples of the complete equipment or three test specimens of the part thereof shall be subjected to this test. Consideration is to be given to leaving in place components and other parts that might influence the performance. The test samples are to be conditioned in a full draft circulating air oven for 7 days at 10°C (18°F) greater than the maximum use temperature but not less than 70°C (158°F) in any case. Prior to testing, the samples are to be conditioned for a minimum of 4 hours at 23.0 ±2.0°C (73.4 ±3.6°F) and 50 ±5 percent relative humidity. The flame shall be applied to an inside surface of the sample at a location judged to be likely to become ignited because of its proximity to a source of ignition. If more than one part is near a source of ignition, each sample shall be tested with the flame applied to a different location.

Exception: The test may be conducted on only three unconditioned test samples if both of the following conditions are met:

- a) The material used does not exhibit a reduction in its flame-resistance properties as a result of long-term thermal aging.*
- b) The thermal-aging program used for such determination included specimens having a thickness equal to or less than the wall thickness of the polymeric part.*

53.2 The three test samples are to result in the acceptable performance described in 19.1. If one sample does not comply, the test is to be repeated on a set of three new samples with the flame applied under the same conditions as for the unsuccessful sample. If all the new specimens comply with 19.1 the material is acceptable.

53.3 The laboratory burner, adjustment and calibration are to be identical to that described for the 3/4-inch flame test except:

- 1) The gas flow rate shall be 965 ml/min with a back pressure of 125 ±25 mm water, and
- 2) The flame height shall be adjusted, with the burner vertical in a darkened room, to an overall height of approximately 125 ±10 mm and the height of the inner blue cone to 40 ±2 mm.

53.3 revised March 19, 1997

53.4 When a complete enclosure is used to conduct the flame test, the sample is to be mounted as intended in service, if it does not impair the flame testing, in a draft-free test chamber, enclosure, or laboratory hood. A layer of absorbant 100 percent cotton is to be located 305 mm (12 inch) below the point of application of the test flame. The 127 mm (5 inch) flame is to be applied to any portion of the interior of the part judged as likely to be ignited (by its proximity to live or arcing parts, coils, wiring, and the like) at an angle of approximately 20 degrees in so far as possible from the vertical so that the tip of the blue cone touches the specimen. The test flame is to be applied to three different locations on each of the three samples tested. A supply of technical-grade methane gas is to be used with a regulator and meter for uniform gas flow.

Exception No. 1: The flame may be applied to the outside of an enclosure if the equipment is of the encapsulated type or of such size that the flame cannot be applied inside.

Exception No. 2: Natural gas having a heat content of approximately 37 MJ/m³ (1000 Btu/ft³) at 23°C has been found to provide similar results and may be used.

53.4 revised March 19, 1997

53.5 The flame is to be applied for 5 seconds and removed for 5 seconds. The operation is to be repeated until the specimen has been subjected to five applications of the test flame.

54 Enclosure Flammability – 746-5VS Test

54.1 Apparatus

54.1.1 The apparatus employed is to consist of the following:

- a) A test chamber, enclosure, or laboratory hood free of induced or forced draft during tests.
- b) Laboratory Burner – A Bunsen or Tirrill burner having a tube with a length of 100 ± 10 mm (3.94 ± 0.39 inch) and an inside diameter of 9.5 ± 0.3 mm (0.374 ± 0.012 inch). The tube shall not be equipped with end attachments, such as a stabilizer.
- c) Ring Stand – A ring stand with clamps or the equivalent, adjustable for vertical positioning of specimens.
- d) Gas Supply – A supply of technical grade methane gas with regulator and meter for uniform gas flow. Natural gas having a heat content of approximately 37 MJ/m^3 (1000 Btu/ft^3) has been found to provide similar results. However, technical grade methane gas is to be used in case of question.
- e) Mounting Block – A block capable of positioning the burner at an angle of 20 degrees from the vertical.
- f) Stopwatch or other timing device.
- g) Desiccator containing anhydrous calcium chloride.
- h) Conditioning room or chamber capable of being maintained at $23 \pm 2^\circ\text{C}$ ($73 \pm 3.6^\circ\text{F}$) and a relative humidity of 50 ± 5 percent.
- i) Conditioning Ovens – A full draft circulating-air oven capable of being maintained at $70 \pm 1^\circ\text{C}$ ($158 \pm 1.5^\circ\text{F}$).
- j) A supply of dry absorbent surgical cotton.

54.1.2 Test plaques approximately 152×152 mm (6×6 inch) are to be tested in the minimum and maximum thicknesses covering the thickness range to be considered, with the minimum coating thickness. Plaques tested by this method are limited to a maximum thickness of 12.7 mm (0.50 inch). Plaques in intermediate thicknesses are also to be provided and may be tested if the results obtained on the minimum and/or maximum thickness indicate a need. Intermediate thicknesses should not exceed increments of 3.17 mm (0.125 inch).

54.2 Plaque conditioning

54.2.1 Sets of five test plaques are to be conditioned as follows:

- a) Sets are to be conditioned for at least 48 hours at a temperature of $23 \pm 2^\circ\text{C}$ ($73.4 \pm 3.6^\circ\text{F}$) and a relative humidity of 50 ± 5 percent prior to testing.
- b) Sets are to be conditioned in a circulating-air oven for 168 hours at $70 \pm 1^\circ\text{C}$ ($158 \pm 1.8^\circ\text{F}$) and then cooled in a desiccator over anhydrous calcium chloride for at least 4 hours at room temperature prior to testing.

54.2.2 The burning test is to be conducted in a chamber, enclosure, or laboratory hood that is free of induced or forced draft. An enclosed laboratory hood, with a heat resistant glass window, and an exhaust fan for removing the products of combustion after the test, is recommended.

54.2.3 The burner is to be placed remote from the specimen, ignited, and in a darkened room, adjusted so that when the burner is in a vertical position, the overall height of the flame is 127 mm (5 inches), and the height of the inner blue cone is 38 mm (1-1/2 inches).

54.2.4 The test plaque is to be supported by a clamp on the ring stand in the vertical position, so that the plaque is 305 mm (12 inches) above a horizontal layer of dry absorbent surgical cotton. The burner is to be supported on the inclined plane of a mounting block so that the burner tube may be positioned at 20 degrees from the vertical.

54.2.5 The flame is then to be applied to the center of the coated side of the plaque at an angle of 20 degrees from the vertical, so that the tip of the blue cone touches the surface of the plaque. See Figure 54.1.

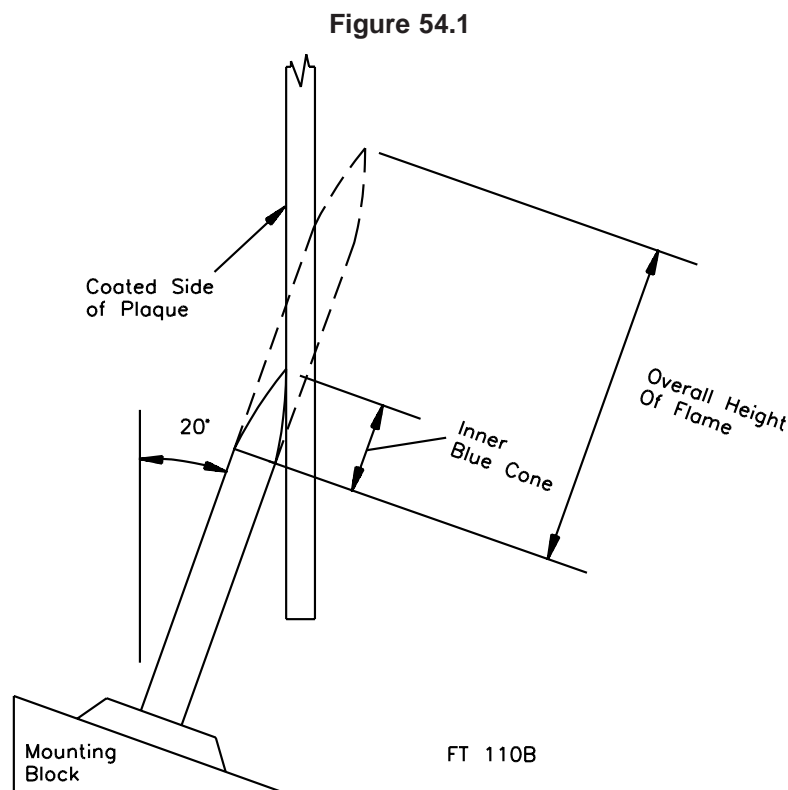

54.2.6 The flame is to be applied for 60 seconds and removed.

54.2.7 After the removal of the test flame, the following are to be observed and recorded:

- a) Duration of flaming plus glowing.
- b) Whether or not plaques dripped flaming particles which ignite cotton.
- c) Whether or not the flame burned through the plaque.

55 Flame-Retardant Coatings Test

55.1 Specimen conditioning

55.1.1 Effects of temperature

55.1.1.1 Forty coated specimens are to be conditioned in full-draft circulating-air ovens, twenty in each oven, operating at $80.0 \pm 2.0^{\circ}\text{C}$ ($17.6 \pm 3.6^{\circ}\text{F}$) for 1500 hours, and $90.0 \pm 2.0^{\circ}\text{C}$ ($194.0 \pm 3.6^{\circ}\text{F}$) for 800 hours. Following the specified conditioning periods, the specimens are to be removed and conditioned for 40 hours at $23.0 \pm 2.0^{\circ}\text{C}$ ($73.4 \pm 3.6^{\circ}\text{F}$) and 50 ± 5 percent relative humidity prior to testing. The conditioned specimens shall comply with the requirements in 22.2.

55.1.1.1 revised May 20, 1996

55.1.2 Effects of humidity

55.1.2.1 Five flammability and five adhesion specimens are to be tested after conditioning at 108 ± 12 hours at $35.0 \pm 3.0^{\circ}\text{C}$ ($95.0 \pm 5.4^{\circ}\text{F}$) and 90 ± 5 percent relative humidity. The specimens are to be tested immediately following the humidity exposure and shall comply with 22.2.

55.1.2.1 revised May 20, 1996

55.1.3 Effects of environmental cycling

55.1.3.1 Five flammability and five adhesion specimens, after being subjected to the environmental cycling described in 55.1.3.2 shall comply with the requirements in 22.2.

55.1.3.1 revised May 20, 1996

55.1.3.2 The environmental cycling is to consist of three cycles of:

- a) 48 hours in a full-draft circulating air oven operating at $70.0 \pm 1.0^{\circ}\text{C}$ ($158.0 \pm 1.8^{\circ}\text{F}$).
- b) 48 hours at $35.0 \pm 2.0^{\circ}\text{C}$ ($95.0 \pm 3.6^{\circ}\text{F}$) at 90 ± 5 percent relative humidity.
- c) 8 hours at $0.0 \pm 2.0^{\circ}\text{C}$ ($32.0 \pm 3.6^{\circ}\text{F}$).
- d) 4 hours of vibration at room temperature (approximately 25°C or 75°F), consisting of simple harmonic oscillating motion at right angles to the longitudinal plane of the specimen. The simple harmonic oscillating motion is to be 55 ± 5 hertz with the peak deflection adjusted to result in a 1.5g acceleration.
- e) 60 hours at $35.0 \pm 2.0^{\circ}\text{C}$ ($95.0 \pm 3.6^{\circ}\text{F}$) and 90 ± 5 percent relative humidity.

55.1.3.2 revised May 20, 1996

55.1.3.3 The specimens shall be brought to and tested at room temperature after exposure.

55.1.3.3 revised May 20, 1996

55.1.4 Test methods

55.1.4.1 Test methods concerning enclosure flammability testing are described in the requirements for flammability of plastic materials for parts in devices and appliances, UL 94, and in Sections 18 – 20 of this standard.

55.1.4.2 Test methods concerning flexural strength and impact properties are described in the Standard for Polymeric Materials – Short Term Property Evaluations, UL 746A, and in 55.1.4.3.

55.1.4.3 The test method concerning the effects of flexing on adhesion is described as follows. A set of five adhesion specimens, each 127 by 12.7 mm (5 by 1/2 inch), in the minimum enclosure thickness, are to be horizontally mounted and rigidly clamped 12.5 mm (1/2 inch) from one end. A load is to be applied at a rate of 12.3 – 50.8 mm per min (0.5 – 2.0 inches per min) 115 mm (4-1/2 inches) from the clamped end. The load is to be applied to cause a 25.4 mm (1 inch) vertical deflection upward, a 50.8 mm (2 inch) vertical deflection downward, and a 25.4 mm (1 inch) vertical deflection upward, completing a cycle. Each test specimen is to be flexed for five complete cycles.

55.1.5 Surface resistivity

55.1.5.1 The surface resistivity of the flame-retardant coating on the enclosure material when tested as described in 55.1.5.2 and 55.1.5.3, shall be at least 1 megohm.

55.1.5.2 Three specimens, each 100 by 100 mm (4 by 4 inches) shall be subjected to both of the following:

- a) 40 hours at $23.0 \pm 2.0^{\circ}\text{C}$ ($73.4 \pm 3.6^{\circ}\text{F}$) and 50 ± 5 percent relative humidity.
- b) 168 hours at $35.0 \pm 3.0^{\circ}\text{C}$ ($95.0 \pm 5.4^{\circ}\text{F}$) and 90 ± 5 percent relative humidity. See also the Standard for Polymeric Materials – Short Term Property Evaluations, UL 746A.

55.1.5.3 Specimens are to be tested immediately after each humidity exposure. If the resistivity is not essentially the same for each of the conditionings, the conditioning described in 55.1.5.2(b) shall be continued for a longer period of time to demonstrate that the asymptotic resistivity is at least 1 megohm.

55.1.6 Other considerations

55.1.6.1 Analytical tests are to be performed to determine the general composition of the material. The analytical tests may include but are not limited to:

- a) Percent Solids at 105°C (216°F) – Weighed samples (approximately 5 grams) of the coating in porcelain evaporating dishes are to be heated to constant weight at $105.0 \pm 1.0^\circ\text{C}$ ($221.0 \pm 1.8^\circ\text{F}$) in an electric oven, cooled in a desiccator, and weighed. The percent solids can be calculated from the weight of the original samples and the weight of the residue after heating.
- b) Percent Ash (Dry-Basis) – The dried specimens of the coating remaining from the percent-solids test are to be used to determine the ash content as described in the Standard for Polymeric Materials – Short Term Property Evaluations, UL 746A. The dry-basis percent ash can be calculated from the weight of the dry sample after heating at $105.0 \pm 1.0^\circ\text{C}$ ($221.0 \pm 1.8^\circ\text{F}$) and the weight of the residue after ignition.
- c) Weight per Gallon – The weight per gallon of the coating is to be determined by means of a Baltimore weight-per-gallon cup.
- d) Qualitative Infrared Analysis – An infrared spectrum of the material is to be obtained as outlined in the Standard for Polymeric Materials – Short Term Property Evaluations, UL 746A.
- e) Qualitative X-Ray Analysis – The specimen is to be analyzed by X-ray for the presence of known fire-retardant elements (chlorine, bromine, phosphorus, and antimony).
- f) Percent Chlorine (Dry-Basis) – Specimens are to be spread on a watch glass and dried to constant weight at $105.0 \pm 1.0^\circ\text{C}$ ($221.0 \pm 1.8^\circ\text{F}$) in an electric oven. The entire specimen shall be peeled off and used for the determination. The dried specimens (approximately 0.3 gram) shall be heated in a heat-resistant glass tube with powdered calcium hydroxide and the resulting calcium chloride determined by the Volhard method.
- g) Percent Phosphorus (Dry-Basis) – Weighed specimens (approximately 0.1 gram) of the coating are to be digested with concentrated nitric acid for 24 hours minimum at $150.0 \pm 1.0^\circ\text{C}$ ($302.0 \pm 1.8^\circ\text{F}$). An acid digestion bomb is to be used in the digestion procedure. The digested sample is to be diluted to a known volume and the percent phosphorus determined colorimetrically by the molybdenum blue method using a colorimeter to measure color density.

56 Crushing Resistance Test

56.1 Three samples of equipment are to be supported on the mounting side by a fixed rigid supporting surface, in the position that is recommended by the manufacturer. Crushing force is to be applied to the exposed surfaces of the enclosure. The compression force is to be applied by flat surfaces each 102 by 254 mm (4 by 10 inches). Each force applicator is to exert 45.4 kg (100 lb) on the sample. As many applicators are to be applied as the sample can accommodate, up to a maximum of 8, based upon an arrangement of applicators as indicated in Figure 56.1.

Figure 56.1
Location of applicators for crush-resistance test

Figure 56.1 revised July 15, 1998

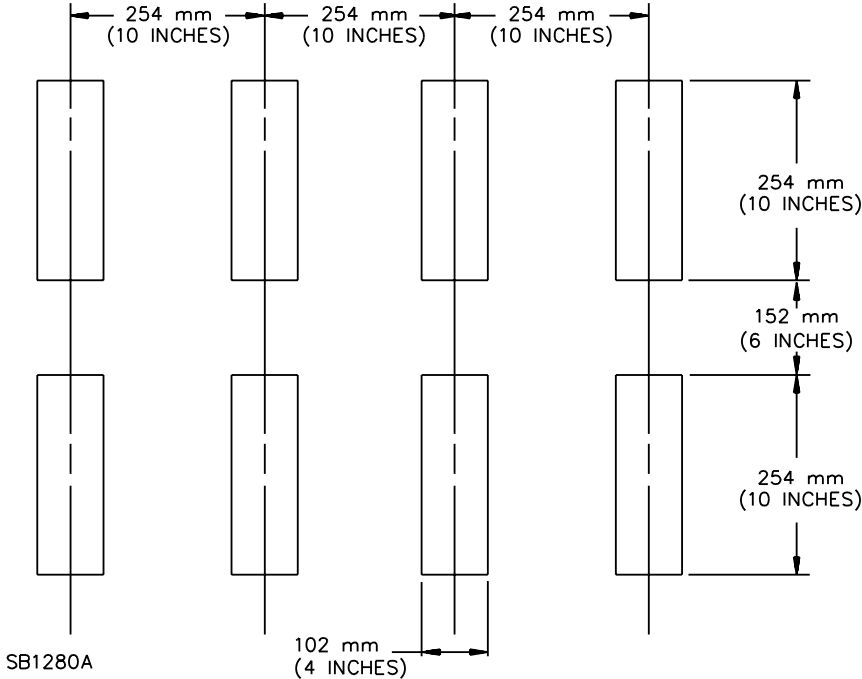

57 Resistance to Impact Test

57.1 Hand-supported equipment shall be subjected to the drop impact test described in (a) and (b).

a) Each of three samples of the equipment is to be dropped through 0.91 m (3 ft) to strike a hardwood surface in the position most likely to produce adverse results. The hardwood surface is to consist of a layer of nominal 25 mm (1 inch) tongue-and-groove oak flooring (actual size 18 by 57 mm or 3/4 by 2-1/4 inch mounted on two layers of nominal 19 mm (3/4 inch) plywood. The assembly is to rest on a concrete floor or an equivalent nonresilient floor during the test.

b) Each sample is to be dropped three times so that, in each drop, the sample strikes the surface in a position different from those in the other two drops. Three samples shall be employed for the test; however, if the manufacturer so elects, fewer samples may be used in accordance with Figure 57.1. The overall performance is acceptable upon completion of any one of the procedures represented in that figure. If any sample does not comply on its first series of three drops, the results of the test are unacceptable.

57.2 Permanently wired equipment, or floor-supported equipment or equipment not likely to be dropped during intended use – such as counter-supported equipment – shall be subjected to the ball impact test described in 57.3.

57.3 Each of three samples of the appliance shall be subjected to a single impact of the value shown in Table 57.1 for the applicable equipment type, on any surface that can be exposed to a blow during intended use. This impact is to be produced by dropping a steel sphere, 50.8 mm (2 inches) in diameter, and weighing 0.535 kg (1.18 lb) mass from the height necessary to produce the specified impact as shown in Figure 57.2. The steel sphere shall strike the surface in a location different from those in the other two impacts. For surfaces other than the top on an enclosure, either the sample could be supported on the side and subjected to the ball impact mentioned above, or the steel sphere is to be suspended by a cord and swung as a pendulum, dropping through the vertical distance necessary to cause it to strike the surface with the specified impact as shown in Figure 57.2. Three samples shall be employed for the tests in the equipment restrained mode. However, if the manufacturer so elects, fewer samples may be used in accordance with Figure 57.1. The overall performance is acceptable upon completion of any one of the sequences represented in Figure 57.1.

57.4 In lieu of conducting the room temperature test described in paragraph 57.3, three specimens of equipment intended for outdoor use shall be cooled to a temperature of minus 35.0 ±2.0°C (minus 31.0 ±3.6°F) and maintained at this temperature for 3 hours. Three specimens of indoor equipment intended for use in locations where the temperature may be less than actual room conditions, such as unheated warehouses or garages, – approximately 23°C (73°F) – shall be cooled to a temperature of 0.0 ±2.0°C (32.0 ±3.6°F) and maintained at this temperature for 3 hours. While the unit is still cold, the specimens shall be subjected to the impact described in 57.1 or 57.3 as applicable. The conditions for acceptable results are as indicated in 24.1.

57.4 revised May 20, 1996

Figure 57.1
Procedures for impact tests

Each series consists of three drops or one ball impact on each sample as applicable

Figure 57.1 revised July 15, 1998

Series Number	Sample Number											
	1	2	3	1	2	3	1	2	3	1	2	3
1	↓ A	N	N	↓ A	N	N	↓ A	N	N	↓ A	N	N
2	↓ A	N	N	↓ A	N	N	↓ U	↘ A	N	↓ U	↘ A	N
3	↓ A	N	N	↓ U	↘ A	N	↓ A	N		↓ U	↘ A	

Arrows indicate sequence of test procedure

A – Acceptable results from drop

U – Unacceptable results from drop

N – No test necessary

SA1162

No Text on This Page

Table 57.1
Ball impact requirements for equipment joules (foot-pounds)

Easily moved equipment		All other equipment
Counter-supported^{a,b}	Floor-supported^c	
1.02 (0.75)	6.8 (5.0)	6.8 (5.0)

^a Individual product requirements may require a higher level of impact resistance.

^b Counter-supported equipment is that which is typically supported by a counter, table, or bench during the performance of its intended electrically operated functions. Reference is to be made to the specific equipment's Use and Care Literature in establishing the intended electrically operated functions of the equipment.

^c Floor-supported equipment is that which is typically supported by the floor during the performance of its intended electrically operated functions. Reference is to be made to the specific equipment's Use and Care Literature in establishing the intended electrically operated functions of the equipment.

Figure 57.2
Ball impact tests

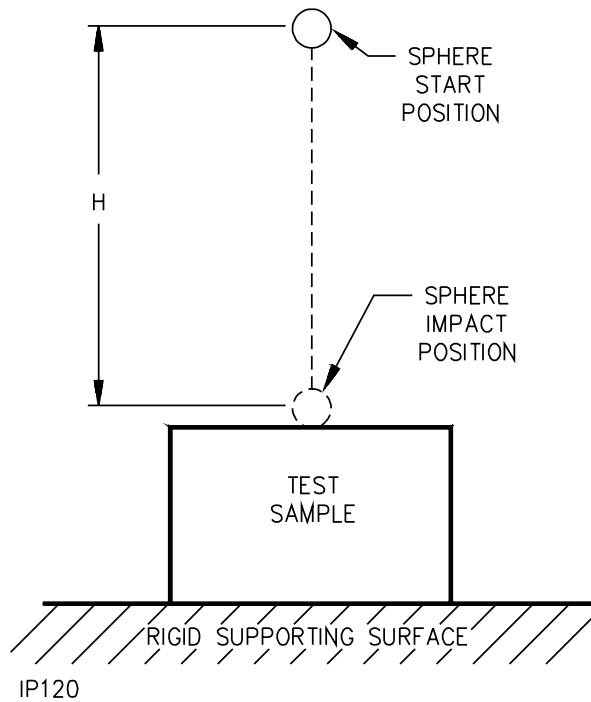

IP120

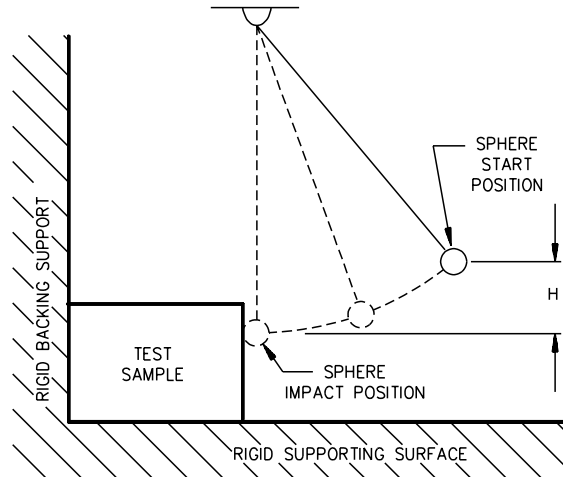

IP 160

- 1 – H in Figure 57.2 indicates the vertical distance the sphere must travel to produce the desired impact.
- 2 – For the ball-pendulum impact test the sphere is to contact the test sample when the string is in the vertical position as shown.
- 3 – The backing surface is to consist of 19 mm (3/4 inch) plywood over rigid surface of concrete. An equivalent nonresilient backing surface may be used.

58 Ultraviolet Light Exposure Test

58.1 Apparatus

58.1.1 Specimens are to be exposed to ultraviolet light and water spray by using either of the following apparatus:

- a) Twin enclosed carbon-arc lamp in accordance with the Standard Practice for Exposing Nonmetallic Materials in Accelerated Test Devices That Use Laboratory Light Sources, ASTM G151, and the Standard Practice for Operating Enclosed Carbon Arc Light Apparatus for Exposure of Nonmetallic Materials, ASTM G153. The spectral power distribution of the enclosed carbon-arc shall conform to the requirements in ASTM G153 for enclosed carbon-arc lamp with borosilicate glass globes. A programmed cycle of 20 minutes consisting of a 17-minute light exposure and a 3-minute exposure to water spray with light shall be used. The apparatus shall operate with a black-panel temperature of $63 \pm 3^{\circ}\text{C}$ ($145 \pm 5^{\circ}\text{F}$), or
- b) Xenon-arc lamp in accordance with the Standard Practice for Exposing Nonmetallic Materials in Accelerated Test Devices That Use Laboratory Light Sources, ASTM G151, and the Standard Practice for Operating Xenon Arc Light Apparatus for Exposure of Nonmetallic Materials, ASTM G155. The spectral power distribution of the xenon lamp shall conform to the requirement in Table 1 in ASTM G155 for a xenon lamp with daylight filters. A programmed cycle of 120 minutes consisting of a 102-minute light exposure and an 18-minute exposure to water spray with light shall be used. The apparatus shall operate with a spectral irradiance of $0.35 \text{ W/m}^2 \text{ nm}$ at 340 nm and a black-panel temperature of $63 \pm 3^{\circ}\text{C}$ ($145.4 \pm 5.4^{\circ}\text{F}$).

Exception: Indoor enclosures that are subjected to UV radiation sources (such as, high intensity discharge lamps), may be conditioned without exposure to water.

58.1.1 revised October 16, 2000

58.2 Method

58.2.1 The specimens as indicated in the Standard for Polymeric Materials – Short Term Property Evaluations, UL 746A, are to be mounted vertically on the inside of the cylinder in the ultraviolet-light apparatus, with the width of the specimens facing the arcs, and so that they do not touch each other.

Exception No. 1: For flexural strength specimens the ultraviolet-exposed side is to be in contact with the two points when using the three-point loading method.

Exception No. 2: Izod impact specimens are to be notched prior to UV conditioning with the direction of UV exposure towards the notch.

58.2.2 Two sets of specimens are to be exposed. For twin enclosed carbon-arc, one set is to be exposed for a total of 360 hours and the second set for a total of 720 hours. For xenon-arc, one set is to be exposed for a total of 500 hours and the second set for a total of 1000 hours. After the test exposure, the specimens are to be removed from the test apparatus, examined for signs of deterioration such as crazing or cracking, and retained under conditions of ambient room temperature and atmospheric pressure for not less than 16, nor more than 96 hours, before being subjected to flammability and physical tests. For comparative purposes, specimens that have not been exposed to ultraviolet light and water are to be subjected to these tests at the same time that the final exposed specimens are tested.

58.2.3 The flammability classification of base samples described in the requirements for tests for flammability of plastic materials for parts in devices and appliances, UL 94, of the material in the thinnest part thickness under consideration, shall not be reduced as a result of the UV conditioning. Except as noted in 58.2.6, the average physical property values after 720 hours of twin enclosed carbon-arc exposure in accordance with ASTM G151 and G153 or 1000 hours xenon-arc exposure in accordance with ASTM G151 and G155, weatherometer conditioning shall not be less than 70 percent of the unconditioned value when the standardized small-scale physical tests shown in Table 58.1 are performed as described in the Standard for Polymeric Materials – Short Term Property Evaluations, UL 746A.

58.2.3 revised October 16, 2000

Table 58.1
Physical-property test methods

Table 58.1 revised October 16, 2000

Physical-property consideration	Material test method
Functional support	Tensile strength or Flexural strength ^a
Impact resistance	Tensile impact, Izod impact, or Charpy impact
^a The ultraviolet-exposed side is to be in contact with the two loading points when using the three-point loading method.	

58.2.4 Tensile or flexural strength tests are to be conducted on specimens no thicker than the corresponding application. The results of Tensile, Charpy or Izod Impact testing of standard specimens in the nominal 3 mm thickness, can be considered representative of the testing of a reduced thickness not less than 0.8 mm, provided the non-impact testing of the reduced thickness complies with the requirements of Table 26.1.

58.2.4 revised October 16, 2000

58.2.5 If a material is to be considered in a range of colors, specimens representing these ranges are also to be provided. Specimens in the natural (if used in this color) and in the most heavily pigmented light and dark colors are to be provided and considered representative of the color range, if the test results are essentially the same. An additional set of specimens is to be provided in the heaviest organic pigment loading, unless the most heavily pigmented light and dark colors include the highest organic pigment level. When certain color pigments (for example, red, yellow, or the like) are known to have particularly critical effects, they are also to be provided.

58.2.6 Where it is not practical to conduct tests using the standardized small-scale impact-test specimens, the procedure of 58.2.7 – 58.2.11 and the impact equipment of Figures 58.1 and 58.2 may be used on representative sections of the enclosure as an alternative for tests conducted on tensile or izod impact specimens.

58.2.7 Referring to Figures 58.1 and 58.2, the equipment for impact is to consist of the following: a cast aluminum base, two steel-rod impact weights weighing 0.91 kg (2 lb) and 1.82 kg (4 lb); a hardened-steel round-nose impactor weighing 3.64 kg (8 lb) and with a radius of 8 mm (0.312 inch); a slotted guide tube 1.0 m (39.3 inches) in length, where the impact weights slide and also having inch-pound (joule) graduations in 0.23 J (2 inch-lb) increments. A bracket fixes the tube in vertical position by attaching it to the base and also holds the hand knob, that is a pivot-arm alignment for the impactor approximately 50 mm (2 inches) under the tube. This instrument is to be mounted firmly to a rigid table or bench. The specimen support plate as shown in Figure 58.2 is to be removed, leaving the specimen support-diameter of 31.8 mm (1.25 inch).

58.2.8 Each determination of impact resistance is to be made using 20 specimens. One at a time the specimens are to be placed so that they are centered over the opening in the specimen support. All specimens for a given material must be of the same thickness. The impactor foot is to be lowered to come in contact with the top surface of the specimen. To conduct the test, the weight, either 0.91 or 1.82 kg (2 or 4 lb), as needed, is to be raised to the height to give the desired impact value and released so that it drops on the impactor. The sample is then to be examined for a crack, break, or split appearing on the side opposite the contact area. If the first sample results in a crack, split, or break, the next is to be impacted at a level one increment lower. This increment may be 0.5 to 2.0 times the estimated standard deviation(s) described in 58.2.10. If the sample passes this test, the next sample is to be tested at an equal increment higher than the first sample.

58.2.9 Data is to be analyzed using the Up-and-Down Design (Staircase) Method described in the National Bureau of Standards Handbook 91, "Experimental Statistics", to estimate the mean value before and after the UV exposure. Reference to Figure 58.3 provides sample calculations and data record. The result of the test procedure shows a variation of impact values for the 20 samples that alternately increases and decreases as shown. The summaries at the end of the data table show the number that resulted in unacceptable results (n_x), the number that resulted in acceptable results (n_o), a constant (i) that varies from 0 for the lowest impact where unacceptable results were obtained to 1, 2, 3, and so forth for the next higher values that are used, the number of events that occurred at each test value (n_i), a value for the product of the preceding two columns ($i n_i$), and a value for the product of this column and the i -column ($i^2 n_i$) in the remaining calculations, the totals for all columns except the i -column are used and are designated as (N_x), (N_o), (N), (A), (B).

58.2.10 The Estimated Standard Deviation shall be calculated to determine if the chosen increments are within the proper range. An increment equal to the standard deviation is the most desirable. This deviation is determined from the formula:

$$S = 1.6 \times d [B/N - (A/N)^2] + 0.47 d$$

in which:

d is the increment of height in mm.

58.2.11 The Mean Failure Height (h) is determined using the formula:

$$h = h_0 + d (A/N) \pm 0.5d$$

in which:

h^0 is the lowest height that impact failure occurred.

The Mean Failure Energy (MFE) is determined from the formula:

$$\text{MFE} = hwf$$

in which:

w is the value of the weight in kilograms

f is 9.80665×10^{-3} a factor for conversion to joules.

The value of MFE before and after UV exposure is used to determine compliance with 58.2.5 or 58.2.7, as appropriate.

Figure 58.1
Impact tester

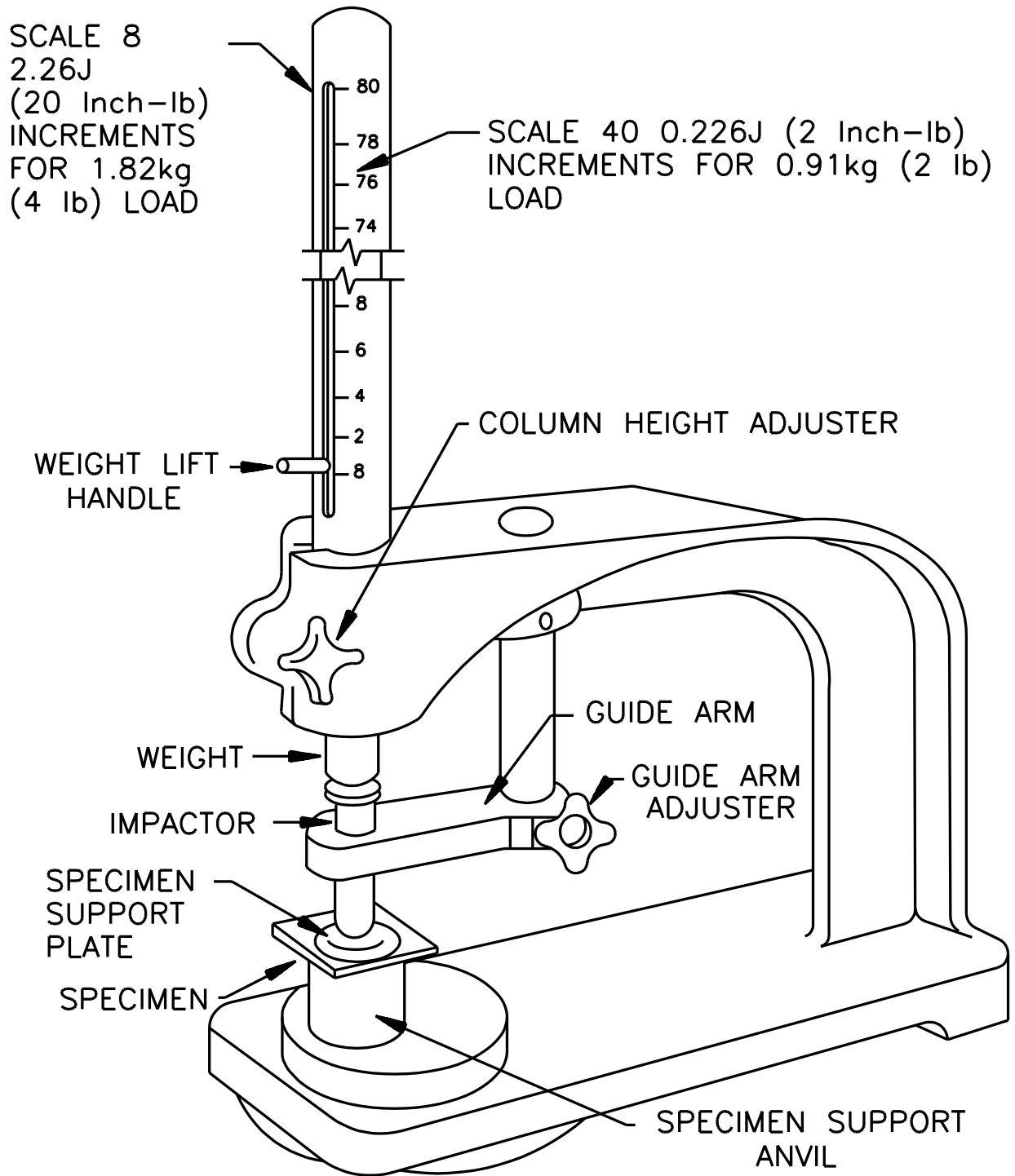

SB1935A

Figure 58.2
Impact tester parts in contact with specimen

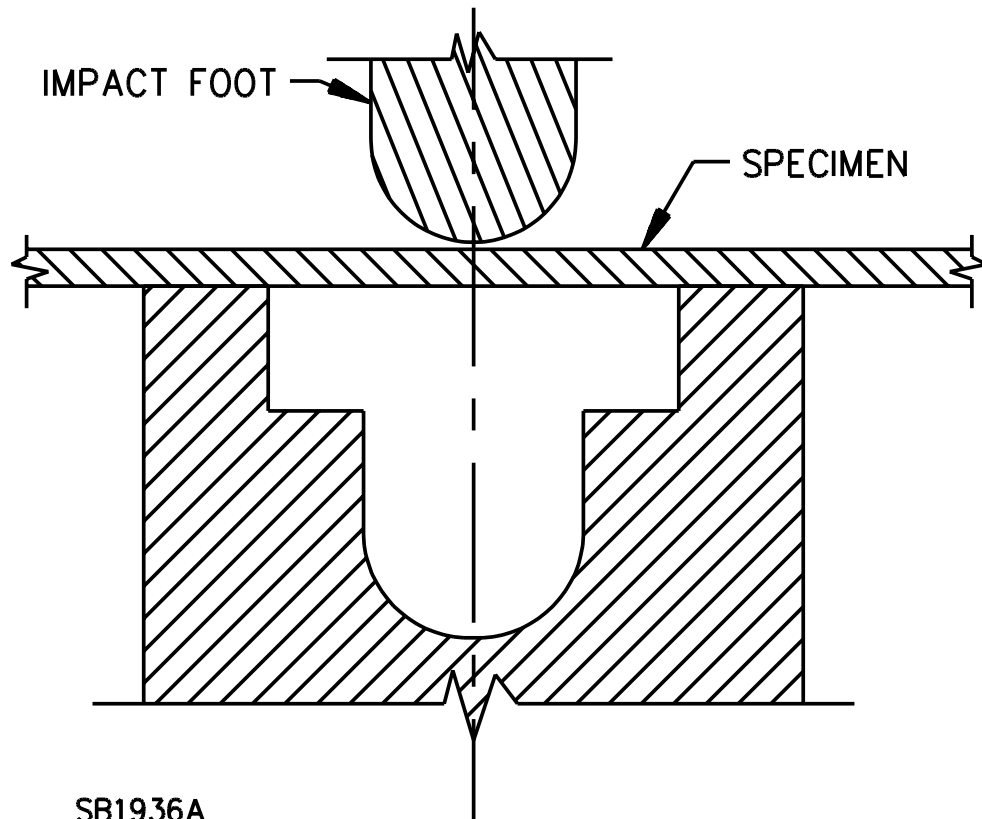
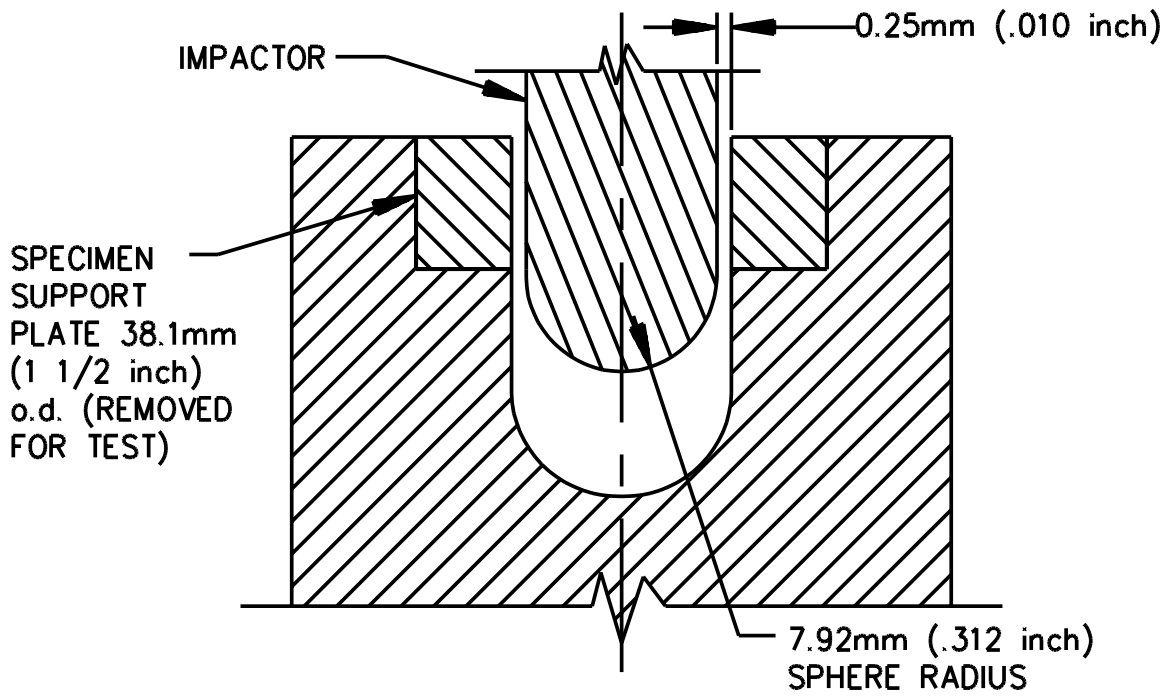

Figure 58.3
Sample calculations

Drop height mm	Outcome of test (X – failure; 0 – nonfailure)																				n _x	n _o	i	n _i	i n _i	i ² n _i	
	1	2	3	4	5	6	7	8	9	10	11	12	13	14	15	16	17	18	19	20							
900						X															1	0	2	1	2	4	
800					0		X		X				X		X						4	1	1	4	4	4	
700		X		0				0		X		0		0		X			X		0	4	5	0	4	0	0
600	0		0								0							0		0	0	5					
Totals																						9	11		9	6	8
																						(N _x)	(N _o)		(N)	(A)	(B)

$$h_o = 700; N_x = 9; d = 100$$

$$h = h_o d (A/N) - 0.5d$$

$$= 700 + 100 (6/9) - 0.5 (100)$$

$$= 717 \text{ mm}$$

$$s = 1.6d [B/N - (A/N)^2] + 0.0668d$$

$$= 1.6 \times 100 \times [2/9 - (6/9)^2] + 0.0668 \times 100$$

$$= 77.8 \text{ mm}$$

$$\text{MFE} = h w f w = 0.907 K g$$

$$= 717 \times 0.907 \times 9.80665 \times 10^{-3}$$

$$= 6.37 \text{ J}$$

59 Water Exposure and Immersion Test

59.1 Using standard test procedures, property values for the material are to be determined both before and after the conditioning described below:

- a) Specimens of the material shall be immersed in distilled or deionized water at $70.0 \pm 1.0^\circ\text{C}$ ($158.0 \pm 1.8^\circ\text{F}$) for 7 days. A complete change of water is to be made on each of the first 5 days. Following the water conditioning, those specimens that are to be subjected to physical-property tests are to be immersed in distilled or deionized water at $23.0 \pm 2.0^\circ\text{C}$ ($73.4 \pm 3.6^\circ\text{F}$) for 1/2 hour immediately prior to testing. Following the immersions, those specimens to be subjected to flammability tests are to be conditioned in air at $23.0 \pm 2.0^\circ\text{C}$ ($73.4 \pm 3.6^\circ\text{F}$) and 50 \pm 5 percent relative humidity for 2 weeks. Physical property tests conducted on the 3.2 mm (1/8 inch) thick specimens are considered representative of other thicknesses, down to 1.6 mm (1/16 inch).

Exception: For materials classed 5VA or 5VB or materials that are evaluated by Enclosure Flammability – 5 inch Flame Test, Section 53, the specimens shall be immersed in distilled or deionized water at $82 \pm 1^\circ\text{C}$ ($180 \pm 1.8^\circ\text{F}$) rather than $70 \pm 1^\circ\text{C}$.

59.1 revised July 17, 1997

59.2 The following properties shall be included in the evaluation (See Table 58.1):

- a) For Functional Support, either
 - 1) Tensile Strength, or
 - 2) Flexural Strength
- b) For Impact Resistance, either
 - 1) Tensile Impact, or
 - 2) Izod Impact, or
 - 3) Charpy Impact.
- c) Flammability, as described in the requirements for tests for flammability of plastic materials for parts in devices and appliances, UL 94. See 58.2.3 – 58.2.7, and Table 58.1.

59.2 revised July 15, 1998

59.3 Tensile Strength Tests conducted on 3.2 mm (1/8 inch nominal) or 4.0 mm thick specimens are considered representative of other thicknesses, down to 0.8 mm (1/32 inch).

59.3 revised July 17, 1997

60 Abnormal Operation Test

60.1 The equipment is to be operated under the conditions of abnormal operation, that are appropriate for the product, such as stalled-rotor operation, air inlet blocked, and operation with live parts short-circuited. During the test, the equipment is to rest on white tissue paper on a softwood surface. A single layer of cheesecloth is to be draped over the entire equipment and the equipment is to be operated continuously until the ultimate results have been determined. In most cases, continuous operation for 7 hours may be necessary to obtain the ultimate results. Only one of the simulated abnormal conditions described above is to be imposed at one time. A new sample may be used to evaluate any or all conditions of abnormal use.

61 Severe Conditions Test

61.1 The equipment is to be operated in accordance with the conditions indicated below. During the test, the equipment is to rest on white tissue paper on a softwood surface. A single layer of cheesecloth is to be draped over the entire equipment and the equipment is to be operated as described in (a) – (c) until ultimate results have been determined. The maximum temperature of the enclosure material, during the conditioning shall be recorded unless burnout occurs.

- a) Unless the equipment is provided with a momentary-contact line switch (one that requires constant pressure to hold it in the on position) and no means for locking the switch in the on position, a sample of the equipment shall be operated at no-load and rated voltage (see 63.1 for 7 hours).
- b) A sample of the equipment shall be operated at 106 percent of rated voltage (see 63.1 under the same conditions of use as for the normal-temperature test for 7 hours).
- c) A sample of the equipment shall be operated at 94 percent of rated voltage (see 63.1) under the same conditions of use as for the normal-temperature test for 7 hours.

Exception: A manufacturer may elect to use the same sample for each conditioning provided that acceptable results are obtained.

61.2 For each of the conditioning methods mentioned in 61.1, an overload protective device provided with the equipment is to be bypassed.

Exception: User-serviceable or resettable overcurrent or overtemperature protectors can be maintained in the circuit during the conduct of the test provided that they have been shown by a separate investigation to reliably clear the circuit at the voltage, current, and power-factor levels involved.

62 Mold Stress-Relief Distortion Test

62.1 One sample of the equipment shall be conditioned in accordance with either (a) or (b) below:

- a) One sample of the complete equipment (in the case of an enclosure) or the part under consideration, is to be placed in a full draft circulating air oven maintained at a uniform temperature at least 10°C (18°F) higher than the maximum temperature of the material measured under actual operating conditions, but not less than 70°C (158°F) in any case. The sample is to remain in the oven for 7 hours. After its careful removal from the oven and return to room temperature, the sample is to be investigated for compliance with 30.1.
- b) One sample of the complete equipment is to be placed in a test cell. The circulation of air within the cell is to simulate actual room conditions. The air temperature within the cell, as measured at the supporting surface of the equipment, is to be maintained at 60°C (140°F). The equipment is to be operated in the same way as for the temperature test except for equipment that is not loaded or is not continuously loaded during the normal temperature test. Such equipment, although unloaded, shall be connected to 106 percent or 94 percent of normal rated voltage, whichever results in higher temperatures. In any case, the equipment is to be operated for 7 hours. After its careful removal from the test cell, the sample is to be investigated for compliance with 30.1.

62.2 One sample of the complete equipment, or enclosure thereof, is to be placed in a full draft circulating air oven maintained at a uniform temperature at least 10°C (18°F) higher than the maximum temperature of the material measured during the equipment conditioning described in 61.1, but not less than 70°C (158°F) in any case. The sample is to remain in the oven for 7 hours. After its careful removal from the oven and return to room temperature, the sample is to be investigated for compliance with 30.1.

Exception: If the equipment electrically burns-out as a result of the conditioning of 61.1, the oven test temperature is to be 10°C (18°F) higher than the maximum enclosure temperature measured under actual operating conditions or the highest temperature obtained under the conditions of 61.1 without burnout.

62A Ball Pressure Test on End-Product

Section 62A added July 15, 1998

62A.1 This test method determines the value of temperature at which a standard force applied through a spherical shape, causes a defined value of penetration. The test method is described in IEC 695-10-2.

62A.2 Enclosures and other external parts of insulating material (other than those of ceramic material) are to be tested, as indicated. The test is to be conducted at several temperatures so that the specific temperature can be determined at which the diameter of the impression, after the specified conditioning, is 2.0 ± 0.1 mm (0.079 ± 0.004 inch).

63 Input to Motors Test

63.1 Unless otherwise indicated or if primary-circuit adjustments are not provided, the test is to be conducted with the equipment connected to a supply circuit of maximum rated voltage and rated frequency except that, if the marked voltage is in the 105 – 120 V range, the potential of the supply circuit is to be 120 V and, if the marked voltage is in the 210 – 240 V range, the potential of the supply circuit is to be 240 V. If primary-circuit adjustments are provided, they are to be set for the minimum voltage in the 105 – 120 V range, or in the 210 – 240 V range, and the potential of the supply circuit is to be 120 V, or 240 V, whichever is applicable. See 31.1.

64 Relative Thermal Capability

64.1 Computation of the Relative Thermal Capability (RTC) (see Section 37) requires definition of the following:

- a) RTI (from the UL 746B procedure)
- b) Life Equation Parameter (B)
- c) Excess Performance Factor (P)
- d) Property-Time Degradation characteristics for one or more aging temperatures

The factor, P, associated with a critical property is the ratio of the actual performance level measured in the finished part to the minimum normally acceptable level. For example, consider an enclosure material where the minimum level of impact strength is defined by the end-product standard to be 6.75 J (5 ft-lb). Testing reveals that, due to increased material thickness or other strengthening design features, the enclosure will consistently survive impacts of up to 13.5 J (10 ft-lb). Therefore, the excess performance factor, $P = 10 / 5 = 2$.

64.2 A reduced end-of-life performance (percent) is calculated as $f = 50/P$. Property-Time degradation characteristics at one or more aging temperatures, from the original aging program for the RTI, are then used to determine the time t_1 required for the property to degrade to the reduced "f" percent level. The ratio $F = t_1/t_0$ is calculated, where t_0 is the end-of-life time corresponding to 50 percent degradation. If data is available at more than one temperature, then the minimum resulting F is to be used for the RTC calculation.

64.3 If a material has an RTI of 130°C, where impact properties are essential in some minimum thickness equal to less than the application, the life equation parameter, $B = 3423$, and the minimum value of F determined from Property-Time degradation characteristics is 1.5, then the RTC is computed as follows. (See Temperature Considerations – Illustrative Example, Section 67).

$$\text{RTC} = [1 / (\text{RTI} + 273.16) - (\log F) / B]^{-1} - 273.16$$

$$\text{RTC} = [1 / (130 + 273.16) - (\log 1.5)/3423]^{-1} - 273.16$$

$$\text{RTC} = (0.0024804 - 0.00005144)^{-1} - 273.16$$

$$\text{RTC} = 138.5^\circ\text{C}$$

65 Relative Thermal Capability (Alternate)

65.1 Except as indicated below, samples of the part in question may be aged for 1000 hours at the corresponding part aging (see 38.6) temperature determined from the generated relative thermal capability profile line and the part aging temperature shall not exceed the aging temperature used in the original material thermal aging investigation. At the completion of the aging, the samples are to be cooled to room temperature and then subjected to the end-product tests that stress the functional usage of the material. Polymeric parts that are subjected to any type of long-term loading (for example, bending, compression, or tensile loading) shall comply with the creep analysis described in the Standard for Polymeric Materials – Short Term Property Evaluations, UL 746A.

Exception No. 1: A shorter or longer time at a higher or lower part aging temperature, respectively, may be employed if agreeable to all concerned; however, a period of time not less than 300 hours is to be used.

Exception No. 2: The part aging temperature may exceed the aging temperatures used in the original thermal aging investigation for the material providing that thermal analysis techniques, such as Differential Scanning Calorimetry (DSC) and Thermogravimetry (TG), show the absence of transitions in the temperature region beyond the material aging temperature that affects the Activation Energy of the material.

65.2 Samples of the part may be aged by either of the two methods indicated below:

- a) The samples of the product are to be connected to a supply circuit and the input voltage is to be adjusted so that the hot spot aging temperature is achieved on the part in question. It may be necessary to bypass safety circuits or to conduct the test in a room or test chamber with an elevated ambient temperature in order to achieve the aging temperature of the part. If the test terminates before the aging time is reached (heating element opens), the test is to be repeated on another sample at a lower temperature and for a longer time selected from the generated thermal endurance profile line (Figure 38.1).
- b) In lieu of the operational test described above, samples of the part may be aged in a circulating-air oven for the required aging time.

66 Temperature Excursions Beyond the Maximum Use Temperature

66.1 For the purpose of illustration consider the following example (Figure 66.1). A steam flatiron contains a leaf type thermostat that regulates temperatures on the sole plate. After three minutes of operation thermal equilibrium is achieved and the thermostat functions in a cyclic fashion in accordance with the measured time-temperature characteristic (Figure 66.1). During the cycle, the highest temperature measured was 180°C (356°F) and the lowest temperature measured was 130°C (266°F). The phenolic thermostat material was subjected to long term thermal aging tests (Relative Thermal Index, Section 36), and relative thermal indices of 170°C (338°F) for all properties have been assigned. The activation energy constant of the Arrhenius relationship ($L = A \times \text{Exp}(B/T)$ for the mechanical without impact and electrical properties has been determined as: $B = 16425.3$. Since the thermostat is located within the appliance enclosure, the mechanical with impact relative thermal index is not considered critical to the application.

66.2 A graphical "step" function is constructed and superimposed to approximate, but always exceed, the actual measured data curve. The temperatures and corresponding fractions of cycle time are then easily obtained from the step function. (Table 66.1)

66.3 Substituting this information into 66.4 equation will yield a continuous use temperature for the thermostat material of 162.12°C (323.82°F).

66.4 A more precise mathematical solution for (T_{eq}) when the temperature is defined continuously as $[T(t)]$ over a time interval (t_{1-2}) is given by the expression:

$$T_{eq} = B / \ln \left[\left(1 / (t_2 - t_1) \right) \int_{t_2}^{t_1} \text{Exp} (-B/T (t)) dt \right]$$

66.5 Since the equivalent continuous use temperature 162.12°C (323.82°F) is less than the assigned relative thermal index (170°C (338°F)), the phenolic material is considered acceptable for use in this thermostat application.

Figure 66.1
Periodic time-temperature characteristics

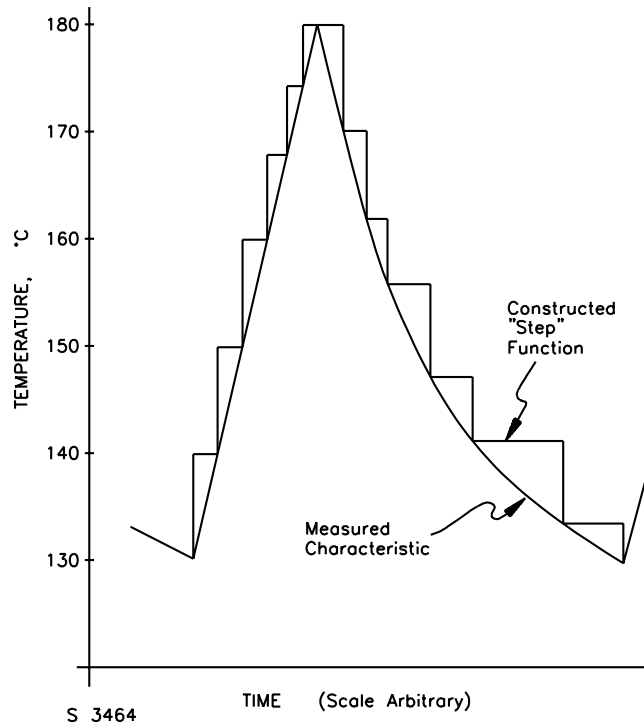

Table 66.1
Periodic time-temperature data

Fraction of cycle time	Temperature degrees C
.05	140
.05	150
.05	160
.05	168
.05	174
.10	180
.05	170
.05	162
.10	156
.10	147.2
.20	141.2
.15	134

67 Temperature Considerations – Illustrative Example

67.1 For the purpose of illustration, refer to Relative Thermal Capability, Section 37, and consider the following example. The enclosure of a cord connected household-use hair dryer, that contains uninsulated live parts, is exposed to a maximum intended use temperature of 137.0°C (278.6°F). The polybutylene terephthalate (PBTP) material used has been assigned a mechanical relative thermal index for impact properties of 130°C (266°F). The electrical and mechanical without impact relative thermal index of 140°C (284°F) has been assigned and was based upon thermal aging data generated at 200, 190, 180 and 170°C. Differential Scanning Calorimetry (DSC) and Thermogravimetry (TG) information is not available for the material.

67.2 The material would not be acceptable using the requirements for the functional-use thermal indices, since the part temperature is 137°C (278.6°F) and the allowable temperature for an attended, intermittent duty, cord connected household appliance enclosure is a maximum of 80°C (176°F).

67.3 The material would not be acceptable using the requirements for the Generic Thermal Indices, since the part temperature is 137°C (278.6°F) and the allowable generic temperature for a PBTP material is a maximum of 75°C (167°F).

67.4 The material would not be acceptable using the requirements for the Relative Thermal Indices, since the part temperature is 137°C (278.6°F) and the specific material's relative thermal index for impact properties is 130°C (266°F).

67.5 The material would be acceptable when used as an enclosure operating at 137°C (278.6°F) for a specific hair dryer model providing that it complies with the requirements for the Relative Thermal Capability (Section 37).

67.6 For this application, it has been judged that electrical (prevention of dielectric breakdown and excessive leakage current), mechanical without impact (functional support of electrical conductors and supporting members), mechanical with impact (for prevention of accessibility to live parts and for continued maintenance of electrical spacings) and retention of flammability characteristics are required enclosure properties for the satisfactory functioning of the part in the application. For this material, the impact property has the highest rate of degradation (lowest relative thermal index) and would therefore be most critical in the application.

67.7 The following data is a summary of the long term heat aging test results on the impact property of the material.

Aging temperature		Time to 50 percent degradation, hours
0°C	0°F	
180	356	2010
170	338	3360
160	320	4530
150	302	7170

A relative thermal index for impact of 130°C (266°F) was assigned to the PBTP material corresponding to a 18,132 hour correlation factor (life).

Using the procedures described in Polymeric Materials – Long Term Property Evaluation, UL 746B, linear regression analysis on the material data resulted in the relationship:

$$\log_{10} (\text{hours}) = A + B / (^\circ\text{C} + 273.16)$$

in which:

A is -4.232

B is 3423

67.8 The minimum acceptable impact resistance as defined by the end-product standard is that the hair dryer must survive a 3 foot drop. Tests reveal that the enclosure will consistently survive a drop from 6 feet. The excess performance factor, P, is therefore $P = 6/3 = 2$, and the reduced end-of-life performance (percent) is $f = 50/2 = 25$ percent. From existing Property-Time degradation characteristics (See Figure 67.1), the minimum ratio $F = t_1/t_0$ determined for one or more temperatures is $F = 1500 / 1000 = 1.5$, and the computed RTC = 138.5°C (281.3°F) (Relative Thermal Capability, Section 64).

Figure 67.1
Property degradation characteristic curve

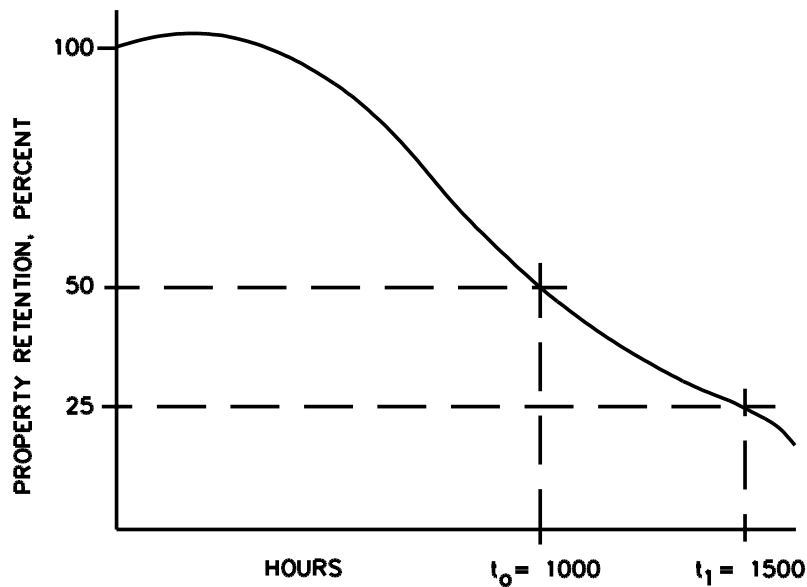

S3552

68 Temperature Considerations – Illustrative Example (Alternate RTC)

68.1 For the purpose of illustration, refer to Relative Thermal Capability (Alternate), Section 38, and consider the following example. The enclosure of a cord connected household-use hair dryer, that contains uninsulated live parts, is exposed to a maximum intended use temperature of 154.0°C (309.2°F). The polybutylene terephthalate (PBTP) material used has been assigned a mechanical relative thermal index for impact properties of 130°C (266°F). The electrical and mechanical without impact relative thermal index of 140°C (284°F) has been assigned and was based upon thermal aging data generated at 200, 190, 180 and 170°C (392, 374, 356, and 338°F). Differential Scanning Calorimetry (DSC) and Thermogravimetry (TG) information is not available for the material.

68.2 The material would not be acceptable using the requirements for the functional-use thermal indices, since the part temperature is 154°C (309.2°F) and the allowable temperature for an attended, intermittent duty, cord connected household appliance enclosure is a maximum of 80°C (176°F).

68.3 The material would not be acceptable using the requirements for the Generic Thermal Indices, since the part temperature is 154°C (309.2°F) and the allowable generic temperature for a PBTP material is a maximum of 75°C (167°F).

68.4 The material would not be acceptable using the requirements for the Relative Thermal Indices, since the part temperature is 154°C (309°F) and the specific material's relative thermal index for impact properties is 130°C (266°F).

68.5 The material would be acceptable when used as an enclosure operating at 154°C (309.2°F) for a specific hair dryer model providing that it complies with the requirements for the Relative Thermal Capability (Alternate), (Section 38).

68.6 For this application, it has been judged that electrical (prevention of dielectric breakdown and excessive leakage current), mechanical without impact (functional support of electrical conductors and supporting members), mechanical with impact (for prevention of accessibility to live parts and for continued maintenance of electrical spacings) and retention of flammability characteristics are required enclosure properties for the satisfactory functioning of the part in the application. For this material, the impact property has the highest rate of degradation (lowest relative thermal index) and would therefore be most critical in the application.

68.7 The following data is a summary of the long term heat aging test results on the impact property of the material.

Aging temperature°C	Time to 50% degradation, hours
180	390
170	848
150	7651
140	14286

A relative thermal index for impact of 130°C was assigned to the PBTP material corresponding to a 73,969 hour correlation factor (life), Line A of Figure 38.1.

Using the procedures described in Polymeric Materials – Long Term Property Evaluations, UL 746B, linear regression analysis on the material data resulted in the relationship:

$$t = Ae^{B/T}, \text{ or}$$

$$\log_{10}(t) = A_1 + \frac{B}{T} \log_{10}e = A_1 + \frac{B_1}{T}$$

in which:

A1 is the log10 (A) = -20.7519297

B1 is B log10e = 10329.35299

T is the absolute temperature, °K (°C + 273.16)

log10 (t) is the logarithm to the base 10 of time in hours.

68.8 The equation for determining the relative thermal capability is obtained by substituting the known maximum application temperature (154°C) and correlation time (73,969 hours). Therefore, the equation for the relative thermal capability for the impact may be expressed as:

$$\log_{10}(73,969) = A_2 + \frac{10329.35299}{154 + 273.16}$$

$$\text{Therefore, } A_2 = -19.31241151$$

$$\text{Hence, } \log_{10}(t) = -19.31241151 + \frac{10329.35299}{^{\circ}\text{C} + 273.16}$$

Substituting the 1000 hour time from 65.1 into this equation yields an oven aging temperature for the part of 190°C (374°F). However, 65.1 will permit a maximum aging temperature of 200°C (392°F), since the electrical and mechanical, without impact, relative thermal indices were determined using data obtained at the highest material aging temperature of 200°C (392°F). Substituting 200°C into the formula will yield a part aging time of 330 hours, line B of Figure 38.1. The part aging temperature of 200°C for 330 hours complies with the minimum 300 hour exposure time (as specified in Exception No. 1 of 65.1).

68.9 Three samples of the product having its safety circuits bypassed, are to be connected to a supply circuit and the input voltage is to be adjusted so that the aging temperature is achieved on the part in question.

68.10 After the 330 hour exposure at 200°C (392°F), the samples would be cooled to room temperature, and then dropped from a 0.91 m (3 foot) height onto a hard wood surface as described in Resistance to Impact Test, Section 57. The samples would then be subjected to dielectric withstand and flammability test as appropriate for the product. Acceptable results would be required if the material is to be considered acceptable for use at temperatures up to 154°C (309.2°F) in this particular application.

69 Adhesives – Specialized Applications

69.1 General

69.1.1 Unless otherwise specified, all testing shall be conducted in a standard laboratory atmosphere at $23.0 \pm 2.0^{\circ}\text{C}$ ($73.4 \pm 3.6^{\circ}\text{F}$) and 50 ± 5 percent relative humidity.

69.1.2 Specimens shall be of the type described in the Standard for Polymeric Materials – Short Term Property Evaluations, UL 746A. Specimen preparations shall be in accordance with the manufacturer's specification for fabrication. Surface preparation shall remove all contaminating substances (mold releases on polymeric surfaces; paint, rust, oxide films, oil, and dust from metal surfaces). Freshly cleaned surfaces shall be protected by a primer if the adhesive cannot be applied immediately. The adhesive can be applied by spray, brush, knife, or film. The temperature and pressure application during bonding shall be in accordance with the adhesive manufacturer's specifications.

No Text on This Page

69.2 As-received test

69.2.1 For each primary property to be evaluated, 20 specimens shall be conditioned for 40 hours at 23.0 \pm 2.0°C (73.0 \pm 3.6°F) and a relative humidity of 50 \pm 5 percent prior to testing.

69.2.2 The specimens are to be subjected to applicable tests to determine the value of the critical properties in the as-received condition. In the case of bond-strength evaluation, specimens that break at an obvious flaw remote from the adhesive line shall be discarded and a retest made. The average value of the property is to be computed. This value is to be used for comparison with values of the same property after the environmental conditioning described in 69.1.1 – 69.5.1.

69.3 Effect of temperature

69.3.1 For each primary property to be evaluated, ten specimens shall be conditioned for 1000 hours at the oven temperature taken from the respective thermal-endurance-profile line in Figure 69.1, where the temperature index T is the measured normal operating temperature of the adhesive, but not less than 60°C (140°F).

Exception No. 1: The effect-of-temperature test need not be conducted on joints bonded by fusion techniques, such as solvent or ultrasonic welding, and the like.

Exception No. 2: On the same thermal-endurance-profile line in Figure 69.1, a shorter or longer time at a higher or lower temperature respectively may be employed if agreeable to all concerned, but a period no less than 300 hours is to be used.

69.3.2 After the conditioning, the specimens shall be brought to and tested at room temperature to determine the critical property values. The average conditioned value for each property is to be at least 50 percent of the unconditioned value.

Figure 69.1
Conditioning time versus oven temperature for temperature index of adhesives

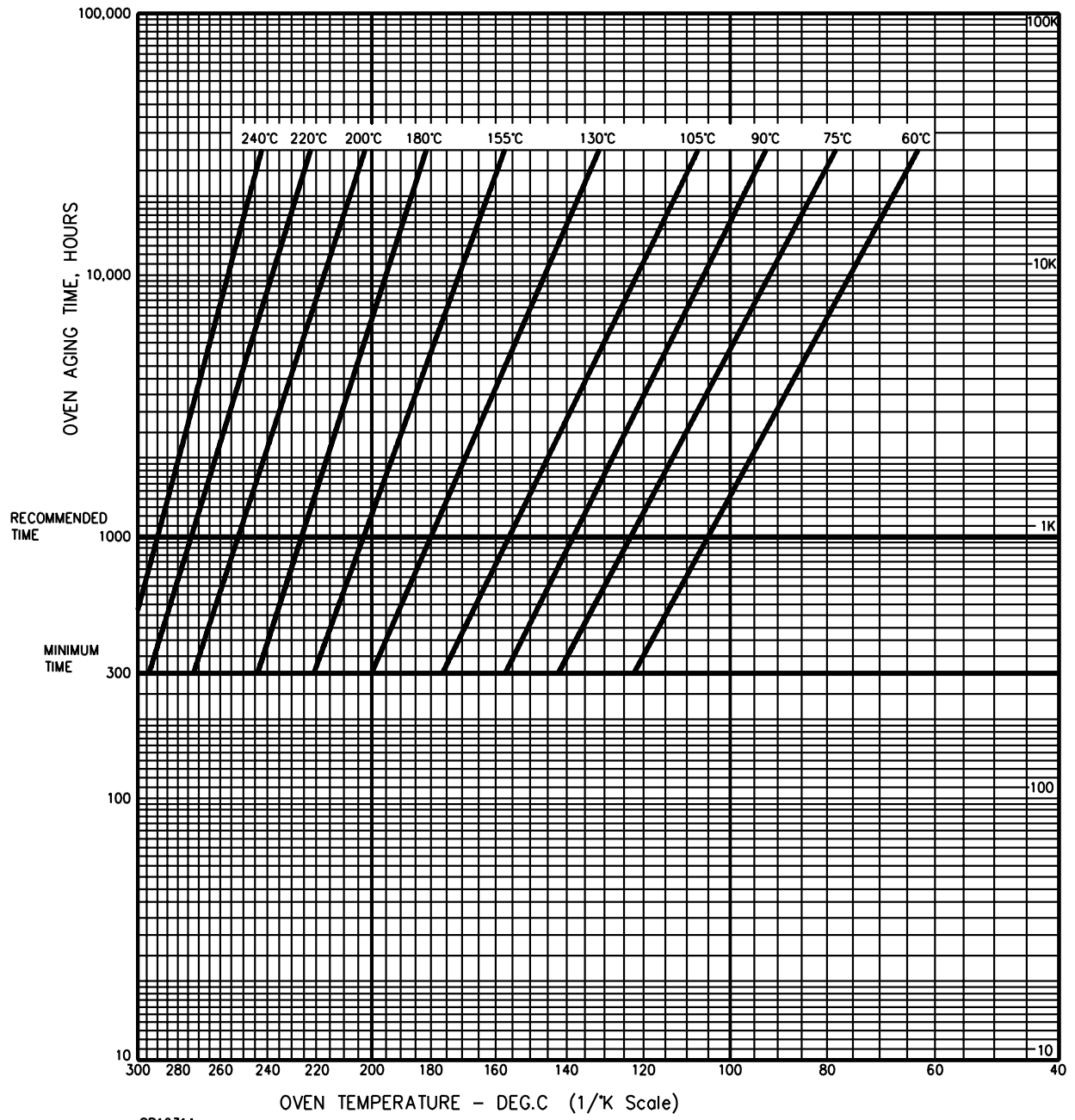

69.4 Effect of humidity

69.4.1 For each primary property to be evaluated, ten specimens shall be conditioned for 7 days at 95 – 100 percent relative humidity at $60.0 \pm 1.0^\circ\text{C}$ ($140.0 \pm 1.8^\circ\text{F}$).

Exception: The effect-of-humidity test need not be conducted on joints bonded by fusion techniques, such as solvent or ultrasonic welding, and the like.

69.4.2 After the conditioning, the specimens shall be brought to and tested at room temperature to determine the critical property values. The average conditioned value for each critical property is to be at least 50 percent of the unconditioned value.

69.5 Effect of cold

69.5.1 There shall be no visual signs of cracking or chipping of the bond between the two adhered parts of the specimens after conditioning for 24 hours at $\text{minus } 35.0 \pm 1.0^\circ\text{C}$ ($\text{minus } 31 \pm 1.8^\circ\text{F}$) for outdoor-use applications and at $0.0 \pm 1.0^\circ\text{C}$ ($32.0 \pm 1.8^\circ\text{F}$) for indoor-use applications. At least six specimens are to be subjected to the cold conditioning.

Exception: The effect-of-cold test need not be conducted on joints bonded by fusion techniques, such as solvent or ultrasonic welding, etc.

69.6 Effect of cyclic conditions

69.6.1 For each primary property to be evaluated, ten specimens shall be subjected to three complete cycles of the conditioning indicated in Table 69.1.

69.6.2 After the conditioning, the specimens shall be brought to and tested at room temperature to determine the critical property values. The average conditioned value of each property shall not be less than 50 percent of the unconditioned average value.

Table 69.1
Cycling conditions

For indoor end-use application	For outdoor end-use applications
24 hours at T followed immediately by at least 96 hours at $35.0 \pm 2.0^\circ\text{C}$ ($95.0 \pm 3.6^\circ\text{F}$), 90 percent relative humidity, followed by 8 hours at $0.0 \pm 2.0^\circ\text{C}$ ($32.0 \pm 3.6^\circ\text{F}$)	A minimum of 24 hours immersed in $25.0 \pm 2.0^\circ\text{C}$ ($77.0 \pm 3.6^\circ\text{F}$) water; followed immediately by 24 hours at T followed immediately by at least 96 hours at $35.0 \pm 2.0^\circ\text{C}$ ($95.0 \pm 3.6^\circ\text{F}$), 90 percent relative humidity; followed by 8 hours at $-35.0 \pm 2.0^\circ\text{C}$ ($-31.0 \pm 3.6^\circ\text{F}$).
Note: T is the rated temperature, but not less than 60°C (140°F).	

69.7 Other test considerations

69.7.1 If the parts joined by the adhesive are subjected to periodic forces during intended operation, the assembly shall be subjected to an endurance test as applicable to the equipment, following exposure to the effect-of-temperature test described in 69.3.1 and 69.3.2.

69.7.2 In some applications, the parts joined by the adhesive may be subjected to other environmental conditions. The resistance of adhesive-bonded joints to various corrosive media, chemical reagents, oils, fuels, etc. can be determined by subjecting the joined parts to the applicable tests described in the Standard for Polymeric Materials – Short Term Property Evaluations, (UL 746A).

69.7.3 If agreeable to those concerned, as an option, a reduced number of samples may be used, as follows:

- a) As-received – 8 specimens,
- b) Effect of Temperature – 5 specimens,
- c) Effect of Humidity – 5 specimens,
- d) Effect of Cold – 3 specimens, and
- e) Effect of Cycle Conditioning – 5 specimens.

COIL FORMS

70 Conformal Coating Test

70.1 General

70.1.1 Twenty specimens are to be provided with the minimum electrical spacing, and minimum coating thickness using the test pattern shown in Figure 70.1. The specimens are to be prepared by normal production means employing any primer or cleaner recommended by the coating manufacturer if this feature is to be considered. Lead wires are to be attached that are considered acceptable for the voltage stress and temperatures involved. See Table 70.1 for a description of the required specimens.

70.1.2 Specimens are to be prepared for the Voltage Transient and Dielectric Withstand and Breakdown tests in accordance with Table 70.1. Immediately prior to voltage transient testing, the specimens are to be wrapped with a tight-fitting aluminum foil (representing an electrically conductive contaminate deposit along the surface of the coating) that covers the test pattern but does not cover the insulated test lead wire and solder points.

Table 70.1
Test specimens

Test	Quantity of each coating thickness	Dimensions, mm (inch)	Coating thickness	
			Min	Max
Voltage Transient, Dielectric Withstand and Breakdown After:				
A As received (unconditioned)	5	a	X	–
A Environmental conditioning	5	a	X	–
B Humidity conditioning	5	a	X	–
C Thermal Conditioning	5	a	X	–
Flammability	20	127×12.7×0.8 (5×1/2×1/32)	X	X
		127×12.7×0.8 (5×1/2×1/16)	X	X
a See 70.1.1				

70.1.3 VOLTAGE TRANSIENT TEST – A 50 – 60 Hz voltage source is to be applied on the specimens between opposite legs of the test pattern, namely leads A, B, C connected together and lead D in Figure 70.1. Each sample is to be subjected to ten (10) randomly triggered (with respect to the 60 Hz supply waveform) applications of a 6 kilovolt surge impulse superimposed on the supply source at 60 second intervals. The surge generator is to have a source impedance of 50 ohms. With no load on the generator, the surge waveform shall have the following characteristics:

- a) Initial rise time of 0.5 microsecond between 10 percent and 90 percent of peak amplitude;
- b) The period of the ensuing oscillatory wave is to be 10 microseconds; and
- c) Each successive peak of alternating polarity is to be 60 percent of the preceding peak.

Refer to Figures 70.2 and 70.3 for a typical surge generation and control relay circuit. All specimens, unconditioned and conditioned, shall be subjected to the voltage transient test. There shall not be any ignition, dielectric breakdown through the coating or evidence of a carbon path being created on the surface of the coating material.

Figure 70.1
Dielectric test pattern

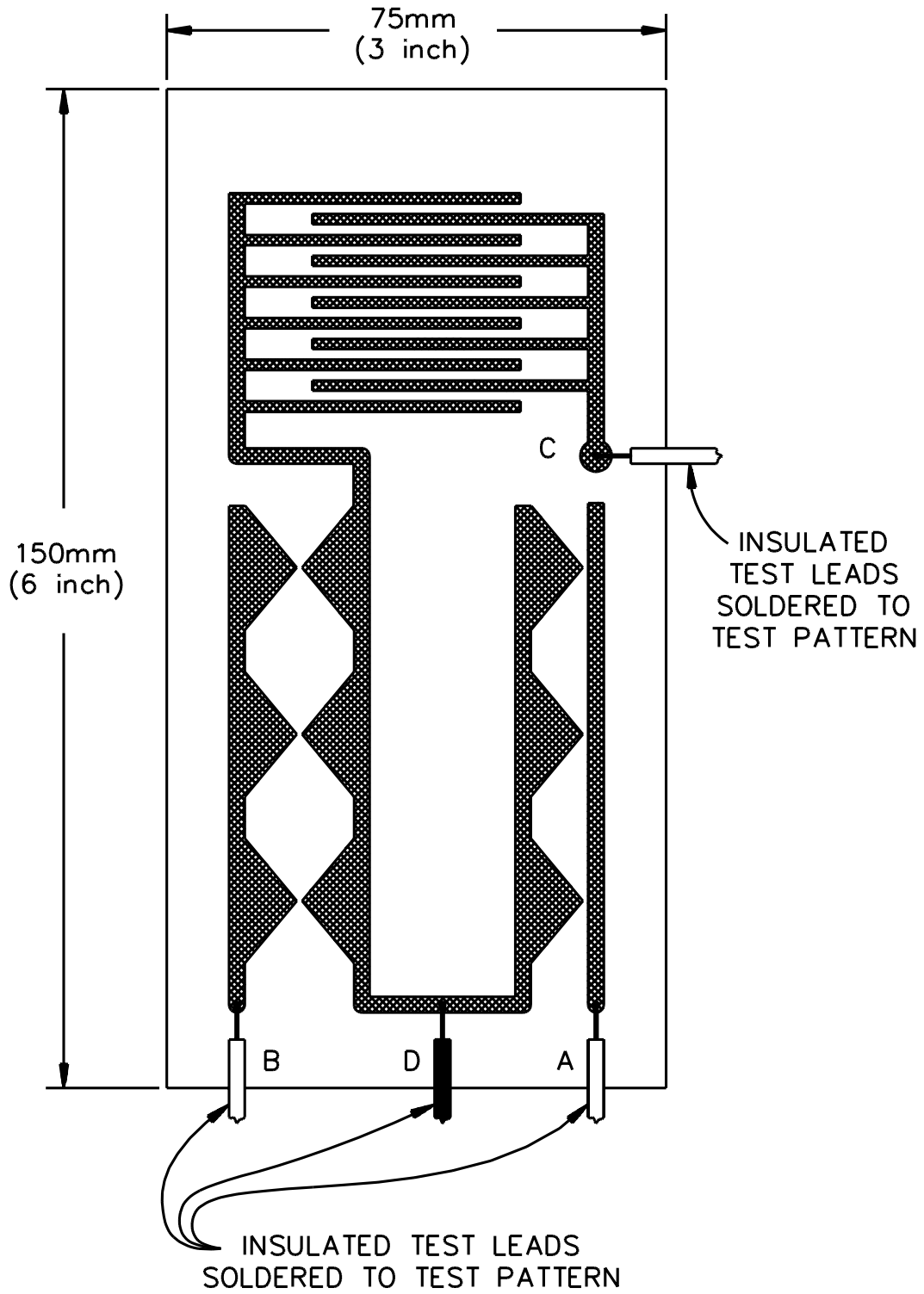

S2005B

Figure 70.2
Surge generator circuit

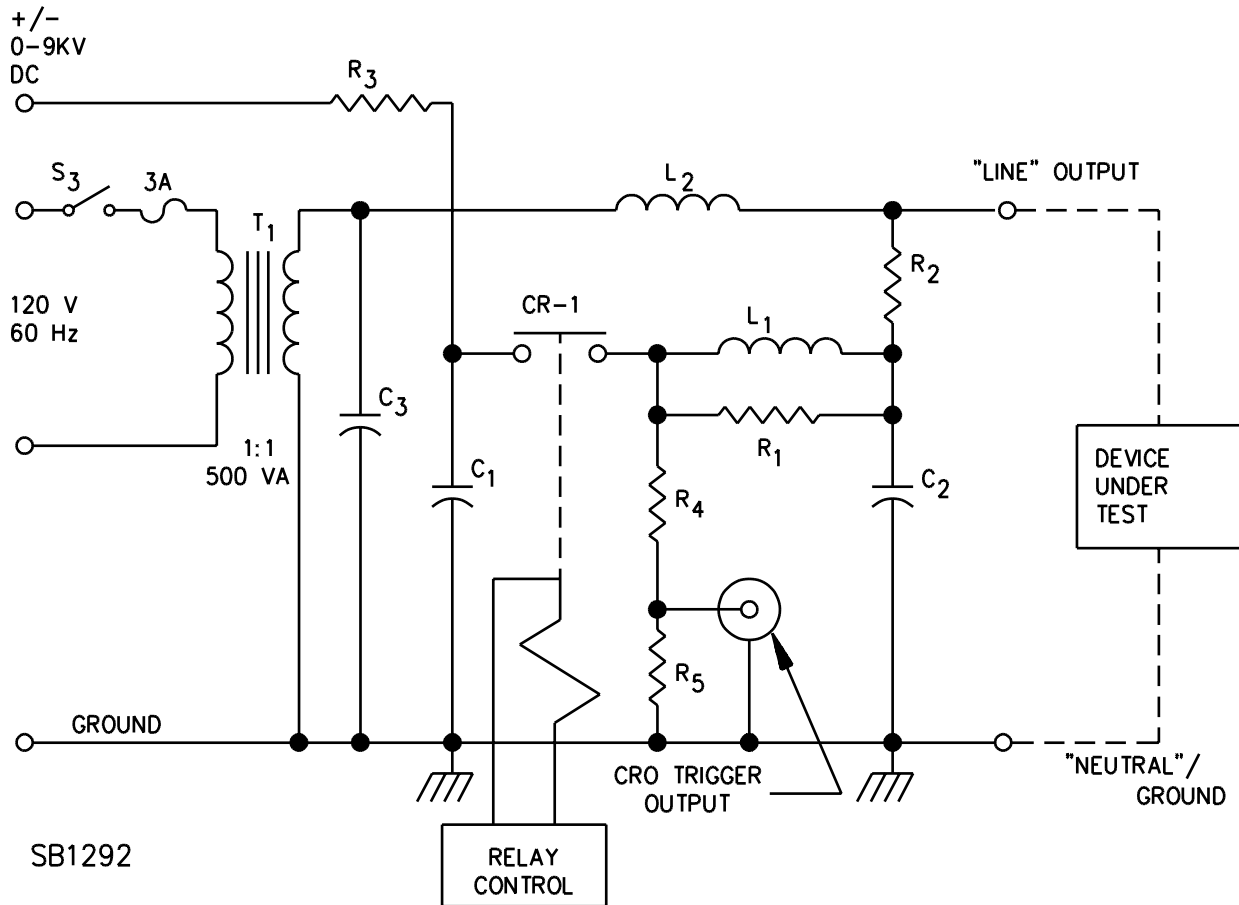

C1 = 0.025 uF, 10kV
 C2 = 0.01 uF, 10kV
 C3 = 4 uF, 400 V

R1 = 22 Ohms, 1W, composition
 R2 = 12 Ohms, 1W, composition
 R3 = 1.3M Ohms (12 x 110K Ohms, 1/2W)
 R4 = 47K Ohms (10 x 4.7K Ohms, 1/2W)

L1 = 14 uH (33 turns, No. 23 AWG wire, 0.7 inch diameter air core)
 L2 = 70 uH (44 turns, No. 14 AWG wire, 2.6 inch diameter air core) CR-1 = Relay – See Figure 70.3

Figure 70.3
Relay control circuit for surge generator

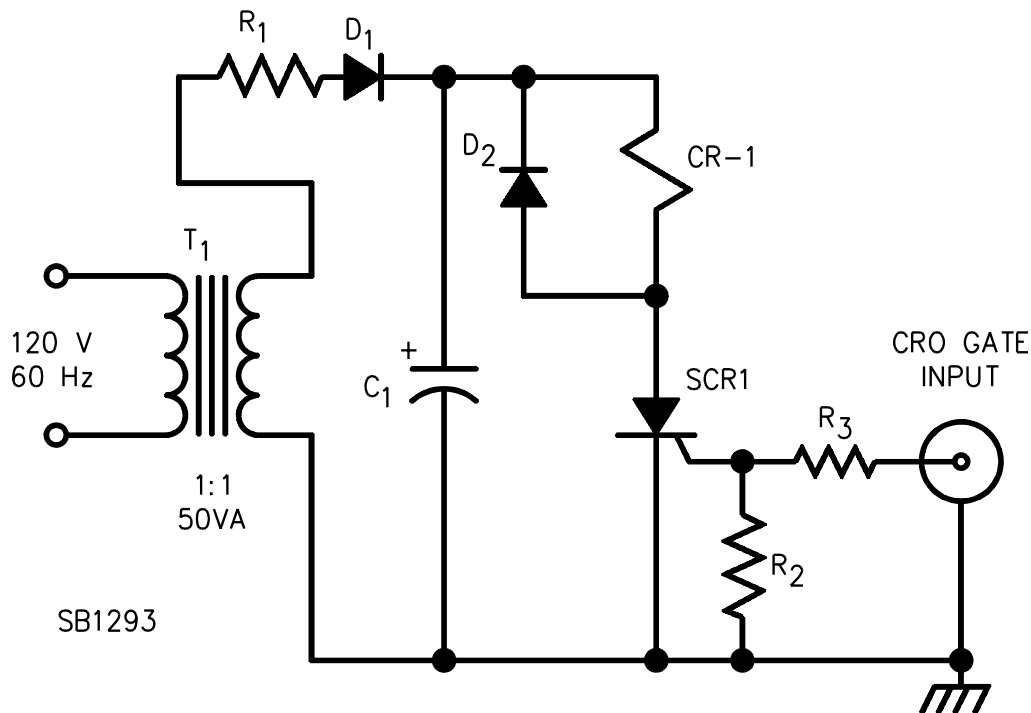

70.1.4 DIELECTRIC WITHSTAND AND BREAKDOWN TEST – The specimens subjected to the voltage Transient Test shall withstand a 1000 V potential difference for one minute without breakdown. The voltage stress is to be applied between leads A, B, C connected together and the foil covering connected to lead D. After one minute, the voltage stress is to be increased until breakdown occurs. Conditioned specimens (see 70.2.1 – 70.2.3 shall withstand the dielectric stress for one minute without breakdown and have a dielectric breakdown value at least fifty percent of the unconditioned samples.

70.2 Sample conditioning

70.2.1 ENVIRONMENTAL CYCLING CONDITIONING – Specimens are to be subjected to three complete cycles of environmental conditioning as described in Table 70.2 and then subjected to the Voltage Transient and Dielectric Voltage-Withstand and Breakdown-Voltage Test.

Table 70.2
Cycling conditions

For indoor end-use applications	For outdoor end-use applications
24 hours at T ^a followed immediately by a minimum 96 hours exposure at 35.0 ±2.0°C (95.0 ±3.6°F), 90 percent relative humidity, followed by 8 hours at 0.0 ±2.0°C (32.0 ±3.6°F).	A minimum of 24 hours immersed in 25.0 ±2.0°C (77.0 ±3.6°F) water; followed immediately by 24 hours at T ^a followed immediately at least 96 hours at 35.0 ±2.0°C (95.0 ±3.6°F), 90 percent relative humidity; followed by 8 hours at -35.0 ±2.0°C (-31.0 ±3.6°F).
a T is the normal operating temperature, but not less than 60°C (140°F).	

70.2.2 HUMIDITY CONDITIONING – Specimens are to be conditioned for 7 days at 90 – 95 percent relative humidity at $35.0 \pm 1.0^{\circ}\text{C}$ ($95.0 \pm 1.8^{\circ}\text{F}$). Within two minutes of removal from the test chamber or sealed transporting container, the specimens are to be subjected to the Voltage Transient and Dielectric Voltage-Withstand and Breakdown-Voltage Test described in 70.1.3 and 70.1.4.

70.2.3 THERMAL CONDITIONING – Specimens are to be conditioned for 1000 hours in a full draft circulating air oven maintained at the oven temperature taken from the appropriate thermal-endurance-profile line in Figure 70.1. The thermal-endurance-profile lines for ANSI Types FR2, FR3, FR4, XXXPC, and GPO-2 industrial laminates may be representative of other laminates. After conditioning, the specimens are to be cooled for a minimum of 40 hours at $23.0 \pm 2.0^{\circ}\text{C}$ ($73.4 \pm 3.6^{\circ}\text{F}$) and a 50 ± 5 percent relative humidity and then be subjected to the Voltage Transient and Dielectric Voltage-Withstand and Breakdown-Voltage Test described in 70.1.3 and 70.1.4.

Exception: On the same thermal endurance profile line in Figure 70.4, a shorter or longer time at a higher or lower temperature, respectively, may be employed if agreeable to all concerned, but a period of not less than 300 hours is to be used.

Figure 70.4
Conditioning time versus oven temperature for normal operating temperature of conformal coatings

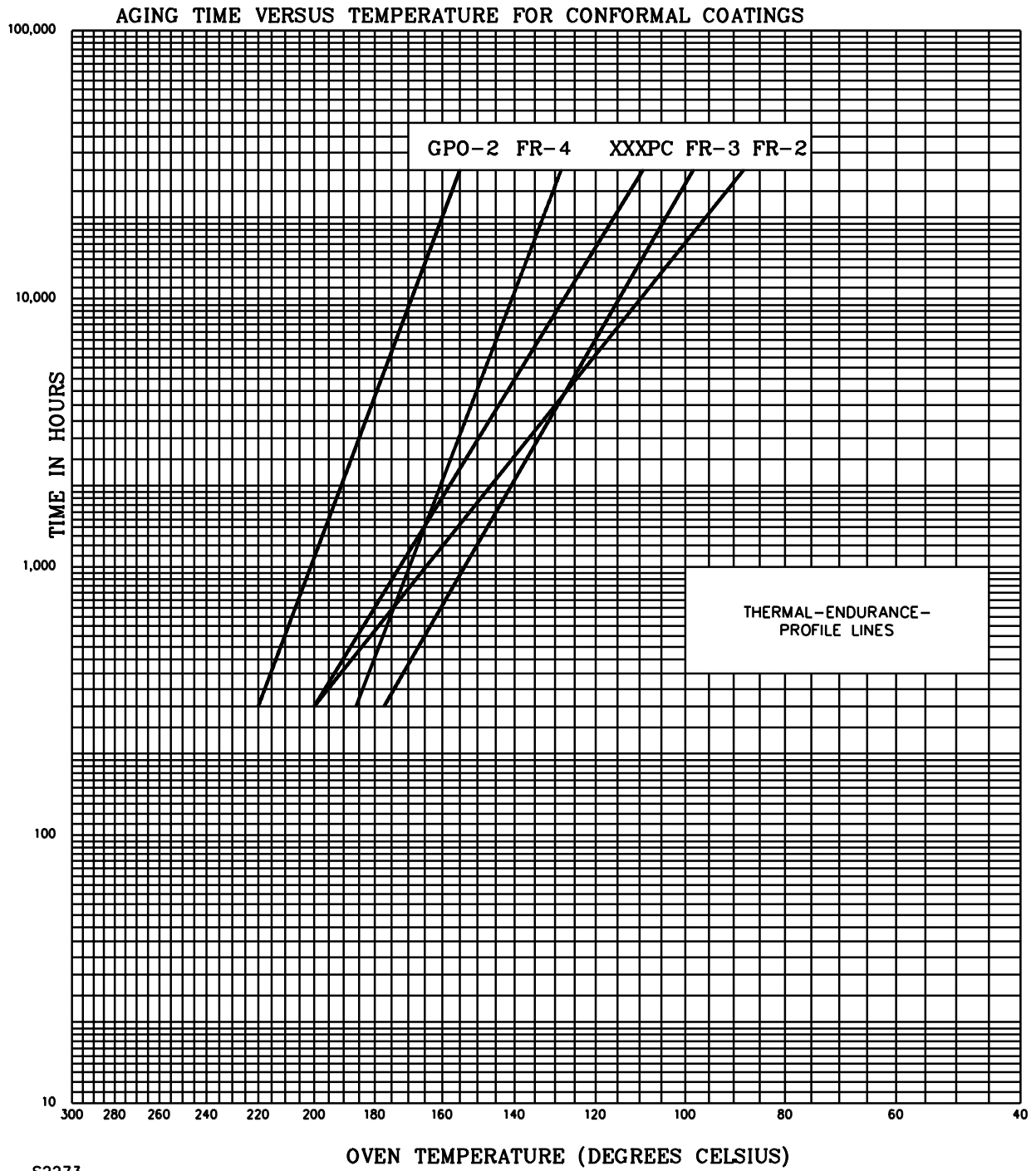

71 Metallized Parts – Performance Considerations

Section 71 deleted July 7, 1999

71.1 Deleted July 7, 1999

71A Tape Adhesion Test

Section 71A added July 7, 1999

71A.1 General

71A.1.1 The test method for conducting the Tape Adhesion Test shall be in accordance with ASTM D3359. This test method is applicable to the brittle coatings of metallized parts that are described in Section 47.

71A.1.1 revised July 7, 1999

71A.1.2 Test panels shall be selected as shown in Table 71A.1.1 for a full and short program of test. A full program is performed when the combination of the coating and substrate have not been previously tested by the coating or substrate supplier. A short program is performed when the coating and substrate have been previously tested by the coating or substrate supplier.

Exception: No testing is required for a substrate which is generically equivalent and which is similar to a substrate from the same manufacturer which has been tested with the same coating of that manufacturer.

Table 71A.1.1

Program	Number of Panels	Conditioning
Full	12	71A.5(a), (b), (c) and (d)
Short	6	71A.5(a) and (b)

71A.1.3 The tape used to measure adhesion by ASTM D3359 shall have a Tape Adhesion Strength as determined per ASTM D1000 of 36 ± 2.5 oz/in.

71A.1.3 revised July 7, 1999

71A.2 Samples

71A.2.1 Test panels shall be approximately 76 x 127 mm (3 by 5 inches), rigid, flat and with no obstructions (e.g. ridges, bosses, and ventilation openings).

71A.2.2 Each test panel shall be coated with the minimum thickness of coating being investigated.

71A.3 Coating Thickness Measurement

71A.3.1 Prior to environmental conditioning, the coating thickness for each panel is to be measured. The thickness shall be determined by a mechanical device such as a micrometer, an optical device, or a radioactive device which shall render an actual coating thickness at any given point.

71A.4 Sample Preparation

71A.4.1 For coating thicknesses up to 0.051 mm (2 mils), an 11 cross-cut is to be made. For coating thicknesses between 0.051 to 0.127 mm (2 to 5 mils), a 6 cross-cut is to be made. For coatings of greater than 0.127 mm (5 mils) an X cut is to be made. The cuts are to be made in accordance with ASTM D3359-95a, Test Method A or B.

71A.4.1 revised July 7, 1999

71A.4.2 Cuts are to be made to all panels prior to conditioning. They are to be made on a flat surface by using a sharp blade to cut through the coating to the substrate in one steady motion. If the blades are not sharp, excess coating and substrate will be removed by the rough cut. Blades should be examined for sharpness after 50 cuts or if rough cuts are observed.

71A.4.3 After cutting, brush lightly over the surface to remove excess flakes and ribbons.

71A.5 Conditioning

a) As-Received - Three specimens are to be conditioned for at least 40 hours at a temperature of $23.0 \pm 2.0^{\circ}\text{C}$ ($73.0 \pm 3.6^{\circ}\text{F}$) and a relative humidity of 50 ± 5 percent prior to testing.

b) Thermal Cycling Evaluation

1) Three specimens are to be conditioned for 1 hour at 10.0 ± 0.0 , minus 1.0°C (18.0 ± 0.0 , minus 1.8°F) higher than the normal-use temperature of the plastic, but not less than 70°C (158°F) in any case, followed by

2) One hour at $23.0 \pm 2.0^{\circ}\text{C}$ ($73.0 \pm 3.6^{\circ}\text{F}$) and a relative humidity of 50 ± 5 percent, followed by

3) One hour at minus $29.0 \pm 2.0^{\circ}\text{C}$ (minus $20.2 \pm 3.6^{\circ}\text{F}$) followed by

4) One hour at $23.0 \pm 2.0^{\circ}\text{C}$ ($73.0 \pm 3.6^{\circ}\text{F}$) and a relative humidity of 50 ± 5 percent, followed by

5) Steps 1 - 4 repeated two more times.

c) Oven - Three specimens are to be conditioned for 14 days at 10.0 ± 0.0 , minus 1.0°C (18.0 ± 0.0 , minus 1.8°F) higher than the normal-use temperature of the plastic (minimum 70°C), with testing at the end of 14 days.

d) Humidity - A second set of three specimens is to be conditioned for 14 days at $35.0 \pm 0.0^{\circ}\text{C}$ ($95.0 \pm 3.6^{\circ}\text{F}$) and 90 ± 5 percent relative humidity with testing at the end of 14 days.

71A.6 Results

71A.6.1 The test specimens shall be examined, both as received and after conditioning, as follows:

- a) Examine the grid area and the tape for removal of coating from the substrate (for adhesion failure) or separation of the coating from itself (cohesion failure).
- b) Record the percentage of coating removal from the substrate for each specimen. If the removal is cohesive, record the percentage of coating removal, using the tape as a reference.

Note: Removal due to cutting is not counted as part of the adhesive and cohesive bond removal. Removal due to cutting is evident as a pattern of traces that follow the edges of the cross hatch lattice typically seen on the tape. These are micro fractures caused by blades pressing through the coated substrate. These fractures are strong enough to resist the brushing-off of flakes and ribbons yet weak enough to be pulled up by the Tape Test.

Note: Unlike adhesive removal where the substrate becomes exposed cohesive removal is indicated by the tape containing a layer or a dusting of coating.

71A.6.2 If 5% or more of the coating is removed in Method B of ASTM D-3359 and if more than 0.8 mm (1/32 inch) of the coating is removed along the incision of the "X" cut in Method A of ASTM D-3359, the results are not acceptable.

71A.6.2 revised July 7, 1999

72 Leakage Current Test

72.1 All exposed conductive surfaces are to be tested for leakage currents. The leakage currents from these surfaces are to be measured to the grounded supply conductor individually as well as collectively where simultaneously accessible, and from one surface to another where simultaneously accessible. Parts are considered to be exposed surfaces unless guarded by an enclosure considered to provide protection against electric shock. Surfaces are considered to be simultaneously accessible when they can be readily contacted by one or both hands of a person at the same time. These measurements do not apply to terminals operating at voltages which are not considered to involve electric shock.

72.2 If a conductive surface other than metal is used for the enclosure or of the enclosure, the leakage current is to be measured using a metal foil with an area of 10 cm × 20 cm in contact with the surface. Where the surface is less than 10 cm × 20 cm, the metal foil is to be the same size as the surface. The metal foil is not to remain in place long enough to affect the temperature of the appliance.

72.3 The measurement circuit for leakage current is to be as shown in Figure 72.1. The ideal instrument is defined in (a) – (d). The meter which is actually used for a measurement need only indicate the same numerical value for a particular measurement as would the defined instrument. The meter used need not have all the attributes of the defined instrument.

- a) The meter is to have an input impedance of 1500 ohms resistive shunted by a capacitance of 0.15 microfarad.
- b) The meter is to indicate 1.11 times the average of the full-wave rectified composite waveform of voltage across the resistor or current through the resistor.

c) Over a frequency range of 0 – 100 KHz, the measurement circuitry is to have a frequency response (ratio of indicated to actual value of current) equal to the ratio of the impedance of a 1500 ohm resistor shunted by a 0.15 microfarad capacitor to 1500 ohms. At an indication of 0.5 or 0.75 mA, the measurement is to have an error of not more than 5 percent at 60 Hz.

d) Unless the meter is being used to measure leakage from one part of an appliance to another, the meter is to be connected between the accessible parts and the grounded supply conductor.

72.4 A sample of the appliance is to be tested for leakage current starting with the as-received condition but with its grounded conductor, if any, open at the attachment plug. The as-received condition is without prior energization except as may occur as part of the production-line testing. The supply voltage is to be adjusted to 120 V. The test sequence, with reference to the measuring circuit, (Figure 72.1) is to be as follows:

a) With switch S1 open, the appliance is to be connected to the measuring circuit. Leakage current is to be measured using both positions of switch S2 and with the appliance switching devices in all their normal operating positions.

b) Switch S1 is then to be closed energizing the appliance, and within a period of 5 seconds, the leakage current is to be measured using both positions of switch S2, and with the appliance switching device in all their normal operating positions.

c) The leakage current is to be monitored until thermal stabilization. Both positions of switch S2 are to be used in determining this measurement. Thermal stabilization is to be obtained by operation as in the temperature test.

72.5 Normally a sample will be carried through the complete leakage current test program as covered by 72.4, without interruption for other tests. With the concurrence of those concerned, the leakage current tests may be interrupted for the purpose of conducting other non-destructive tests.

73 Glow-Wire End-Product Test

Section 73 added April 12, 1995

73.1 General

73.1.1 This method is intended to determine compliance of an end-product to satisfactorily withstand the effects of an electrically heated wire as described in The Method for Glow-Wire End-Product Test, IEC 695-2-1/1.

Figure 72.1
Leakage-current measurement circuit

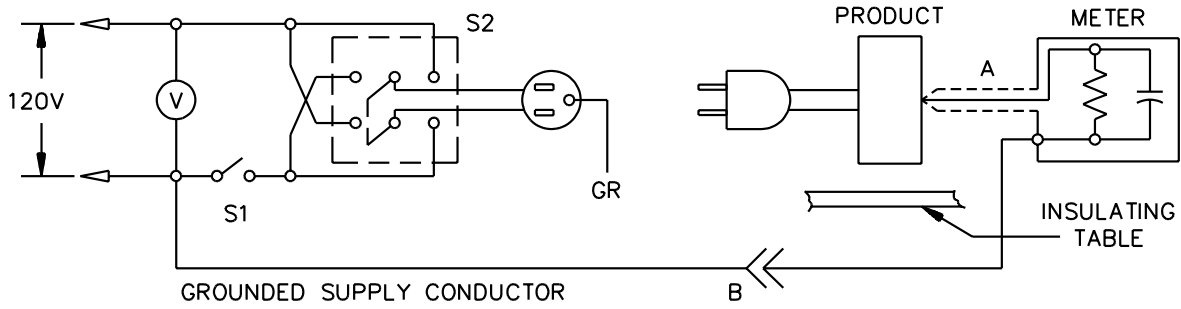

Appliance intended for connection to a 120 V power supply.

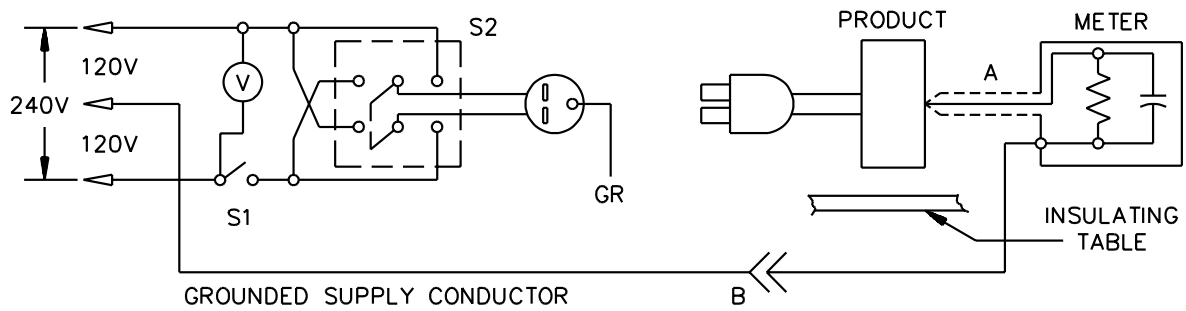

Appliance intended for connection to a 3-wire, grounded neutral power supply, as illustrated above.

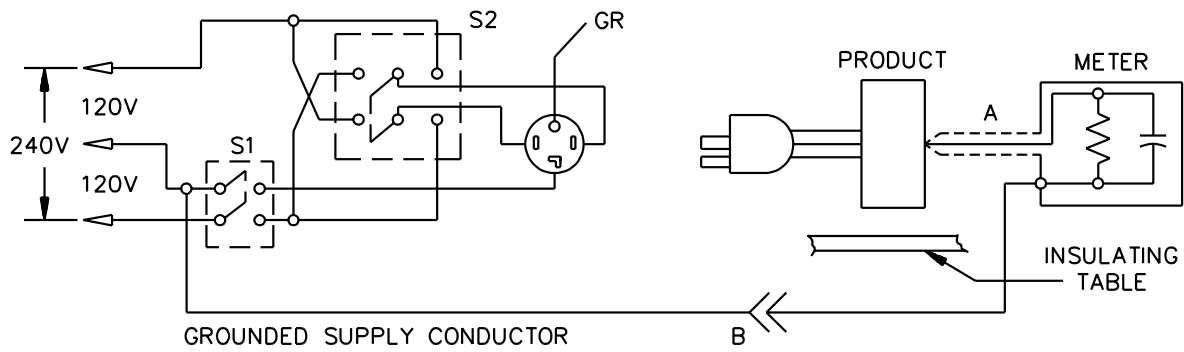

Appliance intended for connection to a 3-wire, grounded neutral power supply, as illustrated above.

A PROBE WITH SHIELDED LEAD.

B SEPARATED AND USED AS CLIP WHEN MEASURING CURRENTS FROM ONE PART OF APPLIANCE TO ANOTHER.

73.2 Significance

73.2.1 Either during normal operation, under unusual conditions, or as a result of malfunctions, some components of an electrical apparatus, such as wires or other conductors may become abnormally hot. When these overheated parts are in intimate contact with the insulating material, ignition may occur. This test is intended to determine compliance, under these conditions, of an insulating material incorporated in and end-product.

73.3 Apparatus

73.3.1 The basic components of the test apparatus as follows:

- a) Glow-Wire – Nichrome wire (nominal 80 percent nickel /20 percent chromium) with a nominal 4.0 mm (0.16 inch) diameter formed to the dimensions shown in Figure 73.1.
- b) Thermocouple – A sheathed fine-wire thermocouple, having an overall nominal diameter of 0.5 mm (0.02 inch) and wires (type K) of, for example, NiCr and NiAl suitable for continuous operation at temperatures up to 960°C (1760°F) with the welded point located inside the sheath. The thermocouple is arranged in a pocket hole, drilled in the tip of the glow-wire, as shown in the detail of Figure 76.1. Maintain the thermal contact between the tip of the thermocouple and the end and sides of the bored hole.
- c) Temperature Indicator – A temperature indicator for Type K thermocouples capable of reading to 1000°C (1832°F) and with an accuracy of 1°C (1.8°F).
- d) Supply Circuit – current transformer with a 2.1 V open circuit, secondary voltage. The transformer having sufficient kVA to supply from 0 to 115 A to the test circuit. There must also be a means for smooth and continuous adjustment of the power level to achieve the desired glow-wire tip temperature.
- e) Test Fixture – Designed so that the glow-wire is kept in a horizontal plane and applies a force of 1.0 ± 0.2 N to the specimen. Maintain the force as the glow-wire is moved horizontally towards the specimen or visa versa over a distance of at least 7mm (0.28 inch).
- f) Flaming Particle Indicator – A piece of flat smooth white pinewood board, approximately 10 mm (0.39 inch) thick, and in close contact with a single layer of tissue paper, located a distance of 200 ± 5 mm (7.87 ± 0.20 inch) below the glow-wire tip. Use undyed, soft, strong, lightweight tissue paper weighing between 12 and 30 g/m²

Note: If known, replace the white pinewood board and tissue paper with the materials normally situated around and underneath the end-product during normal operation. Also, adjust the distances of these materials from the end-product to the distances usually encountered during normal operation.

73.4 Specimens

73.4.1 The specimen should be the complete equipment, sub-assembly or component under investigation. If this is not possible, cut off a piece of the equipment containing the part under investigation.

73.5 Conditioning

73.5.1 The specimen is to be conditioned at $23 \pm 2^\circ\text{C}$ ($73.4 \pm 3.6^\circ\text{F}$) and 50 ± 5 percent relative humidity for at least 40 hours prior to testing.

73.6 Procedure

73.6.1 The tip of the glow-wire is to be applied to the thinnest portion of the specimen that is likely to be subjected to thermal stresses during normal use (but preferably not less than 15 mm (0.59 inch) from any edge). Mount the specimen in the test fixture so that the surface coming in contact with the tip of the glow-wire is vertical. Electrically heat the clean glow-wire to a temperature determined from Table 73.1. Keep this temperature (and the heating current) constant for at least 60 s prior to testing. The tip of the glow-wire is then brought into contact with the specimen with an applied force of 1.0 ± 0.2 N for 30 ± 1 s. Maintain the glow-wire current constant during this period and mechanically limit the movement of the glow-wire tip into the specimen to 7 mm (0.28 inch).

73.6.2 If ignition occurs, note the time from the beginning of the glow-wire application to the time at which the specimen, the parts surrounding the specimen, or the flaming particle indicator ignites. For the purposes of this method, ignition is defined as either a visible flame on the specimen (or parts surrounding the specimen) for more than 5 seconds, or ignition of the flaming particle indicator due to particles falling from the specimen.

73.6.3 After the 30 ± 1 s application period, remove the glow-wire from the specimen at a rate which limits any further heating of the specimen, but slowly enough so as to avoid any movement of air which might affect the results of the test. Continue observation of the specimen, the parts surrounding the specimen, and the flaming particle indicator, for an additional 30 ± 1 s. Disregard ignition of the flaming particle indicator due to flaming particles falling from the glow-wire. If ignition occurred during the application of the glow-wire, note whether or not all flaming and glowing ceased within 30 ± 1 s after removal of the glow-wire.

73.6.4 The specimen is considered to have satisfactorily withstood the glow-wire end-product test if either:

- a) There is no ignition, or
- b) All flaming and glowing of the specimen, the parts surrounding the specimen, and (if a material was used other than the tissue paper/pinewood board) the flaming particle indicator, ceases within 30 ± 1 s after removal of the glow-wire. The results are not acceptable if the specimen, the parts surrounding the specimen, or the flaming particle indicator are completely consumed.

Table 73.1
Glow-wire temperature requirements based upon a products functional end-use application

Application type	Glow-wire temperature
Portable, attended, intermittent duty, household use equipment	650°C
All other portable equipment	750°C
Fixed or stationary equipment	750°C

MARKING

74 General

Section 74 added April 12, 1995

74.1 Material containers shall be marked with the following:

- a) The manufacturer's or private labeler's name or identifying symbol.
- b) A distinctive material designation.

74.2 If a manufacturer produces the material at more than one factory, each material container shall have a distinctive marking to identify it as the product of a particular factory.

Figure 73.1
Glow-wire configuration
Figure 73.1 revised July 15, 1998

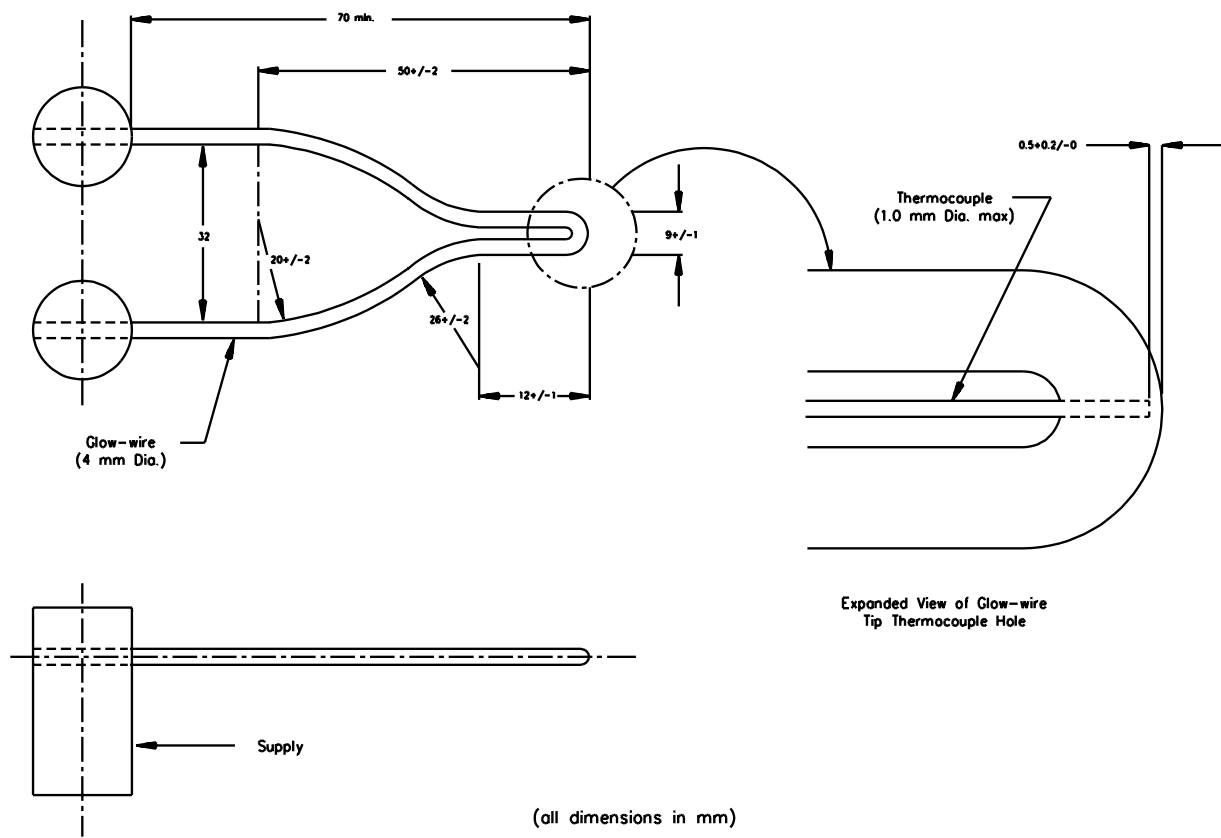

SM1224

No Text on This Page

APPENDIX A

Guidelines for Evaluation of Substitute Polymeric Materials

A Alternate Enclosure Material Considerations

Relocated from Section 7

A.1 From time-to-time, it may be necessary to select alternative or substitute materials for use. These considerations apply only to alternate materials for a given part. Changes in part dimensions and, in particular, reductions in material thickness, generally require an evaluation using all the end-product tests.

A.1 added October 16, 2000

A.2 It may not be necessary that a complete series of end-product tests be required, provided that equivalent or better material properties can be demonstrated by standardized small-scale tests on the candidate material when compared to the properties of a material having acceptable application performance.

Exception: A candidate material that does not provide equivalent material properties to the properties of a material having acceptable application performance, may be acceptable providing that the candidate material possesses the minimum performance level required in Table 4.1 and/or Table 8.1 for the application.

Revised A.2 effective June 1, 2004

A.3 Table A.1 indicates general guidelines that can be used to evaluate alternate or substitute materials if small-scale test data is available. It should be noted that these guidelines apply to substitutions within the same class of materials (thermoplastic to thermoplastic and thermoset to thermoset).

A.3 added October 16, 2000

A.4 Except as indicated in Table A.1, if the originally tested material was considered acceptable based upon special tests (for example, determining the resistance of the material to ultraviolet light for an outdoor application or tests required by the end-product standard such as resistance to creep, endurance, and overload), these tests are to be conducted on the candidate material to determine acceptability.

A.4 added October 16, 2000

A.5 In Table A.1, the material property parameters are tabulated in column 1. Acceptance guidelines for those situations where the candidate material properties are equivalent to or better than the characteristics of the original material are tabulated in column 2.

A.5 added October 16, 2000

A.6 For those properties where the candidate material is not equal to or better than those for the original material, column 3 of Table A.1 indicates the considerations that should be given to the original requirements for the specific application.

A.6 added October 16, 2000

A.7 Column 4 of Table A.1 indicates the required end-product tests needed if the candidate materials' properties are not equivalent to the original material's properties nor meet the requirements for the application.

A.7 added October 16, 2000

A.8 As an example, if the original enclosure material was a Type 66 nylon (PA66) and the candidate material is a polycarbonate (PC), then for each property parameter tabulated in column 1, the end-product test in column 4 would be required if the candidate material properties are not equivalent to the original material properties (column 2) or does not meet the original requirements for the specific application (column 3).

A.8 added October 16, 2000

Table A.1
Alternative material consideration

Revised Table A.1 effective June 1, 2004

Material property parameters (Column 1)	Candidate material characteristics, equivalent or better than characteristics of the original material considered acceptable for the application (Column 2)	Candidate material characteristics, equivalent or better than those required for the application (Column 3)	Candidate material characteristics not equivalent to original material characteristics nor meets those required for the application (Column 4)
FLAMMABILITY (flammability classification at use thickness and color)	Candidate Material Considered Acceptable	Candidate Material Considered Acceptable	Conduct flame test on part or enclosure (See Flammability – 12 mm Flame, Section 17, Flammability – 127 mm (5 inch) Flame, Section 19, Enclosure Flammability – Large Mass Considerations, Section 21)
ELECTRIC STRENGTH (1) Volume resistivity (2) Dielectric Strength	Candidate Material Considered Acceptable	Candidate Material Considered Acceptable	Conduct end-product (1) leakage current tests or insulation resistance complying with 16.3 (2) dielectric withstand complying 12.1
TRACKING RESISTANCE (1) Comparative tracking index or (2) Inclined Plane Tracking	Candidate Material Considered Acceptable	Candidate Material Considered Acceptable	(1) Increase spacings to $\geq \frac{1}{2}$ in. (2) Increase spacings to: Refer to applicable end-product considerations.
WATER RESISTANCE (1) Dimensional change after water exposure (2) Properties after water immersion (Outdoor use only) Also see A.4	Candidate Material Considered Acceptable	Candidate Material Considered Acceptable	Conduct end-product Humidity/immersion tests per 27.2 Material is not suitable for prolonged exposure to water
ULTRA-VIOLET RESISTANCE			

Table A.1 Continued on Next Page

Table A.1 Continued

Material property parameters (Column 1)	Candidate material characteristics, equivalent or better than characteristics of the original material considered acceptable for the application (Column 2)	Candidate material characteristics, equivalent or better than those required for the application (Column 3)	Candidate material characteristics not equivalent to original material characteristics nor meets those required for the application (Column 4)
Properties after ultra-violet exposure. (Outdoor use only) Also see A.4	Candidate Material Considered Acceptable	Candidate Material Considered Acceptable	Material is not suitable for exposure to weather
RESISTANCE TO ELECTRICAL IGNITION (1) Hot- wire ignition and flame classification combination, (2) High current arc resistance and flame classification combination	Candidate Material Considered Acceptable	Candidate Material Considered Acceptable	Conduct end-product: Abnormal Overload Test or Glow Wire Test per section 14 Arc-Resistance Test per par. 13.3 – 13.5
MECHANICAL (See note b) (1) Tensile or Flexural Strength (2) Tensile or Izod impact or Charpy	Candidate Material Considered Acceptable ^a	NA	Conduct end-product (1) Crushing Resistance per 23.1 and Strain Relief per 32.1 or Conduit tests per UL 50 or UL 508 (2) Impact Resistance per Sec. 24 and Strain Relief per 32.1 or Conduit tests per UL 50 or UL 508
DEFORMATION (See notes a) (1) Heat Deflection (2) Creep	Candidate Material Considered Acceptable ^a	NA	Conduct end-product Mold Stress-Relief test. Test is not required for thermoset materials. All alternative or substitute materials are to be subjected to end product creep tests (see Section 24A) unless: a) The candidate material is of the same composition b) The candidate has equivalent of higher small-scale heat deflection, vicat softening, or ball pressure temperature indices. c) The candidate has equivalent creepage characteristics based on tests and/or test data (Note - the test results being compared must have the same test parameters) Creep evaluations are not required for rigid thermoset materials.
MAXIMUM USE TEMPERATURE	Refer to Sections 33 – 39		
SPECIAL END-USE CONSIDERATIONS^b	If indicated by the applicable path in Table 4.1 all alternative or substitute materials are to be subjected to the abnormal operation (28.1) and severe conditions tests (29.1), unless the candidate is of the same generic type with the same percentage and type of fillers, reinforcements, heat stabilizers and flame retardants.		

Table A.1 Continued on Next Page

Table A.1 Continued

Material property parameters (Column 1)	Candidate material characteristics, equivalent or better than characteristics of the original material considered acceptable for the application (Column 2)	Candidate material characteristics, equivalent or better than those required for the application (Column 3)	Candidate material characteristics not equivalent to original material characteristics nor meets those required for the application (Column 4)
<p>^a All alternative or substitute materials are to be subjected to end-product impact, crush, conduit, strain relief and mold stress-relief tests unless:</p> <ol style="list-style-type: none"> 1) The candidate material is of the same generic type with the same percentage and type of fillers and reinforcements, and 2) The candidate material has equivalent or higher small-scale tensile or flexural strength, tensile or izod impact and heat deflection ratings indicated above. <p>^b See A.4</p>			

October 16, 2000
Superseded requirements for
the Standard for
Polymeric Materials – Use in Electrical Equipment Evaluations
UL 746C, Fourth Edition

The requirements shown are the current requirements that have been superseded by requirements in revisions issued for this Standard. To retain the current requirements, do not discard the following requirements until the future effective dates are reached.

3.3 ATTENDED INTERMITTENT-DUTY HOUSEHOLD APPLIANCE– An appliance intended for infrequent and short-time use in residences and used only while attended, such as an electric knife, electric can opener, hair dryer and the like.

Revised 3.3 effective June 1, 2004

4.1 The requirements for polymeric enclosures, or parts of enclosures of appliances and equipment are contained in Sections 5 – 7.

4.1 effective until June 1, 2004

5 Portable Appliances

5.1 Portable appliances having an enclosure of polymeric material shall comply with the applicable requirements in Figure 5.1. The use of Figure 5.1 is explained in 5.7 – 5.11.

5.1 effective until June 1, 2004

5.2 The requirements in Portable Appliances, Section 5, do not cover the additional considerations that must be given to enclosures employing large masses of polymeric materials. Whether or not such enclosures reduce the risk of electric shock or fire, or both, consideration should be given to the probability of ignition of the material by sources within the equipment or by external sources.

5.2 effective until June 1, 2004

5.3 A polymeric material which can contact electrically live parts, or is within 0.79 mm (1/32 inch) of uninsulated live parts, shall comply with the requirements indicated in Table 8.1.

5.3 effective until June 1, 2004

5.4 The requirements in Portable Appliances, Section 5, do not cover the additional considerations that must be given to enclosure materials exposed to oils, acids, solvents, cleaning agents, and the like in use. The performance of the material shall not be adversely affected by such environments (if encountered in the end-use application) as determined by applicable tests as detailed in the Standard for Polymeric Materials – Short Term Property Evaluation, UL 746A.

5.4 effective until June 1, 2004

5.5 The thermal endurance of a polymeric material shall be considered with respect to the requirements in Sections 33 – 38.

5.5 effective until June 1, 2004

5.6 Polymeric material used to enclose a metal housing that encloses insulated or uninsulated live parts or as a decorative part, shall be classed either 5VA, 5VB, V-0, V-1, V-2, or HB by the burning tests described in the requirements for tests for flammability of plastic materials, UL 94.

Exception No. 1: Decorative parts are not required to be made of a material classed 5VA, 5VB, V-0, V-1, V-2, or HB, providing the part: does not occupy a volume greater than 2 cubic centimeters (0.122 cubic inch), does not have any dimension greater than 3 cm (1.18 inch), and is located so it cannot propagate flame from one area to another or bridge between a possible source of ignition and other ignitable parts.

Exception No. 2: A material is to be considered equivalent if it complies with the requirements in 17.1, 51.1 – 51.5, 19.1, 53.1 – 53.5, when flame tested as used in the equipment. The use of a flame-retardant coating applied to the inside of a polymeric enclosure is not acceptable unless the coating/material interface is found to be acceptable by separate investigation (see Flame-Retardant Coatings, Section 22).

5.6 effective until June 1, 2004

Figure 5.1
Enclosure requirements for portable appliances

Figure 5.1 effective until June 1, 2004

Part 1 – Conditions of use

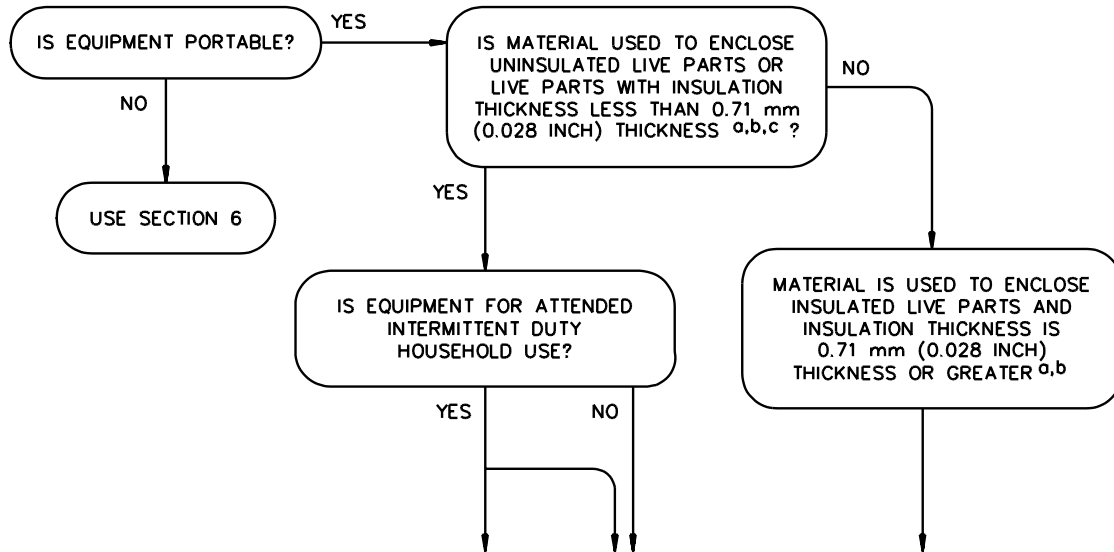

Part 2 – Applicable requirements

Minimum flammability rating	HB	v e,f	HB or v e,f
Electrical/Mechanical Properties per Table 8.1	Yes	Yes	Yes
Hot-Wire Ignition per Hot-Wire Ignition (HWI) – Abnormal Overload Test, Section 14	Max PLC of 4	Max PLC of 4 ^g	No
Impact Test per Resistance to Impact, Section 24	Yes	Yes	Yes
Abnormal Operation Test per 28.1	Yes	Yes	Yes
Severe Conditions Test per 29.1	Yes	No	No
Mold-Stress Relief Distortion per: A. 62.1	No	Yes	Yes
B. 62.2	Yes	No	No
Input after Mold-Stress Relief Distortion per 31.1	Yes	No	No
Creep per Section 24A ^h	Yes	Yes	Yes
Strain Relief Test per 32.1 ^d	Yes	Yes	Yes
Thermal Endurance per Sections 33 – 39	Yes	Yes	Yes
Volume Resistivity per Volume Resistivity, Section 16	Yes	Yes	No

Figure 5.1 (Cont.)

- ^a The insulation thickness of the component parts is considered to be equivalent to 0.71 mm (0.028 inch) if the component complies with the requirements for the component.
- ^b 0.71 mm (0.028 inch) thickness is generally required for internal insulation. However, if insulation or wire insulated with less than 0.71 mm (0.028 inch) insulation thickness (light duty) is provided that is restricted for use in chassis, channels or other internal areas where contact during user servicing or user operation of the equipment is unlikely, the insulation is considered to be equivalent to 0.71 mm (0.028 inch).
- ^c Enamel insulated magnet wire is to be considered as an uninsulated live part.
- ^d This test is required only if the strain-relief means is secured to the enclosure or is an integral part of the polymeric enclosure.
- ^e V = V-0, V-1, V-2 classed material, or enclosure material complies with the 12 mm end-product flame test described in Flammability – 12 mm Flame, Section 17.
- ^f As an alternative to the 12 mm end-product flame test, the 3/4 inch end-product flame test may be used.
- ^g The Hot-Wire Ignition criteria is applied only for materials used to enclose uninsulated live parts.
- ^h This test is only required if the equipment enclosure is subject to mechanical stresses from internal or external sources (such as bending, compression, or tensile loading) and the material used is not a rigid thermoset.

S3468F

5.7 The path shown on Part 1 of Figure 5.1 that matches the conditions of use for the polymeric material under consideration determines the requirements to be met.

5.7 effective until June 1, 2004

5.8 Following the path in Part 1 of Figure 5.1 (selected using 5.7) leads to Part 2 and the applicable material requirements. It may be necessary to determine whether the equipment is of an attended, intermittent-duty, household-use type before the applicable material requirements can be selected.

5.8 effective until June 1, 2004

5.9 Part 2 of Figure 5.1 indicates the required tests (marked with a "yes" and with a footnote reference if necessary) under the applicable path determined in Part 1 of Figure 5.1.

5.9 effective until June 1, 2004

5.10 For example, a polymeric material used to enclose uninsulated live parts, such as a heating element, of an unattended household-use electric toaster, shall only be made from a V-rated material (second path from the left of Figure 5.1), specifically either V-0, V-1, V-2 or a material that complies with the requirements in 17.1, and 51.5 – 51.5.

5.10 effective until June 1, 2004

5.11 Using this example, the material shall comply with the applicable requirements for:

- a) Hot-wire ignition per Section 14,
- b) Resistance to impact per 24.1 and 57.3,
- c) Mold stress-relief distortion per 62.1,

- d) Creep per Section 24A,
- e) Strain relief per 32.1,
- f) Abnormal operation per 28.1,
- g) Enclosure flammability per Section 17 or 18.
- h) Mechanical/electrical properties per Table 8.1, and
- i) Thermal endurance per Sections 33 – 39.

5.11 effective until June 1, 2004

6 Fixed or Stationary Equipment

6.1 Electrical equipment that is fixed or stationary and not easily carried or conveyed by hand and that has an enclosure of polymeric material shall comply with the applicable requirements in Table 8.1 and Figure 6.1. The use of Figure 6.1 is explained in 6.7 – 6.11.

6.1 effective until June 1, 2004

6.2 The requirements in Fixed or Stationary Equipment, Section 6, do not cover the additional considerations that must be given to enclosures employing large masses of polymeric materials. Whether or not such enclosures protect against electric shock and/or the likelihood of fire, consideration should be given to the probability of ignition of the material by sources within the equipment or by external sources. See 21.1 for large mass flammability considerations.

6.2 effective until June 1, 2004

6.3 A polymeric material used for the support of electrically live parts, shall comply with the requirements indicated in Table 8.1.

6.3 effective until June 1, 2004

6.4 The requirements in Fixed or Stationary Equipment, Section 6, do not cover the additional considerations that must be given to enclosure materials exposed to oils, acids, solvents, cleaning agents, and the like in production equipment. The performance of the material shall not be adversely affected by such environments (if encountered in the end-use application) as determined by applicable tests as detailed in the Standard for Polymeric Materials – Short Term Property Evaluation, UL 746A.

6.4 effective until June 1, 2004

6.5 See Sections 33 – 39 for considerations of thermal endurance and Mechanical/Electrical Property Considerations, Section 8, for additional considerations of the mechanical/electrical properties of enclosure materials.

6.5 effective until June 1, 2004

6.6 Polymeric material used to enclose a metal housing that encloses insulated or uninsulated live parts or as a decorative part, shall be classed either 5VA, 5VB, V-0, V-1, V-2, or HB by the burning tests described in the requirements for tests for flammability of plastic materials, UL 94.

Exception No. 1: Decorative parts are not required to be made of a material classed 5VA, 5VB, V-0, V-1, V-2, or HB, providing the part: does not occupy a volume greater than 4000 cubic millimeters (0.24 cubic inch), does not have any dimension greater than 60 mm (2.4 inch) and is located so it cannot propagate flame from one area to another or bridge between a possible source of ignition and other ignitable parts.

Exception No. 2: A material is to be considered equivalent if it complies with the requirements in 17.1, 51.1 – 51.6 or 19.1, 53.1 – 53.5, when flame tested as used in the equipment. The use of a flame-retardant coating applied to the inside of a polymeric enclosure is not acceptable unless the coating/material interface is found to be acceptable by separate investigation (see Flame-Retardant Coatings, Section 22).

6.6 effective until June 1, 2004

6.7 The path shown on Part 1 of Figure 6.1 that matches the conditions of use for the polymeric material under consideration determines the requirements to be met.

6.7 effective until June 1, 2004

6.8 Following the path in Part 1 of Figure 6.1 (selected using 6.7) leads to the applicable requirements and the test considerations to be considered in Part 2 of Figure 6.1.

6.8 effective until June 1, 2004

6.9 Part 2 of Figure 6.1 indicates the required tests (marked with a “yes” and with a footnote reference if necessary) under the applicable path determined in Part 1 of Figure 6.1.

6.9 effective until June 1, 2004

Figure 6.1
Enclosure requirements for fixed or stationary equipment

Figure 6.1 effective until June 1, 2004

Part 1 – Conditions of use

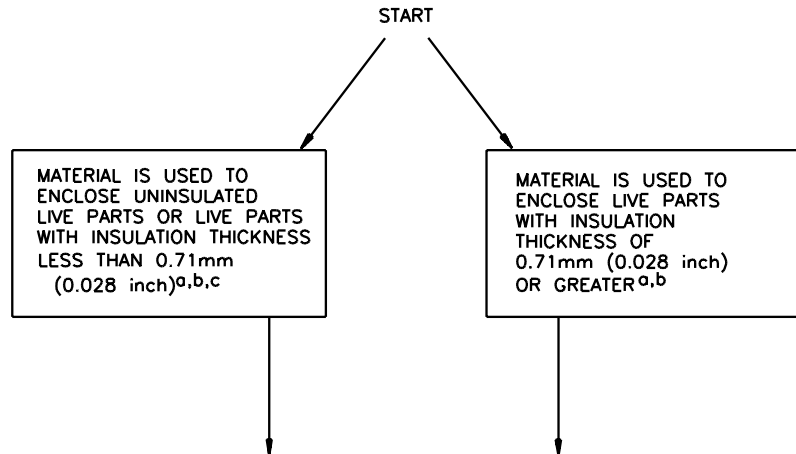

Part 2 – Applicable requirements

Minimum flammability rating	5V ⁱ	5V ⁱ
ELECTRICAL/MECHANICAL PROP. PER TABLE 8.1	YES	YES
DIELECTRIC WITHSTAND PER 12.1	YES	NO
LARGE MASS FLAMMABILITY PER SECTION 21	YES	YES
CRUSHING RESISTANCE PER 23.1	YES	NO
RESISTANCE TO IMPACT PER SECTION 24	YES	YES
UV RESISTANCE PER 26.1	YES ^f	YES ^f
WATER EXPOSURE AND IMMERSION		
A. PROPERTIES PER 27.1	YES ^f	YES ^f
B. DIMENSION PER 27.2	YES	NO
ABNORMAL OPERATION PER 28.1	YES	YES
SEVERE CONDITIONS PER 29.1	YES	YES ^g
MOLD STRESS–RELIEF DISTORTION PER 62.1	YES	YES ^d
INPUT AFTER MOLD STRESS–RELIEF DISTORTION PER 31.1	YES	YES ^g
CREEP PER SECTION 24A	YES ^j	YES ^j
CONDUIT CONNECTIONS	YES ^h	YES ^h
STRAIN RELIEF PER 32.1	YES ^e	YES ^e
THERMAL ENDURANCE PER SECTIONS 33 – 39	YES	YES
VOLUME RESISTIVITY PER SECTION 16	YES	NO

Figure 6.1 (Cont.)

- a The insulation thickness of the component parts is considered to be equivalent to 0.71 mm (0.028 inch) if the component complies with the requirements for the component.
- b 0.71 mm (0.028 inch) thickness is generally required for internal insulation. However, if insulation or wire insulated with less than 0.71 mm (0.028 inch) insulation thickness (light duty) is provided that is restricted for use in chassis, channels or other internal areas where contact during user servicing or user operation of the equipment is unlikely, the insulation is considered to be equivalent to 0.71 mm (0.028 inch).
- c Enamel insulated magnet wire is to be considered as an uninsulated live part.
- d This test is required only if failure of the material causes a stress on the junction between a lead and a terminal of a component. If the strain-relief test is acceptably performed for components with integral leads either as a separate test or as part of the regular test procedure for the component, it shall be considered that the material does not cause a stress on the junction between the lead and a terminal of the component.
- e This test is required only if the strain-relief means is mounted to the enclosure or is a polymeric part of the enclosure.
- f This test is required only if the equipment may be exposed to outdoor weather conditions.
- g This test is required only if the equipment may be used unattended.
- h This test is required only if the equipment is permanently connected electrically to the wiring system. The continuity of the conduit system shall be a metal-to-metal contact. If the integrity of the polymeric enclosure is relied upon to provide for bonding between the parts of the conduit system at any location where conduit may be connected, the bonding shall be evaluated by the requirements contained in the Standard for Enclosures for Electrical Equipment, UL 50. If the polymeric enclosure is intended for connection to a rigid conduit system, it shall acceptably perform when tested using the pullout, torque and bending tests as described in the Standard for Industrial Control Equipment, UL 508.
- i 5V = 5VA or enclosure material complies with the 5 inch End-Product Flame Test described in Flammability – 127 mm (5 inch) Flame, Section 19.
- j This test is only required if the equipment enclosure is subject to mechanical stresses from internal or external sources (such as bending, compression, or tensile loading) and the material used is not a rigid thermoset.

S3467E

6.10 For example, a polymeric material used to enclose uninsulated live parts (such as the motor windings) of a permanently wired, indoor-use ceiling fan shall be made from a 5VA classed material or a material that complies with the requirements in 19.1, 53.1 – 53.5.

6.10 effective until June 1, 2004

6.11 Using the above example, the material shall also comply with the applicable requirements for:

- a) Electrical/mechanical properties per Table 8.1,
- b) Dielectric strength per 12.1,
- c) Flammability testing per Flammability– 127 mm (5 inch) Flame, Section 19 and Enclosure Flammability – Large Mass Considerations, Section 21,
- d) Crushing resistance per 23.1,
- e) Resistance to impact per 24.1 and 24.3,
- f) Dimensional change per 27.3,
- g) Abnormal operation per 28.1,
- h) Severe conditions per 29.1,
- i) Mold stress-relief distortion per 62.1,
- j) Input after mold stress-relief distortion per 31.1,
- k) Creep per Section 24A.
- l) Conduit connections per footnote h of Figure 6.1, and
- m) Thermal endurance per Sections 33 – 39.

6.11 effective until June 1, 2004

8 Mechanical/Electrical Property Considerations

8.1 General

8.1.1 Mechanical and electrical properties of materials are to be judged with respect to the particular “end use” application. The requirements in Mechanical/Electrical Property Considerations, Section 8, are intended to establish general minimum acceptable requirements for those applications where the polymeric material is relied upon to reduce the risks of fire and electric shock. In the case where the material’s characteristics do not meet the minimum performance levels specified, recommended engineering considerations will be made.

8.1.1 effective until June 1, 2004

8.1.2 These requirements do not cover the additional considerations that must be given to applications employing large masses of polymeric materials. Whether or not such materials protect against electric shock or injury to persons, consideration is to be given to the likelihood of ignition of the material by sources inside the product or by sources outside the product. See 21.1 for large mass flammability considerations.

8.1.2 effective until June 1, 2004

8.1.3 These requirements alone do not cover enclosures that provide mechanical support of electrically live parts. For evaluation of such enclosures, Figure 5.1 or 6.1 is to be used in addition to the requirements in Mechanical/Electrical Property Considerations, Section 8.

8.1.3 effective until June 1, 2004

8.1.4 Using Figure 8.1 as a guide, the figurative examples that match the application of the material under consideration determine the applicable properties tabulated in Table 8.1. A material shall provide acceptable levels of performance for each of these applicable properties tabulated in Table 8.1.

Exception: End product tests may be used to determine if the material is acceptable in the application, as indicated in Table 8.2.

8.1.4 effective until June 1, 2004

8.1.5 For example, a polymeric material used in an application that most closely matches figurative example No. 6 of Figure 8.1, would be evaluated with respect to the distortion under load and mold-stress relief, creep, and maximum-use temperature properties indicated in Table 8.1.

8.1.5 effective until June 1, 2004

8.1.6 To determine a polymeric material’s performance profile, certain tests are to be performed according to the methods contained in the Standard for Polymeric Materials – Short Term Property Evaluations, UL 746A and the Standard for Polymeric Materials – Long Term Property Evaluations, UL 746B. These tests, general engineering considerations, and minimum performance levels are tabulated in Table 8.1. Specific applications may require different limits than are shown in the general case. Refer to 8.2.1 and 8.2.2 for considerations to be used in determining the acceptability of an insulating material that does not meet with the requirements tabulated in Table 8.1.

8.1.6 effective until June 1, 2004

8.2 Performance weaknesses

8.2 effective until June 1, 2004

8.2.1 Some materials may have performance characteristics that are less than those tabulated in Table 8.1. In such cases, the application must be considered or special tests conducted to determine if the reduced value can be accepted without increasing the likelihood of risk for the particular end-product.

8.2.1 effective until June 1, 2004

8.2.2 Table 8.2 is intended to be used as a guide in determining the acceptability of a material where performance is less than the anticipated level.

8.2.2 effective until June 1, 2004

**Table 8.1
Mechanical/electrical property considerations**

Table 8.1 effective until June 1, 2004

Property	Test	Method	Units of PLC	Recommended levels related to flammability classification ^a				Applications ^b	Figurative examples from Fig. 8.1	Exceptions based upon engineering considerations
				V-0 VTM-0	V-1 VTM-1	V-2 VTM-2	HB			
Electric strength	Volume – resistivity	UL 746A	Min Ohm-cm (dry)	50 x 10 ⁶	50 x 10 ⁶	50 x 10 ⁶	50 x 10 ⁶	Material serves as insulation between uninsulated live parts of opposite polarity or between uninsulated live parts and (1) dead metal parts that may be grounded in service or (2) any surface exposed to contact	(1), (2), (3), (8)	See Sec. 16
			Min Ohm-cm (after 90% humidity)	10 x 10 ⁶	10 x 10 ⁶	10 x 10 ⁶	10 x 10 ⁶			
	Dielectric strength	UL 746A	Min V (rms) (both dry & after 90% humidity)	5000	5000	5000	5000	Same as above	(1), (2), (3), (8)	See Sec. 12
Tracking resistance	Comparative tracking index (CTI)	UL 746A	Max ^c PLC					Material surface is in contact with or in close proximity (less than 1/32 inch (0.8mm)) to (a) uninsulated live parts of opposite polarity, or (b) uninsulated live parts and either (1) dead metal parts that may be grounded in service, or (2) any surface exposed to contact	(2), (2), (4)	See Sec.11

Table 8.1 Continued on Next Page

Table 8.1 Continued

Property	Test	Method	Units of PLC	Recommended levels related to flammability classification ^a				Applications ^b	Figurate examples from Fig. 8.1	Exceptions based upon engineering considerations
				V-0 VTM-0	V-1 VTM-1	V-2 VTM-2	HB			
	CTI	UL 746A	Max ^c PLC	4	4	4	4	Higher CTI values are required where a greater degree of contamination is involved, as follows: Indoor equipment exposed to relatively clean environment		
				3	3	3	3	Outdoor and indoor equipment exposed to moderate contaminate environments		
				2	2	2	2	Outdoor and indoor equipment exposed to severe contaminate environments		
	Inclined-plane tracking	UL 746A	Min time (min) to track 25.4 mm at 2.5 kV excitation	60	60	60	60	Same as above for CTI except that the application voltage range is 601 V-5 kV	(2), (3), (4), (8)	See Sec. 15
				300	300	300	300	Same as above for CTI except that application voltage range 5,001 V-35 kV	(2), (3), (4), (8)	See Sec. 15
Permanence	Dimensional change after water exposure	UL 746A	Max percent change	2	2	2	2	Same as Volume Resistivity above but also includes applications where the material maintains the relative positioning of live parts and the parts could be subjected to high humidity or moisture	(1), (2), (3), (4), (7), (8)	See Sec. 27.2.1
Distortion under load	Heat deflection temperature under load or Vicat softening point or Ball pressure temperature	UL 746A	Min °C at 66 psi	10°C (18°F) greater than the use temperature but not less than 90°C				All applications except decorative parts	(1), (2), (3), (4), (5), (6), (7), (8)	See Sec. 30
				25°C greater than the use temperature but not less than 105°C (221°F)						
				Greater than the use temperature by the difference between 40°C and the ambient, but not less than 95°C						

Table 8.1 Continued on Next Page

Table 8.1 Continued

Property	Test	Method	Units of PLC	Recommended levels related to flammability classification ^a				Applications ^b	Figurative examples from Fig. 8.1	Exceptions based upon engineering considerations														
				V-0 VTM-0	V-1 VTM-1	V-2 VTM-2	HB																	
Dimensional Change due to External Stresses	Resistance to Creep	UL 746C		Resistance to creep should be evaluated in the specific application				All applications with mechanical stresses due to external sources	(1), (2), (3), (4), (5), (6), (7), (8)	See Sec. 24A														
Resistance to Electrical Ignition Sources	High current arc resistance to ignition (HAI)	UL 746A	Max PLC ^d	3	2	2	1	Material is in contact with or in close proximity to uninsulated live parts 0.8 mm (1/32 inch) for nonarcing parts or 12.7 mm (1/2 inch) for arcing parts	(1), (2), (3), (4), (5), (8)	See Sec. 13														
	Hot wire ignition HWI	UL 746A	Max PLC ^e	4	3	2	2	Material is in contact with or close proximity to uninsulated live parts [less than 0.8 mm (1/32 inch)]	(2), (3), (4), (8)	See Sec. 14														
Mechanical	Tensile or flexural strength; tensile, Izod, or Charpy impact	UL 746A	MPa KJ/m ² or J/m notch	Mechanical strength is judged in the application				Material maintains the relative positioning of live parts or encloses live parts	(2), (4), (7), (8)	See Sec. 24														
Maximum use temperature index (RTI)	Relative thermal	UL 746A	Minimum °C	The maximum operating temperature of the part shall not exceed materials' temperature limit determined by the method, indicated in Table 33.1 (See Sections 33 – 39)				All applications except decorative parts	(1), (2), (3), (4), (5), (6), (7), (8)	See Sec. 37 – 39														
<p>^a Materials classed as 5VA and 5VB only by the Vertical Burning Test described in the requirements for tests for flammability of plastic materials for parts in devices and appliances, UL 94, or a material when flame tested as used in the equipment, complies with the requirements in Flammability - 12 mm flame, Section 17, Flammability - 3/4-inch flame, Section 18, or Flammability - 127 mm (5 inch) flame, Section 19, shall be considered with respect to the recommended performance levels of a material classed as V-1</p> <p>^b Materials located in nonhazardous-energy circuitry, as defined in the appropriate end-product standard, shall only be considered with respect to their flammability, distortion under load and mold stress relief, mechanical and maximum use temperature properties except the resistance to electrical ignition sources property may also be considered if the material is located less than 12.7 (1/2 inch) from arcing parts or sources of ignition.</p> <p>^c</p> <table border="1" style="margin-left: 40px;"> <thead> <tr> <th>CT1 Range – Tracking Index (Volts)</th> <th>Assigned PLC</th> </tr> </thead> <tbody> <tr> <td>600 ≤ TI</td> <td>0</td> </tr> <tr> <td>400 ≤ TI < 600</td> <td>1</td> </tr> <tr> <td>250 ≤ TI < 400</td> <td>2</td> </tr> <tr> <td>175 ≤ TI < 250</td> <td>3</td> </tr> <tr> <td>100 ≤ TI < 175</td> <td>4</td> </tr> <tr> <td>0 ≤ TI < 100</td> <td>5</td> </tr> </tbody> </table>											CT1 Range – Tracking Index (Volts)	Assigned PLC	600 ≤ TI	0	400 ≤ TI < 600	1	250 ≤ TI < 400	2	175 ≤ TI < 250	3	100 ≤ TI < 175	4	0 ≤ TI < 100	5
CT1 Range – Tracking Index (Volts)	Assigned PLC																							
600 ≤ TI	0																							
400 ≤ TI < 600	1																							
250 ≤ TI < 400	2																							
175 ≤ TI < 250	3																							
100 ≤ TI < 175	4																							
0 ≤ TI < 100	5																							

Table 8.1 Continued

Property	Test	Method	Units of PLC	Recommended levels related to flammability classification ^a				Applications ^b	Figurative examples from Fig. 8.1	Exceptions based upon engineering considerations
				V-0 VTM-0	V-1 VTM-1	V-2 VTM-2	HB			
^d During the HAI test, the electrodes are to be positioned as indicated in 13.2										
				HAI Range – mean number of arcs to cause ignition		Assigned PLC				
				120 ≤ NA		0				
				60 ≤ NA < 120		1				
				30 ≤ NA < 60		2				
				15 ≤ NA < 30		3				
				0 ≤ NA < 15		4				
				HWI Range – mean ignition time		Assigned PLC				
				120 ≤ IT		0				
				60 ≤ IT < 120		1				
				30 ≤ IT < 60		2				
				15 ≤ IT < 30		3				
				7 ≤ IT < 15		4				
				0 ≤ IT < 7		5				

Table 8.2
Additional considerations for performance weaknesses

Table 8.2 effective until June 1, 2004

Test	Additional end product considerations
1. Volume resistivity	Conduct end product leakage current test – see 16.1
2. Dielectric strength	Use thicker material section – see 12.1
3. Comparative tracking index (CTI)	Increase spacings
4. Inclined Plane tracking	Increase spacings
5. Permanence	Conduct end product conditioning test – see 27.2
6. Distortion under load	Conduct end product mold stress-relief distortion test where stress is internal (i.e. results from molding or fabrication process) – see 30.1 Conduct end-product creep test where stress is due to externally applied forces – see Section 24A
7. High current arc ignition (HAI)	Conduct end product arc resistance test – see 13.3 and 13.4
8. Hot wire ignition (HWI)	Conduct end product abnormal overload test, or end-product Glow-Wire Test – see Hot-Wire Ignition (HWI) – Abnormal Overload Test, Section 14
9. Maximum Use Temperature	Conduct end product thermal aging test – see Relative Thermal Index, Section 36, Relative Thermal Capability, Section 37, and Temperature Excursions Beyond the Maximum Use Temperature, Section 39

9 Internal Barriers

9.1 A vulcanized fiber barrier or liner having a minimum 0.71 mm (0.028 inch) thickness may be an acceptable alternative to maintaining electrical spacing between live parts of opposite polarity or between uninsulated live parts and accessible metal parts where the maximum temperature does not exceed 90°C (194°F).

Exception No. 1: 0.33 mm (0.013 inch) thick vulcanized fiber is acceptable if used in conjunction with an air space of at least one-half of the required spacing.

9.1 effective until June 1, 2004

9.2 A barrier or liner of other than vulcanized fiber, employed where spacings are unacceptable between uninsulated live parts of opposite polarity or between uninsulated live parts and accessible metal parts, shall comply with all of the following:

- a) The barrier or liner shall be of insulating material that complies with Table .
- b) The minimum thickness of the barrier or liner shall be at least 0.71 mm (0.028 inch), except that 0.33 mm (0.013 inch) is acceptable where used in conjunction with an air space of at least one-half of the required spacing.

Exception: The thickness of the barrier may be less than that specified in providing that the results of a separate investigation indicate acceptable performance. For example, 0.18 mm (0.007 inch) thick polyethylene terephthalate (PETP) film is considered equivalent to 0.71 mm (0.028 inch) thick vulcanized fiber. Resin bonded mica 0.15 mm (0.006 inch) thick is considered electrically equivalent to 0.71 mm (0.028 inch) thick vulcanized fiber; however, its use is limited to applications where it is protected from mechanical abuse or movement.

- c) The barrier or liner shall be equivalent to vulcanized fiber in mechanical strength (tensile strength, tear resistance, puncture strength, creep, and the like) if likely to be subject to mechanical damage. See Polymeric Materials – Industrial Laminates, Filament Wound Tubing, Vulcanized Fibre, and Materials used in Printed Wiring Boards, UL 746E, Vulcanized Fibre, Section 9, for specific performance indexing data on vulcanized fiber.
- d) The maximum use temperature shall not exceed either the Functional-Use Temperature Indices, Section , Generic Thermal Indices, Section , or the Relative Thermal Index, Section , of the barrier material, unless an end-product relative thermal capability evaluation is conducted using the requirements of Relative Thermal Capability, Section .

9.2 effective until June 1, 2004

Table 9.1
Material requirements for internal barriers

Table 9.1 effective until June 1, 2004

Application	Properties				
	Resistance to ignition from		Flammability classification ^d	Comparative tracking index (CTI) max. PLC ^e	Other criteria ^f
	Hot-wire (HWI) max. PLC ^b	High-current arc (HAI) max. PLC ^c			
Used instead of spacings in contact with live parts	4 or g 3 or g 2 or g	3 2 2	V-0 or VTM-0 V-1 or VTM-1 V-2 or VTM-2	e, o e, o e, o	i, j, k, l, m, n i, j, k, l, m, n i, j, k, l, m, n
Used instead of spacings in conjunction with an air space	4 or g 3 or g 2 or g 2 or g	3 ^h 2 ^h 2 ^h 1 ^h	V-0 or VTM-0 V-1 or VTM-1 V-2 or VTM-2 HB	4 4 4 4	i, k i, k i, k i, k
Used as a physical barrier only	– 2 or g	– 1 ^h	V-0 or VTM-0 or V-1 or VTM-1 or V-2 or VTM-2 or HB	– –	k k

^a Deleted.

^b Hot-Wire Resistance to Ignition – See 3.18.

^c High-Current Arc Resistance to Ignition – See 3.17.

^d Flammability Classification – See 3.13.

^e Comparative Tracking Index – See 3.5 and Comparative Tracking Index (CTI), Section 11.

^f Other criteria; mechanical strength is to be judged in the application. Special consideration is to be given to cold flow or creep characteristics if the barrier material is subjected to any type of long-time mechanical loading (for example, bending, compressive, or tensile loading). See section 24A.

^g Abnormal Overload Test or End-Product Glow-wire Test described in Section 14.

^h Material evaluated with test electrodes positioned as indicated in 13.2. Test is not required if:

a) An arcing part is located 12.7 mm (1/2 inch) or more from the material, or

b) A nonarcing live part (bus bar, terminal, and the like) is located 0.8 mm (1/32 inch) or more from the material.

ⁱ Dielectric Breakdown Strength – The barrier material shall comply with the dielectric strength criteria specified in 12.1.

^j Volume Resistivity – The barrier material shall comply with the volume resistivity criteria specified in Section 16.

^k Mold-Stress Relief – The barrier material shall comply with the mold-stress relief distortion criteria specified in Sections 30 and 62 upon completion of the test described in 62.1.
This test is not required for rigid thermosetting material.

Table 9.1 Continued on Next Page

Table 9.1 Continued

Application	Properties				
	Resistance to ignition from		Flammability classification ^d	Comparative tracking index (CTI) max. PLC ^e	Other criteria ^f
	Hot-wire (HWI) max. PLC ^b	High-current arc (HAI) max. PLC ^c			
<p>^l Creep – Parts subject to mechanical stresses from internal or external sources (such as bending, compressive or tensile loading) are required to withstand the test described in Section 24A. There is to be no warpage or distortion that:</p> <ul style="list-style-type: none"> a) Interferes with normal operation or servicing, b) Results in accessibility of live parts, or c) Reduces electrical spacings below the level necessary to comply with the applicable requirements pertaining to dielectric strength and leakage current <p>This test is not required for rigid thermosets.</p> <p>^m UV Resistance – The barrier material shall comply with the applicable UV and water immersion requirements in Section 26.</p> <p>ⁿ Water Exposure and Immersion (For Equipment Intended for Outdoor Use) – The barrier material shall comply with the applicable water immersion and dimensional change criteria specified in Section 27.</p> <p>^o For a barrier in contact with electrically live parts, a maximum CTI PLC of 4 is required for indoor equipment in a relatively clean environment. Higher CTI values would be required where a greater degree of contamination and/or potentials are involved, as indicated in Table 8.1 and Comparative Tracking Index (CTI), Section 11.</p>					

9.3 A material, that is used as a physical barrier against contact with parts that can cause injury to persons during intended use, cleaning, servicing, or to restrict access to circuitry where there is an increased risk of electric shock, shall comply with the requirements in 9.2.

9.3 effective until June 1, 2004

10.1 Section 10 – 39 indicated the test methods and minimum performance levels specified in part 2 of Figures 5.1, 6.1 and Table 8.1. Some materials may not comply with all of the general properties required for the application. In such cases, the application must be further considered to determine if the material's characteristics are not acceptable, or if a reduced value can be accepted without increasing the likelihood of risk for the particular end-product.

10.1 effective until June 1, 2004

14.3 Glow-wire end-product test

A Alternate Enclosure Material Considerations

A.2 It may not be necessary that a complete series of end-product tests be required, provided that equivalent or better material properties can be demonstrated by standardized small-scale tests on the candidate material when compared to the properties of a material having acceptable application performance.

Exception: A candidate material that does not provide equivalent material properties to the properties of a material having acceptable application performance, may be acceptable providing that the candidate material possesses the minimum performance level required in Figure 5.1 or 6.1 and/or Table 8.1 for the application.

**Table A.1
Alternative material consideration**

Material property parameters (Column 1)	Candidate material characteristics, equivalent or better than characteristics of the original material considered acceptable for the application (Column 2)	Candidate material characteristics, equivalent or better than those required for the application (Column 3)	Candidate material characteristics not equivalent to original material characteristics nor meets those required for the application (Column 4)
FLAMMABILITY (flammability classification at use thickness and color)	Candidate Material Considered Acceptable	Candidate Material Considered Acceptable	Conduct flame test on part or enclosure (See Flammability – 12 mm Flame, Section 17, Flammability – 127 mm (5 inch) Flame, Section 19, Enclosure Flammability – Large Mass Considerations, Section 21)
ELECTRIC STRENGTH (1) Volume resistivity (2) Dielectric Strength	Candidate Material Considered Acceptable	Candidate Material Considered Acceptable	Conduct end-product (1) leakage current tests or insulation resistance complying with 16.3 (2) dielectric withstand complying 12.1
TRACKING RESISTANCE (1) Comparative tracking index or (2) Inclined Plane Tracking	Candidate Material Considered Acceptable	Candidate Material Considered Acceptable	(1) Increase spacings to $\geq \frac{1}{2}$ in. (2) Increase spacings to: Refer to applicable end-product considerations.
WATER RESISTANCE (1) Dimensional change after water exposure (2) Properties after water immersion (Outdoor use only) Also see A.4	Candidate Material Considered Acceptable	Candidate Material Considered Acceptable	Conduct end-product Humidity/immersion tests per 27.2 Material is not suitable for prolonged exposure to water
ULTRA-VIOLET RESISTANCE Properties after ultra-violet exposure. (Outdoor use only) Also see A.4	Candidate Material Considered Acceptable	Candidate Material Considered Acceptable	Material is not suitable for exposure to weather
RESISTANCE TO ELECTRICAL IGNITION (1) Hot- wire ignition and flame classification combination, (2) High current arc resistance and flame classification combination	Candidate Material Considered Acceptable	Candidate Material Considered Acceptable	Conduct end-product: Abnormal Overload Test or Glow Wire Test per section 14 Arc-Resistance Test per par. 13.3 – 13.5
MECHANICAL (See note b)	Candidate Material Considered Acceptable ^a	NA	Conduct end-product

Table A.1 Continued on Next Page

Table A.1 Continued

Material property parameters (Column 1)	Candidate material characteristics, equivalent or better than characteristics of the original material considered acceptable for the application (Column 2)	Candidate material characteristics, equivalent or better than those required for the application (Column 3)	Candidate material characteristics not equivalent to original material characteristics nor meets those required for the application (Column 4)
(1) Tensile or Flexural Strength (2) Tensile or Izod impact or Charpy			(1) Crushing Resistance per 23.1 and Strain Relief per 32.1 or Conduit tests per UL 50 or UL 508 (2) Impact Resistance per Sec. 24 and Strain Relief per 32.1 or Conduit tests per UL 50 or UL 508
DEFORMATION (See notes a) (1) Heat Deflection (2) Creep	Candidate Material Considered Acceptable ^a	NA	Conduct end-product Mold Stress-Relief test. Test is not required for thermoset materials. All alternative or substitute materials are to be subjected to end product creep tests (see Section 24A) unless: a) The candidate material is of the same composition b) The candidate has equivalent of higher small-scale heat deflection, vicat softening, or ball pressure temperature indices. c) The candidate has equivalent creepage characteristics based on tests and/or test data (Note - the test results being compared must have the same test parameters) Creep evaluations are not required for rigid thermoset materials.
MAXIMUM USE TEMPERATURE	Refer to Sections 33 – 39		
SPECIAL END-USE CONSIDERATIONS^b	If indicated by the applicable path in Figure 5.1 or 6.1, all alternative or substitute materials are to be subjected to the abnormal operation (28.1) and severe conditions tests (29.1), unless the candidate is of the same generic type with the same percentage and type of fillers, reinforcements, heat stabilizers and flame retardants.		

Table A.1 Continued

Material property parameters (Column 1)	Candidate material characteristics, equivalent or better than characteristics of the original material considered acceptable for the application (Column 2)	Candidate material characteristics, equivalent or better than those required for the application (Column 3)	Candidate material characteristics not equivalent to original material characteristics nor meets those required for the application (Column 4)
<p>^a All alternative or substitute materials are to be subjected to end-product impact, crush, conduit, strain relief and mold stress-relief tests unless:</p> <ol style="list-style-type: none"> 1) The candidate material is of the same generic type with the same percentage and type of fillers and reinforcements, and 2) The candidate material has equivalent or higher small-scale tensile or flexural strength, tensile or izod impact and heat deflection ratings indicated above. <p>^b See A.4</p>			