

LI-ION/POLYMER ONE CELL PROTECTOR

DESCRIPTION

The EUP9261 series are lithium-ion/lithium polymer rechargeable battery protection ICs incorporating high-accuracy voltage detection circuit and delay circuit. The EUP9261 series are suitable for protection of single-cell lithium-ion/lithium polymer battery packs from overcharge, overdischarge and overcurrent.

FEATURES

- Absolute maximum rating of 30V for the charger connection pins (VM and CO)
- Highly accurate voltage detector.....

Overcharge detection (Topt=+25°C)	±25mV
(Topt=-5 to 55°C)	±30mV
Overcharge hysteresis	±25mV
Overdischarge detection	±50mV
Overcurrent 1 detection	±15mV
Overcurrent 2 detection	±100mV
- Variety of detector.....

Overcharge detection	3.9V-4.4V step of 5mV
Overcharge hysteresis	0.0V-0.4V* ¹ step of 50mV
Overdischarge detection	2.0V-3.0V step of 10mV
Overdischarge hysteresis	0.0V-0.7V* ² step of 100mV
Overcurrent 1 detection	0.03V-0.3V step of 10mV
Overcurrent 2 detection	0.5V

*1 Overcharge release voltage=Over detection voltage-Overcharge hysteresis voltage

*2 Overdischarge release voltage = Overdischarge detection voltage-Overdischarge hysteresis voltage.

- Delay times internally generated. Accuracy : ±30%.
(overcharge: t_{CU} , overdischarge: t_{DL} , overcurrent 1: t_{IOV1} , overcurrent 2: t_{IOV2})
- Three-step overcurrent detection circuit is included.(overcurrent 1,overcurrent 2 and load short – circuiting)
- Charger detection function and abnormal charge current detection function, included.
- 0V-battery charge option: Acceptable/Unacceptable.
- Low current consumption
 - Operation: 3.0µA typ. 6µA max.
 - Power-down 0.1µA max.
- DP pin.....At V_{SS} level, delay circuit is disabled. Tie a 300kΩ resistor to V_{SS} , delay time of all items expect short-circuit can be reduced.
- Wide operating temperature range: -40°C to + 85°C.
- Small package: SOT-23-6
- RoHS compliant and 100% lead (Pb)-free

APPLICATIONS

- Lithium-ion rechargeable battery packs.
- Lithium polymer rechargeable battery packs.

Block Diagram

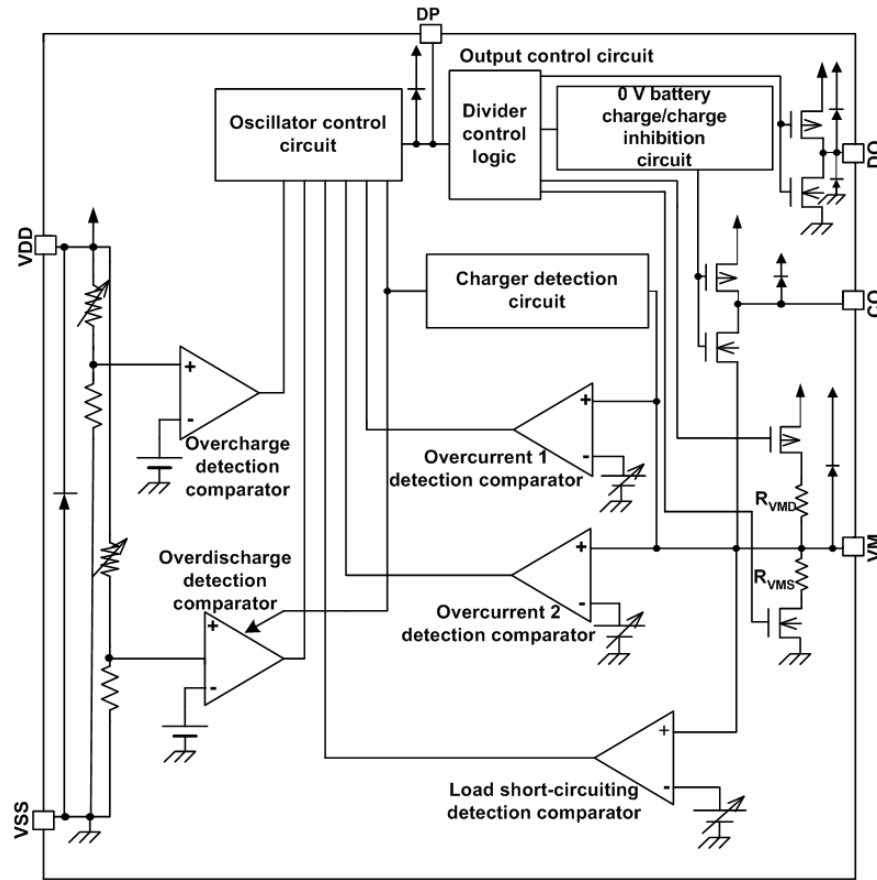

Figure1.

Pin Configurations

Part Number	Pin Configurations
EUP 9261 SOT-23-6	

Pin Description

PIN	PIN	DESCRIPTION
DO	1	DO FET gate control pin for discharge (CMOS output)
VM	2	VM Voltage detection pin between VM and VSS (Overcurrent detection pin)
CO	3	CO FET gate control pin for charge(CMOS output)
DP	4	Pin for reduce output delay time and for delay time measurement
VDD	5	VDD Positive power input pin
VSS	6	VSS Negative power input pin

Absolute Maximum Ratings

- Input voltage between V_{DD} and V_{SS} ----- $V_{SS} - 0.3\text{ V}$ to $V_{SS} + 12\text{ V}$
- Input pin voltage for VM ----- $V_{DD} - 30\text{ V}$ to $V_{DD} + 0.3\text{ V}$
- Output pin voltage for CO ----- $V_{VM} - 0.3\text{ V}$ to $V_{DD} + 0.3\text{ V}$
- Output pin voltage for DO ----- $V_{SS} - 0.3\text{ V}$ to $V_{DD} + 0.3\text{ V}$
- Power dissipation SOT-23-6 ----- 250mW
- Operating temperature range ----- -40°C to $+85^{\circ}\text{C}$
- Storage temperature range ----- -55°C to $+125^{\circ}\text{C}$
- ESD Susceptibility
 - HBM (Human Body Mode) ----- $>1\text{KV}$
 - MM (Machine Mode) ----- $>200\text{V}$

Ordering Information

Order Number	Package Type	Marking	Operating Temperature range
EUP9261AJAIR1	SOT-23-6	BJ	-40°C to 85°C
EUP9261AJAIR0	SOT-23-6	BJ	-40°C to 85°C
EUP9261BJAIR1	SOT-23-6	BT	-40°C to 85°C
EUP9261BJAIR0	SOT-23-6	BT	-40°C to 85°C
EUP9261BOAIR1	SOT-23-6	BO	-40°C to 85°C
EUP9261BOAIR0	SOT-23-6	BO	-40°C to 85°C
EUP9261BQAIR1	SOT-23-6	BQ	-40°C to 85°C
EUP9261BQAIR0	SOT-23-6	BQ	-40°C to 85°C
EUP9261BPAIR1	SOT-23-6	BP	-40°C to 85°C
EUP9261BPAIR0	SOT-23-6	BP	-40°C to 85°C
EUP9261BBAIR1	SOT-23-6	BB	-40°C to 85°C
EUP9261BBAIR0	SOT-23-6	BB	-40°C to 85°C

EUP9261

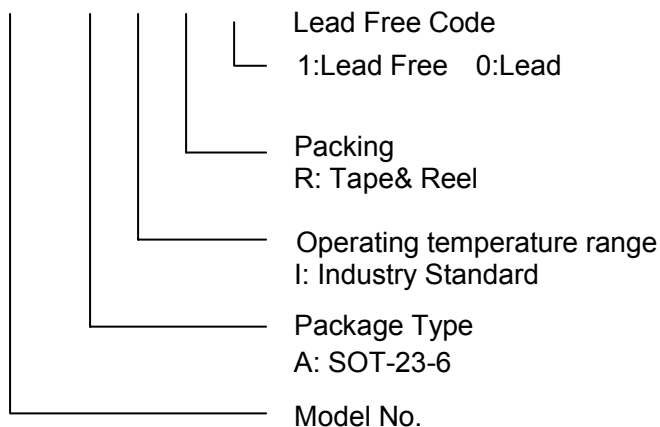

Application Circuit

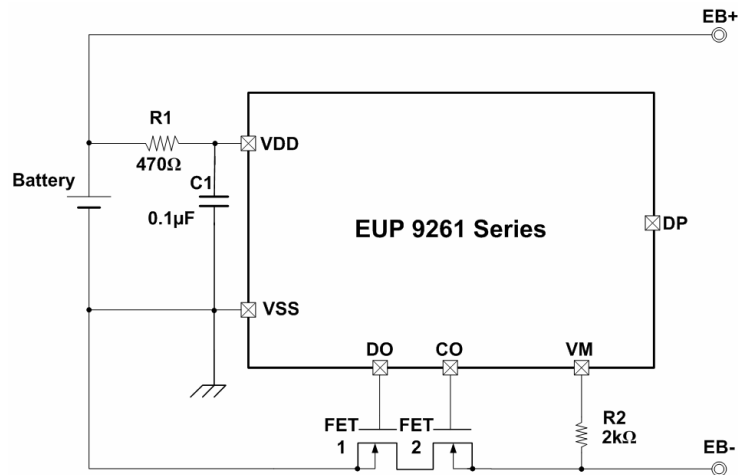

Figure2.

Product name list

Model No.	Overcharge detection voltage[V _{CU}]	Overcharge Hysteresis voltage[V _{HC}]	Overdischarge detection voltage [V _{DL}]	Overdischarge hysteresis voltage [V _{HD}]	Overcurrent 1 detection voltage [V _{IOV1}]	0V battery charge function
EUP9261AJ	4.325 V	0.25V	2.5V	0.4V	0.150V	Unavailable
EUP9261BJ	4.28	0.2V	3.0V	0V	0.080V	Available
EUP9261BO	4.28	0.2V	2.3V	0V	0.040V	Available
EUP9261BQ	4.28	0.2V	2.9V	0.1V	0.030V	Available
EUP9261BP	4.35	0.2V	2.3V	0.7V	0.200V	Available
EUP9261BB	4.28	0.3V	2.3V	0.1V	0.125V	Available

Model No.	Overcharge detection delay time	Overdischarge detection delay time	Overcurrent 1 detection delay time	Delay time combination
EUP9261AJ	1.2s	144ms	9ms	(I)
EUP9261BJ	1.2s	144ms	9ms	
EUP9261BO	1.2s	144ms	9ms	
EUP9261BQ	1.2s	144ms	9ms	
EUP9261BP	125ms	31ms	16ms	(II)
EUP9261BB	125ms	31ms	16ms	

Note: It is possible to change the detection voltages of the product other than above. The delay times can also be changed within the range listed below. For details, please contact our sales office.

Delay time combination

Select the delay time combination for an internal 3.5 kHz clock generator (I)

Delay time	Symbol	Selection range			Note
Overcharge detection delay time	t _{CU}	0.15 s	1.2 s	4.6 s	Choose from the left.
Overdischarge detection delay time	t _{DL}	36 ms	144 ms	290 ms	Choose from the left.
Overcurrent 1 detection delay time	t _{IOV1}	4.5 ms	9 ms	18 ms	Choose from the left.

Select the delay time combination for an internal 4 kHz clock generator (II)

Delay time	Symbol	Selection range			Note
Overcharge detection delay time	t _{CU}	0.125 s	0.5 s	1.0 s	Choose from the left.
Overdischarge detection delay time	t _{DL}	31 ms	62.5 ms	125 ms	Choose from the left.
Overcurrent 1 detection delay time	t _{IOV1}	4 ms	8 ms	16 ms	Choose from the left.

Note: Values surrounded by bold lines are used in standard products

Electrical Characteristics (1) Except detection delay time (25°C)

(Ta=25°C unless otherwise specified)

Symbol	Parameter	Remark	Min	Typ	Max	Unit	Measurement circuit
Detection Voltage							
V _{CU}	Overcharge detection voltage V _{CU} =3.9 V to 4.4 V, 5 mV Step	-----	V _{CU} -0.025	V _{CU}	V _{CU} +0.025	V	1
		Ta = -5°C to 55°C*1	V _{CU} -0.030	V _{CU}	V _{CU} +0.030		
V _{HC}	Overcharge hysteresis voltage V _{HC} =0.0V to 0.4V, 50mV Step	-----	V _{HC} -0.025	V _{HC}	V _{HC} +0.025	V	1
V _{DL}	Overdischarge detection voltage V _{DL} =2.0 V to 3.0 V, 10 mV Step	-----	V _{DL} -0.050	V _{DL}	V _{DL} +0.050	V	2
V _{HD}	Overdischarge hysteresis voltage V _{HD} =0.0V to 0.7V, 100mV Step	-----	V _{HD} -0.050	V _{HD}	V _{HD} +0.050	V	2
V _{IOV1}	Overcurrent 1 detection voltage V _{IOV1} =0.05V to 0.3V, 10mV Step	-----	V _{IOV1} -0.015	V _{IOV1}	V _{IOV1} +0.015	V	2
V _{IOV2}	Overcurrent 2 detection voltage	-----	0.4	0.5	0.6	V	2
V _{SHORT}	Load short-circuiting detection voltage	AJ, BJ, BO, BQ	0.9	1.2	1.5	V	2
		BP, BB	V _{DD} -1.7	V _{DD} -1.3	V _{DD} -0.9	V	2
V _{CHA}	Charge detection voltage	AJ, BJ, BO, BQ	-1.0	-0.7	-0.4	V	2
		BP, BB	-1.7	-1.3	-0.9	V	2
Input Voltage, Operation Voltage							
V _{DSOP1}	Operation voltage between V _{DD} and V _{SS}	Internal circuit operating voltage	1.5	--	8	V	---
V _{DSOP2}	Operation voltage between V _{DD} and V _M	Internal circuit operating voltage	1.5	--	28	V	---
Current Consumption							
I _{OPE}	Current consumption in normal operation	V _{DD} =3.5 V, V _{VM} =0 V	1.0	3.0	6.0	μA	2
I _{PDN}	Current consumption at power down	V _{DD} =V _{VM} =1.5 V	--	--	0.1	μA	2
Output Resistance							
R _{COH}	CO pin H resistance	V _{CO} =3.0V, V _{DD} =3.5V V _{VM} =0 V	2.5	5	10	kΩ	4
R _{COL}	CO pin L resistance	V _{CO} =0.5 V, V _{DD} = 4.5V, V _{VM} =0 V	2.5	5	10	kΩ	4
R _{DOH}	DO pin H resistance	V _{DO} =3.0 V, V _{DD} =3.5V, V _{VM} =0 V	2.5	5	10	kΩ	4
R _{DOL}	DO pin L resistance	V _{DO} =0.5V V _{DD} =V _{VM} =1.8 V	2.5	5	10	kΩ	4
VM Internal Resistance							
R _{VMD}	Internal resistance between VM and VDD	V _{DD} =1.8 V, V _{VM} =0 V	100	300	900	kΩ	3
R _{VMS}	Internal resistance between VM and VSS	V _{DD} =3.5 V, V _{VM} =1.0 V	15	35	60	kΩ	3
0V battery charging function							
V _{0CHA}	0V battery charge starting charger voltage	0V battery charging available	1.2	--	--	V	2
V _{0INH}	0V battery charge inhibition battery voltage	0V battery charging unavailable	--	--	0.5	V	2

*1. Since products are not screened at low and high temperature, the specification for this temperature range is guaranteed by design not tested in production.

Electrical Characteristics (2) Except detection delay time (-40°C to +85°C*1)

(Ta= -40°C to +85°C*1 unless otherwise specified)

Symbol	Parameter	Remark	Min	Typ	Max	Unit	Measurement circuit
Detection Voltage							
V _{CU}	Overcharge detection voltage V _{CU} =3.9 V to 4.4 V, 5 mV Step	-----	V _{CU} -0.055	V _{CU}	V _{CU} +0.040	V	1
V _{HC}	Overcharge hysteresis voltage V _{HC} =0.0V to 0.4V, 50mV Step	-----	V _{HC} -0.030	V _{HC}	V _{HC} +0.030	V	1
V _{DL}	Overdischarge detection voltage V _{DL} =2.0 V to 3.0 V, 10 mV Step	-----	V _{DL} -0.080	V _{DL}	V _{DL} +0.080	V	2
V _{HD}	Overdischarge hysteresis voltage V _{HD} =0.0V to 0.7V, 100mV Step	-----	V _{HD} -0.050	V _{HD}	V _{HD} +0.050	V	2
V _{IOV1}	Overcurrent 1 detection voltage V _{IOV1} =0.05V to 0.3V, 10mV Step	-----	V _{IOV1} -0.025	V _{IOV1}	V _{IOV1} +0.025	V	2
V _{IOV2}	Overcurrent 2 detection voltage	-----	0.37	0.5	0.63	V	2
V _{SHORT}	Load short-circuiting detection voltage	AJ, BJ, BO, BQ	0.7	1.2	1.7	V	2
		BB, BP	V _{DD} -1.9	V _{DD} -1.3	V _{DD} -0.7	V	2
V _{CHA}	Charge detection voltage	AJ, BJ, BO, BQ	-1.2	-0.7	-0.2	V	2
		BB, BP	-2.2	-1.3	-0.4		
Input Voltage, Operation Voltage							
V _{DSOP1}	Operation voltage between V _{DD} and V _{SS}	Internal circuit operating voltage	1.5	--	8	V	---
V _{DSOP2}	Operation voltage between V _{DD} and V _M	Internal circuit operating voltage	1.5	--	28	V	---
Current Consumption							
I _{OPE}	Current consumption in normal operation	V _{DD} =3.5 V, V _{VM} = 0 V	0.7	3.0	8.0	μA	2
I _{PDN}	Current consumption at power down	V _{DD} =V, V _{VM} =1.5 V	--	--	0.1	μA	2
Output Resistance							
R _{COH}	CO pin H resistance	V _{CO} = 3.0 V, V _{DD} =3.5V, V _{VM} = 0 V	1.2	5	15	kΩ	4
R _{COL}	CO pin L resistance	V _{CO} =0.5 V, V _{DD} =4.5V, V _{VM} = 0 V	3	10	20	kΩ	4
R _{DOH}	DO pin H resistance	V _{DO} =3.0 V, V _{DD} =3.5V, V _{VM} = 0 V	1.2	5	15	kΩ	4
R _{DOL}	DO pin L resistance	V _{DO} =0.5V, V _{DD} =V _{VM} = 1.8V	1.2	5	15	kΩ	4
VM internal resistance							
R _{VMD}	Internal resistance between V _M and V _{DD}	V _{DD} =1.8 V, V _{VM} =0 V	78	300	1310	kΩ	3
R _{VMS}	Internal resistance between V _M and V _{SS}	V _{DD} =3.5 V, V _{VM} =1.0 V	10	35	70	kΩ	3
0V battery charging function							
V _{0CHA}	0V battery charge starting charger voltage	0V battery charging available	1.7	--	--	V	2
V _{0INH}	0V battery charge inhibition battery voltage	0V battery charging unavailable	--	--	0.3	V	2

*1.Since products are not screened at low and high temperature, the specification for this temperature range is guaranteed by design, no tested in production.

Electrical Characteristics (3) Detection delay time**(I) EUP9261 AJ, EUP9261BJ, EUP9261BO, EUP9261BQ**

Symbol	Parameter	Remark	Min.	Typ.	Max.	Unit	Measurement circuit
Delay time (25°C)							
t_{CU}	Overcharge detection delay time	-----	0.84	1.2	1.56	s	5
t_{DL}	Overdischarge detection delay time	-----	100	144	188	ms	5
t_{IOV1}	Overcurrent 1 detection delay time	-----	6.3	9	11.7	ms	5
t_{IOV2}	Overcurrent 2 detection delay time	-----	2.1	3	3.9	ms	5
t_{SHORT}	Load short-circuiting detection delay time	-----	200	320	500	μs	5
Delay time (-40°C to +85°C) *1							
t_{CU}	Overcharge detection delay time	-----	0.7	1.2	2.0	ms	5
t_{DL}	Overdischarge detection delay time	-----	80	144	245	ms	5
t_{IOV1}	Overcurrent 1 detection delay time	-----	5	9	15	ms	5
t_{IOV2}	Overcurrent 2 detection delay time	-----	1.5	3	5	ms	5
t_{SHORT}	Load short-circuiting detection delay time	-----	150	320	600	μs	5

(II) EUP9261BB, EUP9261BP

Symbol	Parameter	Remark	Min.	Typ.	Max.	Unit	Measurement circuit
Delay time (25°C)							
t_{CU}	Overcharge detection delay time	-----	87.5	125	162.5	ms	5
t_{DL}	Overdischarge detection delay time	-----	21	31	41	ms	5
t_{IOV1}	Overcurrent 1 detection delay time	-----	11	16	21	ms	5
t_{IOV2}	Overcurrent 2 detection delay time	-----	2.1	3	3.9	ms	5
t_{SHORT}	Load short-circuiting detection delay time	-----	200	320	500	μs	5
Delay time (-40°C to +85°C) *1							
t_{CU}	Overcharge detection delay time	-----	69	125	212	ms	5
t_{DL}	Overdischarge detection delay time	-----	17	31	53	ms	5
t_{IOV1}	Overcurrent 1 detection delay time	-----	9	16	27	ms	5
t_{IOV2}	Overcurrent 2 detection delay time	-----	1.5	3	5	ms	5
t_{SHORT}	Load short-circuiting detection delay time	-----	150	320	600	μs	5

Measurement Circuits

Unless otherwise specified, the output voltage levels “L” and “H” at CO and DO pins are judged by the threshold voltage (1.0 V) of the N channel FET. Judge the CO pin level with respect to V_{VM} and the DO pin level with respect to V_{SS} .

(1) Measurement Condition 1, Measurement Circuit 1

<Overcharge detection voltage, Overcharge hysteresis voltage.>

The overcharge detection voltage (V_{CU}) is defined by the voltage between VDD and VSS at which V_{CO} goes “L” from “H” when the voltage V_1 is gradually increased from the starting condition $V_1=3.5V$. The overcharge hysteresis voltage (V_{HC}) is then defined by the difference between the overcharge detection voltage (V_{CU}) and the voltage between VDD and VSS at which V_{CO} goes “H” from “L” when the voltage V_1 is gradually decreased.

(2) Measurement Condition 2, Measurement Circuit 2

<Overdischarge detection voltage, Overdischarge hysteresis voltage >

The overdischarge detection voltage (V_{DL}) is defined by the voltage between VDD and VSS at which V_{DO} goes “L” from “H” when the voltage V_1 is gradually decreased from the starting condition $V_1=3.5V$ and $V_2=0V$. The overdischarge hysteresis voltage (V_{HD}) is then defined by the difference between the overdischarge detection voltage (V_{DL}) and the voltage between VDD and VSS at which V_{DO} goes “H” from “L” when the voltage V_1 is gradually increased.

(3) Measurement Condition 3, Measurement Circuit 2

<Overcurrent 1 detection voltage, Overcurrent 2 detection voltage, Load short-circuiting detection voltage.>

The overcurrent 1 detection voltage (V_{IOV1}) is defined by the voltage between VM and VSS at which V_{DO} goes “L” from “H” when the voltage V_2 is gradually increased from the normal condition $V_1=3.5V$ and $V_2=0V$.

The overcurrent 2 detection voltage (V_{IOV2}) is defined by the voltage between VM and VSS at which V_{DO} goes “L” from “H” when the voltage V_2 is increased at the speed between 1ms and 4ms from the normal condition $V_1=3.5V$ and $V_2=0V$.

The load short-circuiting detection voltage (V_{SHORT}) is defined by the voltage between VDD and VSS at which V_{DO} goes “L” from “H” when the voltage V_2 is increased at the speed between 1 μ s and 50 μ s from the normal condition $V_1=3.5V$ and $V_2=0V$.

(4) Measurement Condition 4, Measurement Circuit 2

<Charger detection voltage, abnormal charge current detection voltage.>

Set $V_1=1.8V$ and $V_2=0V$. Increase V_1 gradually until $V_1=V_{DL}+(V_{HD}/2)$, then decrease V_2 from 0V gradually. The voltage between VM and VSS when V_{DO} goes “H” from “L” is the charger detection voltage (V_{CHA}). Charger detection voltage can be measured only in the product whose overdischarge hysteresis $V_{HD} \neq 0$.

Set $V_1=3.5V$ and $V_2=0V$. Decrease V_2 from 0V gradually. The voltage between VM and VSS when V_{CO} goes “L” from “H” is the abnormal charge current detection voltage. The abnormal charge current detection voltage has the same value as the charger detection voltage (V_{CHA}).

(5) Measurement Condition 5, Measurement Circuit 2

<Normal operation current consumption, Power-down current consumption.>

Set $V_1=3.5V$ and $V_2=0V$ under normal condition. The current I_{DD} flowing through VDD pin is the normal operation consumption current (I_{OPE}). Set $V_1=V_2=1.5V$ under overdischarge condition. The current I_{DD} flowing through VDD pin is the power-down current consumption (I_{PDN}).

(6) Measurement Condition 6, Measurement Circuit 3

< Internal resistance between VM and VDD, Internal resistance between VM and VSS. >

Set $V_1=1.8V$ and $V_2=0V$. The resistance between VM and VDD is the internal resistance (R_{VMD}) between VM and VDD. Set $V_1=3.5V$ and $V_2=1.0V$. The resistance between VM and VSS is the internal resistance (R_{VMS}) between VM and VSS.

(7) Measurement Condition 7, Measurement Circuit 4

<CO pin H resistance, CO pin L resistance>

Set $V_1=3.5V$, $V_2=0V$ and $V_3=3.0V$. CO pin resistance is the CO pin H resistance (R_{COH}). Set $V_1=4.5V$, $V_2=0V$ and $V_3=0.5V$. CO pin resistance is the CO pin L resistance (R_{COL}).

(8) Measurement Condition 8, Measurement Circuit 4

<DO pin H resistance, DO pin L resistance.>

Set $V_1=3.5V$, $V_2=0V$ and $V_4=3.0V$. DO pin resistance is the DO pin H resistance (R_{DOH}). Set $V_1=1.8V$, $V_2=0V$ and $V_4=0.5V$. DO pin resistance is the DO pin L resistance (R_{DOL}).

(9) Measurement Condition 9, Measurement Circuit 5

<Overcharge detection delay time, Overdischarge detection delay time.>

The overcharge detection delay time (t_{CU}) is the time needed for V_{CO} to change from "H" to "L" just after the V1 rapid increase within 10 μ s from the overcharge detection voltage (V_{CU}) - 0.2V to the overcharge detection voltage (V_{CU}) + 0.2V in the condition V2=0V. The overdischarge detection delay time (t_{DL}) is the time needed for V_{DO} to change from "H" to "L" just after the V1 rapid decrease within 10 μ s from the overdischarge detection voltage (V_{DL})+0.2V to the overdischarge detection voltage (V_{DL}) - 0.2V in the condition V2=0V.

(10) Measurement Condition 10, Measurement Circuit 5

<Overcurrent 1 detection delay time, Overcurrent 2 detection delay time, Load short – circuiting detection delay time, Abnormal charge current detection delay time.>

Set V1=3.5V and V2=0V. Increase V2 from 0V to 0.35 V momentarily (within 10 μ s). The time needed for V_{DO} to go "L" is overcurrent 1 detection delay time (t_{IOV1}). Set V1=3.5V and V2=0V. Increase V2 from 0V to 0.7V momentarily (within 10 μ s). The time needed for V_{DO} to go "L" is overcurrent 2 detection delay time (t_{IOV2}).

Set V1=3.5V and V2=0V. Increase V2 from 0V to 1.6V momentarily (within 10 μ s). The time needed for V_{DO} to go "L" is the load short-circuiting detection delay time (t_{SHORT}).

Set V1=3.5V and V2=0V. Decrease V2 from 0V to 1.1V momentarily (within 10 μ s). The time needed for V_{CO} to go "L" is the abnormal charge current detection delay time. The abnormal charge current detection delay time has the same value as the overcharge detection delay time.

(11) Measurement Condition 11, Measurement Circuit 2 (Product with 0V battery charge function)

<0V battery charge starting charge voltage>

Set V1=V2=0V and decrease V2 gradually. The voltage between VDD and VM when V_{CO} goes "H" ($V_{VM}+0.1V$ or higher) is the 0V battery charge starting charger voltage (V_{0CHA}).

(12) Measurement Condition 12, Measurement Circuit 2 (Product with 0V battery charge inhibition function)

<0V battery charge inhibition battery voltage>

Set V1=0V and V2=4V. Increase V1 gradually. The voltage between VDD and VM when V_{CO} goes "H" ($V_{VM}+0.1V$ or higher) is the 0V battery charge inhibition battery voltage (V_{0INH}).

Measurement Circuit

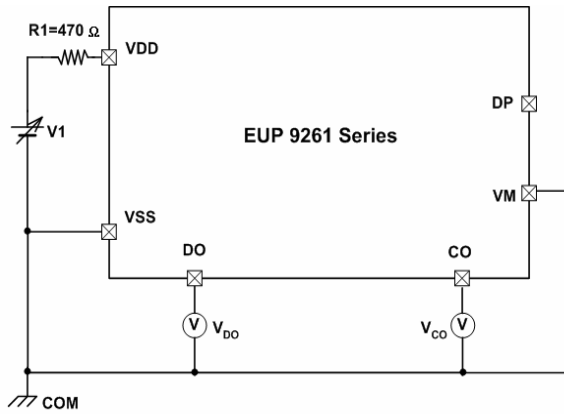

Measurement Circuit 1

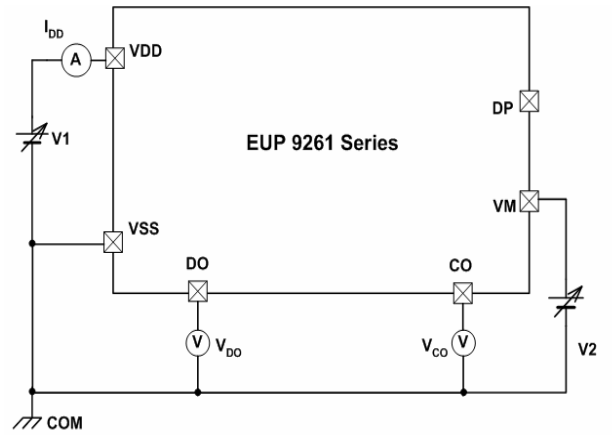

Measurement Circuit 2

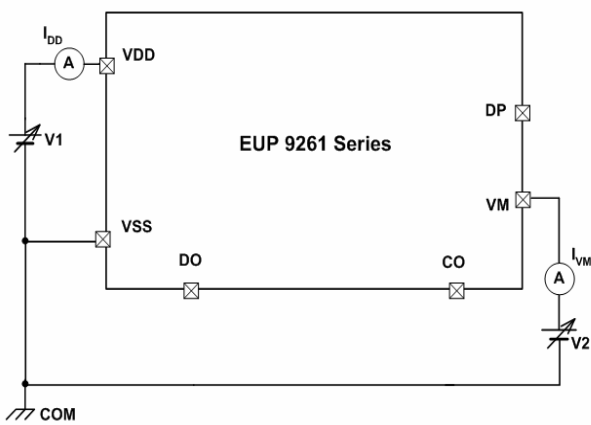

Measurement Circuit 3

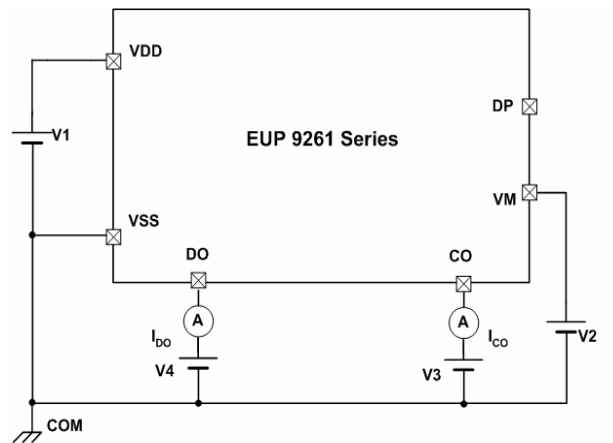

Measurement Circuit 4

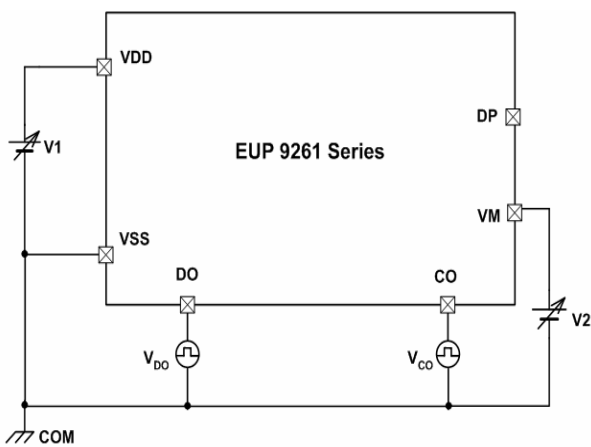

Measurement Circuit 5

Characteristics

1. Detection/release voltage temperature characteristics

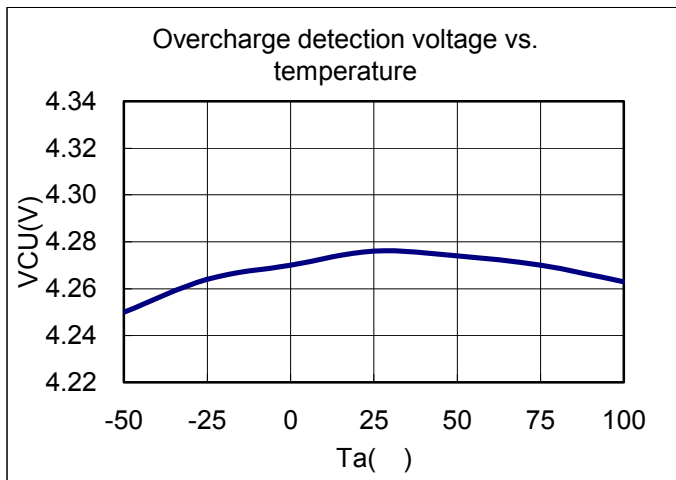

Figure3.

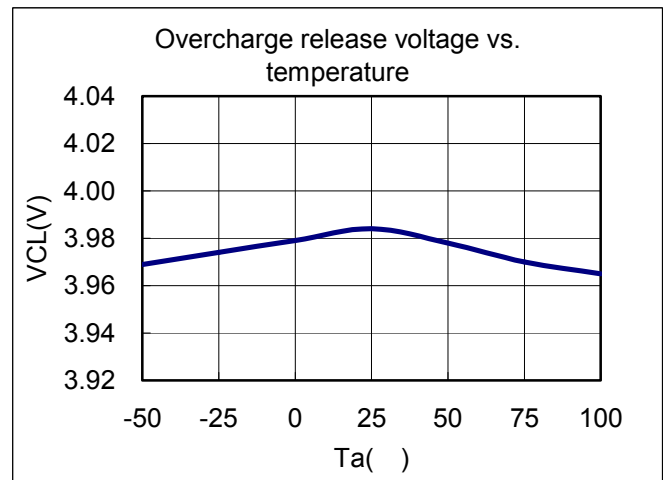

Figure4.

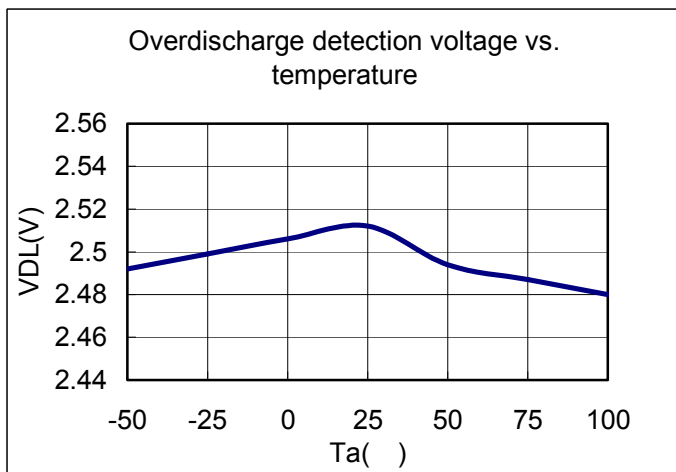

Figure5.

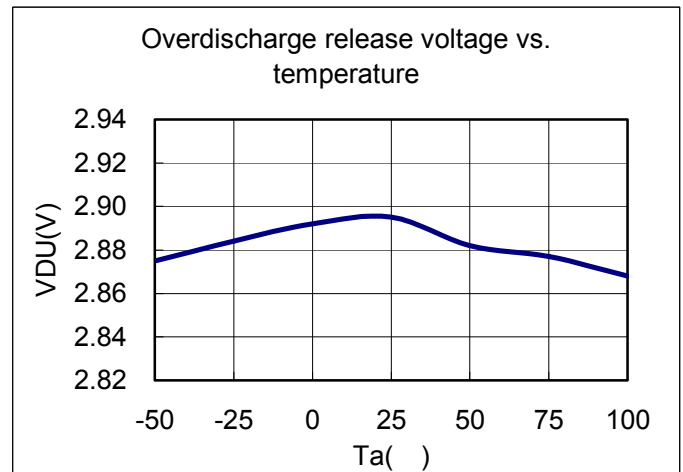

Figure6.

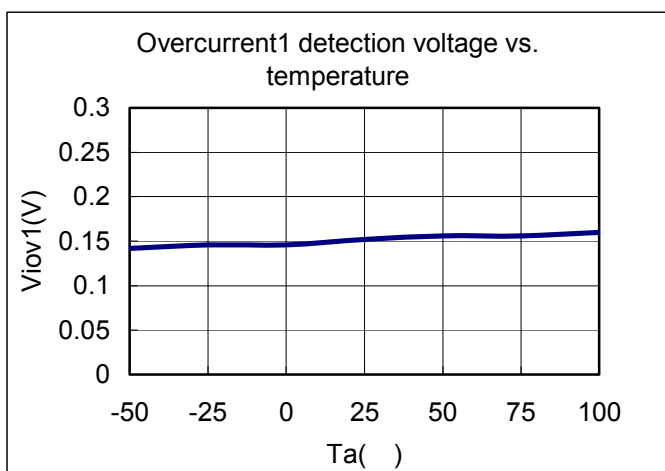

Figure7.

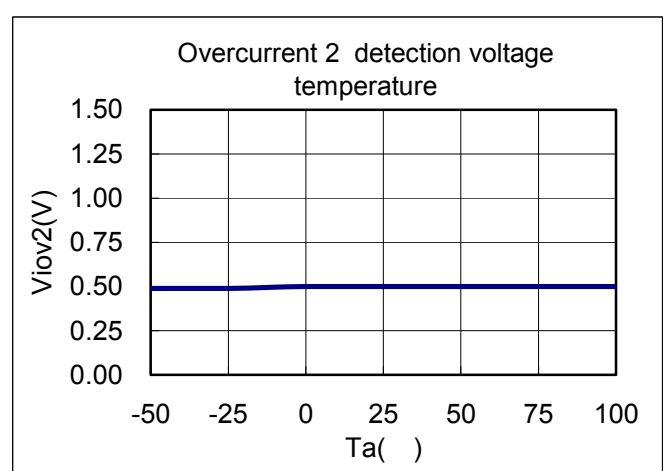

Figure8.

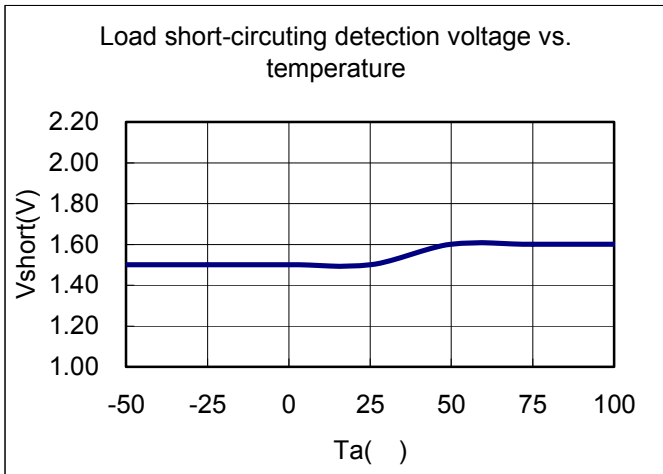

Figure9.

2. Current consumption temperature characteristics

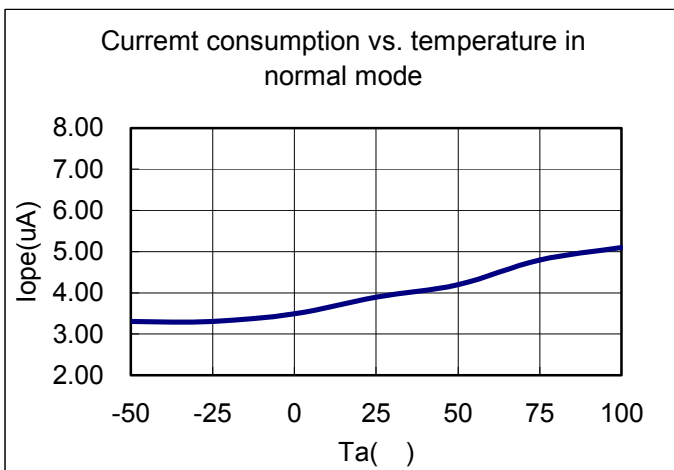

Figure10.

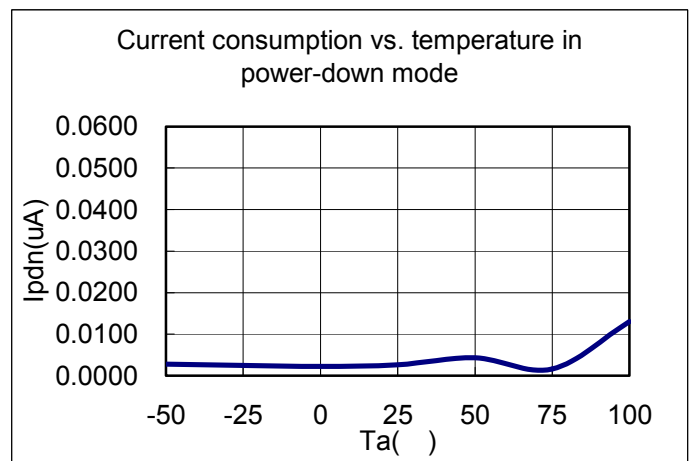

Figure11.

3. Detection/release delay time temperature characteristics

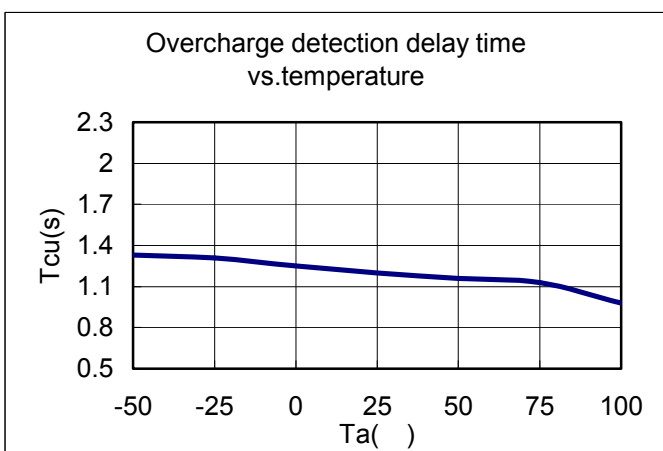

Figure12.

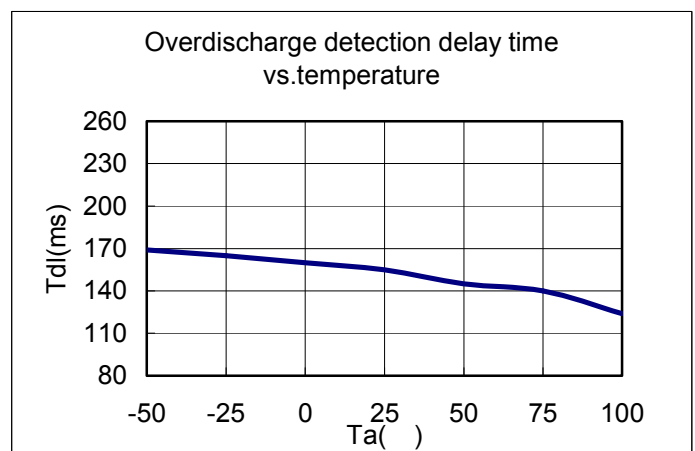

Figure13.

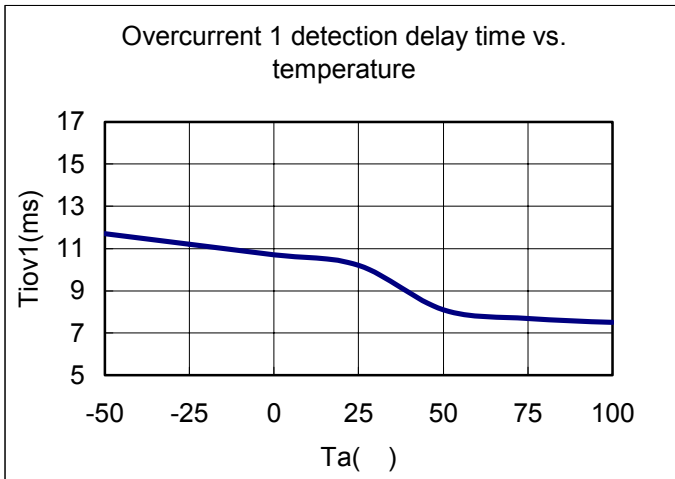

Figure14.

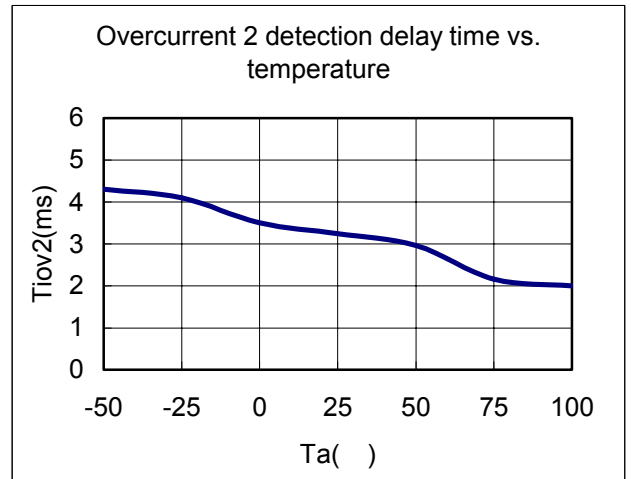

Figure15.

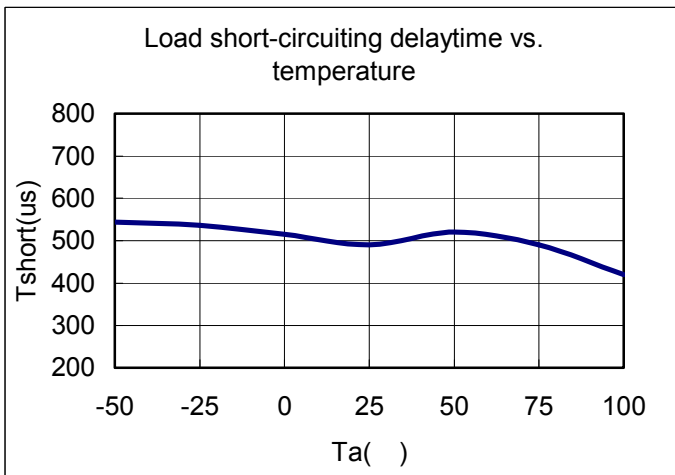

Figure16.

Description of Operation

Normal condition

The EUP9261 monitors the voltage of the battery connected between VDD and VSS pin and the voltage difference between VM and VSS pin to control charging and discharging. When the battery voltage is in the range from the overdischarge detection voltage (V_{DL}) to the overcharge detection voltage (V_{CU}), and the VM pin voltage is in the range from the charger detection voltage (V_{CHA}) to the overcurrent 1 detection voltage (V_{IOV1}), the IC turns both the charging and discharging control FETs on. This condition is called the normal condition, and in this condition charging and discharging can be carried out freely.

Note: When a battery is connected to the IC for the first time, the battery may not enter dischargeable state. In this case, set the VM pin voltage equal to the VSS voltage or connect a charger to enter the normal condition.

Overcurrent condition (Detection of Overcurrent 1, Overcurrent 2 and Load short-circuiting)

When the condition in which VM pin voltage is equal to or higher than the overcurrent detection voltage, condition that caused by the excess of discharging current over a specified value, continues longer than the overcharge detection delay time in a battery under the normal condition, the EUP9261 turns the discharging control FET off to stop discharging. This condition is called the overcurrent condition. Though the VM and VSS pins are shorted by the R_{VMS} resistor in the IC under the overcurrent condition, the VM pin voltage is pulled to the VDD level by the load as long as the load is connected. The VM pin voltage returns to VSS level when the load is released. The overcurrent condition returns to the normal condition when the impedance between the EB+ and EB- pin (see Figure 2) becomes higher than the automatic recoverable impedance, and the IC detects that the VM pin potential is lower than the overcurrent 1 detection voltage (V_{IOV1}).

Note: The automatic recoverable impedance changes depending on the battery voltage and overcurrent 1 detection voltage settings.

Overcharge condition

When the battery voltage becomes higher than the overcharge detection voltage (V_{CU}) during charging under the normal condition and the detection continues for the overcharge detection delay time (t_{CU}) or longer, the EUP9261 turns the charging control FET off to stop charging. This condition is called the overcharge condition. The overcharge condition is released by the following two cases ((1) and (2)):

(1) When the battery voltage falls below the overcharge release voltage, which is equal to the overcharge detection voltage (V_{CU}) overcharge detection hysteresis voltage (V_{HC}), the EUP9261 turns the charging control FET on and turns to the normal condition.

(2) When a load is connected and discharging starts, the EUP9261 turns the charging control FET on and returns to the normal condition. Just after the load is connected and discharging starts, the discharging current flows through the parasitic diode in the charging control FET. At this moment the VM pin potential becomes V_f -volt, the voltage for the parasitic diode, higher than VSS level. When the battery voltage goes under the overcharge detection voltage (V_{CU}) and provided that the VM pin voltage is higher than the overcurrent 1 detection voltage, the EUP9261 releases the overcharge condition.

Note1:

If the battery is charged to a voltage higher than the overcharge detection voltage (V_{CU}) and the battery voltage does not fall below the overcharge detection voltage (V_{CU}) even when a heavy load is connected, the detection of overcurrent 1, overcurrent 2 and load short-circuiting does not work. Since an actual battery has the internal impedance of several dozens of $m\Omega$, the battery voltage drops immediately after a heavy load which causes overcurrent is connected, and the detection of overcurrent 1, overcurrent 2 and load short-circuiting then works.

Note2:

When a charger is connected after the overcharge detection, the overcharge condition is not released even if the battery voltage is below the overcharge release voltage ($V_{CL} (= V_{CU} - V_{HC})$). The overcharge condition is released when the VM pin voltage goes over the charger detection voltage (V_{CHA}) by removing the charger.

Overdischarge condition

When the battery voltage falls below the overdischarge detection voltage (V_{DL}) during discharging under the normal condition and the detection continues for the overdischarge detection delay time (t_{DL}) or longer, the EUP9261 turns the discharging control FET off to stop discharging. This condition is called the overdischarge condition. When the discharging control FET turns off, the VM pin voltage is pulled up by the R_{VMD} resistor between VM and VDD in the IC. The voltage difference between VM and VDD then falls below 1.3V (typ.), the current consumption is reduced to the power-down current consumption (I_{PDN}). This condition is called the power-down condition. The power-down condition is released when a charger is connected and the voltage difference between VM and VDD becomes 1.3V (typ.) or higher. Moreover when the battery voltage becomes the overdischarge detection voltage (V_{DL}) or higher, the EUP9261 turns the discharging control FET on and returns to the normal condition.

Charger detection

When a battery in the overdischarge condition is connected to a charger and provided that the VM pin voltage is lower than the charger detection voltage (V_{CHA}), the EUP9261 releases the overdischarge condition and turns the discharging control FET on as the battery voltage becomes equal to or higher than the overdischarge detection voltage (V_{DL}) since the charger detection function works. This action is called charger detection. When a battery in the overdischarge condition is connected to a charger and provided that the VM pin voltage is not lower than the charger detection voltage (V_{CHA}), the EUP9261 releases the Overdischarge condition when the battery voltage reaches the overdischarge detection voltage (V_{DL}) overdischarge hysteresis (V_{HD}) or higher.

Abnormal charge current detection

If the VM pin voltage falls below the charger detection voltage (V_{CHA}) during charging under normal condition and it continues for the overcharge detection delay time (t_{CU}) or longer, the charging control FET turns off and charging stops. This action is called the abnormal charge current detection. Abnormal charge current detection works when the DO pin voltage is "H" and the VM pin voltage falls below the charger detection voltage (V_{CHA}). Consequently, if an abnormal charge current flows to an over-discharged battery, the EUP9261 turns the charging control FET off and stops charging after the battery voltage becomes higher than the overdischarge detection voltage which make the DO pin voltage "H", and still after the overcharge detection delay time (t_{CU}) elapses.

Abnormal charge current detection is released when the voltage difference between VM pin and VSS pin becomes less than charger detection voltage (V_{CHA}).

Delay circuits

The detection delay times are generated by dividing the approximate 3.5 KHZ clock with a counter.

Note1:

The detection delay time for overcurrent 2 and load short-circuiting start when the overcurrent 1 is detected. As soon as the overcurrent 2 or load short-circuiting is detected over the detection delay time for overcurrent 2 or load short-circuiting after the detection of Overcurrent 1, the EUP9261 turns the discharging control FET off.

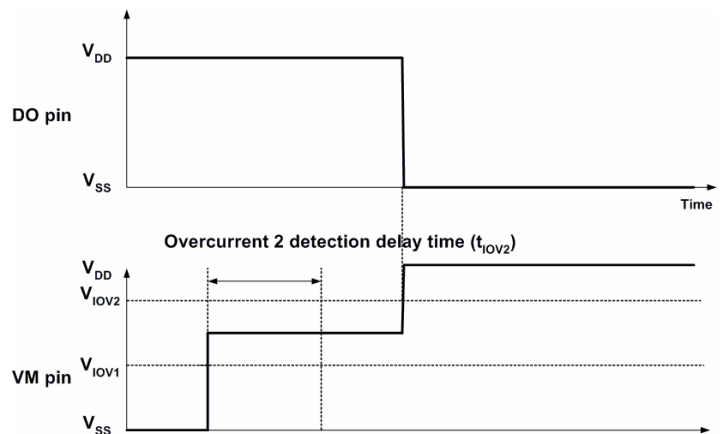

Figure17.

Note2:

When the overcurrent is detected and it continues for longer than the Overdischarge detection delay time without releasing the load, the load, the condition changes to the power-down condition when the battery voltage falls below the Overdischarge detection voltage.

Note3:

When the battery voltage falls below the Overdischarge detection voltage due to the overcurrent, the EUP9261 turns the discharging control FET off by the overcurrent detection. And in this case the recovery of the battery voltage is so slow that the battery voltage after the Overdischarge detection delay time is still lower than the Overdischarge detection voltage, the EUP9261 transits to the power-down condition.

DP pin

The DP pin is a test pin for delay time measurement and for output delay time reduction or bypass. It should be open or VDD level in the actual application.

For reducing delay time, connect this pin with a 300kΩ resistor to VSS. An internal clock can be measured. Under this condition, output delay time of over-charge, over-discharge, over-current1 and over-current2 can be shorter than the setting value (delay time for over charge becomes about 1/64 of normal state).

By forcing this pin to VSS, output delay time circuit can be disabled.

0V battery charge function^{*1*2}

This function is used to recharge the connected battery whose voltage is 0V due to the self-discharge.

When the 0V battery charge starting charge voltage (VOCHA) or higher is applied between EB+ pin and EB-pin by connecting a charger, the charging control FET gate is fixed to VDD pin voltage. When the voltage between the gate and source of the charging control FET becomes equal to or higher than the turn-on voltage e by the charger voltage, the charging control FET turns on to start charging. At this time, the discharging control FET is off and the charging current flows through the internal parasitic diode in the discharging control FET. When the battery voltage becomes equal to or higher than the overdischarge release voltage (VDU), the EUP9261 enters the normal condition.

0V battery charge inhibition function^{*1}

This function inhibits the recharging when a battery which is short-circuited (0V) internally is connected. When the battery voltage is 0.6V (typ.) or lower, the charging control FET gate is fixed to EB- pin voltage to inhibit charging. When the battery voltage is the 0V battery charge inhibition battery voltage (VOINH) or higher, charging can be performed.

- *1. Some battery providers do not recommend charging for completely self-discharged battery. Please ask battery providers before determining the 0V battery charge function.
- *2. The 0V battery charge function has higher priority than the abnormal charge current detection function. Consequently, a product with the 0V battery charge function charges a battery forcedly and abnormal charge current cannot be detected when the battery voltage is low.

Operation Timing Chart

1. Overcharge and Overdischarge Detection

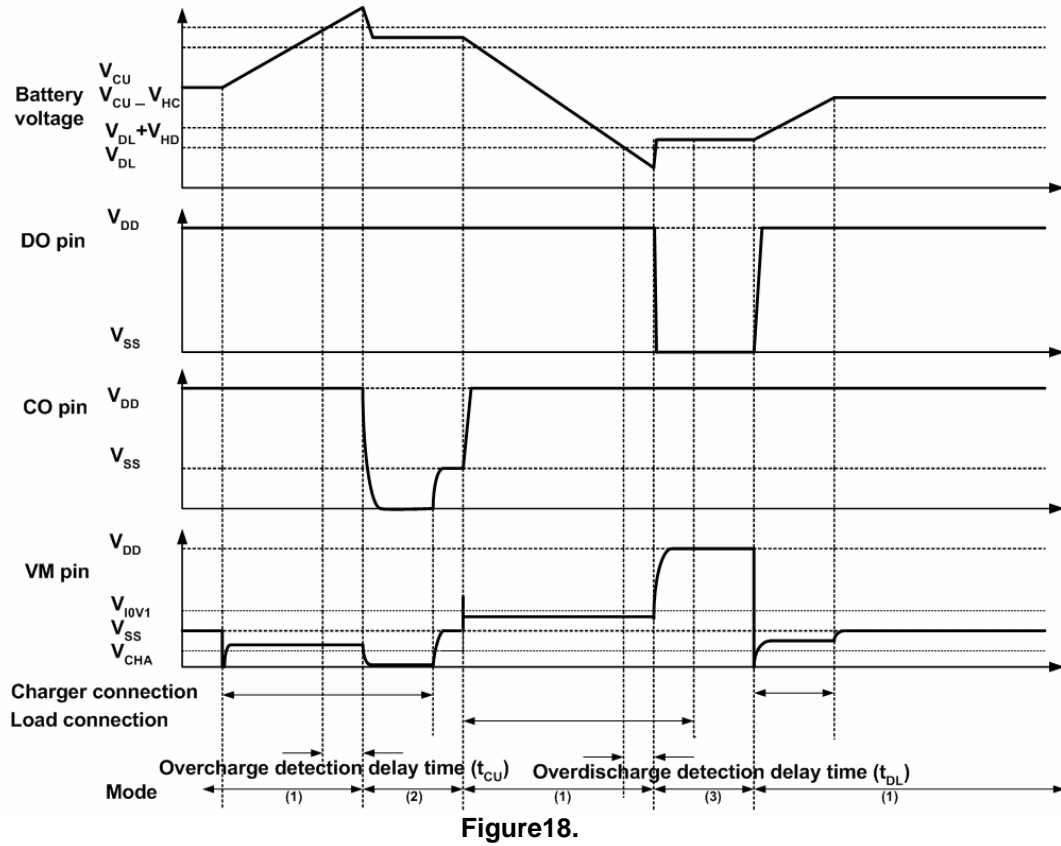

Figure18.

2. Overcurrent Detection

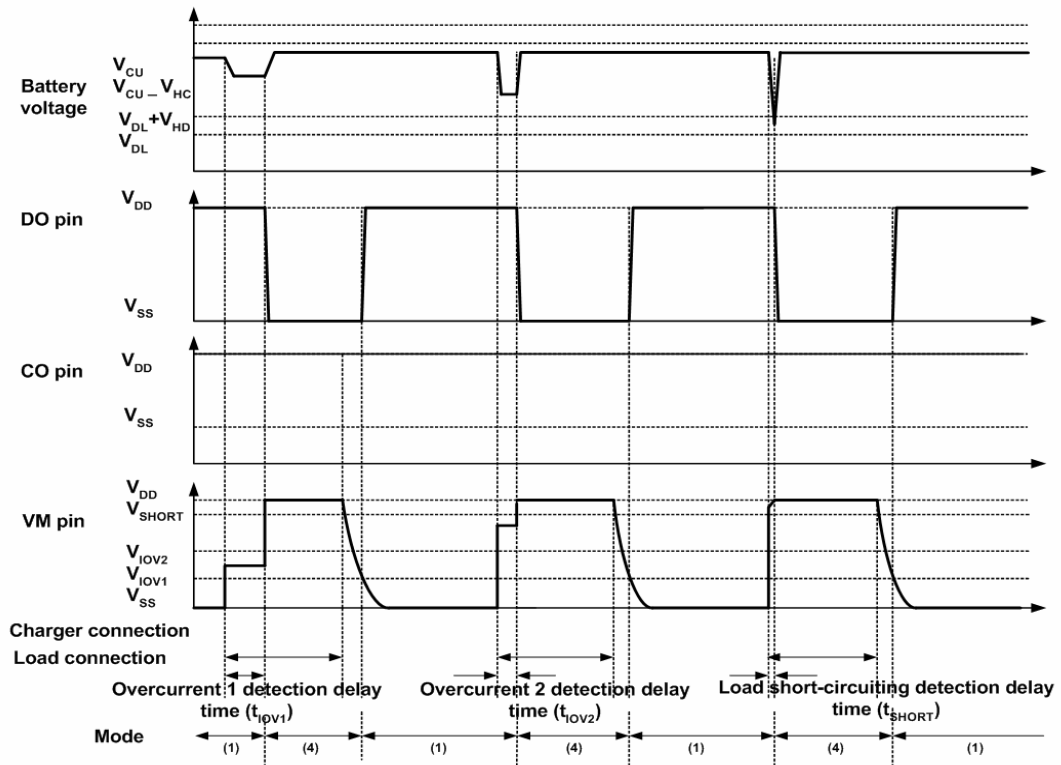

Figure19.

Note: (1) Normal condition. (2) Overcharge condition. (3) Overdischarge condition. (4) Overcurrent condition
The charger is supposed to charge with constant current

3. Charger Detection

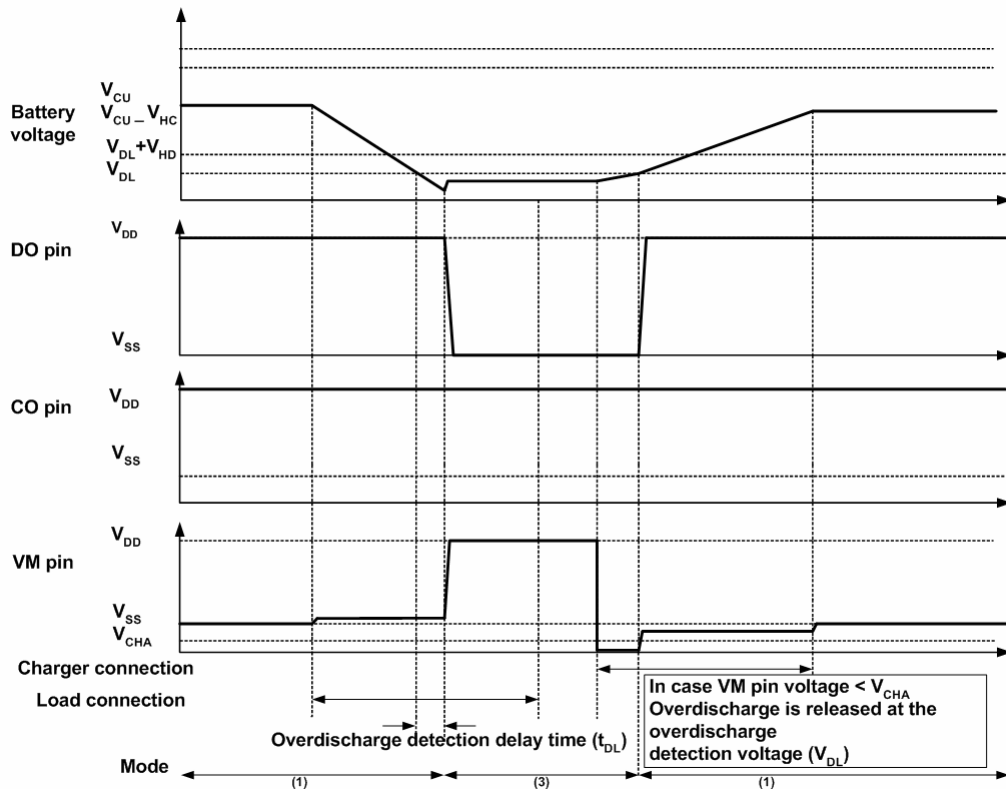

Figure20.

4. Abnormal Charge Current Detection

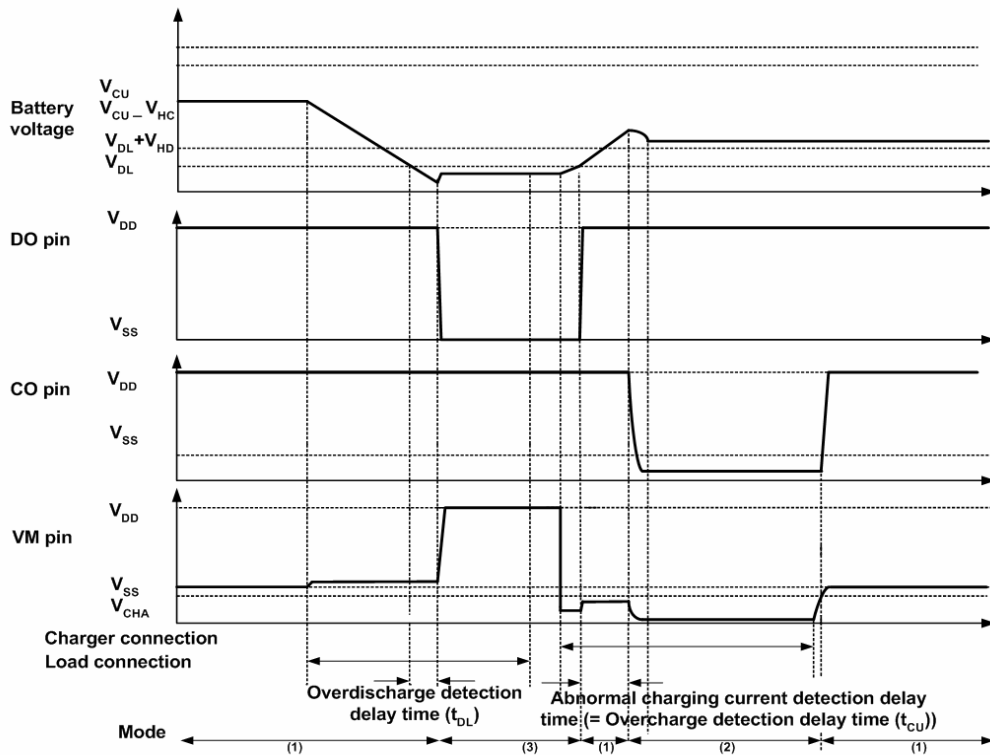
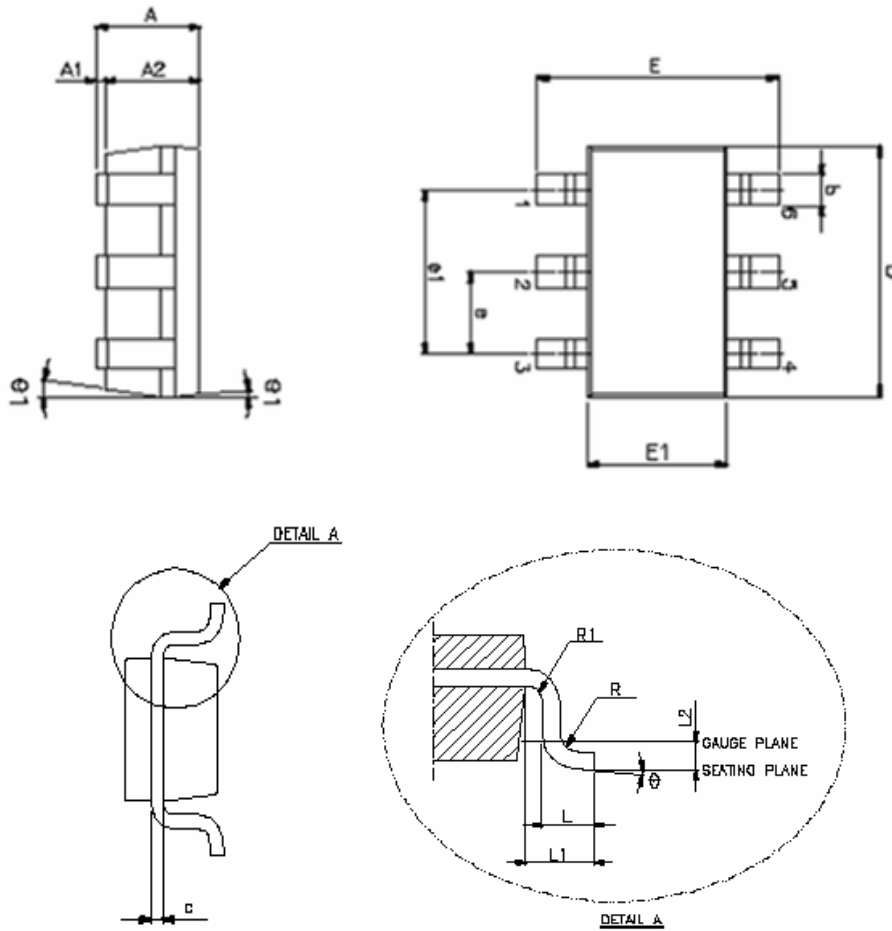

Figure21.

Note: (1) Normal condition. (2) Overcharge condition. (3) Overdischarge condition. (4) Overcurrent condition
The charger is supposed to charge with constant current

Package Information



SYMBOLS	DIMENSIONS IN MILLIMETERS		
	MIN.	NOM.	MAX.
A	-----	-----	1.45
A1	-----	-----	0.15
A2	0.90	1.15	1.30
b	0.30	-----	0.50
C	0.08	-----	0.22
D	2.90 BSC		
E	2.80 BSC		
E1	1.60 BSC		
e	0.95 BSC		
E1	1.90 BSC		
L	0.30	0.45	0.60
L1	0.60 REF		
L2	0.25 BSC		
R	0.10	-----	-----
R1	0.10	-----	0.25
	0°	4°	8°
1	5°	10°	15°