

# Ferrite for Switching Power Supplies

## INTRODUCTION

Our foremost mission is to develop unique and advanced electronics technologies. As such, ever since TDK was founded in 1935 when its researchers invented ferrite, we have been involved in a wide range of technological and product development efforts. Particularly, our high-performance ferrite elements, which result from our accumulated expertise and excellent microstructure control technologies, have become essential in reducing the weight and improving the performance of advanced electronic devices that are transforming the world around us.

As a result of pursuing the numerous potentials of these ferrite elements, we have been able to develop high-frequency power ferrite material that deliver among the world's highest levels of reliability and magnetic properties. These products include PC33, PC40, PC44, PC45, PC46, PC47, and PC50. They contribute to achieving even greater size reductions and performance improvements of high-performance switching power supplies and DC to DC converters -- products considered to constitute the heart of microelectronic devices. We have also developed the PC95, which delivers a saturated magnetic flux density equivalent to that of PC44 and low loss in a wide temperature range. This materials is expected to improve the efficiency of power supplies in DC to DC converters used in electric vehicles.

Additionally, we have been conducting research in ferrite that delivers permeability close to the theoretical limit in high frequency ranges. These ferrite materials are designed for EMC solutions. The materials HS52, HS72, and HS10 deliver frequency responses with excellent permeability - a prerequisite for EMC magnetic material such as EMI filters and common mode choke coils - and higher impedance compared to existing material in the high frequency ranges.

In parallel with material development, we have been working to reduce sizes and improve the performance of our switching power supplies and DC to DC converters. To this end, we have been developing optimum core shape designs and creating an extensive line up of these products to accommodate a wide range of specific needs. We also manufacture peripheral items including bobbins and various accessories.

# CIRCUIT EXAMPLE

## SINGLE FORWARD CONVERTER

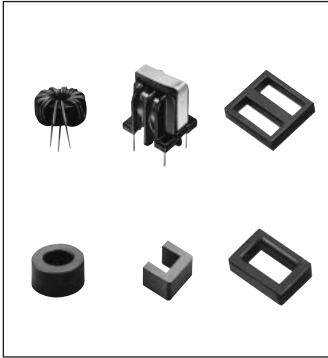

Common mode choke coil

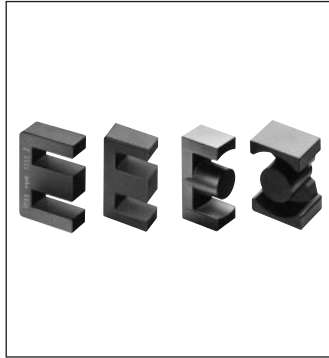

Active filter choke coil

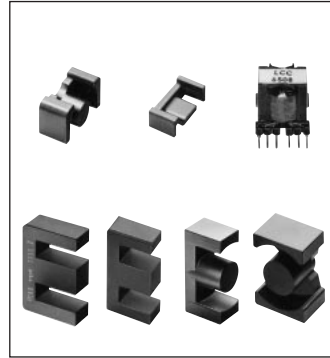

Main power transformer

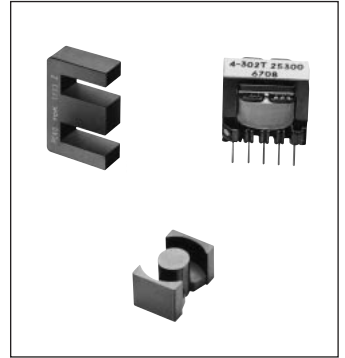

Smoothing choke coil

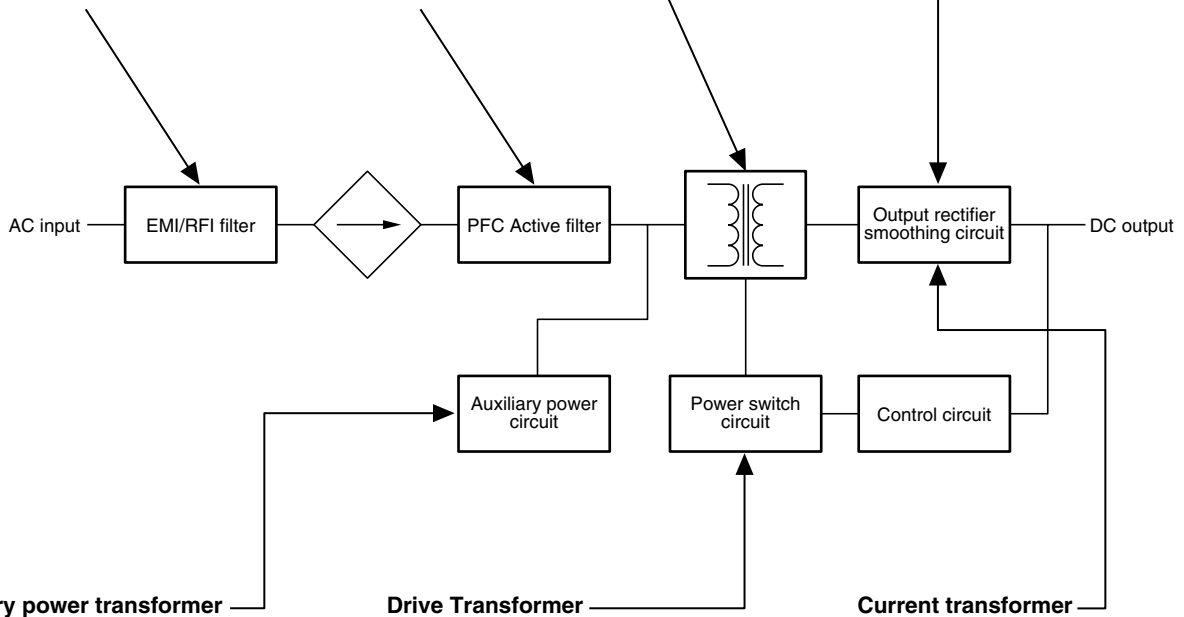

Auxiliary power transformer

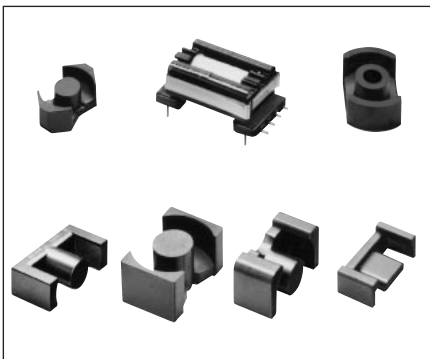

Drive Transformer

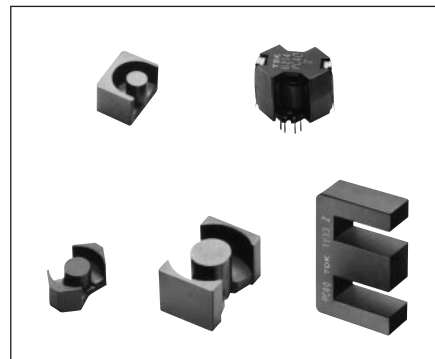

Current transformer

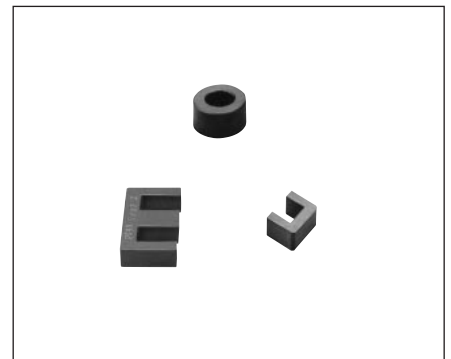

- Notes:
- LP and EPC cores are ideal for use in thin transformers.
  - LP cores are available in .5 and .7 inches in height (when mounted).
  - EP cores are available in .5 and .65 inches in height (when mounted).

## SELECTED ITEMS OF LEGEND

$C_1 = \sum \frac{\ell}{A}$	Core constant mm <sup>-1</sup>
<b>Ae</b>	Effective cross-sectional area, mm <sup>2</sup>
$\ell_e$	Effective magnetic path length, mm
<b>Ve</b>	Effective core volume mm <sup>3</sup>
<b>Acp</b>	Cross-sectional center leg/pole area, mm <sup>2</sup>
<b>Acp min.</b>	Minimum cross-sectional center pole area, mm <sup>2</sup>
<b>Acw</b>	Cross-sectional winding area of core, mm <sup>2</sup>
<b>Aw</b>	Cross-sectional winding area of bobbin, mm <sup>2</sup>
$\ell_w$	Average length of turns around bobbin, mm
<b>t</b>	Minimum thickness of bobbin inside which core is placed, including flanges, mm
<b>W</b>	Bobbin-core assembly dimensions
<b>D</b>	Bobbin-core assembly dimensions
<b>H</b>	Bobbin-core assembly dimensions

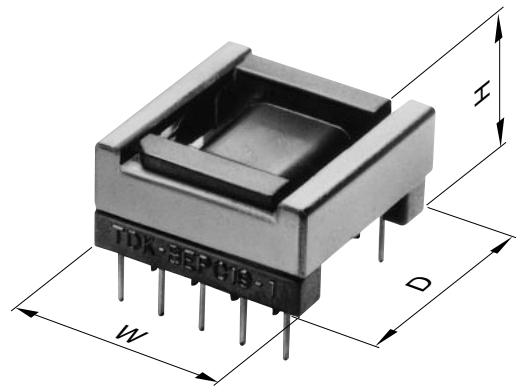
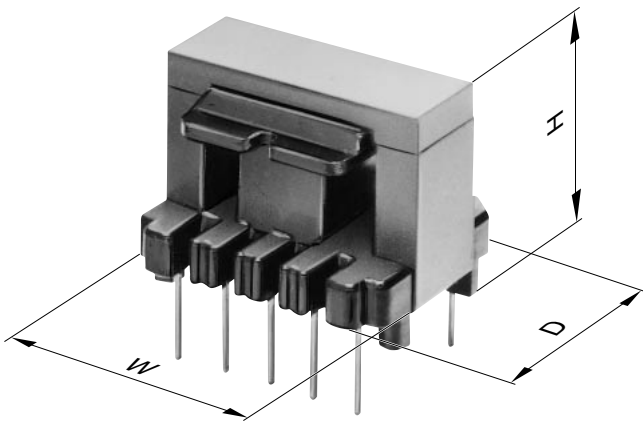

# MATERIAL CHARACTERISTICS

## MATERIAL CHARACTERISTICS

### For Transformer and Choke

Material				PC40	PC44	PC47	PC50	
Initial permeability	$\mu_i$			2300±25%	2400±25%	2500±25%	1400±25%	
Amplitude permeability	$\mu_a$			3000 min.	3000 min.			
Core loss volume density (Core loss)* [B=200mT]	P <sub>cv</sub>	kW/m <sup>3</sup>	25kHz sine wave	25°C				
				60°C	120			
				100°C	80			
				120°C	70			
			100kHz sine wave	25°C	600	600	600	130**
				60°C	450	400	400	80**
				100°C	410	300	250	80**
				120°C	500	380	360	110**
Saturation magnetic flux density* [H=1194A/m]	B <sub>s</sub>	mT	25°C	510	510	530	470	
			60°C	450	450	480	440	
			100°C	390	390	420	380	
			120°C	350	350	390	350	
Remanent flux density*	B <sub>r</sub>	mT	25°C	95	110	180	140	
			60°C	65	70	100	110	
			100°C	55	60	60	98	
			120°C	50	55	60	100	
Coercive force*	H <sub>c</sub>	A/m	25°C	14.3	13	13	36.5	
			60°C	10.3	9	9	31.0	
			100°C	8.8	6.5	6	27.2	
			120°C	8	6	7	26.0	
Curie temperature	T <sub>c</sub>	°C		>215	>215	>230	>240	
Density*	d <sub>b</sub>	kg/m <sup>3</sup>		4.8×10 <sup>3</sup>	4.8×10 <sup>3</sup>	4.9×10 <sup>3</sup>	4.8×10 <sup>3</sup>	
Electrical resistivity*	$\rho_v$	$\Omega \cdot m$		6.5	6.5	4.0	30	

Material				PC45	PC46	PC33	PC95	
Initial permeability	$\mu_i$			2500±25%	3200±25%	1400±25%	3300±25%	
Amplitude permeability	$\mu_a$							
Core loss volume density (Core loss)* [B=200mT]	P <sub>cv</sub>	kW/m <sup>3</sup>	100kHz sine wave	25°C	570	350	1100	350
				60°C	250(75°C)	250(45°C)	800	
				100°C	460	660	600	290
				120°C	650	760	680	350
Saturation magnetic flux density* [H=1194A/m]	B <sub>s</sub>	mT	25°C	530	520	510	530	
			60°C	480	470	490	480	
			100°C	420	410	440	410	
			120°C	390	380	420	380	
Remanent flux density*	B <sub>r</sub>	mT	25°C	120	80	220	85	
			60°C	80	80	150	70	
			100°C	80	130	100	60	
			120°C	110	140	100	55	
Coercive force*	H <sub>c</sub>	A/m	25°C	12	10	23	9.5	
			60°C	9	9	17	7.5	
			100°C	8	10	14	6.5	
			120°C	9	9	14	6.0	
Curie temperature	T <sub>c</sub>	°C		>230	>230	>290	>215	
Density*	d <sub>b</sub>	kg/m <sup>3</sup>		4.8×10 <sup>3</sup>	4.8×10 <sup>3</sup>	4.8×10 <sup>3</sup>	4.9×10 <sup>3</sup>	
Electrical resistivity*	$\rho_v$	$\Omega \cdot m$		3.0	3.0	2.5	6.0	

\* Average value

\*\* 500kHz, 50mT

### For Common Mode Choke

Material				HS52	HS72	HS10
Initial permeability	$\mu$			5500±25%	7500±25% (2000min. at 500kHz)	10000±25%
Relative loss factor*	$\tan\delta/\mu$	$\times 10^{-6}$		10(100kHz)	30(100kHz)	30(100kHz)
Saturation magnetic flux density* [H=1194A/m]	Bs	mT	25°C	410	410	380
Remanent flux density*	Br	mT	25°C	70	80	120
Coercive force*	Hc	A/m	25°C	6	6	5
Curie temperature	Tc	°C		>130	>130	>120
Density*	db	kg/m <sup>3</sup>		4.9×10 <sup>3</sup>	4.9×10 <sup>3</sup>	4.9×10 <sup>3</sup>
Electrical resistivity*	$\rho v$	$\Omega \cdot m$		1	0.2	0.2

### For Telecommunication

Material				H5A	H5B2	H5C2	H5C3	H5C4
Initial permeability	$\mu$			3300 <sup>+40%</sup> <sub>-0%</sub>	7500±25%	10000±30%	15000±30%	12000±30% ≥ 9000(-20°C)
Relative loss factor	$\tan\delta/\mu$	$\times 10^{-6}$		<2.5(10kHz) <10(100kHz)	<6.5(10kHz)	<7.0(10kHz)	<7.0(10kHz)	<8(10kHz)
Temperature factor of initial permeability	$\alpha\mu$	$\times 10^{-6}$	-30 to +20°C 0 to 20°C 20 to 70°C	-0.5 to 2.0 -0.5 to 2.0	0 to 1.8 0 to 1.8	-0.5 to 1.5 -0.5 to 1.5	-0.5 to 1.5 -0.5 to 1.5	
Saturation magnetic flux density* [H=1194A/m]	Bs	mT	25°C	410	420	400	360	380
Remanent flux density*	Br	mT	25°C	100	40	90	105	100
Coercive force*	Hc	A/m	25°C	8.0	5.6	7.2	4.4	4.4
Curie temperature	Tc	°C		>130	>130	>120	>105	>110
Hysteresis material constant	$\eta_B$	$\frac{10^{-6}}{mT}$		<0.8	<1.0	<1.4	<0.5	<2.8
Disaccommodation factor	D <sub>F</sub>	$\times 10^{-6}$		<3	<3	<2	<2	<3
Density*	db	kg/m <sup>3</sup>		4.8×10 <sup>3</sup>	4.9×10 <sup>3</sup>	4.9×10 <sup>3</sup>	4.95×10 <sup>3</sup>	4.95×10 <sup>3</sup>
Electrical resistivity*	$\rho v$	$\Omega \cdot m$		1	0.1	0.15	0.15	0.15

Material				H5C5	HP5	DNW45	DN40	DN70
Initial permeability	$\mu$			30000±30%	5000±20%	4200±25%	4000±25%	7500±25%
Relative loss factor	$\tan\delta/\mu$	$\times 10^{-6}$	25°C, 10kHz	<15	<3.5	<3.5	<2.5	<2.0
Temperature factor of initial permeability	$\alpha\mu$	$\times 10^{-6}$	-30 to +20°C 0 to 20°C 20 to 70°C	-0.5 ~ 1.5 -0.5 ~ 1.5	±12.5% ±12.5%		-0.5 to 2.0 -0.5 to 2.0	-0.5 to 1.5 -0.5 to 1.5
Saturation magnetic flux density* [H=1194A/m]	Bs	mT	25°C	380	400	450	405	390
Remanent flux density*	Br	mT	25°C	120	65	50	95	45
Coercive force*	Hc	A/m	25°C	4.2	7.2	6.5	8.0	3.5
Curie temperature	Tc	°C		>110	>140	>150	>130	>105
Hysteresis material constant	$\eta_B$	$\frac{10^{-6}}{mT}$		<1.5	<0.4	<0.8	<0.8	<0.2
Disaccommodation factor	D <sub>F</sub>	$\times 10^{-6}$		<2	<3	<3	<3	<2.5
Density*	db	kg/m <sup>3</sup>		4.95×10 <sup>3</sup>	4.8×10 <sup>3</sup>	4.85×10 <sup>3</sup>	4.8×10 <sup>3</sup>	5.0×10 <sup>3</sup>
Electrical resistivity*	$\rho v$	$\Omega \cdot m$		0.15	0.15	0.65	1.0	0.3

\* Average value

**$\mu_i$  vs. Frequency Characteristics**

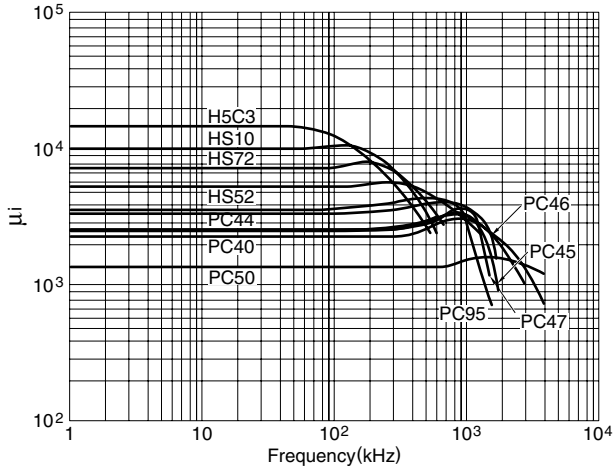

**$\tan \delta/\mu_i$  vs. Frequency Characteristics**

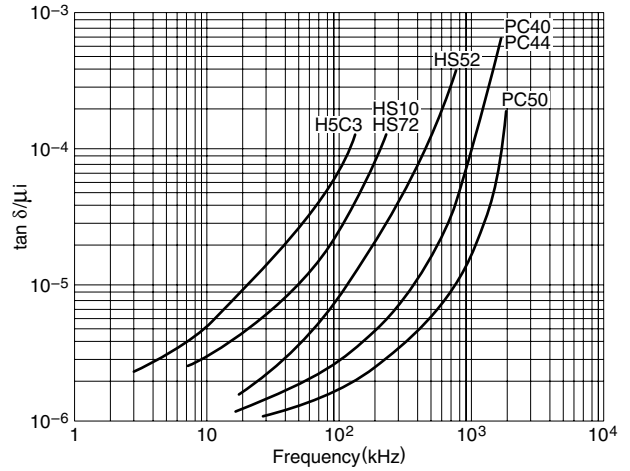

**Magnetization Curves (Typical)**

**Material: PC40**

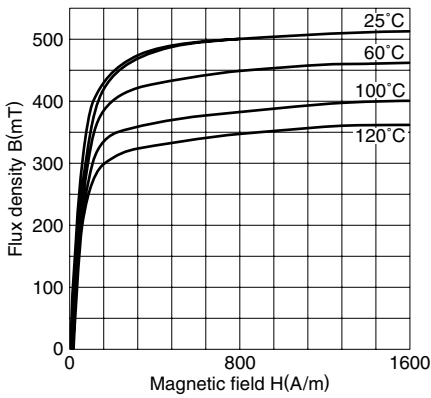

**Material: PC44**

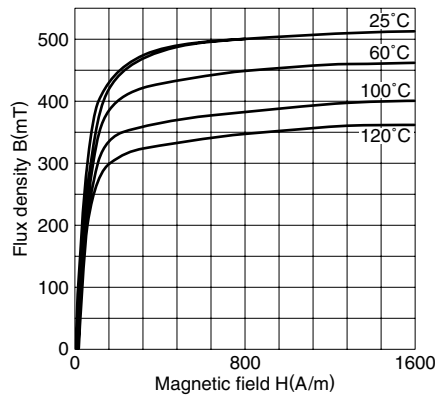

**Material: PC50**

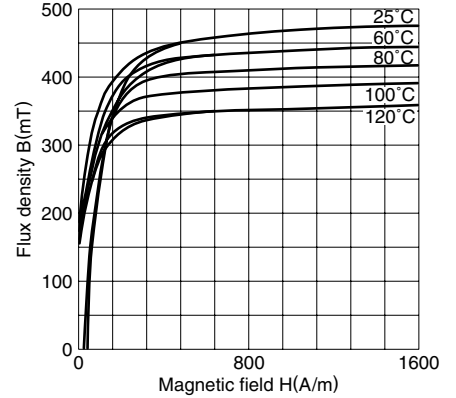

**Material: PC45**

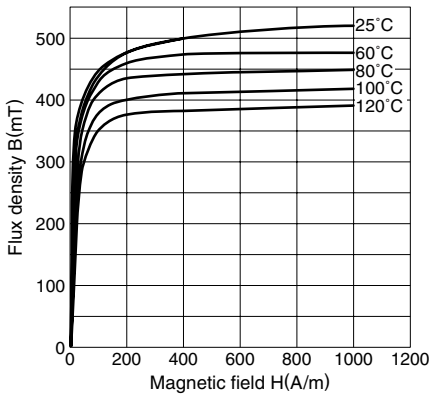

**Material: PC46**

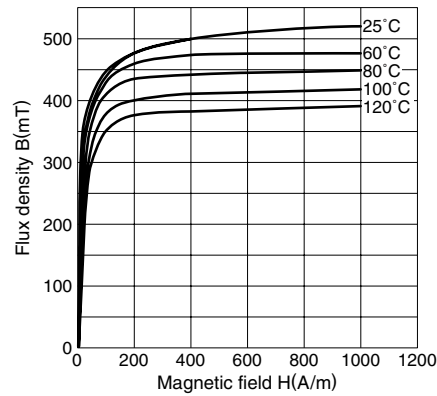

**Material: PC47**

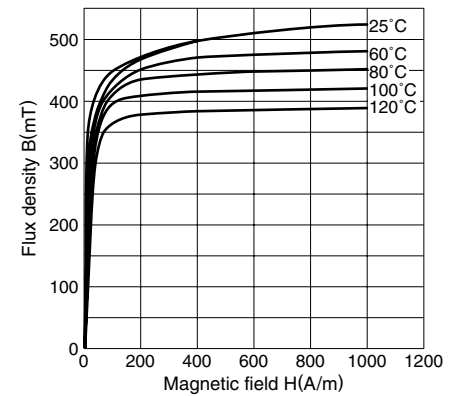

**Material: PC95**

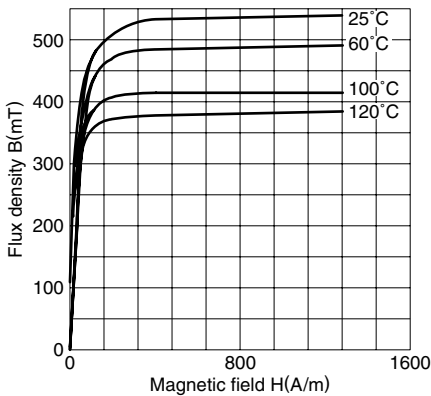

• All specifications are subject to change without notice.

### Core Loss (Typical)

Material: PC40

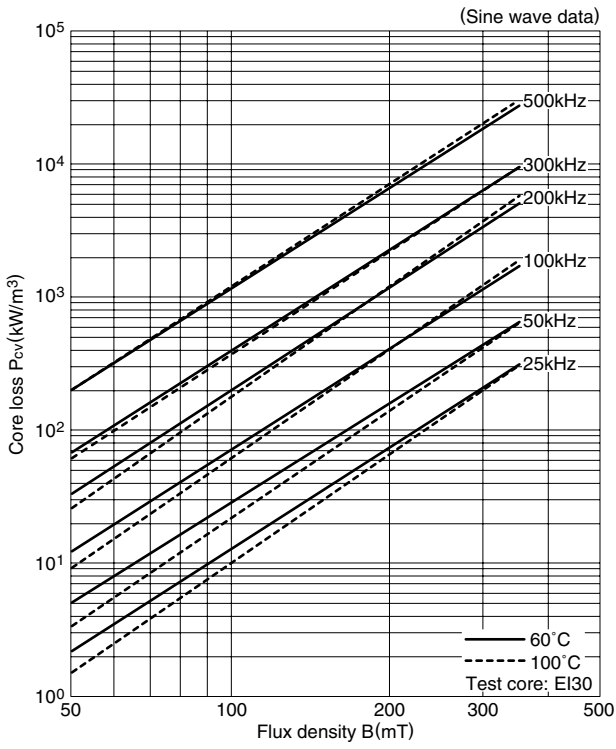

Material: PC44

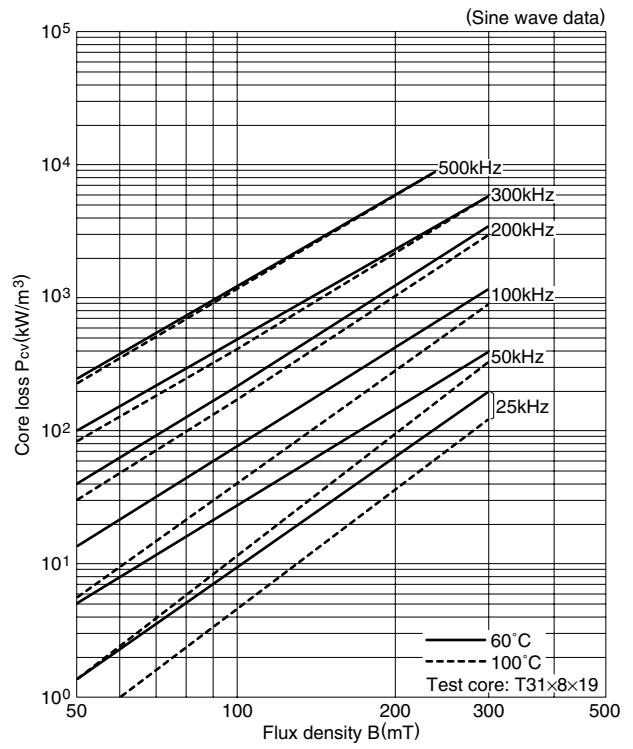

Material: PC50

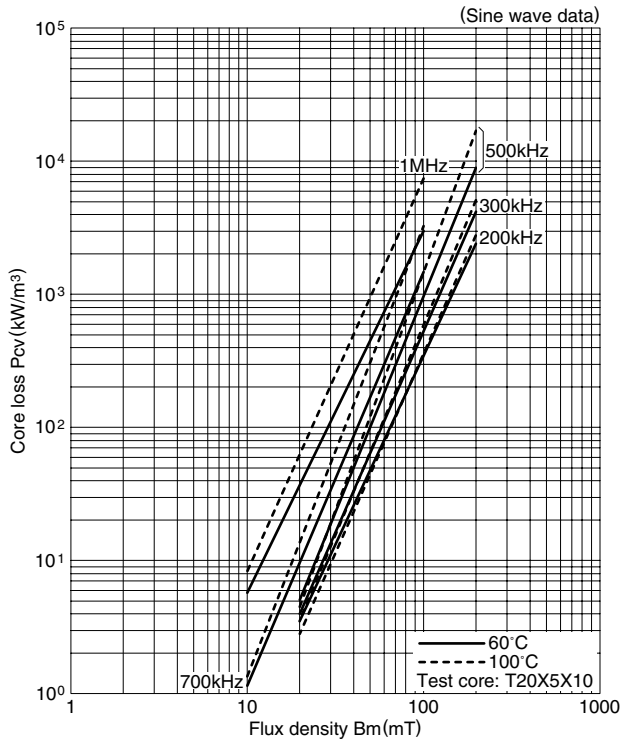

Material: PC45

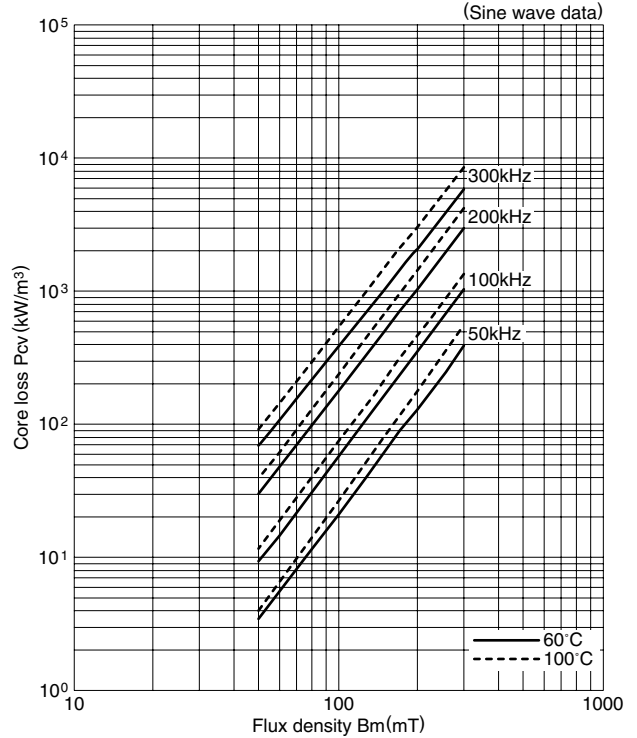

• All specifications are subject to change without notice.

### Core Loss (Typical)

Material: PC46

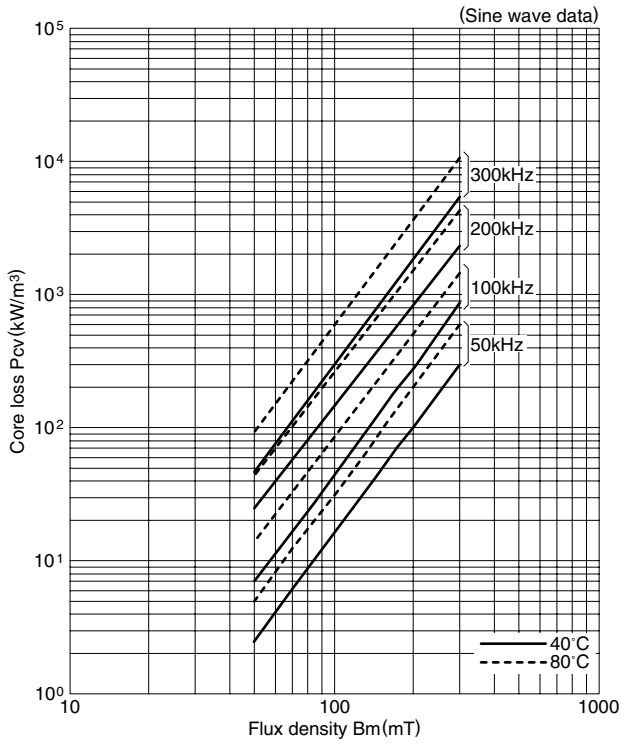

Material: PC47

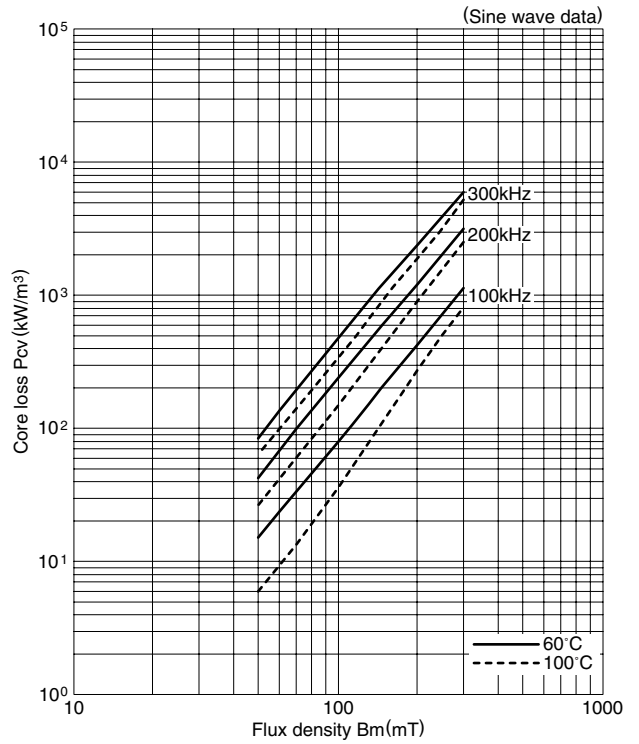

Material: PC33

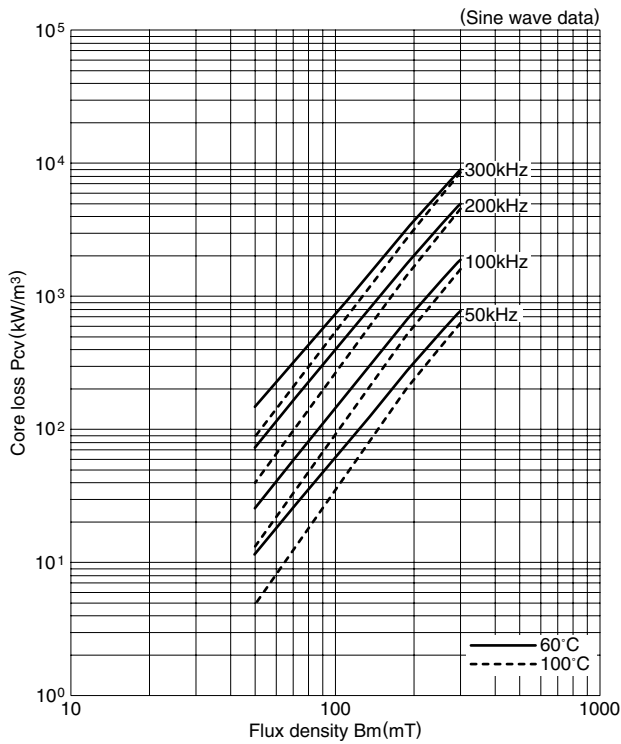

Material: PC95

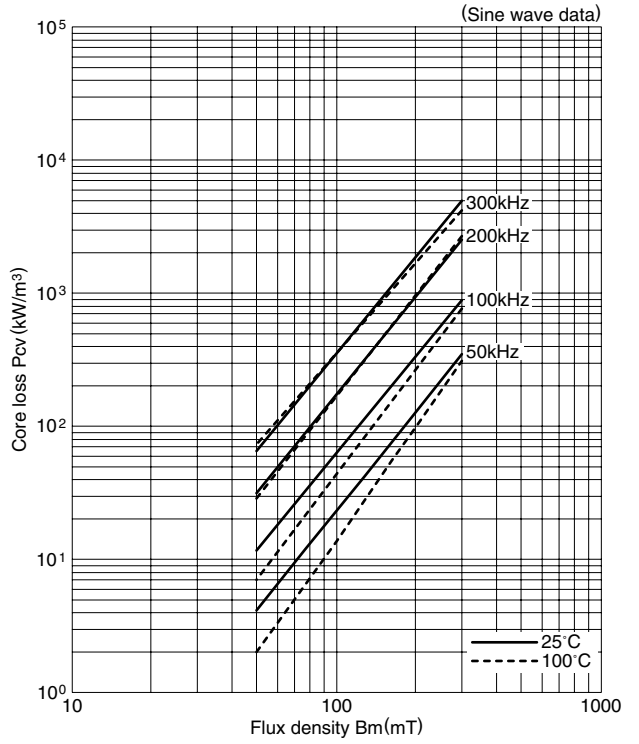

• All specifications are subject to change without notice.



### Temperature Dependence of Core Loss (Typical)

Material: PC40 (Frequency: 100kHz)

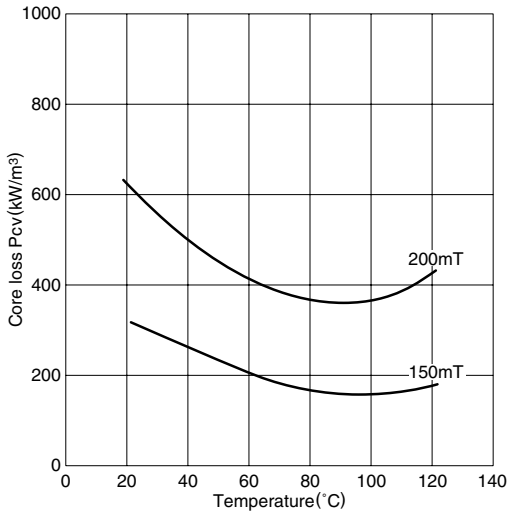

Material: PC44 (Frequency: 100kHz)

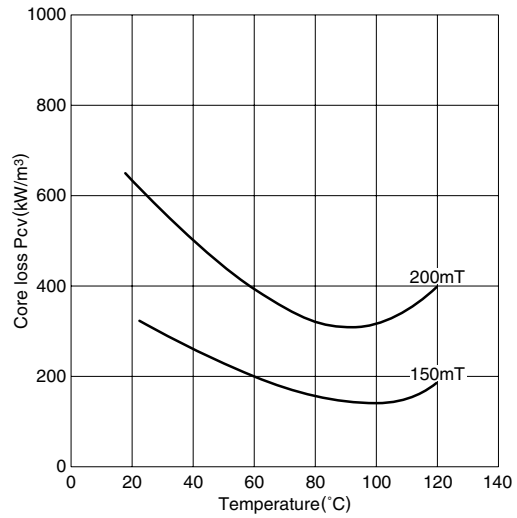

Test core: Toroidal  
OD=31mm  
TH=8mm  
ID=19mm

Material: PC50

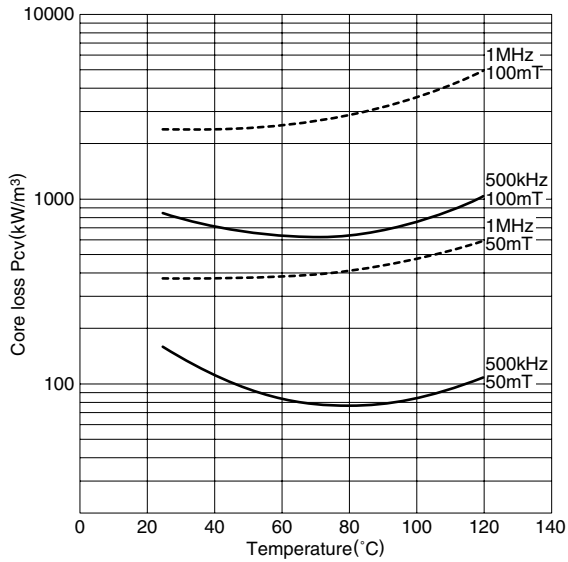

Material: PC47

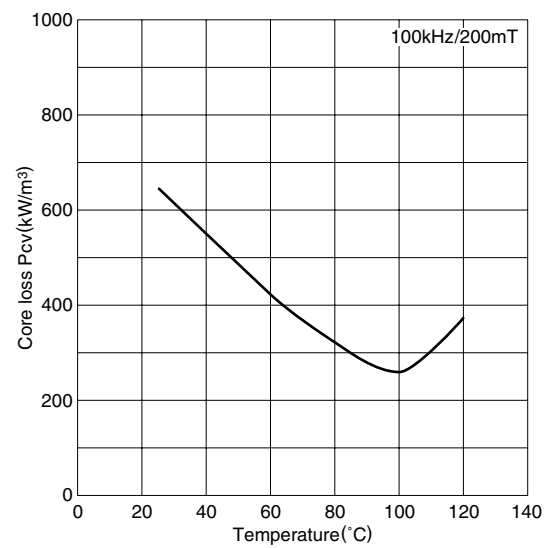

Material: PC33

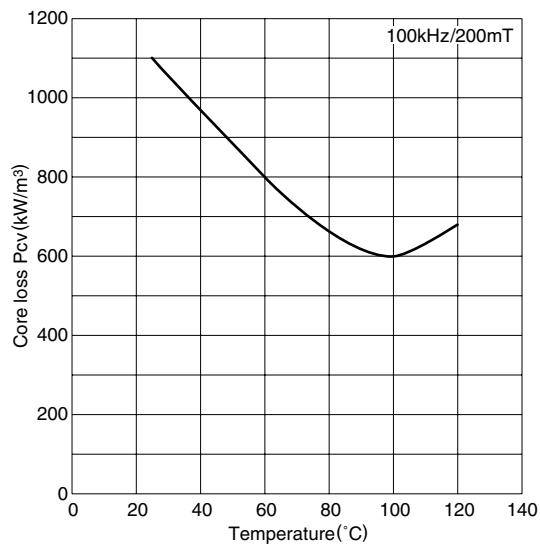

Material: PC95, PC45, PC46

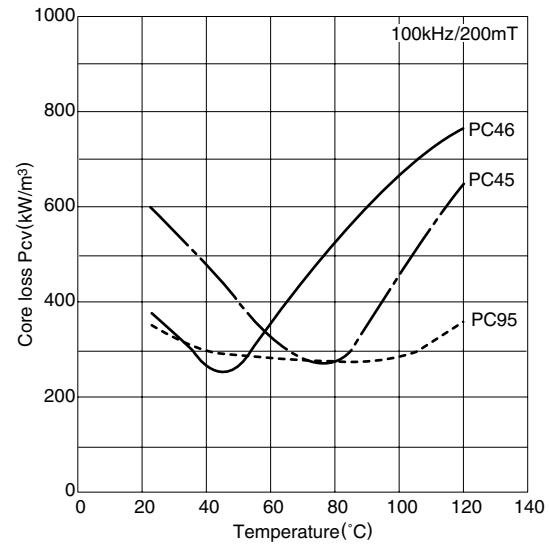

• All specifications are subject to change without notice.

### Magnetization Curves (Typical)

#### HS52

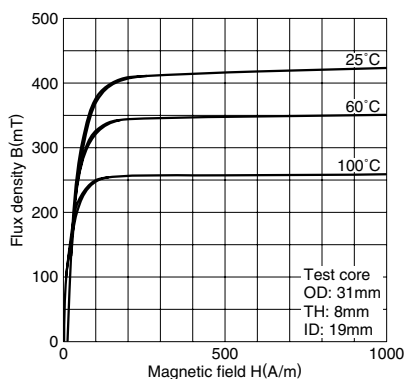

#### HS72

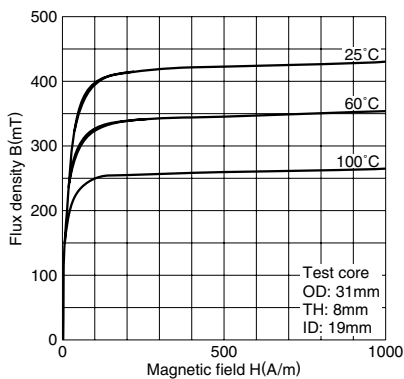

#### HS10

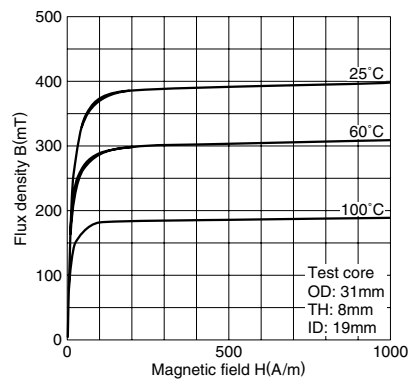

### $\mu_i$ vs. Temperature Characteristics (Typical)

#### PC40

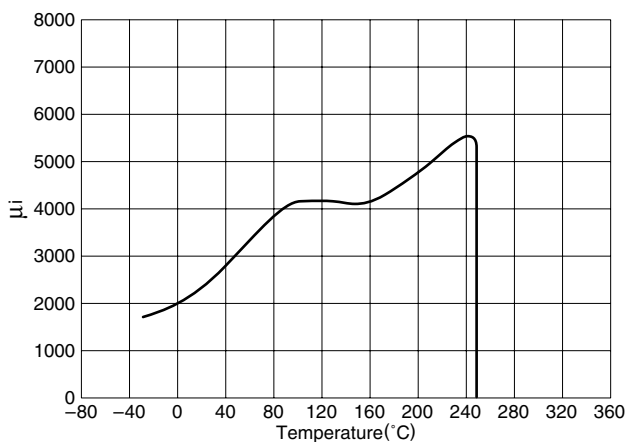

#### HS52

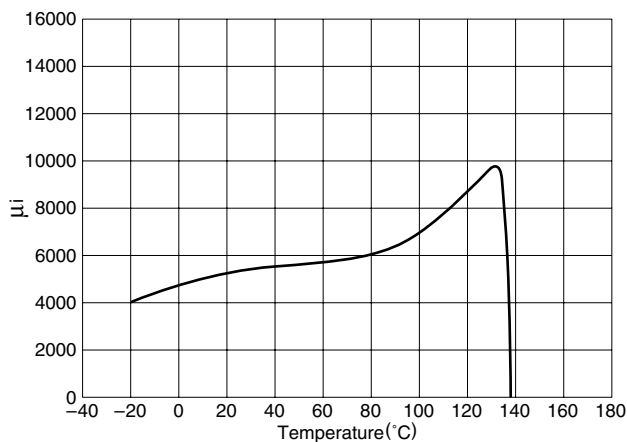

#### PC44

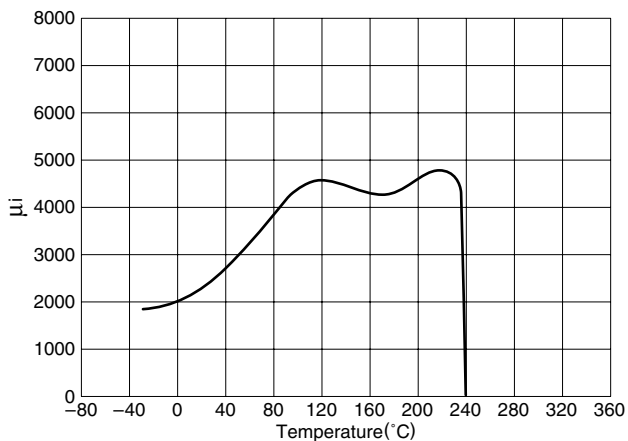

#### HS72

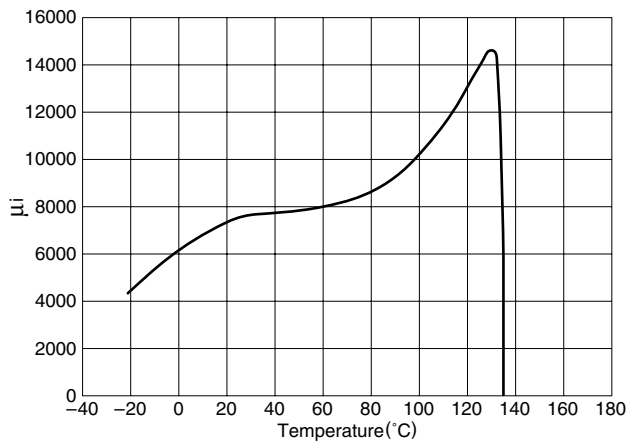

• All specifications are subject to change without notice.

### $\mu_i$ vs. Temperature Characteristics (Typical)

**PC50**

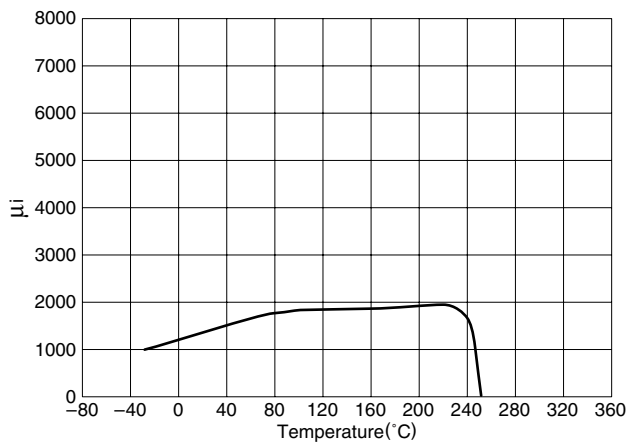

**HS10**

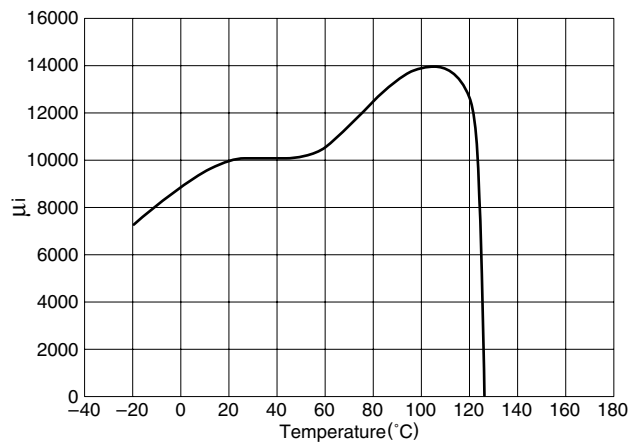

Test core: OD=31mm  
TH=8mm  
ID=19mm

**PC47**

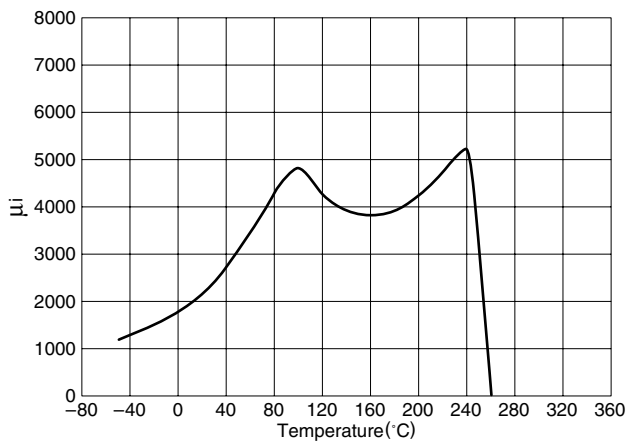

**PC45**

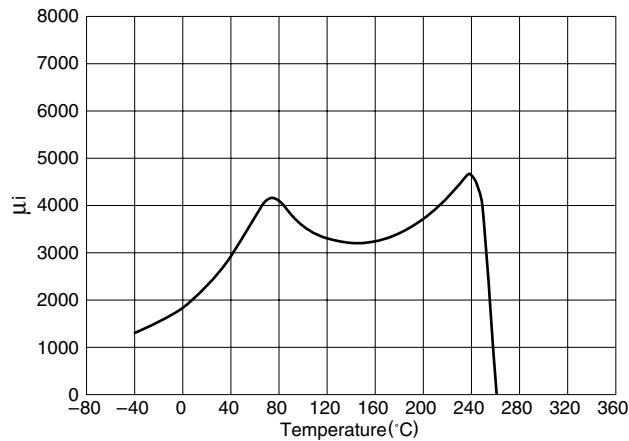

**PC46**

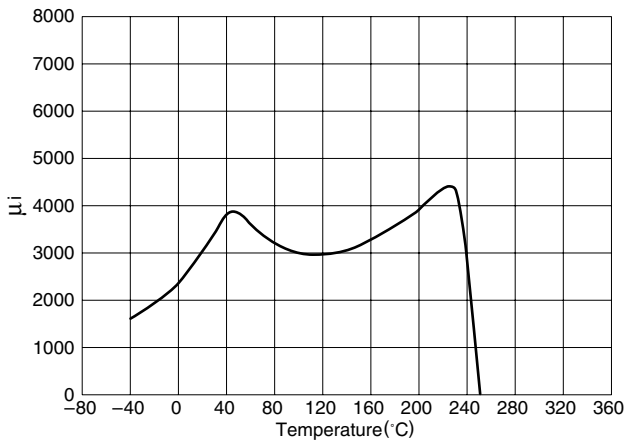

**PC95**

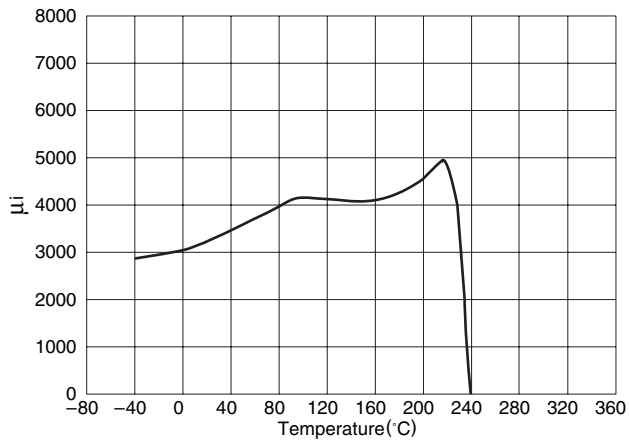

• All specifications are subject to change without notice.

## WIDE TEMPERATURE RANGE, LOW LOSS POWER MATERIAL PC95

Based on TDK's ferrite technologies, PC95 is a high-performance ferrite material that achieves low loss over a wide range of temperatures.

This material delivers the same level of saturated magnetic flux density as our existing PC44 and also delivers minimal loss (under  $350\text{kW/m}^3$ ) at temperatures ranging from 25 to  $120^\circ\text{C}$ .

PC95 can be used at a near-optimum state regardless of temperature. Owing to this characteristic, transformers based on the material PC95 are optimally suited for use in DC to DC converters in electric vehicle applications, such as HEVs and FCEVs, in which components are exposed to a wide range of temperatures. It can also be used in switching power supply transformers.

### FEATURES

- Low loss:  $<350\text{kW/m}^3$  (100kHz, 200mT) from 25 to  $120^\circ\text{C}$ .
- If used in DC to DC converters for electric vehicles, fuel efficiency can be improved due to the improved power efficiency over a wide temperature ranges.
- The materials offer about the same saturation magnetic flux density as PC44 from room temperature up to high temperatures.
- The materials can be shaped into standard as well as original shapes.

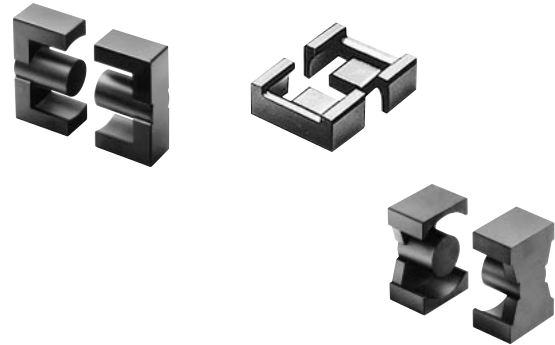

### APPLICATIONS

- DC to DC converters for automobiles
- Main transformers for various switching power supplies
- Inverter transformers for LCD backlight
- AC adapters and chargers

### MATERIAL CHARACTERISTICS

Material	PC95(NEW)		PC44
	25°C	350	600
Core loss P <sub>cv</sub> kW/m <sup>3</sup> [100kHz, 200mT]	80°C	280	320
	120°C	350	400

### CORE LOSS vs. TEMPERATURE CHARACTERISTICS

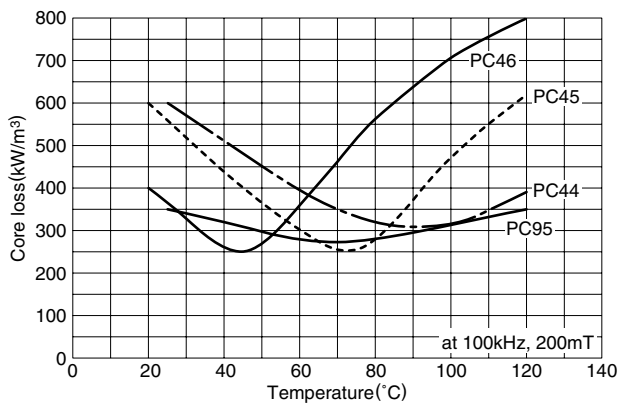

## LOW LOSS FERRITE MATERIAL PC47

PC47 has the best properties for transformers of power supplies, adapters and chargers.

The core loss and saturation magnetic flux density of PC47 are far better than PC44 and PC40 which are currently in use.

### FEATURES

- Core loss: 250kW/m<sup>3</sup> at 100kHz, 200mT, 100°C.
- Low core loss at wide frequency range 100kHz to 300kHz.
- Higher saturation flux density than PC44.

### APPLICATIONS

- Switching power supplies
- Adapters and chargers for notebook type pc
- CCFL LCD backlight

### MATERIAL CHARACTERISTICS

Material			PC47	PC44	PC40
Initial permeability	$\mu$	25°C	2500±25%	2400±25%	2300±25%
Core loss volume density [100kHz, 200mT]	P <sub>cv</sub>	kW/m <sup>3</sup>	25°C	600	600
			60°C	400	400
			100°C	250	300
Saturation magnetic flux density [1000A/m]	B <sub>s</sub>	mT	25°C	530	510
			100°C	420	390
Remanent flux density	B <sub>r</sub>	mT	25°C	180	110
			100°C	60	60
Curie temperature	T <sub>c</sub>	°C	min. 230	215	215
Density	db	kg/m <sup>3</sup>	4.9×10 <sup>3</sup>	4.8×10 <sup>3</sup>	4.8×10 <sup>3</sup>

### P<sub>cv</sub> TEMPERATURE DEPENDENCE CHARACTERISTICS (Typical)

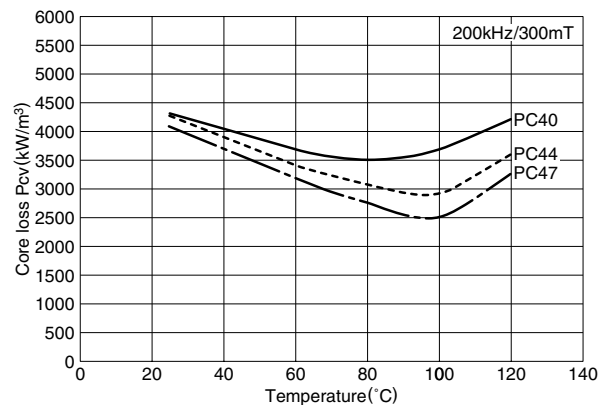
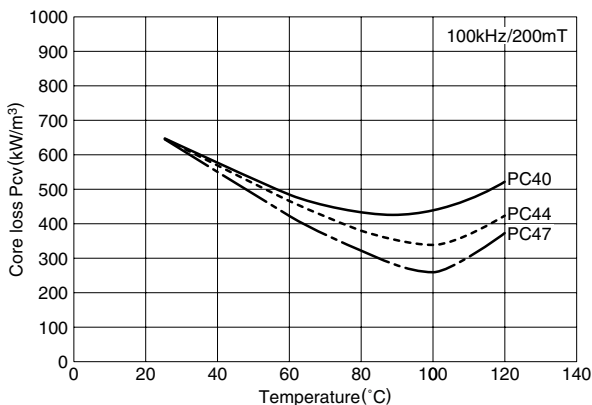

### B<sub>s</sub> and B<sub>r</sub> TEMPERATURE DEPENDENCE CHARACTERISTICS (Typical)

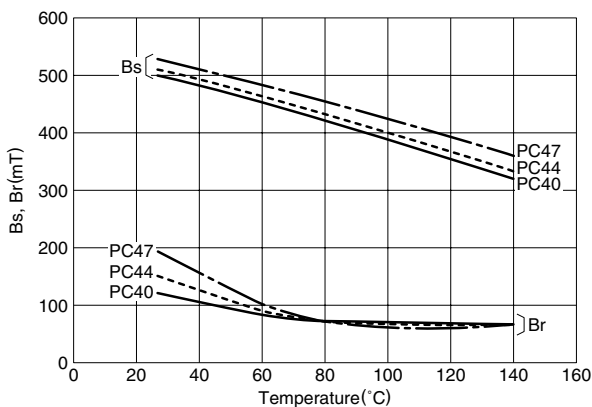

### $\mu_i$ vs. FREQUENCY CHARACTERISTICS (Typical)

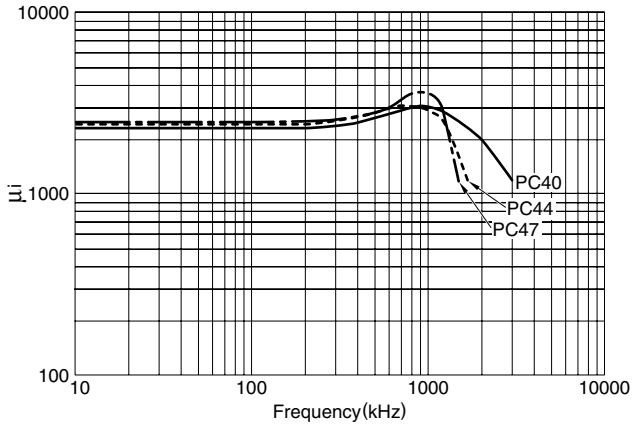

### $\mu_i$ vs. TEMPERATURE CHARACTERISTICS (Typical)

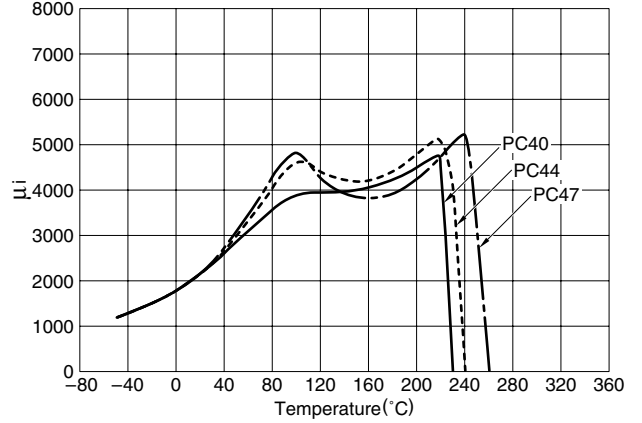

### MAGNETIZATION CURVES (Typical)

MATERIAL:PC47

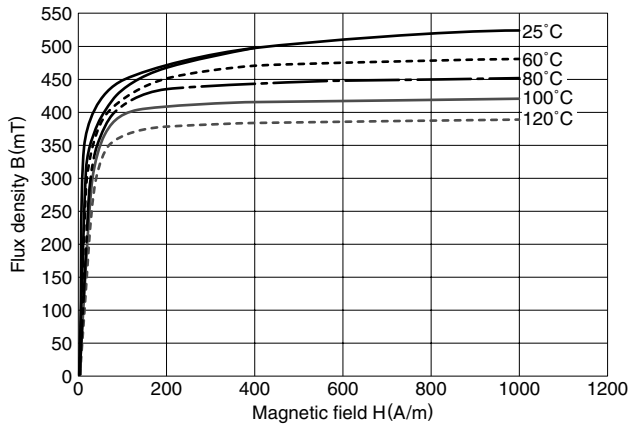

### $\mu_a$ TEMPERATURE DEPENDENCE CHARACTERISTICS (Typical)

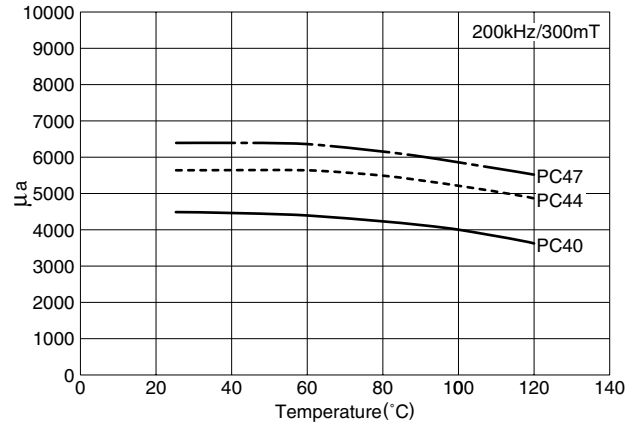

• All specifications are subject to change without notice.

## LOW LOSS FERRITE MATERIALS PC45 AND PC46

In recent years, with the advent of notebook type pc, VCR's, digital camera's and mobile communication devices, technological demands have risen for higher performance CCFL LCD backlight units that have smaller sizes, lower profiles and higher efficiency.

The PC45 and PC46 are materials developed to achieve higher efficiency in designing minimize core loss at practical temperature ranges (PC45: 60 to 80°C and PC46: 40 to 50°C) and high saturation flux density.

They are also suitable for the transformers of DC to DC converters and adapters of notebook type pc.

### APPLICATIONS

- Switching power supplies
- Adapters and chargers for notebook type pc
- CCFL LCD backlight

### MATERIAL CHARACTERISTICS

Material			PC45	PC46	PC44	
Initial permeability	$\mu_i$	25°C	2500±25%	3200±25%	2400±25%	
Core loss volume density [100kHz, 200mT]	Pcv	kW/m <sup>3</sup>	25°C	570	350	600
			60°C	250(75°C)	250(45°C)	400
			100°C	460	660	300
Saturation magnetic flux density [1000A/m]	Bs	mT	25°C	530	530	510
			100°C	420	410	390
Remanent flux density	Br	mT	25°C	120	80	110
			100°C	80	115	60
Curie temperature	Tc	°C	min.	230	230	215
Density	db	kg/m <sup>3</sup>		4.8×10 <sup>3</sup>	4.8×10 <sup>3</sup>	4.8×10 <sup>3</sup>

### Pcv TEMPERATURE DEPENDENCE CHARACTERISTICS (Typical)

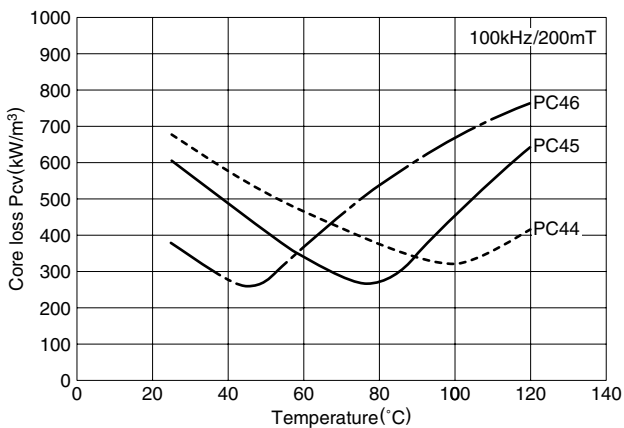

### Bs and Br TEMPERATURE DEPENDENCE CHARACTERISTICS (Typical)

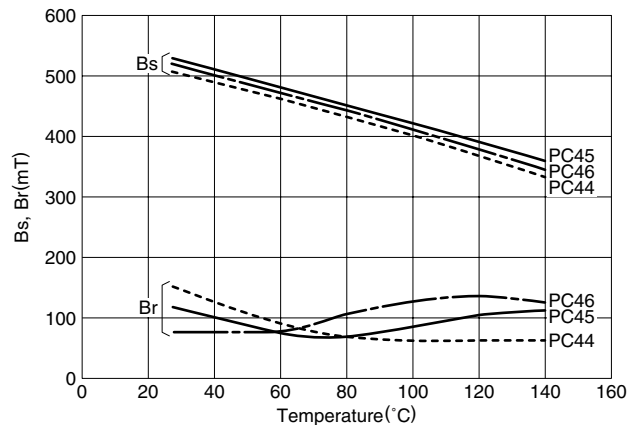

### $\mu_i$ vs. FREQUENCY CHARACTERISTICS (Typical)

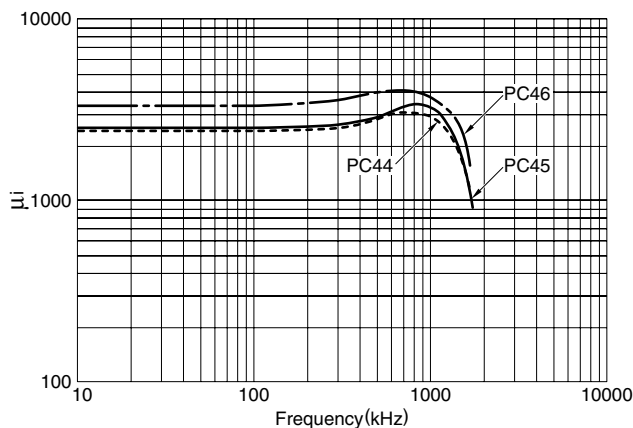

### $\mu_i$ vs. TEMPERATURE CHARACTERISTICS (Typical)

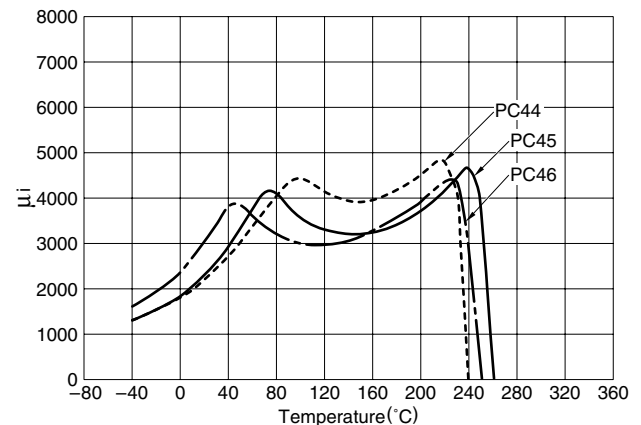

### MAGNETIZATION CURVES

MATERIAL:PC45

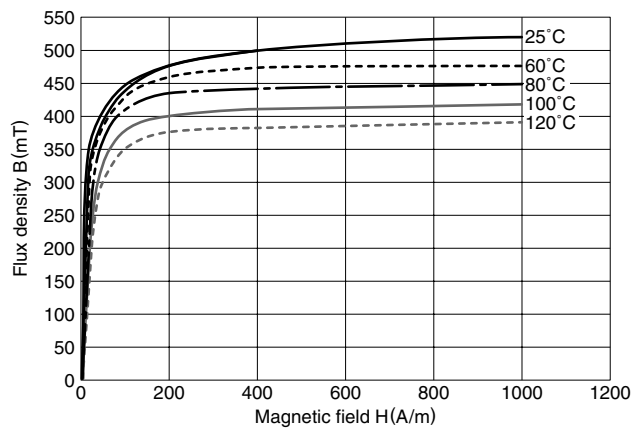

MATERIAL:PC46

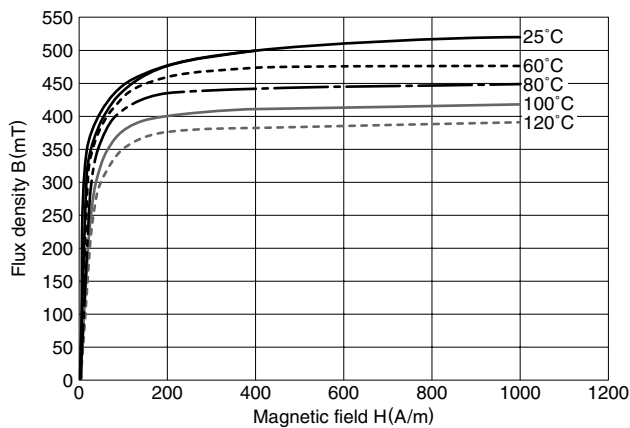



## HIGH SATURATION FLUX DENSITY MATERIAL FOR CHOKE COIL PC33

PC33 has the best properties for smoothing choke coil of power supplies.

The saturation magnetic flux density of PC33 is far better than PC44 and PC40 which are currently in use.

### FEATURES

- Higher saturation flux density than PC44 and PC40.
- Most suitable ferrite material for choke coils.
- Maintain high saturation magnetic flux density at high temperature.

### APPLICATIONS

- Power choke coils for switching power supplies
- Power choke coils for notebook type pc

### MATERIAL CHARACTERISTICS

Material				PC33	PC44	PC40
Saturation magnetic flux density [1000A/m]	Bs	mT	25°C	510	510	510
			100°C	440	390	390
Initial permeability	$\mu$		25°C	1400±25%	2400±25%	2300±25%
Core loss volume density [100kHz, 200mT]	P <sub>cv</sub>	kW/m <sup>3</sup>	25°C	1100	600	600
			60°C	800	400	450
			100°C	600	300	410
Curie temperature	T <sub>c</sub>	°C	min.	290	215	215
Density	db	kg/m <sup>3</sup>		4.8×10 <sup>3</sup>	4.8×10 <sup>3</sup>	4.8×10 <sup>3</sup>

### P<sub>cv</sub> TEMPERATURE DEPENDENCE CHARACTERISTICS (Typical)

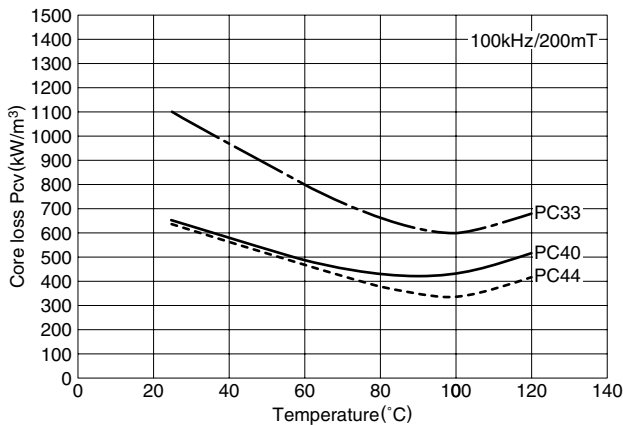

### B<sub>s</sub> TEMPERATURE DEPENDENCE CHARACTERISTICS (Typical)

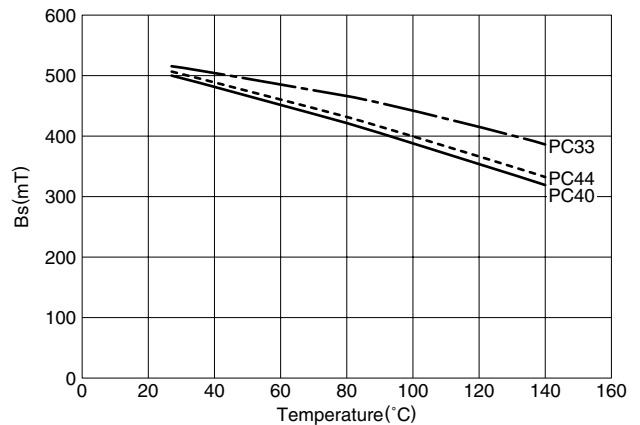

## FERRITE MATERIALS FOR LAN PULSE TRANSFORMERS DNW45

With the growing popularity of high-speed Ethernet, the demand for ferrite material that is optimally suited for pulse transformers in LAN systems is rising. In particular, LAN systems that are subjected to the harsh operating environments found in industrial applications are required to operate at wider temperature ranges compared to existing materials.

To meet such demands, TDK has developed the DNW45, a product dedicated to small toroidal forms used in high-speed LANs, which delivers high inductance and excellent DC superposition characteristics at a wide temperature range (−40 to +85°C).

### FEATURES

- Delivers high inductance over a wide temperature range (−40 to +85°C).
- This ferrite material delivers excellent DC superposition characteristics and was designed for small toroidal cores.
- DC superposition characteristics in the −40 to +85°C temperature range has been improved by 23% compared to DN45, one of previous materials.

### APPLICATIONS

Ferrite core for pulse transformers in Ethernet (100Base-T) LAN systems.

- Please consult us for on-vehicle applications.

### MATERIAL CHARACTERISTICS

#### COMPARISON TO PREVIOUS MATERIAL

Material				DNW45	HP5
Initial permeability	$\mu_i$		25°C	4200±25%	5000±25%
Relative loss factor	$\tan\delta/\mu_i$	$\times 10^{-6}$	25°C, 10kHz	<3.5	<3.5
Saturation magnetic flux density	$B_s$	mT	25°C, 1000A/m	450	400
Curie temperature	$T_c$	°C	min.	150	140
Density	db	kg/m <sup>3</sup>		$4.85 \times 10^3$	$4.8 \times 10^3$
Electrical resistivity	$\rho_v$	$\Omega \cdot m$	25°C	0.65	0.15

- Measured with toroidal core(OD10×ID5×T2.5mm).

- Various toroidal cores of small sizes are available. Please contact us for details.

#### $\mu_i$ vs. TEMPERATURE CHARACTERISTICS

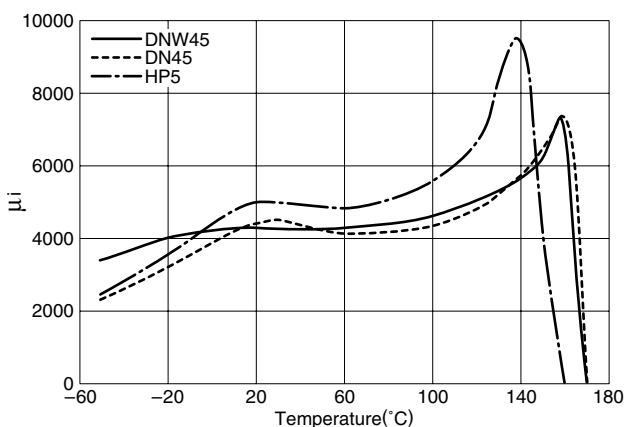

#### $\mu_\Delta$ vs. TEMPERATURE CHARACTERISTICS

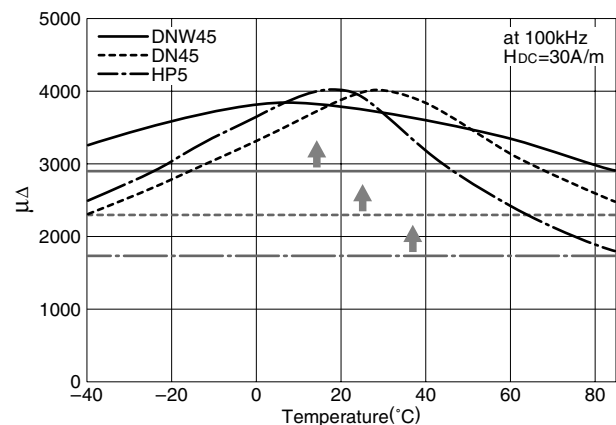

## LOW THD MATERIALS FOR xDSL MODEM TRANSFORMERS DN40 AND DN70

The use of xDSL technique becomes wide spread as a high broad-band access to the internet. In order to utilize such network access as sufficient as possible, low THD (Total Harmonic Distortion) of transformer for xDSL modem is quite important to transfer the significant signals.

Materials DN40 and DN70, TDK achieved such requirements recently, are developed to meet low THD over a wide temperature range(0 to 85°C) and wide frequency range( $\geq 5$ kHz).

Therefore, They are suitable for the high performance transformer design for xDSL modem applications.

Standardization of AL-value will help you to select the optimum core at the transformer design.

### FEATURES

- Meet low THD over a wide temperature range(0 to 85°C) and wide frequency range ( $\geq 5$ kHz).

### APPLICATIONS

- Transformer for xDSL modem

### APPLIED CORE TYPE AND AL-value

Core	Type	AL-value
EP	EP7	40, 63, 100, 160, 250
	EP10	40, 63, 100, 160, 250
	EP13	63, 100, 160, 250, 400, 500

### MATERIAL CHARACTERISTICS

Material			DN70	DN40
Initial permeability	$\mu_i$	25°C	7500 $\pm$ 25%	4000 $\pm$ 25%
Relative loss factor [10kHz]	$\tan\delta/\mu_i$	$\times 10^{-6}$ 25°C	<2.0	<2.5
Temperature factor of initial permeability	$\alpha\mu_{ir}$	-30 to +20°C 20 to 70°C	-0.5 to +1.5 -0.5 to +1.5	-0.5 to 2.0 -0.5 to 2.0
Saturation magnetic flux density [1000A/m]	$B_s$	mT 25°C	390	405
Hysteresis material constant [25°C, 1.5 to 3.0mT, 10kHz]	$\eta_B$	$\frac{10^{-6}}{\text{mT}}$	<0.2	<0.8
Curie temperature	$T_c$	°C min.	105	130
Density	$\rho_b$	kg/m <sup>3</sup>	5.0 $\times 10^3$	4.8 $\times 10^3$
Electrical resistivity	$\rho_v$	$\Omega \cdot \text{m}$	0.3	1.0

• Unless otherwise specify the tolerance, the values are shown as a typical.

### THD TEMPERATURE DEPENDENCE CHARACTERISTICS (Typical) $\mu_i$ vs. TEMPERATURE CHARACTERISTICS (Typical)

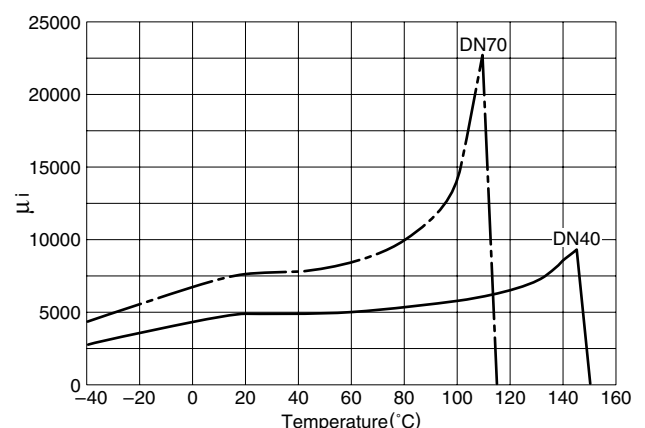
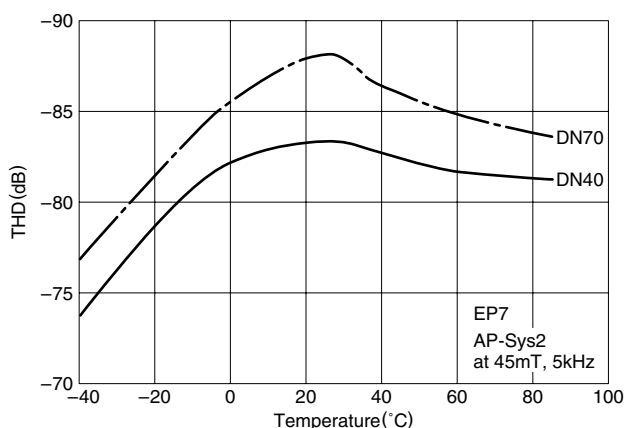

# E SERIES

## Cores

- EI12.5 to EI60
- EE8 to EE62.3/62/6
- EF12.6 to EF32
- EER25.5 to EER49
- ETD19 to ETD49

## Bobbins

- BE8 to BE62.3
- BEER25.5 to BEER49
- BETD19 to BETD24

## Accessories

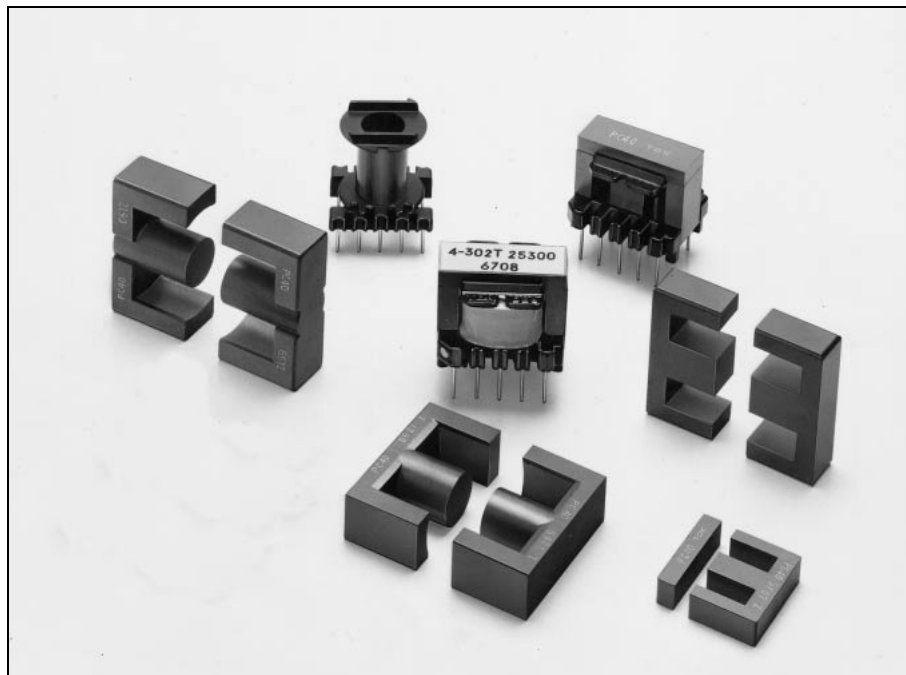

## Ordering Code System

### Cores

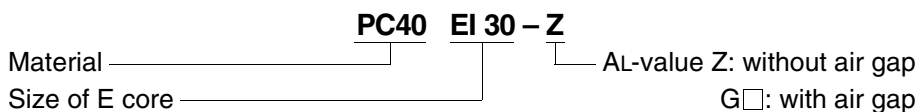

### Bobbins

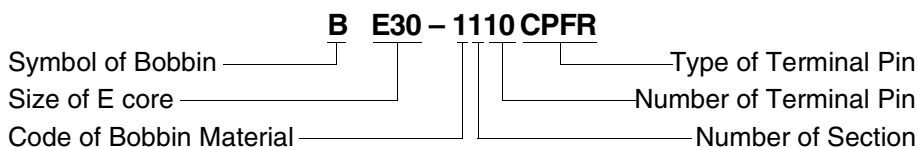

### Accessories

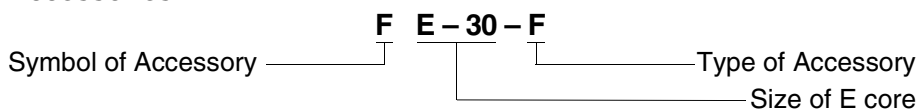

## EI CORES

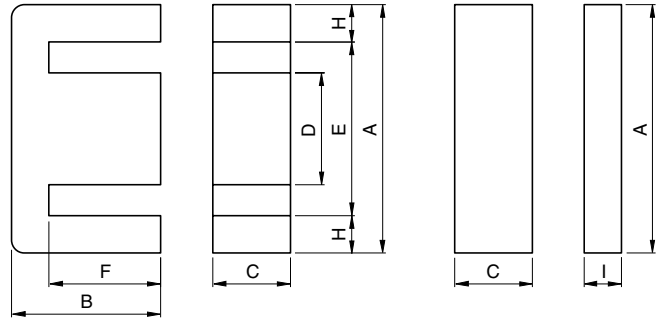
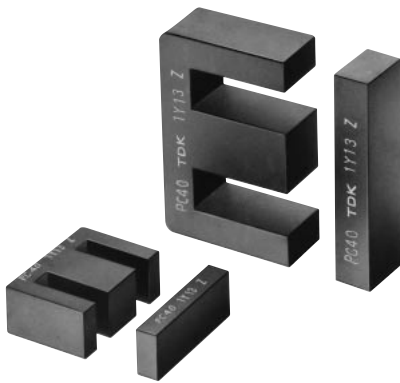

Part No.	JIS	Dimensions in							
		mm		inches					
		A	B	C	D	E	F	H	I
PC40EI12.5-Z	JIS	12.4±0.3	7.4±0.1	4.85±0.15	2.4±0.1	8.8	5.1±0.1	1.6	1.5±0.1
	FEI 12.5	.488±.012	.291±.004	.191±.006	.094±.004	.346	.201±.004	.063	.059±.004
PC40EI16-Z	JIS	16.0±0.3	12.2±0.2	4.8±0.2	4.0±0.2	11.6	10.2±0.2	2.05	2.0±0.2
	FEI 16	.630±.012	.480±.008	.189±.008	.157±.008	.457	.402±.008	.081	.079±.008
PC40EI19-Z		20.0±0.3	13.55±0.25	5.0±0.2	4.55±0.15	14.3	11.15±0.15	2.75	2.3±0.1
		.787±.012	.533±.010	.197±.008	.179±.006	.563	.439±.006	.108	.091±.004
PC40EI22-Z		22.0±0.3	14.55±0.25	5.75±0.25	5.75±0.25	13.0	10.55±0.25	4.5	4.5±0.2
		.866±.012	.573±.010	.226±.010	.226±.010	.512	.415±.010	.177	.177±.008
PC40EI22/19/6-Z	JIS	22.0±0.4	14.7±0.2	5.75±0.25	5.75±0.25	15.75	10.7±0.2	3.0	4.0±0.2
	FEI 22	.866±.016	.579±.008	.226±.010	.226±.010	.620	.421±.008	.118	.157±.008
PC40EI25-Z		25.3±0.5	15.55±0.25	6.75±0.25	6.5±0.3	19.0	12.35±0.25	3.0	2.7±0.2
		.996±.020	.612±.010	.266±.010	.256±.012	.748	.486±.010	.118	.106±.008
PC40EI28-Z	JIS	28.0 <sup>+0.7</sup> <sub>-0.5</sub>	16.75±0.25	$\frac{10.6±0.2}{.417±.008}$ (E core)	7.2±0.3	18.4	12.25±0.25	4.5	3.5±0.3
	FEI 28	1.102 <sup>+0.028</sup> <sub>-.020</sub>	.659±.010	$\frac{10.7±0.3}{.421±.012}$ (I core)	.283±.012	.724	.482±.010	.177	.138±.012

Part No.	Effective parameter				Electrical characteristics			Wt (g)	Bobbin item
	C <sub>1</sub> (mm <sup>-1</sup> )	A <sub>e</sub> (mm <sup>2</sup> )	l <sub>e</sub> (mm)	V <sub>e</sub> (mm <sup>3</sup> )	AL-value (nH/N <sup>2</sup> ) <sup>*</sup>		Core loss (W) max. 100kHz, 200mT, 100°C		
					Without air gap	With air gap			
PC40EI12.5-Z	1.48	14.4	21.3	308	1200±25%	63±7% 100±10%	0.12	1.9	BE12.5-1110CPFR
PC40EI16-Z	1.75	19.8	34.6	685	1100±25%	80±7% 160±10%	0.31	3.3	BE16-116CPFR BE16-118CPHFR BE16-1110CPNFR
PC40EI19-Z	1.65	24.0	39.6	950	1400±25%	80±7% 160±10%	0.42	5.1	BE19-116CPFR BE19-118CPHFR BE-19-5116
PC40EI22-Z	0.936	42.0	39.3	1650	2400±25%	125±7% 250±10%	0.6	9.8	BE22-1110CPFR BE22-118CPFR BE-22-5116
PC40EI22/19/6-Z	1.13	37.0	41.8	1550	2000±25%	125±7% 250±10%	0.64	8.5	BE22/19/6-118CPFR
PC40EI25-Z	1.15	41.0	47.0	1930	2140±25%	125±7% 250±10%	0.79	9.8	BE25-118CPFR BE-25-5116
PC40EI28-Z	0.56	86.0	48.2	4150	4300±25%	200±5% 400±7%	1.65	22	BE28-1110CPLFR

\* AL-value: 1kHz, 0.5mA, 100Ts

## EI CORES

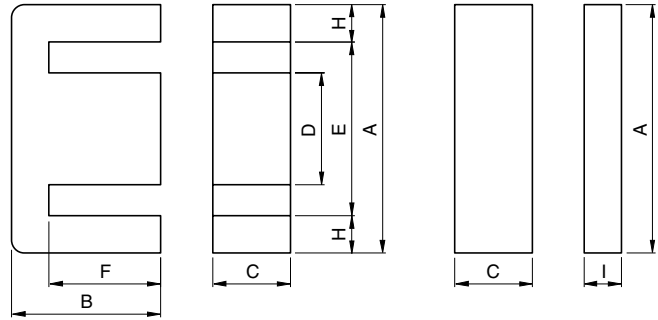
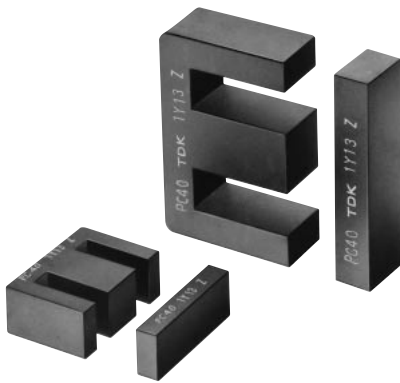

Part No.	JIS	Dimensions in							
		A	B	C	D	E min.	F	H	I
PC40EI30-Z	JIS	30.0 <sup>+0.7</sup> <sub>-0.4</sub>	21.25±0.25	10.7±0.3	10.7±0.3	19.7	16.25±0.25	5.0	5.5±0.2
	FEI 30	1.181 <sup>+0.028</sup> <sub>-0.016</sub>	.837±.010	.421±.012	.421±0.12	.776	.640±.010	.197	.217±.008
PC40EI33/29/13-Z	JIS	33.0 <sup>+0.8</sup> <sub>-0.5</sub>	23.75±0.25	12.7±0.3	9.7±0.3	23.4	19.25±0.25	4.45	5.0±0.3
	FEI 30	1.299 <sup>+0.031</sup> <sub>-0.020</sub>	.935±.010	.500±.012	.382±.012	.921	.758±.010	.175	.197±.012
PC40EI35-Z	JIS	35.0±0.5	24.35±0.15	10.0±0.3	10.0±0.3	24.5	18.25±0.15	5.0	4.6±0.3
	FEI 35	1.378±.020	.959±.006	.394±.012	.394±.012	.965	.719±.006	.197	.181±.012
PC40EI40-Z	JIS	40.0±0.5	27.25±0.25	11.65±0.35	11.65±0.35	27.2	20.25±0.25	6.2	7.5±0.3
	FEI 40	1.575±.020	1.073±.010	.459±.014	.459±.014	1.071	.797±.010	.244	.295±.012
PC40EI50-Z	JIS	50.0 <sup>+1.2</sup> <sub>-0.7</sub>	33.35±0.35	14.6±0.4	14.6±0.4	33.5	24.75±0.25	7.7	9.0±0.3
	FEI 50	1.969 <sup>+0.047</sup> <sub>-0.028</sub>	1.313±.014	.575±.016	.575±.016	1.319	.974±.010	.303	.354±.012
PC40EI60-Z	JIS	60.0 <sup>+1.4</sup> <sub>-0.8</sub>	35.85±0.35	15.6±0.4	15.6±0.4	43.6	27.85±0.35	7.7	8.5±0.3
	FEI 60	2.362 <sup>+0.055</sup> <sub>-0.031</sub>	1.411±.014	.614±.016	.614±.016	1.717	1.096±.014	.303	.335±.012

Part No.	Effective parameter				Electrical characteristics			Wt (g)	Bobbin item
	C <sub>1</sub> (mm <sup>-1</sup> )	A <sub>e</sub> (mm <sup>2</sup> )	∅ <sub>e</sub> (mm)	V <sub>e</sub> (mm <sup>3</sup> )	AL-value (nH/N <sup>2</sup> )*		Core loss (W) max. 100kHz, 200mT, 100°C		
					Without air gap	With air gap			
PC40EI30-Z	0.522	111	58.0	6440	4690±25%	200±5% 400±7%	3.1	34	BE30-1110CPFR BE30-1112CPFR BE-30-5112
PC40EI33/29/13-Z	0.567	119	67.5	8030	4400±25%	200±5% 400±7%	3.5	41	BE33-1112CPLFR
PC40EI35-Z	0.664	101	67.1	6780	3800±25%	200±5% 400±7%	2.85	36	BE35-1112CPLFR
PC40EI40-Z	0.520	148	77.0	11400	4860±25%	200±5% 400±7%	4.8	60	BE40-1112CPFR BE40-1112CPNFR BE-40-5112
PC40EI50-Z	0.409	230	94.0	21620	6110±25%	250±5% 500±7%	9.2	115	BE50-1112CPFR BE-50-5112
PC40EI60-Z	0.441	247	109	26900	5670±25%	250±5% 500±7%	12.5	139	BE60-1112CPFR BE-60-5112

\* AL-value: 1kHz, 0.5mA, 100Ts

## EE AND EF CORES

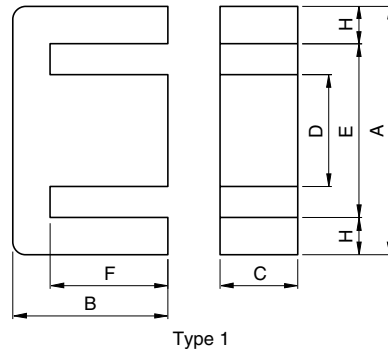
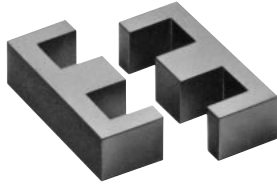
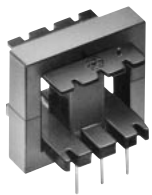

Type 1

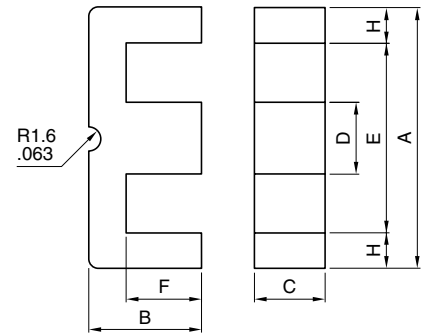

Type 2

Part No.	U.S. lam. cores, DIN standard JIS	Type	Dimensions in						
			mm		inches				
			A	B	C	D	E	F	H
PC40EE8-Z	JIS FEE 8.3	1	8.3±0.2	4.0±0.1	3.6±0.2	1.85±0.15	6.0	3.0±0.1	1.0
			.327±.008	.157±.004	.142±.008	.073±.006	.236	.118±.004	.039
PC40EE10/11-Z	JIS FEE 10.2	1	10.2±0.2	5.5±0.1	4.75±0.15	2.45±0.15	7.7	4.20±0.15	1.1
			.402±.008	.217±.004	.187±.006	.096±.006	.303	.165±.006	.043
PC40EF12.6-Z	DIN 41985	1	12.7±0.4	6.4±0.1	3.6±0.2	3.65±0.15	8.8	4.65±0.15	1.83
			.500±.016	.252±.004	.142±.008	.144±.006	.346	.183±.006	.072
PC40EE13-Z		1	13.0±0.2	6.00±0.15	6.15±0.15	2.75±0.15	10.0	4.6±0.1	1.4
			.512±.008	.236±.006	.242±.006	.108±.006	.394	.181±.004	.055
PC40EE16-Z	JIS FEE 16A	1	16.0±0.3	7.15±0.15	4.8±0.2	4.0±0.2	11.7	5.1±0.2	2.0
			.630±.012	.281±.006	.189±.008	.157±.008	.461	.201±.008	.079
PC40SEE16-Z		1	16.0±0.3	7.15±0.15	6.8±0.2	3.18±0.18	12.5	5.5±0.1	1.6
			.630±.012	.281±.006	.268±.008	.125±.007	.492	.217±.004	.063
PC40EF16-Z	DIN 41985	1	16.1±0.6	8.05±0.15	4.5±0.2	4.55±0.15	11.3	5.9±0.2	2.2
			.634±.024	.317±.006	.177±.008	.179±.006	.445	.232±.008	.087
PC40EE19-Z	JIS FEE 19A	1	19.1±0.3	7.95±0.15	5.0±0.2	4.55±0.15	14.2	5.6±0.1	2.3
			.752±.012	.313±.006	.197±.008	.179±.006	.559	.220±.004	.091
PC40EE19/16-Z	U.S. EE-187	1	19.29±0.32	8.1±0.18	4.75±0.13	4.75±0.08	14.05	5.715±0.125	2.46
			.759±.013	.319±.007	.187±.005	.187±.003	.553	.225±.005	.097

Part No.	Effective parameter				Electrical characteristics			Wt (g)	Bobbin item
	C <sub>1</sub> (mm <sup>-1</sup> )	A <sub>e</sub> (mm <sup>2</sup> )	ℓ <sub>e</sub> (mm)	V <sub>e</sub> (mm <sup>3</sup> )	AL-value (nH/N <sup>2</sup> ) <sup>*</sup>		Core loss (W) max. 100kHz, 200mT, 100°C		
					Without air gap	With air gap			
PC40EE8-Z	2.75	7.0	19.2	134	610±25%	40±7% 63±10%	0.06	0.7	BE8-116CPHFR
PC40EE10/11-Z	2.16	12.1	26.1	315	850±25%	40±7% 63±10%	0.14	1.5	BE10-118CPSFR
PC40EF12.6-Z	2.28	13.0	29.6	385	810±25%	63±7% 100±10%	0.17	2.0	—
PC40EE13-Z	1.77	17.1	30.2	517	1130±25%	63±7% 100±10%	0.235	2.7	BE13-1110CPSFR
PC40EE16-Z	1.82	19.0	34.5	656	1140±25%	80±7% 160±10%	0.31	3.3	BE16-116CPFR BE16-118CPHFR BE16-1110CPNFR
PC40SEE16-Z	1.69	21.7	36.6	795	1240±25%	80±7% 160±10%	0.37	4.1	BES16-1110CPSFR
PC40EF16-Z	1.87	20.1	37.6	754	1100±25%	63±7% 100±10%	0.32	3.9	—
PC40EE19-Z	1.71	23.0	39.4	906	1250±25%	80±7% 160±10%	0.42	4.8	BE19-116CPFR BE19-118CPHFR BE-19-5116
PC40EE19/16-Z	1.75	22.4	39.1	876	1350±25%	80±7% 160±10%	0.41	4.8	

\* AL-value: 1kHz, 0.5mA, 100Ts

## EE AND EF CORES

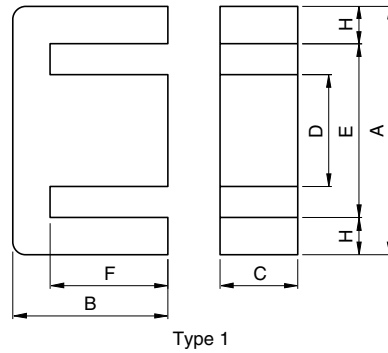
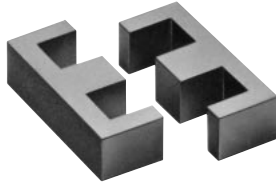
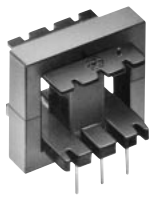

Type 1

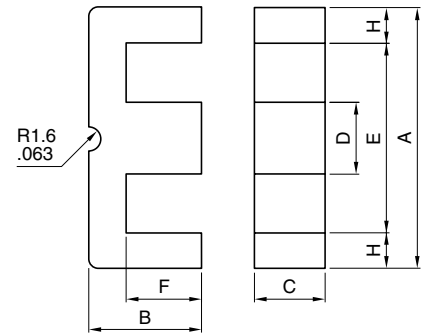

Type 2

Part No.	U.S. lam. cores, DIN standard JIS	Type	Dimensions in		C	D	E	F	H
			mm	inches					
PC40EE20/20/5-Z	DIN 41295	2	20.15±0.55	10.0±0.2	5.1±0.2	5.0±0.2	12.8	6.5±0.2	3.53
			.793±.022	.394±.008	.201±.008	.197±.008	.504	.256±.008	.139
PC40EF20-Z	DIN 41985	1	20.0±0.4	9.9±0.2	5.65±0.25	5.7±0.2	14.1	7.2±0.2	2.8
			.787±.016	.390±.008	.222±.010	.224±.008	.555	.283±.008	.110
PC40EE22-Z		1	22.0±0.3	9.35±0.15	5.75±0.25	5.75±0.25	13.0	5.35±0.15	4.3
			.866±.012	.368±.006	.226±.010	.226±.010	.512	.211±.006	.169
PC40EE25/19-Z	U.S. EE-24/25	1	25.4±0.5	9.46±0.19	6.29±0.19	6.35±0.25	18.55	6.41±0.19	3.11
			1.000±.020	.372±.007	.248±.007	.250±.010	.730	.252±.007	.122
PC40EF25-Z	DIN 41985	1	25.05±0.75	12.55±0.25	7.2±0.3	7.25±0.25	17.5	8.95±0.25	3.55
			.986±.030	.494±.010	.283±.012	.285±.010	.689	.352±.010	.140
PC40EE25.4-Z	JIS FEE 25.4A	1	25.4±0.76	9.66±0.15	6.35±0.25	6.35±0.25	18.5	6.48±0.15	3.18
			1.000±.030	.380±.006	.250±.010	.250±.010	.728	.255±.006	.125
PC40EE30-Z	JIS FEE 30A	1	30.0±0.5	13.15±0.15	10.7±0.3	10.7±0.3	19.7	8.15±0.15	5.0
			1.181±.020	.518±.006	.421±.012	.421±.012	.776	.321±.006	.197
PC40EE30/30/7-Z	DIN 41295	2	30.1±0.7	15.0±0.2	7.05±0.25	6.95±0.25	19.5	9.95±0.25	5.1
			1.185±.028	.591±.008	.278±.010	.274±.010	.768	.392±.010	.201

Part No.	Effective parameter				Electrical characteristics			Wt (g)	Bobbin item
	C <sub>1</sub> (mm <sup>-1</sup> )	A <sub>e</sub> (mm <sup>2</sup> )	l <sub>e</sub> (mm)	V <sub>e</sub> (mm <sup>3</sup> )	AL-value (nH/N <sup>2</sup> )*		Core loss (W) max. 100kHz, 200mT, 100°C		
					Without air gap	With air gap			
PC40EE20/20/5-Z	1.38	31.0	43.0	1340	1400±25%	100±7% 160±10%	0.51	7.5	—
PC40EF20-Z	1.34	33.5	44.9	1500	1570±25%	100±7% 160±10%	0.69	7.4	—
PC40EE22-Z	0.970	41.0	39.6	1620	2180±25%	125±7% 250±10%	0.61	8.8	BE22-1110CPFR BE22-118CPFR BE-22-5116
PC40EE25/19-Z	1.22	40.0	48.7	1950	2000±25%	100±7% 200±10%	0.86	9.1	—
PC40EF25-Z	1.11	51.8	57.8	2990	2000±25%	100±7% 160±10%	1.40	15	—
PC40EE25.4-Z	1.21	40.3	48.7	1963	2000±25%	125±7% 250±10%	0.90	10	—
PC40EE30-Z	0.529	109.0	57.7	6290	4690±25%	200±5% 400±7%	2.90	32	BE30-1110CPFR BE30-1112CPFR BE-30-5112
PC40EE30/30/7-Z	1.12	59.7	66.9	4000	2100±25%	160±5% 250±7%	1.51	22	—

\* AL-value: 1kHz, 0.5mA, 100Ts



## EE AND EF CORES

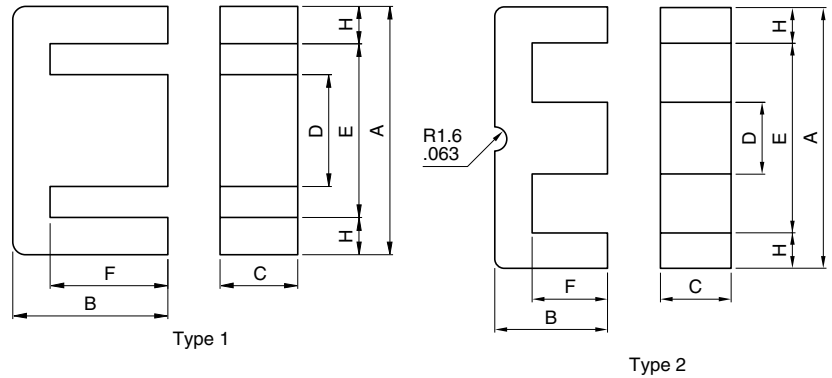
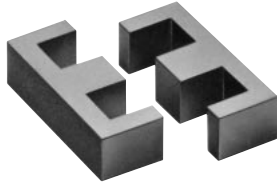
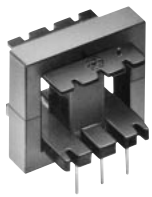

Part No.	U.S. lam. cores, DIN standard JIS	Type	Dimensions in							
			mm		inches					
			A	B	C	D	E min.	F	H	
PC40EF32-Z	DIN 41985	1	32.1±0.8 1.264±.031	16.1±0.3 .634±.012	9.15±0.35 .360±.014	9.2±0.3 .362±.012	22.7 .894	11.6±0.3 .457±.012	4.4 .173	
PC40EE35/28B-Z	U.S. EE-375	1	34.6±0.5 1.362±.020	14.27±0.37 .562±.014	9.31±0.30 .367±.012	9.4±0.3 .370±.012	25.0 .984	9.78±0.25 .385±.010	4.5 .177	
PC40EE35-Z	JIS FEE35B	1	34.54±1.0 1.360±.039	14.35±0.35 .564±.014	9.53±0.38 .375±.015	9.39±0.27 .370±.011	24.89 .980	9.71±0.28 .382±.011	4.75 .187	
PC40EE40-Z	JIS FEE40A	1	40.0±0.5 1.575±.020	17.0±0.3 .669±.012	10.7±0.3 .421±.012	10.7±0.3 .421±.012	27.4 1.079	10.25±0.25 .404±.010	6.0 .236	
PC40EE41/33C-Z	U.S. EE-21	1	41.07±0.8 1.617±.031	16.78±0.4 .661±.016	12.57±0.38 .495±.015	12.64±0.45 .498±.018	28.55 1.124	10.38±0.3 .409±.012	6.0 .236	
PC40EE42/42/15-Z	DIN 41295	JIS FEE42A	1	42.15±0.85 1.659±.033	21.0±0.2 .827±.008	14.95±0.25 .589±.010	11.95±0.25 .470±.010	29.5 1.161	15.15±0.35 .596±.014	6.025 .237
PC40EE42/42/20-Z	DIN 41295	JIS FEE42B	1	42.15±0.85 1.659±.033	21.0±0.2 .827±.008	19.7±0.3 .776±.012	11.95±0.25 .470±.010	29.5 1.161	15.15±0.35 .596±.014	6.025 .237

Part No.	Effective parameter				Electrical characteristics			Wt (g)	Bobbin item
	C <sub>1</sub> (mm <sup>-1</sup> )	A <sub>e</sub> (mm <sup>2</sup> )	l <sub>e</sub> (mm)	V <sub>e</sub> (mm <sup>3</sup> )	AL-value (nH/N <sup>2</sup> )*		Core loss (W) max. 100kHz, 200mT, 100°C		
					Without air gap	With air gap			
PC40EF32-Z	0.893	83.2	74.3	6180	2590±25%	160±5% 250±7%	2.90	32	—
PC40EE35/28B-Z	0.819	84.9	69.6	5907	2950±25%	200±5% 400±7%	2.33	28	—
PC40EE35-Z	0.774	89.3	69.2	6179	3170±25%	200±5% 400±7%	3.00	57	—
PC40EE40-Z	0.606	128	77.3	9890	4150±25%	200±5% 400±7%	4.20	50	BE40-1112CPFR BE40-1112CPNFR BE-40-5112
PC40EE41/33C-Z	0.495	157	77.6	12200	5060±25%	200±5% 400±7%	5.80	64	—
PC40EE42/42/15-Z	0.534	182	97.0	17600	4700±25%	250±5% 400±7%	8.00	80	—
PC40EE42/42/20-Z	0.415	235	97.4	22900	6100±25%	250±5% 400±7%	10.4	116	—

\* AL-value: 1kHz, 0.5mA, 100Ts

## EE AND EF CORES

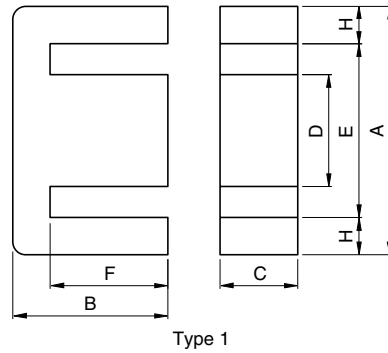
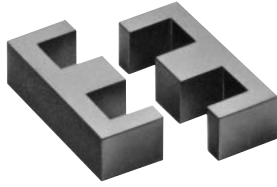

Type 1

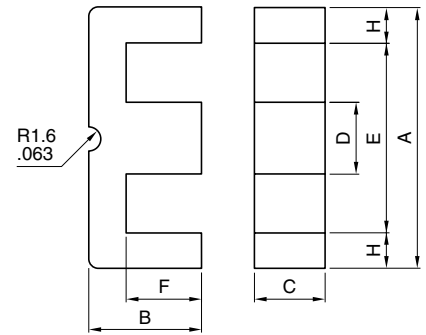

Type 2

Part No.	U.S. lam. cores, DIN standard JIS		Type	Dimensions in $\frac{\text{mm}}{\text{inches}}$						
				A	B	C	D	E min.	F	H
PC40EE47/39-Z	U.S. EE-625		1	47.12±0.48 1.855±0.019	19.63±0.2 .773±.008	15.62±0.25 .615±.010	15.62±0.25 .615±.010	31.72 1.249	12.2±0.13 .480±.005	7.49 .295
PC40EE50-Z	JIS FEE50A		1	50.0 <sup>+1.0</sup> <sub>-0.7</sub> 1.969 <sup>+0.039</sup> <sub>-.028</sub>	21.3±0.3 .839±.012	14.6±0.4 .575±.016	14.6±0.4 .575±.016	34.2 1.346	12.75±0.25 .502±.010	7.5 .295
PC40EE55/55/21-Z	DIN 41295	JIS FEE55	1	55.15±1.05 2.17±.041	27.5±0.3 1.083±.012	20.7±0.3 .815±.012	16.95±0.25 .667±.010	37.5 1.476	18.8±0.3 .740±.012	8.53 .336
PC40EE57/47-Z	U.S. EE-75		1	56.57±1.00 2.227±.039	23.60±0.23 .929±.009	18.8±0.25 .740±.010	18.80±0.25 .740±.010	38.1 1.500	14.63±0.15 .576±.006	9.02 .355
PC40EE60-Z	JIS FEE60A		1	60.0 <sup>+1.1</sup> <sub>-0.8</sub> 2.362 <sup>+0.043</sup> <sub>-.031</sub>	22.3±0.3 .878±.012	15.6±0.4 .614±.016	15.6±0.4 .614±.016	43.8 1.724	14.05±0.25 .553±.010	7.7 .303
PC40EE50.3/51/6-Z			1	50.3±0.8 1.980±.031	25.6±0.25 1.008±.010	6.1 <sup>+0.4</sup> <sub>-0.2</sub> .240 <sup>+0.016</sup> <sub>-.008</sub>	19.9±0.35 .783±.014	29.5 1.161	15.9±0.25 .626±.010	10 .394
PC40EE62.3/62/6-Z			1	62.3±1.2 2.453±.047	31.0±0.25 1.220±.010	6.1 <sup>+0.4</sup> <sub>-0.2</sub> .240 <sup>+0.016</sup> <sub>-.008</sub>	25.3±0.5 .996±.020	35.9 1.413	18.7±0.25 .736±.010	12.6 .496

Part No.	Effective parameter				Electrical characteristics			Wt (g)	Bobbin item
	C <sub>1</sub> (mm <sup>-1</sup> )	A <sub>e</sub> (mm <sup>2</sup> )	l <sub>e</sub> (mm)	V <sub>e</sub> (mm <sup>3</sup> )	AL-value (nH/N <sup>2</sup> )*		Core loss (W) max. 100kHz, 200mT, 100°C		
					Without air gap	With air gap			
PC40EE47/39-Z	0.374	242	90.6	21930	6660±25%	250±5% 400±7%	9.70	108	—
PC40EE50-Z	0.425	226	95.8	21600	6110±25%	250±5% 400±7%	9.40	116	BE50-1112CPFR BE-50-5112
PC40EE55/55/21-Z	0.348	354	123	43700	7100±25%	250±5% 400±7%	11.0**	234	—
PC40EE57/47-Z	0.297	344	102	35100	8530±25%	250±5% 400±7%	8.5**	190	—
PC40EE60-Z	0.446	247	110	27100	5670±25%	250±5% 500±7%	12.5	135	BE60-1112CPFR BE-60-5112
PC40EE50.3/51/6-Z	0.868	121	105	12700	2900±25%	200±5% 400±7%	5.83	68	BE50.3-1112CPHFR
PC40EE62.3/62/6-Z	0.822	153	126	19300	3100±25%	200±5% 400±7%	8.85	102	BE62.3-1112CPHFR

\* AL-value: 1kHz, 0.5mA, 100Ts

\*\* Core loss: 100kHz, 150mT, 100°C

## EE AND EI BOBBINS

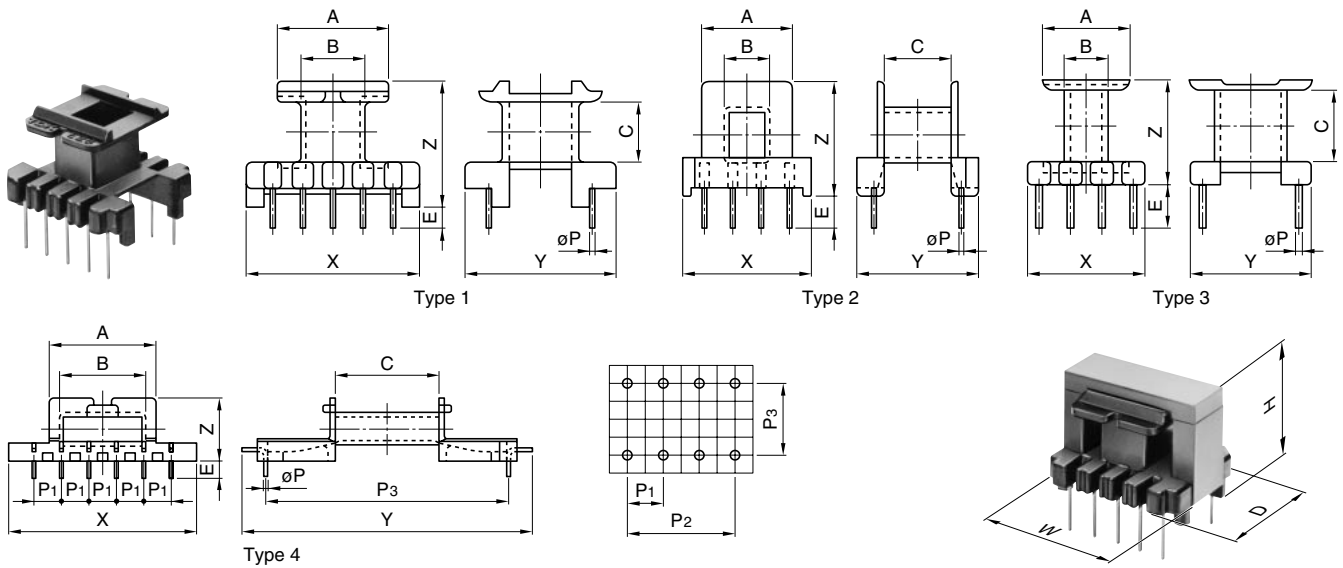

Part No.	Type	Dimensions in							
		mm		inches					
		A	B	C	E	X	Y	Z	t*
BE8-116CPHFR	2	5.75 .226	3.0 .118	4.78 .188	2.70 .106	8.00 .315	8.80 .346	8.40 .331	0.35 .014
BE10-118CPSFR	3	7.2 .283	3.53 .139	6.6 .260	3.85 .152	10.15 .400	10.2 .402	9.0 .354	0.35 .014
BE12.5-1110CPFR	1	8.5 .335	3.58 .141	3.5 .138	3.25 .128	12.35 .486	12.35 .486	8.3 .327	0.325 .013
BE13-1110CPSFR	3	9.95 .392	4.05 .159	7.4 .291	3.7 .146	12.1 .476	12.6 .496	10.4 .409	0.40 .016
BE16-116CPFR	3	11.48 .452	5.15 .203	8.5 .335	3.8 .150	11.48 .452	13.0 .512	11.5 .453	0.375 .015
BE16-118CPHFR	2	11.4 .449	5.15 .203	8.6 .339	4.0 .157	15.0 .591	13.4 .528	13.30 .524	0.325 .013
BE16-1110CPNFR	1	11.35 .447	5.65 .222	8.20 .323	3.8 .150	16.0 .630	13.0 .512	13.90 .547	0.55 .022
BES-16-1110CPSFR	3	12.2 .480	4.55 .179	8.7 .343	5.0 .197	15.9 .426	14.0 .551	11.7 .461	0.45 .018
BE19-116CPFR	3	13.8 .543	5.8 .228	9.1 .358	5.0 .197	13.8 .543	16.5 .650	12.05 .474	0.35 .014
BE19-118CPHFR	2	14.0 .551	6.65 .262	9.0 .354	6.0 .236	20.0 .787	16.2 .638	18.6 .732	0.80 .031

Part No.	Dimensions in mm				Terminal pins	W D (mm)	Parameter		Wt (g)	Accessory item
	øP (mm)	P1 (mm)	P2 (mm)	P3 (mm)			Aw (mm <sup>2</sup> )	øw (mm)		
BE8-116CPHFR	0.6	2.5	5.0	7.0	6	8.3 8.0 8.0	5.3	19.9	0.26	—
BE10-118CPSFR	0.5	(2.6, 2.5)	7.7	8.0	8	10.4 10.2 11.2	12.2	23.8	0.34	—
BE12.5-1110CPFR	0.6	2.5	10.0	7.5	10	12.7 12.5 9.1	8.6	27.2	0.64	—
BE13-1110CPSFR	0.6	2.5	10.0	8.6	10	13.2 12.3	22.2	31.3	0.63	—
BE16-116CPFR	0.6	3.1	6.2	9.2	6	16.3 13.1 14.6	27.3	32.5	0.63	—
BE16-118CPHFR	0.6	3.0	9.0	11.0	8	16.5 14.6 13.6	26.7	33.1	0.84	—
BE16-1110CPNFR	0.6	3.25	13.0	10.5	10	16.3 13.2 15.6	23.2	33.0	1.2	—
BES-16-1110CPSFR	0.6	3.3	13.2	11.0	10	16.3 14.1 16.3	33.1	37.1	1.0	—
BE19-116CPFR	0.5	4.0	8.0	12.5	6	20.3 16.7 16.2	36.4	36.8	0.95	—
BE19-118CPHFR	0.8	5.08	15.24	12.7	8	20.3 18.2 18.8	33.1	39.1	2.4	—

UL Grade: 94V-0, Material: FR phenol, Pin material: Steel wire (Solder plated)

Maximum number of turns N that can be wound on bobbins, see section of "Maximum number of Turns on Bobbins".

\* Minimum thickness of bobbin inside which core is placed, including flanges.

# EE AND EI BOBBINS

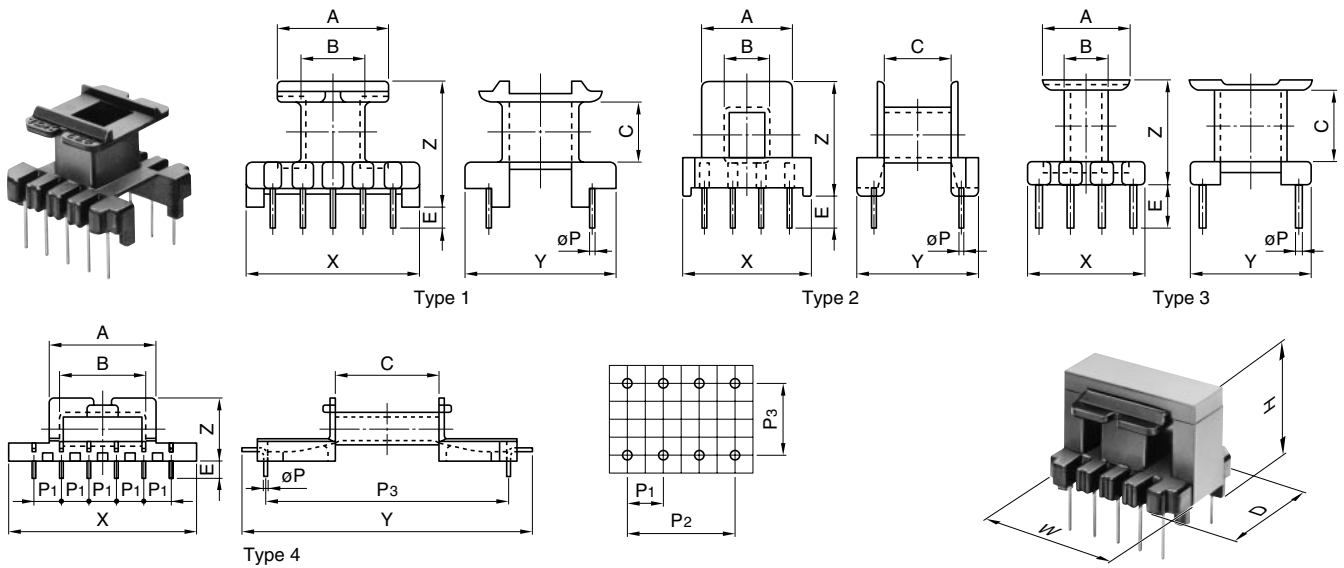

Part No.	Type	Dimensions in							
		mm		inches					
		A	B	C	E	X	Y	Z	t*
BE22-118CPFR	1	12.5 .492	7.9 .311	8.45 .332	6.0 .236	22.0 .866	17.0 .669	17.3 .681	0.85 .033
BE22/19/6-118CPFR	1	15.2 .598	7.9 .311	8.45 .332	6.0 .236	22.0 .866	17.0 .669	17.3 .681	0.85 .033
BE25-118CPFR	1	18.1 .713	9.1 .358	9.8 .386	6.0 .236	25.0 .984	18.0 .709	19.3 .760	0.90 .035
BE28-1110CPLFR	1	18.1 .713	9.9 .390	9.6 .378	7.0 .276	28.0 1.102	25.0 .984	20.6 .811	0.90 .035
BE30-1110CPFR	1	19.2 .756	13.1 .516	13.7 .539	7.0 .276	30.0 1.181	25.0 .984	24.65 .970	0.85 .033
BE30-1112CPFR	1	19.4 .764	13.1 .516	13.7 .539	7.0 .276	30.0 1.181	25.0 .984	24.65 .970	0.70 .028
BE33-1112CPLFR	1	23.1 .909	12.4 .488	16.6 .654	7.0 .276	33.0 1.299	28.0 1.102	28.6 1.126	0.90 .035
BE35-1112CPLFR	1	24.0 .945	12.7 .500	15.7 .618	7.0 .276	35.0 1.378	25.0 .984	28.7 1.130	0.90 .035
BE40-1112CPFR	1	26.5 1.043	14.0 .551	17.3 .681	7.0 .276	36.0 1.417	30.0 1.181	30.5 1.201	0.80 .031
BE40-1112CPNFR	1	26.5 1.043	14.0 .551	17.3 .681	7.0 .276	36.0 1.417	30.0 1.181	30.5 1.201	0.80 .031

Part No.	Dimensions in mm					Terminal pins	W D (mm) H	Parameter		Wt (g)	Accessory item
	øP (mm)	P1 (mm)	P2 (mm)	P3 (mm)	Aw (mm <sup>2</sup> )			ø w (mm)			
BE22-118CPFR	0.8	5.0	15.0	12.5	8	22.3 17.1 20.1	20.0	38.6	2.3	—	
BE22/19/6-118CPFR	0.8	5.0	15.0	12.5	8	22.4 17.1 19.1	31.5	42.8	2.7	—	
BE25-118CPFR	0.8	5.0	15.0	12.5	8	25.8 18.1 20.5	42.5	49.4	3.5	—	
BE28-1110CPLFR	0.8	5.0	20.0	17.5	10	28.5 25.1 22.7	39.4	59.1	5.0	—	
BE30-1110CPFR	0.8	5.0	20.0	20.0	10	30.4 25.1 28.6	44.5	61.0	4.9	FE-30-F FE-30-G	
BE30-1112CPFR	0.8	5.0	25.0	20.0	12	30.4 25.1 28.6	43.2	58.0	6.2	—	
BE33-1112CPLFR	0.8	5.0	25.0	22.5	12	33.5 28.1 31.2	88.8	72.3	6.8	—	
BE35-1112CPLFR	0.8	5.0	25.0	20.0	12	35.5 30.9 30.9	88.7	68.5	7.7	—	
BE40-1112CPFR	1.0	5.0	25.0	25.0	12	40.5 35.8 35.8	108.0	76.0	9.7	—	
BE40-1112CPNFR	1.0	5.0	25.0	22.5	12	40.5 30.2 35.7	108.1	75.6	9.8	FE-40-F FE-40-G	

UL Grade: 94V-0, Material: FR phenol, Pin material: Steel wire (Solder plated)  
 Maximum number of turns N that can be wound on bobbins, see section of "Maximum number of Turns on Bobbins".  
 \* Minimum thickness of bobbin inside which core is placed, including flanges.

• All specifications are subject to change without notice.

## EE AND EI BOBBINS

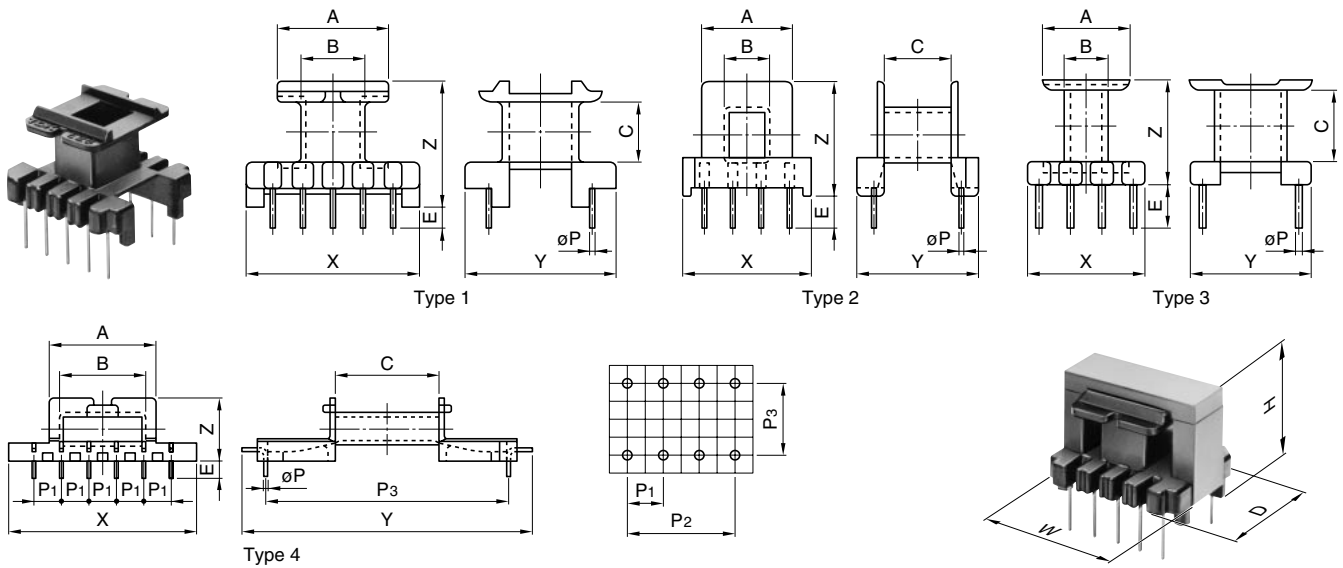

Part No.	Type	Dimensions in							
		mm		inches					
		A	B	C	E	X	Y	Z	t*
BE50-1112CPFR	1	33.2 1.307	17.2 .677	21.3 .839	9.0 .354	50.0 1.969	36.0 1.417	36.65 1.443	0.85 .033
BE60-1112CPFR	1	43.3 1.705	18.60 .732	23.8 .937	10.0 .394	56.0 2.205	45.0 1.772	38.9 1.531	0.95 .037
BE50.3-1112CPHFR	4	29.1 1.146	22.3 .878	28.25 1.112	4.5 .177	51.0 2.008	74.79 2.944	16.10 .634	0.75 .030
BE62.3-1112CPHFR	4	35.1 1.382	28.3 1.114	33.85 1.333	4.5 .177	63.20 2.488	85.6 3.370	16.10 .634	0.75 .030

Part No.	Dimensions in mm					Terminal pins	W D (mm) H	Parameter		Wt (g)	Accessory item
	ØP (mm)	P1 (mm)	P2 (mm)	P3 (mm)	Aw (mm <sup>2</sup> )			ℓ w (mm)			
BE50-1112CPFR	1.0	7.5	37.5	27.5	12	50.7 36.2 43.6	170.0	94.0	17	FE-50-F FE-50-G	
BE60-1112CPFR	1.0	7.5	37.5	35.0	12	50.8 45.2 45.1	294.0	113.0	29	FE-60-F FE-60-G	
BE50.3-1112CPHFR	0.9	7.5	37.5	60	12	52 77 16.2	96.05	76	16	—	
BE62.3-1112CPHFR	0.9	7.5	37.5	72.5	12	64 88 16.2	115.09	88	22	—	

UL Grade: 94V-0, Material: FR phenol, Pin material: Steel wire (Solder plated)

Maximum number of turns N that can be wound on bobbins, see section of "Maximum number of Turns on Bobbins".

\* Minimum thickness of bobbin inside which core is placed, including flanges.

## EE AND EI BOBBINS

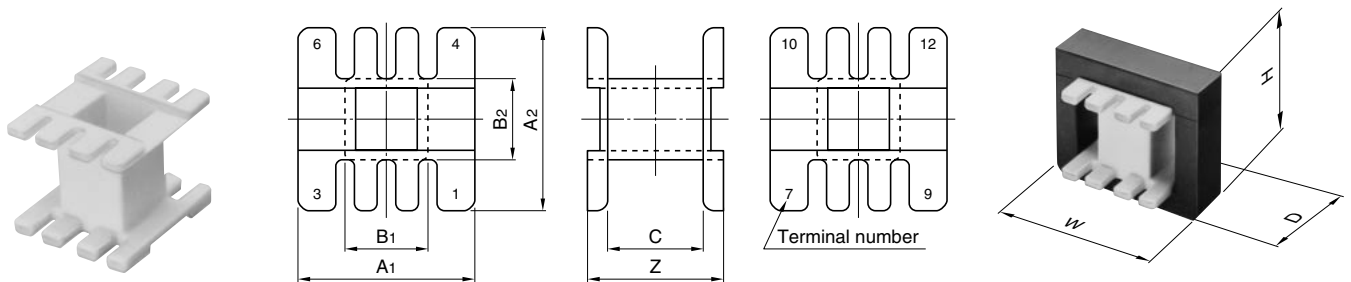

Part No.	Dimensions in							
	mm		inches					
	A1	A2	B1	B2	C	Z	t*	W D (mm) H
<b>BE-19-5116</b>	13.7 .539	14.8 .583	6.4 .252	7.15 .281	9.33 .367	11.93 .470	0.60 .024	20.3 14.9 16.2
<b>BE-22-5116</b>	12.53 .493	13.0 .512	7.7 .303	8.0 .315	8.68 .342	11.28 .444	0.575 .023	22.3 13.1 19.5
<b>BE-25-5116</b>	18.1 .713	19.1 .752	8.7 .343	9.2 .362	10.13 .399	14.6 .575	0.725 .029	25.8 19.2 18.7
<b>BE-30-5112</b>	18.85 .742	20.8 .819	13.0 .512	13.0 .512	13.95 .549	18.5 .728	0.60 .024	30.4 21.1 27.2
<b>BE-40-5112</b>	26.35 1.037	29.1 1.146	14.4 .567	15.4 .606	17.6 .693	23.55 .927	0.80 .031	40.5 29.4 35.3
<b>BE-50-5112</b>	32.75 1.289	35.55 1.400	17.4 .685	18.4 .724	22.1 .870	30.1 1.185	0.80 .031	50.7 35.8 43.0
<b>BE-60-5112</b>	42.75 1.683	45.75 1.801	19.5 .768	20.5 .807	24.1 .949	34.1 1.343	1.30 .051	60.8 46.0 45.0

Part No.	Parameter				Material	Accessory item
	Aw (mm <sup>2</sup> )	∅ w (mm)	Wt (g)			
<b>BE-19-5116</b>	35.7	37.9	0.55		6-Nylon	
<b>BE-22-5116</b>	21.7	38.2	0.45		6-Nylon	
<b>BE-25-5116</b>	47.6	50.6	1.3		6-Nylon	
<b>BE-30-5112</b>	47.6	66.0	1.5		6-Nylon	FE-30-F FE-30-G
<b>BE-40-5112</b>	110.0	85.0	3.8		6-Nylon	FE-40-F FE-40-G
<b>BE-50-5112</b>	178.0	100.0	6.6		6-Nylon	FE-50-F FE-50-G
<b>BE-60-5112</b>	289.0	128.0	15		6-Nylon	FE-60-F FE-60-G

UL Grade: 94V-0

Maximum number of turns N that can be wound on bobbins, see section of "Maximum number of Turns on Bobbins".

\* Minimum thickness of bobbin inside which core is placed, including flanges.

# EER CORES

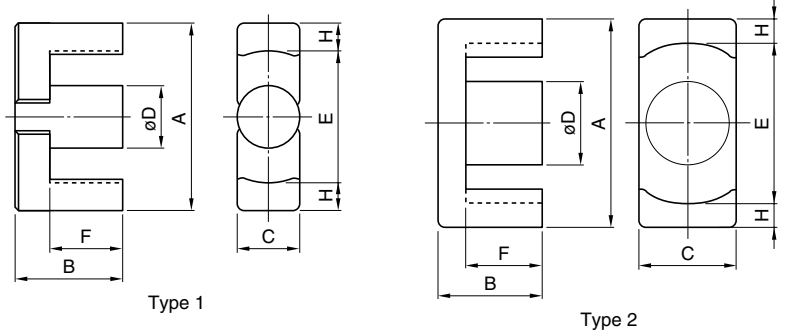
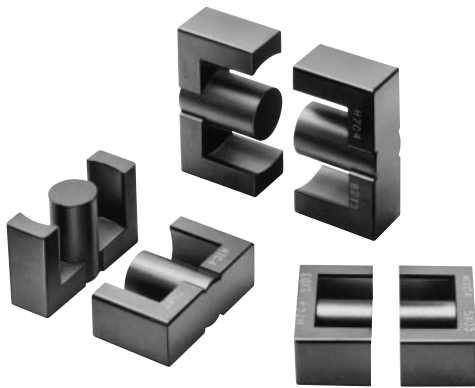

Part No.	U.S. lam. cores, DIN standard JIS	Type	Dimensions in $\frac{\text{mm}}{\text{inches}}$						
			A	B	C	D	E min.	F	H
PC40EER25.5-Z	JIS FEER25.5A	1	25.5±0.5	9.3±0.2	7.5±0.2	7.5±0.15	19.8	6.2±0.2	2.6
			1.004±.020	.366±.008	.295±.008	.295±.006	.779	.244±.008	.102
PC40EER28-Z	JIS FEER28.5A	2	28.55±0.55	14.0±0.2	11.4±0.25	9.9±0.25	21.2	9.65±0.25	3.4
			1.124±.022	.551±.008	.499±.010	.390±.010	.835	.380±.010	.134
PC40EER28L-Z	JIS FEER28.5B	2	28.55±0.55	16.9±0.25	11.4±0.25	9.9±0.25	21.2	12.53±0.28	3.4
			1.124±.022	.665±.010	.499±.010	.390±.010	.835	.493±.011	.134
PC40EER35-Z	JIS FEER35A	1	35.0±0.5	20.7±0.2	11.3±0.2	11.3±0.15	25.6	14.7±0.3	4.43
			1.378±.020	.815±.008	.445±.008	.445±.006	1.009	.579±.012	.174
PC40EER40-Z		1	40.0±0.5	22.4±0.2	13.3±0.25	13.3±0.25	29.0	15.4±0.3	5.28
			1.575±.020	.882±.008	.524±.010	.524±.010	1.142	.606±.012	.208
PC40EER42-Z	JIS FEER42	1	42.0±0.6	22.4±0.2	15.5±0.25	15.5±0.25	29.4	15.4±0.3	6.0
			1.654±.024	.882±.008	.610±.010	.610±.010	1.157	.606±.012	.236
PC40EER42/42/20-Z		2	42.15±0.65	21.2±0.2	19.60±0.4	17.3±0.25	31.8	15.25±0.25	4.93
			1.659±.026	.835±.008	.772±.016	.681±.010	1.252	.600±.010	.194
PC40EER49-Z		1	49.0±0.8	19.0±0.3	17.2±0.4	17.2±0.25	36.4	12.4±0.2	6.0
			1.929±.031	.748±.012	.677±.016	.677±.010	1.433	.488±.008	.236

Part No.	Effective parameter				Electrical characteristics			Wt (g)	Bobbin item
	C <sub>1</sub> (mm <sup>-1</sup> )	A <sub>e</sub> (mm <sup>2</sup> )	l <sub>e</sub> (mm)	V <sub>e</sub> (mm <sup>3</sup> )	AL-value (nH/N <sup>2</sup> )*		Core loss (W) max. 100kHz, 200mT, 100°C		
					Without air gap	With air gap			
PC40EER25.5-Z	1.08	44.8	48.2	2160	1920±25%	100±5% 200±7%	0.98	11	BEER25.5-118CPFR
PC40EER28-Z	0.780	82.1	64.0	5250	2870±25%	200±5%	2.30	28	BEER28-1110CPFR
						400±7%			BEER28-1112CPHFR
PC40EER28L-Z	0.928	81.4	75.5	6150	2520±25%	160±5%	2.70	33	BEER28L-1110CPFR
						315±7%			BEER28L-1112CPHFR
PC40EER35-Z	0.849	107	90.8	9720	2770±25%	200±5%	4.20	52	BEER35-1112CPFR
						400±7%			BEER35-1116CPHFR
PC40EER40-Z	0.658	149	98.0	14600	3620±25%	200±5%	6.30	78	BEER40-1112CPFR
						400±7%			BEER40-1116CPHFR
PC40EER42-Z	0.509	194	98.8	19200	4690±25%	250±5%	8.60	102	BEER42-1114CPFR
						500±7%			BEER42-1116CPHFR
PC40EER42/42/20-Z	0.411	240	98.6	23700	5340±25%	250±5%	10.7	116	BEER42/20-1112CPFR
						500±7%			
PC40EER49-Z	0.395	231	91.3	21100	6250±25%	250±5%	5.4**	110	BEER49-1118CPFR
						500±7%			

\* AL-value: 1kHz, 0.5mA, 100Ts

\*\* Core loss: 100kHz, 150mT, 100°C

## EER BOBBINS

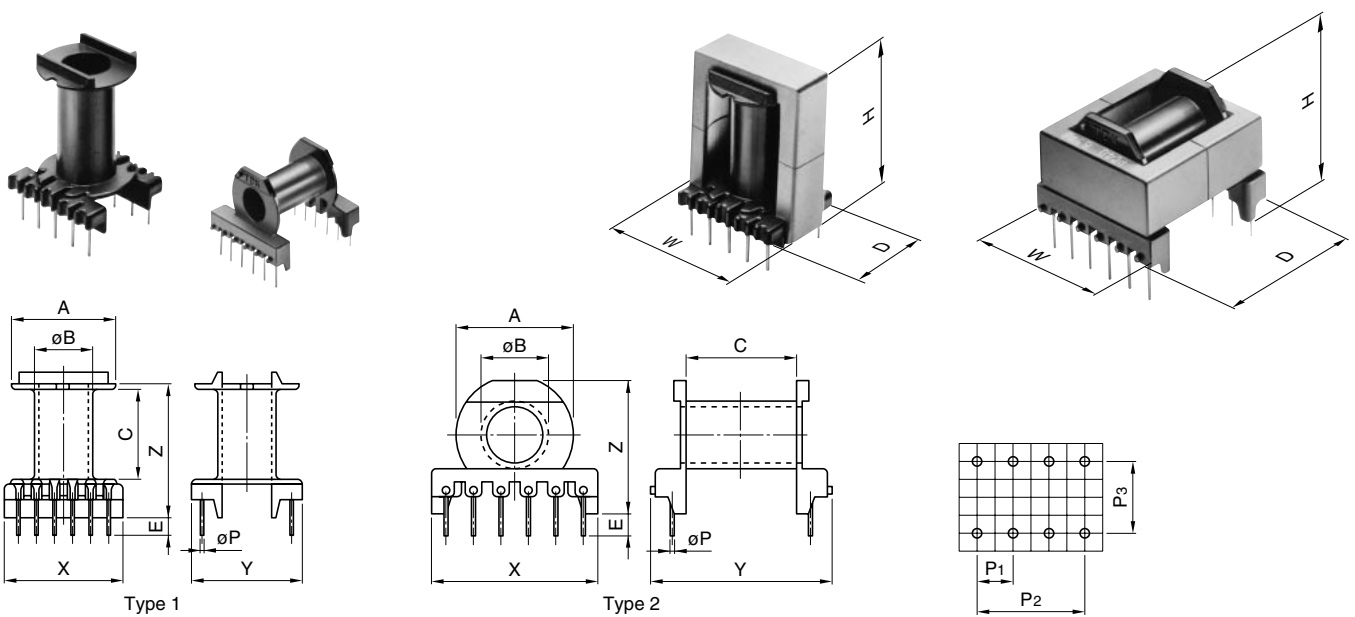

Part No.	Type	Dimensions in mm inches							
		A	øB	C	E	X	Y	Z	t*
BEER25.5-118CPFR	1	19.53 .769	9.9 .390	10.05 .396	4.5 .177	22.0 .866	19.6 .772	16.95 .667	0.95 .037
BEER28-1110CPFR	1	20.9 .823	12.3 .484	16.7 .657	4.5 .177	24.8 .976	23.0 .906	24.00 .945	0.95 .037
BEER28L-1110CPFR	1	20.9 .823	12.3 .484	22.4 .882	4.5 .177	24.8 .976	23.0 .906	29.70 1.169	0.95 .037
BEER35-1112CPFR	1	25.4 1.000	13.7 .539	26.1 1.028	5.5 .217	30.0 1.181	28.5 1.122	37.50 1.476	0.98 .039
BEER40-1112CPFR	1	28.7 1.130	15.8 .622	27.5 1.083	5.0 .197	32.0 1.260	30.0 1.181	38.90 1.531	0.98 .039
BEER42-1114CPFR	1	29.1 1.146	17.95 .707	27.5 1.083	5.0 .197	38.0 1.496	30.0 1.181	39.90 1.571	0.95 .037
BEER42/20-1112CPFR	1	31.5 1.240	19.85 .781	27.3 1.075	5.0 .197	43.5 1.713	37.0 1.457	39.70 1.563	0.95 .037

Part No.	Dimensions in mm					Terminal pins	Parameter		Wt (g)
	øP (mm)	P1 (mm)	P2 (mm)	P3 (mm)	W D (mm) H		Aw (mm <sup>2</sup> )	ℓ w (mm)	
BEER25.5-118CPFR	0.8	5.0	15	12.5	8	26 20 21	48.4	46.2	2.7
BEER28-1110CPFR	0.8	5.0	20	17.5	10	29 23 29	71.8	52.2	3.5
BEER28L-1110CPFR	0.8	5.0	20	17.5	10	29 23 35	96.3	52.2	3.9
BEER35-1112CPFR	1.0	5.0	25	22.5	12	36 29 44	152.7	61.4	7.7
BEER40-1112CPFR	1.0	5.0	25	25	12	41 30 46	178.8	69.9	8.9
BEER42-1114CPFR	1.0	5.0	30	25	14	43 30 47	153.3	73.9	9.8
BEER42/20-1112CPFR	1.0	7.5	37.5	30	12	43 37 46	159.7	80.6	12

UL Grade: 94V-0, Material: FR phenol, Pin material: Steel wire (Solder plated)

Maximum number of turns N that can be wound on bobbins, see section of "Maximum number of Turns on Bobbins".

\* Minimum thickness of bobbin inside which core is placed, including flanges.



# EER BOBBINS

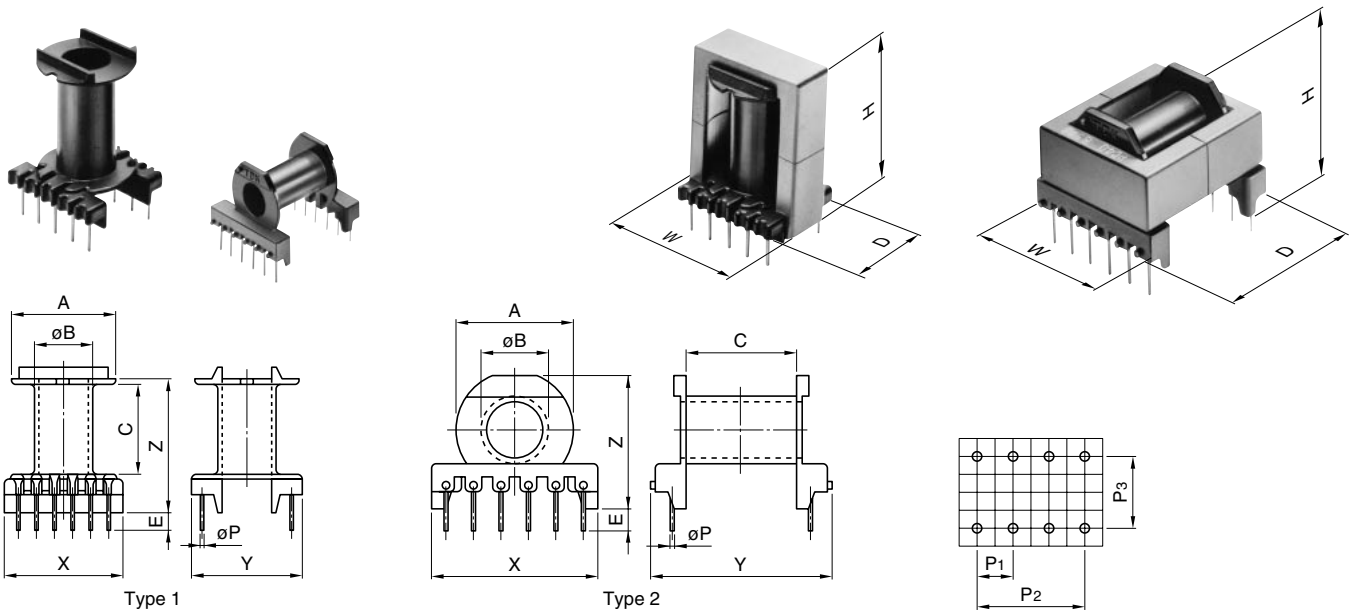

Part No.	Type	Dimensions in mm inches							
		A	øB	C	E	X	Y	Z	t*
BEER49-1118CPFR	1	35.95 1.415	20.3 .799	21.45 .844	4.5 .177	49.0 1.929	37.0 1.457	34.95 1.376	1.05 .041
BEER28-1112CPHFR	2	20.9 .823	12.0 .472	16.1 .634	5.0 .197	30.0 1.181	31.3 1.232	25.0 .984	0.83 .033
BEER28L-1112CPHFR	2	20.9 .823	12.0 .472	21.8 .858	5.0 .197	30.0 1.181	37.0 1.457	25.0 .984	0.83 .033
BEER35-1116CPHFR	2	25.2 .992	13.6 .535	26.4 1.039	4.5 .177	40.0 1.575	45.5 1.791	28.95 1.140	0.93 .037
BEER40-1116CPHFR	2	28.6 1.126	15.7 .618	27.5 1.083	4.2 .165	40.0 1.575	44.0 1.732	31.75 1.250	0.93 .037
BEER42-1116CPHFR	2	29.0 1.142	17.90 .705	27.3 1.075	5.0 .197	40.15 1.581	44.25 1.742	34.5 1.358	0.93 .037

Part No.	Dimensions in mm					Parameter			Wt (g)
	øP (mm)	P1 (mm)	P2 (mm)	P3 (mm)	Terminal pins	W D (mm) H	Aw (mm <sup>2</sup> )	ℓ w (mm)	
BEER49-1118CPFR	0.8	5.0	40	30	18	50 37 43	167.8	88.4	15
BEER28-1112CPHFR	0.8	5.0	25	25	12	31 32 26	71.6	51.6	5.2
BEER28L-1112CPHFR	0.8	5.0	25	30	12	31 38 26	97.0	51.7	5.5
BEER35-1116CPHFR	□0.75	5.0	35	35	16	41 46 31	154.4	60.8	11
BEER40-1116CPHFR	1.0	5.0	35	35	16	41 45 32	170.6	69.9	11
BEER42-1116CPHFR	1.0	5.0	35	35	16	43 46 35	148.5	73.8	12

UL Grade: 94V-0, Material: FR phenol, Pin material: Steel wire (Solder plated)  
 Maximum number of turns N that can be wound on bobbins, see section of "Maximum number of Turns on Bobbins".  
 \* Minimum thickness of bobbin inside which core is placed, including flanges.

• All specifications are subject to change without notice.

## ETD CORES

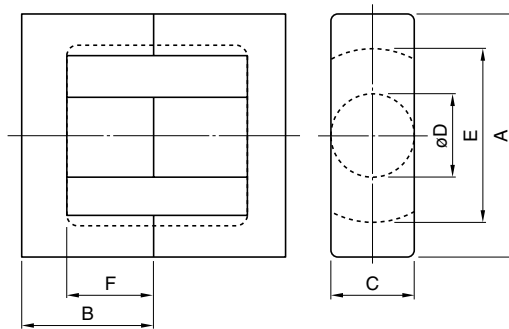
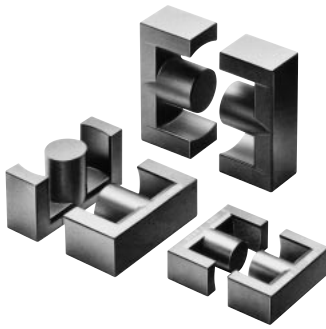

Part No.	JIS	Dimensions in					
		mm		inches			
		A	B	C	øD	E	F
PC40ETD19-Z		19.6±0.5	13.65±0.15	7.4±0.2	7.4±0.2	14.9±0.5	9.4±0.2
		.771±.020	.537±.006	.291±.008	.291±.008	.586±.020	.370±.008
PC40ETD24-Z		24.4±0.6	14.45±0.15	8.5±0.4	8.5±0.2	18.6±0.6	10.1±0.2
		.960±.024	.569±.006	.335±.016	.335±.008	.732±.024	.398±.008
PC40ETD29-Z		29.8±0.8	15.80±0.15	9.5±0.3	9.5±0.3	22.7±0.7	11.0±0.3
		1.173±.031	.622±.006	.374±.012	.374±.012	.893±.028	.433±.012
PC40ETD34-Z	JIS	34.2±0.8	17.3±0.2	10.88±0.38	10.8±0.3	26.3±0.7	12.1±0.3
	FEER 34.2	1.346±.031	.681±.008	.428±.015	.425±.012	1.035±.028	.476±.012
PC40ETD39-Z	JIS	39.1±0.9	19.8±0.2	12.58±0.38	12.5±0.3	30.1±0.8	14.6±0.4
	FEER 39.1	1.539±.035	.780±.008	.495±.015	.492±.012	1.185±.031	.575±.016
PC40ETD44-Z	JIS	44.0±1.0	22.3±0.2	14.9±0.5	14.8±0.4	33.3±0.8	16.5±0.4
	FEER 44	1.732±.039	.878±.008	.587±.020	.583±.016	1.311±.031	.650±.016
PC40ETD49-Z	JIS	48.7±1.1	24.7±0.2	16.4±0.5	16.3±0.4	37.0±0.9	18.1±0.4
	FEER 48.7	1.917±.043	.972±.008	.646±.020	.642±.016	1.457±.035	.713±.016

Part No.	Effective parameter				Electrical characteristics		Core loss (W) max. 100kHz, 200mT, 100°C	Wt (g)	Bobbin item
	C <sub>1</sub> (mm <sup>-1</sup> )	A <sub>e</sub> (mm <sup>2</sup> )	l <sub>e</sub> (mm)	V <sub>e</sub> (mm <sup>3</sup> )	AL-value (nH/N <sup>2</sup> )*				
					Without air gap	With air gap			
PC40ETD19-Z	1.32	41.3	54.6	2260	1720±25%	80±5% 160±7%	1.1	14	BETD19-1111CPHFR
PC40ETD24-Z	1.100	56.3	61.9	3480	2125±25%	100±5% 200±7%	1.6	20	BETD24-1112CPHFR
PC40ETD29-Z	0.959	73.6	70.6	5200	2500±25%	200±5% 400±10%	2.4	28	—
PC40ETD34-Z	0.810	97.1	78.6	7630	2780±25%	200±5% 400±7%	3.31	40	—
PC40ETD39-Z	0.737	125	92.1	11500	3150±25%	200±5% 400±7%	5.3	60	—
PC40ETD44-Z	0.589	175	103	18000	4000±25%	250±5% 400±7%	8.3	94	—
PC40ETD49-Z	0.535	213	114	24300	4440±25%	250±5% 400±7%	11.2	124	—

\* AL-value: 1kHz, 0.5mA, 100Ts

## ETD BOBBINS

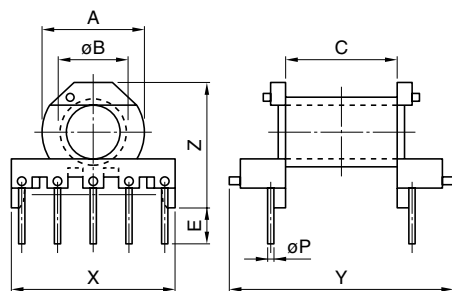
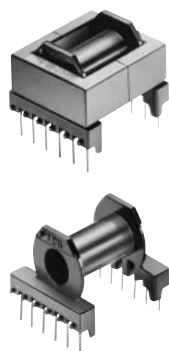

### Bobbin-core assembly dimensions

#### ETD cores

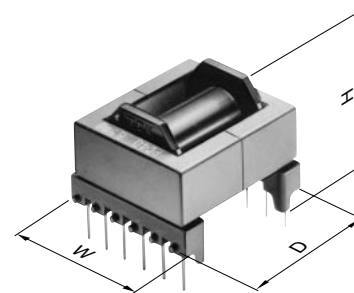

Part No.	Dimensions in		C	E	X	Y	Z	t*
	mm	inches						
BETD19-1111CPHFR	14.0	9.7	16.0	5.0	23.4	31.0	18.15	0.80
	.551	.382	.630	.197	.921	1.220	.715	.031
BETD24-1112CPHFR	17.5	10.9	17.2	5.0	29.0	33.6	21.65	0.80
	.689	.429	.677	.197	1.142	1.223	.852	.031

Part No.	Dimensions in mm					Terminal pins	Parameter	Wt (g)	
	$\phi P$ (mm)	P1 (mm)	P2 (mm)	P3 (mm)	W D (mm) H				
BETD19-1111CPHFR	0.8	5.08	20.32	20.32	10	23.55	37.3	33.2	3.3
						31.0			
						18.15			
BETD24-1112CPHFR	0.8	5.08	25.4	22.86	12	29.0	44.7	55.5	4.8
						33.6			
						21.65			

UL Grade: 94V-0, Material: FR phenol, Pin material: Steel wire (Solder plated)

Maximum number of turns N that can be wound on bobbins, see section of "Maximum number of Turns on Bobbins".

\* Minimum thickness of bobbin inside which core is placed, including flanges.

# PLANAR CORES

## Cores

EL11X4 to EL25X8.6

ELT11X3 to ELT25X8.6

PQI16/7.8 to PQI26/11.5

EIR14/4.5/9 to EIR22/5.5/15

ER14/4.5/9 to ER25/5.5/18

EI14/5/5 to EI22/8/16

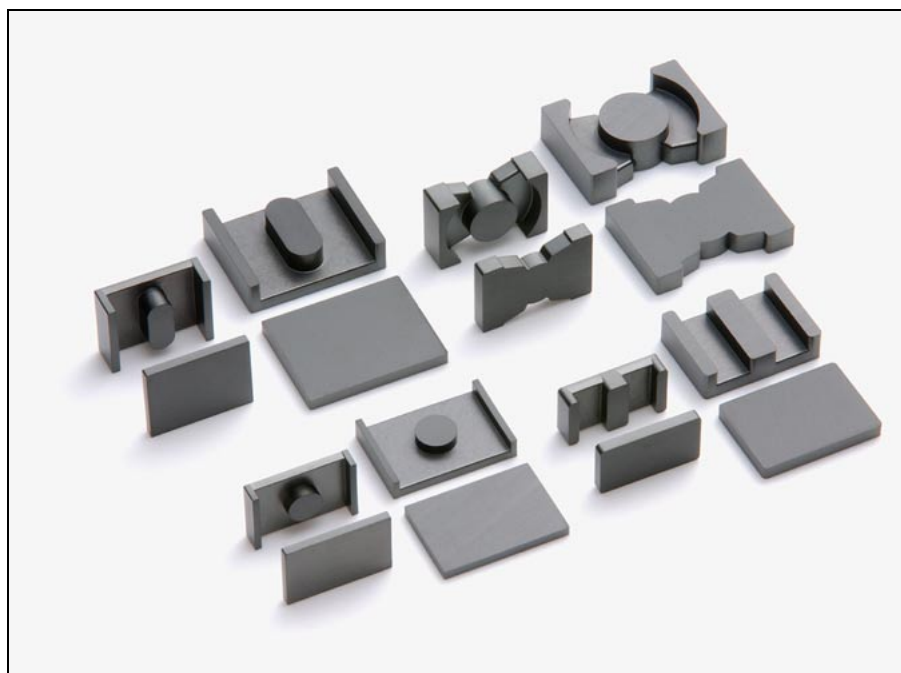

## Ordering Code System

### Cores

PC44 EL 11X4 - Z

Material

Size of EL core

AL-value Z: without air gap

G□: with air gap

## EL CORES

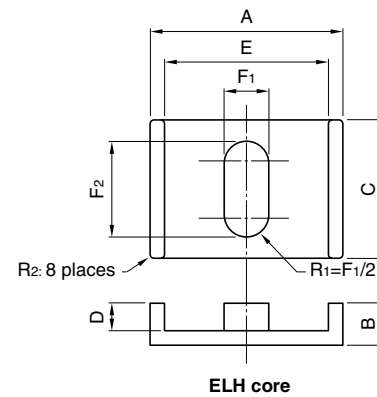
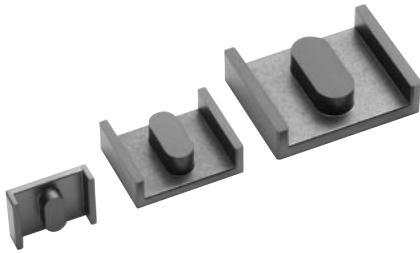

Part No. (ELH+ELH)	Dimensions in		C	D	E	F1	F2	R2
	A	B						
PC44EL11X4-Z								
PC47EL11X4-Z	11.00±0.20	2.01±0.10	8.80±0.20	1.00±0.10	9.17±0.20	2.78±0.10	6.40±0.15	0.30
PC95EL11X4-Z	.433±.008	.079±.004	.346±.008	.039±.004	.361±.008	.109±.004	.252±.006	.012
PC50EL11X4-Z								
PC33EL11X4-Z								
PC44EL13X4.4-Z								
PC47EL13X4.4-Z	13.00±0.25	2.19±0.10	10.40±0.20	1.00±0.10	10.83±0.20	3.29±0.10	7.56±0.15	0.30
PC95EL13X4.4-Z	.512±.010	.086±.004	.409±.008	.039±.004	.426±.008	.130±.004	.298±.006	.012
PC50EL13X4.4-Z								
PC33EL13X4.4-Z								
PC44EL15.5X5.8-Z								
PC47EL15.5X5.8-Z	15.50±0.30	2.92±0.10	12.40±0.25	1.50±0.10	12.92±0.25	3.92±0.10	9.01±0.20	0.30
PC95EL15.5X5.8-Z	.610±.012	.115±.004	.488±.010	.059±.004	.509±.010	.154±.004	.355±.008	.012
PC50EL15.5X5.8-Z								
PC33EL15.5X5.8-Z								
PC44EL18X7.3-Z								
PC47EL18X7.3-Z	18.00±0.30	3.65±0.10	14.40±0.25	2.00±0.10	15.00±0.30	4.55±0.10	10.47±0.20	0.30
PC95EL18X7.3-Z	.709±.012	.144±.004	.567±.010	.079±.004	.591±.012	.179±.004	.412±.008	.012
PC50EL18X7.3-Z								
PC33EL18X7.3-Z								

Part No. (ELH+ELH)	Effective parameter							Electrical characteristics	
	C <sub>1</sub>	ℓ <sub>e</sub>	A <sub>e</sub>	V <sub>e</sub>	A <sub>min.</sub>	A <sub>cw</sub>	W <sub>t</sub>	AL-value (nH/N <sup>2</sup> ) <sup>*</sup>	
	(mm <sup>-1</sup> )	(mm)	(mm <sup>2</sup> )	(mm <sup>3</sup> )	(mm <sup>2</sup> )	(mm <sup>2</sup> )	(g)	Without air gap	With air gap
PC44EL11X4-Z								2040±25%	
PC47EL11X4-Z								2040±25%	50±3%
PC95EL11X4-Z	0.826	13.7	16.5	226	15.9	6.39	1.3	2400±25%	80±5%
PC50EL11X4-Z								1470±25%	125±7%
PC33EL11X4-Z								1470±25%	530±15%**
PC44EL13X4.4-Z								2670±25%	
PC47EL13X4.4-Z								2670±25%	63±3%
PC95EL13X4.4-Z	0.667	15.4	23.1	357	22.4	7.54	2.0	3160±25%	100±5%
PC50EL13X4.4-Z								1890±25%	160±7%
PC33EL13X4.4-Z								1890±25%	720±15%**
PC44EL15.5X5.8-Z								3080±25%	
PC47EL15.5X5.8-Z								3080±25%	63±3%
PC95EL15.5X5.8-Z	0.597	19.6	32.9	646	31.9	13.5	3.5	3680±25%	100±3%
PC50EL15.5X5.8-Z								2250±25%	160±5%
PC33EL15.5X5.8-Z								2250±25%	990±15%**
PC44EL18X7.3-Z								3800±25%	
PC47EL18X7.3-Z								3800±25%	80±3%
PC95EL18X7.3-Z	0.538	23.8	44.3	1050	43.0	20.9	6.0	4760±25%	125±3%
PC50EL18X7.3-Z								2400±25%	200±5%
PC33EL18X7.3-Z								2400±25%	1280±15%**

\* AL-value: 1kHz, 0.5mA, 100Ts

\*\* Only PC95 material

## EL CORES

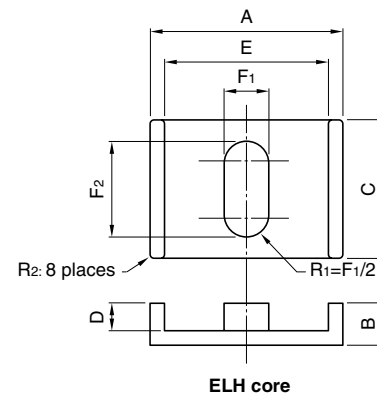
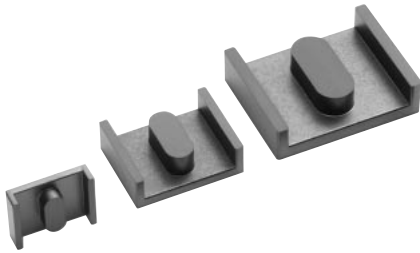

Part No. (ELH+ELH)	Dimensions in		C	D	E	F1	F2	R2
	mm	inches						
PC44EL20X7.7-Z								
PC47EL20X7.7-Z	20.00±0.35	3.83±0.10	16.00±0.30	2.00±0.10	16.67±0.30	5.06±0.15	11.63±0.20	0.50
PC95EL20X7.7-Z	.787±.014	.151±.004	.630±.012	.079±.004	.656±.012	.199±.006	.458±.008	.020
PC50EL20X7.7-Z								
PC33EL20X7.7-Z								
PC44EL22X8-Z								
PC47EL22X8-Z	22.00±0.40	4.02±0.10	17.60±0.30	2.00±0.10	18.33±0.35	5.56±0.15	12.79±0.25	0.50
PC95EL22X8-Z	.866±.016	.158±.004	.693±.012	.079±.004	.722±.014	.219±.006	.504±.010	.020
PC50EL22X8-Z								
PC33EL22X8-Z								
PC44EL25X8.6-Z								
PC47EL25X8.6-Z	25.00±0.45	4.29±0.10	20.00±0.35	2.00±0.10	20.83±0.35	6.32±0.15	14.54±0.25	0.50
PC95EL25X8.6-Z	.984±.018	.169±.004	.787±.014	.079±.004	.820±.014	.249±.006	.572±.010	.020
PC50EL25X8.6-Z								
PC33EL25X8.6-Z								

Part No. (ELH+ELH)	Effective parameter							Electrical characteristics	
	C <sub>1</sub>	ℓ <sub>e</sub>	A <sub>e</sub>	V <sub>e</sub>	A <sub>min.</sub>	A <sub>cw</sub>	Wt	AL-value (nH/N <sup>2</sup> )*	
	(mm <sup>-1</sup> )	(mm)	(mm <sup>2</sup> )	(mm <sup>3</sup> )	(mm <sup>2</sup> )	(mm <sup>2</sup> )	(g)	Without air gap	With air gap
PC44EL20X7.7-Z								4340±25%	
PC47EL20X7.7-Z								4340±25%	80±3%
PC95EL20X7.7-Z	0.469	25.6	54.6	1400	52.9	23.2	7.8	5630±25%	125±3%
PC50EL20X7.7-Z								2800±25%	200±5%
PC33EL20X7.7-Z								2800±25%	1560±15%**
PC44EL22X8-Z								5280±25%	
PC47EL22X8-Z								5280±25%	100±3%
PC95EL22X8-Z	0.413	27.3	66.2	1810	64.2	25.5	10	6540±25%	160±3%
PC50EL22X8-Z								3240±25%	250±5%
PC33EL22X8-Z								3240±25%	1850±15%**
PC44EL25X8.6-Z								6110±25%	
PC47EL25X8.6-Z								6110±25%	100±3%
PC95EL25X8.6-Z	0.350	30.0	85.6	2570	83.0	29.0	15	7540±25%	160±3%
PC50EL25X8.6-Z								4090±25%	250±5%
PC33EL25X8.6-Z								4090±25%	2350±15%**

\* AL-value: 1kHz, 0.5mA, 100Ts

\*\* Only PC95 material

# ELT CORES

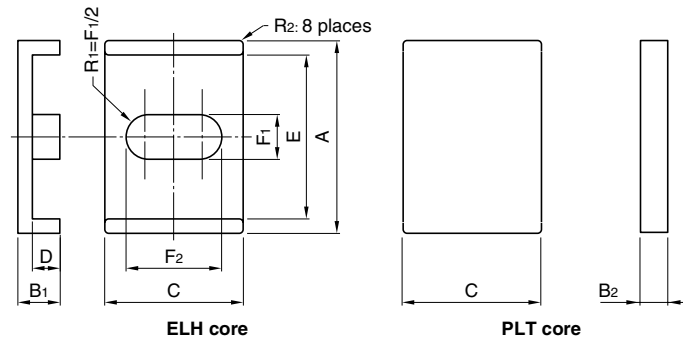
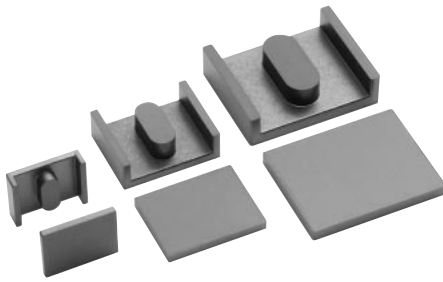

Part No. (ELH+PLT)	Dimensions in								
	A	B <sub>1</sub>	B <sub>2</sub>	C	D	E	F <sub>1</sub>	F <sub>2</sub>	R <sub>2</sub>
PC44ELT11X3-Z									
PC47ELT11X3-Z	11.00±0.20	2.01±0.10	1.01±0.05	8.80±0.20	1.00±0.10	9.17±0.20	2.78±0.10	6.40±0.15	0.30
PC95ELT11X3-Z	.433±.008	.079±.004	.040±.002	.346±.008	.039±.004	.361±.008	.109±.004	.252±.006	.012
PC50ELT11X3-Z									
PC33ELT11X3-Z									
PC44ELT11X4-Z									
PC47ELT11X4-Z	11.00±0.20	3.01±0.10	1.01±0.05	8.80±0.20	2.00±0.10	9.17±0.20	2.78±0.10	6.40±0.15	0.30
PC95ELT11X4-Z	.433±.008	.119±.004	.040±.002	.346±.008	.079±.004	.361±.008	.109±.004	.252±.006	.012
PC50ELT11X4-Z									
PC33ELT11X4-Z									
PC44ELT13X3.4-Z									
PC47ELT13X3.4-Z	13.00±0.25	2.19±0.10	1.19±0.05	10.40±0.20	1.00±0.10	10.83±0.20	3.29±0.10	7.56±0.15	0.30
PC95ELT13X3.4-Z	.512±.010	.086±.004	.047±.002	.409±.008	.039±.004	.426±.008	.130±.004	.298±.006	.012
PC50ELT13X3.4-Z									
PC33ELT13X3.4-Z									
PC44ELT13X4.4-Z									
PC47ELT13X4.4-Z	13.00±0.25	3.19±0.10	1.19±0.05	10.40±0.20	2.00±0.10	10.83±0.20	3.29±0.10	7.56±0.15	0.30
PC95ELT13X4.4-Z	.512±.010	.126±.004	.047±.002	.409±.008	.079±.004	.426±.008	.130±.004	.298±.006	.012
PC50ELT13X4.4-Z									
PC33ELT13X4.4-Z									

Part No. (ELH+PLT)	Effective parameter							Electrical characteristics	
	C <sub>1</sub>	g <sub>e</sub>	A <sub>e</sub>	V <sub>e</sub>	A <sub>min.</sub>	A <sub>cw</sub>	Wt	AL-value (nH/N <sup>2</sup> )*	
	(mm <sup>-1</sup> )	(mm)	(mm <sup>2</sup> )	(mm <sup>3</sup> )	(mm <sup>2</sup> )	(mm <sup>2</sup> )	(g)	Without air gap	With air gap
PC44ELT11X3-Z								2100±25%	
PC47ELT11X3-Z								2100±25%	50±3%
PC95ELT11X3-Z	0.702	11.7	16.6	194	15.9	3.20	1.1	2590±25%	80±5%
PC50ELT11X3-Z								1640±25%	125±7%
PC33ELT11X3-Z								1640±25%	540±15%**
PC44ELT11X4-Z								2040±25%	
PC47ELT11X4-Z								2040±25%	50±3%
PC95ELT11X4-Z	0.826	13.7	16.5	226	15.9	6.39	1.3	2400±25%	80±5%
PC50ELT11X4-Z								1470±25%	125±7%
PC33ELT11X4-Z								1470±25%	530±15%**
PC44ELT13X3.4-Z								2800±25%	
PC47ELT13X3.4-Z								2800±25%	63±3%
PC95ELT13X3.4-Z	0.578	13.4	23.2	312	22.4	3.77	1.8	3390±25%	100±5%
PC50ELT13X3.4-Z								2090±25%	160±7%
PC33ELT13X3.4-Z								2090±25%	740±15%**
PC44ELT13X4.4-Z								2670±25%	
PC47ELT13X4.4-Z								2670±25%	63±3%
PC95ELT13X4.4-Z	0.667	15.4	23.1	357	22.4	7.54	2.0	3160±25%	100±5%
PC50ELT13X4.4-Z								1890±25%	160±7%
PC33ELT13X4.4-Z								1890±25%	720±15%**

\* AL-value: 1kHz, 0.5mA, 100Ts

\*\* Only PC95 material

# ELT CORES

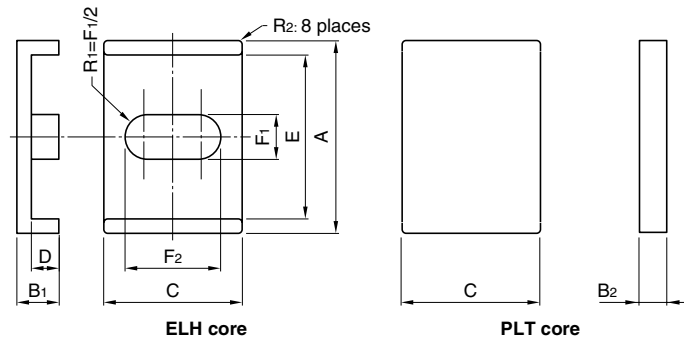
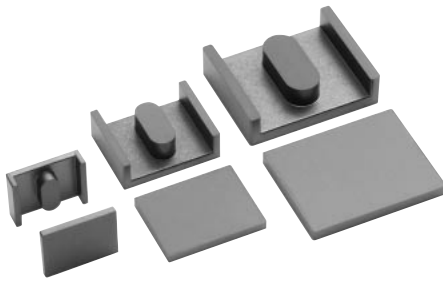

Part No. (ELH+PLT)	Dimensions in mm / inches								
	A	B <sub>1</sub>	B <sub>2</sub>	C	D	E	F <sub>1</sub>	F <sub>2</sub>	R <sub>2</sub>
PC44ELT15.5X4.3-Z									
PC47ELT15.5X4.3-Z	15.50±0.30	2.92±0.10	1.42±0.10	12.40±0.25	1.50±0.10	12.92±0.25	3.92±0.10	9.01±0.20	0.30
PC95ELT15.5X4.3-Z	.610±.012	.115±.004	.056±.004	.488±.010	.059±.004	.509±.010	.154±.004	.355±.008	.012
PC50ELT15.5X4.3-Z									
PC33ELT15.5X4.3-Z									
PC44ELT15.5X5.8-Z									
PC47ELT15.5X5.8-Z	15.50±0.30	4.42±0.10	1.42±0.10	12.40±0.25	3.00±0.10	12.92±0.25	3.92±0.10	9.01±0.20	0.30
PC95ELT15.5X5.8-Z	.610±.012	.174±.004	.056±.004	.488±.010	.118±.004	.509±.010	.154±.004	.355±.008	.012
PC50ELT15.5X5.8-Z									
PC33ELT15.5X5.8-Z									
PC44ELT18X5.3-Z									
PC47ELT18X5.3-Z	18.00±0.30	3.65±0.10	1.65±0.10	14.40±0.25	2.00±0.10	15.00±0.30	4.55±0.10	10.47±0.20	0.30
PC95ELT18X5.3-Z	.709±.012	.144±.004	.065±.004	.567±.010	.079±.004	.591±.012	.179±.004	.412±.008	.012
PC50ELT18X5.3-Z									
PC33ELT18X5.3-Z									
PC44ELT18X7.3-Z									
PC47ELT18X7.3-Z	18.00±0.30	5.65±0.10	1.65±0.10	14.40±0.25	4.00±0.15	15.00±0.30	4.55±0.10	10.47±0.20	0.30
PC95ELT18X7.3-Z	.709±.012	.222±.004	.065±.004	.567±.010	.157±.006	.591±.012	.179±.004	.412±.008	.012
PC50ELT18X7.3-Z									
PC33ELT18X7.3-Z									

Part No. (ELH+PLT)	Effective parameter							Electrical characteristics	
	C <sub>1</sub> (mm <sup>-1</sup> )	ρ <sub>e</sub> (mm)	A <sub>e</sub> (mm <sup>2</sup> )	V <sub>e</sub> (mm <sup>3</sup> )	A <sub>min.</sub> (mm <sup>2</sup> )	A <sub>cw</sub> (mm <sup>2</sup> )	Wt (g)	AL-value (nH/N <sup>2</sup> )*	
								Without air gap	With air gap
PC44ELT15.5X4.3-Z								3450±25%	
PC47ELT15.5X4.3-Z								3450±25%	63±3%
PC95ELT15.5X4.3-Z	0.503	16.6	33.1	550	31.9	6.75	3.0	4340±25%	100±3%
PC50ELT15.5X4.3-Z								2560±25%	160±5%
PC33ELT15.5X4.3-Z								2560±25%	1020±15%**
PC44ELT15.5X5.8-Z								3080±25%	63±3%
PC47ELT15.5X5.8-Z								3080±25%	100±3%
PC95ELT15.5X5.8-Z	0.597	19.6	32.9	646	31.9	13.5	3.5	3680±25%	160±5%
PC50ELT15.5X5.8-Z								2250±25%	
PC33ELT15.5X5.8-Z								2250±25%	990±15%**
PC44ELT18X5.3-Z								4200±25%	80±3%
PC47ELT18X5.3-Z								4200±25%	125±3%
PC95ELT18X5.3-Z	0.446	19.8	44.5	882	43.0	10.5	5.0	5330±25%	200±5%
PC50ELT18X5.3-Z								2750±25%	
PC33ELT18X5.3-Z								2750±25%	1330±15%**
PC44ELT18X7.3-Z								3800±25%	80±3%
PC47ELT18X7.3-Z								3800±25%	125±3%
PC95ELT18X7.3-Z	0.538	23.8	44.3	1050	43.0	20.9	6.0	4760±25%	200±5%
PC50ELT18X7.3-Z								2400±25%	
PC33ELT18X7.3-Z								2400±25%	1280±15%**

\* AL-value: 1kHz, 0.5mA, 100Ts

\*\* Only PC95 material



# ELT CORES

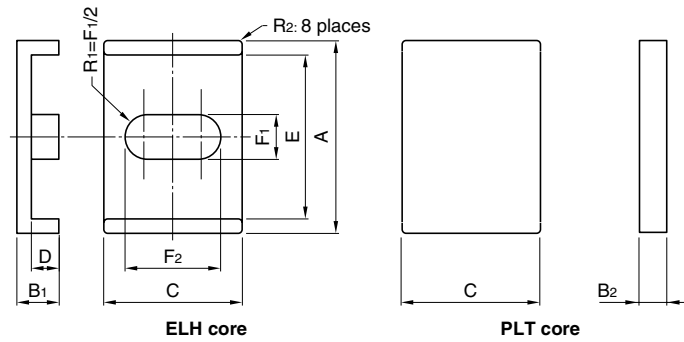
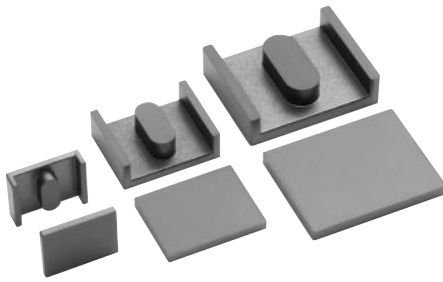

Part No. (ELH+PLT)	Dimensions in								
	mm		inches						
	A	B1	B2	C	D	E	F1	F2	R2
PC44ELT20X5.7-Z									
PC47ELT20X5.7-Z	20.00±0.35	3.83±0.10	1.83±0.10	16.00±0.30	2.00±0.10	16.67±0.30	5.06±0.15	11.63±0.20	0.50
PC95ELT20X5.7-Z	.787±.014	.151±.004	.072±.004	.630±.012	.079±.004	.656±.012	.199±.006	.458±.008	.020
PC50ELT20X5.7-Z									
PC33ELT20X5.7-Z									
PC44ELT20X7.7-Z									
PC47ELT20X7.7-Z	20.00±0.35	5.83±0.15	1.83±0.10	16.00±0.30	4.00±0.15	16.67±0.30	5.06±0.15	11.63±0.20	0.50
PC95ELT20X7.7-Z	.787±.014	.230±.006	.072±.004	.630±.012	.157±.006	.656±.012	.199±.006	.458±.008	.020
PC50ELT20X7.7-Z									
PC33ELT20X7.7-Z									
PC44ELT22X6-Z									
PC47ELT22X6-Z	22.00±0.40	4.02±0.10	2.02±0.10	17.60±0.30	2.00±0.10	18.33±0.35	5.56±0.15	12.79±0.25	0.50
PC95ELT22X6-Z	.866±.016	.158±.004	.080±.004	.693±.012	.079±.004	.722±.014	.219±.006	.504±.010	.020
PC50ELT22X6-Z									
PC33ELT22X6-Z									
PC44ELT22X8-Z									
PC47ELT22X8-Z	22.00±0.40	6.02±0.15	2.02±0.10	17.60±0.30	4.00±0.15	18.33±0.35	5.56±0.15	12.79±0.25	0.50
PC95ELT22X8-Z	.866±.016	.237±.006	.080±.004	.693±.012	.157±.006	.722±.014	.219±.006	.504±.010	.020
PC50ELT22X8-Z									
PC33ELT22X8-Z									

Part No. (ELH+PLT)	Effective parameter							Electrical characteristics	
	C <sub>1</sub>	ϕ <sub>e</sub>	A <sub>e</sub>	V <sub>e</sub>	A <sub>min.</sub>	A <sub>cw</sub>	Wt	AL-value (nH/N <sup>2</sup> )*	
	(mm <sup>-1</sup> )	(mm)	(mm <sup>2</sup> )	(mm <sup>3</sup> )	(mm <sup>2</sup> )	(mm <sup>2</sup> )	(g)	Without air gap	With air gap
PC44ELT20X5.7-Z								5000±25%	80±3%
PC47ELT20X5.7-Z								5000±25%	125±3%
PC95ELT20X5.7-Z	0.393	21.6	54.9	1180	52.9	11.6	6.7	6270±25%	200±5%
PC50ELT20X5.7-Z								3200±25%	1620±15%**
PC33ELT20X5.7-Z								3200±25%	
PC44ELT20X7.7-Z								4340±25%	80±3%
PC47ELT20X7.7-Z								4340±25%	125±3%
PC95ELT20X7.7-Z	0.469	25.6	54.6	1400	52.9	23.2	7.8	5630±25%	200±5%
PC50ELT20X7.7-Z								2800±25%	1560±15%**
PC33ELT20X7.7-Z								2800±25%	
PC44ELT22X6-Z								5750±25%	100±3%
PC47ELT22X6-Z								5750±25%	160±3%
PC95ELT22X6-Z	0.351	23.4	66.6	1560	64.2	12.8	9.0	7250±25%	250±5%
PC50ELT22X6-Z								3800±25%	1910±15%**
PC33ELT22X6-Z								3800±25%	
PC44ELT22X8-Z								5280±25%	100±3%
PC47ELT22X8-Z								5280±25%	160±3%
PC95ELT22X8-Z	0.413	27.3	66.2	1810	64.2	25.5	10	6540±25%	250±5%
PC50ELT22X8-Z								3240±25%	1850±15%**
PC33ELT22X8-Z								3240±25%	

\* AL-value: 1kHz, 0.5mA, 100Ts

\*\* Only PC95 material

## ELT CORES

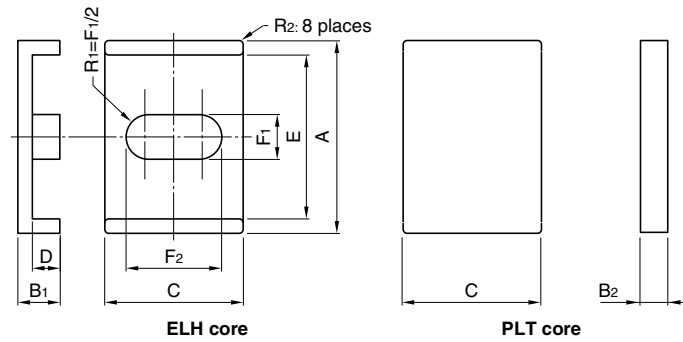
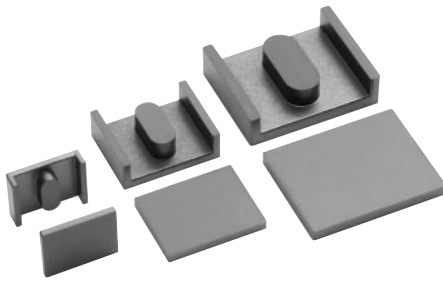

Part No. (ELH+PLT)	Dimensions in								
	A	B1	B2	C	D	E	F1	F2	R2
PC44ELT25X6.6-Z									
PC47ELT25X6.6-Z	25.00±0.45	4.29±0.10	2.29±0.10	20.00±0.35	2.00±0.10	20.83±0.35	6.32±0.15	14.54±0.25	0.50
PC95ELT25X6.6-Z	.984±.018	.169±.004	.090±.004	.787±.014	.079±.004	.820±.014	.249±.006	.572±.010	.020
PC50ELT25X6.6-Z									
PC33ELT25X6.6-Z									
PC44ELT25X8.6-Z									
PC47ELT25X8.6-Z	25.00±0.45	6.29±0.15	2.29±0.10	20.00±0.35	4.00±0.15	20.83±0.35	6.32±0.15	14.54±0.25	0.50
PC95ELT25X8.6-Z	.984±.018	.248±.006	.090±.004	.787±.014	.157±.006	.820±.014	.249±.006	.572±.010	.020
PC50ELT25X8.6-Z									
PC33ELT25X8.6-Z									

Part No. (ELH+PLT)	Effective parameter							Electrical characteristics	
	C1	∅e	Ae	Ve	Amin.	Acw	Wt	AL-value (nH/N <sup>2</sup> )*	
	(mm <sup>-1</sup> )	(mm)	(mm <sup>2</sup> )	(mm <sup>3</sup> )	(mm <sup>2</sup> )	(mm <sup>2</sup> )	(g)	Without air gap	With air gap
PC44ELT25X6.6-Z								7000±25%	
PC47ELT25X6.6-Z								7000±25%	100±3%
PC95ELT25X6.6-Z	0.302	26.0	86.0	2230	83.0	14.5	13	8600±25%	160±3%
PC50ELT25X6.6-Z								4600±25%	250±5%
PC33ELT25X6.6-Z								4600±25%	2430±15%**
PC44ELT25X8.6-Z								6110±25%	
PC47ELT25X8.6-Z								6110±25%	100±3%
PC95ELT25X8.6-Z	0.350	30.0	85.6	2570	83.0	29.0	15	7540±25%	160±3%
PC50ELT25X8.6-Z								4090±25%	250±5%
PC33ELT25X8.6-Z								4090±25%	2340±15%**

\* AL-value: 1kHz, 0.5mA, 100Ts

\*\* Only PC95 material

## PQI CORES

Part No. (HPQ+PQD)	Dimensions in							
	A <sub>1</sub>	A <sub>2</sub>	B	øC	D	E min.	H	I
PC44PQI16/7.8Z-12								
PC47PQI16/7.8Z-12	16.40±0.30	11.20±0.30	14.40±0.30	7.00±0.20	5.40±0.10	9.60	3.05±0.15	2.35±0.10
PC95PQI16/7.8Z-12	.646±.012	.441±.012	.567±.012	.276±.008	.213±.004	.378	.120±.006	.093±.004
PC50PQI16/7.8Z-12								
PC33PQI16/7.8Z-12								
PC44PQI20/9Z-12								
PC47PQI20/9Z-12	20.50±0.40	14.00±0.40	18.00±0.40	8.80±0.20	6.00±0.10	12.00	3.05±0.15	2.95±0.10
PC95PQI20/9Z-12	.807±.016	.551±.016	.709±.016	.346±.008	.236±.004	.472	.120±.006	.116±.004
PC50PQI20/9Z-12								
PC33PQI20/9Z-12								
PC44PQI26/12Z-12								
PC47PQI26/12Z-12	26.50±0.45	19.00±0.45	22.50±0.45	12.00±0.20	7.30±0.10	15.50	3.10±0.15	4.20±0.10
PC95PQI26/12Z-12	1.043±.018	.748±.018	.886±.018	.472±.008	.287±.004	.610	.122±.006	.165±.004
PC50PQI26/12Z-12								
PC33PQI26/12Z-12								

Part No. (HPQ+PQD)	Effective parameter							Electrical characteristics	
	C <sub>1</sub>	e	A <sub>e</sub>	V <sub>e</sub>	A <sub>min.</sub>	A <sub>cw</sub>	Wt	AL-value (nH/N <sup>2</sup> ) <sup>*</sup>	
	(mm <sup>-1</sup> )	(mm)	(mm <sup>2</sup> )	(mm <sup>3</sup> )	(mm <sup>2</sup> )	(mm <sup>2</sup> )	(g)	Without air gap	With air gap
PC44PQI16/7.8Z-12								4100±25%	
PC47PQI16/7.8Z-12								4100±25%	63±3%
PC95PQI16/7.8Z-12	0.467	19.5	41.8	815	37.6	11.3	5.0	4910±25%	100±5%
PC50PQI16/7.8Z-12								2700±25%	160±7%
PC33PQI16/7.8Z-12								2700±25%	1200±15%**
PC44PQI20/9Z-12								5600±25%	
PC47PQI20/9Z-12								5600±25%	100±3%
PC95PQI20/9Z-12	0.346	22.9	66.0	1510	59.3	14.0	9.0	7070±25%	160±5%
PC50PQI20/9Z-12								3670±25%	250±7%
PC33PQI20/9Z-12								3670±25%	1830±15%**
PC44PQI26/12Z-12								9700±25%	
PC47PQI26/12Z-12								9700±25%	100±3%
PC95PQI26/12Z-12	0.224	27.7	123	3410	109	16.3	21	11950±25%	160±3%
PC50PQI26/12Z-12								6200±25%	250±5%
PC33PQI26/12Z-12								6200±25%	3280±15%**

\* AL-value: 1kHz, 0.5mA, 100Ts

\*\* Only PC95 material

# EIR CORES

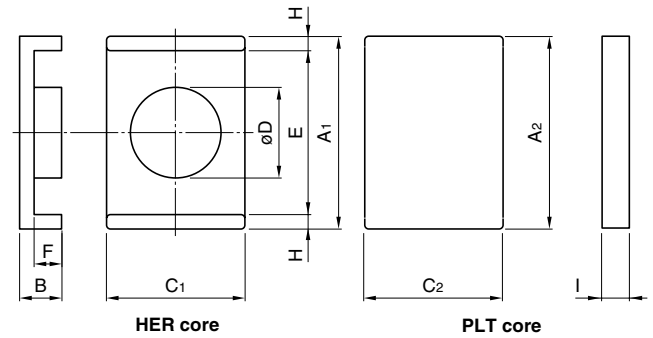
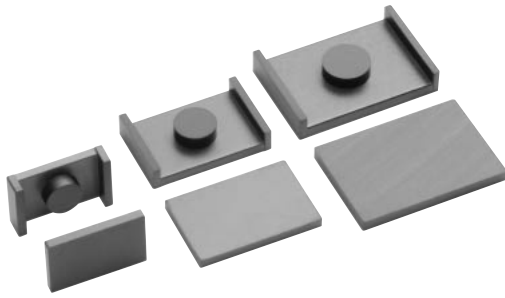

Part No. (HER+PLT)	Dimensions in		C <sub>1</sub>	øD	E	F	H	A <sub>2</sub>	C <sub>2</sub>	I
	A <sub>1</sub>	B								
PC44EIR14/4.5/9-Z										
PC47EIR14/4.5/9-Z	13.85±0.25	3.20±0.10	9.00±0.20	5.20±0.10	11.35±0.15	1.90±0.10	1.25	14.00±0.20	9.20±0.20	1.30±0.10
PC95EIR14/4.5/9-Z	.545±.010	.126±.004	.354±.008	.205±.004	.447±.006	.075±.004	.049	.551±.008	.362±.008	.051±.004
PC50EIR14/4.5/9-Z										
PC33EIR14/4.5/9-Z										
PC44EIR18/5/12-Z										
PC47EIR18/5/12-Z	18.15±0.30	3.50±0.10	12.00±0.20	6.00±0.10	15.75±0.25	2.00±0.10	1.20	18.20±0.25	12.20±0.20	1.50±0.10
PC95EIR18/5/12-Z	.715±.012	.138±.004	.472±.008	.236±.004	.620±.010	.079±.004	.047	.717±.010	.480±.008	.059±.004
PC50EIR18/5/12-Z										
PC33EIR18/5/12-Z										
PC44EIR22/5.5/15-Z										
PC47EIR22/5.5/15-Z	22.10±0.35	3.75±0.10	15.25±0.25	6.80±0.10	19.70±0.30	2.00±0.10	1.20	22.20±0.30	15.50±0.20	1.75±0.10
PC95EIR22/5.5/15-Z	.870±.014	.148±.004	.600±.010	.268±.004	.776±.012	.079±.004	.047	.874±.012	.610±.008	.069±.004
PC50EIR22/5.5/15-Z										
PC33EIR22/5.5/15-Z										

Part No. (HER+PLT)	Effective parameter							Electrical characteristics	
	C <sub>1</sub>	ℓ <sub>e</sub>	A <sub>e</sub>	V <sub>e</sub>	A <sub>min</sub>	A <sub>cw</sub>	W <sub>t</sub>	AL-value (nH/N <sup>2</sup> )	
	(mm <sup>-1</sup> )	(mm)	(mm <sup>2</sup> )	(mm <sup>3</sup> )	(mm <sup>2</sup> )	(mm <sup>2</sup> )	(g)	Without air gap	With air gap
PC44EIR14/4.5/9-Z								2400±25%	
PC47EIR14/4.5/9-Z								2400±25%	63±3%
PC95EIR14/4.5/9-Z	0.679	15.4	22.7	349	21.2	5.84	2.0	3020±25%	100±5%
PC50EIR14/4.5/9-Z								1800±25%	160±7%
PC33EIR14/4.5/9-Z								1800±25%	680±15%**
PC44EIR18/5/12-Z								2900±25%	
PC47EIR18/5/12-Z								2900±25%	80±3%
PC95EIR18/5/12-Z	0.601	19.7	32.8	645	28.3	9.75	3.8	3690±25%	125±5%
PC50EIR18/5/12-Z								2100±25%	200±7%
PC33EIR18/5/12-Z								2100±25%	890±15%**
PC44EIR22/5.5/15-Z								3400±25%	
PC47EIR22/5.5/15-Z								3400±25%	80±3%
PC95EIR22/5.5/15-Z	0.505	23.2	46.1	1070	36.3	12.9	6.5	4550±25%	125±5%
PC50EIR22/5.5/15-Z								2500±25%	200±7%
PC33EIR22/5.5/15-Z								2500±25%	1130±15%**

\* AL-value: 1kHz, 0.5mA, 100Ts

\*\* Only PC95 material

# ER CORES

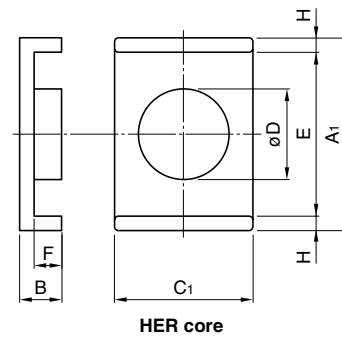
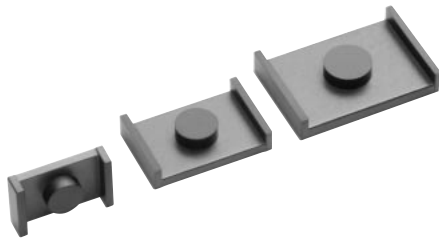

Part No. (HER+HER)	Dimensions in		C <sub>1</sub>	øD	E	F	H
	mm	inches					
PC44ER14/4.5/9-Z							
PC47ER14/4.5/9-Z	13.85±0.25	2.25±0.10	9.00±0.20	5.20±0.10	11.35±0.15	0.95±0.10	1.25
PC95ER14/4.5/9-Z	.545±.010	.089±.004	.354±.008	.205±.004	.447±.006	.037±.004	.049
PC50ER14/4.5/9-Z							
PC33ER14/4.5/9-Z							
PC44ER18/5/12-Z							
PC47ER18/5/12-Z	18.15±0.30	2.50±0.10	12.00±0.20	6.00±0.10	15.75±0.25	1.00±0.10	1.20
PC95ER18/5/12-Z	.715±.012	.098±.004	.472±.008	.236±.004	.620±.010	.039±.004	.047
PC50ER18/5/12-Z							
PC33ER18/5/12-Z							
PC44ER22/5.5/15-Z							
PC47ER22/5.5/15-Z	22.10±0.35	2.75±0.10	15.25±0.25	6.80±0.10	19.70±0.30	1.00±0.10	1.20
PC95ER22/5.5/15-Z	.870±.014	.108±.004	.600±.010	.268±.004	.776±.012	.039±.004	.047
PC50ER22/5.5/15-Z							
PC33ER22/5.5/15-Z							
PC44ER25/5.5/18-Z							
PC47ER25/5.5/18-Z	25.30±0.40	2.75±0.10	18.00±0.40	7.00±0.15	22.90±0.40	1.00±0.10	1.20
PC95ER25/5.5/18-Z	.996±.016	.108±.004	.709±.016	.276±.006	.902±.016	.039±.004	.047
PC50ER25/5.5/18-Z							
PC33ER25/5.5/18-Z							

Part No. (HER+HER)	Effective parameter							Electrical characteristics	
	C <sub>1</sub>	ø e	A <sub>e</sub>	V <sub>e</sub>	A <sub>min.</sub>	A <sub>cw</sub>	Wt	AL-value (nH/N <sup>2</sup> )*	
	(mm <sup>-1</sup> )	(mm)	(mm <sup>2</sup> )	(mm <sup>3</sup> )	(mm <sup>2</sup> )	(mm <sup>2</sup> )	(g)	Without air gap	With air gap
PC44ER14/4.5/9-Z								2400±25%	
PC47ER14/4.5/9-Z								2400±25%	63±3%
PC95ER14/4.5/9-Z	0.679	15.4	22.7	349	21.2	5.84	2.0	3020±25%	100±5%
PC50ER14/4.5/9-Z								1800±25%	160±7%
PC33ER14/4.5/9-Z								1800±25%	680±15%**
PC44ER18/5/12-Z								2900±25%	
PC47ER18/5/12-Z								2900±25%	80±3%
PC95ER18/5/12-Z	0.601	19.7	32.8	645	28.3	9.75	3.8	3690±25%	125±5%
PC50ER18/5/12-Z								2100±25%	200±7%
PC33ER18/5/12-Z								2100±25%	890±15%**
PC44ER22/5.5/15-Z								3400±25%	
PC47ER22/5.5/15-Z								3400±25%	80±3%
PC95ER22/5.5/15-Z	0.505	23.2	46.1	1070	36.3	12.9	6.5	4550±25%	125±5%
PC50ER22/5.5/15-Z								2500±25%	200±7%
PC33ER22/5.5/15-Z								2500±25%	1130±15%**
PC44ER25/5.5/18-Z								3600±25%	
PC47ER25/5.5/18-Z								3600±25%	80±3%
PC95ER25/5.5/18-Z	0.486	26.1	53.7	1400	38.5	15.9	8.5	4640±25%	125±3%
PC50ER25/5.5/18-Z								2600±25%	200±5%
PC33ER25/5.5/18-Z								2600±25%	1140±15%**

\* AL-value: 1kHz, 0.5mA, 100Ts

\*\* Only PC95 material

# EI CORES

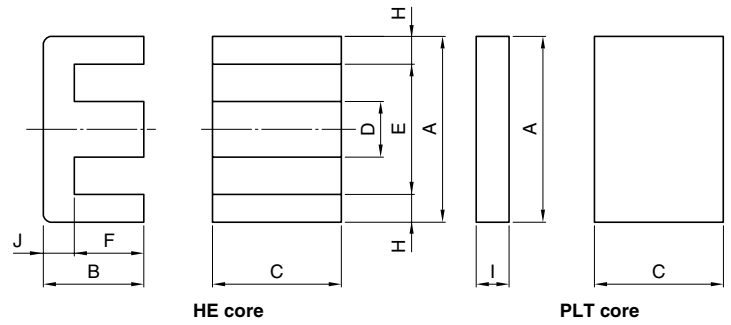
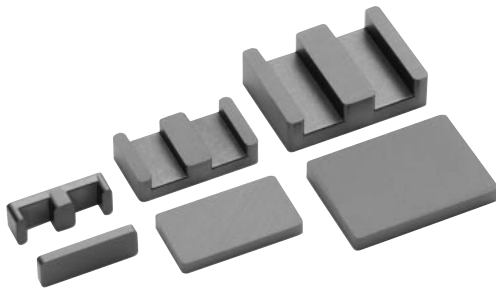

Part No. (HE+PLT)	Dimensions in		C	D	E	F	H	I	J
	A	B							
PC44EI14/5/5-Z									
PC47EI14/5/5-Z	14.00±0.30	3.50±0.10	5.00±0.10	3.00±0.10	11.00±0.25	2.00±0.10	1.50	1.50±0.05	1.50
PC95EI14/5/5-Z	.551±.012	.138±.004	.197±.004	.118±.004	.433±.010	.079±.004	.059	.059±.002	.059
PC50EI14/5/5-Z									
PC33EI14/5/5-Z									
PC44EI18/6/10-Z									
PC47EI18/6/10-Z	18.00±0.35	4.00±0.10	10.00±0.20	4.00±0.10	14.00±0.30	2.00±0.10	2.00	2.00±0.05	2.00
PC95EI18/6/10-Z	.709±.014	.157±.004	.394±.008	.157±.004	.551±.012	.079±.004	.079	.079±.002	.079
PC50EI18/6/10-Z									
PC33EI18/6/10-Z									
PC44EI22/8/16-Z									
PC47EI22/8/16-Z	21.80±0.40	5.70±0.10	15.80±0.30	5.00±0.10	16.80±0.40	3.20±0.10	2.50	2.50±0.05	2.50
PC95EI22/8/16-Z	.858±.016	.224±.004	.622±.012	.197±.004	.661±.016	.126±.004	.098	.098±.002	.098
PC50EI22/8/16-Z									
PC33EI22/8/16-Z									

Part No. (HE+PLT)	Effective parameter							Electrical characteristics	
	C <sub>1</sub>	ℓ <sub>e</sub>	A <sub>e</sub>	V <sub>e</sub>	A <sub>min</sub>	A <sub>cw</sub>	Wt	AL-value (nH/N <sup>2</sup> )*	
	(mm <sup>-1</sup> )	(mm)	(mm <sup>2</sup> )	(mm <sup>3</sup> )	(mm <sup>2</sup> )	(mm <sup>2</sup> )	(g)	Without air gap	With air gap
PC44EI14/5/5-Z								1500±25%	
PC47EI14/5/5-Z								1500±25%	63±3%
PC95EI14/5/5-Z	1.11	16.7	15.0	251	15.0	8.00	1.3	1970±25%	100±5%
PC50EI14/5/5-Z								1150±25%	160±7%
PC33EI14/5/5-Z								1150±25%	470±15%**
PC44EI18/6/10-Z								3800±25%	
PC47EI18/6/10-Z								3800±25%	100±3%
PC95EI18/6/10-Z	0.507	20.3	40.0	811	40.0	10.0	4.4	4720±25%	160±3%
PC50EI18/6/10-Z								2450±25%	250±5%
PC33EI18/6/10-Z								2450±25%	1220±15%**
PC44EI22/8/16-Z								6400±25%	
PC47EI22/8/16-Z								6400±25%	160±3%
PC95EI22/8/16-Z	0.330	26.1	79.0	2060	79.0	18.9	11	8010±25%	250±3%
PC50EI22/8/16-Z								4300±25%	315±3%
PC33EI22/8/16-Z								4300±25%	2300±15%**

\* AL-value: 1kHz, 0.5mA, 100Ts

\*\* Only PC95 material

# ORIGINAL CORES

## Cores

PQ20/16 to PQ50/50  
LP23/8 to LP32/13  
EPC10 to EPC30  
EP7 to EP20

## Bobbins

BPQ20/16 to BPQ50/50  
BLP23/8 to BLP32/13  
BEPC10 to BEPC30  
BEP7 to BEP20

## Accessories

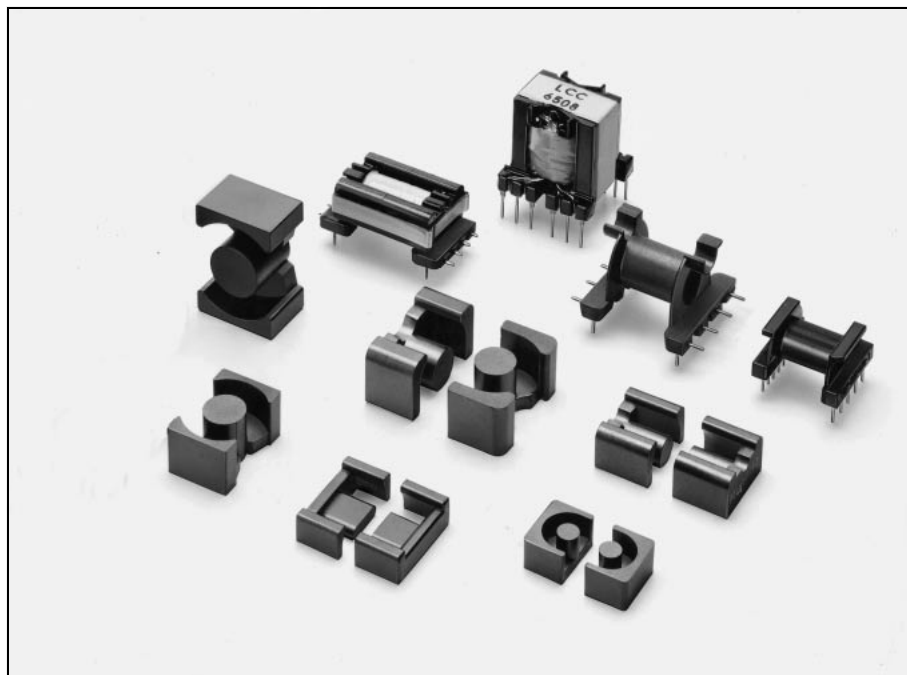

## Ordering Code System

### Cores

Material PC44 Size of PQ core PQ 26/25 AL-value Z: without air gap Z □: with air gap  
 Number of Lead Slot 12 Type

### Bobbins

Symbol of Bobbin B Size of PQ core PQ 26/25 Code of Bobbin Material 1112 Type of Terminal Pin CP Number of Terminal Pin F Number of Section R

### Accessories

Symbol of Accessory F Size of PQ core PQ 26/25 Type of Accessory A

# PQ CORES

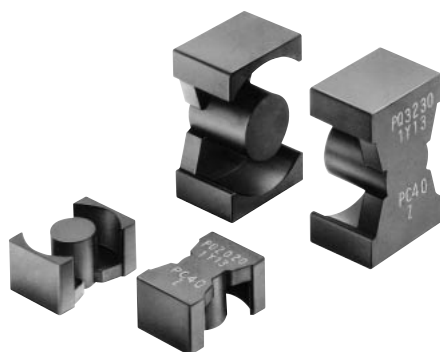

DE. PAT. 2,944,583  
 DE. DES. 15,655  
 EP. PAT. 26,104(DE, FR, GB, NL)  
 GB. PAT. 2,035,706  
 GB. DES. 990,685  
 JP. U. M 1,589,580  
 JP. U. M 1,621,895  
 JP. U. M PUB.  
 85(60)-3556 1,647,781  
 JP. U. M PUB.  
 86(61)-5779 1655608  
 JP. DES. 580,081  
 JP. DES. 649,618  
 KR. U. M 23,487  
 NL. PAT. 178,826  
 NL. DES. 5,777  
 US. PAT. 4,352,080  
 US. DES. 264,959

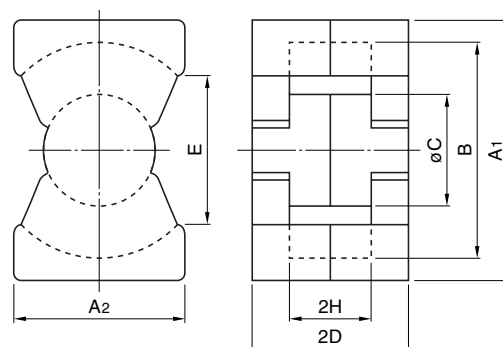

Part No.	Dimensions in		B	øC	2D	E	2H
	mm	inches					
<b>PC44PQ20/16Z-12</b>	20.5±0.4 .807±.016	14.0±0.4 .551±.016	18.0±0.4 .709±.016	8.8±0.2 .346±.008	16.2±0.2 .638±.008	12.0 .472	10.3±0.3 .406±.012
<b>PC44PQ20/20Z-12</b>	20.5±0.4 .807±.016	14.0±0.4 .551±.016	18.0±0.4 .709±.016	8.8±0.2 .346±.008	20.2±0.2 .795±.008	12.0 .472	14.3±0.3 .563±.012
<b>PC50PQ20/20Z-12</b>	20.5±0.4 .807±.016	14.0±0.4 .551±.016	18.0±0.4 .709±.016	8.8±0.2 .346±.008	20.2±0.2 .795±.008	12.0 .472	14.3±0.3 .563±.012
<b>PC44PQ26/20Z-12</b>	26.5±0.45 1.043±.018	19.0±0.45 .748±.018	22.5±0.45 .886±.018	12.0±0.2 .472±.008	20.15±0.25 .793±.010	15.5 .610	11.5±0.3 .453±.012
<b>PC44PQ26/25Z-12</b>	26.5±0.45 1.043±.018	19.0±0.45 .748±.018	22.5±0.45 .886±.018	12.0±0.2 .472±.008	24.75±0.25 .974±.010	15.5 .610	16.1±0.3 .634±.012
<b>PC50PQ26/25Z-12</b>	26.5±0.45 1.043±.018	19.0±0.45 .748±.018	22.5±0.45 .886±.018	12.0±0.2 .472±.008	24.75±0.25 .974±.010	15.5 .610	16.1±0.3 .634±.012
<b>PC44PQ32/20Z-12</b>	32.0±0.5 1.260±.020	22.0±0.5 .866±.020	27.5±0.5 1.083±.020	13.45±0.25 .530±.010	20.55±0.25 .809±.010	19.0 .748	11.5±0.3 .453±.012
<b>PC44PQ32/30Z-12</b>	32.0±0.5 1.260±.020	22.0±0.5 .866±.020	27.5±0.5 1.083±.020	13.45±0.25 .530±.010	30.35±0.25 1.195±.010	19.0 .748	21.3±0.3 .839±.012

Part No.	Effective parameter				Electrical characteristics		Core loss (W) max. 100kHz, 200mT, 100°C	Wt (g)	Bobbin item
	C <sub>1</sub> (mm <sup>-1</sup> )	A <sub>e</sub> (mm <sup>2</sup> )	l <sub>e</sub> (mm)	V <sub>e</sub> (mm <sup>3</sup> )	Al-value (nH/N <sup>2</sup> ) <sup>*</sup>				
				Without air gap	With air gap				
<b>PC44PQ20/16Z-12</b>	0.605	62	37.4	2310	3880±25%	100±5% 250±7% 400±10%	0.84	13	BPQ20/16-1114CPFR
<b>PC44PQ20/20Z-12</b>	0.738	62	45.4	2790	3150±25%	100±5% 250±7% 400±10%	1.02	15	BPQ20/20-1114CPFR
<b>PC50PQ20/20Z-12</b>	0.738	62	45.4	2790	2000±25%	100±5% 160±5% 250±7%	0.33***	15	BPQ20/20-1114CPFR
<b>PC44PQ26/20Z-12</b>	0.391	119	46.3	5490	6170±25%	160±5% 315±5% 630±10%	1.94	31	BPQ26/20-1112CPFR
<b>PC44PQ26/25Z-12</b>	0.472	118	55.5	6530	5250±25%	160±5% 315±5% 630±10%	2.32	36	BPQ26/25-1112CPFR
<b>PC50PQ26/25Z-12</b>	0.472	118	55.5	6530	3200±25%	100±5% 250±5% 400±7%	0.76***	36	BPQ26/25-1112CPFR
<b>PC44PQ32/20Z-12</b>	0.326	170	55.5	9420	7310±25%	160±5% 315±5% 630±7%	2.92	42	BPQ32/20-1112CPFR
<b>PC44PQ32/30Z-12</b>	0.464	161	74.6	12000	5140±25%	160±5% 315±5% 630±7%	3.92	55	BPQ32/30-1112CPFR

\* Al-value: 1kHz, 0.5mA, 100Ts  
 \*\* Core loss: 100kHz, 150mT, 100°C  
 \*\*\* Core loss: 500kHz, 50mT, 100°C



## PQ CORES



DE. PAT. 2,944,583  
 DE. DES. 15,655  
 EP. PAT. 26,104(DE, FR, GB, NL)  
 GB. PAT. 2,035,706  
 GB. DES. 990,685  
 JP. U. M 1,589,580  
 JP. U. M 1,621,895  
 JP. U. M PUB.  
 85(60)-3556 1,647,781  
 JP. U. M PUB.  
 86(61)-5779 1655608  
 JP. DES. 580,081  
 JP. DES. 649,618  
 KR. U. M 23,487  
 NL. PAT. 178,826  
 NL. DES. 5,777  
 US. PAT. 4,352,080  
 US. DES. 264,959

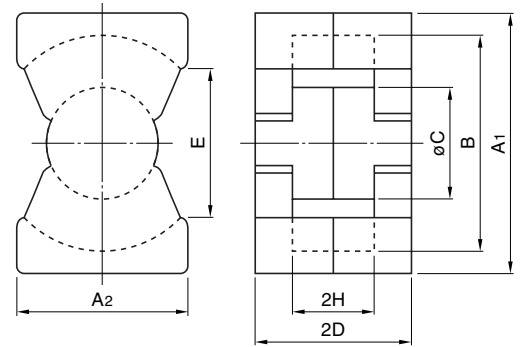

Part No.	Dimensions in		B	øC	2D	E	2H
	mm	inches					
PC44PQ35/35Z-12	35.1±0.6	26.0±0.5	32.0±0.5	14.35±0.25	34.75±0.25	23.5	25.0±0.3
	1.382±.024	1.024±.020	1.260±.020	.565±.010	1.368±.010	.925	.984±.012
PC44PQ40/40Z-12	40.5±0.9	28.0±0.6	37.0±0.6	14.9±0.3	39.75±0.25	28.0	29.5±0.3
	1.594±.035	1.102±.024	1.457±.024	.587±.012	1.565±.010	1.102	1.161±.012
PC44PQ50/50Z-12	50.0±0.7	32.5±0.5	44.0±0.7	20.0±0.35	49.95±0.25	31.5	36.1±0.3
	1.969±.028	1.260±.020	1.732±.028	.787±.014	1.967±.010	1.240	1.421±.012

Part No.	Effective parameter				Electrical characteristics			Wt (g)	Bobbin item
	C <sub>1</sub> (mm <sup>-1</sup> )	A <sub>e</sub> (mm <sup>2</sup> )	l <sub>e</sub> (mm)	V <sub>e</sub> (mm <sup>3</sup> )	AL-value (nH/N <sup>2</sup> )*		Core loss (W) max. 100kHz, 200mT, 100°C		
					Without air gap	With air gap			
PC44PQ35/35Z-12	0.448	196	87.9	17300	4860±25%	160±5% 315±5% 630±7%	5.27	73	BPQ35/35-1112CPFR
PC44PQ40/40Z-12	0.508	201	102	20500	4300±25%	160±5% 315±5% 630±7%	6.56	95	BPQ40/40-1112CPFR
PC44PQ50/50Z-12	0.346	328	113	37200	6720±25%	250±5% 400±5% 630±5%	6.10**	195	BPQ50/50-1112CPFR

\* AL-value: 1kHz, 0.5mA, 100Ts

\*\* Core loss: 100kHz, 150mT, 100°C

\*\*\* Core loss: 500kHz, 50mT, 100°C

# PQ BOBBINS

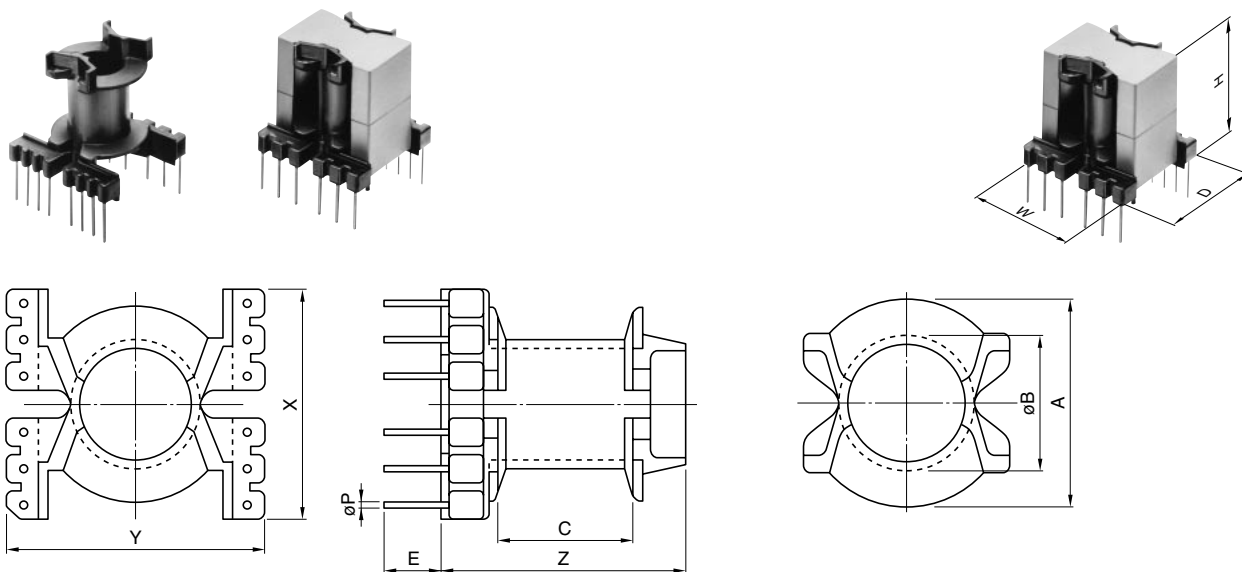

Part No.	Dimensions in <small>mm</small> <small>inches</small>							
	A	øB	C	E	X	Y	Z	t*
BPQ20/16-1114CPFR	17.2 .677	10.95 .431	8.0 .315	6.5 .256	23.0 .906	23.0 .906	18.3 .720	0.8 .031
BPQ20/20-1114CPFR	17.2 .677	10.95 .431	12.0 .472	6.5 .256	23.0 .906	23.0 .906	21.3 .839	0.8 .031
BPQ26/20-1112CPFR	21.6 .850	14.3 .563	9.2 .362	6.5 .256	26.5 1.043	29.3 1.154	21.5 .846	0.8 .031
BPQ26/25-1112CPFR	21.6 .850	14.3 .563	13.8 .543	3.5 .138	26.5 1.043	29.3 1.154	25.1 .988	0.8 .031
BPQ32/20-1112CPFR	26.6 1.047	16.0 .630	8.98 .354	7.0 .276	32.0 1.260	34.0 1.339	22.48 .885	0.9 .035
BPQ32/30-1112CPFR	26.6 1.047	16.0 .630	18.6 .732	7.0 .276	32.0 1.260	34.0 1.339	32.1 1.264	0.9 .035
BPQ35/35-1112CPFR	31.1 1.224	16.9 .665	22.50 .886	7.5 .295	35.0 1.378	39.0 1.535	37.4 1.472	0.9 .035
BPQ40/40-1112CPFR	36.0 1.417	17.5 .689	26.8 1.055	6.5 .256	40.0 1.575	42.0 1.654	44.8 1.764	0.9 .035
BPQ50/50-1112CPFR	42.9 1.689	23.2 .913	30.4 1.197	10.0 .394	51.0 2.008	51.0 2.008	52.0 2.047	1.0 .039

Part No.	Dimensions in mm			Parameter		Wt (g)	Accessory item
	øP (mm)	Terminal pins	W D (mm) H	Aw (mm <sup>2</sup> )	l w (mm)		
BPQ20/16-1114CPFR	0.6	14	23.0 23.0 18.3	23.4	44	2.7	FPQ20/16-A
BPQ20/20-1114CPFR	0.6	14	23.0 23.0 22.3	36.2	44	2.8	FPQ20/20-A
BPQ26/20-1112CPFR	0.8	12	26.5 29.3 21.5	30.7	56.2	4.3	FPQ26/20-A
BPQ26/25-1112CPFR	0.8	12	26.5 29.3 29.1	47.7	56.2	4.9	FPQ26/25-A
BPQ32/20-1112CPFR	1.0	12	32.0 34.0 22.5	42.9	67.1	6.6	FPQ32/20-A
BPQ32/30-1112CPFR	1.0	12	32.0 34.0 32.1	95.3	67.1	7.4	FPQ32/30-A
BPQ35/35-1112CPFR	1.0	12	35.0 39.0 37.4	154.2	75.2	11	FPQ35/35-A
BPQ40/40-1112CPFR	1.0	12	40.0 42.0 44.8	240.0	83.9	14	FPQ40/40-A
BPQ50/50-1112CPFR	1.2	12	51.0 51.0 52.0	313.0	104	22	FPQ50/50-B

UL Grade: 94V-0, Material: FR phenol, Pin material: Steel wire (Solder plated)  
 Maximum number of turns N that can be wound on bobbins, see section of "Maximum number of Turns on Bobbins".  
 \* Minimum thickness of bobbin inside which core is placed, including flanges.

• All specifications are subject to change without notice.

### Connecting Pin Patterns (2.54mm/0.1 inch grids) View in mounting direction

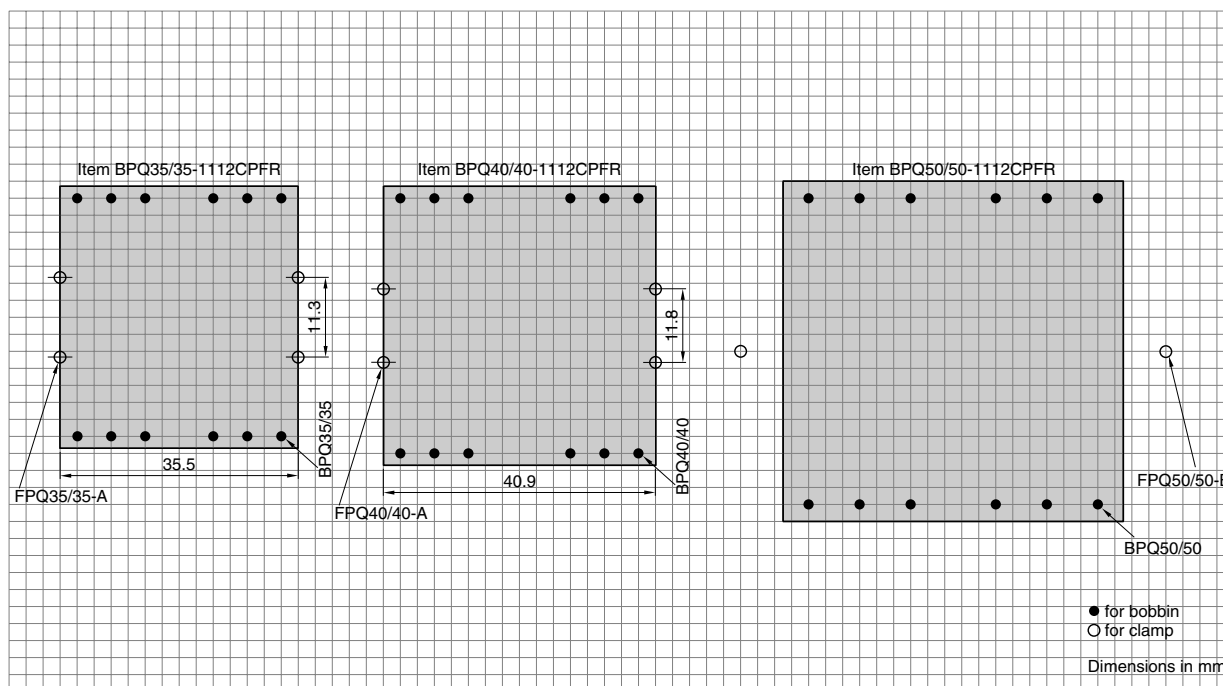
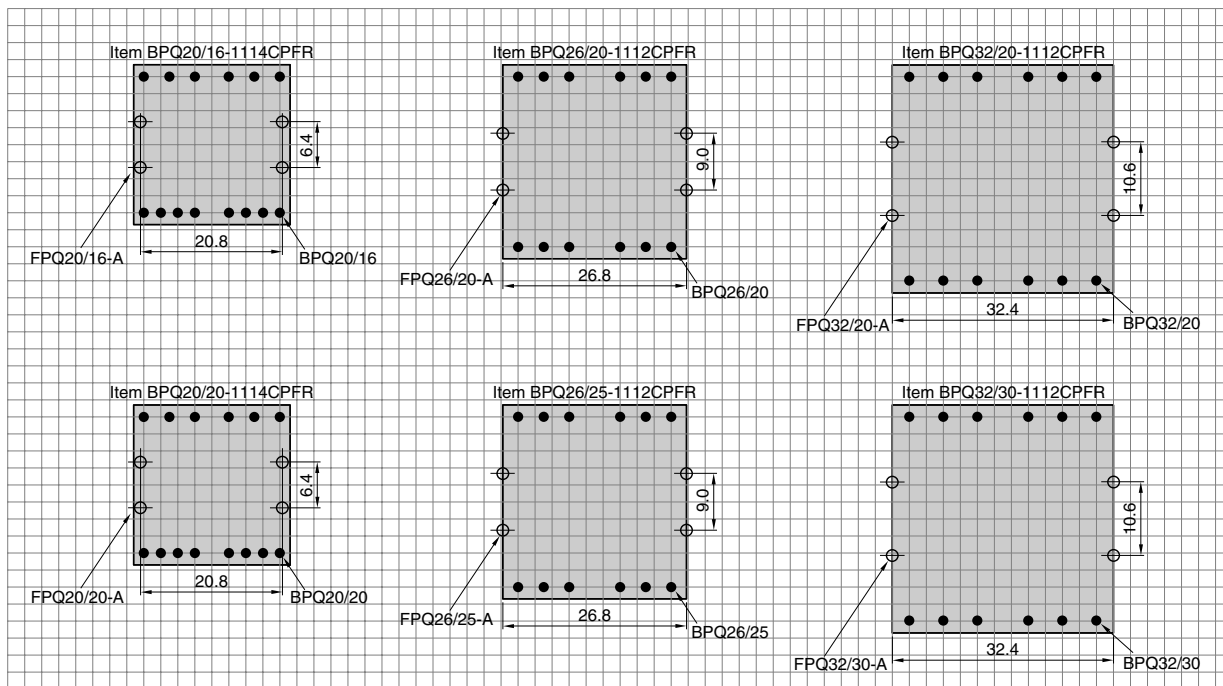

• All specifications are subject to change without notice.

## LP CORES

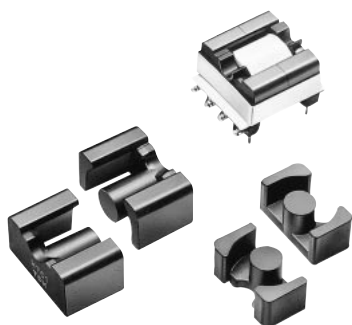

DE. DES. 19,581  
 EP. PAT. 68,745(DE, FR, GB, NL)  
 FR. DES. 201,586  
 GB. DES. 1,007,200  
 JP. U. M PRO. PUB. 82(57)-201,824  
 JP. DES. 630,754  
 NL. DES. 9,767  
 US. PAT. 4,424,504  
 US. DES. 280,810

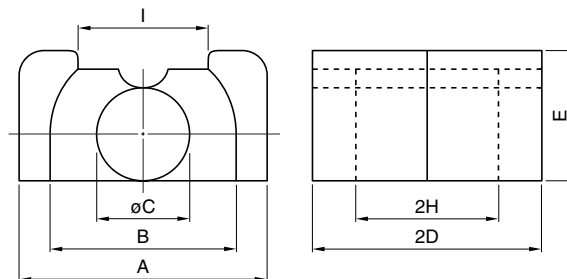

Part No.	Dimensions in		$\phi C$	2D	E	2H	I
	mm	inches					
	A	B					
<b>PC44LP23/8Z-12</b>	16.5±0.3 .650±.012	12.5±0.3 .492±.012	5.7±0.1 .224±.004	23.4±0.2 .921±.008	8.7±0.2 .343±.008	17.4±0.2 .685±.008	9.0±0.5 .354±.020
<b>PC44LP22/13Z-12</b>	25.0±0.4 .984±.016	19.0±0.3 .748±.012	8.6±0.2 .339±.008	22.4±0.2 .882±.008	12.9±0.3 .508±.012	16.4±0.3 .646±.012	13.5±0.5 .531±.020
<b>PC44LP32/13Z-12</b>	25.0±0.4 .984±.016	19.0±0.3 .748±.012	8.6±0.2 .339±.008	31.8±0.2 1.252±.008	12.9±0.3 .508±.012	24.1±0.3 .949±.012	13.5±0.5 .531±.020

Part No.	Effective parameter				Electrical characteristics			Wt (g)	Bobbin item
	$C_1$ (mm <sup>-1</sup> )	$A_e$ (mm <sup>2</sup> )	$\phi_e$ (mm)	$V_e$ (mm <sup>3</sup> )	$AL$ -value (nH/N <sup>2</sup> )*		Core loss (W) max. 100kHz, 200mT, 100°C		
					Without air gap	With air gap			
<b>PC44LP23/8Z-12</b>	1.41	31.3	44.1	1380	1600±25%	63+5% 100+7% 250+13%	0.42	9.6	BLP23/8-018PFR
<b>PC44LP22/13Z-12</b>	0.721	67.9	49.0	3330	3310±25%	100+5% 200+7% 400+10%	1.05	21	BLP22/13-1110CPLFR
<b>PC44LP32/13Z-12</b>	0.909	70.3	64.0	4500	2630±25%	100+5% 200+7% 400+10%	1.38	30	BLP32/13-1110CPLFR

\*  $AL$ -value: 1kHz, 0.5mA, 100Ts

# LP BOBBINS

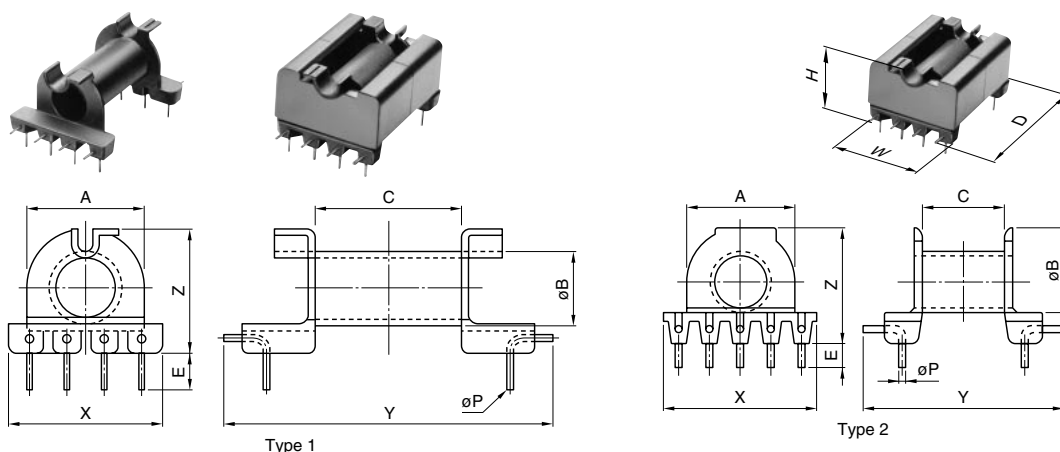

Part No.	Type	Dimensions in mm inches							
		A	B	C	E	X	Y	Z	t**
BLP23/8-018CPLFR	1	12.0 .472	7.7 .303	15.2 .598	4.0 .157	16.5 .650	34.0 1.358	8.45 .333	0.75 .030
BLP22/13-018CPLFR	1	17.6 .693	10.7 .421	14.1 .555	4.0 .157	25.0 .984	31.5 1.240	17.6 .693	0.75 .030
BLP22/13-1110CPLFR*	2	17.6 .693	10.78 .424	13.4 .528	4.0 .157	25.0 .984	32.3 1.272	19.1 .752	0.8 .031
BLP32/13-018CPLFR	1	17.6 .693	10.7 .421	21.8 .858	4.0 .157	25.0 .984	40.6 1.598	17.6 .693	0.75 .030
BLP32/13-1110CPLFR*	2	17.6 .693	10.78 .424	21.1 .835	4.0 .157	25.0 .984	40.6 1.598	19.1 .752	0.8 .031

Part No.	Dimensions in mm			Parameter		Wt (g)	Material	Clamp item
	ØP (mm)	Terminal pins	W D (mm) H	Aw (mm²)	ℓ w (mm)			
BLP23/8-018CPLFR	0.6	8	17.2 34.2 12.5	31.9	30.9	1.9	PPS	FLP23/8-A
BLP22/13-018CPLFR	0.8	8	27 32 17.8	51.5	45.8	3.2	PPS	FLP22/13-A
BLP22/13-1110CPLFR*	0.8	10	25.9 32.3 19.2	45.7	44.5	3.1	FR Phenol	FLP22/13-A
BLP32/13-018CPLFR	0.8	8	27 41 17.8	79.6	45.8	3.7	PPS	FLP32/13-A
BLP32/13-1110CPLFR*	0.8	10	25.9 40.6 19.2	72.0	44.5	3.7	FR Phenol	FLP32/13-A

UL Grade: 94V-0, Pin material: Phosphor bronze wire/Steel wire for "-1110-CPLFR" (Solder plated), Insulating divider's material: NOMEX®  
 Maximum number of turns N that can be wound on bobbins, see section of "Maximum number of Turns on Bobbins".

\* Include 2 pieces of insulating dividers.

Insulating divider for BLP22/13-1110CPLFR  
 Part No.: ILP22/13

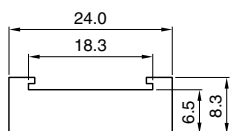

Insulating divider for BLP32/13-1110CPLFR  
 Part No.: ILP32/13

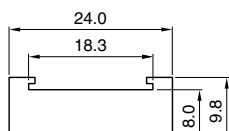

Dimensions in mm

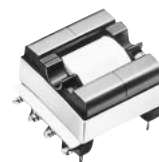

\*\* Minimum thickness of bobbin inside which core is placed, including flanges.

## PIN LAYOUT

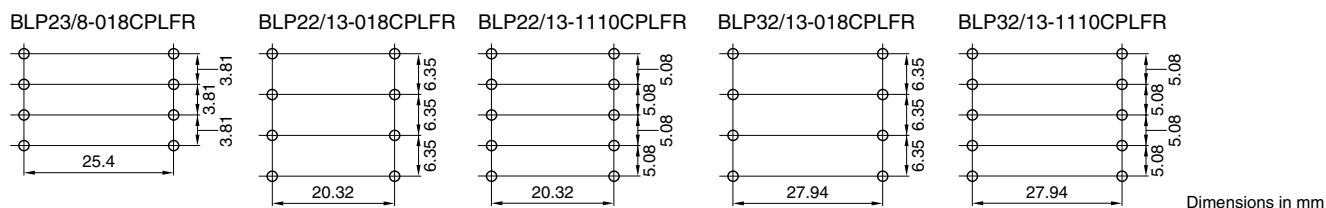

• All specifications are subject to change without notice.

# EPC CORES

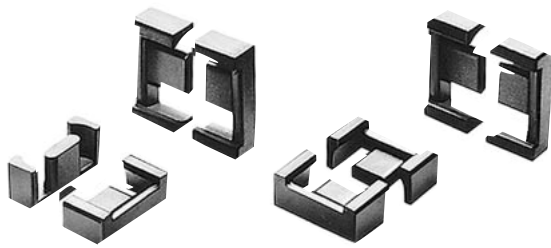

US. PAT. 4,760,366  
 EP. PAT. 245,083(DE, FR, GB, NL)  
 KS. UM 50,836  
 TW. UM 39,406  
 JP. PENDING

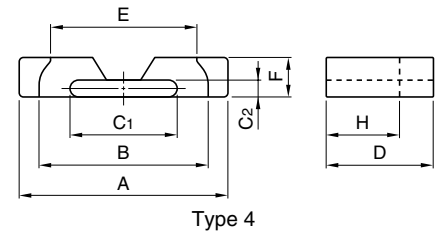
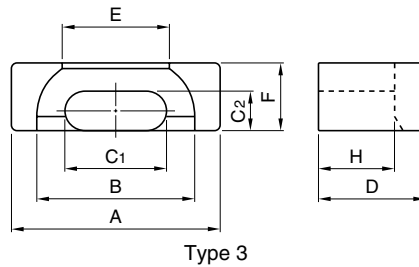
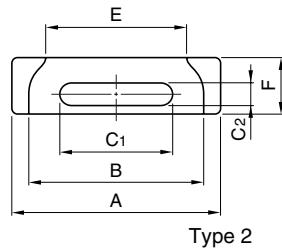
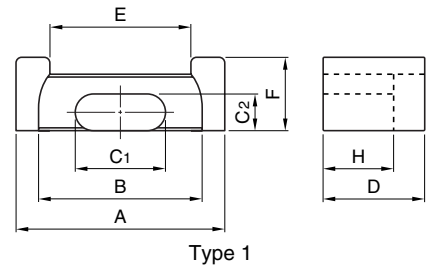

Part No.	Type	Dimensions in							
		mm		inches					
		A	B	C <sub>1</sub>	C <sub>2</sub>	D	E	F	H
			min.				min.		
PC44EPC10-Z	3	10.2±0.2	7.6	5.0±0.1	1.9±0.1	4.05±0.10	5.3	3.4±0.1	2.65±0.10
PC50EPC10-Z		.402±.008	.299	.197±.004	.075±.004	.159±.004	.209	.139±.004	.104±.004
PC44EPC13-Z	1	13.25±0.3	10.5	5.60±0.15	2.05±0.10	6.6±0.2	8.3	4.60±0.15	4.5±0.2
PC50EPC13-Z		.522±.012	.413	.220±.006	.081±.004	.026±.008	.327	.181±.006	.177±.008
PC44EPC17-Z	1	17.6±0.4	14.3	7.70±0.15	2.8±0.1	8.55±0.20	11.5	6.00±0.15	6.05±0.20
PC50EPC17-Z		.693±.016	.563	.303±.006	.110±.004	.337±.008	.453	.236±.006	.238±.008
PC44EPC19-Z	1	19.1±0.4	15.8	8.50±0.15	2.5±0.1	9.75±0.20	13.1	6.00±0.15	7.25±0.20
PC50EPC19-Z		.752±.016	.622	.335±.006	.098±.004	.384±.008	.516	.236±.006	.285±.008
PC44EPC25-Z	1	25.1±0.5	20.65	11.5±0.2	4.0±0.1	12.5±0.2	17.1	8.0±0.2	9.0±0.3
PC50EPC25-Z		.988±.020	.813	.453±.008	.157±.004	.492±.008	.673	.315±.008	.354±.012
PC44EPC25B-Z	2	25.1±0.5	20.4	13.8±0.2	2.50±0.15	11.43±0.15	16.5	6.5±0.2	8.78±0.15
PC50EPC25B-Z		.988±.020	.803	.543±.008	.098±.006	.450±.006	.650	.266±.008	.346±.006
PC44EPC27-Z	1	27.1±0.5	21.6	13.0±0.3	4.0±0.1	16.0±0.2	18.5	8.0±0.2	12.0±0.3
PC50EPC27-Z		1.067±.020	.850	.512±.012	.157±.004	.630±.008	.728	.315±.008	.472±.012
PC44EPC27N-Z	4	27.0±0.4	20.8	13.85±0.15	2.2±0.1	13.0±0.1	19.0	5.1±0.1	8.5±0.1
		1.063±.016	.819	.545±.006	.087±.004	.512±.004	.748	.201±.004	.335±.004
PC44EPC30-Z	1	30.1±0.5	23.6	15.0±0.3	4.0±0.1	17.5±0.2	20.0	8.0±0.2	13.0±0.3
PC50EPC30-Z		1.185±.020	.929	.591±.012	.157±.004	.689±.008	.787	.315±.008	.512±.012

Part No.	Effective parameter				Electrical characteristics		Core loss (W) max. 100kHz, 200mT, 100°C	Wt (g)	Bobbin item
	C <sub>1</sub> (mm <sup>-1</sup> )	A <sub>e</sub> (mm <sup>2</sup> )	ℓ <sub>e</sub> (mm)	V <sub>e</sub> (mm <sup>3</sup> )	AL-value (nH/N <sup>2</sup> ) <sup>*</sup> Without air gap	With air gap			
PC44EPC10-Z	1.89	9.39	17.8	167	1000±25%	40±7%	0.072	1.1	BEPC10-118GAFR
PC50EPC10-Z					660±25%	63±10%	0.025**		
PC44EPC13-Z	2.45	12.5	30.6	382	870±25%	40±4%	0.14	2.1	BEPC13-1110CPHFR BEPC13-1110GAFR
PC50EPC13-Z					560±25%	63±5%	0.039**		
PC44EPC17-Z	1.76	22.8	40.2	917	1150±25%	80±4%	0.35	4.5	BEPC17-1110CPHFR BEPC17-119GAFR
PC50EPC17-Z					740±25%	125±5%	0.1**		
PC44EPC19-Z	2.03	22.7	46.1	1050	940±25%	80±4%	0.4	5.3	BEPC19-1111CPHFR BEPC19-1110GAFR
PC50EPC19-Z					680±25%	125±5%	0.12**		
PC44EPC25-Z	1.28	46.4	59.2	2750	1560±25%	125±5%	1.11	13	BEPC25-1111CPHFR
PC50EPC25-Z					1080±25%	200±7%	0.32**		
PC44EPC25B-Z	1.39	33.3	46.2	1540	1560±25%	80±5%	0.65	11	BEPC25B-1111GAFR
PC50EPC25B-Z					1080±25%	125±7%	0.22**		
PC44EPC27-Z	1.34	54.6	73.1	4000	1540±25%	125±5%	1.56	18	BEPC27-1111CPHFR
PC50EPC27-Z					1030±25%	200±7%	0.46**		
PC44EPC27N-Z	1.70	33.0	55.9	1840	1400±25%	80±5% 125±7%	0.73	10	BEPC27N-1114CPHFR
PC44EPC30-Z	1.34	61.0	81.6	4980	1570±25%	125±5%	2.03	23	BEPC30-1112CPHFR
PC50EPC30-Z					1060±25%	200±7%	0.58**		

\* AL-value: 1kHz, 0.5mA, 100Ts

\*\* Core loss: 500kHz, 50mT, 100°C

# EPC BOBBINS



Lead through type

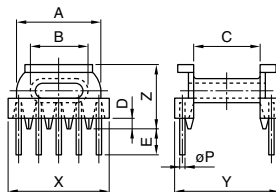

Drop in type

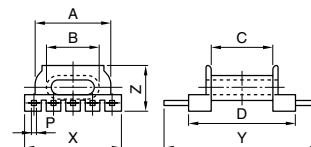

SMD type

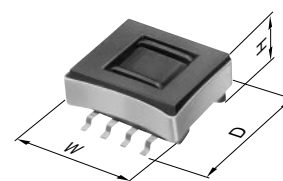
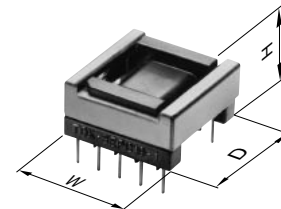
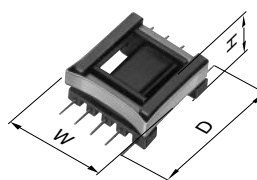
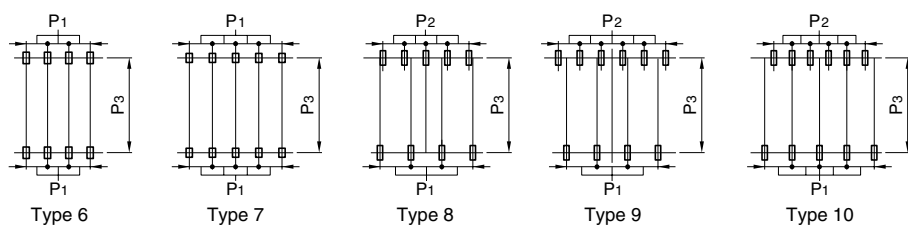
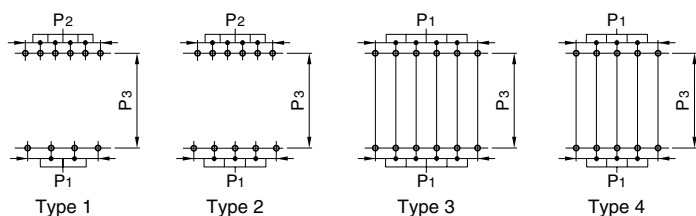
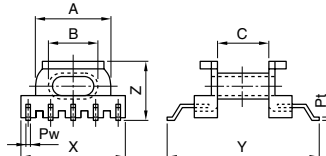

• All specifications are subject to change without notice.

## EPC BOBBINS

### Lead through type

Part No.	Dimensions in								
	mm inches								
	A	B	C	D	E	X	Y	Z	t*
<b>BEPC13-1110CPHFR</b>	10.23 .403	6.93 .273	6.88 .271	0.9 .035	2.5 .098	13.2 .520	13.2 .520	7.5 .295	0.5 .020
<b>BEPC17-1110CPHFR</b>	14.07 .554	9.88 .389	9.55 .376	2.5 .098	4.5 .177	17.2 .677	17.5 .689	11.9 .469	0.9 .035
<b>BEPC19-1111CPHFR</b>	15.58 .613	10.68 .420	12.04 .474	2.5 .098	4.5 .177	18.7 .736	19.0 .748	11.9 .469	0.9 .035
<b>BEPC25-1111CPHFR</b>	20.39 .803	13.73 .541	14.7 .579	3.0 .118	4.5 .177	25.0 .984	25.0 .984	16.0 .630	0.9 .035
<b>BEPC27-1111CPHFR</b>	21.33 .840	15.33 .604	20.7 .815	3.0 .118	4.5 .177	27.0 1.063	32.0 1.260	16.0 .630	0.8 .031
<b>BEPC27N-1114CPHFR</b>	20.5 .807	15.9 .623	14.1 .555	0.3 .012	3.5 .138	28.2 1.110	29.8 1.173	8.7 .343	0.9 .035
<b>BEPC30-1112CPHFR</b>	23.33 .919	17.33 .682	22.7 .894	3.0 .118	4.5 .177	30.0 1.181	35.0 1.378	16.0 .630	0.9 .035

Part No.	Dimensions in mm						Parameter		Wt (g)	Connecting pin pattern
	øP (mm)	P <sub>1</sub> (mm)	P <sub>2</sub> (mm)	P <sub>3</sub> (mm)	Terminal pins	W D (mm) H	Aw (mm <sup>2</sup> )	ℓ w (mm)		
<b>BEPC13-1110CPHFR</b>	∅0.49	2.5	—	10.5	10	13.9 14.8 7.7	11.2	23.0	0.57	Type 4
<b>BEPC17-1110CPHFR</b>	∅0.49	3.75	2.5	15.0	10	18.2 19.1 12.1	20.1	32.1	1.5	Type 1
<b>BEPC19-1111CPHFR</b>	∅0.49	3.75	2.5	16.25	11	20.0 21.5 12.1	29.3	34.4	1.6	Type 2
<b>BEPC25-1111CPHFR</b>	0.8	5.0	3.75	20.0	11	26.1 27.0 16.2	54.4	45.0	3.9	Type 2
<b>BEPC27-1111CPHFR</b>	0.8	5.0	3.75	27.5	11	28.1 34.0 16.2	62.1	47.2	4.7	Type 2
<b>BEPC27N-1114CPHFR</b>	0.8	3.75	—	25.0	14	29.0 36.5 9.0	32.4	43.7	3.1	Type 3
<b>BEPC30-1112CPHFR</b>	1.0	5.0	—	30.0	12	31.1 37.0 16.2	68.1	51.1	6.0	Type 3

UL Grade: 94V-0, Material: FR phenol, Pin material: Steel wire (Solder plated), Phosphor bronze (Solder plated) for BEPC25B-1111GAFR only. Maximum number of turns N that can be wound on bobbins, see section of "Maximum number of Turns on Bobbins".

\* Minimum thickness of bobbin inside which core is placed, including flanges.



## EPC BOBBINS

### SMD type

Part No.	Dimensions in								
	mm inches								
	A	B	C	D	E	X	Y	Z	t*
BEPC10-118GAFR	7.5 .295	5.95 .234	3.9 .154	—	—	10.8 .425	11.5 .453	4.85 .193	0.35 .014
BEPC13-1110GAFR	10.3 .406	6.93 .273	6.9 .272	—	—	14.0 .551	20.4 .803	7.02 .276	0.5 .020
BEPC17-119GAFR	14.1 .555	9.9 .390	9.6 .378	—	—	17.5 .689	23.0 .906	9.8 .386	0.8 .031
BEPC19-1110GAFR	15.4 .606	10.7 .421	12.0 .472	—	—	20.0 .787	25.0 .984	9.75 .384	0.8 .031
BEPC25B-1111GAFR	20.1 .791	15.7 .618	14.7 .579	—	—	25.0 .984	28.7 1.130	9.8 .386	0.8 .031

Part No.	Dimensions in mm						Parameter		Wt (g)	Connecting pin pattern
	Pt×Pw (mm)	P1 (mm)	P2 (mm)	P3 (mm)	Terminal pins	W D (mm) H	Aw (mm <sup>2</sup> )	ℓ w (mm)		
BEPC10-118GAFR	0.3×0.5	2.0	—	10.8	8	11.0 11.7 5.2	3.2	17.5	0.14	Type 6
BEPC13-1110GAFR	0.4×0.7	3.0	—	18.5	10	14.2 20.6 7.3	11.6	23.1	0.6	Type 7
BEPC17-119GAFR	0.4×0.7	5.0	3.5	21.8	9	18.2 23.2 9.9	20.1	32.1	1.1	Type 8
BEPC19-1110GAFR	0.4×0.7	5.0	3.5	23.8	10	20.2 25.2 9.9	28.2	34.4	1.3	Type 9
BEPC25B-1111GAFR	0.4×0.8	5.0	3.5	27.5	11	26.1 28.9 9.9	32.3	44.3	1.9	Type 10

UL Grade: 94V-0, Material: FR phenol, Pin material: Steel wire (Solder plated), Phosphor bronze (Solder plated) for BEPC25B-1111GAFR only.  
Maximum number of turns N that can be wound on bobbins, see section of "Maximum number of Turns on Bobbins".

\* Minimum thickness of bobbin inside which core is placed, including flanges.

### Drop in type

Part No.	Dimensions in								
	mm inches								
	A	B	C	D	E	X	Y	Z	t*
BEPC19-1110SAFR	15.6 .611	10.7 .413	12.0 .480	18.6 .835	—	20.0 .768	26.0 1.228	9.55 .337	0.8 .031
BEPC25B-1111SFR	20.1 .791	15.7 .618	14.7 .579	21.7 .854	—	25.0 .984	37.7 1.484	9.60 .378	0.8 .031

Part No.	Dimensions in mm						Parameter		Wt (g)	Connecting pin pattern
	Pt×Pw (mm)	P1 (mm)	P2 (mm)	P3 (mm)	Terminal pins	W D (mm) H	Aw (mm <sup>2</sup> )	ℓ w (mm)		
BEPC19-1110SAFR	0.4×0.7	5.0	3.5	22.3	10	20.2 26.2 9.8	28.2	34.4	1.3	Type 9
BEPC25B-1111SFR	0.4×0.7	5.0	3.5	29.7	11	26.0 37.9 9.5	30.9	50.5	2.1	Type 10

UL Grade: 94V-0, Material: FR phenol, Pin material: Steel wire (Solder plated), Phosphor bronze (Solder plated) for BEPC25B-1111GAFR only.  
Maximum number of turns N that can be wound on bobbins, see section of "Maximum number of Turns on Bobbins".

\* Minimum thickness of bobbin inside which core is placed, including flanges.

## EPC ACCESSORIES

Part No.	Dimensions in		C	D	E	t	Material
	A	B					
<b>FEPC-10-A</b>	10.8 .425	2.8 .110	1.5 .059	8.0 .315	0.8 .031	0.2 .008	Stainless steel
<b>FEPC-13-A</b>	13.7 .541	2.8 .110	2.9 .114	14.75 .581	2.65 .104	0.25 .010	Stainless steel
<b>FEPC-17-A</b>	18.1 .713	3.8 .150	2.9 .114	19.1 .752	3.0 .118	0.3 .012	Stainless steel
<b>FEPC-19-A</b>	19.9 .783	3.8 .150	2.9 .114	21.5 .846	3.0 .118	0.3 .012	Stainless steel
<b>FEPC-25-A</b>	26.0 1.024	5.6 .220	2.9 .114	27.0 1.063	3.0 .118	0.3 .012	Stainless steel
<b>FEPC-25B-A</b>	26.0 1.024	5.0 .197	2.9 .114	24.5 .965	3.0 .118	0.3 .012	Stainless steel
<b>FEPC-27-A</b>	28.0 1.102	5.6 .220	2.9 .114	34.0 1.339	3.0 .118	0.3 .012	Stainless steel
<b>FEPC-30-A</b>	31.0 1.220	5.6 .220	2.9 .114	37.0 1.457	3.0 .118	0.3 .012	Stainless steel

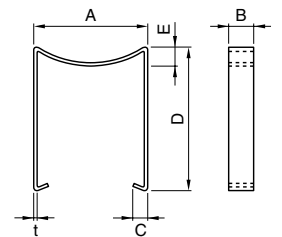

## EP CORES

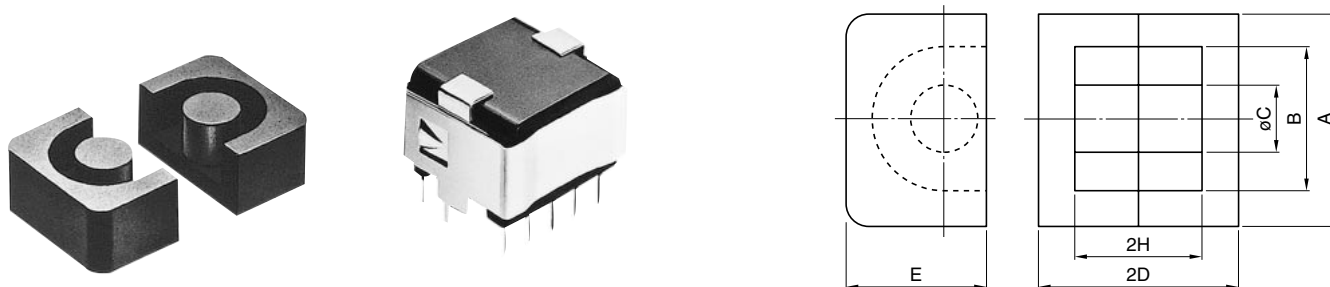

Part No.	Dimensions in						
	mm inches		A	B	øC	2D	E
<b>PC40EP7-Z</b>	9.2±0.2 .362±.008	7.4±0.2 .291±.008	3.3±0.1 .130±.004	7.4±0.1 .291±.004	6.35±0.15 .250±.006	5.2±0.2 .205±.008	
<b>PC40EP10-Z</b>	11.5±0.3	9.4±0.2	3.3±0.15	10.2±0.2	7.65±0.2	7.4±0.2	
<b>PC50EP10-Z</b>	.453±.012	.370±.008	.130±.006	.402±.008	.301±.008	.291±.008	
<b>PC40EP13-Z</b>	12.5±0.3	10.0±0.3	4.35±0.15	12.85±0.15	8.8±0.2	9.2±0.2	
<b>PC50EP13-Z</b>	.492±.012	.394±.012	.171±.006	.506±.006	.346±.008	.362±.008	
<b>PC40EP17-Z</b>	18.0±0.4 .709±.016	12.0±0.4 .472±.016	5.68±0.18 .224±.007	16.8±0.2 .661±.008	11.0±0.25 .433±.010	11.3±0.3 .445±.012	
<b>PC40EP20-Z</b>	24.0±0.5 .945±.020	16.5±0.4 .650±.016	8.75±0.25 .344±.010	21.4±0.2 .843±.008	14.95±0.35 .589±.014	14.3±0.3 .563±.012	

Part No.	Effective parameter				Electrical characteristics			Wt (g)	Bobbin item
	C <sub>1</sub> (mm <sup>-1</sup> )	A <sub>e</sub> (mm <sup>2</sup> )	l <sub>e</sub> (mm)	V <sub>e</sub> (mm <sup>3</sup> )	AL-value (nH/N <sup>2</sup> )*		Core loss (W) max. 100kHz, 200mT, 100°C		
					Without air gap	With air gap			
<b>PC40EP7-Z</b>	1.52	10.3	15.7	162	830 min.	63±3% 100±4%	0.065	1.4	BEP7-316DFR
<b>PC40EP10-Z</b>	1.70	11.3	19.2	217	800 min.	63±3% 100±4%	0.08	2.8	BEP10-318DFR
<b>PC50EP10-Z</b>					800±25%				
<b>PC40EP13-Z</b>	1.24	19.5	24.2	472	1170 min.	100±3% 160±3%	0.17	5.1	BEP13-3110DFR
<b>PC50EP13-Z</b>					1100±25%				
<b>PC40EP17-Z</b>	0.84	33.9	28.5	966	1840 min.	100±5% 250±7%	0.33	12	BEP17-318DFR
<b>PC40EP20-Z</b>	0.508	78	39.8	3120	3200 min.	100±5% 250±7%	1.1	28	BEP20-8110DFR

\* AL-value: 1kHz, 0.5mA, 100T<sub>s</sub>

\*\* Core loss: 500kHz, 50mT, 100°C

## EP BOBBINS

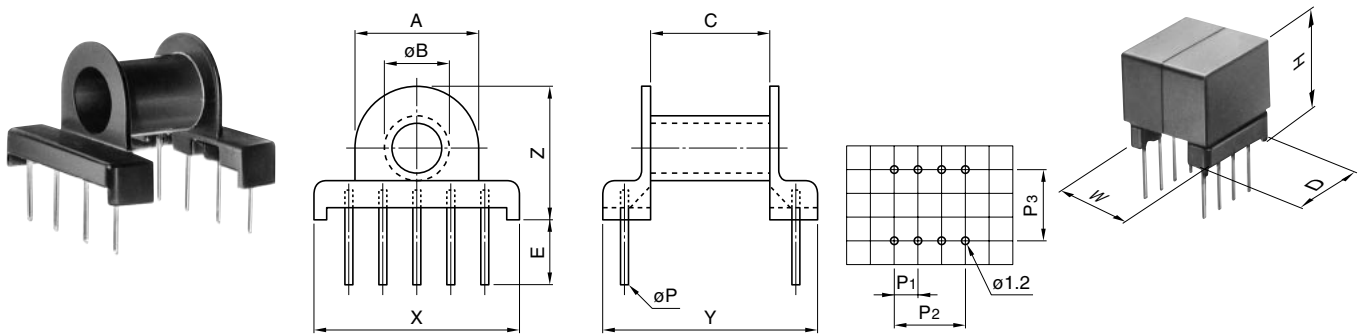

Part No.	Dimensions in		C	E	X	Y	Z	t*
	mm	inches						
	A	øB						
<b>BEP7-316DFR</b>	7.0 .276	4.5 .177	3.1 .122	3.25 .128	9.2 .362	7.4 .291	8.25 .325	0.25 .010
<b>BEP10-318DFR</b>	8.8 .346	4.8 .189	5.6 .220	5.2 .205	11.0 .433	11.0 .433	10.2 .402	0.40 .016
<b>BEP13-3110DFR</b>	9.6 .378	5.7 .224	7.7 .303	5.3 .209	13.2 .520	13.5 .531	10.8 .425	0.38 .015
<b>BEP17-318DFR</b>	11.4 .449	7.2 .283	9.4 .370	5.0 .197	19.0 .748	19.0 .748	13.2 .520	0.35 .014
<b>BEP20-8110DFR</b>	15.9 .626	10.2 .402	12.4 .488	5.0 .197	24.7 .972	21.5 .846	16.6 .654	0.43 .017

Part No.	Dimensions in mm				Terminal pins	W D (mm) H	Parameter		Wt (g)	Accessory item
	øP (mm)	P1 (mm)	P2 (mm)	P3 (mm)			Aw (mm <sup>2</sup> )	ℓ w (mm)		
<b>BEP7-316DFR</b>	0.6	2.5	5.0	5.0	6	9.4 7.5 9.6	3.85	18.1	0.3	FEP-7-C
<b>BEP10-318DFR</b>	0.6	2.5	7.5	7.5	8	11.8 11.2 11.8	11.7	21.7	0.65	FEP-10-C
<b>BEP13-3110DFR</b>	0.6	2.5	10.0	10.0	10	13.4 13.7 12.7	16.6	23.9	0.74	FEP-13-C
<b>BEP17-318DFR</b>	0.6	5.0	15.0	15.0	8	19.25 19.25 15.7	19.0	29.1	1.3	FEP-17-C
<b>BEP20-8110DFR</b>	0.6	5.0	20.0	17.5	10	25.0 21.8 19.6	33.2	40.8	1.8	FEP-20-C

UL Grade: 94V-0, Material: FR phenol, Pin material: Phosphor bronze (Solder plated)

Maximum number of turns N that can be wound on bobbins, see section of "Maximum number of Turns on Bobbins".

\* Minimum thickness of bobbin inside which core is placed, including flanges

# RM SERIES

## Cores

RM4 to RM14

## Bobbins

BRM4 to BRM14

## Accessories

FRM4 to FRM14



### Ordering Code System

#### Cores

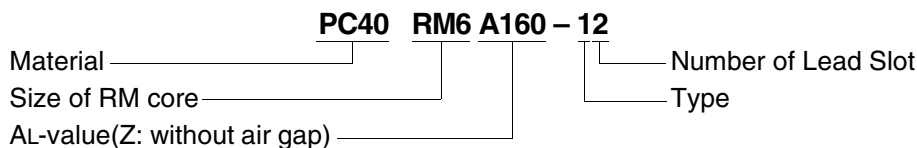

#### Bobbins

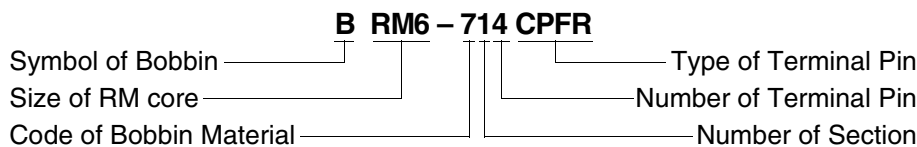

#### Accessories

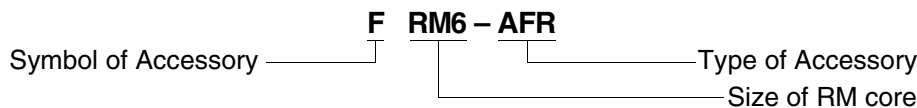

## RM CORES

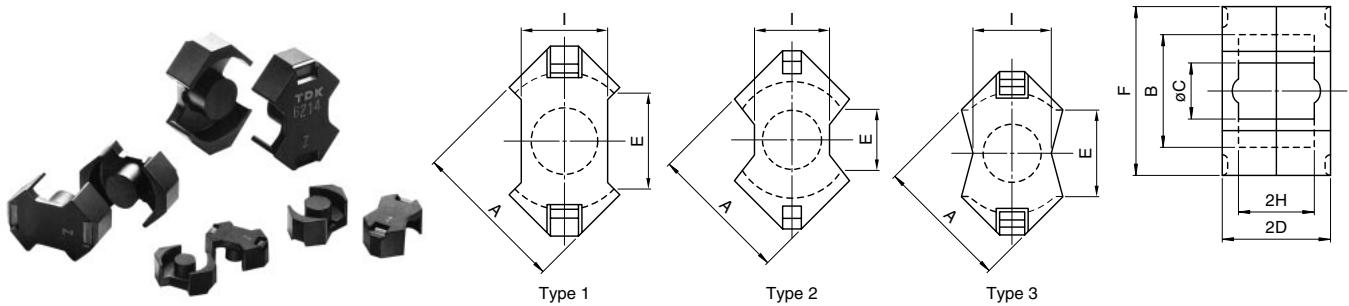

Part No.	Type	Dimensions in							
		A	B	øC	2D	E	F	2H	I
PC40RM4Z-12	1	9.63±0.18	8.15±0.2	3.8±0.1	10.4±0.1	5.8	10.8±0.2	7.2±0.2	4.45±0.15
PC50RM4Z-12		.379±.007	.321±.008	.150±.004	.409±.004	.228	.425±.008	.283±.008	.175±.006
PC40RM5Z-12	1	12.05±0.25	10.4±0.2	4.8±0.1	10.4±0.1	6.0	14.3±0.3	6.5±0.2	6.6±0.2
PC50RM5Z-12		.474±.010	.409±.008	.189±.004	.409±.004	.236	.563±.012	.256±.008	.260±.008
PC40RM6Z-12	3	14.4±0.3	12.65±0.25	6.3±0.1	12.4±0.1	8.4	17.6±0.3	8.2±0.2	8.0±0.2
PC50RM6Z-12		.567±.012	.498±.010	.248±.004	.488±.004	.331	.693±.012	.323±.008	.315±.008
PC40RM8Z-12	2	19.35±0.35	17.3±0.3	8.4±0.15	16.4±0.1	9.8	22.75±0.45	11.0±0.2	10.8±0.2
PC40RM10Z-12		.762±.014	.681±.012	.331±.006	.646±.004	.386	.896±.018	.433±.008	.425±.008
PC40RM10Z-12	2	24.15±0.55	21.65±0.45	10.7±0.2	18.6±0.1	11.3	27.85±0.65	12.7±0.3	13.25±0.25
PC40RM12Z-12		.951±.022	.852±.018	.421±.008	.732±.004	.445	1.096±.026	.500±.012	.522±.010
PC40RM12Z-12	2	29.25±0.55	25.5±0.5	12.6±0.2	23.5±0.1	12.9	36.75±0.65	17.1±0.3	16.0±0.3
PC40RM14Z-12		1.152±.022	1.004±.020	.496±.008	.925±.004	.508	1.447±.026	.673±.012	.630±.012
PC40RM14Z-12	1	34.2±0.5	29.5±0.5	14.75±0.25	28.8±0.2	17.0	41.6±0.6	21.1±0.3	18.7±0.3
		1.346±.020	1.161±.020	.581±.010	1.134±.008	.669	1.638±.024	.831±.012	.736±.012

Part No.	Effective parameter				Electrical characteristics			Wt (g)	Bobbin item
	C <sub>1</sub> (mm <sup>-1</sup> )	A <sub>e</sub> (mm <sup>2</sup> )	l <sub>e</sub> (mm)	V <sub>e</sub> (mm <sup>3</sup> )	AL-value (nH/N <sup>2</sup> )*		Core loss (W) max. 100kHz, 200mT, 100°C		
					Without air gap	With air gap			
PC40RM4Z-12	1.62	14.0	22.7	318	680 min.	63±3%	0.12	1.7	BRM4-714SDFR
PC50RM4Z-12					960±25%	100±3%			
PC40RM5Z-12	0.940	23.7	22.4	530	1250 min.	63±3%	0.18	3.0	BRM5-714CPFR
PC50RM5Z-12					1340±25%	100±3%			
PC40RM6Z-12	0.781	36.6	28.6	1050	2450±25%	100±3%	0.41	5.5	BRM6-714CPFR
PC50RM6Z-12					1700±25%	160±3%			
PC40RM8Z-12	0.594	64.0	38.0	2430	1950 min.	100±3%	0.97	13	BRM8-718CPFR
						160±3%			
PC40RM10Z-12	0.450	98.0	44.0	4310	4850±25%	160±3%	1.8	23	BRM10-7110SDNFR
						250±3%			
PC40RM12Z-12	0.406	140	56.9	7970	4150 min.	160±3%	3.3	42	BRM12-7111CPFR
						250±3%			
PC40RM14Z-12	0.393	178	70.0	12500	4600 min.	160±3%	4.75	70	BRM14-7110CPFR
						250±3%			

\* AL-value: 1kHz, 0.5mA, 100Ts

\*\* Core loss: 500kHz, 50mT, 100°C

## RM BOBBINS

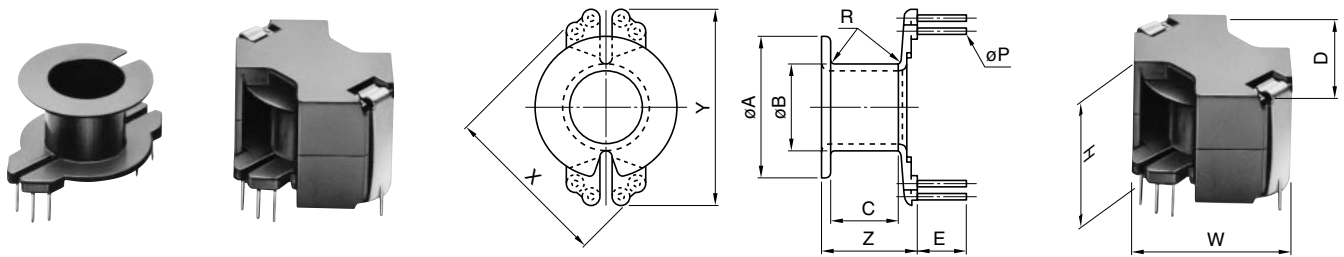

Part No.	Dimensions in		C	E	X	Y	Z	t*
	mm	inches						
<b>BRM4-716SDFR</b>	7.75 .305	4.85 .191	5.55 .219	4.40 .207	9.52 .375	4.3 .169	7.55 .297	0.25 .010
<b>BRM5-716CPFR</b>	10.00 .394	5.90 .232	4.88 .192	5.00 .197	12.5 .492	16.2 .638	7.9 .311	0.35 .014
<b>BRM6-716CPFR</b>	12.20 .480	7.35 .289	6.35 .250	4.50 .177	15.0 .591	20.0 .787	9.6 .378	0.3 .012
<b>BRM8-718CPFR</b>	16.80 .661	9.85 .388	9.05 .356	5.60 .220	20.24 .797	24.6 .967	12.7 .500	0.425 .017
<b>BRM10-7112SDFR</b>	20.90 .823	12.40 .488	10.60 .417	4.78 .188	22.5 .886	27.75 1.093	13.40 .528	0.5 .020
<b>BRM12-7112CPFR</b>	24.60 .969	14.40 .567	14.70 .579	6.35 .250	30.0 1.181	38.00 1.496	18.9 .744	0.55 .022
<b>BRM14-7112CPFR</b>	28.70 1.130	16.70 .657	18.55 .730	6.35 .250	35.56 1.400	41.90 1.650	22.9 .902	0.6 .024

Part No.	Dimensions in mm			Parameter		Wt (g)	Other bobbins' item	Accessory item
	øP (mm)	Terminal pins	W D (mm) H	Aw (mm <sup>2</sup> )	ø w (mm)			
<b>BRM4-716SDFR</b>	ø0.45	6	10.0 10.0 10.5	8.05	19.8	0.23	BRM4-714SDFR	FRM4-AFR
<b>BRM5-716CPFR</b>	0.50	6	12.5 12.5 10.5	10.1	25	0.26	BRM5-714CPFR	FRM5-AFR
<b>BRM6-716CPFR</b>	0.60	6	15.0 15.0 12.5	15.5	31	0.43	BRM6-714CPFR	FRM6-AFR
<b>BRM8-718CPFR</b>	0.60	8	20.0 20.0 16.5	31.0	42	1.00	BRM8-7112CPFR	FRM8-AFR
<b>BRM10-7112SDFR</b>	ø0.51	12	24.7 24.7 18.7	45.7	53	1.6	BRM10-7110SDNFR	FRM10-AFR
<b>BRM12-7112CPFR</b>	0.80	12	30.0 30.0 23.6	75.5	55	2.7	BRM12-7111CPFR	FRM12-AFR
<b>BRM14-7112CPFR</b>	0.80	12	35.6 35.6 29.0	113	72	3.8	BRM14-7110CPFR	FRM14-AFR

UL Grade: 94V-0, Material: FR phenol

Pin material: CPFR type is steel wire (solder plated)

SDFR and SDNFR types are phosphor bronz wire (solder plated)

Maximum number of turns N that can be wound on bobbins, see section of "Maximum number of Turns on Bobbins".

\* Minimum thickness of bobbin inside which core is placed, including flanges.

### Connecting Pin Patterns (2.54mm/0.1 inch grids) View in mounting direction

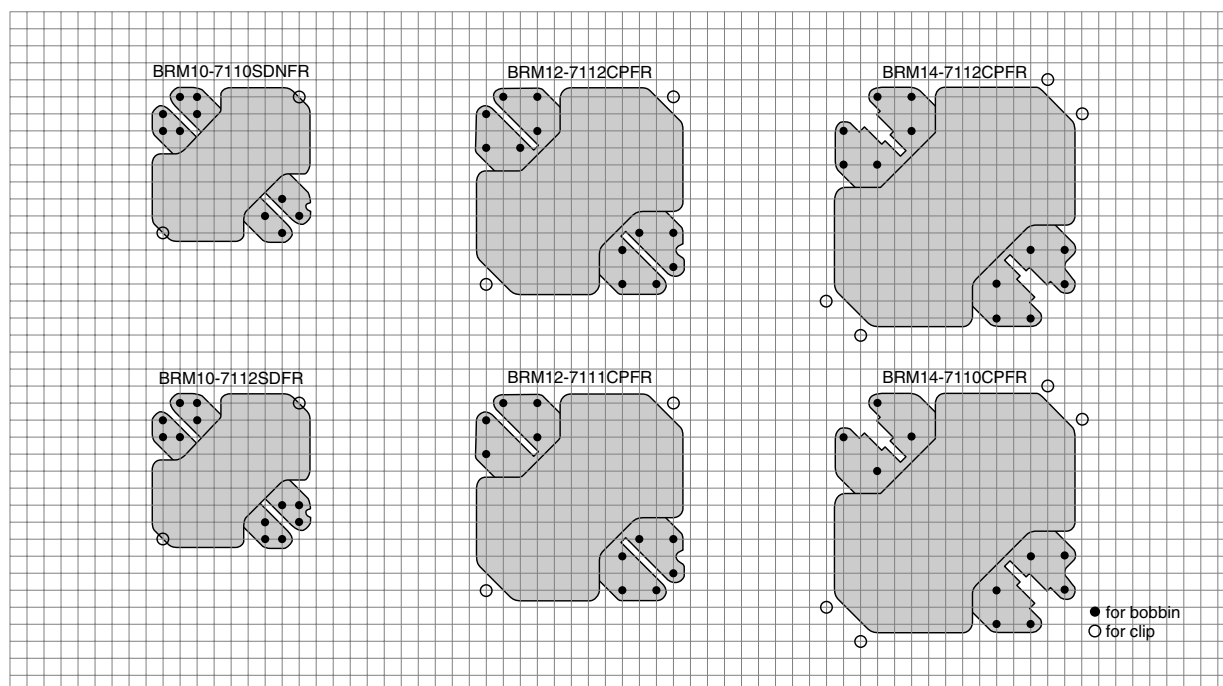
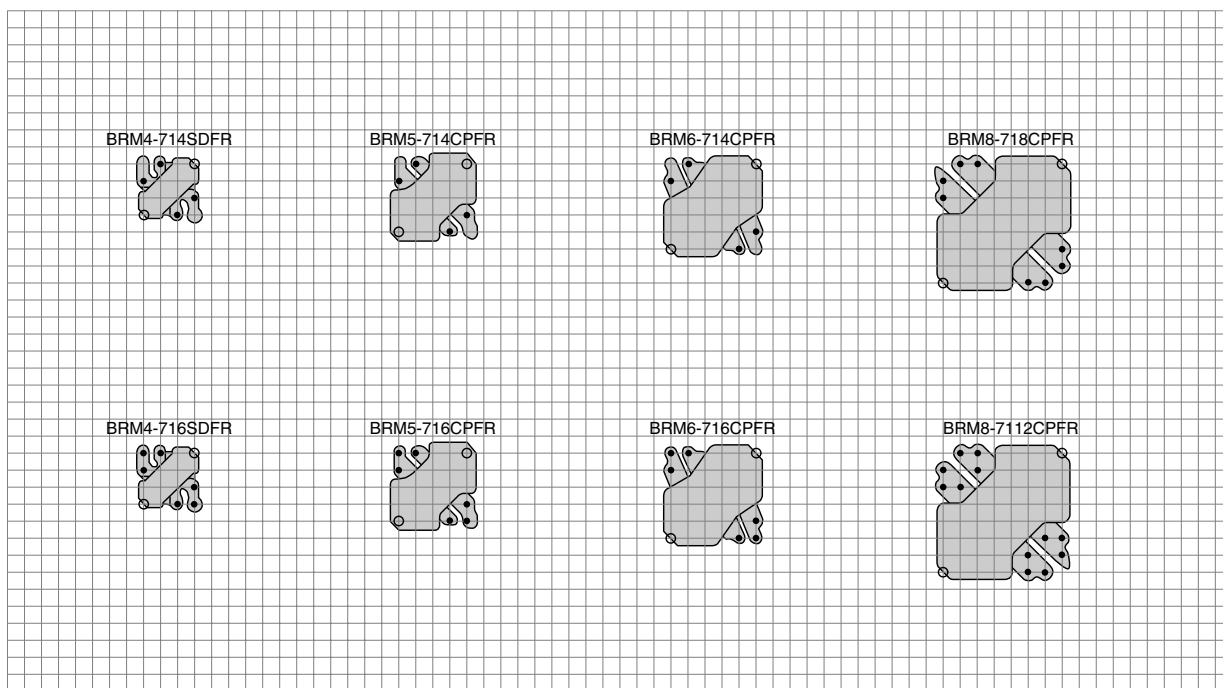



# SMD CORES

## Cores

- EE5, EE8.9/8
- ER9.5/5, ER11/3.9, ER11/5
- ER14.5/6
- EEM12.7/13.7

## Bobbins

- BE5, BE8.9/8
- BER9.5/5, BER11/3.9, BER11/5
- BER14.5/6
- BEM12.7

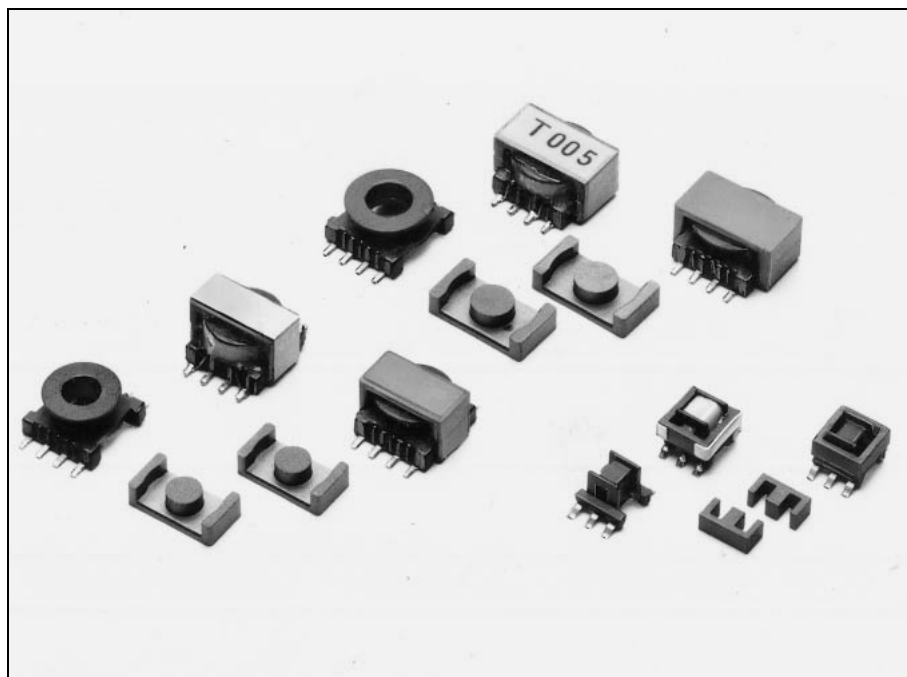

## Ordering Code System

### Cores

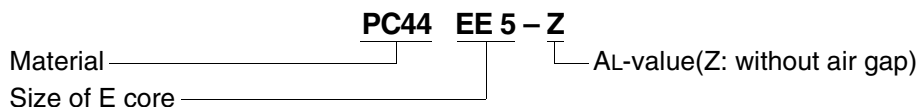

### Bobbins

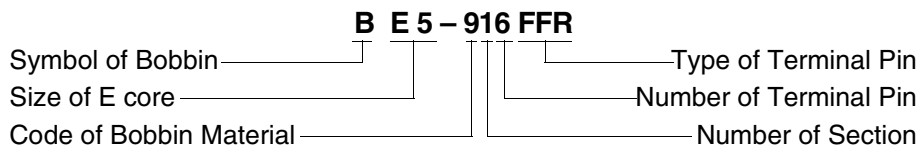

• All specifications are subject to change without notice.

## EE, ER AND EEM CORES

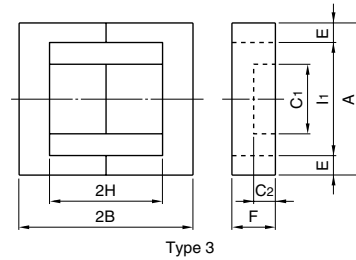
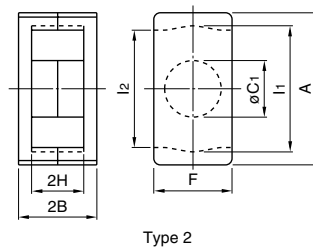
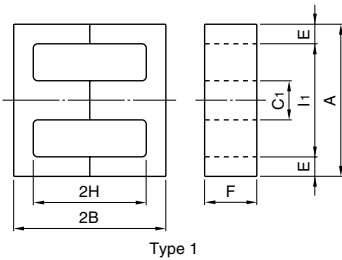
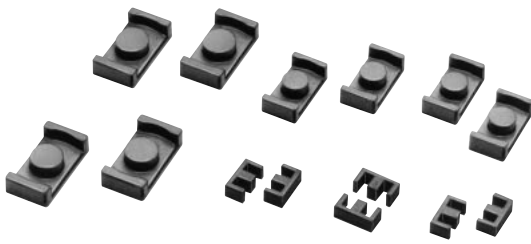

Part No.	Type	Dimensions in $\frac{\text{mm}}{\text{inches}}$								
		A	2B	C1	C2	E	F	2H	l1	l2
PC44EE5-Z	1	5.25±0.05 .207±.002	5.3±0.1 .209±.004	1.35±0.05 .053±.002		0.70±0.05 .028±.002	1.95±0.05 .077±.002	4.0 .157	3.85 .152	
PC44EE8.9/8-Z	1	8.86±0.20 .349±.008	8.0±0.3 .315±.012	1.90±0.12 .075±.005		1.91±0.20 .075±.008	1.90±0.12 .075±.008	4.5±0.3 .177±.012	5.08 min. .200 min.	
PC44ER9.5/5-Z PC50ER9.5/5-Z	2	9.35±0.15 .368±.006	4.9±0.1 .193±.004	3.4±0.1 .134±.004			4.9±0.1 .193±.004	3.35±0.15 .132±.004	7.63±0.13 .300±.005	7.0 min. .276 min.
PC44ER11/3.9-Z PC50ER11/3.9-Z	2	10.83±0.18 .426±.007	3.85±0.10 .152±.004	4.13±0.13 .163±.005			5.9±0.1 .232±.004	2.10±0.15 .083±.006	8.85±0.15 .348±.006	7.9 min. .311 min.
PC44ER11/5-Z PC50ER11/5-Z	2	10.83±0.18 .426±.007	4.9±0.1 .193±.004	4.13±0.13 .163±.005			5.9±0.1 .232±.004	3.15±0.15 .124±.006	8.85±0.15 .348±.006	7.9 min. .311 min.
PC44ER14.5/6-Z PC50ER14.5/6-Z	2	14.5±0.2 .571±.008	5.9±0.1 .232±.004	4.7±0.1 .185±.004			6.7±0.1 .264±.004	3.3±0.2 .130±.008	11.8±0.2 .465±.008	11.8±0.2 .465±.008
PC44EEM12.7/13.7-Z PC50EEM12.7/13.7-Z	3	12.75±0.25 .502±.010	13.7±0.3 .539±.012	6.0±0.1 .236±.004	1.85±0.10 .073±.004	1.7±0.1 .067±.004	3.30±0.15 .130±.006	9.1±0.3 .358±.012	9.0 min. .354 min.	

Part No.	Effective parameter				Electrical characteristics		Wt (g)	Bobbin item
	C1 (mm <sup>-1</sup> )	Ae (mm <sup>2</sup> )	ℓe (mm)	Ve (mm <sup>3</sup> )	AL-value (nH/N <sup>2</sup> ) <sup>*</sup> Without air gap	With air gap		
PC44EE5-Z	4.72	2.67	12.6	33.6	200 min.		0.2	BE5-916FFR
PC44EE8.9/8-Z	3.15	4.96	15.6	77.4	480±25%		0.6	BE8.9/8-118GFR
PC44ER9.5/5-Z PC50ER9.5/5-Z	1.68	8.47	14.2	120	610 min. 750±25%	63±5% 100±7%	0.6	BER9.5/5-118GAFR
PC44ER11/3.9-Z PC50ER11/3.9-Z	1.08	11.7	12.6	147	1040 min. 1100±25%	63±5% 100±7%	0.8	BER11/3.9-1110GAFR
PC44ER11/5-Z PC50ER11/5-Z	1.24	11.9	14.7	175	870 min. 960±25%	63±5% 100±7%	1.0	BER11/5-1110GAFR
PC44ER14.5/6-Z PC50ER14.5/6-Z	1.08	17.6	19.0	334	1280 min. 1150±25%	100±5% 160±7%	1.8	BER14.5/6-1110GAFR
PC44EEM12.7/13.7-Z PC50EEM12.7/13.7-Z	2.28	12.0	27.3	328	820±25% 580±25%	40±5% 63±7%	1.9	BEM12.7-118GAFR

\* AL-value: 1kHz, 0.5mA, 100Ts

# EE, ER AND EEM BOBBINS

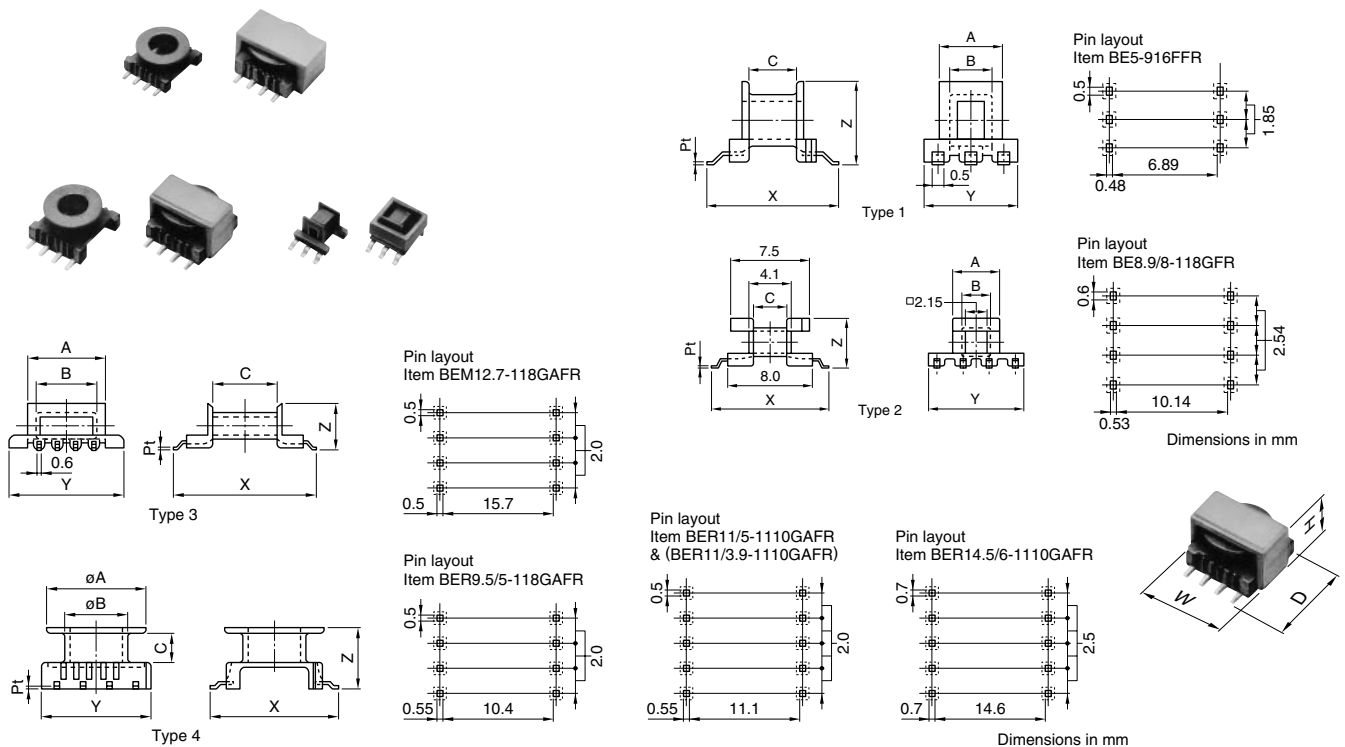

Part No.	Type	Dimensions in		C	X	Y	Z	t*
		mm	inches					
BE5-916FFR BE5-926F1FR	1	3.50 .138	2.30 .091	2.70 .106	7.85 .309	5.20 .205	4.70 .185	0.35 .014
BE8.9/8-118GFR	2	4.50 .177	2.70 .106	3.10 .122	11.20 .441	9.20 .362	4.78 .188	0.225 .009
BEM12.7-118GAFR	3	8.90 .350	6.90 .272	7.50 .295	16.70 .657	12.80 .504	4.90 .193	0.30 .012
BER9.5/5-118GAFR	4	7.30 .287	4.45 .175	2.15 .085	11.50 .453	8.2 .323	4.45 .175	0.35 .014
BER11/3.9-1110GAFR	4	8.50 .335	5.20 .205	1.05 .041	12.45 .490	10.50 .413	3.55 .140	0.35 .014
BER11/5-1110GAFR**	4	8.50 .335	5.20 .205	1.95 .077	12.20 .480	10.50 .413	4.70 .185	0.35 .014
BER14.5/6-1110GAFR	4	11.40 .449	5.90 .232	2.00 .079	16.00 .630	14.00 .551	5.85 .230	0.30 .012

Part No.	Dimensions in mm			Parameter		Material	Wt (g)	Accessory item
	Pt×Pw (mm)	Terminal pins	W D (mm) H	Aw (mm <sup>2</sup> )	∅ w (mm)			
BE5-916FFR BE5-926F1FR	0.2×0.5	6	5.7 7.8 4.8	1.62	12.4	Diallyl Phtalate	0.03 0.07	FE-5-A
BE8.9/8-118GFR	0.2×0.6	8	9.3 11.3 4.8	2.79	14.4	FR Phenol	0.17	—
BEM12.7-118GAFR	0.3×0.5	8	13.6 16.8 5.0	7.5	22.4	FR Phenol	0.31	FEM12.7/13.7-A
BER9.5/5-118GAFR	0.3×0.5	8	9.9 11.7 5.9	3.06	18.5	FR Phenol	0.16	FER9.5/5-A
BER11/3.9-1110GAFR	0.3×0.5	10	11.0 12.6 4.7	1.73	21.5	FR Phenol	0.21	FER11/3.9-A
BER11/5-1110GAFR**	0.3×0.5	10	11.5 12.3 6.4	3.22	21.5	FR Phenol	0.21	FER11/5-A
BER14.5/6-1110GAFR	0.4×0.7	10	15.1 16.2 7.3	5.5	27.2	FR Phenol	0.55	FER14.5/6-A

UL Grade: 94V-0, Material of pins: F, G types are Phosphor bronze wire (Solder plated), GA type is Steel wire (Solder plated). Maximum number of turns N that can be wound on bobbins, see section of "Maximum number of Turns on Bobbins".

\* Minimum thickness of bobbin.

\*\* 8-pin is available (Part No. BER11/5-118GAFR).

# ET, UU AND FT SERIES

## Cores

ET20 to 35

UU10.1 to UU19.7B

FT20.6

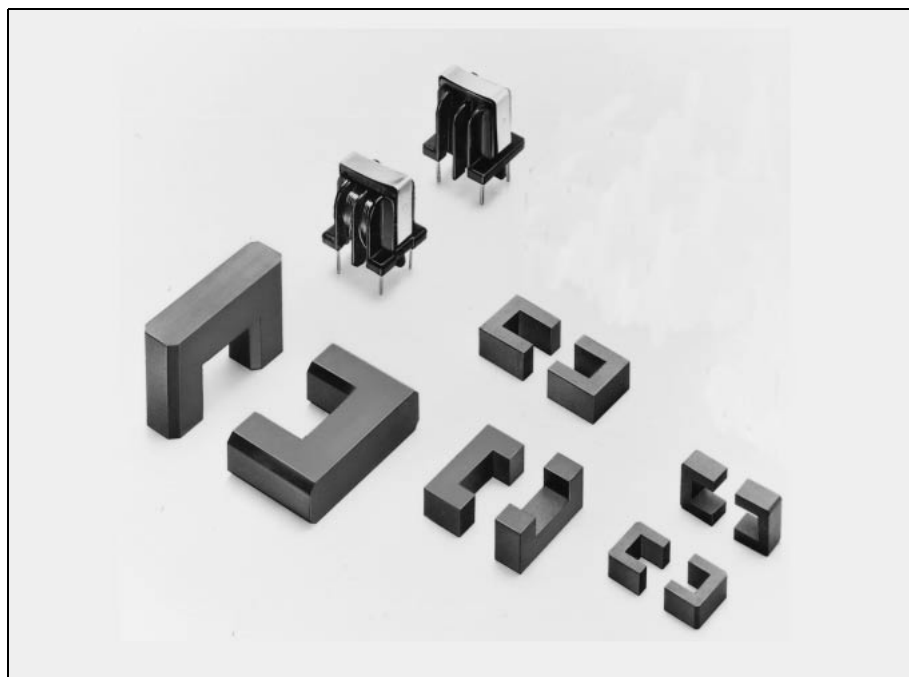

## Ordering Code System

### Cores

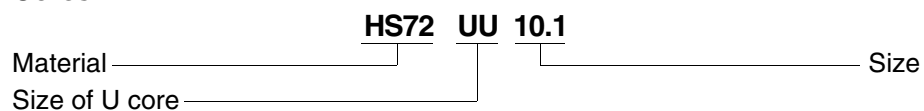

## ET AND UU CORES

### ET Cores

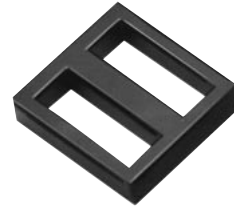
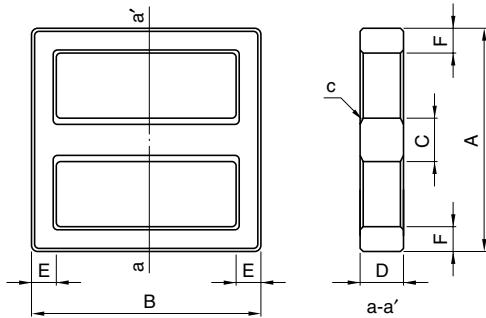

Part No.	AL-value* (nH/N <sup>2</sup> )	Dimensions in mm inches						Ae (mm <sup>2</sup> )	ℓe (mm)
		A	B	C	D	E	F		
HS72ET20	3100 <sup>+40%</sup> <sub>-25%</sub>	20.1±0.4 .791±.016	20.1±0.4 .791±.016	4.0±0.2 .157±.008	4.4±0.2 .173±.008	2.00±0.15 .079±.006	2.00±0.15 .079±.006	17.6	50.6
HS72ET24	2600 <sup>+40%</sup> <sub>-25%</sub>	24.2±0.5 .953±.020	24.2±0.5 .953±.020	4.0±0.2 .157±.008	4.0±0.3 .157±.012	2.40±0.15 .094±.006	2.40±0.15 .094±.006	17.8	61.0
HS72ET28	3550 <sup>+40%</sup> <sub>-25%</sub>	28.45±0.55 1.120±.022	28.45±0.55 1.120±.022	5.0±0.2 .197±.008	5.0±0.3 .197±.012	2.90±0.15 .114±.006	2.90±0.15 .114±.006	27.4	71.4
HS10ET28	4835±30%	28.45±0.55 1.120±.022	28.45±0.55 1.120±.022	5.0±0.2 .197±.008	5.0±0.3 .197±.012	2.90±0.15 .114±.006	2.90±0.15 .114±.006	27.4	71.4
HS72ET35	6000 <sup>+40%</sup> <sub>-25%</sub>	35.3±0.6 1.390±.024	35.3±0.6 1.390±.024	7.5±0.3 .295±.012	7.5±0.3 .295±.012	4.0±0.2 .157±.008	4.0±0.2 .157±.008	58.6	86.7

\* AL-value: 1kHz, 0.25A/m, 10Ts

### UU Cores

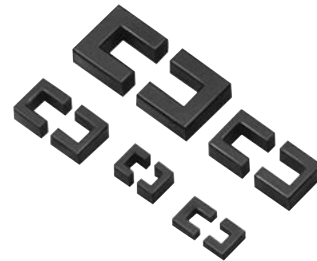
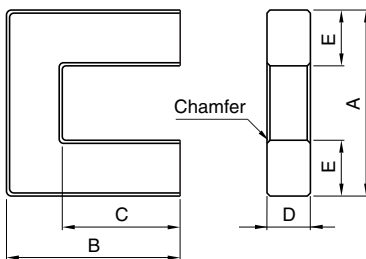

Part No.	AL-value* (nH/N <sup>2</sup> )	Dimensions in mm inches					Ae (mm <sup>2</sup> )	ℓe (mm)
		A	B	C	D	E		
HS72UU10.1	1005±25%	10.1±0.3 .398±.012	7.5±0.25 .295±.010	4.5±0.25 .177±.010	2.9±0.15 .114±.006	2.95±0.15 .116±.006	8.6	35.7
HS72UU10.5	1500±25%	10.5±0.3 .413±.012	7.80±0.2 .307±.008	5.25±0.3 .207±.012	5.00±0.20 .197±.008	2.5±0.20 .098±.008	12.5	40.3
HS72UU15.7	2600±25%	15.7±0.4 .618±.016	9.70±0.25 .382±.010	6.00±0.30 .236±.012	6.00±0.30 .236±.012	4.50 .177	24.8	50.0
HS72UU19.7B	2650±25%	19.7±0.4 .776±.016	17.7±0.3 .697±.012	11.7±0.3 .461±.012	6.00±0.30 .236±.012	6.00±0.30 .236±.012	35.7	81.1

\* AL-value: 1kHz, 0.25A/m, 10Ts

## FT CORES

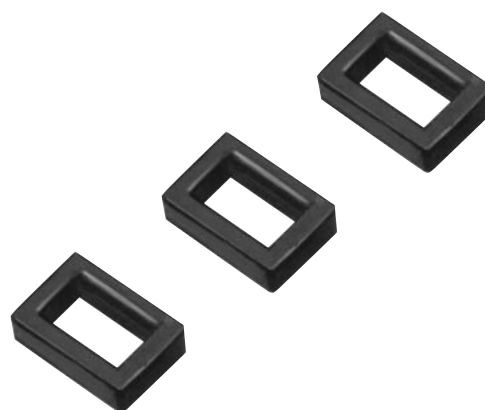
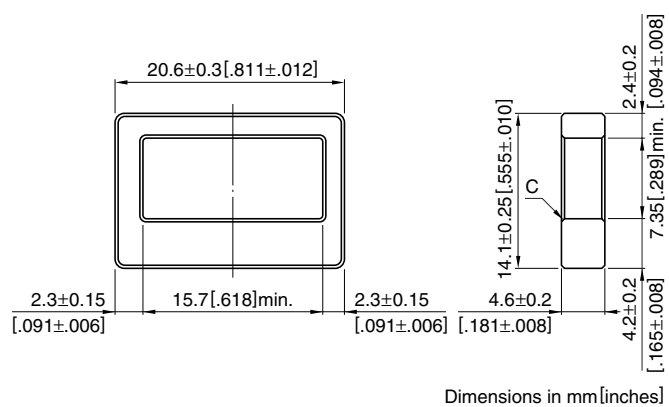

Part No.	AL-value* (nH/N <sup>2</sup> )	Ae (mm <sup>2</sup> )	ℓ e (mm)
HS72FT20.6	2200 <sup>+40%</sup> <sub>-30%</sub>	12.1	52.9
HS10FT20.6	2690±30%	12.1	52.9

\* AL-value: 1kHz, 0.25A/m, 10Ts

# TOROIDAL CORES

TDK's toroidal cores are available in a number of sizes. Therefore, by selecting the ferrite material which corresponds to the application, it is possible to design stable transformers, inductors, etc. to cover a wide band range.

### FEATURES

- Selection of core material to correspond to the application is possible as a result of standard ferrite materials with  $\mu=5500$  to 10000.
- Epoxy and paraxyllylene insulation coating is available.

### APPLICATIONS

Choke coils, filters, current sensors, EMI/RFI filters, balun transformers.

### T14 to T44.5

Material: HS52, HS72, HS10



Ordering Code System

### Cores

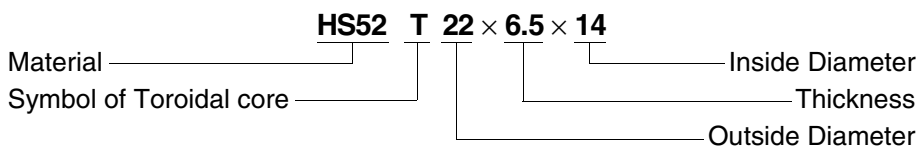

• All specifications are subject to change without notice.

## T CORES

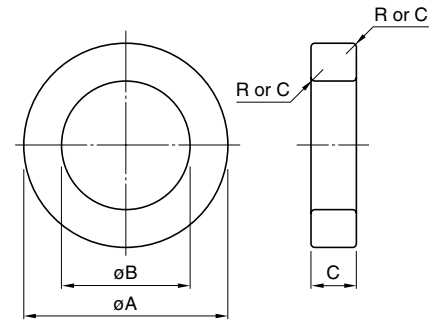

Part No.	JIS C 2569	Dimensions in $\frac{\text{mm}}{\text{inches}}$			Effective parameter	
		$\phi A$	$\phi B$	C	$C_1$ ( $\text{mm}^{-1}$ )	$A_e$ ( $\text{mm}^2$ )
<b>T14×7×8</b>		14.0±0.3 .551±.012	8.0±0.3 .315±.012	7.0±0.3 .276±.012	1.60	20.5
<b>T18×10×10</b>	FOR-18-10-10	18.0±0.3 .709±.012	10.0±0.3 .394±.012	10.0±0.3 .394±.012	1.07	38.9
<b>T16×8×12</b>		16.0±0.3 .630±.012	12.0±0.3 .472±.012	8.0±0.3 .315±.012	2.73	15.9
<b>T20×10×12</b>	FOR-20-10-12	20.0±0.4 .787±.016	12.0±0.4 .472±.016	10.0±0.3 .394±.012	1.23	39.1
<b>T22×6.5×14</b>		22.0±0.4 .866±.016	14.0±0.4 .551±.016	6.5±0.3 .256±.012	2.14	25.6
<b>T25×13×15</b>		25.0±0.4 .984±.016	15.0±0.4 .591±.016	13.0±0.3 .512±.012	0.946	63.6
<b>T28×13×16</b>	FOR-28-13-16	28.0±0.4 1.102±.016	16.0±0.4 .630±.016	13.0±0.3 .512±.012	0.864	76.0
<b>T31×8×19</b>		31.0±0.5 1.220±.020	19.0±0.5 .748±.020	8.0±0.3 .315±.012	1.60	47.1
<b>T38×14×22</b>		38.0±0.5 1.496±.020	22.0±0.5 .866±.020	14.0±0.4 .551±.016	0.821	109
<b>T44.5×13×30</b>	FOR-45-13-30	44.5±0.5 1.752±.020	30.0±0.5 1.181±.020	13.0±0.4 .512±.016	1.23	93

Part No.	Effective parameter			AL-value (nH/N <sup>2</sup> )			Wt (g)
	$\phi e$ (mm)	$V_e$ (mm <sup>3</sup> )	R or C	Material			
				HS52*	HS72**	HS10***	
<b>T14×7×8</b>	32.8	671	C0.5	3800±25%	5100±25%	6800±30%	3.4
<b>T18×10×10</b>	41.5	1610	C0.5	6400±25%	8800±25%	10150±30%	8.3
<b>T16×8×12</b>	43.4	689	C0.3	2500±25%	3400±25%	4500±30%	3.4
<b>T20×10×12</b>	48.1	1880	C0.5	5600±25%	7600±25%	10000±30%	9.5
<b>T22×6.5×14</b>	54.7	1400	C0.5	3200±25%	4400±25%	5750±30%	6.9
<b>T25×13×15</b>	60.2	3830	C1.0	7300±25%	9900±25%	13000±30%	19
<b>T28×13×16</b>	65.6	4990	C0.5	8000±25%	10700±25%	14200±30%	26
<b>T31×8×19</b>	75.5	3550	C1.0	4300±25%	5800±25%	7700±30%	17
<b>T38×14×22</b>	89.7	9800	C1.0	8400±25%	10700±25%	—	50
<b>T44.5×13×30</b>	114	10600	C0.5	5600±25%	7100±25%	—	53

\* AL-value: 100kHz, 100mV, 10Ts

\*\* AL-value: 100kHz, 10mV, 5Ts

\*\*\* AL-value: 10kHz, 10mV, 10Ts

Can be coated with epoxy. If epoxy-coated products are desired, please suffix E to part No. when ordering.

Ex. HS52 T22 × 6.5 × 12E

Outer diameter( $\phi A$ )

10mm min.(T10): Epoxy coating

8mm max.(T8): Paraxylolene coating

\* Dielectric breakdown voltage 1000Vd.c. min.

• All specifications are subject to change without notice.