

Interference coupling mechanisms

5.1 Source and victim

Situations in which the question of electromagnetic compatibility arises invariably have two complementary aspects. Any such situation must have a source of interference emissions and a victim which is susceptible to this interference. If either of these is not present, there is no EMC problem. If both source and victim are within the same piece of equipment we have an "intra-system" EMC situation; if they are two different items, such as a computer monitor and a radio receiver, it is said to be an "inter-system" situation. The standards which were discussed in Chapter 2 were all related to controlling inter-system EMC. The same equipment may be a source in one situation and a victim in another.

Knowledge of how the source emissions are coupled to the victim is essential, since a reduction in the coupling factor is often the only way to reduce interference effects, if a product is to continue to meet its performance specification. The two aspects are frequently reciprocal, that is measures taken to improve emissions will also improve the susceptibility, though this is not invariably so. For analysis, they are more easily considered separately.

Systems EMC

Putting source and victim together shows the potential interference routes that exist from one to the other (Figure 5.1). When systems are being built, you need to know the emissions signature and susceptibility of the component equipment, to determine whether problems are likely to be experienced with close coupling. Adherence to published emission and susceptibility standards does not guarantee freedom from systems EMC problems. Standards are written from the point of view of protecting a particular service – in the case of emissions standards, this is radio broadcast and telecommunications – and they have to assume a minimum separation between source and victim.

Most electronic hardware contains elements which are capable of antenna-like behaviour, such as cables, pcb tracks, internal wiring and mechanical structures. These elements can unintentionally transfer energy via electric, magnetic or electromagnetic fields which couple with the circuits. In practical situations, intra-system and external coupling between equipment is modified by the presence of screening and dielectric materials, and by the layout and proximity of interfering and victim equipment and especially their respective cables. Ground or screening planes will enhance an interfering signal by reflection or attenuate it by absorption. Cable-to-cable coupling can be either capacitive or inductive and depends on orientation, length and proximity. Dielectric materials may also reduce the field by absorption, though this is negligible compared with the effects of conductors in most practical situations.

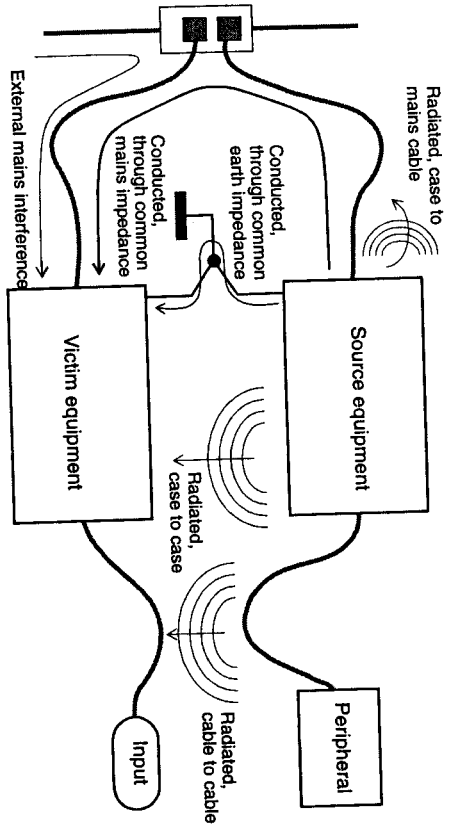

Figure 5.1 Coupling paths

5.1.1 Common Impedance coupling

Common impedance coupling routes are those which are due to a circuit impedance which the source shares with the victim. The most obvious common impedances are those in which the impedance is physically present, as with a shared conductor; but the those in which the impedance is physically present, as with a shared conductor; but the common impedance may also be due to mutual inductive coupling between two current loops, or to mutual capacitive coupling between two voltage nodes. Philosophically speaking, every node and every loop is coupled to all others throughout the universe. Practically, the strength of coupling falls off very rapidly with distance. Figure 5.4 shows the variation of mutual capacitance and inductance of a pair of parallel wires versus their separation, and the field equations in Appendix C (section C.3) give the precise expressions for the field at any point due to a radiating element.

5.1.1.1 Conductive connection

When an interference source (output of system A in Figure 5.2) shares a ground connection with a victim (input of system B) then any current due to A's output flowing through the common impedance section X-X develops a voltage in series with B's input. The common impedance need be no more than a length of wire or pcb track. High frequency or high di/dt components in the output will couple more efficiently because of the inductive nature of the impedance (see appendix C section C.5 for the inductance of various conductor configurations). The voltage developed across an inductor as a result of current flow through it is given by equation (5.1). The output and input may be part of the same system, in which case there is a spurious feedback path through the common impedance which can cause oscillation.

$$V_N = -L \cdot di/dt \tag{5.1}$$

where L is the self inductance in henries

The solution as shown in Figure 5.2 is to separate the connections so that there is no common current path, and hence no common impedance, between the two circuits. The

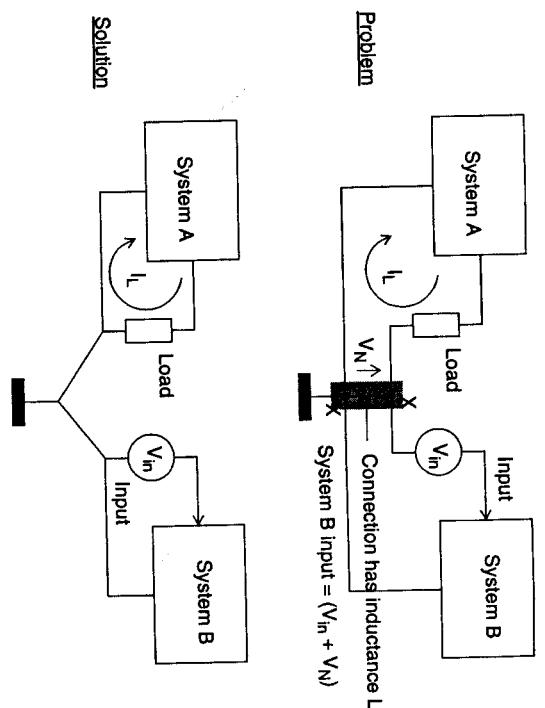

Figure 5.2 Conducted common impedance coupling

only "penalty" for doing this is the need for extra wiring or track to define the separate circuits. This applies to any circuit which may include a common impedance, such as power rail connections. Grounds are the most usual source of common impedance because the ground connection, often not shown on circuit diagrams, is taken for granted.

5.1.1.2 Magnetic induction

Alternating current flowing in a conductor creates a magnetic field which will couple with a nearby conductor and induce a voltage in it (Figure 5.3(a)). The voltage induced in the victim conductor is now given by equation (5.2):

$$V_N = -M \cdot di/dt \tag{5.2}$$

where M is the mutual inductance in henries

Notice the similarity between this and equation (5.1). M depends on the areas of the source and victim current loops, their orientation and separation distance, and the presence of any magnetic screening. Appendix C (section C.5) gives mutual inductance formulae, but typical values for short lengths of cable loomed together lie in the range 0.1 to 3µH. The equivalent circuit for magnetic coupling is a voltage generator in series with the victim circuit. The coupling is unaffected by whether or not there is a direct connection between the two circuits; the induced voltage would be the same if the circuits were isolated or connected to ground.

5.1.1.3 Electric induction

Changing voltage on one conductor creates an electric field which may couple with a nearby conductor and induce a voltage on it (Figure 5.3(b)). The voltage induced on the victim conductor in this manner is:

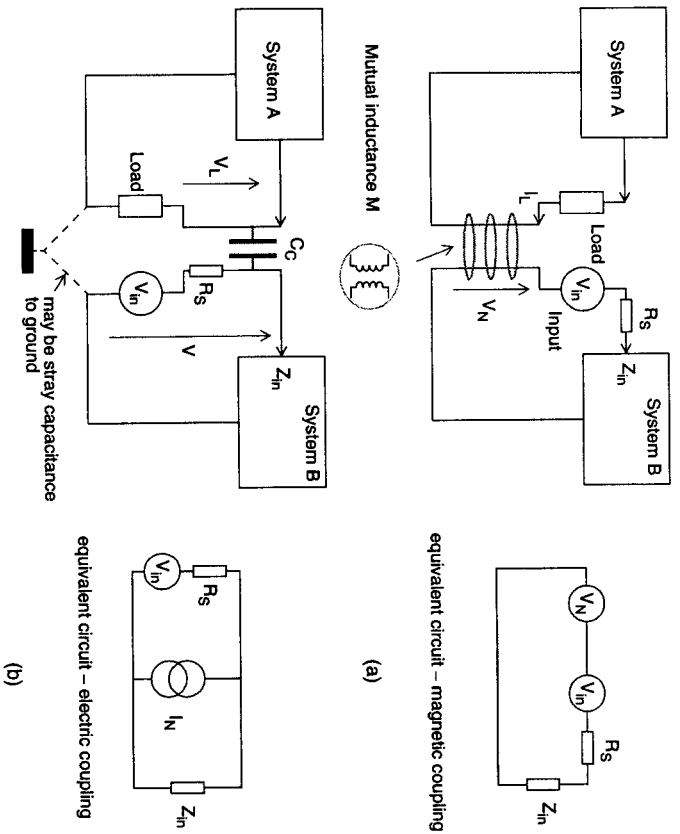

Figure 5.3 Magnetic and electric induction

$$V_N = C_C \cdot dV_L/dt \cdot Z_{in}/R_S \tag{5.3}$$

where C_C is the coupling capacitance and Z_{in}/R_S is the impedance to ground of the victim circuit

This assumes that the impedance of the coupling capacitance is much higher than that of the circuit impedances. The noise is injected as if from a current source with a value of $C_C \cdot dV_L/dt$. The value of C_C is a function of the distance between the conductors, their effective areas and the presence of any electric screening material. Typically, two parallel insulated wires 0.1" apart show a coupling capacitance of about 50pF per metre; the primary-to-secondary capacitance of an unscreened medium power mains transformer is 100–1000pF.

Floating circuits

In this case, both circuits need to be referenced to ground for the coupling path to be complete. But if either is floating, this does *not* mean that there is no coupling path: the floating circuit will exhibit a stray capacitance to ground and this is in series with the direct coupling capacitance. Alternatively, there will be stray capacitance direct from the circuit nodes of system A to B even in the absence of any ground node. The noise current will still be injected across R_L but its value will be determined by the series combination of C_C and the other stray capacitance.

5.1.1.4 Effect of input impedance

Note that the behaviour in equivalent circuits for magnetic and electric coupling means that their behaviour with a varying circuit input impedance is different. Electric field coupling *increases* with an increasing Z_{in} while magnetic field coupling *decreases* with an increasing Z_{in} . This property can be useful for diagnostic purposes; if you are able to vary Z_{in} while observing the coupled voltage, you can deduce which mode of coupling predominates. For the same reason, magnetic coupling is more of a problem for low-impedance circuits while electric coupling applies to high impedance circuits.

5.1.1.5 Spacing

Both mutual capacitance and mutual inductance are affected by the physical separation of source and victim conductors. Figure 5.4 shows the effect of spacing on mutual capacitance of two parallel wires in free space, and on mutual inductance of two conductors over a ground plane (the ground plane provides a return path for the current). Appendix C includes the equations from which this graph derives.

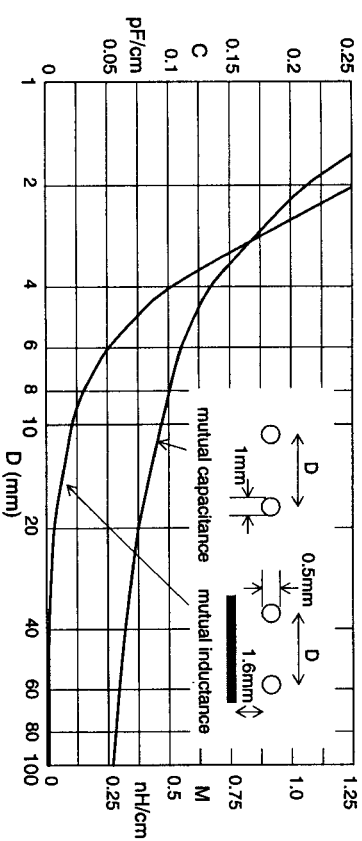

Figure 5.4 Mutual capacitance and inductance versus spacing

5.1.2 Distributed near field coupling

5.1.2.1 Low frequency model

The discussion in 5.1.1.2 and 5.1.1.3 assumes that the coupling mechanism – inductive or capacitive – occurs at a single point in the circuit, or at least can be approximated to such a point. It also assumes that inductive and capacitive coupling can be treated quite separately. In reality, and particularly in cables and on PCB tracks, neither assumption is justifiable. When near-field coupling between circuits is distributed over an appreciable length then the two mechanisms interact and the circuit must be analysed in more detail.

Consider the equivalent circuit of two conductors in a cable as shown in Figure 5.5. For the purposes of the analysis we can assume that the current return paths are both via a remote ground plane. The interference is induced in the second circuit magnetically, in series with the conductor (V_M) and capacitively in parallel with it (V_C). Then the sum total of the interference at each end is given by the superposition of the two sources. But since the magnetically induced voltage is in series with the conductor it appears with

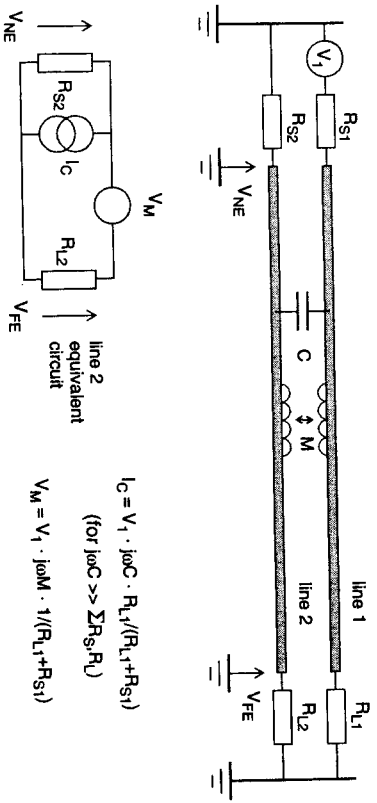

Figure 5.5 Superposition of inductive and capacitive coupling

one sign at one end but the opposite sign at the far end:

$$V_{NE}(C) = I_C \cdot R_{S2}/R_{L2} = V_{FE}(C) \quad (\text{Capacitive coupling}) \quad (5.4)$$

$$V_{NE}(L) = V_M \cdot R_{S2}/(R_{S2}+R_{L2}) = -V_{FE}(L) \quad (\text{Inductive coupling}) \quad (5.5)$$

So

$$V_{NE}(C) = V_{NE}(C) + V_{NE}(L) = (I_C \cdot R_{L2} + V_M) \cdot (R_{S2}/(R_{S2}+R_{L2})) \quad (5.6)$$

$$V_{FE}(C) = V_{FE}(C) + V_{FE}(L) = (I_C \cdot R_{L2} - V_M) \cdot (R_{S2}/(R_{S2}+R_{L2})) \quad (5.7)$$

Since this is a crosstalk phenomenon it gives rise to the terms "near-end crosstalk" (NEXT) and "far-end crosstalk" (FEXT).

5.1.2.2 High frequency model

The above model is only valid at low frequencies, that is if the length of the coupled lines is much less than a wavelength. A more general approach treats the two conductors as transmission lines with lumped L and C parameters, and integrates the coupling contributions along the length of the line. These parameters together with the source and load terminating impedances then determine the coupling time constants. Appendix C section C.5 gives the full coupling equations, and Figure 5.6 shows their effect: at frequencies below the breakpoint determined by the terminated line's time constant, the LF model applies and the coupling increases monotonically with frequency. At higher frequencies the lines become resonant and a maximum coupling is reached, followed by a series of nulls and peaks at integer multiples of a half wavelength.

5.1.3 Mains coupling

Interference can propagate from a source to a victim via the mains distribution network to which both are connected. This is not well characterized at high frequencies, especially since connected electrical loads can present virtually any RF impedance at their point of connection. We have already seen that the RF impedance presented by the

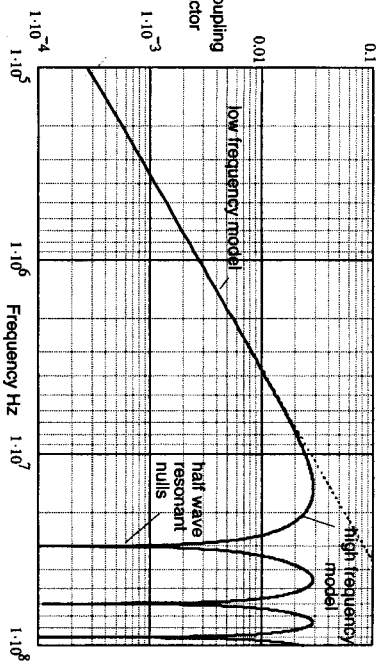

Figure 5.6 High frequency line coupling, line length 5m

mains can on the average be approximated by a network of 50Ω in parallel with 50μH (section 3.1.2.3). For short distances such as between adjacent outlets on the same ring, coupling via the mains connection of two items of equipment can be represented by the equivalent circuit of Figure 5.7.

Over longer distances, power cables are fairly low loss transmission lines of around 150–200Ω characteristic impedance up to about 10MHz. However, in any local power distribution system the disturbances and discontinuities introduced by load connections, cable junctions and distribution components will dominate the RF transmission characteristic. These all tend to increase the attenuation.

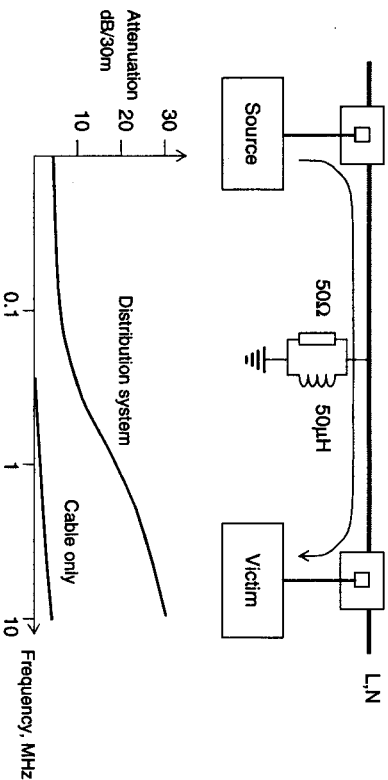

Figure 5.7 Coupling via the mains network

5.1.4 Radiated coupling

To understand how energy is coupled from a source to a victim at a distance with no intervening connecting path, you need to have a basic understanding of electromagnetic

wave propagation. This section will do no more than introduce the necessary concepts. The theory of EM waves has been well covered in many other works [31][7][14].

5.1.4.1 Field generation

An electric field (E field) is generated between two conductors at different potentials. The field is measured in volts per metre and is proportional to the applied voltage divided by the distance between the conductors.

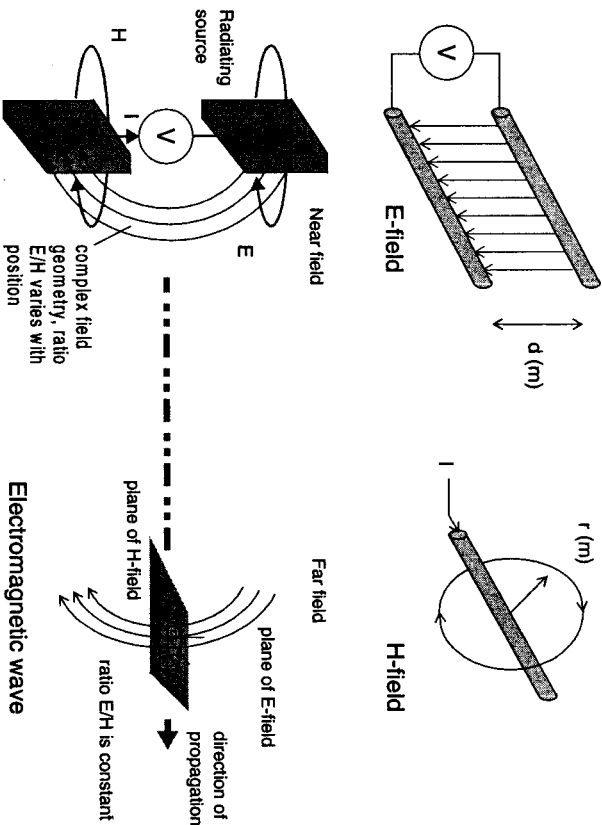

Figure 5.8 Electromagnetic fields

A magnetic field (H field) is generated around a conductor carrying a current, is measured in amps per metre and is proportional to the current divided by the distance from the conductor.

When an alternating voltage generates an alternating current through a network of conductors – a description which applies to any electronic circuit – an electromagnetic (EM) wave is generated which propagates as a combination of E and H fields. The speed of propagation is determined by the medium; in free space it is equal to the speed of light, $3 \cdot 10^8$ m/s. Near to the radiating source the geometry and strength of the fields depend on the characteristics of the source. A conductor carrying a significant dv/dt will generate mostly a magnetic field; a circuit node carrying a significant di/dt will generate mostly an electric field. The structure of these fields will be determined by the physical layout of the source conductors, as well as by other conductors, dielectrics and permeable materials nearby. Further away from the source, the complex three-dimensional field structure decays and only the components which are orthogonal to each other and to the direction of propagation remain. Figure 5.8 demonstrates these concepts graphically.

5.1.4.2 Wave impedance

The ratio of the electric to magnetic field strengths (E/H) is called the wave impedance (Figure 5.9). The wave impedance is a key parameter of any given wave as it determines the efficiency of coupling with another conducting structure, and also the effectiveness of any conducting screen which is used to block it. In the far field, that is for $d > \lambda/2\pi$, the wave is known as a plane wave and the E and H fields decay with distance at the same rate. Therefore its impedance is constant, and is equal to the impedance of free space given by equation (5.8):

$$Z_0 = \sqrt{(\mu_0/\epsilon_0)} = 120\pi = 377\Omega \tag{5.8}$$

where μ_0 is $4\pi \cdot 10^{-7}$ H/m (the permeability of free space)
and ϵ_0 is $8.85 \cdot 10^{-12}$ F/m (the permittivity of free space)

In the near field, $d < \lambda/2\pi$, the wave impedance is determined by the characteristics of the source. A low current, high voltage radiator (such as a rod) will generate mainly an electric field of high impedance, while a high current, low voltage radiator (such as a loop) will generate mainly a magnetic field of low impedance. If (as a special case) the radiating structure happens to have an impedance around 377Ω , then a plane wave can in fact be generated in the near field, depending on geometry.

The region around $\lambda/2\pi$, or approximately one sixth of a wavelength, is the transition region between near and far fields. This is not a precise criterion, rather it indicates the region within which the field structure changes from complex to simple. Plane waves are always assumed to be in the far field, while if you are looking at the near field it is necessary to consider individual electric or magnetic fields separately. Appendix C presents the formulae (Maxwell's field equations) that underpin this description.

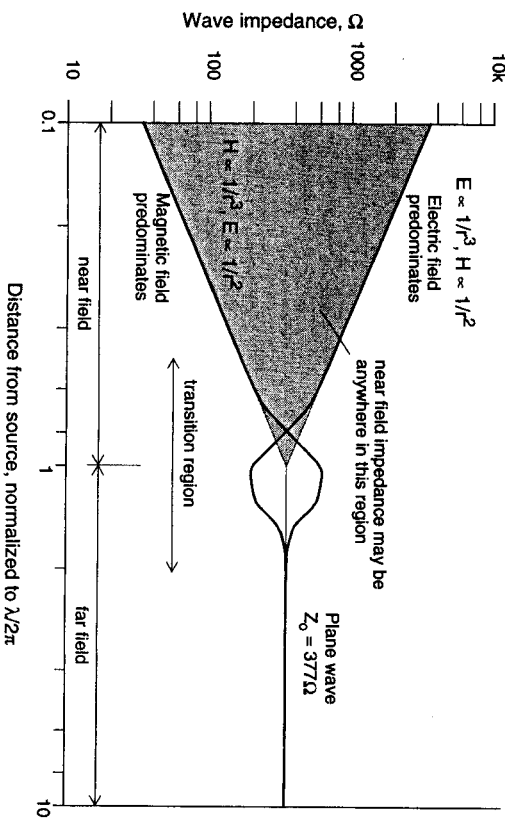

Figure 5.9 The wave impedance

5.1.4.3 The Rayleigh criterion

There is another definition of the transition between near and far fields, determined by the Rayleigh range. This has to do not with the field structure according to Maxwell's equations, but with the nature of the radiation pattern from any physical antenna (or equipment under test) which is too large to be a point source. For the far field assumption to hold, the phase difference between the field components radiated from the extremities of the antenna must be small and therefore the path differences to these extremities must also be small in comparison to a wavelength. This produces a criterion that relates the wavelength and the maximum dimension of the antenna (or EUT) to the distance from it. Using the Rayleigh criterion, the far field is defined as beyond a distance:

$$d > 2D^2/\lambda \quad (5.9)$$

where D is the maximum dimension of the antenna

Table 5.1 shows a comparison of the distances for the two criteria for the near field/far field transition for various frequencies and EUT dimensions. Note how for typical EUT dimensions the Rayleigh range determines the far field condition above 100–200MHz.

Table 5.1 Rayleigh and Maxwell distances for transition to far field

Frequency	Maximum dimension D (m)	Rayleigh $d = 2D^2/\lambda$ (m)	Maxwell $d = \lambda/2\pi$ (m)
10MHz	1	0.067	4.77
	3	0.6	
30MHz	1	0.2	1.59
	3	0.6	
	0.3	0.06	
100MHz	1	0.67	0.477
	3	6.0	
	0.3	0.18	
300MHz	1	2.0	0.159
	0.3	0.6	
1GHz	0.3	0.6	0.0477
	1	6.67	

5.1.5 Coupling modes

The concepts of differential mode, common mode and antenna mode radiated field coupling are fundamental to an understanding of EMC and will crop up in a variety of guises throughout this book. They apply to coupling of both emissions and incoming interference.

5.1.5.1 Differential mode

Consider two items of equipment interconnected by a cable (Figure 5.10). The cable carries signal currents in *differential* mode (go and return) down the two wires in close

proximity. A radiated field can couple to this system and induce differential mode interference between the two wires; similarly, the differential current will induce a radiated field of its own. The ground reference plane (which may be external to the equipment or may be formed by its supporting structure) plays no part in the coupling.

5.1.5.2 Common mode

The cable also carries currents in *common* mode, that is, all flowing in the same direction on each wire. These currents very often *have nothing at all to do with the signal currents*. They may be induced by an external field coupling to the loop formed by the cable, the ground plane and the various impedances connecting the equipment to ground, and may then cause internal differential currents to which the equipment is susceptible. Alternatively, they may be generated by internal noise voltages between the ground reference point and the cable connection, and be responsible for radiated emissions. The existence of RF common mode currents means that *no* cable, whatever signal it may be intended to carry – even a single wire – can be viewed as safe from the EMC point of view.

Notice that the stray capacitances and inductances associated with the wiring and enclosure of each unit are an integral part of the common mode coupling circuit, and play a large part in determining the amplitude and spectral distribution of the common mode currents. These stray impedances are incidental rather than designed in to the equipment. They don't appear on any circuit diagram, and are much harder to control or predict than those parameters such as cable spacing and filtering which determine differential mode coupling.

5.1.5.3 Antenna mode

Antenna mode currents are carried in the same direction by the cable and the ground reference plane. They should not arise as a result of internally-generated noise, but they will flow when the whole system, ground plane included, is exposed to an external field. An example would be when an aircraft flies through the beam of a radar transmission; the aircraft structure, which serves as the ground plane for its internal equipment, carries the same currents as the internal wiring. Antenna mode currents only become a problem for the radiated field susceptibility of self-contained systems when they are converted to differential or common mode by varying impedances in the different current paths.

5.1.5.4 Conversion between differential and common mode

Although it was said above that common mode currents may be unrelated to the intended signal currents, there may also be a component of common mode current which *is* due to the signal current. Conversion occurs when the two signal conductors present differing impedances to their environment, represented by the external ground. These impedances are dominated at RF by stray capacitance and inductance related to physical layout, and are only under the circuit designer's control if that person is also responsible for physical layout.

In Figure 5.11 the differential mode current I_{DM} produces the desired signal voltage across load R_L . The common mode current I_{CM} does not flow through R_L directly but through impedances Z_A , Z_B and back via the external ground. Z_A , Z_B are not circuit components but distributed stray impedances, typically but not always capacitive, and are determined by such factors as surface area of PCB tracks and components and their proximity to chassis metalwork and other parts of the equipment. If $Z_A = Z_B$ then no

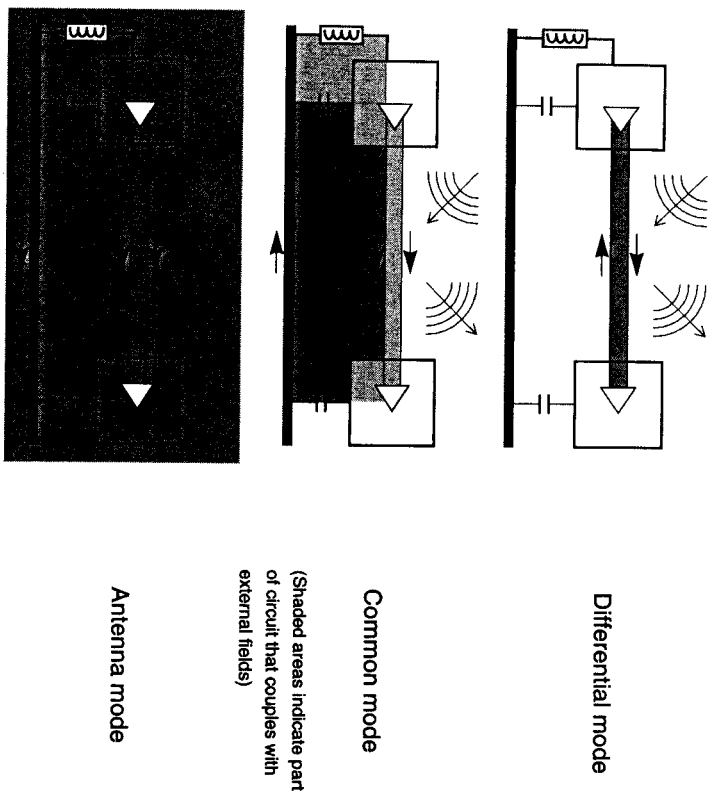

Figure 5.10 Radiated coupling modes

voltage is developed across R_L by the common mode currents I_{CM} . But any inequality results in such a voltage, proportional to the differences in impedance:

$$V_{load(CM)} = I_{CM}Z_A - I_{CM}Z_B = I_{CM}(Z_A - Z_B) \quad (5.10)$$

For this reason, circuits which carry high-frequency interfering signals (such as wideband data or video) or which could be susceptible to RF are best designed in such a way that the stray impedances of each conductor are balanced as nearly as possible. Alternatively, a common-mode choke (section 8.2.4.1) is used which swamps the imbalance of the strays and reduces the magnitude of I_{CM} .

The increasing popularity of wideband data transmission via unscreened cables within and between buildings has sharpened the problem of interference radiated from these cables. As well as the balance of the circuit at either end of the cable, the balance of the cable itself, as it passes near to other conducting structures in its environment, is an important factor. This is largely determined by the quality of the cable construction, and has resulted in a cable parameter known as "longitudinal conversion loss" (LCL) being defined. LCL is treated in more detail in section 8.1.7.1.

5.1.5.5 Generalization

The principles demonstrated in the circuits of Figure 5.10 and Figure 5.11 are not limited to currents propagating down cables between modules. The circuits can be

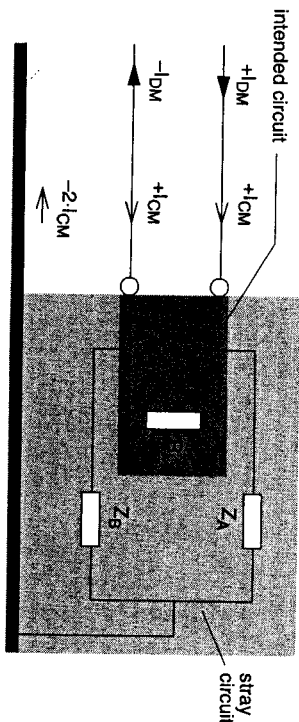

Figure 5.11 Differential to common mode conversion

extended to include currents on interconnections between PCBs in an individual module, or even on tracks between parts of a PCB mounted on a chassis. Many EMC problems of products can be traced to the common mode currents flowing *within* them as well as outside them.

5.2 Emissions

When designing a product to a specification without knowledge of the system or environment in which it will be installed, you will normally separate the two aspects of emissions and susceptibility, and design to meet minimum requirements for each. Limits are laid down in various standards but individual customers or market sectors may have more specific requirements. In those standards which derive from CISPR (see Chapter 2), emissions are subdivided into radiated emissions from the system as a whole, and conducted emissions present on the interface and power cables. Conventionally, the breakpoint between radiated (high frequency) and conducted (low frequency) is set at 30MHz, primarily for convenience of measurement. Radiated emissions can themselves be separated into emissions that derive from differential currents on internal PCBs or other wiring, and emissions from common-mode currents on PCBs or conducting structures, or that find their way onto external cables that are connected to the equipment.

5.2.1 Radiated emissions

5.2.1.1 Radiation from the pcb

In most equipment, the primary sources are currents flowing in circuits (clocks, video and data drivers, and other oscillators) that are mounted on printed circuit boards. Some of the energy is radiated directly from the pcb, which can be modelled as a small loop antenna carrying the interference current (Figure 5.12). A small loop is one whose dimensions are smaller than a quarter wavelength ($\lambda/4$) at the frequency of interest (e.g. 1 metre at 75MHz). Most pcb loops count as "small" at emission frequencies of up to a few hundred MHz. When the dimensions approach $\lambda/4$ the currents at different points on the loop appear out of phase at a distance, so that the effect is to reduce the field strength at any given point. The maximum electric field strength from such a loop over

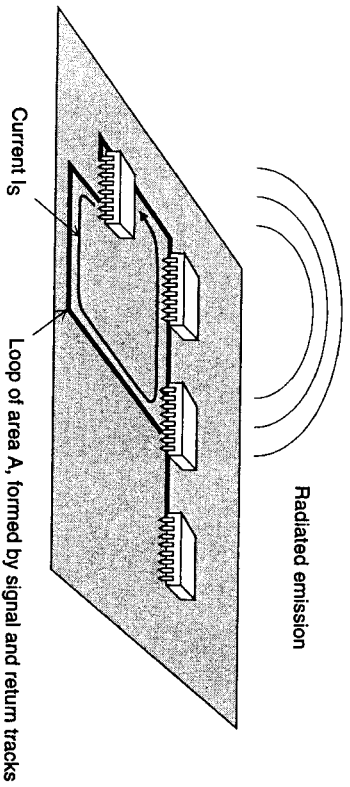

Figure 5.12 PCB radiated emissions

a ground plane at 10 metres distance is proportional to the square of the frequency:

$$E = 263 \cdot 10^{-12} (f^2 \cdot A \cdot I_s) \text{ volts per metre [12]} \quad (5.11)$$

where A is the loop area in cm^2 ,

f (MHz) is the frequency of I_s the source current in mA.

In free space, the field falls off proportionally to distance from the source. The figure of 10m is used as this is the standard measurement distance for the European radiated emissions standards. A factor of 2 times is allowed for worst case field reinforcement due to reflection from the ground plane, which is also a required feature of testing to standards.

The loop whose area must be known is the overall path taken by the signal current and its return. Equation (5.11) assumes that I_s is at a single frequency. For square waves with many harmonics, the Fourier spectrum must be used for I_s . These points are taken up again in section 7.1.2.

Assessing pcb design

You can use equation (5.11) to indicate roughly whether a given pcb design will need extra screening. For example if $A = 10\text{cm}^2$, $I_s = 20\text{mA}$, $f = 50\text{MHz}$ then the field strength E is $42\text{dB}\mu\text{V/m}$, which is 12dB over the European Class B limit. Thus if the frequency and operating current are fixed, and the loop area cannot be reduced, screening will be necessary.

But the converse is not true. Differential mode radiation from small loops on pcbs is by no means the only contributor to radiated emissions; common mode currents flowing on the pcb and on attached cables can contribute much more. Paul [106] goes so far as to say:

"predictions of radiated emissions based solely on differential-mode currents will generally bear no resemblance to measured levels of radiated emissions. Therefore, basing system EMC design on differential-mode currents and the associated prediction models that use them exclusively while neglecting to consider the (usually much larger) emissions due to common-mode currents can lead to a strong 'false sense of security'."

Common mode currents on the pcb itself are not at all easy to predict, in contrast with the differential mode currents which are governed by Kirchoff's current law. The return path for common mode currents is via stray capacitance (displacement current) to other

nearby objects and therefore a full prediction would have to take the detailed mechanical structure of the pcb and its case, as well as its proximity to ground and to other equipment, into account. Except for trivial cases this is to all intents and purposes impossible. It is for this reason more than any other that EMC design has earned itself the distinction of being a "black art".

5.2.1.2 Radiation from cables

Fortunately (from some viewpoints) radiated coupling at VHF tends to be dominated by cable emissions, rather than by direct radiation from the pcb. This is for the simple reason that typical cables resonate in the 30–100MHz region and their radiating efficiency is higher than pcb structures at these frequencies. The interference current is generated in common mode from ground noise developed across the PCB or elsewhere in the equipment and may flow along the conductors, or along the shield of a shielded cable. A model for this effect has been well described in [33]: simplistically, the capacitances between the noise-generating track and external ground, and between the PCB's ground reference and external ground, form a network for return of currents that are injected into cables connected to the PCB. A more detailed model can be generated which includes the inductance of the tracks and plane. Reference [33] describes how it is possible from this model to derive coupling parameters for a PCB which can then be applied to the large-scale system (enclosure and cables) of which the PCB is a part, to predict the common mode radiated emissions.

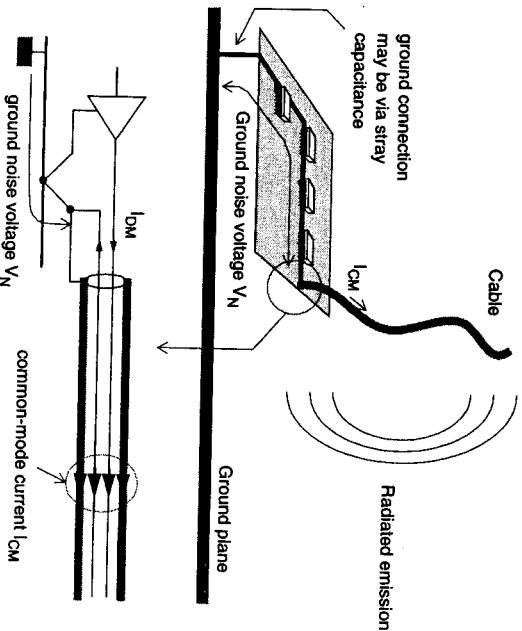

Figure 5.13 Cable radiated emissions

The model for cable radiation at lower frequencies (Figure 5.13) is a short ($L < \lambda/4$) monopole antenna over a ground plane. (When the cable length is resonant the model becomes invalid; see section C.3 in appendix C for an equation describing emissions from resonant cables.) The maximum field strength allowing +6dB for ground plane reflections at 10m due to this radiation is directly proportional to frequency:

$$E = 1.26 \cdot 10^{-4} \cdot (f \cdot L \cdot I_{CM}) \text{ volts per metre [12]} \quad (5.12)$$

where L is the cable length in metres and

I_{CM} is the common-mode current at f MHz in mA flowing in the cable.

For a 1m cable, I_{CM} must be less than 20µA for a 10m-distance field strength at 50MHz of 42dBµV/m – i.e., a thousand times less than the equivalent differential mode current! To meet the 30dBµV/m limit, the current needs to be 12dB or four times less, i.e. 5µA, under these conditions. And indeed, this value of 5µA when measured as a common-mode cable current is regarded as a good indicator of likely compliance with radiated emissions limits [5] – any more than 5µA and the product has a good chance of failing the compliance test. I_{CM} can be easily measured in the development lab using a current probe or absorbing clamp (see section 3.1.2.5) and so this forms a useful diagnostic or pre-compliance check on the prospects for a given item.

Common mode cable noise

At the risk of repetition, it is vital to appreciate the difference between common mode and differential mode cable currents. Differential mode current, I_{DM} in Figure 5.13, is the current which flows in one direction along one cable conductor and in the reverse direction along another. It is normally equal to the signal or power current, and is not present on the shield. It contributes little to the net radiation as long as the total loop area formed by the two conductors is small; the two currents tend to cancel each other. Common mode current I_{CM} flows equally in the same direction along all conductors in the cable, potentially including the shield, and is only related to the (differential) signal currents insofar as these are converted to common mode by unbalanced external impedances, and may be quite unrelated to them. For instance, an RS-232 interface cable will only be carrying data at a rate of perhaps 19.2kbaud, but can also carry common mode noise from the circuit ground which is polluted by a processor clock and its harmonics at hundreds of MHz. It returns via the associated ground network and therefore the radiating loop area is large and uncontrolled. As a result, even a small I_{CM} can result in large emitted signals.

5.2.2 Conducted emissions

Interference sources within the equipment circuit or its power supply are coupled onto the power cable to the equipment. Interference may also be coupled either inductively or capacitively from another cable onto the power cable. Until recently, attention has focussed on the power cable as the prime source of conducted emissions since CISPR-based standards have only specified measurements on this cable. However, signal and control cables can and do also act as coupling paths and the latest versions of the standards apply measurements to these cables as well.

The resulting interference may appear as differential mode (between live and neutral, or between signal wires) or as common mode (between live/neutral/signal and earth) or as a mixture of both. For signal and control lines, only common mode currents are of interest. For the mains port, the voltages between each phase/neutral and earth at the far end of the mains cable are measured. Differential mode emissions are normally associated with low-frequency switching noise from the power supply, while common-mode emissions can be due to the higher frequency switching components, internal circuit sources or inter-cable coupling.

5.2.2.1 Coupling paths

Figure 5.14, showing a typical product with a switched mode supply, gives an idea of

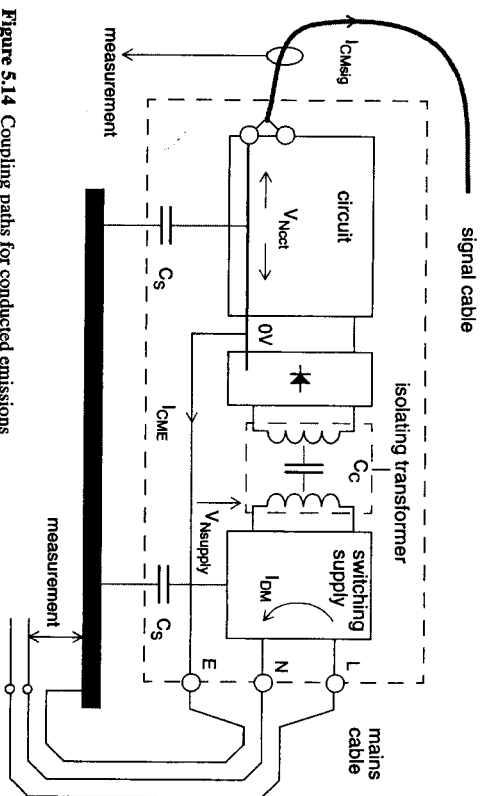

Figure 5.14 Coupling paths for conducted emissions

the various paths these emissions can take. (Section 7.1.5 looks at SMPS emissions in more detail.) Differential mode current I_{DM} generated at the input of the switching supply is measured as an interference voltage across the load impedance of each line with respect to earth at the measurement point. Higher frequency switching noise components $V_{NSupply}$ are coupled through C_s , the coupling capacitance between primary and secondary of the isolating transformer, to appear between L/N and E on the mains cable, and C_s to appear with respect to the ground plane. Circuit ground noise V_{Neat} (digital noise and clock harmonics) is referenced to ground by C_s and coupled out via signal cables as I_{CMsig} or via the safety earth as I_{CME} .

The problem in a real situation is that all these mechanisms are operating simultaneously, and the stray capacitances C_s are widely distributed and unpredictable, depending heavily on proximity to other objects if the case is unscreened. A partially-screened enclosure may actually worsen the coupling because of its higher capacitance to the environment.

5.2.2.2 Simplified equivalent circuits

The basic equivalent circuit for conducted emissions testing on the mains port is shown in Figure 5.15(a). The mains connection is represented by the AMN/LISN giving a defined RF impedance between live and earth, and between neutral and earth. The EUT contains both differential and common mode sources, generalized here as appearing in one case between live and neutral, and in the other case between both live and neutral with respect to earth. If the apparatus is Safety Class II there is no earth wire, but common mode signals can still return via the stray capacitance to the ground plane.

Differential mode sources appear between live and neutral connections without reference to the earth connection (Figure 5.15(b)). In circuits with switch-mode power supplies or other power switching circuits the RF emissions are dominated by interference developed across the DC link to the switching devices. Although there will normally be a reservoir capacitor, the high di/dt through this capacitor will generate voltages at the harmonics of the switching frequency across its equivalent series impedance. Diode noise, if it is significant, will also appear in differential mode.

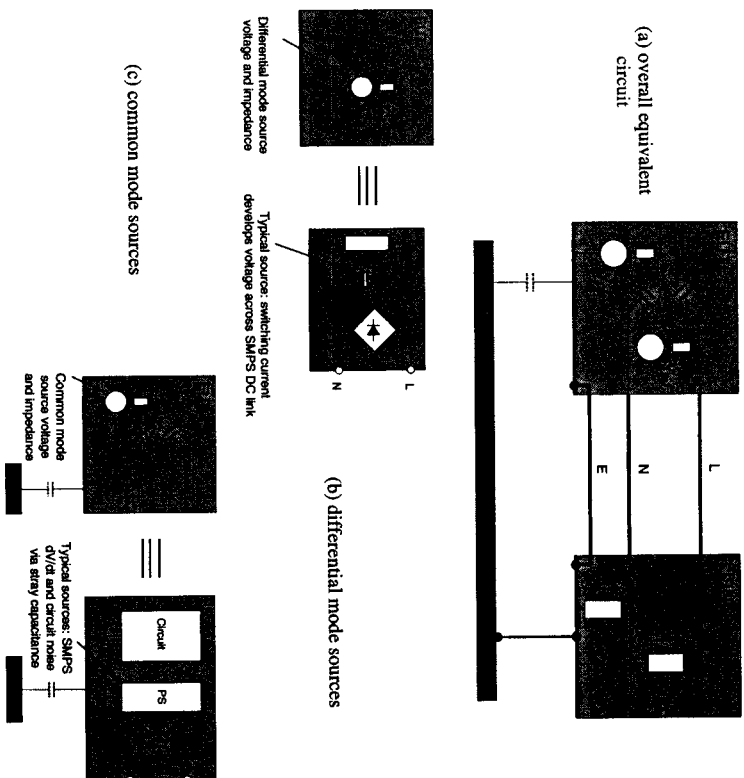

Figure 5.15 Equivalent circuits for conducted emissions tests

Common mode sources (Figure 5.15(c)) are more complex. The common mode voltage appears between both live and neutral with respect to earth. Since the mains input is normally isolated from earth, it is usual for common mode coupling to be capacitive.

The coupling is dominated by the intertwining capacitance of the isolating transformer and the stray capacitances of noise sources, both in the power supply (e.g. from heatsinks) and the operating circuit. These capacitances are referred to earth, either directly or via the enclosure if this is conductive. A well-shielded enclosure will minimise “leakage” of this capacitive coupling and hence reduced conducted emissions. Other impedances may appear in the coupling path: for instance the leakage inductance of the isolating transformer is in series with its intertwining capacitance and may give a series resonant peak in the MHz range.

5.3 Immunity

Electronic equipment will be susceptible to environmental electromagnetic fields and/or to disturbances coupled into its ports via connected cables. An electrostatic discharge may be coupled in via the cables or the equipment case, or a nearby discharge can create a local field which couples directly with the equipment. The potential threats are:

- radiated RF fields
- conducted transients
- electrostatic discharge (ESD)
- magnetic fields
- supply voltage disturbances

Quite apart from legal requirements, equipment that is designed to be immune to these effects – especially ESD and transients – will save its manufacturer considerable expense through improved reliability and reduced field returns. Although many aspects of emission control are also relevant for immunity, in some cases the shielding and circuit suppression measures that are required for protection against ESD or RF interference may be more than you need for simple compliance with emission standards.

5.3.1 Radiated field

An external field can couple either directly with the internal circuitry and wiring in differential mode or with the cables to induce a common mode current (Figure 5.16). Coupling with internal wiring and pcb tracks is most efficient at frequencies above a

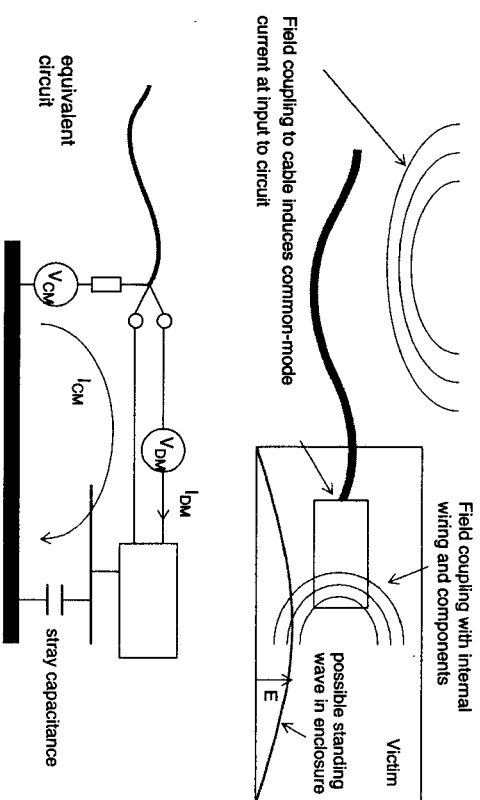

Figure 5.16 Radiated field coupling

few hundred MHz, since wiring lengths of a few inches approach resonance at these frequencies.

RF voltages or currents in analogue circuits can induce nonlinearity, overload or DC bias and in digital circuits can corrupt data transfer [111]. Modulated fields can have greater effect than unmodulated ones. Likely sources of radiated fields are walkie-talkies, cellphones, high-power broadcast transmitters and radars. Field strengths between 1 and 10V/m from 20MHz to 1GHz are typical, and higher field strengths can occur in environments close to such sources.

Reciprocity

Because the coupling mechanisms for immunity are essentially the same as those for emissions, the principle of *reciprocity* has evolved. In essence it states that

improvements to coupling which reduce emissions over a particular frequency range will also improve immunity over that frequency range

or, on the other hand,

frequencies at which emissions are particularly troublesome will also be those at which immunity problems occur.

This concept relies on the fact that coupling mechanisms usually show resonant behaviour which maximizes the coupling at certain frequencies. The reciprocity principle should not be accorded too much weight: actual EMC performance depends on the operation of both source and victim circuits as well as on the coupling between them, and these are rarely either reciprocal or linear. Understanding the principle can help in dealing with many coupling-related problems, though.

5.3.1.1 Cable resonance

Cables are most efficient at coupling RF energy into equipment at the lower end of the vhf spectrum (30–100MHz). The external field induces a common mode current on the cable shield or on all the cable conductors together, if it is unshielded. The common mode cable current effects tend to dominate the direct field interactions with the equipment as long as the equipment's dimensions are small compared with half the wavelength of the interfering signal.

A cable connected to a grounded victim equipment can be modelled as a single conductor over a ground plane, which appears as a transmission line (Figure 5.17, and compare this also to Figure 5.6). The current induced in such a transmission line by an external field increases steadily with frequency until the first resonance is reached, after which it exhibits a series of peaks and nulls at higher resonances [20]. The coupling mechanism is enhanced at the resonant frequency of the cable, which depends on its length and on the reactive loading of whatever equipment is attached to its end. A length of 2 metres is quarter-wave resonant at 37.5MHz, half-wave resonant at 75MHz.

Cable loading

The dominant resonant mode depends on the RF impedance (high or low) at the distant end of the cable. If the cable is connected to an ungrounded object such as a hand controller it will have a high RF impedance, which will cause a high coupled current at quarter-wave resonance and high coupled voltage at half-wave. Extra capacitive loading such as body capacitance will lower its apparent resonant frequency.

Conversely, a cable connected to another grounded object such as a separately earthed peripheral will see a low impedance at the far end, which will generate high coupled current at half-wave and high coupled voltage at quarter-wave resonance. Extra inductive loading, such as the inductance of the earth connection, will again tend to lower the resonant frequency.

These effects are summarized in Figure 5.18. The RF common mode impedance of the cable varies from around 35Ω at quarter wave resonance to several hundred ohms maximum. A convenient average figure (and one that is taken in many standards) is 150Ω . Because cable configuration, layout and proximity to grounded objects are outside the designer's control, attempts to predict resonances and impedances accurately are unrewarding.

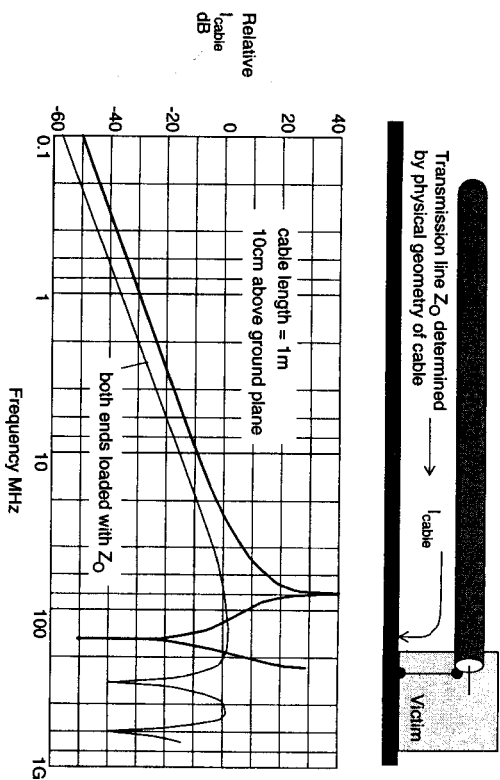

Figure 5.17 Cable coupling to radiated field

5.3.1.2 Current injection

A convenient method for testing the RF susceptibility of equipment without reference to its cable configuration is to inject RF as a common mode current or voltage directly onto the cable port (see also section 4.1.4)[90]. This represents real-life coupling situations at lower frequencies well, until the equipment dimensions approach a half wavelength. It can also reproduce the fields (E_{RF} and H_{RF}) associated with radiated field coupling. The route taken by the interference currents, and hence their effect on the circuitry, depends on the various internal and external RF impedances to earth, as shown in Figure 5.19. Connecting other cables will modify the current flow to a marked extent, especially if the extra cables interface to a physically different location on the pcb or equipment. An applied voltage of 1V, or an injected current of 3–10mA, can be taken to correspond in typical cases to a radiated field strength of 1V/m. However there is considerable disagreement over any single figure for conversion from radiated to injected, and it is generally accepted that conducted tests do not directly represent radiated tests at all [107], because of the variability attributable to multiple cable connections.

5.3.1.3 Cavity resonance

A screened enclosure can form a resonant cavity; standing waves in the field form between opposite sides when the dimension between the sides is a multiple of a half-wavelength. The electric field is enhanced in the middle of this cavity while the magnetic field is enhanced at the sides. This effect is usually responsible for peaks in the susceptibility versus frequency profile in the UHF region, and is also a contributor to the reciprocal nature of susceptibility peaks corresponding with emission peaks. It is discussed further in section 8.3.3.

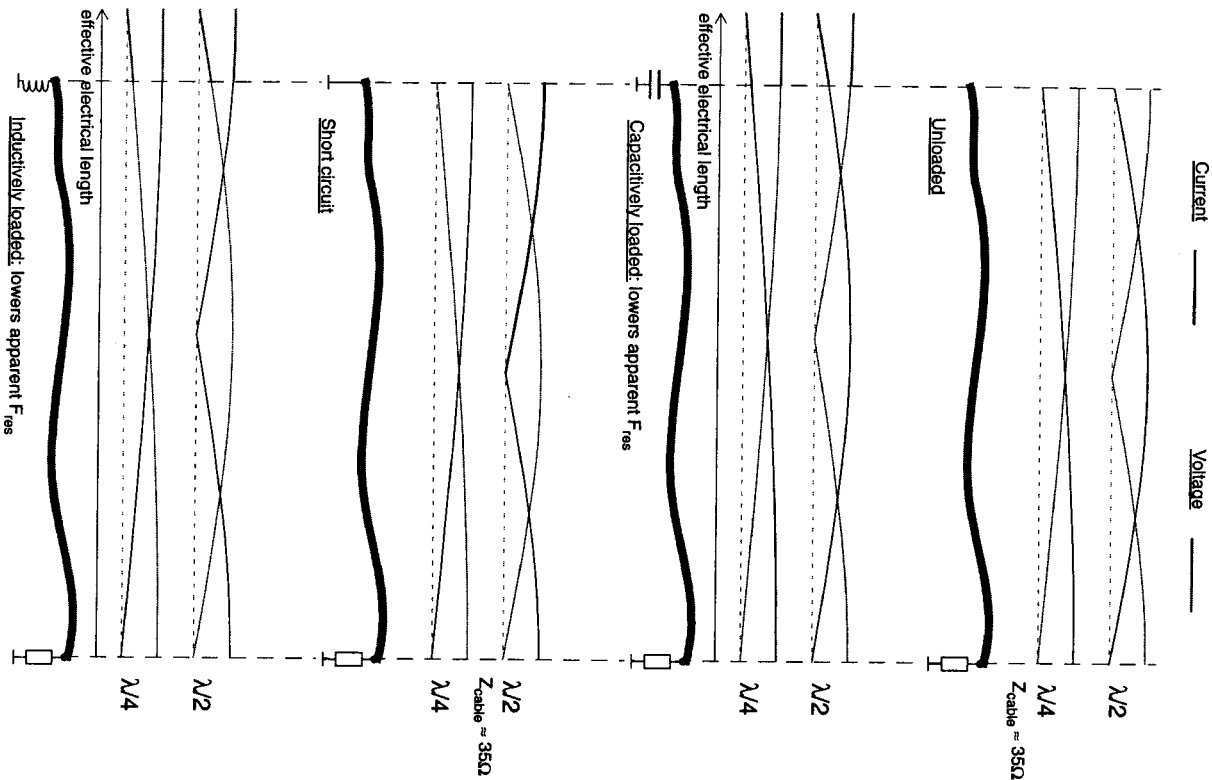

Figure 5.18 Current and voltage distribution along a resonant cable

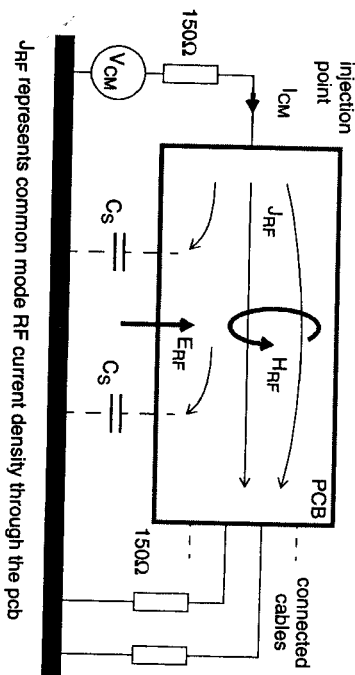

Figure 5.19 Common mode RF injection

5.3.2 Transients

Transient overvoltages occur on the mains supply leads due to switching operations, fault clearance or lightning strikes elsewhere on the network. Transients over 1kV account for about 0.1% of the total number of transients observed. A study by the German ZVEI [67] made a statistical survey of 28,000 live-to-earth transients exceeding 100V, at 40 locations over a total measuring time of about 3,400 hours. Their results were analysed for peak amplitude, rate of rise and energy content. Table 5.2 shows the average rate of occurrence of transients for four classes of location, and Figure 5.20 shows the relative number of transients as a function of maximum transient amplitude. This shows that the number of transients varies roughly in inverse proportion to the cube of peak voltage.

High energy transients may threaten active devices in the equipment power supply. Fast-rising edges are the most disruptive to circuit operation, since they are attenuated least by the coupling paths and they can generate large voltages in inductive ground and signal paths. The ZVEI study found that rate of rise increased roughly in proportion to the square root of peak voltage, being typically 3V/ns for 200V pulses and 10V/ns for 2kV pulses. Other field experience has shown that mechanical switching produces multiple transients (bursts) with risetimes as short as a few nanoseconds and peak amplitudes of several hundred volts. Attenuation through the mains network (see section 5.1.3) restricts fast risetime pulses to those generated locally.

Analogue circuits are almost immune to isolated short transients, whereas digital circuits are easily corrupted by them. As a general guide, microprocessor equipment should be tested to withstand pulses at least up to 2kV peak amplitude. Thresholds below 1kV will give unacceptably frequent corruptions in nearly all environments, while between 1kV–2kV occasional corruption will occur. For a belt-and-braces approach for high reliability equipment, a 4–6kV threshold is recommended.

5.3.2.1 Coupling mode

Mains transients may appear in differential mode (symmetrically between live and neutral) or common mode (asymmetrically between live/neutral and earth). Coupling between the conductors in a supply network tends to mix the two modes. Differential mode spikes are usually associated with relatively slow risetimes and high energy, and

Area Class	Average rate of occurrence (transients/hour)
Industrial	17.5
Business	2.8
Domestic	0.6
Laboratory	2.3

Table 5.2 Average rate of occurrence of mains transients

Sources:
 Transients in Low Voltage Supply Networks, J.J. Goedbloed, IEEE Transactions on Electromagnetic Compatibility, Vol EMC-29 No 2, May 1987, p 107
 Characterization of Transient and CW Disturbances Induced in Telephone Subscriber Lines, J.J. Goedbloed, W.A. Pasnoot, IEE 7th International Conference on EMC, York 1990

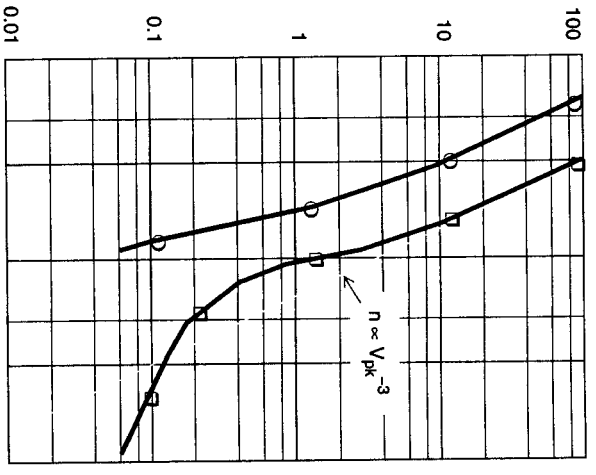

Figure 5.20 Relative number of transients (per cent) vs. maximum transient amplitude (volts) □ Mains lines (V_r 100V), ○ Telecomm lines (V_r 50V)

require suppression to prevent input circuit damage but do not, provided this suppression is incorporated, affect circuit operation significantly. Common mode transients are harder to suppress because they require connection of suppression components between live and earth, or in series with the earth lead, and because stray capacitances to earth are harder to control. Their coupling paths are very similar to those followed by common mode RF signals. Unfortunately, they are also more disruptive because they result in transient current flow in ground traces.

5.3.2.2 Spectral density and energy content

Transient interference is inherently broadband, and its frequency distribution is described by its amplitude spectral density: that is, the amplitude over a defined bandwidth versus frequency, expressed in volts per Hertz or volt-seconds. If the actual waveshape of a transient is known then the spectral density can be derived by taking the Fourier transform of this time domain waveform. In general of course the waveforms of real transients vary widely, but Figure 5.21 shows the spectral densities of the waveforms which have been standardized in the IEC 61000-4 series of immunity tests. If the frequency domain coupling transfer function is known even approximately, then the spectral density can be multiplied by this transfer function to work out the amplitude of an incoming transient at points of interest in the circuit [17].

The energy content of transients and surges is not simple to define. The actual energy available from the source is not all dissipated in the load. That proportion which

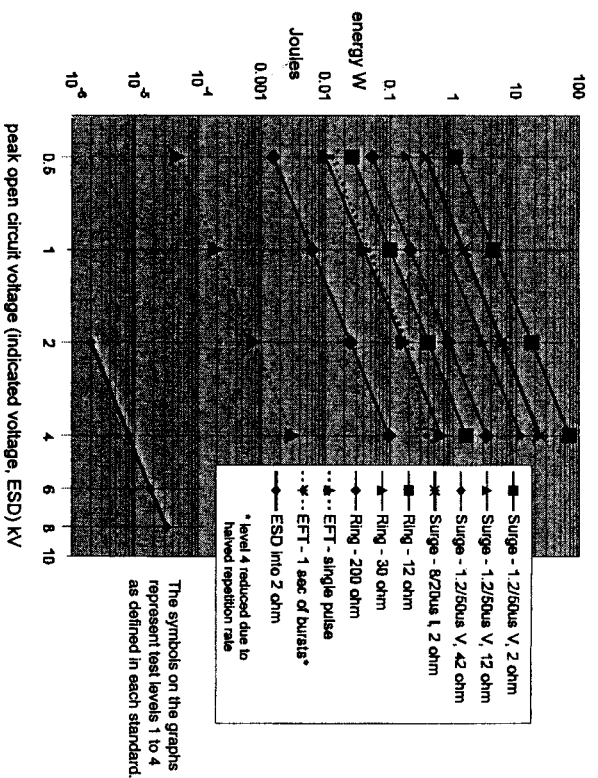

Figure 5.21 Amplitude spectral density and energy content

is, depends on the ratio of the load and source impedances. In general, a load such as a surge suppressor will be non-linear and will also have a time or frequency dependence. As an approximate indication of the energy content of a particular standard transient, the actual energy delivered by the generator into a defined resistive load can be calculated. For the ESD and EFT waveforms, these can be the calibration loads of 2Ω and 50Ω respectively. For the surge and ring waves, a load which matches the output impedance can be chosen, and the voltage or current waveform is delivered into this resistance with half the open circuit (or short circuit, for current) amplitude. In practice, of course, this doesn't happen since the load is not matched to the output

impedance. In these cases the energy in Joules (watt seconds) is shown in Figure 5.21 and is given by

$$W = \frac{1}{R} \int_0^T \left(\frac{V(t)}{2} \right)^2 dt \quad W = R \int_0^T \left(\frac{I(t)}{2} \right)^2 dt$$

where $V(t)$ and $I(t)$ are the open circuit voltage and short circuit current waveforms, respectively.

These graphs are for comparative purposes only – the real energy delivered to a particular EUT can only be calculated if the load impedance and characteristics, and the actual waveshape applied to this load, are known accurately.

5.3.2.3 Transients on signal lines

Fast transients can be coupled, usually capacitively, onto signal cables in common mode, especially if the cable passes close to or is routed alongside an impulsive interference source. Although such transients are generally lower in amplitude than mains-borne ones, they are coupled directly into the I/O ports of the circuit and therefore flow in the circuit ground traces, unless the cable is properly screened and terminated or the interface is properly filtered.

Other sources of conducted transients are telecommunication lines and the automotive 12V supply. The automotive environment can regularly experience transients that are many times the nominal supply range. The most serious automotive transients (Figure 5.22) are the load dump, which occurs when the alternator load is suddenly disconnected during heavy charging; switching of inductive loads, such as motors and solenoids; and alternator field decay, which generates a negative voltage spike when the ignition switch is turned off. ISO 7637 specifies transient testing in the automotive field.

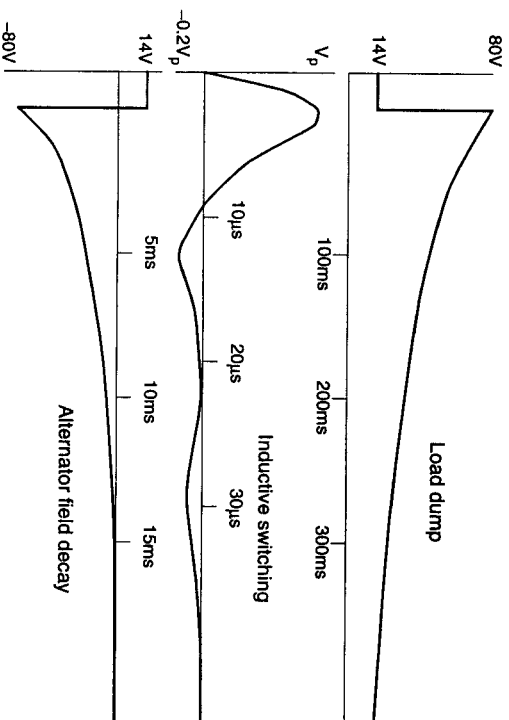

Figure 5.22 Automotive transients according to ISO 7637-1

Work on common mode transients on telephone subscriber lines [68] has shown that the amplitude versus rate of occurrence distribution also follows a roughly inverse cubic law as in Figure 5.20. Actual amplitudes were lower than those on the mains (peak amplitudes rarely exceeded 300V). A transient ringing frequency of 1MHz and rise times of 10–20ns were found to be typical. Telephone and data lines that enter a building from outside are particularly likely to be subject to lightning surges, and any ports that are connected to such lines should be designed to withstand such surges.

5.3.3 Electrostatic discharge

When two non-conductive materials are rubbed together or separated, electrons from one material are transferred to the other. This results in the accumulation of triboelectric charge on the surface of the material. The amount of the charge caused by movement of the materials is a function of the separation of the materials in the triboelectric series (Figure 5.23(a)) – positive materials give up electrons more readily, negative materials acquire them more readily. Additional factors are the closeness and area of contact, and rate of separation.

The voltage to which an object can be charged depends on its capacitance, following the law $Q = CV$. The human body can be charged by triboelectric induction to several kV. Because a perfect insulator does not allow movement of electrons, surface charges on an insulator remain in the area within which they were generated, but the human body is conductive and so a triboelectrically induced charge distributes itself over the body. The rate at which charge will bleed off a body to its surroundings, and so become neutralized, depends on the surface resistivity of the body and its surroundings. This in turn is a function of relative humidity: The more moisture there is in the air, the lower the surface resistivity of insulators and hence the quicker that charges bleed away. In practice, since movement is constantly generating charge, there is a balance between generation and dissipation which results in a typical level of charge voltage that can be found in a particular environment (Figure 5.23(b)).

When the body (in the worst case, holding a metal object such as a key) approaches a conductive object, the charge is transferred to that object normally via a spark, when the potential gradient across the narrowing air gap is high enough to cause breakdown. The energy involved in the charge transfer may be low enough to be imperceptible to the subject; at the other extreme it can be extremely painful. It is not essential that the target object is grounded. Charge transfer can occur between any two capacitive objects as long as there is a static potential difference between them, and a disruptive discharge current pulse will flow.

5.3.3.1 The ESD waveform

When an electrostatically charged object is brought close to a grounded target the resultant discharge current consists of a very fast (sub-nanosecond) edge followed by a comparatively slow bulk discharge curve. The characteristic of the hand/metal ESD current waveform is a function of the approach speed, the voltage, the geometry of the electrode and the relative humidity. The equivalent circuit for such a situation is shown in Figure 5.23(c). The capacitance C_D (typically 150pF for the human body) is charged via a high resistance up to the electrostatic voltage V . The actual value of V will vary as the charging and leakage paths change with the environmental circumstances and movements of the subject. When a discharge is initiated, the free space capacitance C_s , which is directly across the discharge point, produces an initial current peak the value

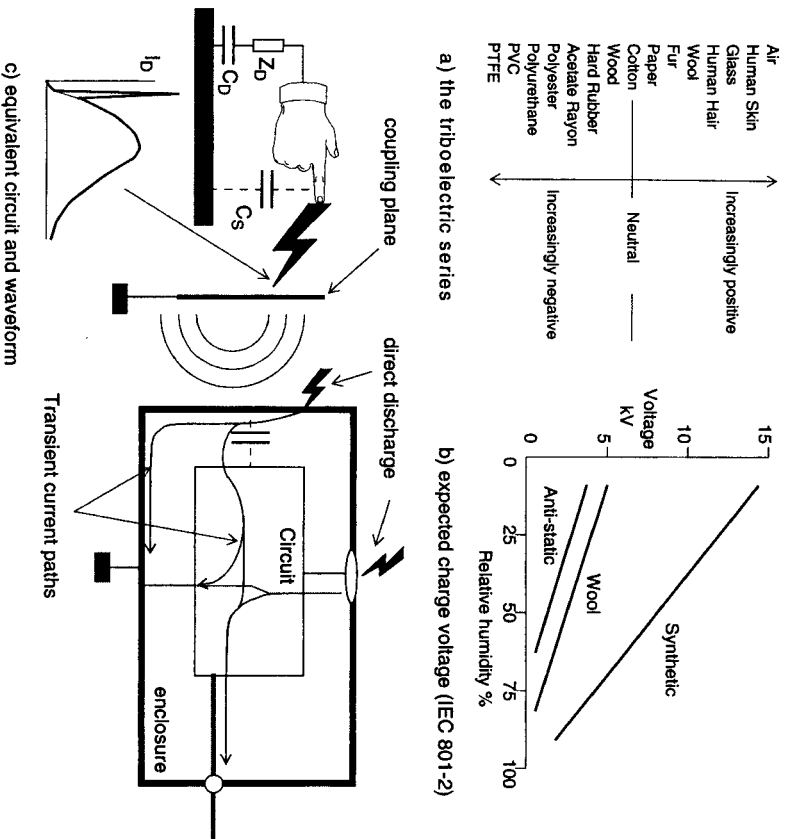

Figure 5.23 The electrostatic discharge

of which is only limited by the local circuit stray impedance, while the main discharge current is limited by the body's bulk inductance and resistance Z_D .

The principal effects of an ESD in terms of equipment malfunction are produced by the discharge current pulse di/dt and its indirect effects. The rate of change of electric field dE/dt when the local static charge voltage collapses can also couple capacitively into high impedance circuits, and in some circumstances the high static electric field itself, before a discharge happens, may cause undesirable effects.

5.3.3.2 Coupling paths

The resultant sub-nanosecond transient equalizing current of several tens of amps follows a complex route to ground through the equipment and is very likely to upset digital circuit operation if it passes through the circuit tracks. The paths are defined more by stray capacitance, case bonding and track or wiring inductance than by the designer's intended circuit. The high magnetic field associated with the current can induce transient voltages in nearby conductors that are not actually in the path of the current. Even if not discharged directly to the equipment, a nearby discharge such as to a metal desk or chair will generate an intense radiated field which will couple into unprotected equipment.

Critical areas which can act as sink points for the ESD are exposed metalwork, apertures, front panel components and connectors. Components and apertures can allow a discharge to take place via creepage across a surface to the circuits inside an enclosure, even if the enclosure itself is insulating. The breakdown voltage gradient in dry air is approximately 30kV per cm but this is reduced considerably across a surface, especially if the surface is contaminated with dirt or other substances.

5.3.3.3 Secondary discharge

A common problem arises when a product enclosure is connected externally to ground at a different point and via a different route than the internal circuit. Because of the inductance of the various connections, a transient voltage will appear inside the enclosure, between the enclosure and the circuit (Figure 5.24). This voltage can then cause a secondary discharge to occur at unpredictable points inside the enclosure, which can be much more damaging and disruptive than the source discharge, since there is a lower impedance to limit the current, and also because a higher induced voltage occurs on a PCB track when an ESD occurs within a resonant structure. To prevent this, it is essential to bond the enclosure and the circuit board together at a suitable point, typically at an interface ground (see section 6.2.3).

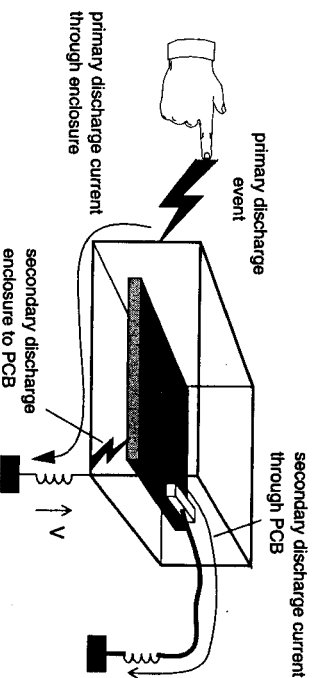

Figure 5.24 The cause of secondary discharge

5.3.4 LF magnetic fields

Magnetic fields at low frequencies can induce interference voltages in closed wiring loops, their magnitude depending on the area that is intersected by the magnetic field. Non-toroidal mains transformers and switch-mode supply transformers are prolific sources of such fields and they will readily interfere with sensitive circuitry or components within the same equipment. Any other equipment needs to be immune to the proximity of such sources. Particular environments may result in high low-frequency or dc magnetic field strengths, such as electrolysis plant where very high currents are used, or certain medical apparatus.

50Hz currents in supply conductors are typical sources of magnetic fields. If the currents in a cable are balanced, i.e. the cable carries live and neutral together or all three phases together, then at a distance the magnetic fields from each conductor cancel and the net field is near zero. Close in to the cable though, the fields do not cancel perfectly since their source conductors are located at slightly different positions. The fields also will not cancel if the currents are not balanced, i.e. if there is some return

path outside the cable – this is the same situation as was discussed earlier in section 5.1.5.2 for common mode current flow.

The flux density at a distance r metre at right angles to a single long conductor carrying a current I amps is given by

$$B = (0.2 \cdot I/r) \text{ microtesla} \quad (5.13)$$

To find the field at a distance from a group of conductors, as in a cable, each carrying current of a particular phase and amplitude, it is only necessary to calculate the appropriate geometry and perform a vector sum of the field contributions from each conductor. A threshold value of $1\mu\text{T}$ is often recommended as a level below which an installation is acceptable [85].

The voltage developed by an external magnetic field in a single turn loop is:

$$V = A \cdot \text{dB/dt} \quad (5.14)$$

where A is the loop area in m^2 and

B is the flux density normal to the plane of the loop in Tesla

It is rare for such fields to affect digital or large signal analogue circuits, but they can be troublesome with low level circuits where the interference is within the operating bandwidth, such as audio or precision instrumentation. Specialized devices which are affected by magnetic fields, such as photomultiplier or cathode ray tubes, may also be susceptible.

5.3.4.1 Magnetic field screening

Conventional screening is ineffective against LF magnetic fields, because it relies on reflection rather than absorption of the field. Due to the low source impedance of magnetic fields reflection loss is low. Since it is only the component of flux normal to the loop which induces a voltage, changing the relative orientation of source and loop may be effective. LF magnetic shielding is only possible with materials which exhibit a high absorption loss such as steel, mu-metal or permalloy. As the frequency rises these materials lose their permeability and hence shielding efficiency, while non-magnetic materials such as copper or aluminium become more effective. Around 100kHz shielding efficiencies are about equal. Permeable metals are also saturated by high field strengths, and are prone to lose their permeability through handling. See section 8.3.2 on page 295 for more discussion.

5.3.5 Supply voltage phenomena

Low frequency disturbances on the mains supply are covered in some detail in IEC61000 part 2 sections 1 and 2. Section 1 [147] describes the environment, i.e. the nature of the disturbances that can be expected on public mains supplies, while section 2 [148] gives compatibility levels, i.e. the levels of disturbances that can be expected. The phenomena considered are:

- harmonics and inter-harmonics
- voltage fluctuations, dips and short supply interruptions
- voltage unbalance in three-phase supplies
- mains signalling
- power frequency variation

Harmonics are considered further in section 5.4.

Brown-outs (voltage dips) and interruptions are a feature of all mains distribution networks, and are usually due to fault clearing or load switching elsewhere in the system (Figure 5.25). Such events will not be perceived by ordinary electronic equipment if its input reservoir hold-up time is sufficient, but if this is not the case then restarts and output transients can be experienced. Thyristor inverters may experience commutation failure and synchronous devices may lose synchronism. Typically, interruptions (as opposed to power cuts) can last for 10–500ms.

Load and line voltage fluctuations are maintained between +10% and –15% of the nominal line voltage in most industrialized countries. As a result of HD472/BS7697 [161], the EU countries are moving towards 230V $\pm 10\%$ at the point of connection to the consumer. Between 1995 and 1st January 2003, countries with a previously declared nominal voltage of 240V will have a range of 230V +10% –6%, and those with a previous voltage of 220V will have a range of 230V +6% –10%. Slow changes in the voltage within these limits occur on a diurnal pattern as the load on the power system varies. The declared voltage does not include voltage drops within the customer's premises, and so you should design stabilized power supplies to meet at least the –15% limit.

Dips exceeding 10% of nominal voltage occur up to 4 times per month for urban consumers and more frequently in rural areas where the supply is via overhead lines [75][148]. Note that much wider voltage (and frequency) fluctuations and more frequent interruptions are common in those countries which do not have a well-developed supply network. They are also common on supplies which are derived from small generators.

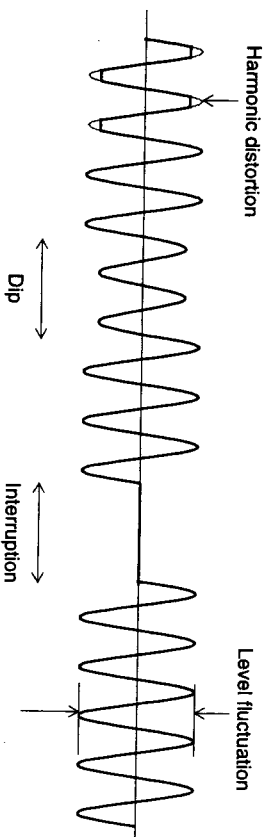

Figure 5.25 Mains supply fluctuations

Heavy industrial loads such as resistance and arc welding machines, large motors and arc furnaces can cause short-term step or random fluctuations and can affect many consumers fed from the same source. The main effect of these disturbances is flicker of lamp loads, which can cause physiological discomfort. Electronic power supply circuits can normally be designed to ignore them, although other circuits which use the 50Hz signal (e.g. for timing or phase reference) should have their operating bandwidth severely restricted by a 50Hz bandpass filter to ensure immunity from low-amplitude step changes.

5.4 Mains harmonics

One EMC phenomenon, which comes under the umbrella of the EMC Directive and is usually classified as an "emission", is the harmonic content of the mains input current. This is mildly confusing since the equipment is not actually "emitting" anything; it simply draws its power at harmonics of the line frequency as well as at the fundamental.

5.4.1 The supplier's problem

The problem of mains harmonics is principally one for the supply authorities, who are mandated to provide a high quality electricity supply. If the aggregate load at a particular mains distribution point has a high harmonic content, the non-zero distribution source impedance will cause distortion of the voltage waveform at this point, and possibly, due to supply network resonances, at other remote points. This in turn may cause problems for other users, and the currents themselves may also create problems (such as overheating of transformers and compensating components) for the supplier. The supplier does of course have the option of uprating the distribution components or installing special protection measures, but this is expensive and the supplier has room to argue that the users should bear some of the costs of the pollution they create.

Throughout the last few decades, harmonic pollution has been increasing and it has been principally due to low power electronic loads installed in large numbers. Between them, domestic TV sets and office information technology equipment account for about 80% of the problem. Other types of load which also take significant harmonic currents are not widely enough distributed to cause a serious problem yet, or are dealt with individually at the point of installation as in the case of industrial plant. The supply authorities are nevertheless sufficiently worried to want to extend harmonic emission limits to all classes of electronic products.

IEC 61000-2-2 defines the compatibility level in terms of total harmonic distortion factor as 8% THD.

5.4.2 Non-linear loads

A plain resistive load across the mains draws current only at the fundamental frequency (50Hz in Europe). Most electronic circuits are anything but resistive. The universal rectifier-capacitor input draws a high current at the peak of the voltage waveform and zero current at other times; the well known triac phase control method for power control (lights, motors, heaters etc.) begins to draw current only partway through each half cycle. These current waveforms can be represented as a Fourier series, and it is the harmonic amplitudes of the series that are subject to regulation.

The standard which covers mains harmonics is IEC 61000-3-2, published in 1995. Its requirements are detailed in section 3.2 where you will see that it applies either fixed limits to the harmonic content up to 2KHz (40th harmonic) or variable limits depending on the power drawn by the equipment; choice of limits depends on the class of product.

The limits are effectively an additional design constraint on the values of the input components, most notably the input series impedance (which is not usually considered as a desirable input component at all). Figure 5.26(a), which is a Fourier analysis of the current waveform calculated in the time domain, shows the harmonic content of input current for a rectifier-reservoir combination with a fairly high series resistance. This value of series resistance would not normally be found except with very inefficient transformer-input supplies. The fifth harmonic content just manages to meet Class D.

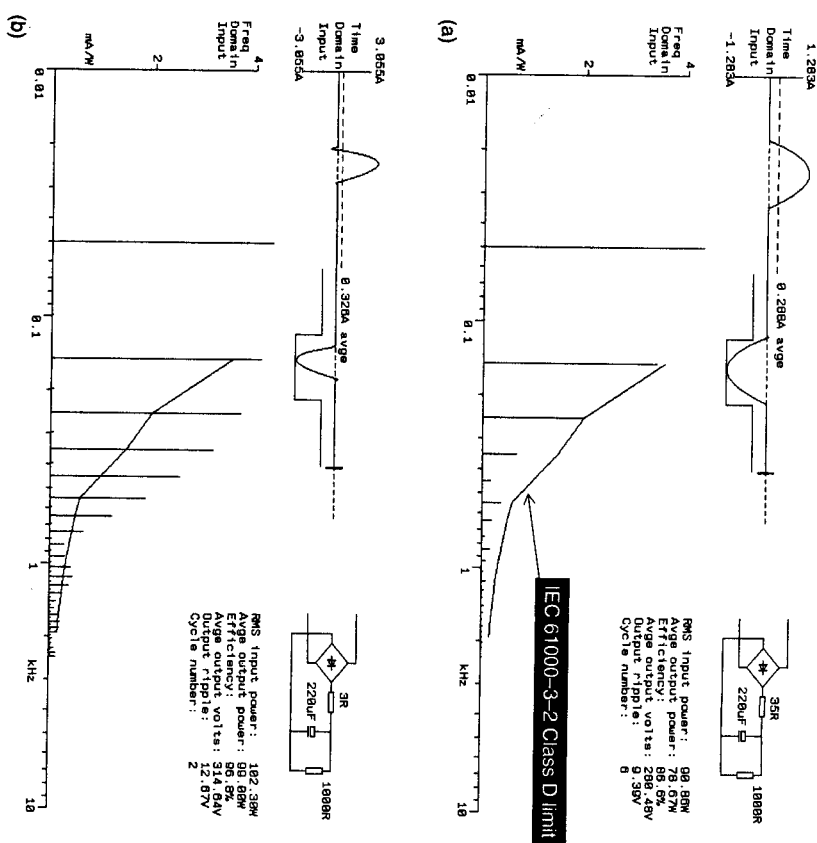

Figure 5.26 Mains input current harmonics for rectifier-reservoir circuit

5.4.2.1 The effect of series resistance

Figure 5.26(b) illustrates the difference in input harmonics resulting from a tenfold reduction in input resistance. This level of input resistance would be typical for a direct-off-line switching supply and many highly efficient supplies could boast a lower R_s . The peak input current has increased markedly while its duty cycle has shrunk, leading to a much higher crest factor (ratio of peak to root mean square current) and thus higher levels of harmonics.

Increasing input series resistance to meet the harmonic limits is expensive in terms of power dissipation except at very low powers. In practice, deliberately dissipating between 10 and 20% of the input power rapidly becomes unreasonable above levels of 50-100W. In fact, the requirements of IEC 61000-3-2 do not apply to equipment having an active input power below 75W. Alternatives are to include a series input choke, which since it must operate down to 150Hz at the full input current is expensive in size and weight; or to include electronic power factor correction (PFC), which

converts the current waveform to a near-sinusoid but is expensive in cost and complexity.

5.4.2.2 Power factor correction

PFC is essentially a switchmode converter on the front-end of the supply and therefore is likely to contribute extra RF switching noise at the same time as it reduces input current harmonics. It is possible to combine PFC with the other features of a direct-off-line switching supply, so that if you are intending to use a SMPS anyway there will be little extra penalty. It also fits well with other contemporary design requirements such as the need for a "universal" (90-260V) input voltage range. Such power supplies can already be bought off-the-shelf, but unless you are a power supply specialist, to design a PFC-SMPS yourself could take considerable extra design and development effort. The availability of special-purpose control ICs makes the task easier.

Figure 5.27 shows the basis of operation of a power factor correction circuit. Instead of an input rectifier/reservoir combination, the rectified input feeds a switchmode boost converter circuit directly whose operational input voltage range extends from near-zero to the peak supply voltage. The pulse width of the switching circuit is regulated to give an average input current which approximates to the required sinusoidal waveshape. The effective distortion is very low, and therefore so is the harmonic content.

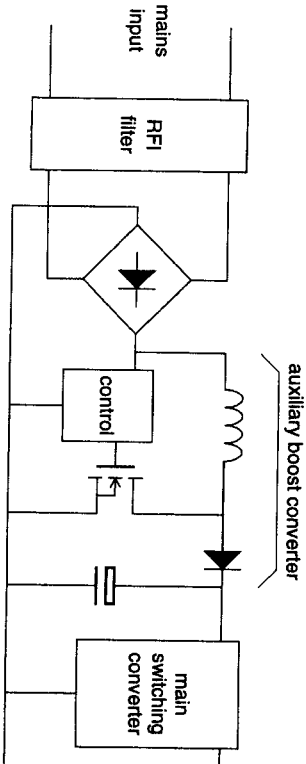

Figure 5.27 Schematic of a switchmode PFC circuit

5.4.2.3 Phase control

Power control circuits which vary the switch-on point with the phase of the mains waveform are another major source of harmonic distortion on the input current. Lighting controllers are the leading example of these. Figure 5.28 shows the harmonic content of such a waveform switched at 90° (the peak of the cycle, corresponding to half power). The maximum harmonic content occurs at this point, decreasing as the phase is varied either side of 90°. Lighting dimmers without input filtering or PFC of greater than about 5A rating are outlawed, since the limits are set at an absolute value.

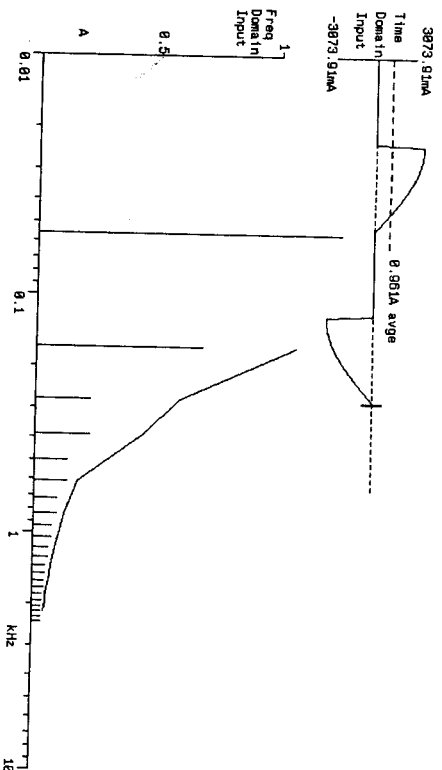

Figure 5.28 Mains input current harmonics for 500W phase control circuit at half power