Digitally Addressable DALI Dimming Ballast

*Authors: Ross Fosler
Microchip Technology Incorporated
Cecilia Contenti
International Rectifier
Tom Ribarich
International Rectifier*

INTRODUCTION

This reference design is a high efficiency, high power factor and digital dimming electronic ballast designed to drive rapid start fluorescent lamp types. The design contains an active power factor correction circuit for universal voltage input as well as a ballast control circuit using the IR2159. The design also includes a PIC16F628 microcontroller and an isolation circuit for connecting to a Digitally Addressable Lighting Interface (DALI). Other features include EMI filtering, transient protection and lamp FAULT protection.

International Rectifier (IR) and Microchip Technology Inc. worked together to design a DALI type ballast. An application note is provided here, and the corresponding reference design is available from IR (see page 10 for ordering information).

This document describes many of the details within the design of the ballast and some of the basics to DALI. However, this document does not describe all the details contained within the DALI specification. The reader should be familiar with DALI and international standard EN60929.

FIGURE 1: DALI DIMMING BALLAST

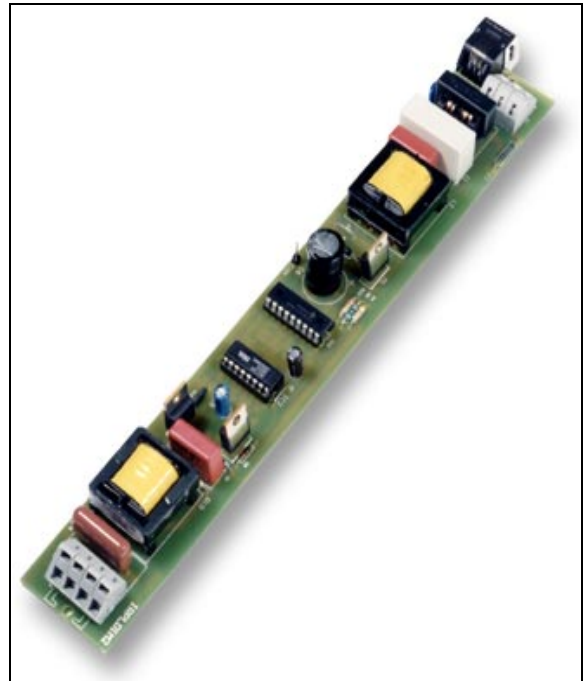

Features

- Lamp Type: 1X 36W T8 Lamp (IRPLDIM2E)
- 1X 32W T8 Lamp (IRPLDIM2U)
- Line Input: 185-265 VAC/50Hz (IRPLDIM2E)
- 90-140 VAC/60Hz (IRPLDIM2U)
- Interface DALI (2 wires)
- High Power Factor/Low THD
- High Frequency Operation
- Programmable Lamp Filament Preheating
- Programmable Ignition
- High precision Digital Dimming
- Logarithmic Dimming
- Diagnostic and FAULT Control
- Lamp FAULT Protection
- Brown-out Protection
- IR2159 HVIC Ballast Controller
- PIC16F628 Microcontroller
- Optically Isolated Communications
- Low Power Standby Mode

Digitally Addressable Lighting Interface (DALI)

The Digital Addressable Lighting Interface (DALI), international standard prIEC929 is a communication protocol and method to interface lighting units on a 2-wire network. The DALI protocol is 16 bits and supports addressing up to 64 ballasts individually, 16 groups, or broadcasting to the entire lighting network. Aside from the protocol, DALI supports fading, logarithmic dimming, scenes, and FAULT detection.

The DALI allows a complete lighting environment to be controlled and managed efficiently. The DALI can control (transmit and receive) up to 64 different ballasts with the same control system, transmitting instructions to single ballasts or to a group of ballasts. The ballast

provides eye sensitive dimming over a wide range (1-100%). Various operating parameters can be changed and stored dynamically within the ballast memory. For example, scene levels can be set for different groups of ballast. In addition, maximum brightness, minimum brightness, fade-time, and several other features can be set as desired. Another feature is the ability to diagnose problems such as lamp failures.

Perfect Light Quality

By means of digital control, the light level can be adjusted according to individual lighting needs. The DALI includes 256 levels of brightness and a logarithmic dimming curve (Figure 2). The use of this curve allows for better control at lower light levels where the human eye is more sensitive.

FIGURE 2: DIMMING CHARACTERISTICS

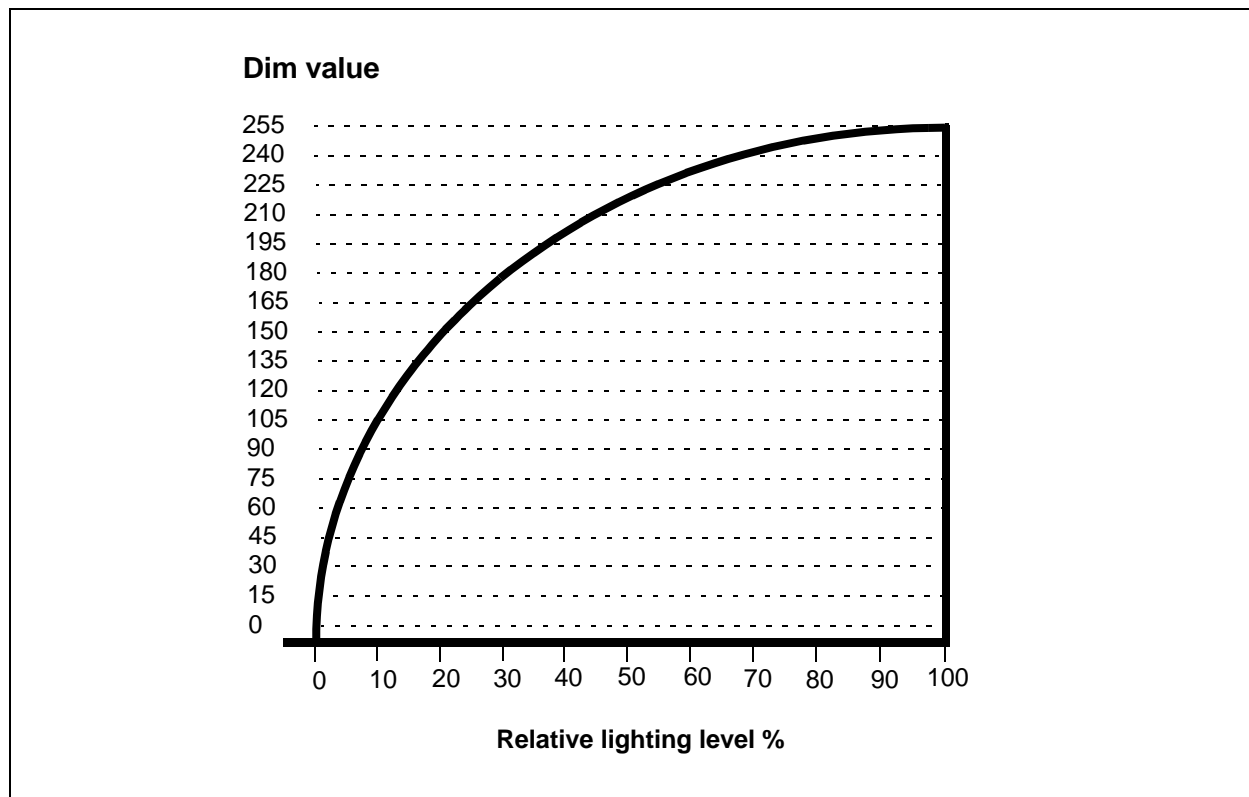

FUNCTIONAL DESCRIPTION

The IRPLDIM2 Demo Board consists of an EMI filter, an active power factor correction front end, a ballast control section, a digital control section, and a resonant lamp output stage. A block diagram of the design is shown in Figure 3.

The EMI filter blocks ballast generated noise. The power factor correction is used for sinusoidal input current and a regulated DC bus. The ballast control section provides frequency modulation control of a traditional RLC lamp resonant output circuit for preheating, igniting and ballasting the lamp. It is easily adaptable to a wide variety of lamp types. The digital control section provides the DALI and the necessary circuitry and software to perform closed-loop dimming, lamp FAULT detection, shutdown and auto restart

You can connect the board directly to the DALI input (two connections) or you can use the RS-232/DALI converter board (for demo purposes with the IRPLDIM2 board) to connect it to the PC.

The ballast control circuit uses the IR2159 Dimming Ballast Control IC programmed by the PIC16F628 microcontroller. The IR2159 controls the ballast according to the signals received from the microcontroller. The microcontroller is connected to the ballast and the IC to receive diagnostic signals.

The communication between the ballast and the external world is done with two signals: TX (digital serial signal transmitted from the network to the microcontroller) and RX (digital serial signal from the microcontroller to the network). This system allows the ballast to communicate bi-directionally with the network (a PC or generally a DALI system). A digital interface assures high voltage isolation between DALI inputs and the resonant lamp output stage. The microcontroller manages the communication between interface and ballast IC.

The complete circuit is shown in Appendix A. In the circuit, thick traces represent high frequency and high current paths. Lead lengths should be minimized to avoid high-frequency noise problems. Appendix B lists the Bill of Materials.

Power Factor Control

The power factor correction section consists of a Power Factor Controller IC (IC1), MOSFET (M1), inductor (L2), diode (D2), capacitor (C6) and additional biasing and sensing and compensation components (see Appendix A). The power factor correction circuit is a boost converter type running in Critical Conduction mode. This means that the inductor current discharges to zero each cycle before the boost MOSFET is turned on. The ST L6561D PFC IC is used, which shapes the input current to the input voltage while regulating the DC bus voltage at 400 V_{DC}. The IC is chosen for its minimal component count, low start-up supply current, and robust error amplifier.

Ballast Control

The ballast control section is built around the IR2159 Dimming Ballast Control IC (IC2). The IR2159 is used for preheating and igniting the lamp, controlling the lamp power and detecting FAULT condition (over temperature, over current, V_{CC} FAULT, and DC Bus/AC line FAULT). The IR2159 contains a voltage-controlled oscillator (VCO) which controls the half-bridge frequency while maintaining a 50% duty cycle, a high voltage half-bridge driver, an amplitude control, FAULT circuit and an analog dimming interface.

To preheat the lamp, the amplitude control feature of the IR2159 is used. This regulates the resonant tank current during the Preheat period. The VCO starts at maximum frequency then decreases the frequency until the voltage at the CS pin is equal to the programmed voltage at the IPH pin. Then, the VCO is adjusted internally (and therefore the frequency) such that the inductor current remains constant until the external capacitor on pin CPH charges above 5.1V. The preheat current (voltage) can be adjusted by increasing or decreasing the resistor on the IPH pin (RIPH) and the preheat time can be adjusted by increasing or decreasing the capacitor on pin CPH (CCPH).

When pin CPH exceeds 5.1V, the IR2159 enables the over-current protection and the next cycle where the CS pin exceeds the internal threshold of 1.6V the half-bridge is disabled. The VCO voltage decreases to a minimum value and the IR2159 starts to decrease the frequency to a minimum frequency which is set by the external resistor on pin FMIN (RFMIN) and the current sensing resistor, RCS. In this way, it generates a high voltage for igniting the lamp. This voltage can be varied by adjusting the RCS.

When the lamp is successfully ignited, the IR2159 aligns the phase angle of the inductor current with respect to the half bridge voltage to regulate the lamp power. This is done by measuring the zero crossing of the current and regulating it against the reference angle from the dimming interface. The IR2159 provides a 0-to-5 V_{DC} dimming interface, which converts the analog input voltage to an internal phase angle reference for controlling the lamp power. The DIM pin is a high impedance analog control input and the R_{MAX} and R_{MIN} pins set the maximum and minimum angle boundaries. The R_{MIN} resistor sets the minimum lamp power at 1% when V_{DIM}=0V and the R_{MAX} resistor sets the maximum lamp power at 100% when V_{DIM}=5V.

FIGURE 3: IRPLDIM2 BLOCK DIAGRAM

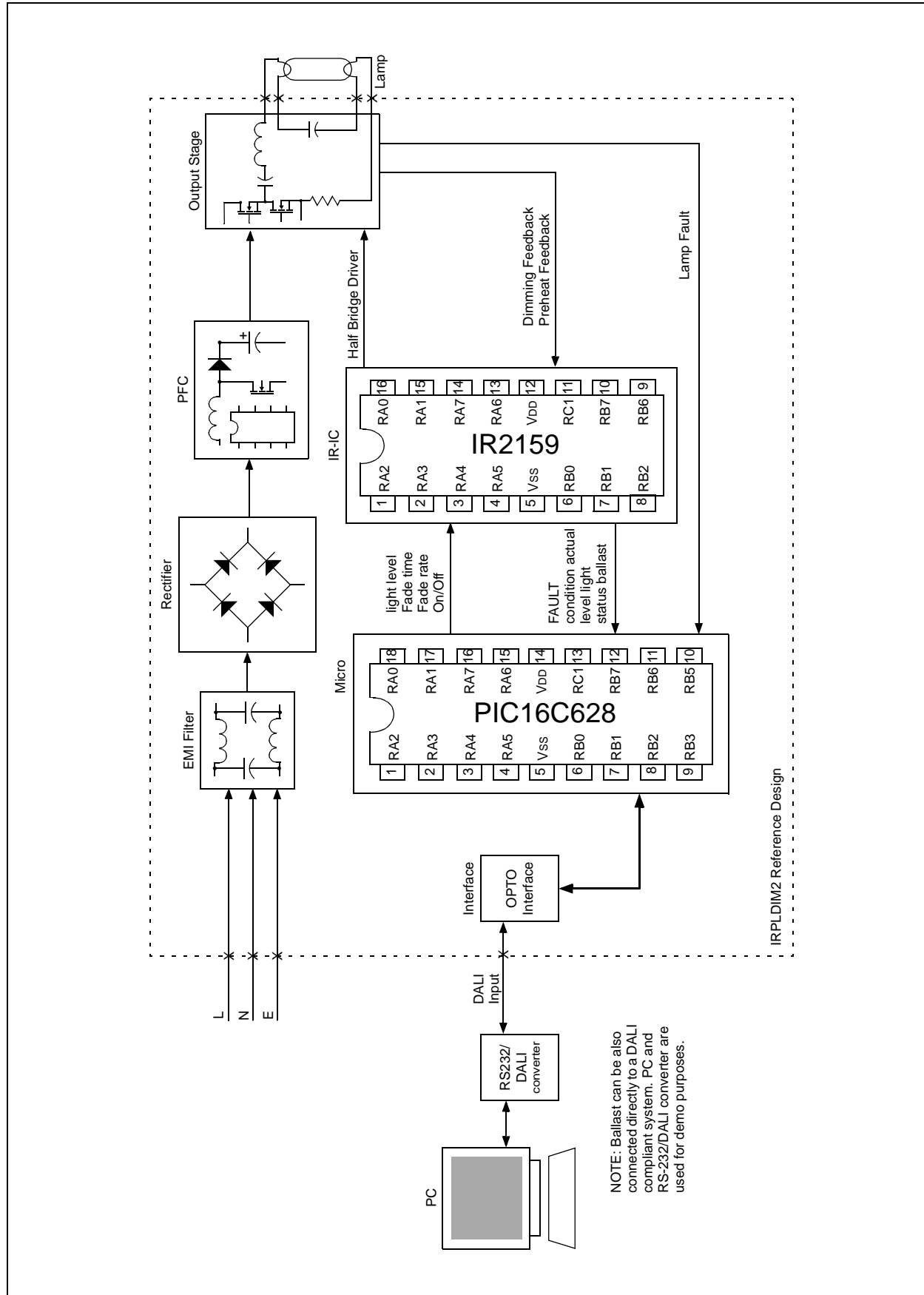

Digital Control

The digital control section is built around the Microchip PIC16F628 microcontroller. This microcontroller acts as an interface between the IR2159 ballast controller and the DALI. Data is transmitted to the unit and the PIC16F628 collects the data through an isolation circuit. The PIC16F628 then interprets the data and sends the appropriate signals to the ballast controller, IR2159 as necessary or sends information back to the DALI. The PIC16F628 also performs FAULT detection and disables the IR2159, if a FAULT is present.

BALLAST DESIGN

The ballast design incorporates two parts, hardware and software. The ballast controller design portion incorporates most of the hardware design. The digital design control portion incorporates most of the software design. Appendix A shows the complete schematic and Appendix B lists the Bill of Materials.

The Ballast Controller Design

The design of the ballast control portion of the circuit has been accomplished in International Rectifier's Reference Design IRPLDIM1. Refer to this for waveforms and specific calculations regarding the ballast controller portion of this design.

Signals of the IR2159

The communication between the microcontroller and the IR2159 is done with four signals, as shown in Figure 4. These signals are used for digital dimming (RB3), turning the ballast on or off (RB4) and FAULT detection (RB5 and RB6). The microcontroller controls the IR2159 by the following three pins: pins SD for shutdown of the IC (active high), FMIN used for FAULT detection (0 if the IC is in FAULT mode) and DIM to control the brightness. The microcontroller receives lamp information by the signal LAMP_OUT, connected to the lamp.

The shutdown signal (RB4) enables or disables the IR2159. When high, the lamp is off and the IR2159 is disabled with minimal current flowing. When low, the lamp is on. The PIC16F628 has control of this line and determines if lamp should be on or off based on FAULT conditions and user requested settings from the DALI.

FIGURE 4: MICROCONTROLLER / IR2159 COMMUNICATION

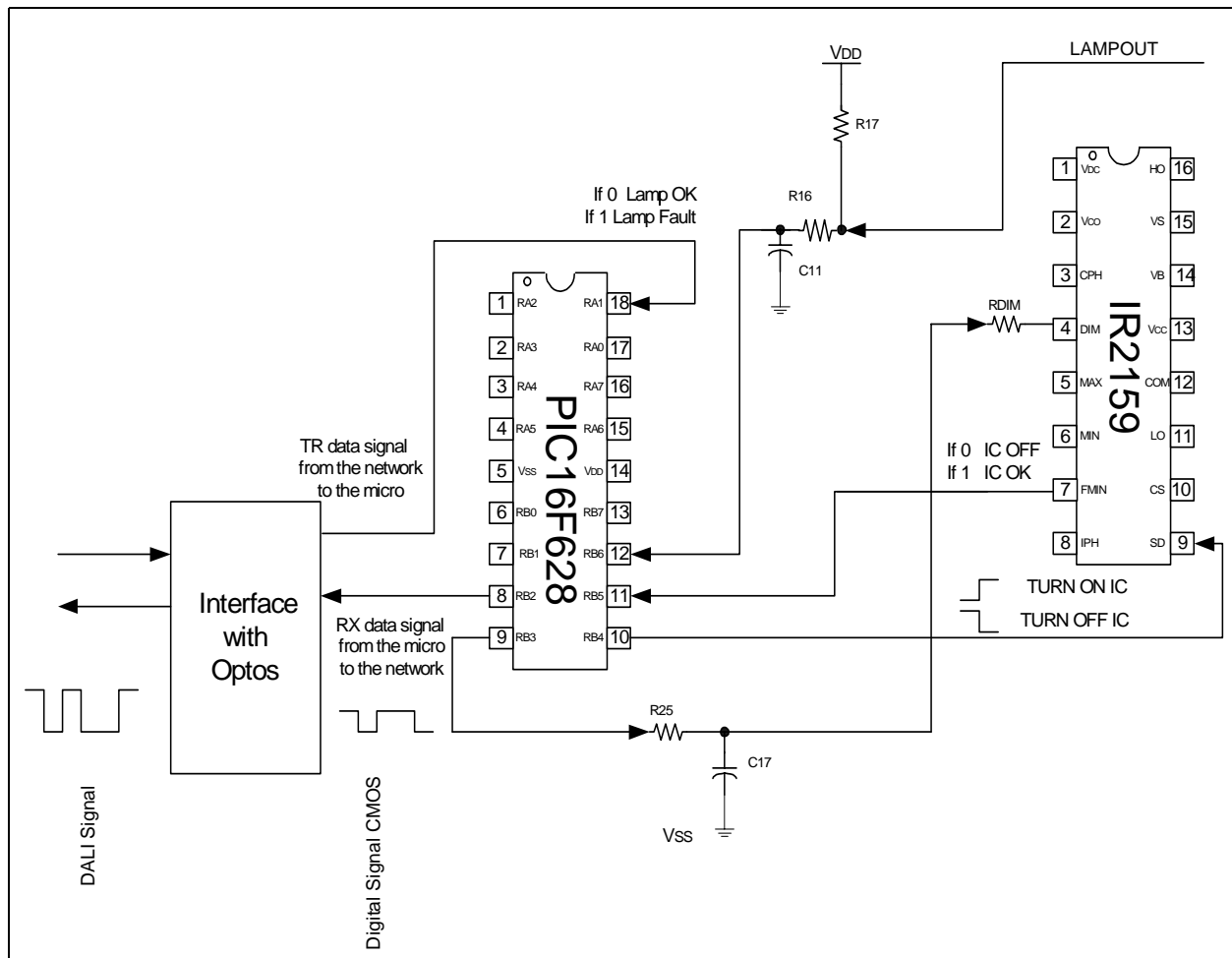

There are two signals used for FAULT detection, LAMP_OUT (RB6), and FAULT (RB5). The LAMP_OUT signal indicates the presence of a lamp or lamp FAULT. When the lamp is removed the LAMP_OUT signal is pulled up to V_{DD} by the pull-up resistor R17 and the software forces the IR2159 to shutdown. When the lamp is changed, this pin goes to 0V, the microcontroller turns the IR2159 on again, and the lamp restarts automatically. Other FAULT conditions are indicated by the FAULT signal (pin FMIN of the IR2159). A low on the FAULT signal indicates that the IR2159 is in a FAULT state. The IR2159 turns off automatically in FAULT conditions such as V_{CC} FAULT, over-current, failure to strike or low AC line and will remain in this FAULT state until the IC is RESET.

The IR2159 requires a 0.5 to 5V analog voltage (in pin DIM) to perform dimming, thus 0.5V corresponds to the 1% arc power level and 5V corresponds to the 100% arc power level. The PIC16F628 provides a pulse width modulated signal on pin RB3 that is filtered with a single RC network (R25 and C17). This provides an analog voltage for dimming. The microcontroller can change the dim voltage from 0.5 to 5V by changing the duty cycle and therefore generate 256 different voltage levels for the IR2159. To conform to the digital dimming requirements, the output is logarithmic rather than linear. Since the human eye is much more sensitive to lower light levels than high levels, the logarithmic output appears to be linear. Therefore, the PIC16F628 is programmed to produce a logarithmic voltage and the IR2159 drives the lamp arc power (Figure 5).

FIGURE 5: DIMMING CHARACTERISTICS

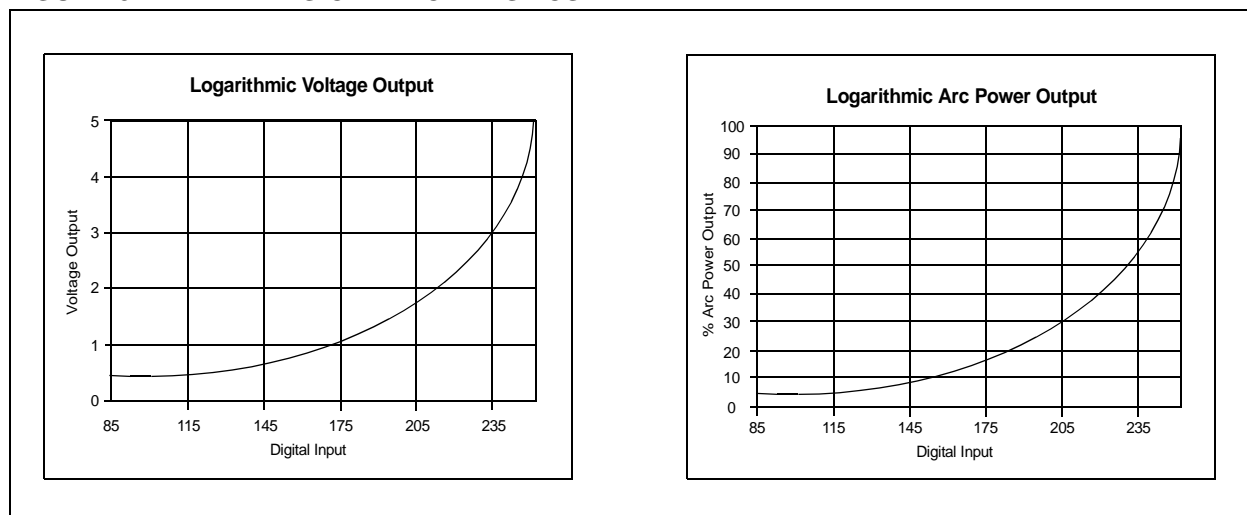

The Software

The software to implement the DALI is quite large yet simple to understand when broken into some elementary functional blocks. Figure 6 outlines the basic flow of the software in its most simplified form (the detail source code is available on a CD enclosed with the Reference Design Kit - see page 10 for ordering information).

Upon entry into the program after setup, the microcontroller is held in a loop. While in this loop, the microcontroller is checking for errors and it is polling the communications circuitry for incoming data. If valid data is received, it is filtered to determine if the address matches the defined address for the ballast, if the group matches the defined group memberships, or if the data is a broadcast command. In addition, the type of command is filtered into two basic choices, standard or special. Once filtered, the program immediately vectors to the appropriate command and executes. All of the commands are divided into four general categories including arc power control commands, configuration

commands, query commands, and special commands. Within each category, the commands are divided again according to related functions.

The arc power control commands are the most commonly used in a functioning lighting system. Within any of these commands, appropriate signals are sent to the ballast controller to adjust light level via pulse width modulation. This includes scene level selections. In addition, many of the commands in this group select the shutdown bit, depending on the definition of the command.

Configuration type commands are used to setup the ballast. Examples of such settings include setting minimum and maximum lighting thresholds, fade times and rates, groups, and scene levels. Generally, data is stored in an EEPROM storage area where it is maintained regardless of the power conditions.

Query type commands are used to get feedback from the ballast. All of the settings can be queried. Even more useful, the status of the ballast is available. Information about fading, the lamp, general FAULTS, and power is available through the appropriate query command.

Special type commands are unique compared to all other commands. These commands are immune to addresses; thus, all ballasts on the DALI respond to a special command. All the functions for finding new ballasts or ballasts that have no addresses are available. Uploading information to the ballast, typically settings, is also available in the special command set.

FIGURE 6: PROGRAM FLOW

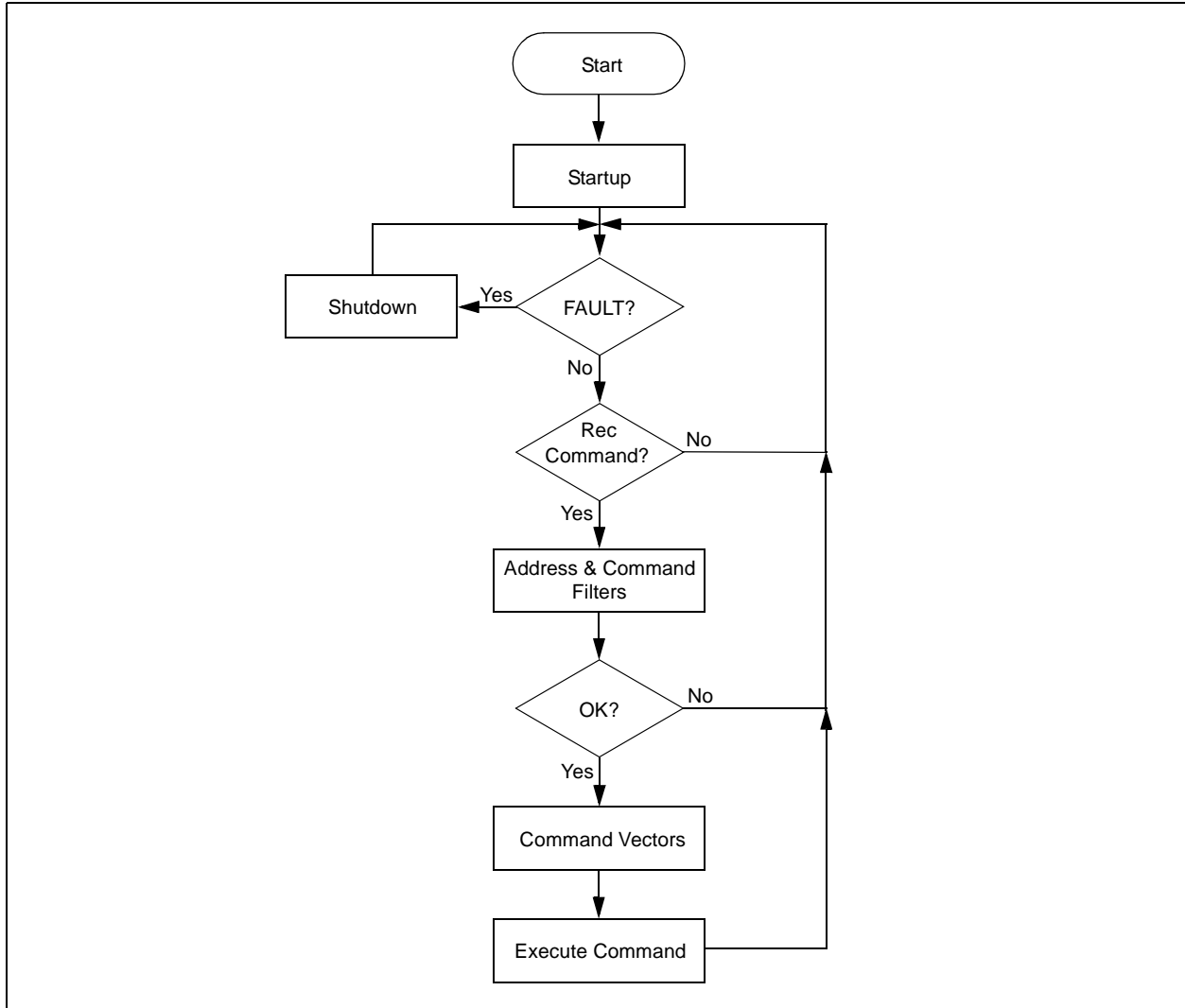

Isolation and the Signals for DALI

The DALI is optically isolated from the microcontroller. Figure 7 shows the connections between the DALI and microcontroller.

The two wires from the DALI are converted into four signals. Two of the four are the transmit signal (RB2) and receive signal (RX_DALI). The other two signals are the communications-enable (RB0) signal and the receive-drive (RB1) signal. The transmit signal and the receive signal directly correlate to the levels seen on the DALI. For receiving higher voltage logic on the DALI, the logic is translated to 5V logic at the microcontroller, and for transmission, the 5V logic is translated to the higher voltage logic on the DALI.

The ballast achieves very low power by controlling the communications circuit with the communication-enable signal and the receive-drive signal. During normal operation, the PIC16F628 enables the communication circuitry with the communication-enable signal. With this signal, there is enough current, less than 100 μA , to indicate when data is being sent to the ballast, but not enough current to accurately transfer the data. Upon detection (done by an S/H built into the PIC16F628), the receive-drive is asserted to raise the current above 500 μA to achieve good signal transfer across the isolation. The receive-drive signal is only enabled long enough to transfer all the data; then it is disabled (see waveforms in Figure 8). This method greatly reduces the power and current usage. The comparator built into the PIC16F628 is used to set the threshold for detection of the incoming data. The signal RA2 is used as a threshold for the comparator.

FIGURE 7: DALI AND MICROCONTROLLER CONNECTIONS

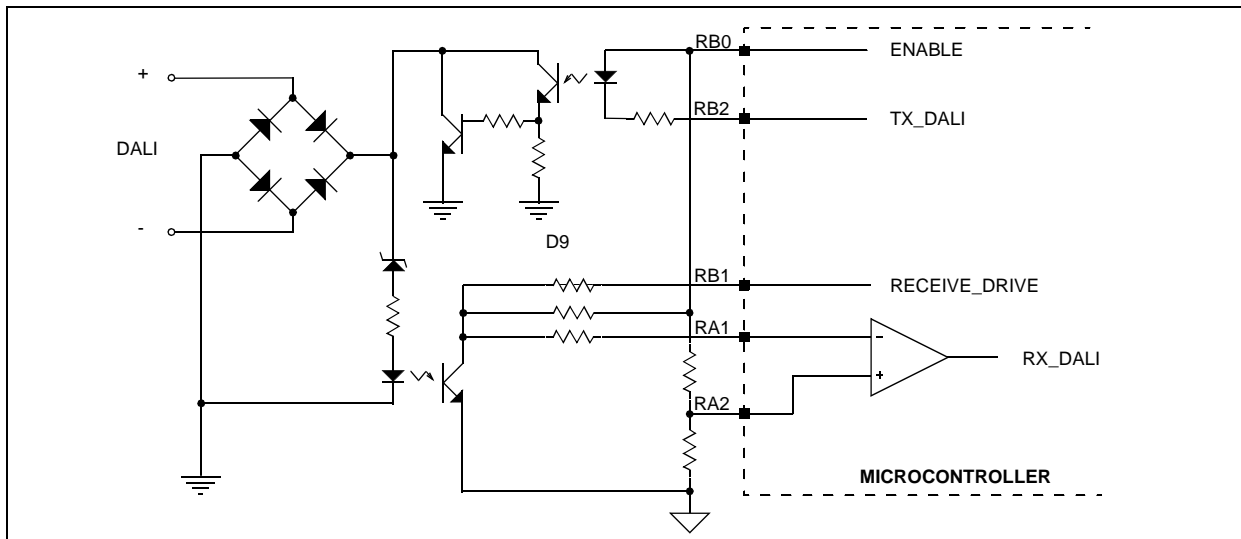
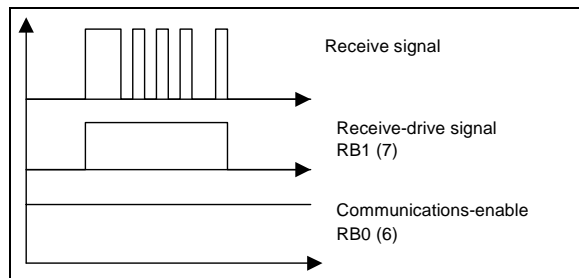

FIGURE 8: DALI / MICROCONTROLLER SIGNALS



Shutdown and Low Power

With shutdown, there are some unique power conditions. With the shutdown line low and the lamp ignited, the PIC16F628 derives its power from the charge pump of the IR2159. The charge pump provides enough current for the microcontroller to run at its internal frequency of 4 MHz during normal operation. When the shutdown line is asserted, the IR2159 is disabled and the charge pump is no longer functioning. Current is drawn directly from the high voltage DC line through a high value resistor. The microcontroller is put to sleep during this time to minimize current draw and power dissipation. To receive data, which requires significant current, the PIC16F628 wakes up and starts the charge pump of the IR2159 long enough to process the command, typically less than 25 ms, but not long enough to ignite the lamp (see waveforms in Figure 9). Doing this unique management minimizes power dissipation during shutdown.

Memory Usage of the PIC16F628

Much of the resources on the PIC16F628 are used to implement the DALI specification to its entirety. Table 1 shows the memory usage.

TABLE 1: MEMORY USAGE

Memory Type	Size	Used	%
Program	2181	1918	87.94
Data	224	71	31.70
EE Data	128	35	27.34

FIGURE 9: COMMUNICATIONS SIGNAL WITH THE LAMP OFF

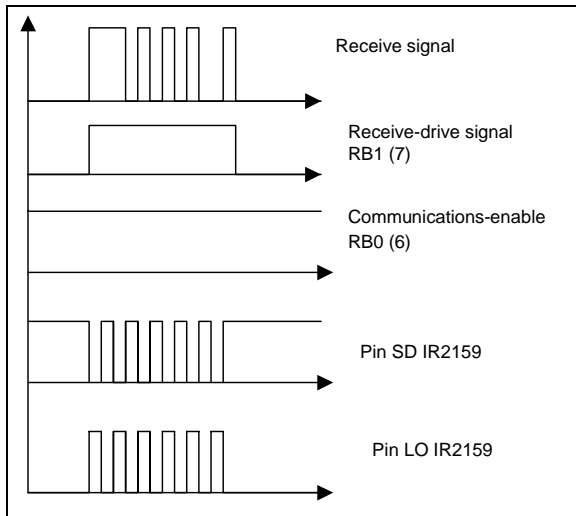

CONCLUSIONS

International Rectifier and Microchip jointly developed a solution for the digital dimming ballast. Its operation is based on the DALI standards, requiring very few parts, and operates at very low power. This is a good example of merging digital technology with high voltage analog technology.

CONTACT INFORMATION

For inquiries about reference design materials, including hardware and soft material on CD, contact International Rectifier.

<http://www.irf.com/product-info/lighting/>

To order a complete kit refer to:

<http://www.irf.com/forms/eltdk.html>

REFERENCES

1. T. Ribarich, J. Ribarich, "A New Design Procedure for High-Frequency Ballast Design," in IEEE-IAS Conf. Rec., 1997, pp. 2334-2339
2. T. Ribarich, J. Ribarich, "A New Control Method for Dimmable High Frequency Electronic Ballast," in IEEE-IAS Conf. Rec., 1998
3. T. Ribarich, J. Ribarich, "A New High-Frequency Fluorescent Lamp Model," in IEEE-IAS Conf. Rec., 1998
4. International Rectifier, "IR2159/IR21591 Dimmable Ballast Controller IC," Data Sheet, 2001

APPENDIX A: IRPLDIM2 SCHEMATIC

FIGURE A-1: IRPLDIM2 SCHEMATIC

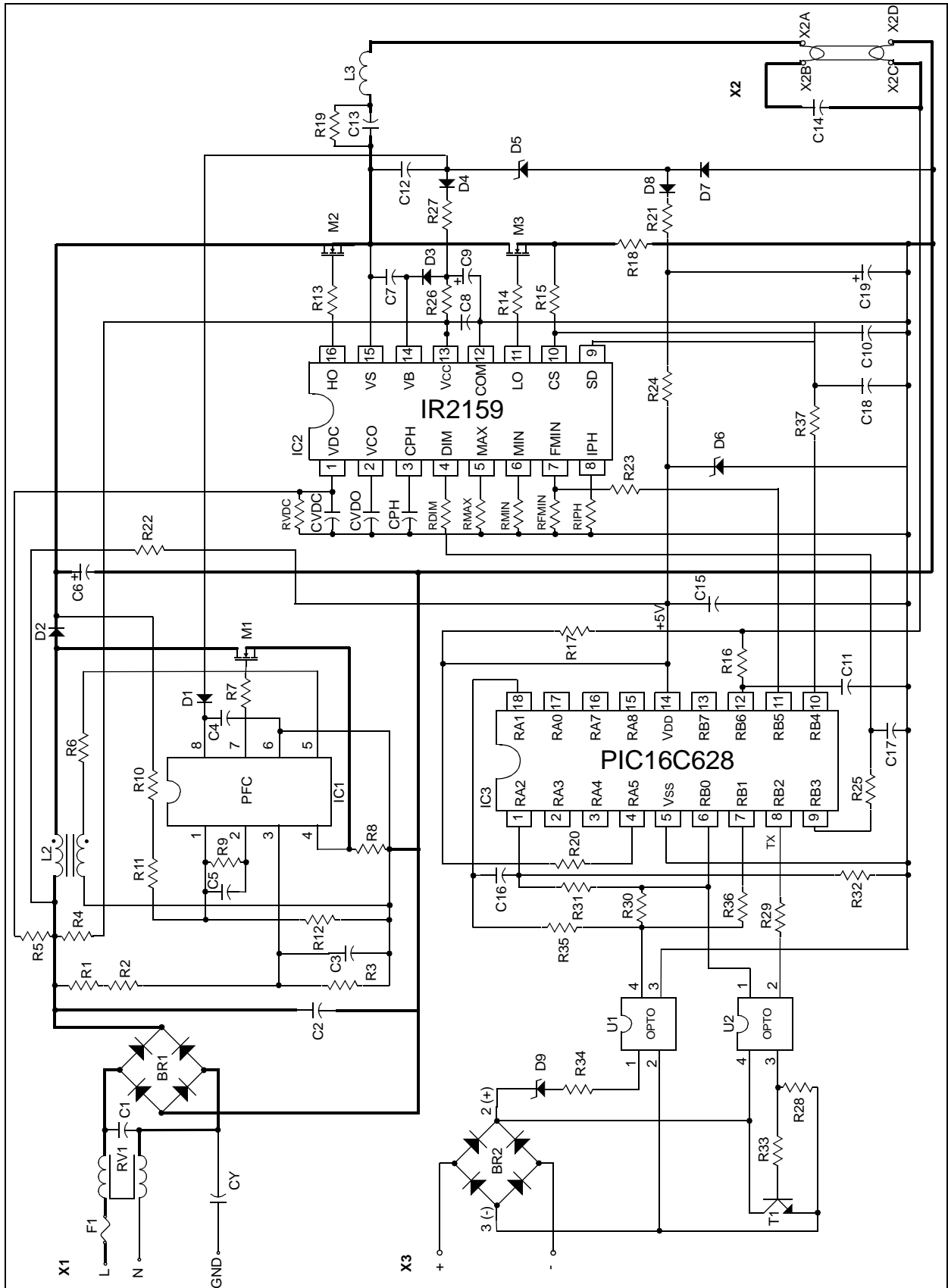

APPENDIX B: IRPLDIM2 BILL OF MATERIALS (BOM)

TABLE B-1: IRPLDIM2E BOM (LAMP TYPE: T8/36W; LINE INPUT VOLTAGE: 185 TO 265 VAC)

Item	Qty	Reference	Description	Manufacturer	PN
1	1	BR1	Bridge Rectifier, 1A, 1000V	IR	DF10S
2	4	C4, C5, CPH, CVdc	Capacitor, 0.47 μ F, SMT 1206	Panasonic	ECJ-3YB1E474K
3	1	C3	Capacitor, 0.01 μ F, SMT 1206	Panasonic	ECU-V1H103KBM
4	1	C1	Capacitor, 0.33 μ F, 275 VAC	Roederstein	F1772433-2200
5	2	C2, C13	Capacitor, 0.1 μ F, 400 VDC	Wima	MKP10
6	4	C7, C8, C11, C18	Capacitor, 0.1 μ F, SMT1206	Panasonic	ECJ-3VB1E104K
7	1	C15	Capacitor, 0.22 μ F, ceramic SMT 1206	Panasonic	
8	1	C6	Capacitor, 10 μ F, 450 Vdc, 105C	Panasonic	EEU-EB2V100
9	1	C9	Capacitor, 4.7 μ F, 25 VDC, 105C	Panasonic	EEU-FC1H4R7
10	1	C19	Capacitor, 2.2 μ F, 25 VDC, 105C	Panasonic	
11	1	C10	Capacitor, 220 pF, SMT 1206	Panasonic	ECU-V1H471KBM
12	1	C16	Capacitor, 1 nF, SMT 1206	Panasonic	
13	1	C12	Capacitor, 1 nF, 1KV, SMT 1812	Johanson	102S43W102KV4
14	1	C14	Capacitor, 10 nF, 1600 VDC	Panasonic	ECW-H16102JV
15	1	CVco	Capacitor, 22 nF, SMT 1206		
16	1	C17	Capacitor, 1 μ F, SMT 1206		
17	1	CY	Y-Capacitor		
18	4	D4, D7	Diode, 1N4148, SMT DL35	Diodes	LL4148
19	2	D1, D8	Diode, 1N4148	Diodes	
20	2	D2, D3	Diode, 1A 600V SMB	Digi-Key	MURS160DICT-ND
21	1	D5	12V Zener SMT	Digi-Key	ZMM5242BCT-ND
22	1	D9	5.1V Zener SMT	Digi-Key	ZMM5231BCT-ND
23	1	D6	5.6V Zener SMT	Digi-Key	
24	1	L1	EMI Inductor, 1x10 mH, 0.7A	Panasonic	ELF-15N007A
25	1	L2	PFC Inductor, 2.0 mH, 2.0Apk	Coilcraft	Z9265-A
26	1	L3	Inductor, 2.0 mH, 2.0Apk	Coilcraft	Z9264-A
27	3	M1, M2, M3	Transistor MOSFET	IR	IRF820
28	1	R15	Resistor, 1K Ohm, SMT 1206	Panasonic	ERJ-8GEYJ1KV
29	1	R33	Resistor, 750 Ohm, SMT 1206	Panasonic	
30	1	RFMIN	Resistor, 39K Ohm, SMT 1206	Panasonic	

TABLE B-1: IRPLDIM2E BOM (LAMP TYPE: T8/36W; LINE INPUT VOLTAGE: 185 TO 265 VAC (CON'T))

Item	Qty	Reference	Description	Manufacturer	PN
31	6	RDIM R12, R20, R34, R35, R36	Resistor, 10K Ohm, SMT 1206	Panasonic	ERJ-8GEYJ10KV
32	1	RIPH	Resistor, 18K Ohm, SMT 1206	Panasonic	
33	1	RVdc	Resistor, 27K Ohm, SMT 1206	Panasonic	ERJ-8GEYJ27KV
34	1	RMIN	Resistor, 28K Ohm, SMT 1206	Panasonic	
35	1	RMAX	Resistor, 33K Ohm, SMT 1206	Panasonic	
36	2	R1, R2	Resistor, 680K Ohm, SMT 1206	Panasonic	ERJ-8GEYJ680KV
37	1	R3	Resistor, 7.5K Ohm, SMT 1206	Panasonic	ERJ-8GEYJ7.5KV
38	1	R6	Resistor, 22K Ohm, SMT 1206	Panasonic	ERJ-8GEY22KV
39	5	R7, R13, R14, R21, R24	Resistor, 22 Ohm, SMT 1206	Panasonic	ERJ-8GEY22V
40	3	R9, R16, R30	Resistor, 100K Ohm, SMT 1206	Panasonic	ERJ-8GEY100KV
41	2	R10, R11	Resistor, 820K Ohm, SMT 1206	Panasonic	ERJ-8GEY820KV
42	1	R17	Resistor, 1M Ohm, SMT 1206	Panasonic	ERJ-8GEY1MV
43	1	R8	Resistor, 1 Ohm, ¼ Watt	Yageo	1.0QBK
44	1	R18	Resistor, 0.6 Ohm, ¼ Watt	Yageo	
45	1	R19	Resistor, 100K Ohm, ¼ Watt	Yageo	
46	1	R4	Resistor, 470K Ohm	Yageo	470KQBK
47	1	R5	Resistor, 1M Ohm	Yageo	
48	2	R26, R27	Resistor, 10 Ohm, SMT1206	Panasonic	
49	1	R22	Resistor, 270K Ohm, 0.5W	Yageo	
50	1	R23	Resistor, 470K Ohm, SMT1206	Panasonic	
51	1	R31	Resistor, 360K Ohm, SMT1206	Panasonic	
52	1	R28	Resistor, 4.7K Ohm, SMT 1206	Panasonic	
53	1	R29	Resistor, 2.2K Ohm, SMT 1206	Panasonic	
54	1	R32	Resistor, 75K, SMT 1206	Panasonic	
55	2	R25, R37	Resistor, 47K Ohm, SMT1206	Panasonic	
56	1	F1	Resistor, 0.5 Ohm, ½ Watt	Dale	CW-1/2
57	1	IC1	PFC IC for PWR FACTOR	ST	L6561D
58	1	IC2	IC, Dimming Ballast Controller	IR	IR2159
59	2	U1, U2	Mini-flat package Photo coupler	SHARP	PC357NT
60	1	U3	Microcontroller PDIP	Microchip	PIC16F628P
61	1	T1	SOT23 MP Transistor NPN	Digi-Key	FMMT491ACT-ND

AN809

TABLE B-1: IRPLDIM2E BOM (LAMP TYPE: T8/36W; LINE INPUT VOLTAGE: 185 TO 265 VAC (CON'T))

Item	Qty	Reference	Description	Manufacturer	PN
62	1	BR2	0.5A 200V Mini SM Bridge Rect.	General Semi-conductors	MB2S
63	1	X1	Connector, 2 terminal	Wago	
64	1	X2	Connector, 4 terminal	Wago	
65	1	X3	Phone Connector RJ11		
66	7	J1, J2, J3, J4, J5, J6, J7	Jumper		
67	8	R01, R02, R03, R04, R05, R06, R07, R08	Resistor, 0 Ohm, SMT 1206		

TABLE B-2: IRPLDIM2U BOM (LAMP TYPE: T8/32W; LINE INPUT VOLTAGE: 90 TO 140 VAC)

Item	Qty	Reference	Description	Manufacturer	PN
1	1	BR1	Bridge Rectifier, 1A, 1000V	IR	DF10S
2	3	C4, C5	Capacitor, 0.47 μ F, SMT 1206	Panasonic	ECJ-3YB1E474K
3	1	C3	Capacitor, 0.01 μ F, SMT 1206	Panasonic	ECU-V1H103KBM
4	1	C1	Capacitor, 0.33 μ F, 275 VAC	Roederstein	F1772433-2200
5	2	CPH, CVDC	Capacitor, 0.33 μ F, SMT 1206		
6	2	C2, C13	Capacitor, 0.1 μ F, 400 VDC	Wima	MKP10
7	4	C7, C8, C11, C18	Capacitor, 0.1 μ F, SMT 1206	Panasonic	ECJ-3VB1E104K
8	1	C15	Capacitor, 0.22 μ F, ceramic SMT 1206	Panasonic	
9	1	C6	Capacitor, 10 μ F, 350 VDC, 105C	Panasonic	
10	1	C9	Capacitor, 4.7 μ F, 25 VDC, 105C	Panasonic	EEU-FC1H4R7
11	1	C19	Capacitor, 2.2 μ F, 25 VDC, 105C	Panasonic	
12	1	C10	Capacitor, 220 pF, SMT 1206	Panasonic	ECU-V1H471KBM
13	1	C16	Capacitor, 1 nF, SMT 1206	Panasonic	
14	1	C12	Capacitor, 1.5 nF, 1KV, SMT 1812	Johanson	
15	1	C14	Capacitor, 8.2 nF, 1600 VDC	Panasonic	
16	1	CVco	Capacitor, 22 nF, SMT 1206		
17	1	C17	Capacitor, 1 μ F, SMT 1206		
18	1	CY	Y-Capacitor		
19	4	D4, D7	Diode, 1N4148, SMT DL35	Diodes	LL4148
20	2	D1, D8	Diode, 1N4148	Diodes	
21	2	D2, D3	Diode, 1A 600V SMB	Digi-Key	MURS160DICT-ND

TABLE B-2: IRPLDIM2U BOM (LAMP TYPE: T8/32W; LINE INPUT VOLTAGE: 90 TO 140 VAC (CON'T))

Item	Qty	Reference	Description	Manufacturer	PN
22	1	D5	12 V Zener SMT	Digi-Key	ZMM5242BCT-ND
23	1	D9	5.1 V Zener SMT	Digi-Key	ZMM5231BCT-ND
24	1	D6	5.6V Zener SMT	Digi-Key	
25	1	L1	EMI Inductor, 1x10 mH, 0.7A	Panasonic	ELF-15N007A
26	1	L2	PFC Inductor, 2.0 mH, 2.0Apk	Coilcraft	Z9265-A
27	1	L3	Inductor, 2.0 mH, 2.0Apk	Coilcraft	Z9264-A
28	2	M1	Transistor Mosfet	IR	IRF730
29	2	M2, M3	Transistor Mosfet	IR	IRF720
30	1	R15	Resistor, 1K Ohm, SMT 1206	Panasonic	ERJ-8GEYJ1KV
31	1	R33	Resistor, 750 Ohm, SMT 1206	Panasonic	
32	1	RFMIN	Resistor, 39K Ohm, SMT 1206	Panasonic	
33	6	RDIM, R20, R34, R35, R36	Resistor, 10K Ohm, SMT 1206	Panasonic	ERJ-8GEYJ10KV
34	1	RIPH	Resistor, 18K Ohm, SMT 1206	Panasonic	
35	1	R12	Resistor, 13K Ohm, SMT 1206	Panasonic	
36	1	RVDC	Resistor, 47K Ohm, SMT 1206	Panasonic	
37	1	RMIN	Resistor, 25.5K Ohm, SMT 1206	Panasonic	
38	1	RMAX	Resistor, 28K Ohm, SMT 1206	Panasonic	
39	2	R1, R2	Resistor, 680K Ohm, SMT 1206	Panasonic	ERJ-8GEYJ680KV
40	1	R3	Resistor, 7.5K Ohm, SMT 1206	Panasonic	ERJ-8GEYJ7.5KV
41	1	R6	Resistor, 22K Ohm, SMT1206	Panasonic	ERJ-8GEY22KV
42	5	R7, R13, R14, R21, R24	Resistor, 22 Ohm, SMT 1206	Panasonic	ERJ-8GEY22V
43	3	R9, R16, R30	Resistor, 100K Ohm, SMT 1206	Panasonic	ERJ-8GEY100KV
44	2	R10, R11	Resistor, 820K Ohm, SMT 1206	Panasonic	ERJ-8GEY820KV
45	1	R17	Resistor, 1M Ohm, SMT1206	Panasonic	ERJ-8GEY1MV
46	1	R8	Resistor, 1 Ohm, ¼ Watt	Yageo	1.0QBK
47	1	R18	Resistor, 0.75 Ohm, ¼ Watt	Yageo	
48	1	R19	Resistor, 100K Ohm, ¼ Watt	Yageo	
49	1	R4	Resistor, 330K Ohm	Yageo	
50	1	R5	Resistor, 1M Ohm	Yageo	
51	2	R26, R27	Resistor, 10 Ohm, SMT 1206	Panasonic	ERJ-*GEY10V
52	1	R22	Resistor, 135K Ohm, 0.5W	Yageo	

AN809

TABLE B-2: IRPLDIM2U BOM (LAMP TYPE: T8/32W; LINE INPUT VOLTAGE: 90 TO 140 VAC (CON'T))

Item	Qty	Reference	Description	Manufacturer	PN
53	1	R23	Resistor, 470K Ohm, SMT1206	Panasonic	
54	1	R31	Resistor, 360K Ohm, SMT1206	Panasonic	
55	1	R28	Resistor, 4.7K Ohm, SMT 1206	Panasonic	
56	1	R29	Resistor, 2.2K Ohm, SMT 1206	Panasonic	
57	1	R32	Resistor, 75K, SMT 1206	Panasonic	
58	2	R25, R37	Resistor, 47K Ohm, SMT1206	Panasonic	
59	1	F1	Resistor, 0.5 Ohm, ½ Watt	Dale	CW-1/2
60	1	IC1	PFC IC for PWR FACTOR	ST	L6561D
61	1	IC2	IC, Dimming Ballast Controller	IR	IR2159
62	2	U1, U2	Mini-flat package Photo coupler	SHARP	PC357NT
63	1	U3	Microcontroller PDIP	Microchip	PIC16F628P
64	1	T1	SOT23 MP Transistor NPN	Digi-Key	FMMT491ACT-ND
65	1	BR2	0.5A 200V Mini SM Bridge Rect.	General Semi-conductors	MB2S
66	1	X1	Connector, 2 terminal		
67	1	X2	Connector, 4 terminal	Wago	
68	1	X3	Phone Connector RJ11		
69	7	J1, J2, J3, J4, J5, J6, J7	Jumper		
70	8	R01, R02, R03, R04, R05, R06, R07, R08	Resistor, 0 Ohm, SMT 1206		

Note the following details of the code protection feature on PICmicro® MCUs.

- The PICmicro family meets the specifications contained in the Microchip Data Sheet.
- Microchip believes that its family of PICmicro microcontrollers is one of the most secure products of its kind on the market today, when used in the intended manner and under normal conditions.
- There are dishonest and possibly illegal methods used to breach the code protection feature. All of these methods, to our knowledge, require using the PICmicro microcontroller in a manner outside the operating specifications contained in the data sheet. The person doing so may be engaged in theft of intellectual property.
- Microchip is willing to work with the customer who is concerned about the integrity of their code.
- Neither Microchip nor any other semiconductor manufacturer can guarantee the security of their code. Code protection does not mean that we are guaranteeing the product as “unbreakable”.
- Code protection is constantly evolving. We at Microchip are committed to continuously improving the code protection features of our product.

If you have any further questions about this matter, please contact the local sales office nearest to you.

Information contained in this publication regarding device applications and the like is intended through suggestion only and may be superseded by updates. It is your responsibility to ensure that your application meets with your specifications. No representation or warranty is given and no liability is assumed by Microchip Technology Incorporated with respect to the accuracy or use of such information, or infringement of patents or other intellectual property rights arising from such use or otherwise. Use of Microchip's products as critical components in life support systems is not authorized except with express written approval by Microchip. No licenses are conveyed, implicitly or otherwise, under any intellectual property rights.

Trademarks

The Microchip name and logo, the Microchip logo, FilterLab, KEELOQ, microID, MPLAB, PIC, PICmicro, PICMASTER, PICSTART, PRO MATE, SEEVAL and The Embedded Control Solutions Company are registered trademarks of Microchip Technology Incorporated in the U.S.A. and other countries.

dsPIC, ECONOMONITOR, FanSense, FlexROM, fuzzyLAB, In-Circuit Serial Programming, ICSP, ICEPIC, microPort, Migratable Memory, MPASM, MPLIB, MPLINK, MPSIM, MXDEV, PICC, PICDEM, PICDEM.net, rfPIC, Select Mode and Total Endurance are trademarks of Microchip Technology Incorporated in the U.S.A.

Serialized Quick Turn Programming (SQTP) is a service mark of Microchip Technology Incorporated in the U.S.A.

All other trademarks mentioned herein are property of their respective companies.

© 2002, Microchip Technology Incorporated, Printed in the U.S.A., All Rights Reserved.

 Printed on recycled paper.

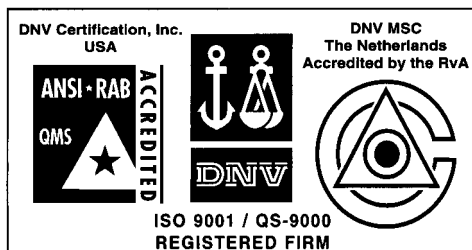

Microchip received QS-9000 quality system certification for its worldwide headquarters, design and wafer fabrication facilities in Chandler and Tempe, Arizona in July 1999. The Company's quality system processes and procedures are QS-9000 compliant for its PICmicro® 8-bit MCUs, KEELOQ® code hopping devices, Serial EEPROMs and microperipheral products. In addition, Microchip's quality system for the design and manufacture of development systems is ISO 9001 certified.



WORLDWIDE SALES AND SERVICE

AMERICAS

Corporate Office

2355 West Chandler Blvd.
Chandler, AZ 85224-6199
Tel: 480-792-7200 Fax: 480-792-7277
Technical Support: 480-792-7627
Web Address: <http://www.microchip.com>

Rocky Mountain

2355 West Chandler Blvd.
Chandler, AZ 85224-6199
Tel: 480-692-7966 Fax: 480-792-7456

Atlanta

500 Sugar Mill Road, Suite 200B
Atlanta, GA 30350
Tel: 770-640-0034 Fax: 770-640-0307

Boston

2 Lan Drive, Suite 120
Westford, MA 01886
Tel: 978-692-3848 Fax: 978-692-3821

Chicago

333 Pierce Road, Suite 180
Itasca, IL 60143
Tel: 630-285-0071 Fax: 630-285-0075

Dallas

4570 Westgrove Drive, Suite 160
Addison, TX 75001
Tel: 972-818-7423 Fax: 972-818-2924

Detroit

Tri-Atria Office Building
32255 Northwestern Highway, Suite 190
Farmington Hills, MI 48334
Tel: 248-538-2250 Fax: 248-538-2260

Kokomo

2767 S. Albright Road
Kokomo, Indiana 46902
Tel: 765-864-8360 Fax: 765-864-8387

Los Angeles

18201 Von Karman, Suite 1090
Irvine, CA 92612
Tel: 949-263-1888 Fax: 949-263-1338

New York

150 Motor Parkway, Suite 202
Hauppauge, NY 11788
Tel: 631-273-5305 Fax: 631-273-5335

San Jose

Microchip Technology Inc.
2107 North First Street, Suite 590
San Jose, CA 95131
Tel: 408-436-7950 Fax: 408-436-7955

Toronto

6285 Northam Drive, Suite 108
Mississauga, Ontario L4V 1X5, Canada
Tel: 905-673-0699 Fax: 905-673-6509

ASIA/PACIFIC

Australia

Microchip Technology Australia Pty Ltd
Suite 22, 41 Rawson Street
Epping 2121, NSW
Australia
Tel: 61-2-9868-6733 Fax: 61-2-9868-6755

China - Beijing

Microchip Technology Consulting (Shanghai)
Co., Ltd., Beijing Liaison Office
Unit 915
Bei Hai Wan Tai Bldg.
No. 6 Chaoyangmen Beidajie
Beijing, 100027, No. China
Tel: 86-10-85282100 Fax: 86-10-85282104

China - Chengdu

Microchip Technology Consulting (Shanghai)
Co., Ltd., Chengdu Liaison Office
Rm. 2401, 24th Floor,
Ming Xing Financial Tower
No. 88 TIDU Street
Chengdu 610016, China
Tel: 86-28-6766200 Fax: 86-28-6766599

China - Fuzhou

Microchip Technology Consulting (Shanghai)
Co., Ltd., Fuzhou Liaison Office
Unit 28F, World Trade Plaza
No. 71 Wusi Road
Fuzhou 350001, China
Tel: 86-591-7503506 Fax: 86-591-7503521

China - Shanghai

Microchip Technology Consulting (Shanghai)
Co., Ltd.
Room 701, Bldg. B
Far East International Plaza
No. 317 Xian Xia Road
Shanghai, 200051
Tel: 86-21-6275-5700 Fax: 86-21-6275-5060

China - Shenzhen

Microchip Technology Consulting (Shanghai)
Co., Ltd., Shenzhen Liaison Office
Rm. 1315, 13/F, Shenzhen Kerry Centre,
Renminnan Lu
Shenzhen 518001, China
Tel: 86-755-2350361 Fax: 86-755-2366086

Hong Kong

Microchip Technology Hongkong Ltd.
Unit 901-6, Tower 2, Metroplaza
223 Hing Fong Road
Kwai Fong, N.T., Hong Kong
Tel: 852-2401-1200 Fax: 852-2401-3431

India

Microchip Technology Inc.
India Liaison Office
Divyasree Chambers
1 Floor, Wing A (A3/A4)
No. 11, O'Shaugnessey Road
Bangalore, 560 025, India
Tel: 91-80-2290061 Fax: 91-80-2290062

Japan

Microchip Technology Japan K.K.
Benex S-1 6F
3-18-20, Shinyokohama
Kohoku-Ku, Yokohama-shi
Kanagawa, 222-0033, Japan
Tel: 81-45-471-6166 Fax: 81-45-471-6122

Korea

Microchip Technology Korea
168-1, Youngbo Bldg. 3 Floor
Samsung-Dong, Kangnam-Ku
Seoul, Korea 135-882
Tel: 82-2-554-7200 Fax: 82-2-558-5934

Singapore

Microchip Technology Singapore Pte Ltd.
200 Middle Road
#07-02 Prime Centre
Singapore, 188980
Tel: 65-6334-8870 Fax: 65-6334-8850

Taiwan

Microchip Technology Taiwan
11F-3, No. 207
Tung Hua North Road
Taipei, 105, Taiwan
Tel: 886-2-2717-7175 Fax: 886-2-2545-0139

EUROPE

Denmark

Microchip Technology Nordic ApS
Regus Business Centre
Lautrup høj 1-3
Ballerup DK-2750 Denmark
Tel: 45 4420 9895 Fax: 45 4420 9910

France

Microchip Technology SARL
Parc d'Activite du Moulin de Massy
43 Rue du Saule Trapu
Batiment A - 1er Etage
91300 Massy, France
Tel: 33-1-69-53-63-20 Fax: 33-1-69-30-90-79

Germany

Microchip Technology GmbH
Gustav-Heinemann Ring 125
D-81739 Munich, Germany
Tel: 49-89-627-144 0 Fax: 49-89-627-144-44

Italy

Microchip Technology SRL
Centro Direzionale Colleoni
Palazzo Taurus 1 V. Le Colleoni 1
20041 Agrate Brianza
Milan, Italy
Tel: 39-039-65791-1 Fax: 39-039-6899883

United Kingdom

Arizona Microchip Technology Ltd.
505 Eskdale Road
Winnersh Triangle
Wokingham
Berkshire, England RG41 5TU
Tel: 44 118 921 5869 Fax: 44-118 921-5820

03/01/02