

UL 1977

ISBN 1-55989-948-4

Component Connectors for  
Use in Data, Signal, Control  
and Power Applications



Underwriters Laboratories Inc. (UL)  
333 Pfingsten Road  
Northbrook, IL 60062-2096

UL Standard for Safety for Component Connectors for Use in Data, Signal, Control and Power Applications, UL 1977

First Edition, Dated December 22, 1995

Revisions: This Standard contains revisions through and including October 18, 2002.

Text that has been changed in any manner is marked with a vertical line in the margin. Changes in requirements are marked with a vertical line in the margin and are followed by an effective date note indicating the date of publication or the date on which the changed requirement becomes effective.

UL Standards for Safety are developed and maintained in the Standard Generalized Markup Language (SGML). SGML -- an international standard (ISO 8879-1986) -- is a descriptive markup language that describes a document's structure and purpose, rather than its physical appearance on a page. Due to formatting differences resulting from the use of UL's new electronic publishing system, please note that additional pages (on which no requirements have been changed) may be included in revision pages due to relocation of existing text and reformatting of the Standard.

The revised requirements are substantially in accordance with UL's Bulletin on this subject dated June 24, 2002. The bulletin is now obsolete and may be discarded.

The revisions dated October 18, 2002 include a reprinted title page (page1) for this Standard.

As indicated on the title page (page 1), this UL Standard for Safety is an American National Standard. Attention is directed to the note on the title page of this Standard outlining the procedures to be followed to retain the approved text of this ANSI/UL Standard.

The master for this Standard at UL's Northbrook Office is the official document insofar as it relates to a UL service and the compliance of a product with respect to the requirements for that product and service, or if there are questions regarding the accuracy of this Standard.

UL's Standards for Safety are copyrighted by UL. Neither a printed copy of a Standard, nor the distribution diskette for a Standard-on-Diskette and the file for the Standard on the distribution diskette should be altered in any way. All of UL's Standards and all copyrights, ownerships, and rights regarding those Standards shall remain the sole and exclusive property of UL.

All rights reserved. No part of this publication may be reproduced, stored in a retrieval system, or transmitted in any form by any means, electronic, mechanical photocopying, recording, or otherwise without prior permission of UL.

Revisions of UL Standards for Safety are issued from time to time. A UL Standard for Safety is current only if it incorporates the most recently adopted revisions.

UL provides this Standard "as is" without warranty of any kind, either expressed or implied, including but not limited to, the implied warranties of merchantability or fitness for any purpose.

In no event will UL be liable for any special, incidental, consequential, indirect or similar damages, including loss of profits, lost savings, loss of data, or any other damages arising out of the use of or the inability to use this Standard, even if UL or an authorized UL representative has been advised of the possibility of such damage. In no event shall UL's liability for any damage ever exceed the price paid for this Standard, regardless of the form of the claim.

UL will attempt to answer support requests concerning electronic versions of its Standards. However, this support service is offered on a reasonable efforts basis only, and UL may not be able to resolve every support request. UL supports the electronic versions of its Standards only if they are used under the conditions and operating systems for which it is intended. UL's support policies may change from time-to-time without notification.

UL reserves the right to change the format, presentation, file types and formats, delivery methods and formats, and the like of both its printed and electronic Standards without prior notice.

Purchasers of the electronic versions of UL's Standards for Safety agree to defend, indemnify, and hold UL harmless from and against any loss, expense, liability, damage, claim, or judgement (including reasonable attorney's fees) resulting from any error or deviation introduced while purchaser is storing an electronic Standard on the purchaser's computer system.

If a single-user version electronic Standard was purchased, one copy of this Standard may be stored on the hard disk of a single personal computer, or on a single LAN file-server or the permanent storage device of a multiple-user computer in such a manner that this Standard may only be accessed by one user at a time and for which there is no possibility of multiple concurrent access.

If a multiple-user version electronic Standard was purchased, one copy of the Standard may be stored on a single LAN file-server, or on the permanent storage device of a multiple-user computer, or on an Intranet server. The number of concurrent users shall not exceed the number of users authorized.

Electronic Standards are intended for on-line use, such as for viewing the requirements of a Standard, conducting a word search, and the like. Only one copy of the Standard may be printed from each single-user version of an electronic Standard. Only one copy of the Standard may be printed for each authorized user of a multiple-user version of an electronic Standard. Because of differences in the computer/software/printer setup used by UL and those of electronic Standards purchasers, the printed copy obtained by a purchaser may not look exactly like the on-line screen view or the printed Standard.

An employee of an organization purchasing a UL Standard can make a copy of the page or pages being viewed for their own fair and/or practical internal use.

The requirements in this Standard are now in effect, except for those paragraphs, sections, tables, figures, and/or other elements of the Standard having future effective dates as indicated in the note following the affected item. The prior text for requirements that have been revised and that have a future effective date are located after the Standard, and are preceded by a "SUPERSEDED REQUIREMENTS" notice.

New product submittals made prior to a specified future effective date will be judged under all of the requirements in this Standard including those requirements with a specified future effective date, unless the applicant specifically requests that the product be judged under the current requirements. However, if the applicant elects this option, it should be noted that compliance with all the requirements in this Standard will be required as a condition of continued and Follow-Up Services after the effective date, and understanding of this should be signified in writing.

This Standard consists of pages dated as shown in the following checklist:

Page	Date
1-6 .....	October 18, 2002
7 .....	December 12, 2000
8 .....	October 18, 2002
8A-8B .....	December 12, 2000
9 .....	December 22, 1995
10-13 .....	October 18, 2002
14 .....	November 4, 1997
15-16 .....	December 22, 1995
17 .....	October 18, 2002
18-20 .....	December 12, 2000
A1-A2 .....	December 22, 1995

No Text on This Page

**DECEMBER 22, 1995**  
(Title Page Reprinted: October 18, 2002)



1

**UL 1977**

**ANSI/UL 1977-1998**

**Standard for Component Connectors for Use in Data, Signal, Control and  
Power Applications**

**First Edition**

**December 22, 1995**

Approval as an American National Standard (ANSI) covers the numbered paragraphs on pages dated December 22, 1995, March 6, 1998, and January 8, 1999. These pages should not be discarded when revised or additional pages are issued if it is desired to retain the ANSI approved text.

An effective date included as a note immediately following certain requirements is one established by Underwriters Laboratories Inc.

Approved as ANSI/UL 1977-1998, July 7, 1998

Revisions of this Standard will be made by issuing revised or additional pages bearing their date of issue. A UL Standard is current only if it incorporates the most recently adopted revisions, all of which are itemized on the transmittal notice that accompanies the latest set of revised requirements.

**ISBN 1-55989-948-4**

**COPYRIGHT © 1995, 2002 UNDERWRITERS LABORATORIES INC.**

No Text on This Page



**CONTENTS**

<b>FOREWORD</b> .....	4
-----------------------	---

**INTRODUCTION**

1 Scope .....	5
2 Glossary .....	7
3 Components .....	7
4 Units of Measurement .....	8
5 References .....	8

**CONSTRUCTION**

6 General .....	8
7 Insulating Materials .....	8
8 Current-Carrying Parts .....	8A
9 Grounding and Dead-Metal Parts .....	9
10 Assembly .....	10
10.1 General .....	10
10.2 Accessibility of live parts .....	10
10.3 Connection between mating devices .....	10
11 Spacings .....	12

**PERFORMANCE**

12 General .....	13
13 Accelerated Aging Test .....	14
13.1 Rubber compounds .....	14
13.2 PVC compounds .....	14
14 Mold Stress Relief Test .....	14
15 Overload Test .....	15
16 Temperature Test .....	16
17 Dielectric Voltage-Withstand Test .....	17
18 Resistance To Arcing Test .....	17
19 Conductor Secureness Test .....	18
19A Flammability Test .....	18

**MARKINGS**

20 General .....	18
------------------	----

**APPENDIX A**

Standards for Components.....	A1
-------------------------------	----

## FOREWORD

A. This Standard contains basic requirements for products covered by Underwriters Laboratories Inc. (UL) under its Follow-Up Service for this category within the limitations given below and in the Scope section of this Standard. These requirements are based upon sound engineering principles, research, records of tests and field experience, and an appreciation of the problems of manufacture, installation, and use derived from consultation with and information obtained from manufacturers, users, inspection authorities, and others having specialized experience. They are subject to revision as further experience and investigation may show is necessary or desirable.

B. The observance of the requirements of this Standard by a manufacturer is one of the conditions of the continued coverage of the manufacturer's product.

C. A product which complies with the text of this Standard will not necessarily be judged to comply with the Standard if, when examined and tested, it is found to have other features which impair the level of safety contemplated by these requirements.

D. A product that contains features, characteristics, components, materials, or systems new or different from those covered by the requirements in this standard, and that involves a risk of fire or of electric shock or injury to persons shall be evaluated using appropriate additional component and end-product requirements to maintain the level of safety as originally anticipated by the intent of this standard. A product whose features, characteristics, components, materials, or systems conflict with specific requirements or provisions of this standard does not comply with this standard. Revision of requirements shall be proposed and adopted in conformance with the methods employed for development, revision, and implementation of this standard.

E. UL, in performing its functions in accordance with its objectives, does not assume or undertake to discharge any responsibility of the manufacturer or any other party. The opinions and findings of UL represent its professional judgment given with due consideration to the necessary limitations of practical operation and state of the art at the time the Standard is processed. UL shall not be responsible to anyone for the use of or reliance upon this Standard by anyone. UL shall not incur any obligation or liability for damages, including consequential damages, arising out of or in connection with the use, interpretation of, or reliance upon this Standard.

F. Many tests required by the Standards of UL are inherently hazardous and adequate safeguards for personnel and property shall be employed in conducting such tests.

## INTRODUCTION

### 1 Scope

1.1 These requirements cover single and multipole connectors, intended for factory assembly to copper or copper alloy conductors or printed wiring boards, for use in data, signal, control and power applications within and between electrical equipment.

1.2 These requirements apply to devices categorized as follows (See Figure 1.1 ):

- a) Type 0 rated less than 8.3 A and less than 30 V rms (42 V peak);
- b) Type 1A rated less than 8.3 A and from 30 V up to and including 600 V ac or dc, or both;
- c) Type 1B rated from 8.3 A up to and including 200 A, and less than 30 V rms (42 V peak);
- d) Type 2 rated from 8.3 A to less than 31 A and from 30 V up to and including 600 V ac or dc or both;
- e) Type 3 rated from 31 A up to and including 200 A and from 30 V up to and including 600 V ac or dc, or both.
- f) Type 4 rated from greater than 200 A up to and including 1000 A, and up to and including 600 V ac or dc.

Type designations used in this Standard only serve as a guide to determine appropriate requirements, and do not represent an assigned rating. A device not assigned a current rating is considered either to be Type 0 or Type 1A depending upon the assigned voltage rating.

1.2 revised October 18, 2002

1.3 This standard does not directly apply to the following but may supplement other applicable standards:

- a) Devices produced integrally with flexible cord or cable that are covered by the Standard for Cord Sets and Power-Supply Cords, UL 817;
- b) Devices intended for connection to the branch circuit, such as attachment plugs, cord connectors, receptacles, inlets, and outlets, that are covered by the Standard for Attachment Plugs and Receptacles, UL 498;
- c) Devices solely intended for direct connection to the branch circuit in accordance with the National Electrical Code, NFPA 70, and that are provided with contacts of the pin and sleeve type, covered by the requirements for plugs, receptacles, and cable connectors of the pin and sleeve type, UL 1682;
- d) Devices consisting of wiring terminals and supporting blocks intended for the connection of wiring that are covered by the Standard for Terminal Blocks, UL 1059;
- e) Devices intended for use with telecommunications networks, that are covered by the Standard for Telephone Equipment, UL 1459, or the Standard for Communications Circuit Accessories, UL 1863;

### Figure 1.1 Connector type designations

Figure 1.1 revised October 18, 2002

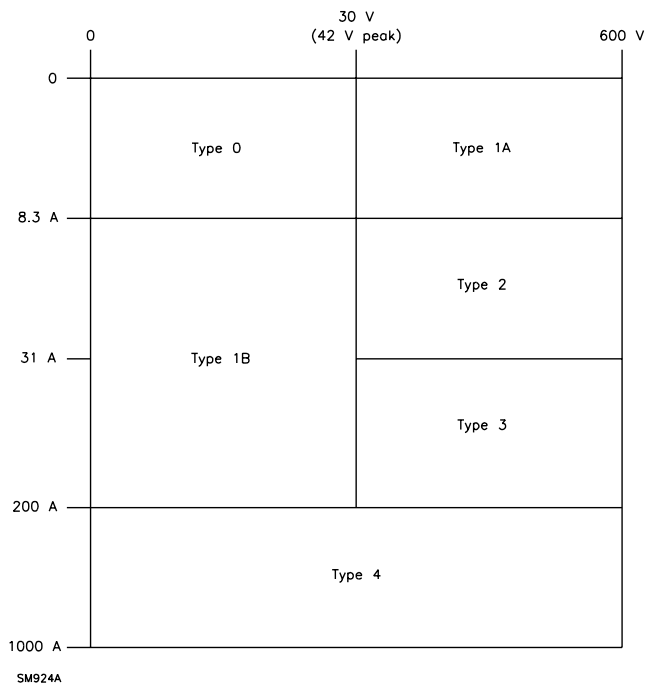

f) Devices such as wire connectors and soldering lugs that are covered by the Standards for Wire Connectors – For Use With Copper Conductors, UL 486A; Splicing Wire Connectors, UL 486C; or Equipment Wiring Terminals, UL 486E;

g) Devices such as quick-connect terminals that are covered by the Standard for Quick Connect Terminals, UL 310.

1.4 Deleted October 18, 2002

## 2 Glossary

2.1 For the purpose of this Standard, the following definitions apply.

2.2 CONTACT – A conductive element intended to mate with a corresponding element to provide an electrical path.

2.3 ENCLOSURE – The case or housing into which the insulator and contacts are assembled.

2.4 HYBRID DEVICE – A device employing dedicated contacts of two or more type designations.

2.5 INSULATOR – The portion of a device that provides for separation and support of contacts. May be combined with the enclosure.

2.6 TERMINAL – A conductive part provided on a contact for connecting a conductor.

## 3 Components

3.1 Except as indicated in 3.2, a component of a product covered by this standard shall comply with the requirements for that component. See Appendix A for a list of standards covering components used in the products covered by this standard.

3.1 revised December 12, 2000

3.2 A component is not required to comply with a specific requirement that:

a) Involves a feature or characteristic not required in the application of the component in the product covered by this standard, or

b) Is superseded by a requirement in this standard.

3.2 revised December 12, 2000

3.3 A component shall be used in accordance with its rating established for the intended conditions of use.

3.3 revised December 12, 2000

3.4 Specific components are incomplete in construction features or restricted in performance capabilities. Such components are intended for use only under limited conditions, such as certain temperatures not exceeding specified limits, and shall be used only under those specific conditions.

3.4 revised December 12, 2000

## 4 Units of Measurement

4.1 Values stated without parentheses are the requirement. Values in parentheses are explanatory or approximate information.

4.1 revised December 12, 2000

## 5 References

5.1 Any undated reference to a code or standard appearing in the requirements of this standard shall be interpreted as referring to the latest edition of that code or standard.

## CONSTRUCTION

### 6 General

6.1 Devices complying with these requirements are acceptable for use as components in an end product where the acceptability of the combination is to be determined.

6.2 The acceptability of a connector in any particular application depends on its ability to be used under the conditions that prevail in actual service. For a particular application, a connector may be affected by the requirements for the equipment in which it is used, and it may be necessary to additionally evaluate features or performance characteristics that are not specified in this standard.

### 7 Insulating Materials

7.1 A base or body in or on which live parts are mounted shall be of porcelain or another insulating material acceptable for the particular application.

7.2 A polymeric material used as an electrical insulator, an internal barrier necessary to maintain spacings, or an enclosure of live parts shall comply with the requirements shown in Table 7.1.

**Table 7.1**  
**Minimum ratings for polymeric materials**

Table 7.1 revised October 18, 2002

Type	Flame rating	Relative thermal index (RTI) Electrical/ mechanical w/o impact <sup>a,b</sup>
0	–	50/50
1A	HB	50/50
1B	HB	50/50
2	HB	50/50
3	HB	50/50
4	HB	50/50

<sup>a</sup> The RTI of the material shall not be lower than the temperature measured during the Temperature Test.

<sup>b</sup> For a thickness less than that for which a value has been established, the RTI of the minimum thickness with an established value shall be used.

## 8 Current-Carrying Parts

8.1 Device contacts shall be constructed of plated or unplated copper or copper alloy. Other materials may be accepted if they are found to provide adequate electrical and mechanical characteristics as a result of special investigation.

8.2 Iron or steel, whether plain or plated, shall not be used for parts that are depended upon to carry current.

*Exception: Parts that are depended upon to carry current in high temperature applications may be of suitably plated or stainless steel.*

No Text on This Page



8.3 A current-carrying part shall be secured in place so that turning relative to the surface on which it is mounted would not adversely affect the performance of the device.

8.4 A terminal plate threaded for a wire-binding screw shall:

- a) be at least 0.76 mm (0.03 in) thick,
- b) thread into metal, and
- c) have at least two complete threads.

In order to obtain two complete threads, the metal of the terminal plate at the tapped hole may be extruded.

8.5 The minimum size for a wire-binding screw shall be as indicated in Table 8.1.

**Table 8.1**  
**Minimum sizes of wire binding screws**

Rating maximum A	Minimum screw size American No. (metric)	Minimum head diameter, mm (in)
15	5 (M3)	6.3 (0.25)
20	6 (M3.5)	7.0 (0.28)
30	8 (M4)	8.3 (0.33)

## 9 Grounding and Dead-Metal Parts

9.1 Non-current carrying parts of ferrous metal (other than stainless steel), including mounting screws, shall be protected against corrosion by zinc plating, or an equivalent protective coating.

9.2 Dead metal parts of a device provided with a socket contact identified for use as an equipment-grounding conductor shall be conductively connected to the grounding-conductor path.

9.3 An identified grounding contact, or grounding-conductor path through a device shall be of plated or unplated copper or copper-based alloy.

*Exception No. 1: A metal housing, shell or armor of a device in the path of the identified grounding conductor need not be of copper or copper-based alloy, but shall employ a copper or copper-base alloy contact for connection to the housing of a mating device.*

*Exception No. 2: A device mounting means need not be copper or copper-based alloy.*

*Exception No. 3: Other materials may be acceptable if they are found to provide equivalent electrical and mechanical characteristics as a result of special investigation.*

## 10 Assembly

### 10.1 General

10.1.1 A device shall be capable of being readily installed as intended.

10.1.2 A polarized device incorporating two or more contacts shall be keyed or of such design that the polarization can not be defeated by improper assembly during installation.

10.1.3 Any two or more device parts that may be separated during installation shall not be capable of an assembly that will defeat the intended polarization of wiring.

### 10.2 Accessibility of live parts

10.2.1 A connector of Types 1A, 2, 3, or 4 intended for usage external to the end equipment shall have live parts protected against exposure to contact by persons when assembled, installed and mated as intended, as determined by the use of the probe shown in Figure 10.1.

10.2.1 revised October 18, 2002

10.2.2 Mating devices of Types 1A, 2, 3, or 4 intended for usage external to the end equipment shall not have exposed live contacts during engagement or withdrawal as determined by the use of the probe shown in Figure 10.1.

10.2.2 revised October 18, 2002

### 10.3 Connection between mating devices

10.3.1 A hybrid device shall be polarized or otherwise constructed so that contacts with different Type designations cannot make electrical contact when mating devices are connected together.

10.3.2 A device provided with an identified grounding contact shall be so constructed that the grounding pin of the corresponding mating device when wired as intended, cannot be inserted into any other opening so as to touch a live contact or other live part.

10.3.3 An identified grounding contact provided on a device shall be located and formed so that the path of electrical continuity to the grounding contact of a mating device is completed before continuity is established between any other contact and its respective contact in the mating device.

*Exception: A Type 0 or 1B device need not comply with this requirement.*

Figure 10.1  
Articulate probe with web stop

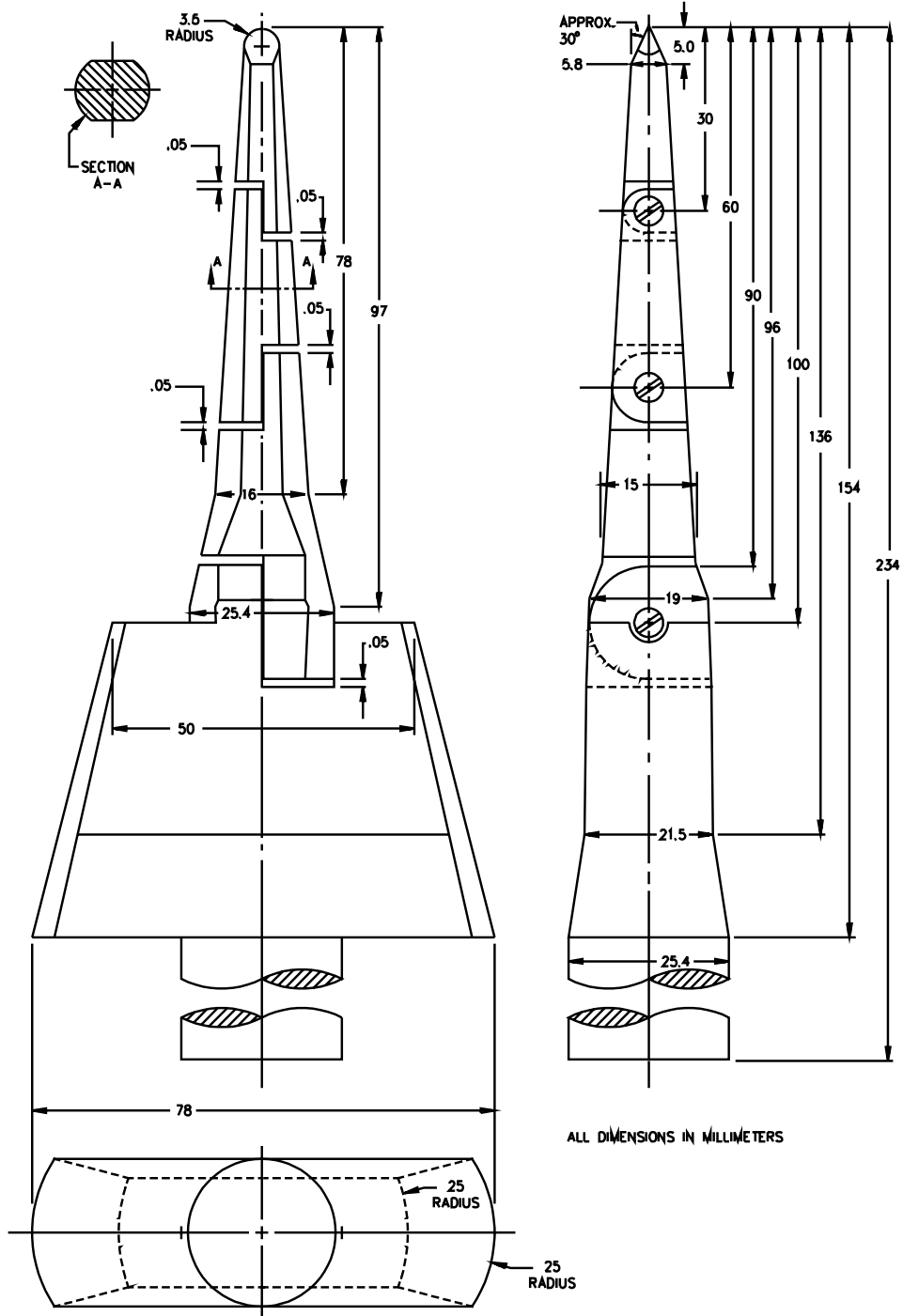

PA100A

## 11 Spacings

11.1 For devices as specified in Table 11.1 there shall be a spacing through air or over surface of 1.2 mm (3/64 inch) or more for a device rated at 250 volts or less, and 3.2 mm (1/8 inch) or more for a device rated at more than 250 volts, between an uninsulated live part and:

- a) an uninsulated live part of opposite polarity,
- b) an uninsulated grounded metal part, or
- c) a non-current carrying metal part that is exposed to contact by persons when the device is installed and used in the intended manner.

*Exception: Spacings less than those specified are permitted if the device complies with the requirements in the Dielectric Voltage-Withstand Test, Section 17.*

**Table 11.1**  
**Applicability of spacing requirements**

Table 11.1 revised October 18, 2002

Type	Uninsulated live part – uninsulated live part of opposite polarity	Uninsulated live part – uninsulated grounded metal part	Uninsulated live part – exposed dead metal part
0	No	No	No
1A	Yes	Yes	Yes
1B	Yes	Yes	No
2	Yes	Yes	Yes
3	Yes	Yes	Yes
4	Yes	Yes	Yes

11.2 In measuring a spacing, an isolated dead-metal part interposed between parts under consideration shall be considered to reduce the spacing by an amount equal to the dimension of the isolated dead-metal part in the direction of the measurement.

11.3 Spacings are to be evaluated in all conditions of use, both with and without mating devices of the intended configuration installed and any movable parts displaced to the position of minimum spacings.

## PERFORMANCE

### 12 General

12.1 The performance of devices covered by this Standard shall be investigated by subjecting representative devices in commercial form to the applicable tests described in Sections 13 – 19A. Those tests that are required to be performed on each connector Type designation are indicated in Table 12.1.

12.1 revised December 12, 2000

12.2 Unless stated otherwise, tests are to be conducted on six representative devices with acceptable results.

12.3 Devices employing contacts with different Type designations within a single housing shall be subjected to the tests indicated in Table 12.1 for all applicable Type designations.

**Table 12.1**  
**Connector test programs**

Table 12.1 revised October 18, 2002

Test	Section	Connector Type					
		Type 0	Type 1A	Type 1B	Type 2	Type 3	Type 4
Accelerated aging	13	O	O	O	O	O	O
Mold stress relief	14	X	X	X	X	X	X
Overload	15	–	O	O	O	O	N
Temperature	16	Y	Y	X	X	X	X
Dielectric voltage-withstand	17	–	O	O	O	O	O
Resistance to arcing	18	–	O	O	O	O	N
Conductor secureness	19	O	O	O	O	O	O
Flammability	19A	OA	OA	OA	OA	OA	OA
X – Required Y – Required if device has an assigned current rating. O – Optional for some devices. Refer to test description for details. OA – Optional for all devices. N – Not permitted.							

## 13 Accelerated Aging Test

### 13.1 Rubber compounds

13.1.1 A molded-rubber attachment plug or cord connector shall not show any apparent deterioration and shall show no greater change in hardness than ten numbers as the result of exposure for 70 hours in a full-draft circulating-air oven at a temperature of  $100.0 \pm 2.0^{\circ}\text{C}$  ( $212.0 \pm 1.8^{\circ}\text{F}$ ).

13.1.1 revised November 4, 1997

13.1.2 If possible, the complete device is to be tested. The hardness of the rubber is to be determined prior to testing as the average of five readings with an appropriate gauge such as the Rex Hardness Gauge or the Shore Durometer. The device is to be allowed to rest at room temperature for four or more hours after removal from the oven. The hardness is to be determined again as the average of five new readings. The difference between the average original hardness reading and the average reading taken after exposure to the heat conditioning is the change in hardness.

13.1.3 The accelerated-aging tests mentioned in 13.1.1 and 13.1.2 are to be made on each color of rubber and on each basic rubber compound employed for the device.

### 13.2 PVC compounds

13.2.1 A device having a body of molded plasticized polyvinyl chloride or a polyvinyl chloride copolymer thermoplastic elastomer shall not show any cracks, discoloration, or other visible signs of deterioration as the result of exposure for 96 hours in a full-draft circulating-air oven at a temperature of  $100.0 \pm 1.0^{\circ}\text{C}$  ( $212.0 \pm 1.8^{\circ}\text{F}$ ).

*Exception: A device having a body with a hardness of greater than Shore D65 as determined in accordance with ASTM D 2240 need not be subjected to this test.*

## 14 Mold Stress Relief Test

14.1 As a result of temperature conditioning as specified in 14.2, there shall not be any warpage, shrinkage or other distortion that results in any of the following:

- a) Making uninsulated live parts, other than exposed wiring terminals or internal wiring, accessible to contact by the probe shown in Figure 10.1.
- b) Defeating the integrity of the enclosure so that acceptable mechanical protection is not afforded to internal parts of the device.
- c) Interference with the operation, function, or installation of the device. The outlet openings of a female device shall be capable of having a mating male device of the intended configuration fully inserted.
- d) A reduction of spacing below the minimum acceptable values of 11.1 between an uninsulated live part and:
  - 1) an uninsulated live part of opposite polarity,

- 2) an uninsulated grounded metal part, or
  - 3) a non-current carrying metal part that is exposed to contact by persons when the device is installed and used in the intended manner.
- e) Any other evidence of damage that could increase the risk of fire or electric shock.

14.2 Fully assembled, unmated devices are to be placed in a full-draft circulating-air oven for seven hours. The temperature is to be maintained at a uniform temperature of not less than 70°C (158°F) and at least 10°C (18°F) higher than either:

- a) The maximum intended operating temperature of the device, up to the maximum thermal index rating of the insulating material, or
- b) The maximum temperature of the connector as measured during the Temperature Test, Section 16.

The devices are to be removed from the oven and allowed to cool to room temperature before determining compliance.

## 15 Overload Test

15.1 A female contact device shall perform acceptably when subjected to an overload test as described in 15.2 – 15.10. There shall not be any electrical or mechanical failure of the device nor pitting or burning of the contacts that would affect the intended function. The grounding fuse shall not open during the test.

*Exception No. 1: A Type 0 device need not be subjected to this test.*

*Exception No. 2: A device that is intended for disconnecting use only, not for current interruption, and is marked in accordance with 20.4, need not be subjected to this test.*

*Exception No. 3: A female contact device interlocked with an integral switch or other means such that the circuit is opened before a mating male contact device can be inserted or withdrawn need not be subjected to this test.*

15.2 Any additional material provided that is intended to reduce or confine the arcing in the contact chamber of the device, and that decomposes or is otherwise affected by the arcing, is to be removed for all of the overload tests.

15.3 A mating device is to be inserted and withdrawn manually or mechanically while connected to a suitable load. The equipment grounding contact is to be connected to ground through a fuse. The device is to make and break 150% of its rated current for 50 cycles of operation at a rate not higher than 10 cycles/min. The device is to be mounted and wired to represent actual service conditions. Exposed metal parts and any pole that is not part of the test circuit are to be connected through a fuse to ground or to the grounded conductor of the test circuit.

15.4 The fuse in the grounding circuit is to be a 15 A fuse if the device under test is rated 30 A or lower, and is to be a 30 A fuse if the device under test is rated at more than 30 A. The fuses in the test circuit are not to exceed the ampere rating of the device.

15.5 A previously untested male contact device is to be used for each overload test.

*Exception: One device may be used for all of the overload tests if agreeable to all concerned.*

15.6 Contacts of the device are not to be adjusted, lubricated, or otherwise conditioned before or during the test.

15.7 The potential of the test circuit is to be 95 to 105 percent of the voltage rating of the device.

15.8 A device that has multiple voltage and ampere ratings is to be tested at:

- a) 150% of the rated current that corresponds to the maximum rated voltage,
- b) 150% of the maximum rated current at the corresponding rated voltage, and
- c) 150% of the rated current at the corresponding rated voltage that results in the maximum power per pole.

15.9 A test using alternating current may be waived, if acceptable results have been obtained from an equivalent or higher volt-ampere test using a direct current voltage.

15.10 Alternating current is to be used if the device is rated for alternating current only. The power factor of the load is to be 0.75 to 0.80 for an ampere rated device.

## **16 Temperature Test**

16.1 The temperature of a device, when measured at the points described in 16.2 shall not exceed the Relative Thermal Index (electrical or mechanical without impact) of the insulating material when the device is carrying its maximum rated current.

*Exception: A Type 0 or Type 1A device not assigned a current rating need not be tested.*

16.2 The temperature measurement mentioned in 16.1 is to be made on the wiring terminals of each device if they are accessible for the mounting of thermocouples. If the wiring terminals are inaccessible, temperatures are to be measured as close as possible to the device current carrying contacts. The test is to continue for 4 hours even if stabilized temperatures are attained in a shorter period of time.

16.3 The test is to be conducted in accordance with the manufacturer's recommended wire size, pole location, and number of terminations.

16.4 Unless otherwise recommended by the manufacturer, all contacts are to be connected in series so as to carry the same test current. For connectors with groups of contacts with different electrical ratings, each group is to be wired as a separate series circuit and tested concurrently.

16.5 This test is to be made in a draft-free area having an ambient temperature of  $25 \pm 5^{\circ}\text{C}$  ( $77 \pm 9^{\circ}\text{F}$ ). Tests conducted at an ambient temperature other than  $25^{\circ}\text{C}$  are to have the test results adjusted to an ambient temperature of  $25^{\circ}\text{C}$  by adding the appropriate variation between  $25^{\circ}\text{C}$  and the ambient.



## 17 Dielectric Voltage-Withstand Test

17.1 Devices to be evaluated in accordance with the Exception to 11.1 are to be subjected to the test described in 17.2 – 17.4.

*Exception: Type 0 devices need not be tested.*

17.2 Immediately following the Temperature Test, the same devices shall withstand, without arc-over or breakdown, for a period of 1 minute, the application of an essentially sinusoidal potential at a frequency in the range of 40 – 70 Hz. The test potential shall be applied between live parts of opposite polarity and between live parts and exposed non-current-carrying metal parts.

17.3 The test potential is to be:

- a) 500 volts for a Type 1B device;
- b) 1000 volts plus twice rated voltage for Types 1A, 2, 3, and 4 devices.

17.3 revised October 18, 2002

17.4 The test potential is to be supplied from a 500 volt-ampere or larger capacity testing transformer whose output is essentially sinusoidal and can be varied. The applied potential is to be increased from zero until the required test voltage is reached, and is to be held at that voltage for a period of 1 minute. The increase in the applied potential is to be at a uniform rate and as rapid as is consistent with its value being correctly indicated by a voltmeter.

## 18 Resistance To Arcing Test

18.1 If an insulating material is used in the construction of the face of a female contact device in a way that the material is likely to be exposed to arcing while in service, the devices that were subjected to 50 cycles of operation in the test described in Overload Test, Section 15, shall perform acceptably when subjected to an additional 200 cycles of operation under the overload test conditions, following the temperature test. There shall not be any indication of electrical or mechanical failure, electrical tracking, formation of a permanent carbon path, or ignition of material.

*Exception No. 1: A Type 0 device need not be subjected to this test.*

*Exception No. 2: A device that is intended for disconnecting use, not for current interruption, and is marked in accordance with 20.4, need not be subjected to this test.*

*Exception No. 3: A female contact device interlocked with an integral switch or other means such that the circuit is opened before a mating male contact device can be inserted or withdrawn need not be subjected to this test.*

18.2 Alternatively, one set of devices may be subjected to the 50 cycles of operation described in Overload Test, Section 15, followed by the temperature test on the devices, and then, to determine resistance to arcing, a second previously untested set of devices may be subjected to 250 cycles of operation under the overload test conditions.

## 19 Conductor Secureness Test

19.1 The terminals of a device intended for crimp connection to individual leads shall be capable of withstanding a direct pull for a period of 1 min, without damage to the connection or separation of the conductor from the crimp. A pull of 20 lbf (89 N) is to be applied if the conductor is No. 18 AWG (0.82 mm<sup>2</sup>) or larger in size. If a smaller conductor is used, a pull of 8 lbf (36 N) is to be applied. The leads are to be assembled to the terminals in accordance with the manufacturer's recommendations. The pull is to be applied gradually and in the direction most likely to result in failure of the connection.

19.2 Six individual leads are to be tested. Leads from as many devices as necessary may be employed to achieve the required number.

*Exception: A terminal specified by the manufacturer as intended for crimp connection to a range of wire sizes is to be tested using six leads with the maximum and six with the minimum wire size.*

19.3 A device that is provided with more than one size of terminal is to have each size subjected to the test described in 19.2.

### 19A Flammability Test

Section 19A added December 12, 2000

19A.1 If a data, signal, control, or power connector is marked with a flammability class, the insulating material shall comply with the requirements and tests for the marked flammability classification as described in the Standard for Flammability of Plastic Materials for Parts in Devices and Appliances, UL 94.

## MARKINGS

### 20 General

20.1 A device shall be legibly marked, where visible before installation, with the manufacturer's trade name, trademark, or other descriptive marking by which the organization responsible for the product may be identified.

*Exception: If the device is too small, or where the legibility would be difficult to attain, the manufacturer's name, trade name, trademark, or other descriptive marking may appear on the smallest unit container or carton.*

20.2 The following shall be marked on the device or on the smallest unit container or carton or on a stuffer sheet in the smallest unit container or carton:

- a) The catalog number or an equivalent designation;
- b) The electrical rating in both volts and amperes, if assigned;
- c) Whether ac or dc, if restricted; and
- d) Flammability class, if identified.

20.2 revised December 12, 2000

20.3 If the same device is produced or assembled at more than one factory, each finished device shall have a distinctive marking, which may be in code, to identify the factory of origin.

*Exception: If the product is of a size such that legibility of the factory code designation would be difficult to attain, or if the construction or manufacturing process does not permit a legible factory code designation on each finished device, then the factory marking may instead be provided on the smallest unit container or carton.*

20.3 revised March 6, 1998

20.4 A device intended exclusively for disconnecting use may be marked "Not for current interrupting " or "For disconnecting use only " or with an equivalent statement.

20.4 revised November 4, 1997

No Text on This Page

## APPENDIX A

### Standards for Components

Standards under which components of the products covered by this standard are evaluated include the following:

Title of Standard – UL Standard Designation

---

Title of Standard – UL Standard Designation

Flammability of Plastic Materials for Parts in Devices & Appliances, Tests for – UL 94

Polymeric Materials – Short Term Property Evaluation – UL 746A

Polymeric Materials – Long Term Property Evaluation – UL 746B

Polymeric Materials – Use in Electrical Equipment Evaluations – UL746C

No Text on This Page