

# UL 1585

ISBN 0-7629-0233-7

## Class 2 and Class 3 Transformers



Underwriters Laboratories Inc. (UL)  
333 Pfingsten Road  
Northbrook, IL 60062-2096

UL Standard for Safety for Class 2 and Class 3 Transformers, UL 1585

Fourth Edition, Dated April 23, 1998

Revisions: This Standard contains revisions through and including February 10, 2004.

### ***Summary of Topics***

***These revisions to UL 1585 are being issued:***

***1. To incorporate new and revised requirements from the Subject 506 (1561, 1585) bulletin dated September 17, 2003;***

***2. To designate the standard as an American National Standard; and***

***3. To make editorial corrections in various requirements of the standard.***

UL Standards for Safety are developed and maintained in the Standard Generalized Markup Language (SGML). SGML -- an international standard (ISO 8879-1986) -- is a descriptive markup language that describes a document's structure and purpose, rather than its physical appearance on a page. Due to formatting differences resulting from the use of UL's new electronic publishing system, please note that additional pages (on which no requirements have been changed) may be included in revision pages due to relocation of existing text and reformatting of the Standard.

Text that has been changed in any manner is marked with a vertical line in the margin. Changes in requirements are marked with a vertical line in the margin and are followed by an effective date note indicating the date of publication or the date on which the changed requirement becomes effective.

The new and/or revised requirements are substantially in accordance with UL's Bulletin(s) on this subject dated September 17, 2003. The bulletin(s) is now obsolete and may be discarded.

The revisions dated February 10, 2004 include a reprinted title page (page1) for this Standard.

The revisions dated February 10, 2004 were issued:

1. To replace references to the defunct Standard for Wire Connectors and Soldering Lugs for Use with Copper Conductors, UL 486A, and the Standard for Wire Connectors for Use with Aluminum Conductors, UL 486B, in the standard with the Standard for Wire Connectors, UL 486A-UL 486B;
2. To replace references to the defunct Standard for Fuses for Supplementary Overcurrent Protection, UL 196G, with the Standard for Low-Voltage Fuses – Part 1: General Requirements – UL 248-1, and the Standard for Low-Voltage Fuses – Part 14: Supplemental Fuses – UL 248-14; and
3. To delete "No." from references to AWG wire size in various requirements in the standard.

As indicated on the title page (page 1), this UL Standard for Safety is an American National Standard. Attention is directed to the note on the title page of this Standard outlining the procedures to be followed to retain the approved text of this ANSI/UL Standard.

The master for this Standard at UL's Northbrook Office is the official document insofar as it relates to a UL service and the compliance of a product with respect to the requirements for that product and service, or if there are questions regarding the accuracy of this Standard.

UL's Standards for Safety are copyrighted by UL. Neither a printed copy of a Standard, nor the distribution diskette for a Standard-on-Diskette and the file for the Standard on the distribution diskette should be altered in any way. All of UL's Standards and all copyrights, ownerships, and rights regarding those Standards shall remain the sole and exclusive property of UL.

All rights reserved. No part of this publication may be reproduced, stored in a retrieval system, or transmitted in any form by any means, electronic, mechanical photocopying, recording, or otherwise without prior permission of UL.

Revisions of UL Standards for Safety are issued from time to time. A UL Standard for Safety is current only if it incorporates the most recently adopted revisions.

UL provides this Standard "as is" without warranty of any kind, either expressed or implied, including but not limited to, the implied warranties of merchantability or fitness for any purpose.

In no event will UL be liable for any special, incidental, consequential, indirect or similar damages, including loss of profits, lost savings, loss of data, or any other damages arising out of the use of or the inability to use this Standard, even if UL or an authorized UL representative has been advised of the possibility of such damage. In no event shall UL's liability for any damage ever exceed the price paid for this Standard, regardless of the form of the claim.

UL will attempt to answer support requests concerning electronic versions of its Standards. However, this support service is offered on a reasonable efforts basis only, and UL may not be able to resolve every support request. UL supports the electronic versions of its Standards only if they are used under the conditions and operating systems for which it is intended. UL's support policies may change from time-to-time without notification.

UL reserves the right to change the format, presentation, file types and formats, delivery methods and formats, and the like of both its printed and electronic Standards without prior notice.

Purchasers of the electronic versions of UL's Standards for Safety agree to defend, indemnify, and hold UL harmless from and against any loss, expense, liability, damage, claim, or judgement (including reasonable attorney's fees) resulting from any error or deviation introduced while purchaser is storing an electronic Standard on the purchaser's computer system.

If a single-user version electronic Standard was purchased, one copy of this Standard may be stored on the hard disk of a single personal computer, or on a single LAN file-server or the permanent storage device of a multiple-user computer in such a manner that this Standard may only be accessed by one user at a time and for which there is no possibility of multiple concurrent access.

If a multiple-user version electronic Standard was purchased, one copy of the Standard may be stored on a single LAN file-server, or on the permanent storage device of a multiple-user computer, or on an Intranet server. The number of concurrent users shall not exceed the number of users authorized.

Electronic Standards are intended for on-line use, such as for viewing the requirements of a Standard, conducting a word search, and the like. Only one copy of the Standard may be printed from each single-user version of an electronic Standard. Only one copy of the Standard may be printed for each authorized user of a multiple-user version of an electronic Standard. Because of differences in the computer/software/printer setup used by UL and those of electronic Standards purchasers, the printed copy obtained by a purchaser may not look exactly like the on-line screen view or the printed Standard.

An employee of an organization purchasing a UL Standard can make a copy of the page or pages being viewed for their own fair and/or practical internal use.

The requirements in this Standard are now in effect, except for those paragraphs, sections, tables, figures, and/or other elements of the Standard having future effective dates as indicated in the note following the affected item. The prior text for requirements that have been revised and that have a future effective date are located after the Standard, and are preceded by a "SUPERSEDED REQUIREMENTS" notice.

New product submittals made prior to a specified future effective date will be judged under all of the requirements in this Standard including those requirements with a specified future effective date, unless the applicant specifically requests that the product be judged under the current requirements. However, if the applicant elects this option, it should be noted that compliance with all the requirements in this Standard will be required as a condition of continued Listing, Recognition, and Follow-Up Services after the effective date, and understanding of this should be signified in writing.

Copyright © 2004 Underwriters Laboratories Inc.

This Standard consists of pages dated as shown in the following checklist:

Page	Date
1 .....	February 10, 2004
2-2A .....	February 28, 2001
2B .....	February 10, 2004
3 .....	February 28, 2001
4 .....	May 24, 1999
5-8B .....	February 28, 2001
9-10 .....	April 23, 1998
11 .....	February 28, 2001
12-12B .....	February 10, 2004
13 .....	February 28, 2001
14-15 .....	April 23, 1998
16-16B .....	February 10, 2004
17 .....	February 28, 2001
18-18A .....	February 10, 2004
18B-20 .....	February 28, 2001
21 .....	April 23, 1998
22 .....	February 10, 2004
23 .....	April 23, 1998
24-28B .....	February 28, 2001
29-30 .....	May 24, 1999
30A .....	February 28, 2001
30B-33 .....	May 24, 1999
34-34B .....	February 28, 2001
35-36 .....	February 10, 2004
37-38 .....	April 23, 1998
39-40 .....	May 24, 1999
40A .....	February 28, 2001
40B .....	May 24, 1999
41-42 .....	April 23, 1998
43-44 .....	February 28, 2001
45-46 .....	April 23, 1998
47-48B .....	February 28, 2001
49-50 .....	May 24, 1999
A1-A2 .....	February 10, 2004

**APRIL 23, 1998**  
(Title Page Reprinted: February 10, 2004)



**ANSI/UL 1585-2003**

1

**UL 1585**

**Standard for Class 2 and Class 3 Transformers**

Prior to the first edition, the requirements for Class 2 transformers were included in the Standard for Specialty Transformers, UL 506.

First Edition – March, 1982  
Second Edition – December, 1986  
Third Edition – April, 1993

**Fourth Edition**

**April 23, 1998**

The most recent designation of ANSI/UL 1585-2003 as an American National Standard (ANSI) occurred on November 25, 2003.

This ANSI/UL Standard for Safety, which consists of the Fourth Edition with revisions through February 10, 2004 is under continuous maintenance, whereby each revision is ANSI approved upon publication. Comments or proposals for revisions on any part of the Standard may be submitted to UL at any time. Written comments are to be sent to UL Santa Clara Standards Department, 1655 Scott Boulevard, Santa Clara, CA 95050.

An effective date included as a note immediately following certain requirements is one established by Underwriters Laboratories Inc.

Revisions of this Standard will be made by issuing revised or additional pages bearing their date of issue. A UL Standard is current only if it incorporates the most recently adopted revisions, all of which are itemized on the transmittal notice that accompanies the latest set of revised requirements.

**ISBN 0-7629-0233-7**

**COPYRIGHT © 1982, 2004 UNDERWRITERS LABORATORIES INC.**

No Text on This Page



**CONTENTS**

<b>FOREWORD</b> .....	4
-----------------------	---

**INTRODUCTION**

1 Scope .....	5
2 General .....	6
2.1 Components .....	6
2.2 Units of measurement .....	6
2.3 Undated references .....	7

**CONSTRUCTION**

3 General .....	7
4 Mechanical Assembly .....	8
5 Enclosure .....	8
6 Corrosion Resistance .....	9
7 Mounting .....	10
8 Wiring Space .....	10
9 Supply Connections .....	11
10 Primary Wiring Terminals .....	11
11 Primary Leads, Including Flexible Cords .....	12
12 Secondary Terminals and Leads .....	14
12.1 General .....	14
12.2 Class 3 transformers .....	15
13 Bushings .....	15
14 Internal Wiring .....	15
15 Grounding .....	15
16 Electrical Insulation .....	17
17 Coil Insulation .....	18
18 Protective Devices .....	18A
19 Separate Current-Limiting Impedances .....	18B
20 Separation of Internal Wiring Circuits .....	18B
21 Spacings .....	19

**PERFORMANCE**

22 General .....	22
23 Leakage Current Test .....	25
24 Leakage Current Test Following Humidity Conditioning .....	28
25 Grounding Continuity Test .....	28
26 Open-Circuit Secondary Voltage Test .....	28
27 Output Current and Power Test .....	29
27.1 Maximum output current of inherently limited transformers .....	29
27.2 Maximum current of not inherently limited transformers .....	31
27.3 Maximum power of not inherently limited transformers .....	32
28 Calibration Test of Overcurrent-Protective Devices .....	34
29 Rated Secondary Current Test .....	34A
30 Rated Output Heating Test .....	35
31 Dielectric Voltage-Withstand Test .....	38
31.1 General .....	38

31.2 Insulating barriers .....	38
31.3 Induced potential .....	38
32 Overload Heating Test .....	39
32.1 General .....	39
32.2 Procedure .....	39
33 Dielectric Voltage-Withstand After Overload Heating Test .....	41
34 Overload Test of Overcurrent- or Overtemperature-Protective Devices .....	42
35 Endurance Test of Automatically-Reset, Overtemperature-Protective Devices .....	42
36 Strain-Relief Test .....	43
36.1 Flexible cord .....	43
36.2 Leads .....	43
37 Outlet Box Cover Support and Impact Tests .....	43
37.1 General .....	43
37.2 Support .....	43
37.3 Impact .....	44

### **MANUFACTURING AND PRODUCTION TESTS**

38 Production-Line Dielectric Voltage-Withstand Test .....	46
39 Production-Line Grounding Continuity Test .....	47

### **RATINGS**

40 Details .....	47
------------------	----

### **MARKINGS**

41 Details .....	48
------------------	----

### **APPENDIX A**

Standards for Components.....	A1
-------------------------------	----

No Text on This Page

## FOREWORD

A. This Standard contains basic requirements for products covered by Underwriters Laboratories Inc. (UL) under its Follow-Up Service for this category within the limitations given below and in the Scope section of this Standard. These requirements are based upon sound engineering principles, research, records of tests and field experience, and an appreciation of the problems of manufacture, installation, and use derived from consultation with and information obtained from manufacturers, users, inspection authorities, and others having specialized experience. They are subject to revision as further experience and investigation may show is necessary or desirable.

B. The observance of the requirements of this Standard by a manufacturer is one of the conditions of the continued coverage of the manufacturer's product.

C. A product which complies with the text of this Standard will not necessarily be judged to comply with the Standard if, when examined and tested, it is found to have other features which impair the level of safety contemplated by these requirements.

D. A product employing materials or having forms of construction which conflict with specific requirements of the Standard cannot be judged to comply with the Standard. A product employing materials or having forms of construction not addressed by this Standard may be examined and tested according to the intent of the requirements and, if found to meet the intent of this Standard, may be judged to comply with the Standard.

E. UL, in performing its functions in accordance with its objectives, does not assume or undertake to discharge any responsibility of the manufacturer or any other party. The opinions and findings of UL represent its professional judgment given with due consideration to the necessary limitations of practical operation and state of the art at the time the Standard is processed. UL shall not be responsible to anyone for the use of or reliance upon this Standard by anyone. UL shall not incur any obligation or liability for damages, including consequential damages, arising out of or in connection with the use, interpretation of, or reliance upon this Standard.

F. Many tests required by the Standards of UL are inherently hazardous and adequate safeguards for personnel and property shall be employed in conducting such tests.

## INTRODUCTION

### 1 Scope

1.1 Transformers covered by these requirements, herein called Class 2 or Class 3 transformers, are for use with Class 2 or Class 3 circuits, respectively, in accordance with the National Electrical Code, ANSI/NFPA 70. They are intended for connection to essentially sinusoidal supply sources. Permanently connected transformers are rated 600 volts or less, and cord and plug connected transformers are rated 120 volts or less.

1.2 A Class 2 or Class 3 transformer that is inherently limited has an impedance within the transformer that limits the current output to a particular maximum value. It may or may not be provided with a thermostat or other temperature sensitive device to limit its maximum temperature.

1.3 A Class 2 or Class 3 transformer that is not inherently limited does not have an impedance to limit the maximum current output to a specified value. However, the maximum power output is limited by an overcurrent-protective device.

1.4 A Class 2 or Class 3 transformer that includes a separate current-limiting impedance, such as a resistor or a positive temperature coefficient device (PTC), is covered by these requirements.

1.5 A Class 2 transformer has a 30-volt rms maximum secondary potential under any condition of loading or open circuit.

1.6 A Class 2 or Class 3 transformer that includes a resonance regulating circuit is covered by these requirements.

1.7 These requirements do not cover power supplies, toy transformers, direct plug-in transformers, or transformers intended for use in audio-, radio-, or television-type appliances. A transformer provided with a rectifier is considered to be a power supply.

1.8 The requirements in this standard may be modified by requirements in an end product standard if a transformer is intended for use only as a component in other equipment.

1.9 A product that contains features, characteristics, components, materials, or systems new or different from those covered by the requirements in this standard, and that involves a risk of fire or of electric shock or injury to persons shall be evaluated using appropriate additional component and end-product requirements to maintain the level of safety as originally anticipated by the intent of this standard. A product whose features, characteristics, components, materials, or systems conflict with specific requirements or provisions of this standard does not comply with this standard. Revision of requirements shall be proposed and adopted in conformance with the methods employed for development, revision, and implementation of this standard.

1.9 revised February 28, 2001

## 2 General

### 2.1 Components

2.1.1 Except as indicated in 2.1.2, a component of a product covered by this standard shall comply with the requirements for that component. See Appendix A for a list of standards covering components used in the products covered by this standard.

2.1.1 revised February 28, 2001

2.1.2 A component is not required to comply with a specific requirement that:

- a) Involves a feature or characteristic not required in the application of the component in the product covered by this standard, or
- b) Is superseded by a requirement in this standard.

2.1.2 revised February 28, 2001

2.1.3 A component shall be used in accordance with its rating established for the intended conditions of use.

2.1.3 revised February 28, 2001

2.1.4 Specific components are incomplete in construction features or restricted in performance capabilities. Such components are intended for use only under limited conditions, such as certain temperatures not exceeding specified limits, and shall be used only under those specific conditions.

2.1.4 revised February 28, 2001

### 2.2 Units of measurement

2.2.1 Values stated without parentheses are the requirement. Values in parentheses are explanatory or approximate information.

2.2.1 revised February 28, 2001

2.2.2 Unless indicated otherwise, all voltage and current values mentioned in this standard are root-mean-square (rms).

## 2.3 Undated references

2.3.1 Any undated reference to a code or standard appearing in the requirements of this standard shall be interpreted as referring to the latest edition of that code or standard.

## CONSTRUCTION

### 3 General

3.1 A Class 2 or Class 3 transformer shall have only one secondary winding, which shall be insulated from the primary winding. A winding having intermediate taps is considered to be a single winding.

*Exception No. 1: Two or more secondary windings may be considered as a single winding. Interposing insulation between the secondary windings is not required if, when interconnected, the windings are in compliance with the performance requirements for a single-winding construction.*

*Exception No. 2: An inherently limited transformer marked in accordance with 41.7 may have two secondary windings that, when interconnected, are not in compliance with the performance requirements for a single-secondary winding construction.*

*Exception No. 3: A transformer intended only for use in other equipment may have multiple secondary windings only where isolation of all circuits can be maintained.*

3.2 There shall be no electrical connection between the primary and secondary windings of a transformer or between a primary or secondary circuit and the enclosure.

3.3 A component used to limit the output of a transformer to within the required current or power levels, or otherwise used to maintain its intended performance, shall have permanence and stability so as not to decrease its limiting capabilities. Among the factors taken into consideration when judging the acceptability of a limiting component are the:

- a) Operating temperature;
- b) Electrical stress level;
- c) Transient surges; and
- d) Resistance to moisture.

## 4 Mechanical Assembly

4.1 A transformer shall be formed and assembled so that it has the strength and rigidity necessary to resist the abuses to which it is likely to be subjected. A risk of fire, electric shock, or injury to persons shall not result from a reduction of spacings, loosening or displacement of parts, or other serious defects due to total or partial collapse of the transformer.

4.2 An adhesive used in the assembly of the enclosure shall be investigated as specified in the Standard for Polymeric Materials – Use in Electrical Equipment Evaluations, UL 746C.

*Exception: Methods utilizing fusion techniques, such as solvent cementing, ultrasonic welding, electromagnetic induction, and thermal welding, need not be investigated.*

## 5 Enclosure

5.1 A transformer shall be provided with an enclosure of sheet steel, sheet aluminum, cast aluminum, cast iron, or equivalent metal, or a polymeric material. The enclosure shall contain all uninsulated live parts and primary circuit wiring.

*Exception No. 1: The secondary terminals of a Class 2 transformer need not be enclosed.*

*Exception No. 2: For a transformer mounted on an outlet box cover or intended for mounting in a knockout of an outlet box or cabinet, the primary terminals or leads are considered to be enclosed by the outlet box or cabinet.*

*Exception No. 3: A Class 3 transformer may be provided with a flexible cord and attachment plug for connection to the source of supply.*

*Exception No. 4: A transformer may have exposed primary leads when intended for connection to open wiring or concealed knob-and-tube wiring.*

*Exception No. 5: The enclosure of the end product may serve as the transformer enclosure for a transformer intended for use only in other equipment. However, the primary and secondary wiring of the transformer shall be separated in accordance with the requirements for the end product.*

5.1 revised February 28, 2001

5.2 The transformer shall be constructed so that it can be mounted and wired as intended in the field without exposing internal parts such as windings and protective devices to damage. All covers, bases, and similar parts shall be securely fastened in place.

5.3 An enclosure of a transformer that has a flexible cord connected to the primary shall have no opening where a 0.010 inch (0.25 mm) diameter rigid wire, such as a music wire, can be inserted to contact a part at a potential of more than 42.2 volts peak to any other part or to ground. A single bend in the wire is permitted prior to insertion, and a barrier that can be penetrated by the wire is not acceptable as a protective barrier. An indicating circuit connected to the wire probe may be used to determine if contact is made.

*Exception: This requirement does not apply to an outlet box that may be provided only to enclose the primary leads or terminals as described in Exception No. 2 to 5.1*



5.4 An edge, projection, or corner of an enclosure, opening, or frame of a transformer shall be smooth and not cause a cut-type injury when contacted during intended use or maintenance.

5.5 Among the factors that shall be taken into consideration when evaluating magnesium and nonmetallic materials other than a polymeric material are:

- a) Mechanical strength;
- b) Resistance to impact;
- c) Moisture absorption;
- d) Combustibility; and
- e) Resistance to distortion at temperatures to which the material may be subjected under conditions of intended or abnormal use.

5.6 Polymeric materials shall comply with the applicable requirements in the Standard for Polymeric Materials – Use in Electrical Equipment Evaluations, UL 746C.

5.7 A sheet steel enclosure shall be formed from stock having a thickness of not less than 0.026 inch (0.66 mm) when uncoated, or 0.029 inch (0.74 mm) when zinc coated.

*Exception: Sheet steel having a thickness of not less than 0.020 inch (0.51 mm) if uncoated, or 0.023 inch (0.58 mm) if zinc coated, may be used for drawn end bells having maximum dimensions of 2-1/4 inches (57.2 mm) on the flat portion and 1-1/2 inches (38.1 mm) at the base of the drawn portion. Figure 5.1 illustrates these portions of an end bell.*

5.8 The thickness of a steel sheet is determined by taking five micrometer readings equally spaced across the full width of the sheet as rolled.

5.9 An enclosure of nonferrous sheet metal shall be formed from stock having a thickness of not less than 0.040 inch (1.07 mm).

5.10 An enclosure of cast iron or aluminum shall not be less than 1/8 inch (3.2 mm) thick at any point.

*Exception: A section 2 square inches (12.9 cm<sup>2</sup>) or less in area shall not be less than 1/16 inch (1.6 mm) thick, when the sum of the areas of all such sections is less than 50 percent of the total area of the enclosure.*

5.11 An enclosure of cast iron shall not be less than 1/4 inch (6.4 mm) thick at tapped holes for conduit.

No Text on This Page

**Figure 5.1**  
**End bell**

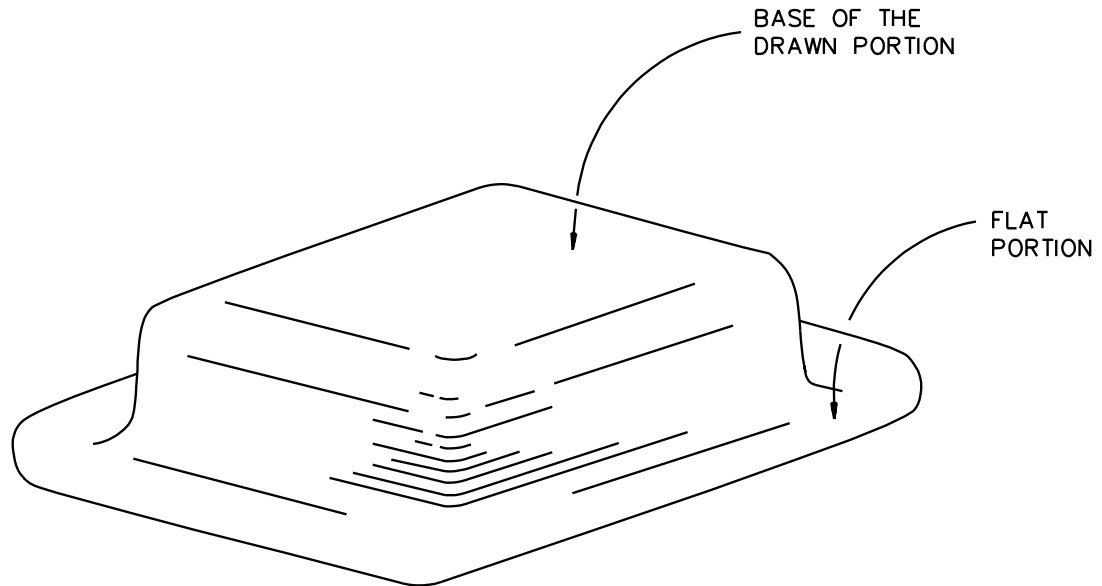

S-2008

5.12 When threads for the connection of conduit are tapped all the way through a hole in a transformer enclosure, or if a similar construction is used, there shall not be less than 3-1/2 nor more than 5 threads in the metal. The construction shall enable the proper and secure attachment of a standard conduit bushing.

5.13 When threads for the connection of conduit are tapped only part of the way through a hole in the enclosure, there shall not be less than 5 full threads in the metal. There shall be a smooth, well-rounded inlet hole to provide a passage similar to that provided by a standard conduit bushing.

5.14 A transformer intended to be supported by rigid metal conduit shall have conduit hubs with not less than 5 full threads.

5.15 A knockout for the connection of rigid metal conduit to a terminal or wiring compartment of a transformer shall have a diameter in accordance with the requirements in the Standard for Nonmetallic Outlet Boxes, Flush-Device Boxes, and Covers, UL 514C.

5.16 When a nipple is provided on the primary side for connection to an outlet box, there shall be not less than 3-1/2 threads on the nipple.

## **6 Corrosion Resistance**

6.1 An enclosure of iron or steel, other than stainless steel, shall be corrosion resistant. Galvanizing, plating, varnishing, and painting are among the acceptable means for providing corrosion resistance.

*Exception: An interior surface covered by a compound need not be additionally resistant to corrosion.*

## 7 Mounting

7.1 A transformer not intended to be portable shall be provided with a secure mounting means. It shall be constructed so that there will be a spacing through air of not less than 1/4 inch (6.4 mm) between the supporting surface and the enclosure when the device is mounted on a plane surface.

*Exception No. 1: A transformer mounted on an outlet box cover or intended for mounting in a knockout of an outlet box or cabinet need not have an air spacing between the supporting surface and the transformer enclosure.*

*Exception No. 2: A transformer intended for use only in other equipment as described in Exception No. 5 to 5.1 need not be provided with the 1/4 inch spacing.*

7.2 A transformer intended to cover an outlet box shall be equipped with a cover that is resistant to corrosion on all surfaces.

7.3 When an outlet box cover is constructed of sheet steel, it shall have a thickness not less than 0.045 inch (1.14 mm) when zinc coated, and 0.042 inch (1.07 mm) when uncoated. When constructed of malleable iron, the cover shall have a wall thickness of not less than 3/32 inch (2.4 mm). When constructed of another type of cast metal, the thickness shall not be less than 1/8 inch (3.2 mm). Covers constructed of sheet aluminum, copper, or brass, shall not be less than 0.058 inch (1.47 mm) thick.

7.4 If the cover mentioned in 7.2 is of nonmetallic material, it shall be strong enough to:

- a) Support a weight three times the weight of the transformer, as described in 37.2.1, without cracking or crazing;
- b) Withstand an impact of 5 foot-pounds (6.8J) applied as described in 37.3.1; and
- c) Comply with the requirements for nonmetallic box covers in the Standard for Nonmetallic Outlet Boxes, Flush-Device Boxes, and Covers, UL 514C.

7.5 A transformer intended for mounting in place of a knockout in an outlet box, cabinet, or similar area, shall be provided with mounting means that will restrain the transformer from being turned after it is mounted.

7.6 A transformer is considered to comply with the requirement in 7.5 when the mounting means provides restraint against turning when the transformer is mounted in a box or cabinet wall having a minimum uncoated thickness of 0.053 inch (1.35 mm).

## 8 Wiring Space

8.1 A transformer shall be provided with an enclosure which provides space for the installation of those conductors likely to be used to connect the primary and secondary circuits.

*Exception No. 1: The secondary terminals or leads of a Class 2 transformer do not have to be enclosed.*

*Exception No. 2: The following do not have to be enclosed by the transformer enclosure:*

- a) *The primary terminals or leads of a transformer mounted on an outlet box cover;*
- b) *The primary leads of a transformer intended for mounting in a knockout; or*

*c) The primary leads of a transformer intended for installation with open wiring or concealed knob-and-tube wiring.*

*Exception No. 3: Wiring space does not have to be provided for a transformer intended only for use in other equipment as described in Exception No. 5 to 5.1.*

8.2 There shall be space provided within a terminal or wiring compartment for a standard conduit bushing to be mounted on rigid metal conduit connected to the compartment.

8.3 A wiring space or compartment intended to enclose wires shall be free of any sharp edge, burr, fin, moving part, or similar item that may abrade the insulation on conductors or otherwise damage the wiring.

## **9 Supply Connections**

9.1 The supply connection facilities of a transformer shall consist of insulated wire leads, terminals, or, for a Class 3 transformer, flexible cord with an attachment plug for plugging into a receptacle outlet.

9.1 revised February 28, 2001

## **10 Primary Wiring Terminals**

10.1 For the purpose of these requirements, a wiring terminal is that terminal to which a connection is made in the field when a transformer is installed. A terminal shall be a pressure terminal connector, a wire-binding screw, or a stud.

10.2 When a Class 2 transformer is intended for mounting on an outlet box, wiring terminals that will be inside the box after the transformer is installed shall be located or recessed so that contact between the terminals and wires inside the box will be unlikely after the transformer is installed.

10.3 A wire-binding screw terminal design is one in which the conductor is intended to encircle the terminal screw at least 3/4 of one full turn without overlapping.

10.4 A wire-binding screw shall thread into metal.

10.5 The terminal plate and the wire-binding screw or stud and nut of a primary wiring terminal shall be brass or similar nonferrous metal.

*Exception: A No. 10 (4.8 mm) or larger wire-binding screw may be iron or steel if plated. A steel wire-binding screw shall not be plated with copper or brass; however, a cadmium or zinc plating is acceptable.*

10.6 A terminal plate for a wire-binding screw shall be not less than 0.030 inch (0.76 mm) thick and shall have not less than two full threads in the metal for the binding screw.

10.7 Wire-binding screws or studs shall be not smaller than No. 6 (3.5 mm) and shall not have more than 32 threads per inch (25.4 mm).

10.8 A wire-binding screw shall be captivated (locked into position) if replacement with a longer screw would create a risk of fire or electric shock.

10.9 Wiring terminals shall be provided with cupped washers, upturned lugs, or equivalent means to retain the wires under the heads of the screws or nuts.

10.10 Terminal studs shall be prevented from turning by means other than friction between mounting surfaces. The acceptability of the use of lock washers to prevent turning of terminals shall be determined by means of an investigation.

10.11 Pressure terminal connectors shall comply with the Standard for Wire Connectors, UL 486A-UL 486B or the Standard for Equipment Wiring Terminals for Use with Aluminum and/or Copper Conductors, UL 486E.

10.11 revised February 10, 2004

10.12 A pressure terminal connector shall be prevented from turning by a restraint such as a shoulder or boss. A lock washer alone is not acceptable for this purpose.

*Exception: A means to prevent turning need not be provided when spacings are not less than those specified in Spacings, Section 21, with:*

- a) Connectors of opposite polarity turned 30 degrees toward each other or
- b) A connector turned 30 degrees toward any other opposite polarity live part or dead metal part.

## 11 Primary Leads, Including Flexible Cords

11.1 The connection between a primary lead, including a flexible cord, and the winding or other part of the transformer shall be:

- a) Secured by means of a pressure wire connector or
- b) Soldered, welded, or brazed.

A soldered joint shall be made mechanically secure before being soldered.

*Exception: Additional mechanical security is not required when a lead is rigidly held in place without the use of solder, or if it will be retained in place by compound or equivalent means.*

11.2 A primary field wiring lead of a transformer intended for permanent connection shall have stranded copper conductors not smaller than 18 AWG (0.82 mm<sup>2</sup>).

11.2 revised February 10, 2004

11.3 Insulation of a primary lead shall be at least 0.030 inch (0.76 mm) thick.

11.4 Thermoplastic insulated wire and flexible cord shall not be used for a transformer lead unless it has been investigated to be acceptable. The investigation is to consider the strain-relief employed, and the effects of the varnishing and compounding operations on the insulation of the lead.

11.5 A transformer lead shall have a voltage and temperature rating appropriate for the application. In a Class 130(B) or higher insulation system, a lead shall be additionally investigated in accordance with the requirements in the Standard for Systems of Insulating Materials – General, UL 1446.

11.6 A primary field wiring lead of a transformer for permanent connection shall extend not less than 6 inches (152 mm) outside the enclosure, and a lead of 18 or 16 AWG (0.82 or 1.3 mm<sup>2</sup>) wire shall extend not more than 12 inches (305 mm) outside the enclosure.

11.6 revised February 10, 2004

11.7 An insulating bushing or a smooth, well-rounded opening shall be provided where the primary leads pass through the enclosure of a permanently wired transformer.

11.8 A transformer intended for installation with open wiring or concealed knob-and-tube wiring in accordance with Articles 320 and 324 respectively of the National Electrical Code, ANSI/NFPA 70, shall be provided with the following:

- a) A marking in accordance with 41.18;
- b) A spacing of not less than 1/4 inch (6.4 mm) between the conductors;
- c) A spacing of not less than 1/2 inch (12.7 mm) between the conductors and the plane of the transformer support; and
- d) An insulating bushing where the primary leads pass through the enclosure. Either a separate hole for each lead shall be provided in the insulating material or separate bushings shall be provided.

11.8 revised May 24, 1999

11.9 Strain-relief shall be provided so that stress on a flexible cord or a lead intended for connection to field wiring will not be transmitted to the connection inside the transformer. Strain-relief shall be investigated in accordance with the Strain-Relief Test, Section 36.

11.10 A strain-relief means that depends solely on adhesion between the conductor and an asphalt-type compound shall not be used. Epoxy- and polyester-type compounds may be used for strain-relief when the construction complies with the Strain-Relief Test, Section 36.

11.11 Flexible cord, when provided with a Class 3 transformer, shall be:

- a) Not less than 5 feet (1.52 m) nor more than 10 feet (3.05 m) in length;
- b) Connected to an attachment plug rated at 15 amperes; and
- c) A type specified in 11.13.

11.11 revised February 28, 2001

11.12 The length of flexible cord is to be measured from the face of the attachment plug to the point where the cord emerges from the transformer enclosure.

11.13 The types of flexible cord for use with a portable Class 3 transformer are indicated in Table 11.1. They are listed from lightest to heaviest, in order, with respect to general serviceability. Where these requirements specify any particular type of flexible cord, all types following it in the table are also acceptable.

11.13 revised February 28, 2001



No Text on This Page

**Table 11.1**  
**Acceptable types of cord**

SP-2	
SP-3	
SPE-2	
SPE-3	
SPT-2	
SPT-3	
SV	SJO, SJOO
SVE	SJT
SVO, SVOO	SJTO, SJTOO
SVT	S
SVTO, SVTOO	SO, SE, SOO
SJ	ST
SJE	STO, STOO

## 12 Secondary Terminals and Leads

### 12.1 General

12.1.1 Wiring terminals, quick-connect terminals, or insulated leads shall be provided for secondary circuit connection.

12.1.2 A nominal 0.110-, 0.125-, 0.187-, 0.205-, or 0.250-inch wide, quick-connect terminal shall comply with the Standard for Electrical Quick-Connect Terminals, UL 310. Other sizes of quick-connect terminals shall be investigated with respect to crimp pull-out, engagement-disengagement forces of the connector and tab, and temperature rise. All tests shall be conducted in accordance with UL 310.

12.1.3 When a quick-connect terminal is provided, the maximum ampere rating of the coil shall be 5 amperes for a terminal tab with a nominal width of 0.125 inch (3.2 mm) or less. The maximum ampere rating of the coil shall be 24 amperes for a terminal tab with a nominal width greater than 0.125 inch.

12.1.4 Terminal plates, wire-binding screws, studs, and nuts shall be constructed as specified for Primary Wiring Terminals, Section 10.

*Exception No. 1: The terminal plates may be of plated steel; cupped washers and similar devices are not required.*

*Exception No. 2: A No. 4 (2.8 mm diameter) wire-binding screw with not more than 40 threads per inch may be used for a secondary terminal of a Class 2 transformer.*

12.1.5 The insulation of secondary circuits of a transformer shall be equivalent to that required for the primary circuit of the transformer, or the secondary circuits shall be separated from all wiring of different circuits by routing, clamping, the use of one or more barriers, or equivalent means.

12.1.6 Other than as required in 12.1.5, the type and thickness of insulation is not specified for leads and flexible cord on the load side of required energy-limited components. The leads and flexible cord may be any length.

12.1.7 A fitting having female contacts shall be constructed so that it will not receive the blades of a standard attachment plug as described in the Standard for Attachment Plugs and Receptacles, UL 498. A fitting having male contacts shall be constructed so that the contacts will not touch a live part of a standard attachment-plug receptacle.

12.1.8 Regarding 12.1.7, the output cord or leads of a unit for use as a Class 2 transformer are not required to be terminated in a fitting; however, when a fitting is provided, it shall comply with the requirements in 12.1.7.

## **12.2 Class 3 transformers**

12.2.1 Class 3 secondary terminals and leads shall comply with the requirements for primary terminals and leads in Primary Leads, Including Flexible Cords, Section 11. Class 3 secondary leads that terminate in a fitting shall comply with 12.1.7 in addition to the requirements in Section 11.

## **13 Bushings**

13.1 Other than as specified in 11.7, at a point where a wire of a flexible cord passes or is intended to pass through an opening in a metal wall, barrier, or enclosure, there shall be an insulating bushing or the equivalent secured in place that has a smooth, rounded surface against which the wire or cord may bear. An insulating or metal bushing or the equivalent shall be used with a primary circuit flexible cord.

13.2 A fiber bushing shall have a wall thickness not less than 3/64 inch (1.2 mm) and shall be formed and secured in place so that it will not be affected adversely by conditions of moisture or intended use. A fiber plate not less than 1/32 inch (0.8 mm) thick, with a punched hole, may be used instead of a bushing if the cord or wire is tightly bunched and firmly held in position.

13.3 Bushings of rubber, wood, or hot-molded shellac or tar compositions shall not be used.

## **14 Internal Wiring**

14.1 The internal wiring of a transformer shall be rated for the temperature, voltage, and other conditions of use to which it will be subjected.

14.2 Aluminum conductors, insulated or uninsulated, used for internal interconnections between current-carrying parts, shall be terminated at each end by a method that has been determined to be acceptable for the combination of metals at the connection points.

## **15 Grounding**

15.1 All exposed dead metal parts shall be bonded together and to a grounding means provided for the connection of a grounding conductor of a nonmetallic sheathed cable when a transformer is:

- a) Equipped with a wiring compartment;
- b) Mounted on a nonmetallic outlet box cover; or

- c) Intended for mounting on an outlet box provided with a nonmetallic cover.

The grounding means shall be a grounding screw, a threaded grounding stud, a grounding wire connector, or a grounding wire and shall be identified by the color green or by the designation "G," "GR," "GND," "Ground," or the equivalent. The following symbol may be used for this purpose. ⊕ When used alone, the symbol shall be defined in instructions provided with the transformer.

15.2 When a grounding screw is provided, it shall be No. 8-32 (4.2 mm diameter) or larger and shall have a head that is slotted, hexagonal, or both. When it threads into aluminum, the grounding screw shall be plated steel or stainless steel. When it threads into any other material, the grounding screw shall be plated steel, stainless steel, copper, or copper alloy. A grounding screw shall engage at least two full threads and shall be provided with upturned lugs or the equivalent to hold the conductor under the screw.

15.3 When a threaded grounding stud is provided, it shall be No. 8-32 (4.2 mm diameter) or larger. Studs shall be secured by threading, welding, brazing, or equivalent securement means. When it threads into aluminum, the grounding stud shall be plated steel or stainless steel. When it threads into any other material, the grounding stud shall be plated steel, stainless steel, copper, or copper alloy. A threaded grounding stud shall be provided with a nut and cupped washer with upturned edges or the equivalent to hold the conductor under the nut head.

15.4 When a grounding wire connector is provided, it shall be a pressure wire connector sized to accept a minimum 14 AWG (2.1 mm<sup>2</sup>) copper conductor.

15.4 revised February 10, 2004

15.5 When a grounding wire is provided, it shall be at least 14 AWG (2.1 mm<sup>2</sup>) and shall be either bare, covered, or insulated solid or stranded copper. When covered or insulated, the covering or insulation shall be green with or without one or more yellow stripes, and no other lead shall be so identified. The grounding wire shall not be less than 6 inches (152 mm) long.

*Exception: When the primary leads are smaller than 14 AWG, the grounding wire may be no smaller than the primary leads.*

15.5 revised February 10, 2004

15.6 When a transformer is intended for connection to open wiring or concealed knob-and-tube wiring, a grounding means as described in 15.1 shall be provided on the enclosure.

15.7 When a transformer intended for mounting on an outlet box is provided with a metal cover, all exposed dead metal parts shall be bonded to the cover.

15.8 When a transformer is intended for mounting in a knockout, all exposed dead metal parts shall be bonded to the mounting means. If there is no means for maintaining a bonding path between the transformer and the equipment grounding conductor when the transformer is installed in a nonmetallic box, the transformer shall be marked in accordance with 41.19.

15.9 When a Class 3 transformer is cord-connected, all accessible dead metal parts that are likely to be energized by the primary circuit shall be bonded together and to the equipment grounding conductor of the cord. The equipment grounding conductor shall be attached to the grounding blade of a grounding type attachment plug.

*Exception: Grounding is not necessary when the transformer enclosure is nonmetallic and there are no accessible metal parts that are likely to be energized by the primary circuit.*

15.9 revised February 28, 2001

No Text on This Page

15.10 The grounding path, when ferrous, shall be resistant to corrosion by varnishing, painting, galvanizing, plating, or the equivalent. A grounding connection may include a metal enclosure, or wires or similar device completely within the enclosure. When a separate conductor is used, it shall not be secured by a removable fastener used for any purpose other than grounding, unless the conductor is unlikely to be omitted after removal and replacement of the fastener. The ends of the conductor shall be in metal-to-metal contact with the parts to be bonded.

15.11 A solder splice shall not be employed in a wire used for bonding purposes.

15.12 In a Class 3 transformer provided with a flexible cord, the impedance at 60 hertz and the thermal capacity between the connection point of the equipment grounding means and any other metal part required to be grounded shall be such that the construction complies with the test specified in 25.1.

15.12 revised February 28, 2001

15.13 A Class 2 or 3 transformer need not be grounded when it:

- a) Is provided with double insulation between primary and secondary circuits and between primary circuits and exposed dead metal parts and
- b) Complies with the requirements in the Standard for Double Insulation Systems for Use in Electrical Equipment, UL 1097.

15.13 added February 28, 2001

## 16 Electrical Insulation

16.1 An insulating material used for direct or indirect support of live parts shall provide the levels of performance specified in the requirements for direct and indirect support of live parts in the Standard for Polymeric Materials – Use in Electrical Equipment Evaluations, UL 746C.

16.2 Vulcanized fiber may be used for insulating bushings, washers, separators, and barriers, but not as the sole support of uninsulated live parts.

*Exception: Vulcanized fiber may be used for mounting of the low voltage terminals of a Class 2 transformer, or for material used for separators, spacers, coil supports, and similar parts within a transformer enclosure.*

## 17 Coil Insulation

17.1 A coil shall be provided with insulation between the:

- a) Various windings,
- b) Windings and the core,
- c) Windings and the enclosure, and
- d) Primary crossover lead and adjacent windings.

*Exception No. 1: Interposing insulation between two or more secondary windings is not required if the windings, when interconnected, are in compliance with the performance requirements for a single-winding construction.*

*Exception No. 2: Insulation between the windings as noted above is not required when the spacings specified in Spacings, Section 21, are provided.*

17.2 Coil insulation, unless inherently moisture-resistant, shall be treated to render it resistant to moisture. Film-coated magnet wire is not required to be additionally treated to resist moisture absorption.

17.3 When a coil operates above the limit for Class 105 insulation during the rated output heating test at rated current, the coil insulation provided in accordance with 21.4 shall comply with the requirements in the Standard for Systems of Insulating Materials – General, UL 1446, for the temperature rating involved.

17.4 Coil insulating materials used in a transformer insulation system that is not rated Class 130 or higher shall have an electrical relative thermal index not less than 105°C (221°F), as determined by the requirements in the Standard for Polymeric Materials – Long Term Property Evaluations, UL 746B.

*Exception No. 1: Electrical grade paper as described in 21.4 need not have an electrical relative thermal index.*

*Exception No. 2: Insulating materials used as insulation in areas other than between primary and secondary windings and the primary or secondary windings and core need not have an electrical relative thermal index.*

*Exception No. 3: Magnet wire insulation need not have an electrical relative thermal index.*

17.5 The layer of insulating material between the primary and secondary windings on a flanged, bobbin wound transformer, on which the windings are wound one on top of the other, shall have a continuous bent-up edge against both bobbin end-flanges. The height of the bent-up edge shall not be less than 1/32 inch (0.8 mm).

17.6 A molded bobbin transformer having a slot or slots for the magnet coil crossover or start lead without a splice at the windings need not incorporate a slot fill if the transformer withstands the induced potential test described in 31.3.1 – 31.3.3.

17.6 revised February 10, 2004



## 18 Protective Devices

18.1 Protective devices include fuses, over-temperature and overcurrent protectors, thermal protectors, eutectic material, and similar devices intended to interrupt the flow of current as a result of overload, overtemperature, or overload and overtemperature.

18.1 revised February 10, 2004

18.2 Crossed or reduced cross-section conductors shall not be used as a protective device. A nicked conductor is a form of reduced cross-section conductor.

18.3 Operation of a thermal cutoff in a transformer shall not cause a risk of fire or electric shock during intended use. When relied upon to comply with the requirements in this standard, a thermal cutoff shall comply with the requirements in the Standard for Thermal Cutoffs for Use in Electrical Appliances and Components, UL 1020. A thermal cutoff is a temperature or temperature and current sensitive device intended to interrupt a current flow at a predetermined temperature and is intended only for single operation – it shall not be reset or reconditioned for reuse.

18.4 A manually-reset type of protective device shall be constructed so that automatic tripping is not prevented by any setting or position of the reset mechanism.

18.5 An automatically- or manually-reset protective device or a replaceable, overcurrent-protective device shall not open when the transformer is delivering its rated output as described in the Rated Secondary Current Test, Section 29, and the Rated Output Heating Test, Section 30.

18.6 A protective device shall be located inside the transformer enclosure. The device shall be inaccessible to tampering.

*Exception No. 1: A transformer may be provided with a replaceable, overcurrent-protective device. When the device is relied upon for compliance with requirements in this standard, it shall not be interchangeable with a device having a higher current rating, and the transformer shall be marked in accordance with 41.14.*

*Exception No. 2: The reset button or handle of a manually-reset device need not be located inside the enclosure.*

*Exception No. 3: For a transformer intended only for use in other equipment, as described in Exception No. 5 to 5.1, the protective device may be located inside the enclosure of the end product.*

18.7 When a Class 2 or Class 3 transformer does not comply with the current limitations of an inherently limited power source in Table 27.3, it shall comply with the current and power limitation of a not inherently limited power source as described in the table. Additionally, the transformer shall be provided with overcurrent protection in accordance with the Calibration Test of Overcurrent-Protective Devices, Section 28.

18.8 An overcurrent-protective device provided to comply with 18.7 shall not be an automatic reclosing type. When an accessible control of a manual-reset, overcurrent-protective device is held in the on or reset position, and the protective device is automatically tripped, the contact shall not automatically return to the closed position.

18.9 When a replaceable type of overcurrent-protective device (such as a fuse) is provided to comply with 18.7, the device shall not be interchangeable with a device having a higher current rating.

18.10 An overcurrent device shall be rated in accordance with Table 27.3 and shall comply with the Calibration Test of Overcurrent-Protective Devices, Section 28.

## 19 Separate Current-Limiting Impedances

19.1 Separate current-limiting impedances such as resistors or positive temperature coefficient devices (PTCs) may be provided.

## 20 Separation of Internal Wiring Circuits

20.1 Unless provided with insulation rated for the highest voltage involved, insulated conductors of different circuits shall be separated by barriers or shall be segregated and shall be separated or segregated from uninsulated live parts connected to different circuits. The end product may provide this separation for transformers intended for use only in other equipment as described in Exception No. 5 to 5.1.

20.2 Segregation of insulated conductors shall be accomplished by clamping, routing, or an equivalent means that provides permanent separation from insulated or uninsulated live parts of a different circuit.

20.3 A barrier used to separate or segregate internal wiring, or used to separate or segregate low voltage field wiring from line voltage parts, shall have mechanical strength. It shall be held in place to provide permanent separation and shall be rated for the temperature involved.

20.4 An insulating barrier shall have a minimum thickness of 0.028 inch (0.71 mm) and shall be of material as described in Electrical Insulation, Section 16.

20.5 In a compartment or enclosure where provision for Class 1 power, lighting, non-power limited fire alarm, or medium power network-powered broadband communication circuit conductors (as defined in the National Electrical Code, ANSI/NFPA 70) is available for connection to Class 2 or 3 circuits, Class 2 and 3 circuit conductors may be separated from the conductors of other circuits by the following methods:

- a) A reliable barrier, clamping or routing means that maintains a minimum spacing of 1/4 inch (6.4 mm) between the conductors of different circuits or
- b) When all circuit conductors operate at 150 volts or less to ground, the Class 2 and Class 3 circuits may be installed using minimum CL3, CL3R, CL3P, or cables determined equivalent. These cables shall extend beyond the jacket and be separated by a minimum of 1/4 inch (6.4 mm) or by an insulating sleeve or barrier from all other conductors.

20.5 added February 28, 2001

## 21 Spacings

21.1 At primary wiring terminals, the spacing through air or over surface between uninsulated live parts of opposite polarity, and between an uninsulated live part and a dead metal part that may be grounded, shall not be less than:

- a) 1/2 inch (12.7 mm), when the primary voltage rating is 250 volts or less and
- b) 1 inch (25.4 mm), when the primary voltage rating exceeds 250 volts.

21.2 At points other than primary wiring terminals, the spacings between uninsulated live parts of opposite polarity, and between an uninsulated live part and a dead metal part shall not be less than those shown in Table 21.1.

*Exception No. 1: Spacings need not be provided between turns of the same coil.*

*Exception No. 2: Spacings at a point in the secondary circuit may be less than those specified in Table 21.1 when the transformer is marked "Class 2" or "Class 2 Not Wet, Class 3 Wet" and the transformer complies with the requirements in Sections 23 – 28 and 31 – 33 with a short-circuit introduced at the point of reduced spacing.*

*Exception No. 3: Spacings between the primary and secondary windings of a flanged bobbin-wound transformer within a nonventilated enclosure, as measured across the bobbin surface between the windings, may be as specified in Table 21.2.*

*Exception No. 4: When spacings within a transformer coil (excluding the terminals) are reliably maintained by means such as varnishing or impregnation, the spacings in Table 21.3 may be used.*

*Exception No. 5: Spacings may be less than the spacings specified in Table 21.1 if the insulating material is provided in accordance with 21.4.*

**Table 21.1**  
**Minimum acceptable spacings elsewhere than at primary wiring terminals**

Potential involved, volts	Through air,		Over surface, <sup>a</sup>	
	inch	(mm)	inch	(mm)
50 or less	1/16	1.6	1/16	1.6
51 – 150	1/8	3.2	1/4	6.4
151 – 250	1/4	6.4	3/8	9.5
251 – 600	3/8	9.5	1/2	12.7

NOTE – An isolated part of conductive material (such as a screw head or washer) interposed between uninsulated live parts of opposite polarity or between an uninsulated live part and grounded dead metal is considered to reduce the spacing by an amount equal to the dimension of the interposed part along the path of measurement.

<sup>a</sup> When measuring an over surface spacing any slot, groove, or similar item 0.013 inch (0.33 mm) wide or less in the contour of the insulating material is to be disregarded. An air space of 0.013 inch or less between a live part and an insulating surface is to be disregarded and the live part considered in contact with insulating material.

No Text on This Page

**Table 21.2**  
**Spacings between uninsulated primary and secondary windings of bobbin-wound transformers**

Potential involved, volts rms	Minimum through air and over surface spacings,	
	inch	(mm)
150 or less	1/16	1.6
Over 150 – 250	3/16	4.8

**Table 21.3**  
**Minimum spacings within a transformer coil**

Potential involved, volts	Through air,		Over surface, <sup>a</sup>	
	inch	(mm)	inch	(mm)
0 – 250	1/16	1.6	1/16	1.6
251 – 600	1/8	3.2	1/8	3.2

NOTE – These spacings do not apply when insulation is provided that complies with 21.4.  
<sup>a</sup> Gaps less than 0.013 inch (0.33 mm) are to be disregarded (bridged) in determining over surface spacings.

21.3 Film-coated wire is considered insulated with regard to adjacent turns of the same coil, but is otherwise considered uninsulated.

21.4 Insulating material used in lieu of spacings shall:

- a) Be rated for the application;
- b) Comply with Table 21.4;
- c) Be resistant to moisture;
- d) Be securely held in place; and
- e) Be of the same strength as electrical grade paper when exposed or otherwise likely to be subjected to mechanical damage.

*Exception No. 1: Insulating material used in lieu of spacings and located between windings not electrically connected together, any windings and the core, any crossover lead and a metallic enclosure, or any crossover lead and the core may be:*

- a) *Electrical grade paper not less than 0.012 inch (0.30 mm) thick;*
- b) *Polymeric coil form not less than 0.025 inch (0.64 mm) thick; or*
- c) *Material equivalent to materials in (a) or (b) with a minimum dielectric breakdown voltage of 2500 volts applied as described in 31.2.1.*

*Exception No. 2: The type and thickness of insulation between the primary crossover lead and the primary winding shall not be specified when the coil complies with:*

- a) The dielectric voltage-withstand test described in 31.1.1 and 31.1.2 with the potential applied between the coil leads and with the inner coil lead cut at the point where it enters the layer or*
- b) The induced potential test described in 31.3.1 – 31.3.3.*

**Table 21.4**  
**Insulation used in lieu of spacings**

Insulating material	Minimum thickness of insulating material,		Minimum portion of specified spacing <sup>a</sup>	Minimum electric breakdown voltage <sup>b</sup>	Circuit potential, volts
	inch	(mm)			
Electrical grade paper	0.028	0.71	–	–	–
Electrical grade paper	0.013	0.33	1/2	–	–
Electrical grade paper	0.010	0.25	–	–	0 – 50
Any	Any		1/2	2500	–
Any	Any		–	5000	–

<sup>a</sup> Spacing required when no insulating material is provided.  
<sup>b</sup> Dielectric voltage-withstand test is to be conducted in accordance with 31.2.1.

21.5 Insulation used in lieu of spacings on a bobbin-wound transformer shall have a continuous bent-up edge against the bobbin end-flanges. The height of the bent-up edge shall be not less than 1/32 inch (0.8 mm).

## PERFORMANCE

### 22 General

22.1 For the tests described in Sections 23 – 37, the number of samples for each test and the order for conducting the tests shall be as specified in Table 22.1. The same sample may be used for more than one test if it remains undamaged from the previous test. If the tests result in damage to the transformer, additional samples may be necessary to complete the test series. Unless otherwise specified, all tests are to be conducted at the supply voltage specified in Table 22.2.

22.2 The frequency of the circuit shall be the rated frequency of the transformer. When the transformer is rated for a range of frequencies, such as 50 – 60 hertz, or has a dual frequency rating, such as 50/60 hertz, tests are to be conducted at 60 hertz except as indicated in 29.2, 34.1, and 35.1.

22.3 The tests described in Sections 27 – 30, 32, 34, and 35 are to be conducted in an ambient air temperature within the range of 21 – 30°C (70 – 86°F).

*Exception: The Rated Output Heating Test, Section 30, with or without standard fuses, but without other forms of overcurrent or overtemperature protectors, may be conducted in an ambient of 10 – 40°C (50 – 104°F).*

**Table 22.1**  
**Sequence of tests and number of samples**

Section	Test	Number of samples
23	Leakage Current	1 <sup>a</sup>
24	Leakage Current After Humidity Conditioning	1 <sup>a</sup>
25	Grounding Continuity	1 <sup>a</sup>
26	Open Circuit Secondary Voltage	3 <sup>b</sup>
27	Output Current and Power	3 <sup>b</sup>
28	Calibration of Overcurrent-Protective Devices	3 <sup>b</sup>
29	Rated Secondary Current	3 <sup>b</sup>
30	Rated Output Heating	1 <sup>b</sup>
31	Dielectric Voltage-Withstand Barrier	1 or more <sup>b</sup> 1 <sup>a</sup>
32	Overload Heating	1 or more <sup>b</sup>
33	Dielectric Voltage-Withstand After Overload Heating	1 or more <sup>b</sup>
34	Overload of Overcurrent- or Overtemperature-Protective Devices	3 <sup>b</sup>
35	Endurance of Automatically-Reset Overtemperature-Protective Devices	3 <sup>b</sup>
36	Strain-Relief	1 <sup>a</sup>
37	Outlet Box Cover Support and Impact Test	3 <sup>a</sup>

<sup>a</sup> A new sample may be used and the test may be conducted in different order.  
<sup>b</sup> The same samples shall be used for these tests in the order indicated; however if a nonreplaceable protective device opens or a coil burnout occurs as specified in Sections 27, 28, and 32, additional samples are to be used for the remaining tests. These additional samples need not be subjected to the preceding tests.

22.4 All exposed dead-metal parts of the transformer are to be connected to ground through a 3-ampere, nondelay type fuse for the following tests (described in Sections 27, 28, 32, 34, and 35, respectively):

- a) Output current and power;
- b) Calibration of overcurrent-protective devices;
- c) Overload heating;
- d) Overload of overcurrent- or overtemperature-protective devices; and
- e) Endurance of automatically-reset, overtemperature-protective devices.

The transformer is to be connected to a circuit having a 20-ampere, branch-circuit protection. The transformer is to be supported on a softwood surface covered by a double layer of tissue paper and is to be draped with a double layer of cheesecloth conforming to the transformer outline. The

cheesecloth is to be untreated cotton cloth 36 inches (914 mm) wide, running 14 – 15 yards per pound mass (approximately 28 – 30 m<sup>2</sup>/kg mass), and having what is known in the trade as a "count of 32 by 28," which means that for any square inch there are 32 threads in one direction and 28 threads in the other direction (for any square centimeter there are 13 threads in one direction and 11 threads in the other direction).

**Table 22.2**  
**Values of test voltages**

Rated primary voltage	Test voltage
120 or less	120 <sup>a,b</sup>
121 – 219	Rated voltage <sup>a</sup>
220 – 240	240
241 – 253	Rated voltage <sup>a</sup>
254 – 277	277
278 – 439	Rated voltage <sup>a</sup>
440 – 480	480
481 – 549	Rated voltage <sup>a</sup>
550 – 600	600

<sup>a</sup> If the rated voltage is expressed as a range, the maximum voltage of the range is to be used.  
<sup>b</sup> If a transformer is rated less than 110 volts and is not intended for use on a 110 – 120 volt circuit, the transformer shall be marked as indicated in 41.17 and the test voltage shall be the rated voltage.

22.5 During the test mentioned in 22.4, a risk of fire or electric shock is considered to exist when any of the following occurs:

- a) Opening of branch circuit protection;
- b) Opening of grounding fuse;
- c) Glowing or flaming of cheesecloth;
- d) Emission of molten material from the transformer enclosure;
- e) Development of any opening in the enclosure that exposes live parts at a potential of more than 42.4 volts peak to any other part or to ground; or
- f) Dielectric breakdown as a result of the Dielectric Voltage-Withstand After Overload Heating Test, Section 33.



## 23 Leakage Current Test

23.1 A cord-connected Class 3 transformer shall be subjected to the test described in 23.2 – 23.8. The results are acceptable when the leakage current does not exceed 0.5 milliamperes.

23.1 revised February 28, 2001

23.2 Leakage current refers to all currents, including capacitively coupled currents, that may be conveyed between exposed conductive surfaces of a transformer and ground or other exposed surfaces of the transformer.

23.3 All exposed conductive surfaces are to be tested for leakage currents. When simultaneously accessible, the leakage currents from these surfaces are to be measured to the grounded supply conductor individually as well as collectively and from one surface to another. Parts are considered to be exposed surfaces unless guarded by an enclosure as defined in 5.3. Surfaces are considered to be simultaneously accessible when they can be readily contacted by one or both hands of a person at the same time. These measurements do not apply to output terminals operating at voltages less than 30 volts (42.4 volts peak). When all accessible surfaces are bonded together and connected to the grounding conductor of the power-supply cord, the leakage current may be measured between the grounding conductor and the grounded supply conductor. When exposed dead metal parts of the transformer are connected to the neutral supply conductor, this connection is to be open during the test.

23.4 When a conductive surface other than metal is used for the enclosure or a part of the enclosure, the leakage current is to be measured using a metal foil with an area of 10 by 20 centimeters in contact with the surface. When the surface is less than 10 by 20 centimeters, the metal foil is to be the same size as the surface. The metal foil is not to remain in place long enough to affect the temperature of the transformer.

23.5 The circuit for the leakage current measurement is to be as illustrated in Figure 23.1. The measurement instrument is defined in 23.5 (a) – (c). The meter that is actually used for a measurement need only indicate the same numerical value for a particular measurement as would the defined instrument. The meter used need not have all the attributes of the defined instrument.

- a) The meter is to have an input impedance of 1500 ohms resistive shunted by a capacitance of 0.15 microfarad.
- b) The meter is to indicate 1.11 times the average of the full-wave rectified composite waveform of voltage across the resistor or current through the resistor.
- c) Over a frequency range of 0 – 100 kilohertz, the measurement circuit is to have a frequency response – ratio of indicated to actual value of current – that is equal to the ratio of the impedance of 1500-ohm resistor shunted by a 0.15-microfarad capacitor to 1500 ohms. At an indication of 0.5 or 0.75 milliamperes, the measurement is not to have an error of more than 5 percent at 60 hertz.

23.6 Unless the meter is being used to measure leakage from one part of a transformer to another, the meter is to be connected between an accessible part and the grounded supply conductor.

**Figure 23.1**  
**Leakage current measurement circuit**

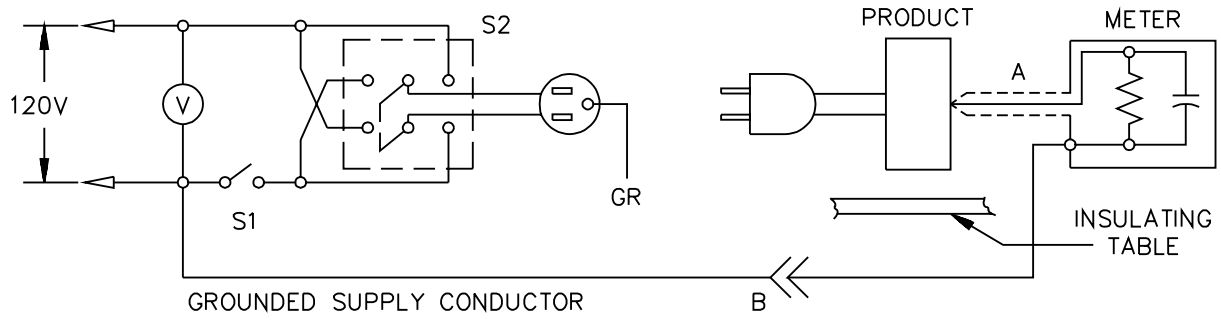

LC100

Unit intended for connection to a 120-volt power supply.

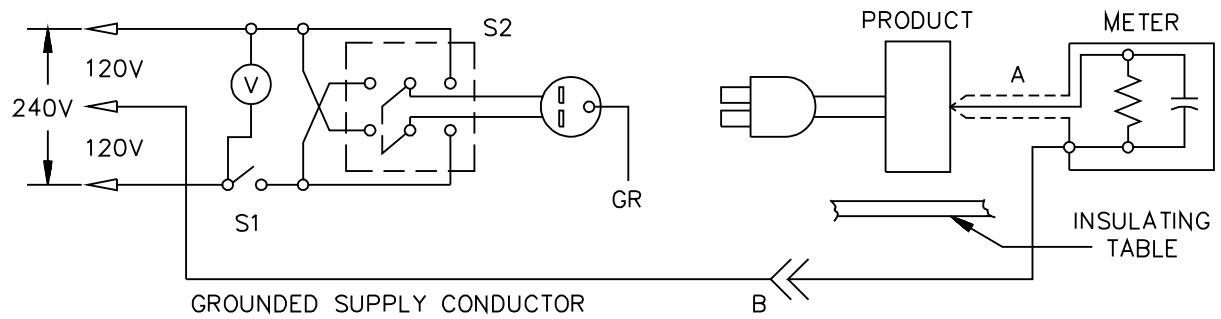

LC200

Unit intended for connection to a 3-wire, grounded neutral power supply, as illustrated above.

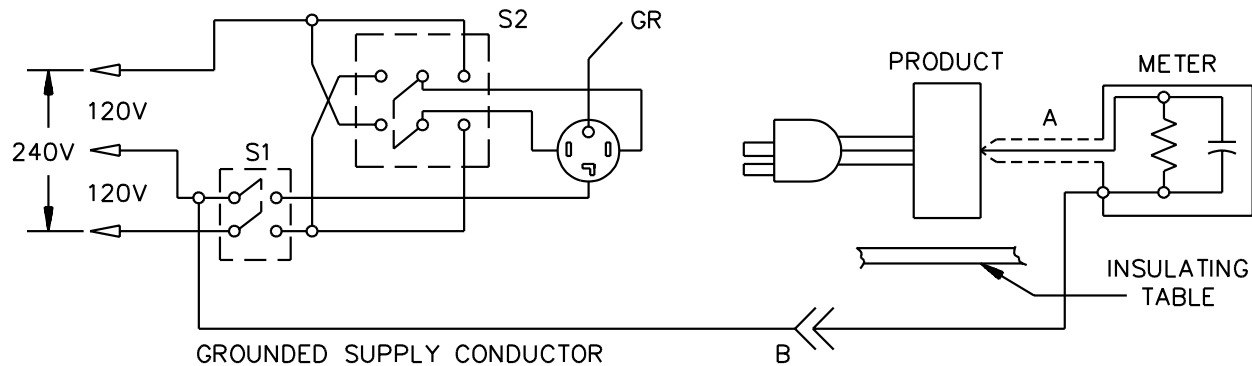

LC300

Unit intended for connection to a 3-wire, grounded neutral power supply, as illustrated above.

NOTE:

- a) Probe with shielded lead.
- b) Separated and used as clip with measuring currents from one part of device to another.

23.7 A sample of the transformer is to be tested for leakage current starting with the as-received condition – the as-received condition is without prior energization except as may occur as part of the production-line testing but with the grounding conductor, if any, open at the attachment plug. The supply voltage is to be adjusted to the test voltage specified in Table 22.2. The test sequence, with reference to the measuring circuit, Figure 23.1, is to be as follows:

- a) With switch S1 open, the transformer is to be without load and connected to the measuring circuit. The leakage current is to be measured using both positions of switch S2 and with any transformer switching devices in all their operating positions.
- b) Switch S1 is then to be closed, energizing the transformer. Within 5 seconds the leakage current is to be measured using both positions of switch S2, and with any transformer switching devices in all their operating positions.
- c) The leakage current is to be monitored until thermal stabilization occurs. Both positions of switch S2 are to be used in making this measurement. Thermal stabilization is considered to be obtained by operation as in the rated output heating test.

23.8 Normally the complete leakage current test program as described in 23.7 is to be conducted without interruption for other tests. With the concurrence of those concerned, the leakage current tests may be interrupted to conduct other nondestructive tests.

## 24 Leakage Current Test Following Humidity Conditioning

24.1 A cord-connected transformer shall comply with the requirements for leakage current in 23.1, following exposure for 48 hours to air having a relative humidity of  $88 \pm 2$  percent at a temperature of  $32 \pm 2^\circ\text{C}$  ( $90 \pm 4^\circ\text{F}$ ).

24.2 To determine whether a product complies with the requirement in 24.1, the transformer sample is to be heated to a temperature just above  $34^\circ\text{C}$  ( $93^\circ\text{F}$ ) to reduce the likelihood of condensation of moisture during conditioning. The heated sample is to be placed in the humidity chamber and is to remain for 48 hours under the conditions specified in 24.1. Following the conditioning, the sample is to be tested unenergized as described in 23.7(a). The sample is then to be energized and tested as described in 23.7 (b) and (c). The test is to be discontinued when the leakage current stabilizes or decreases.

## 25 Grounding Continuity Test

25.1 To determine if a Class 3 transformer provided with a flexible cord complies with 15.12, a current of 25 amperes, derived from a 60 hertz source at a no load voltage of not more than 12 volts, is passed between the grounding blade of the attachment plug and the metal part in question for 1 minute. The results are acceptable if the voltage between the grounding blade and the part does not exceed  $1.0F$  volts, where F is the length of the cord in feet ( $3.28M$  volts, where M is the length of the cord in meters).

25.1 revised February 28, 2001

## 26 Open-Circuit Secondary Voltage Test

26.1 The open-circuit voltage between any two of the secondary terminals of a Class 2 transformer shall be not more than 15 volts, or 21.2 volts peak, with or without any combination of interconnected secondary terminals, when the primary is energized in accordance with 22.1 and 22.2.

*Exception No. 1: The open-circuit voltage between secondary terminals of a two-secondary winding transformer may exceed 21.2 volts peak when secondary terminals are interconnected, if the following conditions are met:*

- a) The open-circuit voltage between any two terminals is not more than 21.2 volts peak when no connections are made between secondary terminals and*
- b) The transformer is marked in accordance with 41.7.*

*Exception No. 2: The open-circuit voltage between any two of the secondary terminals with or without any combination of interconnected secondary terminals, may be more than 21.2 volts peak, but not more than 42.4 volts peak, if the transformer is marked in accordance with 41.13.*

*Exception No. 3: The open-circuit voltage between secondary terminals of a two-secondary winding transformer may exceed 21.2 volts peak when secondary terminals are interconnected, if the following conditions are met:*

- a) The open-circuit voltage between any two terminals is not more than 42.4 volts peak when no connections are made between secondary terminals and*
- b) The transformer is marked in accordance with 41.7 and 41.13.*

26.2 The open-circuit voltage between any two of the secondary terminals of a Class 3 transformer shall not be more than 100 volts, with or without any combination of interconnected secondary terminals, when the primary is energized in accordance with 22.1 and 22.2.

*Exception: If the secondary current does not exceed 1 ampere in accordance with 27.2.1, the secondary voltage of a not inherently limited transformer may be not more than 150 volts.*

26.3 Voltage measurements are to be made using a voltmeter having an internal impedance of not less than 3,000 ohms per volt.

No Text on This Page

## 27 Output Current and Power Test

### 27.1 Maximum output current of inherently limited transformers

27.1.1 The output current of a Class 2 or 3 transformer intended to be inherently power limited shall be tested as described in 27.1.2 – 27.1.7 and the flow chart in Figure 27.1. Unless the transformer is marked in accordance with 41.7, multiple secondary windings, if any, shall be interconnected to produce maximum current.

27.1.1 revised May 24, 1999

**Table 27.1**  
**Maximum output current – Part I**

\*Tables 27.1 and 27.2 revised and relocated as Figure 27.1 May 24, 1999\*

27.1.2 Under the conditions described in Performance, General, Section 22, and 27.1.1, a resistance load is to be determined that produces the largest initial value of current (including short circuit). The secondary is to be loaded with this value of resistance, and the transformer is to be energized while at room temperature. The results comply when the current does not exceed the values specified in Table 27.3 for inherently limited power sources and there is no evidence of a risk of fire or electric shock as described in 22.4 and 22.5. The current is to be measured after the applicable time of operation:

- a) When a separate current-limiting impedance is provided [such as a resistor or a positive temperature coefficient device (PTC)], the current is to be measured after 5 seconds of operation.
- b) When no separate current-limiting impedance is provided, the current is to be measured after 1 minute of operation.

27.1.3 When the impedance of the short circuit measuring circuit in the secondary is to be not more than 0.03 ohm. When the secondary of a transformer is provided with leads or a flexible cord, only 1 foot (305 mm) of each lead or the cord is to be included in the short circuit.

27.1.4 When the current is interrupted by a resettable or replaceable protective device during the test, the test is to be repeated with the protective device shorted.

**Table 27.2**  
**Maximum output current – Part II**

\*Tables 27.1 and 27.2 revised and relocated as Figure 27.1 May 24, 1999\*



**Figure 27.1**  
**Test flow chart**

\*Tables 27.1 and 27.2 revised and relocated as Figure 27.1 May 24, 1999\*

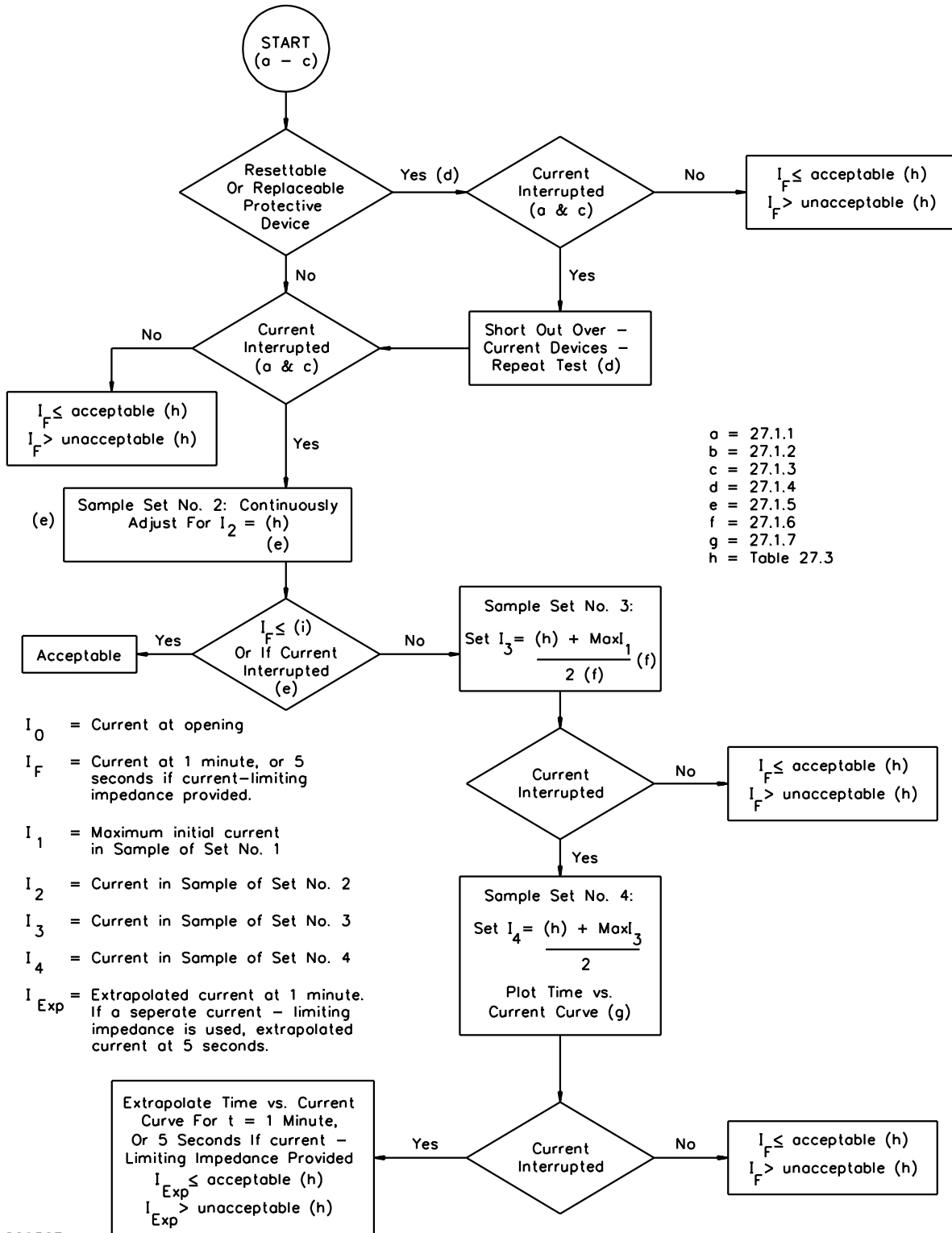

No Text on This Page

27.1.5 When the current is interrupted by a nonresettable, nonreplaceable protector or by coil burnout, other samples are to be tested by attempting to adjust continuously the resistance load to hold the current for the applicable time limit specified in 27.1.2 just greater than the value specified in Table 27.3. The results comply when the value specified in Table 27.3 cannot be maintained for the applicable time limit or when the current is interrupted.

27.1.6 When the current described in 27.1.5 exceeds the value specified in Table 27.3 after operating for the applicable time limit specified in 27.1.2, another sample is to be tested. The resistance load is to be adjusted to provide an initial current midway between the maximum initial obtainable value and the value specified in Table 27.3. The value of resistance is not to be further adjusted during the test. After operating for the applicable time limit, the results comply when the output current does not exceed the values specified in Table 27.3.

27.1.7 When the test described in 27.1.6 again results in current interruption, another sample is to be tested as described in 27.1.6. The initial current is to be adjusted to a point midway between the initial current recorded during the test in 27.1.6 and the value specified in Figure 27.1. During this test, values of current versus time are to be recorded. If the current is again interrupted during operation before the applicable time limit specified in 27.1.2, the recorded curve of current versus time is to be extended to the applicable time limit by a french curve. The results comply when this extrapolation value of current, after the applicable time limit, does not exceed the values specified in Table 27.3.

27.1.7 revised May 24, 1999

## **27.2 Maximum current of not inherently limited transformers**

27.2.1 When the transformer is not an inherently limited transformer, it shall be tested as described in 27.1.1 – 27.1.7. Protective devices are to be shorted out during this test. The results comply when the maximum current does not exceed the values shown in Table 27.3 for not inherently limited transformers. For the purpose of this test, the transformers need not comply with 22.5 as referenced in 27.1.2.

**Table 27.3**  
**Current and power limitations**

Circuit	Inherently limited transformer (overcurrent protection not required)			Not inherently limited transformer (overcurrent protection required)				
	Class 2		Class 3	Class 2			Class 3	
Circuit voltage (volts)	0 – 20 <sup>b</sup>	Over 20 but no more than 30 <sup>a</sup>	Over 30 but no more than 100	0 – 15 <sup>a</sup>	Over 15 but no more than 20 <sup>a</sup>	Over 20 but no more than 30 <sup>a</sup>	Over 30 but no more than 100	Over 100 but no more than 150
Power limitation (volt-amperes) <sup>b</sup>	–	–	–	350	250	250	250	–
Current limitation (amperes) <sup>c</sup>	8	8	150/V	1000/V	1000/V	1000/V	1000/V	1
Maximum overcurrent protection (amperes)	–	–	–	5	5	100/V	100/V	1
Transformer maximum nameplate rating:								
Power (volt-amperes)	5×V	100	100	5×V	5×V	100	100	100
Current (amperes)	5	100/V	100/V	5	5	100/V	100/V	100/V

**NOTES**

1 In all cases the applied primary voltage shall be as indicated in 22.2 and Table 22.2.

2 V is the maximum output voltage, regardless of load, with rated input applied.

<sup>a</sup> Voltage ranges shown are for sinusoidal AC in indoor locations or where wet contact is not likely to occur. For nonsinusoidal AC, V shall be no greater than 42.4 volts peak. Where wet contact (immersion not included) is likely to occur, Class 3 wiring methods shall be used or V shall be no greater than 15 volts for sinusoidal AC, and 21.2 volts peak for nonsinusoidal AC.

<sup>b</sup> Maximum volt-ampere output regardless of load, and overcurrent protection (if used) bypassed. Current-limiting impedances (if used) not bypassed.

<sup>c</sup> Maximum output after 1 minute of operation under any noncapacitive load, including short circuit, and with overcurrent protection (if provided) bypassed. For a current-limiting impedance, maximum output after 5 seconds of operation under any noncapacitive load, including short-circuit, and with overcurrent protection (if provided) bypassed. Current-limiting impedances (if used) not bypassed.

### 27.3 Maximum power of not inherently limited transformers

27.3.1 The maximum obtainable output power is not to exceed the value shown in Table 27.3. Protective devices are to be shorted out during this test. Unless the transformer is marked in accordance with 41.7, multiple secondary windings, if any, are to be interconnected to produce maximum output power. For the purpose of this test, the transformer need not comply with 22.5 as referenced in 27.1.2. The maximum output power is to be determined by the steps described in 27.3.1 (a) – (g). Different samples are to be used for each condition.

- a) The full load secondary voltage ( $V_{FL}$ ) is to be measured at rated secondary current ( $I_{FL}$ ).

b) Using the value of the open circuit secondary voltage ( $V_{OC}$ ) determined as described in the Open Circuit Secondary Voltage Test, Section 26, the internal resistance ( $R_I$ ) of the transformer is to be calculated using the formula:

$$R_I = \frac{V_{OC} - V_{FL}}{I_{FL}}$$

c) The load resistance ( $R_L$ ) required in 27.3.1 (d), (f) and (g) is to be calculated using the formula:

$$R_L = R_I \frac{\%}{1.0 - \%}$$

in which:

*% is the percent of open circuit secondary voltage (for example, for the value 50, % would be equal to the value 0.5).*

d) Starting with the transformer at room temperature, the transformer is to be loaded with a resistance load ( $R_L$ ), calculated as described in 27.3.1(c), with the percent of open circuit secondary voltage (%) equal to 0.65. The ampere rating of the resistance load ( $R_L$ ) shall be not less than the maximum secondary output current ( $I_O$ ). At the end of 2 minutes of operation, the secondary voltage ( $V_O$ ) and secondary output current ( $I_O$ ) are to be measured. Once the transformer is energized, there shall be no adjustment of the resistance load ( $R_L$ ).

e) The maximum output power ( $VA_O$ ) is to be calculated using the formula:

$$VA_O = V_O \times I_O$$

f) If the output power ( $VA_O$ ) calculated in 27.3.1(e) exceeds the value in Figure 27.1, the result does not comply. If the output power ( $VA_O$ ) calculated in 27.3.1(e) is not more than 80 percent of the value in Table 27.3, the result complies. If the output power ( $VA_O$ ) calculated in 27.3.1(e) is within 20 percent of the value in Table 27.3, then additional secondary voltage ( $V_O$ ) and current ( $I_O$ ) measurements are to be made and the maximum output power ( $VA_O$ ) is to be calculated with the percent of open circuit secondary voltage (%) equal to 0.6 and 0.7. The results do not comply if the calculated output power ( $VA_O$ ) exceeds the value in Table 27.3.

g) If the maximum output power ( $VA_O$ ) calculated at either the 0.6 or 0.7 level in 27.3.1(f) is greater than that calculated in 27.3.1(e), additional measurements are to be made. The resistance load ( $R_L$ ) is to be set to the value calculated with the percent of open circuit secondary voltage (%) in 27.3.1(f) which resulted in a calculated maximum output power greater than that calculated in 27.3.1(e). Successive 0.05 increments are to be used to calculate  $R_L$  and measurements are to be taken until the calculated output power ( $VA_O$ ) starts to decline. The results comply if the maximum calculated output power ( $VA_O$ ) does not exceed the appropriate value in Table 27.3.

## 28 Calibration Test of Overcurrent-Protective Devices

28.1 A device used for overcurrent protection provided as a part of a not inherently limiting Class 2 or Class 3 transformer shall operate to open the circuit in not more than the time indicated in Table 28.1 when the transformer is delivering the specified secondary current. The protective device may be located in either the primary or secondary circuit. The results comply when there is no emission of flame or molten metal from the transformer enclosure and no other evidence of a risk of fire or electric shock as described in 22.4 and 22.5.

*Exception: This test need not be conducted if a suitably rated fuse investigated in accordance with the requirements of the Standard for Low-Voltage Fuses, UL 248, is provided in the output circuit (see Table 27.3).*

28.1 revised February 28, 2001

**Table 28.1**  
**Maximum acceptable time to open**

Open circuit secondary potential, volts	Secondary test current, amperes	Maximum time for overcurrent-protective device to open, minutes
<b>Class 2</b>		
20 or less	10	2
20 or less	6.75	60 <sup>a</sup>
Over 20 to 30	$200/V_{\max}$	2
Over 20 to 30	$135/V_{\max}$	60 <sup>a</sup>
<b>Class 3</b>		
Over 30 to 100	$200/V_{\max}$	2
Over 30 to 100	$135/V_{\max}$	60 <sup>a</sup>
Over 100 to 150	2	2
Over 100 to 150	1.35	60 <sup>a</sup>
<sup>a</sup> After 15 minutes of operation, the current is to be readjusted to return the power to the value shown.		

28.2 To determine if an overcurrent-protective device complies with the requirement in 28.1, the transformer is to deliver the test current to a resistance load, with the primary connected to a circuit as described in Performance, General, Section 22.

28.3 If there is more than one secondary or if the secondary has accessible taps, tests shall be conducted to determine that for any winding or partial winding, the protective device will open within the time-current value shown in Table 28.1.

28.4 Each resistive load condition shall be started with the transformer at ambient air temperature as specified in 22.3.

28.4 revised February 28, 2001

## 29 Rated Secondary Current Test

29.1 A transformer marked with a secondary current rating shall be capable of delivering its rated full load secondary current continuously. When the transformer has its output rated in volt-amperes or watts, the rated output current is to be determined by dividing the rated output voltage into the rated output volt-amperes or watts.

29.2 To determine whether a transformer complies with the requirement in 29.1, a transformer is to be tested with a variable resistance and ammeter connected to the secondary, and the primary connected to a circuit in accordance with 22.1 and 22.3. When the transformer is rated for a range of frequencies (such as 50 – 60 hertz) or has a dual frequency rating (such a 50/60 hertz), the test is to be

No Text on This Page



conducted with the supply circuit at the lowest frequency. The resistor is to be adjusted until the rated full-load secondary current is drawn. When the transformer has an overtemperature or overcurrent-protective device, the transformer is to be mounted so that the device is at the top. In all other cases the transformer is to be mounted so that primary terminals or line end of the leads are on top. After 15 minutes of operation, the load is to be readjusted, if necessary, to return the current to the full-load value. The circuit is to be kept energized for 1 hour without further adjustment. At the end of the 1-hour period, the output current shall not be less than 90 percent of the rated value, and the overtemperature or overcurrent-protective device shall not function. The test is to be performed at the ambient temperature specified in 22.3.

29.3 Regarding 29.2, when a transformer has two secondary windings, both windings are to be operated simultaneously with each secondary winding independently loaded.

### 30 Rated Output Heating Test

30.1 The test described in the Rated Secondary Current Test, Section 29, is to be continued without further adjustment until temperatures become constant. Protective devices are not to be shorted out during the test. The temperature rise on various materials and parts shall not exceed the limits specified in Table 30.1, and protective devices shall not operate during the test.

30.2 Regarding note c of Table 30.1, a material's thermal conductivity can be obtained by comparing it with the known thermal conductivity of another material. A sample of the material with the unknown value of thermal conductivity is to be the same size as used in the transformer. It is to be placed in direct contact along one full side with a heated metal plate. A sample of the same size material with a known value of thermal conductivity is to be placed directly on top of the unknown material, along one full side. The change in temperature through each material is to be measured at points along the same vertical axis, and the coefficient of thermal conductivity of the unknown material may be derived from the following equation:

$$\frac{T \text{ of known material}}{T \text{ of unknown material}} = \frac{\text{coefficient of unknown material}}{\text{coefficient of known material}}$$

30.3 Other than those cases where it is specifically stated that temperature determinations are to be made by the resistance method, temperatures are to be measured by means of thermocouples. A thermocouple measured temperature is to be considered constant if three successive readings, taken at intervals of 10 percent of the previously elapsed duration of the test, but at not less than 5-minute intervals, indicate no change. The junction of the thermocouple is to be secured in contact with the point on the surface at which the temperature is to be measured. The thermocouple is to consist of wires not larger than 24 AWG (0.21 mm<sup>2</sup>).

30.3 revised February 10, 2004

30.4 Coil and winding temperatures are to be determined by the resistance method.

30.5 When thermocouples are used to determine temperatures involving the heating of electrical devices, it is standard practice to use thermocouples consisting of 30 AWG (0.05 mm<sup>2</sup>) iron and constantan wires and a potentiometer-type indicating instrument. Such equipment is to be used whenever referee temperature measurements are necessary. The thermocouple wire is to conform with the requirements for special thermocouples specified in the Initial Calibration Tolerances for Thermocouples table in Temperature Measurement Thermocouples, ANSI/ISA MC96.1.

30.5 revised February 10, 2004

**Table 30.1**  
**Maximum acceptable temperature rises**

Table 30.1 revised May 24, 1999

Material	°C	(°F)
1. Rubber or thermoplastic insulated conductors <sup>a</sup>	35	63
2. Primary circuit field wiring <sup>b</sup>	35	63
3. Fuses other than Class CC, G, J, or T, and fuses other than those with glass or ceramic bodies	65	117
4. Class CC, G, J, or T fuses and those fuses with glass or ceramic bodies	85	153
5. Fiber used as electric insulation	65	117
6. Varnish-cloth insulation	60	108
7. Phenolic composition <sup>a</sup>	125	225
8. Wood or similar material	65	117
9. Class 105 transformer insulation system:		
Resistance method	75	135
Thermocouple method	65	117
10. Class 130 transformer insulation system:		
Resistance method	95	171
Thermocouple method	85	153
11. Class 155 transformer insulation system:		
Resistance method	115	207
Thermocouple method	110	198
12. Class 180 transformer insulation system:		
Resistance method	135	243
Thermocouple method	125	225
13. Surface temperature, permanently-connected transformer	60	108
14. Surface temperature, cord-connected: <sup>c</sup>		
Metal	30	54
Nonmetallic	55	99
15. Polymeric material <sup>d</sup>	40°C (104°F) less than its temperature rating	

Table 30.1 Continued on Next Page

Table 30.1 Continued

Material	°C	(°F)
<p><sup>a</sup> The limitations on phenolic composition and on rubber and thermoplastic insulation do not apply to compounds that have been investigated and found to be acceptable for use at a higher temperature; however, the maximum acceptable temperature rise is not to equal or exceed a value that is the acceptable temperature limit for the material in question.</p> <p><sup>b</sup> The maximum acceptable temperature rise at primary circuit field wiring may be 65°C if the transformer is marked in accordance with 41.14 and Table 41.1.</p> <p><sup>c</sup> A material having a coefficient of thermal conductivity greater than 2.419 Btu-ft/hour-ft<sup>2</sup>·°F (4.18 W/M·K) is considered to be metal.</p> <p><sup>d</sup> Material relied upon for enclosure, barriers, or direct or indirect support of live parts other than coils. Polymeric material used in a Class 105 coil insulation system shall have an electrical relative thermal index not less than 105°C (221°F).</p>		

30.6 The temperature rise of a copper or aluminum winding is to be calculated by the following formula (windings are to be at room temperature at the start of the test):

$$\Delta t = \frac{R}{r} (k + t_1) - (k + t_2)$$

*in which:*

$\Delta t$  is the temperature rise;

$R$  is the resistance of the coil at the end of the test;

$r$  is the resistance of the coil at the beginning of the test;

$k$  is 234.5 for copper and 225.0 for aluminum;

$t_1$  is the room temperature at the beginning of the test, in °C; and

$t_2$  is the room temperature at the end of the test, in °C.

30.7 Since it is generally necessary to de-energize the winding before measuring  $R$ , the value of  $R$  at shutdown may be determined by taking several resistance measurements at short intervals, beginning as quickly as possible after shutdown. A curve of the resistance values against time may be plotted and extrapolated to give the value of  $R$  at shutdown. A similar result may be achieved by using the least square statistical method with a computer or programmable calculator. Instrumentation by which  $R$  can be measured while the coil is energized may be used.

## 31 Dielectric Voltage-Withstand Test

### 31.1 General

31.1.1 A transformer shall be subjected for 1 minute to the application of a 60-hertz, essentially sinusoidal potential with the unit at the maximum operating temperature reached in the Rated Output Heating Test, Section 30. The results comply when there is no dielectric breakdown. The applied potential is to be:

- a) 1000 volts plus twice the primary test voltage as specified in Table 22.2 between the primary circuit and accessible, dead-metal parts.
- b) For a Class 2 transformer, 2500 volts between the primary and secondary circuits. For a Class 3 transformer, the voltage described in 31.1.1(a) between the primary and secondary circuits.
- c) 1000 volts plus two times the sum of the secondary voltages between the secondary windings unless considered as a single winding as described in Exception No. 1 to 17.1.
- d) 500 volts between a secondary circuit operating at 30 volts (42.4 volts peak) or less and accessible, dead-metal parts; 1000 volts plus twice the maximum rated secondary circuit voltage between a secondary circuit voltage between a secondary circuit operating at more than 30 volts (42.4 volts peak) and accessible, dead-metal parts.

31.1.2 To determine if a transformer complies with the requirements in 32.1, it is to be tested by means of a transformer with a capacity of 500 volt-amperes or larger, having an output voltage that is essentially sinusoidal and can be varied. The applied potential is to be increased from zero until the required test level is reached and is to be held at that level for 1 minute. The applied potential is to be increased at a uniform rate as rapid as is consistent with its correct value indicated by the voltmeter.

*Exception: A 500 volt-ampere or larger capacity transformer is not required when the transformer is provided with a voltmeter to measure directly the applied output potential.*

31.1.3 Dielectric breakdown, not leakage current, shall be the criterion that determines compliance. Leakage current is the normal flow of current due to imperfect insulating materials and can vary with the applied voltage. Dielectric breakdown typically occurs when there is an abrupt decrease or retarded advance of the voltmeter reading.

### 31.2 Insulating barriers

31.2.1 With respect to 21.4, the insulating material is to be placed between opposing metal electrodes. The electrodes are to be cylindrical brass or stainless steel rods 1/4 inch (6.4 mm) in diameter with edges rounded to a 1/32 inch (0.8 mm) radius. The upper moveable electrode is to weigh  $50 \pm 2$  grams to exert sufficient pressure on the specimen and provide good electrical contact. The test potential is to be increased to the test value, and the maximum test potential is to be maintained for 1 second. There shall not be dielectric breakdown.

### 31.3 Induced potential

31.3.1 A transformer tested in accordance with 17.6 or with Exception No. 2 to 21.4 shall be subjected to the application of an alternating potential between the terminals of one winding with the ends of all other windings of the transformer open. The potential shall be twice the rated voltage of the winding under test. The frequency of the applied potential is to be minimum twice the rated frequency of the transformer and is to be applied for 7200 cycles. There shall not be dielectric breakdown.

31.3.2 Regarding 31.3.1, a transformer is to be in a heated condition resulting from the Rated Output Heating Test, Section 30. Alternatively, the transformer may be conditioned in an oven set at the temperature recorded during the heating test before the induced potential test is conducted.

31.3.3 The test voltage specified in 31.3.1 is to be started at one-quarter or less of the full value and increased to full value in not more than 15 seconds. After being held for the time specified, the voltage is to be reduced slowly to one-quarter of the maximum value or less within 5 seconds, and the circuit is to be opened.

## 32 Overload Heating Test

### 32.1 General

32.1.1 A transformer shall be subjected to the overload tests described in 32.2.1 – 32.2.8, as specified in Performance, General, Section 22. A protective device that is relied upon to open the circuit as a result of the tests is to be one that has been investigated for this purpose.

### 32.2 Procedure

32.2.1 One sample of a transformer is to be operated under conditions of Table 32.1 as described in 32.2.2 – 32.2.8 and Figure 32.1). One minute after completion of the test, the transformer is to be subjected to the Dielectric Voltage-Withstand After Overload Heating Test, Section 33.

32.2.1 revised May 24, 1999

**Table 32.1**  
**Test loading conditions**

Condition	Secondary winding load
A	Load used for final sample in tests described in 27.1.1 – 27.2.1
B	Rectifier to cause half wave rectified short circuit
(For conditions C – I) rated current plus indicated percent of difference between condition A and rated current:	
C	75
D	50
E	25
F	20
G	15
H	10
I	5

**Table 32.2**  
**Overload heating test – Part I**

\*Tables 32.2 and 32.3 revised and relocated as Figure 32.1 May 24, 1999\*

**Table 32.3**  
**Overload heating test – Part II**

\*Tables 32.2 and 32.3 revised and relocated as Figure 32.1 May 24, 1999\*

32.2.2 The test is to be terminated when the transformer operates the full 7 hours as described in 32.2.3 without a winding or protective device opening and complies with the following items:

- a) The temperature rise of the coil, determined by the resistance method described in 30.6 and 30.7, does not exceed the temperature rise specified in Table 32.4 for the appropriate class of insulation.

*Exception: The temperature rise may exceed the value specified in Table 32.4 if the test is continued on three samples for 15 days as described in 32.2.4.*

- b) There is no evidence of risk of fire or electric shock as described in 22.5.

32.2.3 Condition A of Table 32.1 is to be used as the test condition unless the test is then interrupted by a protector or burnout before 7 hours has elapsed. The next condition in the table is then to be used. This is to continue as shown in Figure 32.1 until a transformer operates the full 7 hours or, if the temperature rise at the end of 7 hours exceeds the values given in 32.2.2(a), until three samples of the transformer operate for 15 days as described in 32.2.4. Test conditions A – I may be run sequentially or simultaneously.

32.2.3 revised May 24, 1999

**Figure 32.1**  
**Overload heating test flow chart**

\*Tables 32.2 and 32.3 revised and relocated as Figure 32.1 May 24, 1999\*

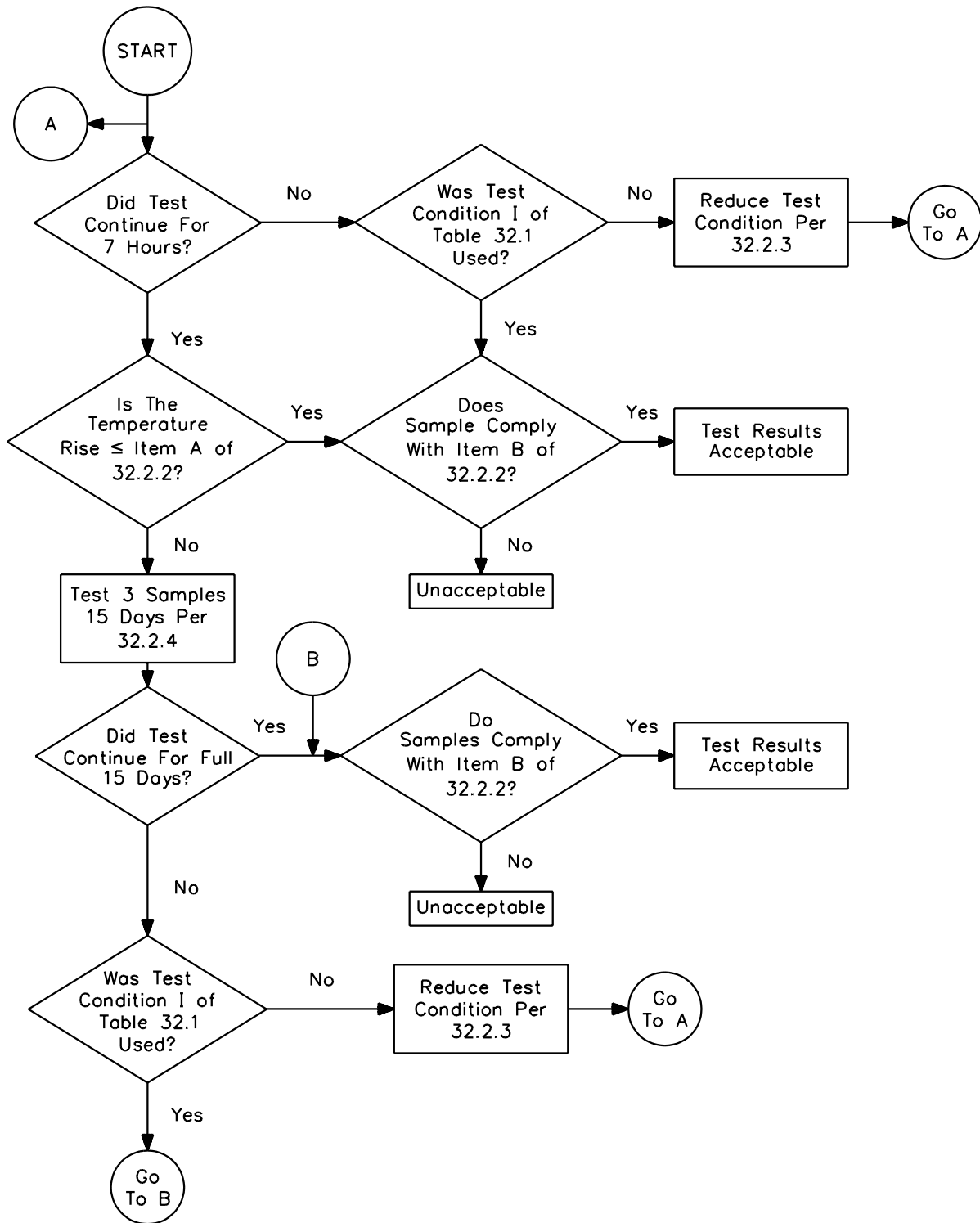

S2897D

No Text on This Page



**Table 32.4**  
**Maximum acceptable coil temperature rise for insulation systems**

Insulation system class	Temperature rise	
	°C	(°F)
105	105	189
130 <sup>a</sup>	135	243
155 <sup>a</sup>	160	288
180 <sup>a</sup>	185	333

<sup>a</sup> Insulation shall comply with the requirements in 17.3.

32.2.4 In accordance with the exception of 32.2.2(a), three samples of the transformer are to be tested for 15 days under the condition specified in Table 32.1 that caused the temperature rise values in 32.2.2(a) to be exceeded. At the end of 15 days, the transformer shall comply with 32.2.2(b). If the 15-day test is interrupted and the transformer complies with 32.2.2(b), the next condition is to be used and the test is to be continued as described in 32.2.3. If this 15-day test is interrupted, and the transformer does not comply with 32.2.2(b), the result does not comply.

32.2.5 For the purpose of these requirements, each secondary winding tap is considered the equivalent of a secondary winding.

32.2.6 When a transformer is equipped with more than one secondary winding, each of the secondary windings is to be loaded for each condition specified in Table 32.1 with the other windings loaded to rated current.

32.2.7 All secondary windings are to be loaded to rated current before the abnormal condition is introduced. The loads, other than the one connected to the winding to be overloaded, are not to be readjusted thereafter.

32.2.8 For the loading conditions, a variable resistor is to be connected across the secondary winding. The tests described in conditions A – I of Table 32.1 are to be continued for 7 hours unless a winding of the transformer or a protective device opens in a shorter time. When conducting the tests described in conditions C – I of Table 32.1, the variable resistance load is to be adjusted to the required value as quickly as possible and readjusted, if necessary, 1 minute after application of voltage to the primary winding.

### **33 Dielectric Voltage-Withstand After Overload Heating Test**

33.1 One minute after completion of the overload heating test, a transformer is to be subjected to the Dielectric Voltage-Withstand Test, Section 31.

*Exception: The voltage between primary and secondary need not exceed 1000 volts plus twice the primary test voltages covered in 22.1 and Table 22.2.*

### 34 Overload Test of Overcurrent- or Overtemperature-Protective Devices

34.1 A protective device (other than a fuse, thermal cutoff, or an automatically-resettable device as covered in the Endurance Test of Automatically-Reset, Overtemperature-Protective Devices, Section 35) provided as a part of a transformer shall be capable of making and breaking the circuit for a total of 50 cycles of operation with the transformer loaded in accordance with 27.1.1, 27.1.2, and 27.2.1. The transformer is to be connected to a source of supply as described in Performance, General, Section 22. If the transformer is rated for a range of frequencies (such as 50 – 60 hertz) or has a dual frequency rating (such as 50/60 hertz) the test is to be conducted at the lowest frequency. The results comply when there is no emission of flame or molten material from the transformer enclosure, or other evidence of a risk of fire or electric shock, as described in 22.4 and 22.5, and the overcurrent-protective device is operable at the end of the test.

34.2 In the test of a manually-resettable protective device, the device is to be reset as soon as possible after opening; however, if the device cannot be reset within 1 hour after opening in any cycle, the test is to be stopped and the device is to be considered inoperable.

### 35 Endurance Test of Automatically-Reset, Overtemperature-Protective Devices

35.1 A transformer provided with an automatically-reset, overtemperature-protective device shall be subjected to an endurance test. The secondary is to be loaded as described in the Output Current and Power Test, Section 27, to produce the maximum possible current through the automatic-reset device. The transformer is to be connected to a source of supply as described in Performance, General, Section 22. When the transformer is rated for a range of frequencies (such as 50 – 60 hertz) or has a dual frequency rating (such as a 50/60 hertz) the test is to be conducted at the lowest frequency. The transformer is to operate for 15 days. The results comply when:

- a) There is no emission of flame or molten material from the transformer enclosure;
- b) There is no other evidence of a risk of fire or electric shock as described in 22.4 and 22.5; and
- c) The protective device remains operable.

*Exception No. 1: When the current results in interruption of an overcurrent-protective device, a new transformer is to be tested starting with the load current that caused a current of 110 percent of the overcurrent device rating to flow through the overcurrent device. If the overcurrent device opens the circuit before 15 days, a new transformer is to be tested. The load current is to be decreased in increments of 2 percent of the overcurrent device rating until a current is reached at which the overcurrent device does not open within 15 days.*

*Exception No. 2: The test does not have to be conducted when the protective device has been previously tested for 6000 cycles of operation at the maximum measured voltage and maximum available current of the winding circuit to which it is connected as determined in the Output Current and Power Test, Section 27.*

## **36 Strain-Relief Test**

### **36.1 Flexible cord**

36.1.1 The strain-relief means provided on a flexible supply cord of a Class 3 transformer shall be subjected to a direct pull of 35 pounds (156 N) applied to the cord for 1 minute with the connections within the transformer disconnected. The force is to be applied so that the strain-relief means will be stressed from any angle that the transformer construction permits. At the point of disconnection of the conductors, there shall be no movement of the cord to indicate that stress on the connections would have resulted.

36.1.1 revised February 28, 2001

36.1.2 The strain-relief means provided for the output cord on a Class 3 transformer shall be subjected to a direct pull of 20 pounds (89 N) for 1 minute. With the output cord connected internally, movement of the cord shall not result in a reduction of spacings to primary or dead metal parts, damage to the transformer or enclosure, or interruption of the output circuit wiring.

36.1.2 revised February 28, 2001

### **36.2 Leads**

36.2.1 The strain-relief means on a lead intended for connection to field wiring shall be subjected to a force equal to the weight of the transformer but not less than 3 pounds (13.4 N) nor more than 10 pounds (45 N). The force is to be applied to the lead for 1 minute in any direction allowed by the construction. There shall be no indication that stress on the connections inside the transformer would have resulted.

## **37 Outlet Box Cover Support and Impact Tests**

### **37.1 General**

37.1.1 When a transformer is provided with a nonmetallic cover intended to cover an outlet box as described in 7.4, the cover shall be subjected to the tests described in 37.2.1 and 37.3.1. There shall be no cracking or crazing of the cover and, at the conclusion of the test, the cover shall withstand a potential of  $2V + 1000$  volts (applied as described in 31.1.1) without dielectric breakdown.  $V$  is the test voltage specified in Table 22.2.

### **37.2 Support**

37.2.1 One sample of the transformer and cover is to be mounted on an outlet box and subjected to application of a weight three times the weight of the transformer using both configurations shown in Figure 37.1.

### 37.3 Impact

37.3.1 Three samples of the transformer and cover shall be subjected to a single impact of 5 foot-pounds (6.8 J) with the transformer and cover mounted on an outlet box. The impact is to be produced as shown in Figure 37.2 by:

- a) Dropping a steel sphere 2 inches (50.8 mm) in diameter and weighing 1.18 pounds (0.535 kg) from a height of 51 inches (1.3 m) or
- b) Suspending the steel sphere from a cord and swinging it as a pendulum, dropping through a vertical distance of 51 inches.

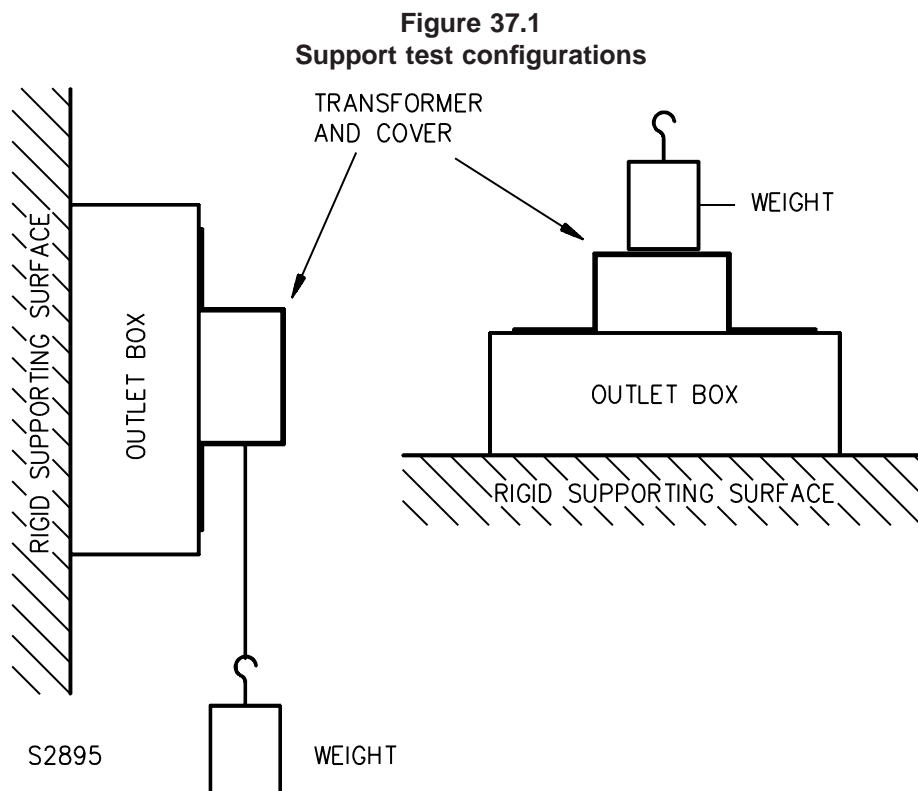

**Figure 37.2**  
**Ball impact test**

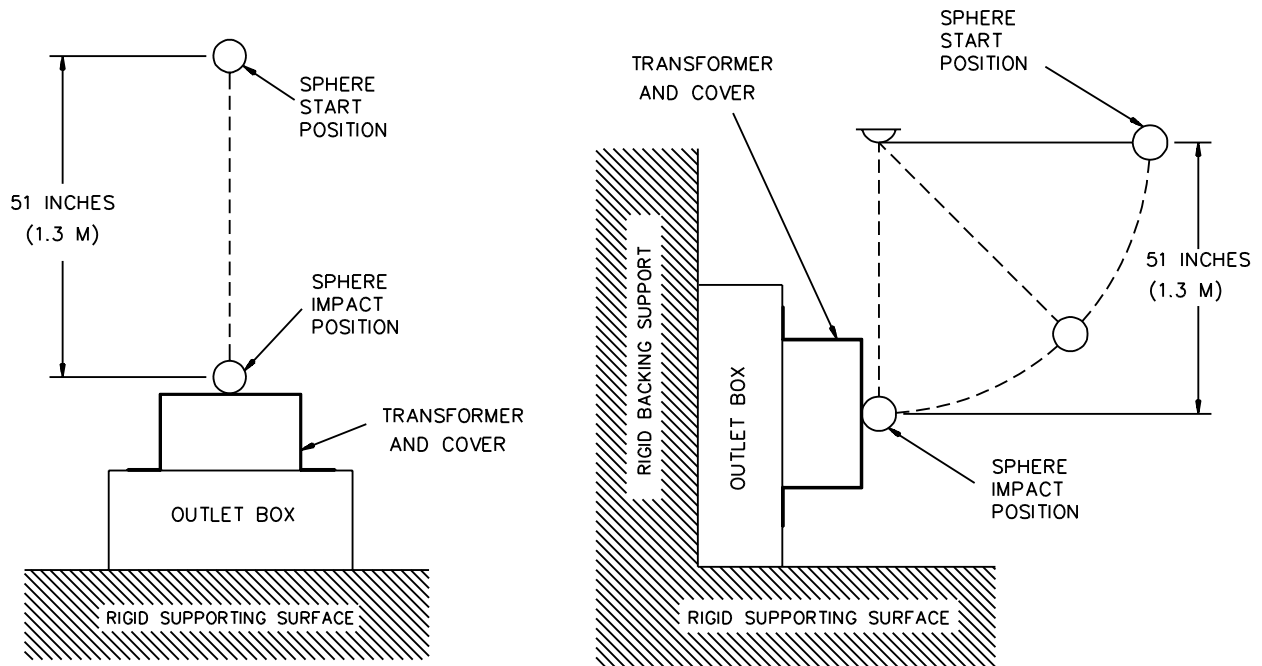

S2896

NOTES –

- 1) The vertical distance the sphere must travel to produce the desired impact is 51 inches (1.3 m).
- 2) For the ball-pendulum impact test, the sphere is to contact the test sample when the string is in the vertical position as shown.
- 3) The supporting surface is to consist of a layer of tongue-and-groove oak flooring mounted on two layers of 3/4 inch (19 mm) plywood. The oak flooring is nominally 3/4 inch thick [actual size 3/4 by 2-1/4 inches (19 by 57 mm)]. The assembly is to rest on a concrete floor. An equivalent nonresilient supporting surface may be used.
- 4) The backing surface is to consist of 3/4 inch plywood over a rigid surface of concrete. An equivalent nonresilient backing surface may be used.

## MANUFACTURING AND PRODUCTION TESTS

### 38 Production-Line Dielectric Voltage-Withstand Test

38.1 As a routing production line test, each transformer shall be subjected to the application of a potential at a frequency within the range of 40 – 70 hertz:

- a) Between the primary wiring, including connected components, and accessible dead metal parts that are likely to become energized and
- b) Between primary wiring and accessible, low-voltage metal parts, including terminals.

There shall be no dielectric breakdown.

38.2 The applied potential for the test is to be 1000 volts for 60 seconds or 1200 volts for 1 second.

38.3 The transformer may be in a heated or unheated condition for the test.

38.4 The test is to be conducted when the transformer is fully assembled. It is not intended that the unit be unwired, modified, or disassembled for the test.

*Exception No. 1: A part such as a snap cover or a friction-fit knob that would interfere with the test need not be in place.*

*Exception No. 2: The test may be conducted before final assembly if the test represents that for the completed transformer.*

38.5 The test equipment is to include a transformer having:

- a) An essentially sinusoidal output;
- b) A means of indicating the test potential;
- c) An audible or visible indicator of dielectric breakdown; and
- d) Either a manual-reset device to restore the equipment after dielectric breakdown, or an automatic-reject feature activated by any unit that fails this test.

38.6 When the output of the test equipment transformer is less than 500 volt-amperes, the equipment shall include a voltmeter in the output circuit to indicate the test potential directly.

38.7 When the output of the test equipment transformer is 500 volt-amperes or more, the test potential may be indicated by:

- a) A voltmeter in the primary circuit or in a tertiary winding circuit;
- b) A selector switch marked to indicate the test potential; or
- c) In the case of equipment having a single test potential output, a marking in a readily visible location to indicate the test potential.

When a marking is used without an indicating voltmeter, the equipment shall include a positive means, such as an indicator lamp, to indicate that the manually reset switch has been reset following a dielectric breakdown.

38.8 Test equipment other than that described in 38.6 and 38.7 may be used if the intended factory control is accomplished.

### **39 Production-Line Grounding Continuity Test**

39.1 Each transformer that has a power supply cord having a grounding conductor shall be tested, as a routine production-line test, to determine that grounding continuity exists between the grounding blade of the attachment-plug and the accessible, dead-metal parts of the transformer that are likely to become energized.

39.2 Only a single test need be conducted if the accessible metal selected is conductively connected by design to all other accessible metal.

39.3 Any indicating device such as an ohm-meter or a battery-and-buzzer combination may be used to determine compliance with 39.1.

## **RATINGS**

### **40 Details**

40.1 The electrical ratings of a transformer shall include the primary voltage and frequency and the voltage and volt-amperes or amperes for each secondary winding. The ratings shall be in accordance with Table 27.3.

40.2 The primary voltage rating of a Class 3 transformer supplied by means of a flexible cord shall be 120 volts.

40.2 revised February 28, 2001

40.3 The secondary voltage rating of each secondary winding of a Class 2 transformer shall not be more than 30 volts rms.

40.4 When the open circuit secondary voltage of a winding of a Class 2 transformer exceeds 21.2 volts peak, the secondary voltage rating of the winding shall be greater than 15 volts rms and the transformer shall be marked in accordance with 41.13.

40.5 The secondary voltage rating of each secondary winding of a Class 3 transformer shall not exceed 100 volts rms when the transformer is inherently limited and shall not exceed 150 volts rms when the transformer is not inherently limited.

## MARKINGS

### 41 Details

41.1 A transformer shall be legibly and permanently marked with the manufacturer's name, trade name, or trademark; the date or other dating period of manufacture not exceeding any three consecutive months; a distinctive catalog number or the equivalent; and the electrical rating.

*Exception No. 1: The manufacturer's identification may be in a traceable code if the transformer is identified by the brand or trademark owned by a private labeler.*

*Exception No. 2: The date of manufacture may be abbreviated or in a nationally accepted conventional code, or in a code affirmed by the manufacturer when:*

*a) The date code does not repeat in less than 25 years.*

*b) The date code does not require reference to the manufacturer's records to determine when the product was manufactured.*

41.2 For transformers intended for use in equipment covered by separate requirements, required markings other than the manufacturer's name and catalog number may be on the end product.

41.3 When a manufacturer produces transformers at more than one factory, each finished transformer shall have a distinctive marking – which may be in code – to identify it as the product of a particular factory.

41.4 A required marking shall be molded, die stamped, paint stenciled, stamped or etched on metal, or indelibly stamped on pressure sensitive labels secured by adhesive. Pressure sensitive labels secured by adhesive shall comply with the applicable portions of the Standard for Marking and Labeling Systems, UL 969. Ordinary usage, handling, or storage of the transformer shall be considered when determining the permanence of marking.

41.5 A Class 2 or a Class 3 transformer shall be marked with the words "Class 2" or "Class 3," respectively, or as described in 41.13.

41.6 A transformer shall be plainly marked to indicate which terminals (or leads) are for primary and which are for secondary windings. Secondary winding connections shall be identified from each other.

*Exception: A Class 3 transformer supplied with a flexible cord and attachment plug need not be marked to distinguish between primary and secondary.*

41.6 revised February 28, 2001

41.7 A transformer with multiple secondary windings (as described in 3.1) having an output exceeding 21.2 or 42.4 volts peak as described in 26.1, or a transformer with an output current exceeding the limit specified in 27.1.1 or 27.3.1, shall be marked where readily visible after installation, with the word "WARNING" and the following or the equivalent: "Risk of electric shock or fire, do not interconnect secondary windings." The word "WARNING" shall be in letters not less than 1/8 inch (3.2 mm) high. The remaining letters shall be not less than 1/16 inch (1.6 mm) high.



41.8 The marking specified in 41.7 shall be located on the transformer or on a tag complying with the requirements in 41.9 and 41.10.

41.9 The marking specified in 41.7 may be provided on a permanent tag that is secured to the transformer or supply cord. The tag shall be attached so it cannot be easily removed. The tag shall also be marked "Do not remove this tag" or the equivalent, in letters not less than 3/32 inch (2.4 mm) high.

41.10 The tag mentioned in 41.9 shall be made of durable material that provides mechanical strength, such as cloth, plastic, or the equivalent, and shall be large enough to fit the required marking.

41.11 A transformer with primary field-wiring terminals intended for use with copper and aluminum conductors shall be marked "Use copper or aluminum wire."

41.12 A transformer with primary field-wiring terminals intended for use with copper wire only shall be marked "Use copper wire only." When the field-wiring terminals are intended for aluminum wire only, the transformer shall be marked "Use aluminum wire only."

No Text on This Page

41.13 When the open circuit secondary voltage of a transformer exceeds 15 volts rms or 21.2 volts peak but does not exceed 30 volts rms or 42.4 volts peak, the transformer shall be marked "Class 2 not wet, Class 3 wet" or the equivalent to indicate that Class 3 wiring methods are required to be used, in accordance with Article 725 of the National Electrical Code, ANSI/NFPA 70, (if the wiring extends into areas where wet contact is likely).

41.13 revised May 24, 1999

41.14 When a replaceable protective device is incorporated in a Class 2 transformer and relied upon to comply with any requirement contained in this standard, the transformer shall be legibly marked to indicate the proper replacement part and procedure. The marking shall be visible when accessing the protective device.

41.15 When more than one primary circuit wire connector is provided at a single connection point, each connector shall be identified as to the wire size or range of wire sizes for which it is appropriate.

41.16 If, during the rated output heating test, the temperature rise on a field installed lead or on any part within the compartment that the lead might contact is more than 35°C (63°F), the transformer shall be marked with the following statement or the equivalent, at or near the point where field connections will be made, and located so that it will be readily visible during installation: "Use wire rated for at least \_\_\_\_°C." The temperature value to be used in the preceding statement shall be in accordance with Table 41.1.

**Table 41.1**  
**Wiring compartment marking**

Temperature rise attained during test				Value to be used in marking indicated in 41.16, °C
More than,		But not more than,		
°C	(°F)	°C	(°F)	
35	63	50	90	75
50	90	65	117	90

41.17 A transformer rated less than 110 volts and not intended for use on a 110 – 120 volt circuit shall be marked "For use only on \_\_\_\_-volt circuits." The blank space is to be replaced with the intended voltage.

41.18 With reference to 11.8, a Class 2 or Class 3 transformer intended for installation with open wiring or concealed knob-and-tube wiring in accordance with Articles 320 and 324 of the National Electrical Code, ANSI/NFPA 70, shall be marked where readily visible "Suitable for use in accordance with Articles 320 and 324 of the NEC."

41.18 revised May 24, 1999

41.19 In accordance with 15.8, if a transformer is intended for mounting in a knockout and there is no means for maintaining a bonding path between the transformer and the equipment grounding conductor when the transformer is installed in a nonmetallic box, the transformer shall be marked "Install in Metal Box Only."

No Text on This Page

## APPENDIX A

### Standards for Components

Standards under which components of the products covered by this standard are evaluated include the following:

Title of Standard – UL Standard Designation

---

Attachment Plugs and Receptacles – UL 498  
Cord Sets and Power-Supply Cords – UL 817  
Double Insulation Systems for Use in Electrical Equipment – UL 1097  
Fittings for Cable and Conduit – UL 514B  
Flexible Cord and Fixture Wire – UL 62  
Low-Voltage Fuses – Part 1: General Requirements – UL 248-1  
Low-Voltage Fuses – Part 14: Supplemental Fuses – UL 248-14  
Marking and Labeling Systems – UL 969  
Metallic Outlet Boxes – UL 514A  
Nonmetallic Outlet Boxes, Flush-Device Boxes, and Covers – UL 514C  
Polymeric Materials – Fabricated Parts – UL 746D  
Polymeric Materials – Long Term Property Evaluations – UL 746B  
Polymeric Materials – Short Term Property Evaluations – UL 746A  
Polymeric Materials – Use in Electrical Equipment Evaluations – UL 746C  
Systems of Insulating Materials – General – UL 1446  
Temperature-Indicating and -Regulating Equipment – UL 873  
Terminal Blocks – UL 1059  
Thermal Cutoffs for Use in Electrical Appliances and Components – UL 1020  
Tubing, Extruded Insulating – UL 224  
Wire Connectors – UL 486A-UL 486B  
Wires and Cables, Thermoplastic-Insulated – UL 83  
Wires and Cables, Thermoset-Insulated – UL 44

No Text on This Page