

UL 917

ISBN 1-55989-639-6

# Clock-Operated Switches



---

Underwriters Laboratories Inc. (UL)  
333 Pfingsten Road  
Northbrook, IL 60062-2096

UL Standard for Safety  
for  
Clock-Operated Switches, UL 917

Fourth Edition, Dated July 14, 1994

Revisions: This Standard contains revisions through and including February 27, 1998. UL is in the process of converting its Standards for Safety to the Standard Generalized Markup Language (SGML). SGML – an international standard (ISO 8879-1986) – is a descriptive markup language that describes a document's structure and purpose, rather than its physical appearance on the page. The more significant benefits that will result from UL's use of SGML are increased productivity and reduced turnaround times; and data and information consistency, reusability, shareability, and portability. The changes contained in these revised pages are needed to modify the format and layout of this Standard to allow it to be converted to SGML. These are editorial changes now in effect.

A change is indicated by a note following the affected item. The note is preceded and followed by an asterisk.

The revisions dated February 27, 1998 include a reprinted title page (page 1) for this Standard.

As indicated on the title page (page 1), this UL Standard for Safety is an American National Standard. Attention is directed to the note on the title page of this Standard outlining the procedures to be followed to retain the approved text of this ANSI/UL Standard.

As indicated on the title page (page 1), this UL Standard for Safety has been adopted by the Department of Defense.

The master for this Standard at UL's Northbrook Office is the official document insofar as it relates to a UL service and the compliance of a product with respect to the requirements for that product and service, or if there are questions regarding the accuracy of this Standard.

UL's Standards for Safety are copyrighted by UL. Neither a printed copy of a Standard, nor the distribution diskette for a Standard-on-Diskette and the file for the Standard on the distribution diskette should be altered in any way. All of UL's Standards and all copyrights, ownerships, and rights regarding those Standards shall remain the sole and exclusive property of UL.

All rights reserved. No part of this publication may be reproduced, stored in a retrieval system, or transmitted in any form by any means, electronic, mechanical photocopying, recording, or otherwise without prior permission of UL.

Revisions of UL Standards for Safety are issued from time to time. A UL Standard for Safety is current only if it incorporates the most recently adopted revisions.

UL provides this Standard "as is" without warranty of any kind, either expressed or implied, including but not limited to, the implied warranties of merchantability or fitness for any purpose.

In no event will UL be liable for any special, incidental, consequential, indirect or similar damages, including loss of profits, lost savings, loss of data, or any other damages arising out of the use of or the inability to use this Standard, even if UL or an authorized UL representative has been advised of the possibility of such damage. In no event shall UL's liability for any damage ever exceed the price paid for this Standard, regardless of the form of the claim.

UL will attempt to answer support requests concerning WordPerfect, Envoy, and Standards-on-Diskette. However, this support service is offered on a reasonable efforts basis only, and UL may not be able to resolve every support request. UL supports a Standards-on-Diskette only if it is used under the conditions and operating systems for which it is intended. UL's support policies may change from time-to-time without notification.

UL reserves the right to change the format, presentation, file types and formats, delivery methods and formats, and the like of both its printed and electronic Standards without prior notice.

Standards-on-Diskette purchasers agree to defend, indemnify, and hold UL harmless from and against any loss, expense, liability, damage, claim, or judgement (including reasonable attorney's fees) resulting from any error or deviation introduced while purchaser is storing a Standard-on-Diskette on the purchaser's computer system.

If a single-user version Standards-on-Diskette was purchased, one copy of this Standard may be stored on the hard disk of a single personal computer, or on a single LAN file-server or the permanent storage device of a multiple-user computer in such a manner that this Standard may only be accessed by one user at a time and for which there is no possibility of multiple concurrent access. The original distribution diskette should be stored in a safe place.

If a multiple-user version Standards-on-Diskette was purchased, one copy of the Standard may be stored on a single LAN file-server, or on the permanent storage device of a multiple-user computer. The number of concurrent users shall not exceed the number of users authorized for the Standards-on-Diskette version. The original distribution diskette should be stored in a safe place.

Standards-on-Diskette are intended for on-line use, such as for viewing the requirements of a Standard, conducting a word search, and the like. Only one copy of the Standard may be printed from each single-user version of a Standards-on-Diskette. Only one copy of the Standard may be printed for each authorized user of a multiple-user version of a Standards-on-Diskette. An employee of an organization purchasing a Standard-on-Diskette can make a copy of the page or pages being viewed for their own fair and/or practical internal use. Because of differences in the computer/software/printer setup used by UL and those of Standards-on-Diskette purchasers, the printed copy obtained by a purchaser may not look exactly like the on-line screen view or the printed Standard.

The requirements in this Standard are now in effect, except for those paragraphs, sections, tables, figures, and/or other elements of the Standard having future effective dates as indicated in the note following the affected item. The prior text for requirements that have been revised and that have a future effective date are located after the Standard, and are preceded by a "SUPERSEDED REQUIREMENTS" notice.

New product submittals made prior to a specified future effective date will be judged under all of the requirements in this Standard including those requirements with a specified future effective date, unless the applicant specifically requests that the product be judged under the current requirements. However, if the applicant elects this option, it should be noted that compliance with all the requirements in this Standard will be required as a condition of continued Recognition and Follow-Up Services after the effective date, and understanding of this should be signified in writing.

---

This Standard consists of pages dated as shown in the following checklist:

Page	Date
tr1 – tr4 .....	February 27, 1998
1 .....	July 14, 1994 (Reprinted February 27, 1998)
2 – 16 .....	July 14, 1994
17, 18 .....	April 10, 1996
19 – 33 .....	July 14, 1994
34, 34A, 34B .....	February 27, 1998
35 – 47 .....	July 14, 1994
48, 48A, 48B .....	February 27, 1998
49 – 58, sr1, sr2 .....	July 14, 1994

No Text on This Page

**JULY 14, 1994**  
(Title Page Reprinted: February 27, 1998)

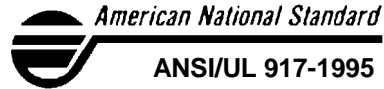

1

**HISTORICAL NOTE**

**UL 917**

**Standard for**

**Clock-Operated Switches**

First Edition – August, 1974  
Second Edition - April, 1977  
Third Edition - May, 1985

**Fourth Edition**

**July 14, 1994**

Approval as an American National Standard (ANSI) covers the numbered paragraphs on pages dated July 14, 1994 and April 10, 1996. These pages should not be discarded when revised or additional pages are issued if it is desired to retain the ANSI approved text.

An effective date included as a note immediately following certain requirements is one established by Underwriters Laboratories Inc.

Approved as ANSI/UL C33.130-1976, October 18, 1976  
Approved as ANSI/UL 917-1985, February 15, 1985  
Reaffirmed as ANSI/UL 917-1985 (R1990), January 8, 1990  
Approved as ANSI/UL 917-1995, November 15, 1995

Revisions of this standard will be made by issuing revised or additional pages bearing their date of issue. A UL Standard is current only if it incorporates the most recently adopted revisions, all of which are itemized on the transmittal notice that accompanies the latest set of revised requirements.

**ISBN 1-55989-639-6**

**COPYRIGHT © 1974, 1996 UNDERWRITERS LABORATORIES INC.**

---

## CONTENTS

### FOREWORD

### INTRODUCTION

1 Scope .....	5
2 Glossary .....	5
3 Components .....	6
4 Units of Measurement .....	6
5 References .....	6

### CONSTRUCTION

6 Frame and Enclosure .....	7
7 Rainproof Enclosures .....	16
8 Mounting .....	18
9 Assembly .....	20
10 Operating Mechanism .....	20
11 Corrosion Protection .....	21
12 Insulating Material .....	21
13 Field Connections .....	22
14 Supply Connections .....	22
15 Cord-Connected Devices .....	24
16 Grounding .....	25
17 Receptacles .....	26
18 Bonding of Internal Parts .....	27
19 Current-Carrying Parts .....	28
20 Internal Wiring .....	29
21 Coil Windings .....	30
22 Spacings .....	30
23 Field-Wiring Space .....	33

### PERFORMANCE

24 General .....	33
25 Leakage Current Test .....	33
26 Temperature Test .....	35
27 Overload Test .....	39
28 Endurance Test .....	43
29 Tungsten-Filament-Lamp Load Test .....	45
30 Test Conditions .....	46
31 Rain Test .....	46
32 Dielectric Voltage-Withstand Test .....	49
33 Impact Test .....	49
34 Metallic Coating Thickness Test .....	50
35 Gasket Tests .....	51
36 Grounding Resistance Test .....	51
37 Strain Relief Test .....	52
38 Snap-On Cover Tests .....	52
39 Knockout Secureness Test .....	52
40 Humidity Test .....	52
41 Abnormal Operation Test .....	53



**RATINGS**

42 Details ..... 53

**MARKINGS**

43 Details ..... 53

**TV RATED SWITCHES**

**GENERAL**

44 Details ..... 55

**CONSTRUCTION**

45 Enclosure ..... 56

**PERFORMANCE**

46 General ..... 56  
 47 Test Circuit ..... 57  
 48 Test Conditions ..... 57  
 49 Overload Test ..... 57  
 50 Endurance Test ..... 58  
 51 Temperature Test ..... 58  
 52 Dielectric Voltage-Withstand Test ..... 58  
 53 Continued Endurance Test ..... 58  
 54 Dielectric Voltage-Withstand Test (Repeated) ..... 58

**RATINGS**

55 Details ..... 58

**MARKINGS**

56 Details ..... 58

## FOREWORD

A. This Standard contains basic requirements for products covered by Underwriters Laboratories Inc. (UL) under its Follow-Up Service for this category within the limitations given below and in the Scope section of this Standard. These requirements are based upon sound engineering principles, research, records of tests and field experience, and an appreciation of the problems of manufacture, installation, and use derived from consultation with and information obtained from manufacturers, users, inspection authorities, and others having specialized experience. They are subject to revision as further experience and investigation may show is necessary or desirable.

B. The observance of the requirements of this Standard by a manufacturer is one of the conditions of the continued coverage of the manufacturer's product.

C. A product which complies with the text of this Standard will not necessarily be judged to comply with the Standard if, when examined and tested, it is found to have other features which impair the level of safety contemplated by these requirements.

D. A product employing materials or having forms of construction differing from those detailed in the requirements of this Standard may be examined and tested according to the intent of the requirements and, if found to be substantially equivalent, may be judged to comply with the Standard.

E. UL, in performing its functions in accordance with its objectives, does not assume or undertake to discharge any responsibility of the manufacturer or any other party. The opinions and findings of UL represent its professional judgment given with due consideration to the necessary limitations of practical operation and state of the art at the time the Standard is processed. UL shall not be responsible to anyone for the use of or reliance upon this Standard by anyone. UL shall not incur any obligation or liability for damages, including consequential damages, arising out of or in connection with the use, interpretation of or reliance upon this Standard.

F. Many tests required by the Standards of UL are inherently hazardous and adequate safeguards for personnel and property shall be employed in conducting such tests.

---

## INTRODUCTION

### 1 Scope

1.1 These requirements cover clock-operated switches rated 600 V or less, to be used in ordinary locations designed to close and open circuits to a load at predetermined intervals, and intended to be employed in accordance with the National Electrical Code, ANSI/NFPA 70.

1.2 These requirements cover only clock-operated switches in which the switching contacts are actuated by a clock-work, by a gear-train, by hand, by electrically-wound spring motors, by electric clock-type motors, or by equivalent arrangements. In addition to closing and opening the switching contacts, the devices may also indicate the time of day or time interval.

1.3 These requirements do not cover devices incorporating electronic timing circuits or switching circuits without separable contacts.

1.4 A clock-operated switch, which is incomplete in construction features or restricted in performance capabilities, is acceptable for use as a factory-installed component provided that the restrictions established for the component are eliminated when the component is installed.

1.5 Specific provisions are included in these requirements for TV rated clock-operated switches.

1.6 A product that contains features, characteristics, components, materials or systems new or different from those covered by the requirements in this Standard, and that involves a risk of fire, electric shock, or injury to persons shall be evaluated using the appropriate additional component and end-product requirements as determined necessary to maintain the acceptable level of safety as originally anticipated by the intent of this Standard. A product whose features, characteristics, components, materials, or systems conflict with specific requirements or provisions of this Standard cannot be judged to comply with this Standard. Where considered appropriate, revision of requirements shall be proposed and adopted in conformance with the methods employed for development, revision, and implementation of this Standard.

### 2 Glossary

2.1 For the purpose of this standard the following definitions apply.

2.2 ACCESSIBLE PART – A part so located that it can be contacted by a person, either directly or by means of a probe or tool.

2.3 LEAKAGE CURRENT – Leakage current refers to all currents, including capacitively coupled currents, that may be conveyed between exposed conductive surfaces of an appliance and ground or other exposed conductive surfaces of a device.

2.4 LIVE PARTS – Denotes metal or other conductive parts that have a potential difference with respect to ground or any other conductive part in intended use.

2.5 LOW-VOLTAGE CIRCUIT – A circuit classified as low voltage is one involving a potential of not more than 42.4 V peak (30 V rms) and supplied by a primary battery, by a standard Class 2 transformer, or by a combination of a transformer and a fixed impedance, which, as a unit, complies with all the performance requirements for a Class 2 transformer.

2.6 OPERATING CONTROL – A control, usually a knob, push button, or lever, provided to enable the user to cause the device to perform its intended function, without the use of tools, when the device is in the operating condition.

2.7 PERMANENTLY CONNECTED – Denotes connection to a supply circuit by way of fixed electrical conductors.

2.8 PILOT DUTY – An application involving the control of an electromagnet.

2.9 PLUG-IN DEVICE – A device provided with integral blades for direct insertion into a receptacle.

2.10 RAINPROOF – So constructed, protected, or treated as to prevent rain from interfering with successful operation of the device under specified test conditions.

2.11 SWITCH – Usage of the word switch without further qualification signifies a clock-operated switch in subsequent paragraphs of this standard.

### **3 Components**

3.1 Except as indicated in 3.2, a component of a product covered by this standard shall comply with the requirements for that component.

3.2 A component need not comply with a specific requirement that:

- a) Involves a feature or characteristic not needed in the application of the component in the product covered by this standard, or
- b) Is superseded by a requirement in this standard.

3.3 A component shall be used in accordance with its recognized rating established for the intended conditions of use.

3.4 Specific components are recognized as being incomplete in construction features or restricted in performance capabilities. Such components are intended for use only under limited conditions, such as certain temperatures not exceeding specified limits and shall be restricted to use only under those specific conditions for which they have been recognized.

### **4 Units of Measurement**

4.1 If a value for measurement is followed by a value in other units in parentheses, the second value may be only approximate. The first stated value is the requirement.

### **5 References**

5.1 Any undated reference to a code or standard appearing in the requirements of this standard shall be interpreted as referring to the latest edition of that code or standard.

## CONSTRUCTION

### 6 Frame and Enclosure

#### 6.1 General

6.1.1 The frame and enclosure shall be strong and rigid to resist the abuses likely to be encountered during service. The degree of structural integrity inherent in the unit shall preclude total or partial collapse with the attendant reduction of spacings, loosening or displacement of parts, and other serious defects that alone or in combination constitute an increase in the risk of fire, electric shock, or injury to persons.

6.1.2 Electrical parts of a clock-operated switch shall be located or enclosed to reduce the risk of unintentional contact with an uninsulated live part. For the purpose of these requirements, film-coated wire is considered to be an uninsulated live part.

*Exception: An enclosure is not required for a device intended for assembly as part of another device.*

\*Revised 6.1.2 effective December 17, 1997\*

6.1.3 An opening in an enclosure or a clock-operated switch is acceptable if an accessibility probe as illustrated in Figure 6.1, when inserted into the opening, cannot be made to touch any part that involves the risk of electric shock to the end-user or service personnel. However, in no case shall the opening be large enough to permit the entrance of a 1 inch (25.4 mm) diameter rod.

\*Revised 6.1.3 effective December 17, 1997\*

6.1.4 The accessibility probe shall be articulated into any configuration and shall be rotated or angled to any position before, during, or after insertion into the opening, and the penetration shall be to any depth allowed by the opening size, including minimal depth combined with maximum articulation.

\*Added 6.1.4 effective December 17, 1997\*

6.1.5 If any part of the enclosure must be opened or removed as part of normal operation, regular adjustment, or regular or required maintenance (set point adjustment, timer or time of day clock adjustment, battery replacement, and the like) with or without the use of tools, or can be opened or removed without the use of tools, the accessibility probe is to be applied without the part in place.

*Exception: An enclosure employing a snap-on cover as indicated in 6.5.2 need not comply with this requirement.*

\*Revised 6.1.5 effective December 17, 1997\*

6.1.6 Moving parts of a switch such as rotors of motors, clock works, or gear trains, shall be located or enclosed to reduce the risk of injury to persons.

6.1.7 If a marking draws attention of the user to a hole of any size in the enclosure for an adjustment, it shall not be possible to damage insulation or film-coated wire, or contact uninsulated live parts through the hole with a 1/16-inch-diameter (1.6 mm) rod.

Figure 6.1  
Accessibility probe

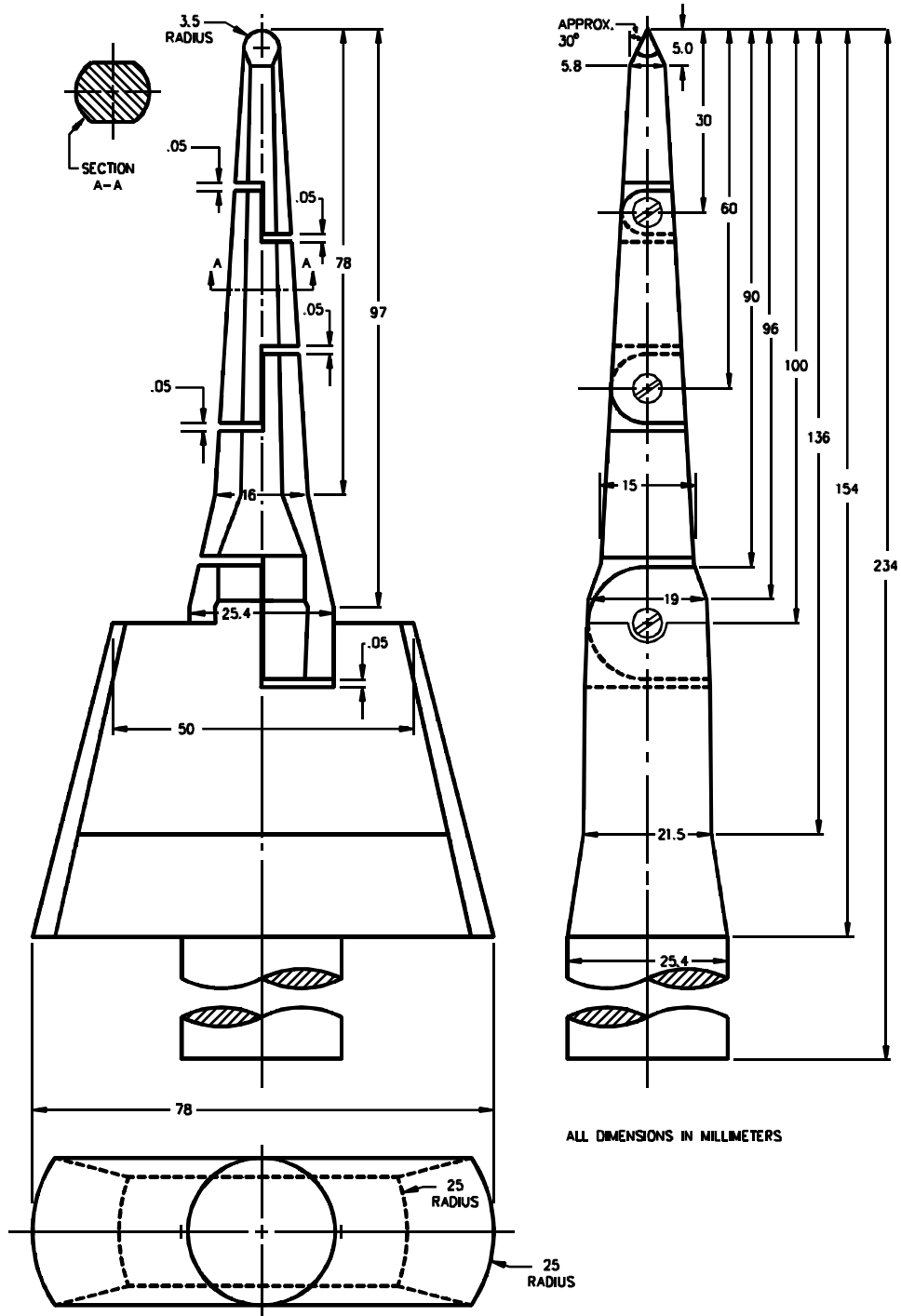

PA100A

\*Revised Figure 6.1 effective December 17, 1997\*

## 6.2 Nonmetallic

6.2.1 Among the factors that are taken into consideration in determining the acceptability of a nonmetallic enclosure or frame or an enclosure or frame of magnesium are:

- a) Mechanical strength
- b) Resistance to impact
- c) Moisture-absorptive properties
- d) Combustibility
- e) Resistance to arcing
- f) Resistance to temperatures to which the material might be subjected under conditions of normal or abnormal use.
- g) Aging characteristics

6.2.2 A nonmetallic enclosure as indicated in 6.2.1 shall withstand a single impact of 5 ft-lbf (6.8 J) as described in 33.1 without introducing a risk of fire, electric shock, or injury to persons.

## 6.3 Cast metal

6.3.1 Cast metal for an enclosure shall be at least 1/8 inch (3.2 mm) thick at every point, of greater thickness at reinforcing ribs and door edges, and not less than 1/4 inch (6.4 mm) thick at tapped holes for conduit; except that, other than at plain or threaded conduit holes, die-cast metal shall not be less than 3/32 inch (2.4 mm) thick for an area greater than 24 in<sup>2</sup> (0.0155 m<sup>2</sup>) or having any dimension greater than 6 inch (152 mm) and shall not be less than 1/16 inch (1.6 mm) thick for an area of 24 in<sup>2</sup> or less and having no dimensions greater than 6 inch. The area limitation for metal 1/16 inch thick may be obtained by the provision of reinforcing ribs subdividing a larger area.

6.3.2 A knockout in a die-cast metal enclosure for conduit connection of 1 inch trade size or smaller conduit, shall not be less than 1/16 inch (1.6 mm) thick and the narrow section around the periphery that is reduced in thickness for ease in breaking out shall not be less than 0.020 inch (0.51 mm) thick.

6.3.3 Consideration is to be given to the number of such knockouts required to connect the device in the manner intended. The number of knockouts provided is not to affect the structural integrity or result in unused openings.

## 6.4 Sheet metal

6.4.1 The thickness of a sheet-metal enclosure shall be as indicated in Tables 6.1 and 6.2 except that steel shall not be less than 0.032 inch (0.81 mm) thick – 0.034 inch (0.86 mm) if zinc coated – and nonferrous metal shall not be less than 0.045 inch (1.14 mm) thick at points where a wiring system is to be connected in the field.

6.4.2 Tables 6.1 and 6.2 are based on a uniform deflection of the enclosure surface for any given load concentrated at the center of the surface regardless of metal thickness.

**Table 6.1**  
**Minimum thickness of sheet metal for enclosures**  
**carbon steel or stainless steel**

Without supporting frame <sup>a</sup>		Without supporting frame or equivalent reinforcing <sup>a</sup>		Minimum thickness in inches (mm)			
Maximum width <sup>b</sup>		Maximum length <sup>c</sup>		Uncoated	Zinc coated		
inches	(cm)	inches	(cm)			inches	(cm)
4.0	( 10.2)	Not limited		0.020 <sup>d</sup>	(0.51) <sup>d</sup>	0.023 <sup>d</sup>	(0.58) <sup>d</sup>
4.75	( 12.1)	5.75	( 14.6)	6.75	( 17.1)	8.25	( 21.0)
6.0	( 15.2)	Not limited		9.5	( 24.1)	Not limited	
7.0	( 17.8)	8.75	( 22.2)	10.0	( 25.4)	12.5	( 31.8)
8.0	( 20.3)	Not limited		12.0	( 30.5)	Not limited	
9.0	( 22.9)	11.5	( 29.2)	13.0	( 33.0)	16.0	( 40.6)
12.5	( 31.8)	Not limited		19.5	( 49.5)	Not limited	
14.0	( 35.6)	18.0	( 45.7)	21.0	( 53.3)	25.0	( 63.5)
18.0	( 45.7)	Not limited		27.0	( 68.6)	Not limited	
20.0	( 50.8)	25.0	( 63.5)	29.0	( 73.7)	36.0	( 91.4)
22.0	( 55.9)	Not limited		33.0	( 83.8)	Not limited	
25.0	( 63.5)	31.0	( 78.7)	35.0	( 88.9)	43.0	(109.2)
25.0	( 63.5)	Not limited		39.0	( 99.1)	Not limited	
29.0	( 73.7)	36.0	( 91.4)	41.0	(104.1)	51.0	(129.5)

<sup>a</sup> See 6.4.3.

<sup>b</sup> The width is the smaller dimension of a rectangular piece of sheet metal that is part of an enclosure. Adjacent surfaces of an enclosure may have supports in common and be made of a single sheet.

<sup>c</sup> For panels that are not supported along one side, for example, side panels of boxes, the length of the unsupported side shall be limited to the dimensions specified.

<sup>d</sup> Sheet steel for an enclosure intended for outdoor use (rainproof) shall not be less than 0.034 inch (0.86 mm) thick if zinc coated and not less than 0.032 inch (0.81 mm) thick if uncoated.



**Table 6.2**  
**Minimum thickness of sheet metal for enclosures**  
**aluminum, copper, or brass**

Without supporting frame <sup>a</sup>		Without support frame or equivalent reinforcing <sup>a</sup>				
Maximum width <sup>b</sup>	Maximum length <sup>c</sup>	Maximum width <sup>b</sup>	Maximum length	Maximum length	Minimum thickness	
inches (cm)	inches (cm)	inches (cm)	inches (cm)	inches (cm)	inches (mm)	(mm)
3.0 ( 7.6)	Not limited	7.0 ( 17.8)	Not limited	Not limited	0.23 <sup>d</sup>	(0.58) <sup>d</sup>
3.5 ( 8.9)	4.0 ( 10.2)	8.5 ( 21.6)	9.5 ( 24.1)	9.5 ( 24.1)		
4.0 ( 10.2)	Not limited	10.0 ( 25.4)	Not limited	Not limited	0.029 <sup>d</sup>	(0.74)
5.0 ( 12.7)	6.0 ( 15.2)	10.5 ( 26.7)	13.5 ( 34.3)	13.5 ( 34.3)		
6.0 ( 15.2)	Not limited	14.0 ( 35.6)	Not limited	Not limited	0.036	(0.91)
6.5 ( 16.5)	8.0 ( 20.3)	15.0 ( 38.1)	18.0 ( 45.7)	18.0 ( 45.7)		
8.0 ( 20.3)	Not limited	19.0 ( 48.3)	Not limited	Not limited	0.045	(1.14)
9.5 ( 24.1)	11.5 ( 29.2)	21.0 ( 53.3)	25.0 ( 63.5)	25.0 ( 63.5)		
12.0 ( 30.5)	Not limited	28.0 ( 71.1)	Not limited	Not limited	0.058	(1.47)
14.0 ( 35.6)	16.0 ( 40.6)	30.0 ( 76.2)	37.0 ( 94.0)	37.0 ( 94.0)		
18.0 ( 45.7)	Not limited	42.0 (106.7)	Not limited	Not limited	0.075	(1.91)
20.0 ( 50.8)	25.0 ( 63.5)	45.0 (114.3)	55.0 (139.7)	55.0 (139.7)		
25.0 ( 63.5)	Not limited	60.0 (152.4)	Not limited	Not limited	0.095	(2.41)
29.0 ( 73.7)	36.0 ( 91.4)	64.0 (162.6)	78.0 (198.1)	78.0 (198.1)		

<sup>a</sup> See 6.4.3.

<sup>b</sup> The width is the smaller dimension of a rectangular piece of sheet metal that is part of an enclosure. Adjacent surfaces may have supports in common and be made of a single sheet.

<sup>c</sup> For panels that are not supported along one side, for example, side panels of boxes, the length of the unsupported side shall be limited to the dimensions specified.

<sup>d</sup> Sheet copper, brass, or aluminum for an enclosure intended for outdoor use (rainproof) shall not be less than 0.029 inch thick (0.74 mm).

6.4.3 With reference to Tables 6.1 and 6.2, a supporting frame is a structure of angle or channel or a folded rigid section of sheet metal that is rigidly attached to and has essentially the same outside dimensions as the enclosure surface and that has flexural rigidity to resist the bending moments that may be applied by the enclosure surface when it is deflected. Construction that is considered to have equivalent reinforcing may be accomplished by designs that will produce a structure that is as rigid as one built with a frame of angles or channels. Constructions considered to be without supporting frame include:

- a) A single sheet with single formed flanges (formed edges),
- b) A single sheet that is corrugated or ribbed, or
- c) An enclosure surface loosely attached to a frame, for example, with spring clips.

6.4.4 A part such as a knob, lever, or dial that is being depended upon to obtain compliance with 6.1.1 or 6.1.5 shall be of metal or other material as specified for the enclosure in 6.2.1, 6.3.1, and 6.4.1.

## 6.5 Covers

6.5.1 The enclosure and parts of the enclosure such as doors, covers, and the like shall be provided with means for securing them in place.

6.5.2 A snap-on cover that gives access to uninsulated live parts and does not have a separate tool-operated fastener shall not have any apparent means of removal, such as an extending tab, and shall withstand the tests described in Snap-On Cover Tests, Section 38.

6.5.3 An enclosure cover shall be hinged if it gives access to fuses, thermal cutouts, or any other overload protective device, the normal functioning of which requires renewal.

6.5.4 A hinged cover shall not depend solely upon screws or other similar means requiring the use of a tool to hold it closed, but shall be provided with a spring latch or catch or other hand operable cover securing means.

6.5.5 A door or cover giving access to fuses or thermal cutouts in other than low-voltage circuits shall shut closely against a 1/4 inch (6.4 mm) rabbet or the equivalent, or shall have either turned flanges for the full length of four edges or angle strips fastened to it. Flanges or angle strips shall fit closely with the outside of the walls of the box proper and shall overlap the edges of the box not less than 1/2 inch (12.7 mm). A special construction that affords equivalent protection or a combination of flange and rabbet is acceptable.

6.5.6 Strips used to provide rabbets or angle strips fastened to the edges of a door shall be secured at not less than two points, not more than 1-1/2 inch (38.1 mm) from each end of each strip and at points between these end fastenings not more than 6 inch (152 mm) apart.

## 6.6 Openings

6.6.1 An opening shall not be provided in an enclosure that houses a fuse or any portion of a circuit breaker other than the operating handle, unless the construction affords containment of electrical fault disturbances equivalent to that provided by an enclosure complying with the requirements in 6.5.4 – 6.5.6.

\*Added 6.6.1 effective December 17, 1997\*

6.6.2 The following requirements apply to openings:

- a) An opening shall not be provided in a compartment or part of an enclosure that contains field-wiring splices in a line-voltage circuit.
- b) No openings shall be located in the mounting surface of an enclosure.

*Exception: The following openings may be located in the mounting surface of an enclosure:*

- 1) *A mounting opening.*

- 
- 2) *A maximum of four openings provided for the escape of air or paint during a painting process. The maximum dimension of such an opening shall not exceed 1/8 inch (3.2 mm).*
- 3) *A maximum of four unused holes provided for mounting of internal components. The maximum dimension of such an opening shall not exceed 3/16 inch (4.8 mm).*
- c) If the bottom surface is not the mounting surface, an opening may be provided in the bottom surface of an enclosure if the opening does not permit materials to fall out from the interior of the unit. See Figure 6.2 for an example of a construction complying with this requirement.
- d) The shortest distance between an opening and the bottom of an enclosure or a wall-mounting surface shall be at least one-quarter of the enclosure height or depth, respectively, or 1 inch (25.4 mm), whichever is less.
- e) Air from an opening, either forced or otherwise, shall not be directed:
- 1) Into a duct or into a concealed space in a building,
  - 2) Against the mounting surface, or
  - 3) So that a disturbance would be propagated to other equipment.
- f) Not more than four holes for mounting an enclosure having a maximum dimension of 18 inches (457 mm); six holes for an enclosure with a maximum dimension of more than 18 inches, but less than 48 inches (1.2 m); eight holes for an enclosure with a maximum dimension of 48 inches or more. Four of the holes for mounting an enclosure with a maximum dimension of 12 inches (305 mm) may be keyhole slots having the configuration illustrated in Figure 6.3. The dimensions shown in Figure 6.3 may vary if the area is equivalent. Four of the holes for mounting a larger enclosure may be keyhole slots, the dimensions of which are not specified, and which shall be judged with regard to the enclosure dimensions and configuration.

\*Added 6.6.2 effective December 17, 1997\*

6.6.3 The smaller dimension (width) of an opening in an enclosure around a dial, adjusting knob, lever, handle, pointer, or the like shall not be more than 1/8 inch (3.2 mm) for any setting or position of the dial, knob, and the like.

\*Added 6.6.3 effective December 17, 1997\*

**Figure 6.2**  
**Bottom panel baffles**

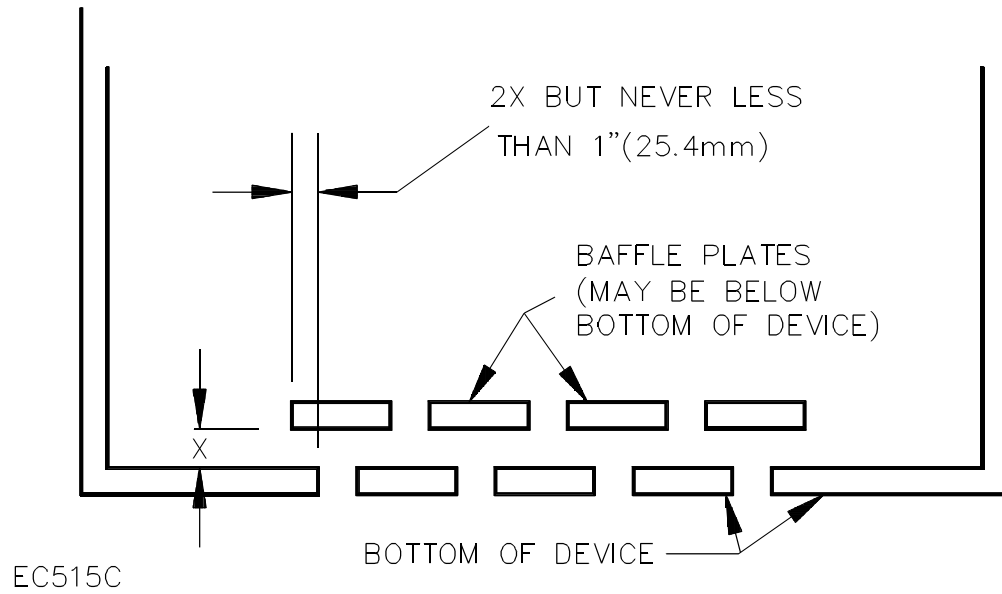

\*Added Figure 6.2 effective December 17, 1997\*

**Figure 6.3**  
**Keyhole slot**

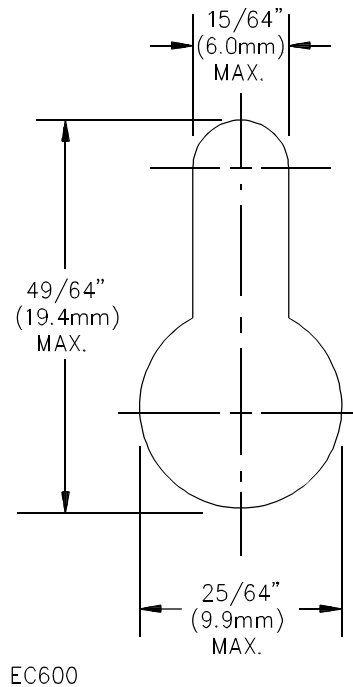

\*Added Figure 6.3 effective December 17, 1997\*

## 6.7 Screens and expanded metal

6.7.1 The wires of a screen shall not be less than No. 16 AWG ( $1.3 \text{ mm}^2$ ) for screen openings  $1/2$  square inch ( $3.23 \text{ cm}^2$ ) or less in area, and shall not be less than No. 12 AWG ( $3.3 \text{ mm}^2$ ) for larger screen openings.

\*Added 6.7.1 effective December 17, 1997\*

6.7.2 Perforated sheet steel and sheet steel used for expanded metal mesh shall not be less than 0.042 inch (1.07 mm) thick – 0.045 inch (1.14 mm) if zinc coated – for mesh openings or perforations  $1/2$  square inch ( $3.23 \text{ cm}^2$ ) or less in area and shall not be less than 0.080 inch (2.03 mm) thick – 0.084 inch (2.13 mm) if zinc coated – for larger openings.

*Exception: Expanded metal mesh that complies with the requirements in 6.7.3 may be used.*

\*Added 6.7.2 effective December 17, 1997\*

6.7.3 In a small device where the indentation of a guard or enclosure will not alter the clearance between uninsulated, moveable, current-carrying parts and grounded metal so as to adversely affect performance or reduce spacings below the minimum values specified in Table 22.1, 0.020 inch (0.51 mm) expanded metal mesh – 0.023 inch (0.58 mm) if zinc-coated – may be used, if:

- a) The exposed mesh on any one side or surface of the device so protected has an area of not more than 72 square inches (464.5 cm<sup>2</sup>) and has no dimension greater than 12 inches (305 mm), or
- b) The width of an opening so protected is not greater than 3-1/2 inches (88.9 mm).

\*Added 6.7.3 effective December 17, 1997\*

## 6.8 Conduit openings

6.8.1 If threads for the connection of conduit are tapped all the way through a hole in an enclosure wall, or if an equivalent construction is used, there shall not be less than 3 threads in the metal, and the construction of the control shall be such that a conduit bushing can be attached as intended.

\*Added 6.8.1 effective December 17, 1997\*

6.8.2 If threads for the connection of conduit are not tapped all the way through a hole in an enclosure wall, conduit hub, or the like, there shall not be less than 3-1/2 threads in the metal and there shall be a smooth, rounded inlet hole for the conductors that affords protection to the conductors equivalent to that provided by a standard conduit bushing and that has an internal diameter approximately the same as that of the corresponding trade size of rigid conduit.

\*Added 6.8.2 effective December 17, 1997\*

6.8.3 In an enclosure threaded for support by rigid conduit, at least 5 full threads shall be provided for engaging the conduit.

\*Added 6.8.3 effective December 17, 1997\*

## 7 Rainproof Enclosures

7.1 A rainproof enclosure shall be so constructed, protected, or treated as to keep a simulated beating rain as described in 31.1 and 31.2 from accumulating at a level higher than the lowest live part within the enclosure. The enclosure shall be provided with external means for mounting, except that internal means for mounting may be employed if constructed so that water will not enter the enclosure. Hinges and other attachments shall be resistant to corrosion. Metal shall not be used in any combinations that result in galvanic action that adversely affect any part of the device.

7.2 An opening for conduit in a raintight enclosure, other than in the bottom of the enclosure, shall be threaded.

\*Added 7.2 effective December 17, 1997\*

7.3 An opening for conduit in a rainproof enclosure shall be threaded unless located wholly below the lowest terminal lug or other live part within the enclosure. There shall be provision for drainage of the enclosure if a knockout or unthreaded hole is provided other than in the bottom.

\*Revised 7.3 effective December 17, 1997\*

7.4 A rainproof sheet steel enclosure shall be protected against corrosion by one of the following coatings:

a) Hot-dipped mill galvanized sheet steel conforming with the coating Designation G90 in Table I of the Specification for Steel Sheet, Zinc-Coated (Galvanized) or Zinc-Iron Alloy-Coated (Galvannealed) by the Hot Dip Process, ASTM A653/A653M-94, with not less than 40 percent of the zinc on any side, based on the minimum single spot test requirement in this ASTM designation. The weight of the zinc coating may be determined by any acceptable method; however, in case of question the weight of coating shall be established in accordance with the test method of ASTM Designation A90-69.

b) A zinc coating, other than that provided on hot-dipped mill galvanized sheet steel, uniformly applied to an average thickness of not less than 0.00061 inch (0.015 mm) on each surface with a minimum thickness of 0.00054 inch (0.014 mm). The thickness of the coating shall be established as indicated in Metallic Coating Thickness Test, Section 34. An annealed coating shall comply with 7.6.

c) A zinc coating conforming with subitem 1 or 2 and with one coat of an organic finish of the epoxy or alkyd-resin type or other outdoor paint on both surfaces. The acceptability of the paint may be determined by consideration of its composition or by corrosion tests if these are considered necessary.

1) Hot-dipped mill galvanized sheet steel conforming with the coating designation G60 or A60 in Table I of the Specification for Steel Sheet, Zinc-Coated (Galvanized) or Zinc-Iron Alloy-Coated (Galvannealed) by the Hot Dip Process, ASTM A653/A653M-94, with not less than 40 percent of the zinc on any side, based on the minimum single spot test requirement in this ASTM Designation. The weight of zinc coating may be determined by any acceptable methods; however, in case of question the weight of coating shall be established in accordance with the test method of ASTM Designation A90-69. An A60 (alloyed) coating shall also comply with 7.6.

2) A zinc coating, other than that provided on hot-dipped mill galvanized sheet steel, uniformly applied to an average thickness of not less than 0.00041 inch (0.010 mm) on each surface with a minimum thickness of 0.00034 inch (0.009 mm) the thickness of the coating shall be established as indicated in Metallic Coating Thickness Test, Section 34. An annealed coating shall also comply with 7.6.

d) A cadmium coating not less than 0.0010 inch (0.025 mm) thick on both surfaces. The thickness of coating shall be established as indicated in Metallic Coating Thickness Test, Section 34.

e) A cadmium coating not less than 0.00075 inch (0.019 mm) thick on both surfaces with one coat of outdoor paint on both surfaces, or not less than 0.0005 inch (0.013 mm) thick on both surfaces with two coats of outdoor paint on both surfaces. The thickness of the cadmium coating shall be established as indicated in Metallic Coating Thickness Test, Section 34, and the paint shall be as described in item c).

\*7.4 revised April 10, 1996\*

7.5 Other finishes, including paints, special metallic finishes, and combinations of the two may be used when comparative tests with galvanized sheet steel (without annealing, wiping, or other surface treatment) conforming with 7.4 (a) indicate they provide equivalent protection. Among the factors that are taken into consideration when determining the acceptability of such coating systems are exposure to salt spray, moist carbon dioxide-sulfur dioxide-air mixtures, moist hydrogen sulfide-air mixtures, ultraviolet light and water.

\*7.5 revised April 10, 1996\*

7.6 A hot-dipped mill galvanized A60 (alloyed) coating or an annealed zinc coating that is bent or similarly formed after annealing and that is not otherwise required to be painted shall be painted in the bent or formed area if the bending or forming process damages the zinc coating.

7.7 If flaking or cracking of the zinc coating at the outside radius of the bent or formed section is visible at 25 power magnification, the zinc coating is considered damaged. Simple sheared or cut edges and punched holes are not considered to be formed, but extruded and rolled edges and holes are to conform with 7.6.

7.8 A gasket of an elastomeric or thermoplastic material or a composition gasket utilizing an elastomeric material employed to make an enclosure rainproof (see 7.1) shall be resistant to aging as determined by the accelerated-aging tests described either in 35.1 or in 35.2, whichever applies.

7.9 Adhesive cement if used to secure the gasket shall be resistant to aging as determined by the accelerated-aging test described in 35.3.

## 8 Mounting

### 8.1 General

8.1.1 Provision shall be made for securely mounting a permanently connected clock-operated switch in position. Bolts, screws, or other parts used for assembling the switch shall be independent of those used for securing component parts of the switch to the frame, base, or panel. If the assembly must be removed from the housing for installation, the switch shall be independent of the assembly.

8.1.2 A cord-connected switch shall not include means for permanent mounting. One or two keyhole slots for wall hanging may be provided if the hanging screws, nails, and the like, are not accessible for tightening, and if long nails, hooks, or screws for hanging will not be likely to touch internal wiring, the operating mechanism or live parts and will not result in spacing less those required in Table 22.1.

### 8.2 Plug-in devices

8.2.1 A clock-operated switch having attachment-plug blades for plug-in connection to a receptacle outlet rated 15 A, 125 V, and having the ANSI/NEMA WD6-1988 slot configuration shall have a mass of 28 oz (0.79 kg) or less. The moment, center of gravity, and dimensions shall not exceed the limits specified in 8.2.2.

8.2.2 The moment, center of gravity, and dimensions of a clock-operated switch, see Figure 8.1, shall comply with each of the following:

- a) The quotient of  $WY/Z$  shall not exceed 48 oz (1.36 kg).
- b) The quotient of  $WY/S$  shall not exceed 48 oz.
- c) The product of  $WX$  shall not exceed 80 oz-inch (0.56 N•m).
- d) The dimension  $Z_3$  shall not exceed 3-1/4 inches (82.6 mm).
- e) The dimensions  $S_1$ ,  $S_2$ ,  $Z_1$ , and  $Z_2$  shall not exceed 5 inches (127 mm).

\*8.2.2 revised April 10, 1996\*



**Figure 8.1**  
**Plug-in clock-operated limits of dimensions**

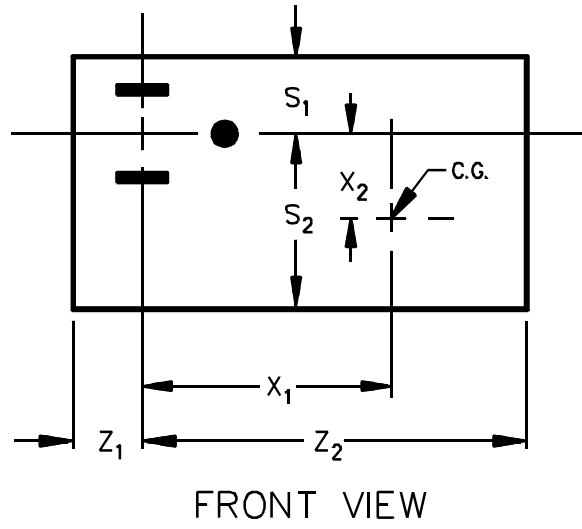

FRONT VIEW

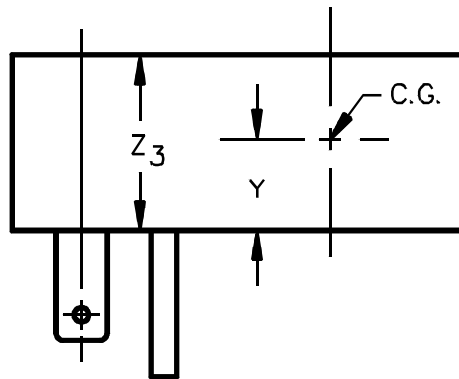

SIDE VIEW

C.G. = Center of Gravity

8.2.3 Definitions for the symbols used in 8.2.2 are as follows:

W is the weight of the switch in ounces (kg),  
Y is in inches (mm),  
Z is the smaller of  $Z_1$  or  $Z_2$  in inches (mm),  
S is the smaller of  $S_1$  or  $S_2$  in inches (mm), and  
X is the larger of  $X_1$  or  $X_2$  in inches (mm).

## 9 Assembly

9.1 A switch, a lampholder, a motor-attachment cap, or similar component shall be mounted securely and, except as noted in 9.2 and 9.3, shall be resistant to turning. See 9.4.

9.2 The requirement that a switch be kept from turning may be waived if all four of the following conditions are met:

- a) The switch is of a plunger or other type that does not tend to rotate when operated (a toggle switch is considered to be subject to forces that tend to turn the switch during ordinary operation of the switch).
- b) The means of mounting the switch make it unlikely that operation of the switch will loosen it,
- c) The spacings are not to be reduced below the minimum acceptable values if the switch rotates, and
- d) Operation of the switch is by mechanical means rather than direct contact by persons.

9.3 A lampholder of a type in which the lamp cannot be replaced – such as a neon pilot or indicator light in which the lamp is sealed in a nonremovable jewel – need not be kept from turning if rotation cannot reduce spacings below the minimum acceptable values.

9.4 The means for resisting turning mentioned in 9.1 and 9.5 is to consist of more than friction between surfaces – for example, a lock washer, properly applied, is acceptable as a means to resist turning of a small stem-mounted switch or other device having a single-hole mounting means.

9.5 Live parts shall be so secured to the base or mounting surface that they will resist turning or shifting in position if such motion may result in a reduction of spacings below the minimum acceptable values indicated in Table 22.1.

## 10 Operating Mechanism

10.1 The assembly of the switch shall be such that it will not be affected adversely by the vibration of operation.

10.2 A wire-binding screw or nut shall be provided with a lock washer under the head of the screw, or under the nut, to keep it from loosening due to vibration if such loosening might permit shifting of parts, thereby reducing spacings, or otherwise result in a risk of fire, electric shock, or injury to persons.

10.3 A permanently connected clock-operated switch or one with a polarized or grounded attachment plug shall not disconnect the grounded conductor of a circuit.

*Exception No. 1: A switch that simultaneously disconnects all conductors of the circuit need not comply with this requirement.*

*Exception No. 2: A switch that is so arranged that the grounded conductor cannot be disconnected until all the ungrounded conductors of the circuit have been disconnected need not comply with this requirement.*

10.4 Operation of a permanently connected clock-operated switch, with a marked off position, that disconnects any conductor of an output circuit shall disconnect all ungrounded conductors of the same circuit simultaneously.

10.5 A cord-connected switch that has a polarized or grounded attachment plug shall comply with 10.4.

10.6 In determining compliance with 10.4 and 10.5, overcurrent and other protective devices are considered to provide operation. In addition, all poles of a multiple switching device are considered to operate simultaneously.

## **11 Corrosion Protection**

11.1 Iron and steel parts shall be protected against corrosion by enameling or other equivalent means, if the corrosion of such parts is likely to result in a risk of fire, electric shock, or injury to persons.

11.2 In determining compliance with 11.1, phosphate treatment with an oil or wax coating is acceptable as corrosion protection for magnets and armatures. Oil treatment is acceptable for steel springs. Stainless steel is acceptable without additional protection if properly polished or treated when necessary.

## **12 Insulating Material**

12.1 A base for the support of live parts shall be of strong, moisture-resistant, insulating material. A material other than slate, porcelain, phenolic or cold-molded composition, or one that is acceptable for the support of live parts shall be investigated under conditions of actual service to determine if it has the necessary electrical and mechanical properties and is otherwise acceptable for the particular application. The base shall be so constructed that, considering the material used, it will withstand the most severe conditions likely to be met in service.

12.2 Insulating material, including barriers between parts of opposite polarity and material that may be subject to the influence of the arc formed by the separation of switching contacts, shall be acceptable for the particular application.

12.3 Vulcanized fiber may be used for insulating bushings, washers, separators, and barriers, but not as the sole support for uninsulated live parts of other than low-voltage circuits.

12.4 Sleeving, tape, and tubing on wires that involve a risk of fire or electric shock shall be rated for the temperature and voltage involved. Tape shall be flame-retardant. Sleeving and tubing shall have a flame-retardant rating VW-1. Sleeving, tape, and tubing need not be flame-retardant if employed on wiring that does not involve a risk of fire or electric shock and that is separated from wiring and other parts involving a risk of fire or electric shock. Combinations of insulated wire covered with sleeving, tape, or tubing where either the wire, sleeving, tape, or tubing is not classified as flame-retardant may be subjected to the flame test outlined for VW-1 wire to determine if the combination may be classified as VW-1.

### 13 Field Connections

13.1 In 14.1.1 – 14.1.3 and 14.3.2 – 14.3.7, and particularly where wiring terminals are mentioned in connection with permanently connected equipment, field connections are considered to be those that are made in the field when a device is installed.

### 14 Supply Connections

#### 14.1 Permanently connected devices

14.1.1 A switch intended for permanent connection to the supply source shall be provided with wiring terminals or leads for the connection of conductors of at least the size required by the National Electrical Code, ANSI/NFPA 70 corresponding to the rating of the device.

14.1.2 A lead that is intended to be spliced in the field to a circuit conductor shall not be smaller in size than No. 18 AWG.

14.1.3 A permanently connected switch shall have provisions for the connection of one of the wiring systems that, in accordance with the National Electrical Code, ANSI/NFPA 70, would be acceptable.

#### 14.2 Connections for wiring systems

14.2.1 A tapped hole for the attachment of threaded rigid conduit shall be provided with:

- a) An end-stop, or shall be so located that a standard bushing may be attached to the end of the conduit,
- b) A tapered thread in rainproof equipment if not provided with an end stop, and
- c) At least three full threads when tapped all the way through the wall of an enclosure, or with at least 3-1/2 full threads and a smooth, well-rounded inlet hole having a diameter approximately the same as the internal diameter of a standard bushing to provide protection for the conductors equivalent to that provided by such a bushing.

14.2.2 A knockout in a sheet-metal enclosure shall be secured but shall be capable of being removed without undue deformation of the enclosure. See Knockout Secureness Test, Section 39.

14.2.3 A knockout shall be provided with a flat surrounding surface for proper seating of a conduit bushing, and shall be so located that installation of a bushing at any knockout likely to be used during installation will not result in spacings between uninsulated live parts and the bushing of less than the minimum requirements in Spacings, Section 22.

14.2.4 For an enclosure not provided with conduit openings or knockouts, spacings not less than the minimum required in Spacings, Section 22 shall be provided between uninsulated live parts and a conduit bushing installed at any location likely to be used during installation. If it is necessary to limit the location of openings, a permanent marking of the enclosure, a template, or a full-scale drawing shall be furnished with the device.

14.2.5 In measuring a spacing between an uninsulated live part and a bushing installed in the knockout referred to in 14.2.3 and 14.2.4, it is to be assumed that a bushing having the dimensions indicated in Table 14.1 is in place, in conjunction with a single locknut installed on the outside of the enclosure.

**Table 14.1**  
**Bushing dimensions**

Trade size of conduit in inches	Overall diameter in inches (mm)	Height in inches (mm)
1/2	1 ( 25.4)	3/8 ( 9.5)
3/4	1-15/64 ( 31.4)	27/64 (10.7)
1	1-19/32 ( 40.5)	33/64 (13.1)
1-1/4	1-15/16 ( 49.2)	9/16 (14.3)
1-1/2	2-13/64 ( 56.0)	19/32 (15.1)
2	2-45/64 ( 68.7)	5/8 (15.9)
2-1/2	3-7/32 ( 81.8)	3/4 (19.1)
3	3-7/8 ( 98.4)	13/16 (20.6)
3-1/2	4-7/16 (112.7)	15/16 (23.8)
4	4-31/32 (126.2)	1 (25.4)
4-1/2	5-35/64 (140.9)	1-1/16 (27.0)
5	6-7/32 (158.0)	1-3/16 (30.2)
6	7-7/32 (183.4)	1-1/4 (31.8)

14.2.6 Clamps and fasteners for the attachment of conduit, electrical metallic tubing, armored cable, nonmetallic flexible tubing, nonmetallic-sheathed cable, service cable, and the like, that are supplied as a part of an enclosure shall comply with the Standard for Fittings for Conduit and Outlet Boxes, UL 514B.

### 14.3 Terminals

14.3.1 To determine the acceptability of field-wiring terminals covered in 14.3.2 – 14.3.7, stranded wire is to be used for No. 8 AWG and larger conductors.

14.3.2 Connection of conductors to terminal parts shall provide good connection without damaging the conductors and shall be made by means of pressure connectors (including setscrew type), solder lugs or splices to flexible leads, except that No. 10 AWG or smaller conductors may be connected by means of wire-binding screws or studs and nuts having upturned lugs or the equivalent. Terminals for more than one conductor and terminals used to connect aluminum wire shall be of a type acceptable for the purpose.

14.3.3 A wire-binding screw to which field-wiring connections are made shall not be smaller than No. 8, except that a No. 6 screw may be used for a terminal to which one No. 14 AWG wire would be connected.

14.3.4 A terminal plate tapped for a wire-binding screw shall be of metal not less than 0.030 inch (0.76 mm) thick for a No. 14 AWG or smaller wire, and not less than 0.050 inch (1.27 mm) thick for a wire larger than No. 14 AWG. There shall not be less than two full threads in the metal, which may be extruded if necessary to provide the threads.

14.3.5 A wire-binding screw shall thread into metal.

14.3.6 A switch intended for permanent connection to a grounded conductor of a power-supply circuit shall have one terminal or lead identified for the connection of such conductor.

14.3.7 A terminal intended for the connection of the grounded power-supply conductor shall be of, or plated with, metal that is substantially white in color, and that terminal shall be readily distinguishable from the other terminal or terminals; or proper identification of that terminal shall be clearly shown in some other manner (such as on an attached wiring diagram). The surface of a lead intended for the connection of a grounded power-supply conductor shall be white or natural grey, and shall be readily distinguishable from the other lead or leads.

## **15 Cord-Connected Devices**

### **15.1 Cords and plugs**

15.1.1 A cord-connected switch shall be provided with a flexible cord and an attachment plug for connection to the supply circuit.

15.1.2 The flexible cord shall be of a type rated for use at a voltage not less than the rated voltage of the device, and shall have an ampacity as given in the National Electrical Code, ANSI/NFPA 70, not less than the current rating of the device.

15.1.3 The flexible cord is to be of jacketed construction not lighter than Type SJ; except that a device having a maximum rating of 2000 VA, 1 hp, or 300 V, may be provided with a cord not lighter than Type SP-2.

15.1.4 The flexible cord shall have a minimum length of 18 inch (457 mm) and shall not exceed 10 ft (3.05 m).

15.1.5 The attachment plug shall comply with the Standard for Attachment Plugs and Receptacles, UL 498. It shall be of the type intended for use:

- a) With a value of current equal to the rated current of the device, or equal to the value nearest to the rated current whichever is smaller, and
- b) At a voltage equal to the rated voltage of the device.

### **15.2 Polarization**

15.2.1 If the supply cord of a cord-connected switch has a polarized or grounded attachment plug, and a lampholder of the screw shell type is connected to the line voltage circuit, the screw shell shall be connected to the grounded conductor of the circuit.

15.2.2 If either contact of a fuseholder is accessible while a fuse is being added or removed, that contact shall be connected toward the load.

### **15.3 Strain relief**

15.3.1 Strain relief shall be provided so that a mechanical strain on a flexible supply cord will not be transmitted to terminals, splices, or interior wiring, see Strain Relief Test, Section 37.

15.3.2 If a knot serves as strain relief in an attached flexible cord, any surface with which the knot may come in contact shall be free from projections, sharp edges, burrs, fins, and the like, that may cause abrasion of the insulation on the conductors.

15.3.3 Means shall be provided to keep the flexible cord from being pushed into the enclosure of the device through the cord-entry hole if such displacement is likely to subject the cord to mechanical injury or to expose the cord to a temperature higher than that for which it is rated, or if it is likely to reduce spacings (such as to a metal strain-relief clamp) below the minimum acceptable values.

#### **15.4 Bushings**

15.4.1 At a point where a flexible cord passes or is intended to pass through an opening in a wall, barrier, or enclosing case, there shall be a bushing or the equivalent that shall be secured in place, and shall have a smoothly rounded surface against which the cord may bear. If a nonjacketed cord is employed, an insulating bushing shall be provided.

15.4.2 If the cord hole is in wood, porcelain, phenolic composition, or other nonconducting material, a smoothly rounded surface is considered to be the equivalent of a bushing.

15.4.3 Ceramic materials and some molded compositions are acceptable generally for insulating bushings; but separate bushings of wood or so-called hot-molded shellac and tar compositions are not acceptable.

15.4.4 A fiber bushing shall not be less than 3/64 inch (1.2 mm) thick shall be so formed and secured in place that it will not be affected adversely by conditions of ordinary moisture, and shall not be employed where it will be subjected to a temperature higher than 90EC (194EF) under operating conditions.

#### **16 Grounding**

16.1 A switch intended to be permanently connected to the supply source shall have a terminal or lead for connection to the equipment-grounding conductor of the system.

16.2 A cord-connected switch intended for use on circuits involving a potential of more than 150 V shall incorporate an equipment-grounding conductor in the flexible cord and a grounding type attachment plug.

16.3 The equipment-grounding terminal or lead-grounding point shall be connected to the frame or enclosure by a positive means, such as by a bolted or screw connection. The grounding connection shall penetrate nonconductive coatings, such as paint or vitreous enamel. The grounding point shall be so located that it is unlikely that the grounding means will be removed during servicing not involving the ground connection.

16.4 A wire-binding screw intended for the connection of an equipment-grounding conductor shall have a green-colored head that is hexagonal shaped, slotted, or both. A pressure wire connector intended for connection of such a conductor shall be plainly identified such as by being marked "G," "GR," "GND," "Ground," "Grounding," or the like, or by a marking on a wiring diagram provided on the device. The wire-binding screw or pressure wire connector shall be so located that it is unlikely to be removed during servicing of the unit not involving the grounding connection.

16.5 The surface of an insulated lead intended solely for the connection of an equipment-grounding conductor shall be green or shall be green with or without one or more yellow stripes, and no other lead shall be so identified.

16.6 A terminal for connection of an equipment-grounding conductor shall be capable of securing a conductor of the size acceptable for the particular application, in accordance with the National Electrical Code, ANSI/NFPA 70.

16.7 A soldering lug, a push-in (screwless) connector, or a quick-connect or similar friction-fit connector shall not be used for the grounding terminal.

16.8 When provided, the grounding conductor of the power-supply cord of a cord-connected switch shall be attached to the grounding blade of an attachment plug of the grounding type, and shall be connected within the confines of the frame or enclosure by means of a screw not likely to be removed during servicing other than servicing the power-supply cord. The grounding conductor shall be arranged so that an external pull on the power-supply cord will not transmit strain to the grounding connection on the frame or enclosure before the line-voltage connections are broken.

16.9 The circuitry of a switch shall be arranged so that the equipment-grounding connection or conductor, the enclosure, the frame, the component mounting panel, and the earth ground do not carry current except in the instance of an electrical fault.

## 17 Receptacles

17.1 A 15- or 20-A general-use attachment-plug receptacle in a switch provided with a means for grounding – a permanently wired or a cord-connected device with a grounding conductor in the cord – shall be of the grounding type. The grounding contact of the receptacle shall be connected to dead metal that will be grounded when the switch is in use.

17.2 If the integral blades of a plug-in switch are:

- a) Not polarized, the receptacle(s) provided as part of the plug-in switch shall be of the nonpolarized type,
- b) Polarized, the receptacle(s) provided shall be of the polarized type, and
- c) Of the grounding type, the receptacle(s) provided shall be of the grounding type.

17.3 If the power-supply cord of a cord-connected switch has:

- a) A polarized attachment plug, the receptacle(s) provided as part of the switch shall be of the polarized type,
- b) A nonpolarized attachment plug, the receptacle(s) provided shall be nonpolarized, and
- c) A grounding type attachment plug, the receptacle(s) shall be of the grounding type.

17.4 If a switch includes one or more attachment-plug receptacle(s) intended for general use, and if the overcurrent protection of the branch circuit to which the appliance will properly be connected in accordance with the National Electrical Code, ANSI/NFPA 70, exceeds that acceptable for the receptacle or receptacles, each receptacle circuit shall have overcurrent protection of not more than 20 A provided as a part of the switch.

17.5 If the face of a receptacle is less than 5/8 inch (15.9 mm) wide or less than 7/8 inch (22.2 mm) long, the face of the receptacle shall not project more than 3/16 inch (4.8 mm) from the part of the mounting surface that is within a rectangular 5/8 inch (15.9 mm) wide and 7/8 inch (22.2 mm) long symmetrically located about the receptacle contacts; and if the mounting surface is conductive, the face of the receptacle shall not project less than 3/32 inch (2.4 mm) from that part of the mounting surface.



17.6 The area surrounding a switch-controlled attachment-plug receptacle shall be free of any projection that would stop full insertion of the blades of a circular attachment plug having a face diameter of 1-5/16 inch (33.3 mm) and a rectangular plug having a face of 1-1/2 by 5/8 inch (38.1 by 15.9 mm), unless the projections are such that the blades of the attachment plug are stopped from being inserted to make electrical contact with the female contacts of the receptacle.

## 18 Bonding of Internal Parts

### 18.1 General

18.1.1 On a switch that is grounded, an accessory dead metal part that is likely to become energized through electrical fault shall be bonded to the point of connection of the equipment-grounding means.

*Exception No. 1: Metal parts, such as an adhesive-attached metal-foil marking, screws, handles, and the like, need not comply with this requirement provided they are:*

- a) Located on the outside of enclosures or cabinets and isolated from electrical components or wiring by grounded metal parts so that they are not likely to become energized or*
- b) Separated from wiring and spaced from uninsulated live parts as if they were grounded parts.*

*Exception No. 2: Also exempted from this requirement are:*

- a) Small internal assembly screws, or other small fasteners such as rivets, and*
- b) Relay, contactor magnets, and armatures.*

*Exception No. 3: A metal panel or cover employed need not comply with this requirement, provided:*

- a) The panel or cover is insulated from electrical components and wiring by an insulating barrier of vulcanized fiber, varnished cloth, phenolic composition, or other moisture-resistant material not less than 1/32 inch (0.8 mm) thick that is secured in place, or*
- b) The panel or cover does not enclose uninsulated live parts, and that wiring is positively separated from the panel or cover so that it is not likely to become energized, or*
- c) The panel or cover is separated from live parts and wiring by grounded or bonded interposing metal, such that the interposing metal would be subject to the electrical fault before the panel or cover involved.*

18.1.2 A grounded switch shall have uninsulated metal parts of cabinets, electrical enclosures and covers, and mechanism assemblies bonded for grounding if they may be contacted by the user while adjusting controls, including infrequent or seasonal time adjustment.

18.1.3 An integral connection for bonding internal parts to the enclosure for grounding – but not for a field-installed grounding conductor or for the grounding wire in a supply cord – may employ a quick-connect terminal of the dimensions shown in column 1 of Table 18.1, provided the connector is not likely to be displaced, and provided the component is limited to use on a circuit having a branch circuit protective device rated not higher than indicated in column 2 of Table 18.1.

**Table 18.1**  
**Dimensions of quick-connect terminals**  
**for bonding internal parts to the**  
**enclosure and associated maximum**  
**branch-circuit overcurrent protection**

Nominal dimensions of terminal	Maximum branch- circuit overcurrent protection
0.020 by 0.187 by 1/4 inch (0.5 by 4.8 by 6.4 mm)	20 amperes or less
0.032 by 0.187 by 1/4 inch (0.8 by 4.8 by 6.4 mm)	20 amperes or less
0.032 by 0.205 by 1/4 inch (0.8 by 5.3 by 6.4 mm)	20 amperes or less
0.032 by 1/4 by 5/16 inch (0.8 by 6.4 by 7.9 mm)	20 amperes or less

18.1.4 Uninsulated live parts and wiring shall be kept away from moving parts, such as relay and contactor magnets and armatures, by clamping, routing, or equivalent means that will provide permanent separation.

## 18.2 Construction and connection

18.2.1 The bonding shall be by a positive means such as by clamping, riveting, bolted or screwed connection. The bonding connection shall effectively penetrate nonconductive coatings, such as paint or vitreous enamel. See Grounding Resistance Test, Section 36.

## 19 Current-Carrying Parts

19.1 A current-carrying part shall be of silver, copper, a copper alloy, stainless steel or other metal acceptable for the particular application.

19.2 Ordinary iron or steel, if provided with a corrosion-resistant coating, may be used for a current-carrying part if permitted in accordance with 3.1 but the use of ordinary iron or steel for current-carrying parts elsewhere in the device is not acceptable. The foregoing does not apply to stainless steel.

19.3 Uninsulated live parts, including terminals, shall be secured to their supporting surfaces by methods other than friction between surfaces – a lock washer properly applied is generally acceptable – so that they will be kept from turning or shifting in position if such motion may result in reduction of spacings to less than those required in Table 22.1. The security of contact assemblies shall be such as to provide the continued alignment of contacts.

**20 Internal Wiring**

20.1 The insulation on wires that involve the risk of fire or electric shock shall be rated for the voltage involved and the temperature attained under any conditions of actual use, and shall have a flame retardant rating VW-1. The insulation on wires that do not involve a risk of fire or electric shock need not have a flame-retardant rating if the wires are segregated (for example, by routing) from wiring involving a risk of fire or electric shock.

20.2 Appliance wiring material of one or more of the types indicated in Table 20.1 may be used for internal wiring when considered with respect to the requirements in 20.1.

**Table 20.1  
Appliance-wiring material**

Type of insulation	Minimum acceptable thickness of insulation	
	600-V applications	300-V applications
Thermoplastic	0.028 inch (0.71 mm)	0.028 inch <sup>a</sup> (0.71 mm) <sup>a</sup>
Rubber	0.028 inch (0.71 mm) plus an impregnated-braid cover	0.013 inch (0.33 mm) plus an impregnated-braid cover, or 0.028 inch (0.71 mm) without a braid cover
Neoprene	0.041 inch (1.04 mm)	0.013 inch (0.33 mm) plus an impregnated-braid cover, or 0.028 inch (0.71 mm) without a braid cover
Silicone rubber	0.028 inch (0.71 mm) plus an impregnated-braid cover 0.028 <sub>b</sub> inch (0.71 mm) without a braid cover	0.013 inch (0.33 mm) plus an impregnated-braid cover, or 0.028 <sub>b</sub> inch (0.71 mm) without a braid cover
<sup>a</sup> May be 0.013 inch (0.33 mm) provided such leads make no more than casual contact with parts of opposite polarity and with grounded parts. <sup>b</sup> Only if routed away from live parts of opposite polarity and protected from mechanical damage both during installation of field wiring and while in operation, unless material has adequate resistance to mechanical damage.		

20.3 Appliance wiring material having lesser thicknesses of insulation than those indicated in Table 20.1 may be used for a particular application, provided the insulation when considered with respect to temperature and voltage and condition of service, is equivalent to one of those given in Table 20.1.

20.4 The internal wiring and connections between parts of a clock-operated switch shall be protected or enclosed.

20.5 With reference to exposure of internal wiring through an opening in the enclosure of a clock-operated switch, the protection of the wiring required by 20.4 is considered to exist if, when considered as though it were a film-coated wire, the wiring would be acceptable according to 6.1.6. Internal wiring not so protected may be accepted if it is so secured within the enclosure that it is unlikely to be subjected to stress or mechanical damage.

20.6 Wireways shall be smooth and entirely free from sharp edges, burrs, fins, moving parts, and the like that may cause abrasion of the insulation on conductors.

20.7 A hole in a sheet-metal wall through which insulated wire pass and on the edges of which they may bear, shall be provided with a smoothly rounded bushing or shall have a smooth, well-rounded surface upon which the wires may bear, to reduce the risk of abrasion of the insulation.

20.8 A bare conductor, including pigtailed and coil leads, shall be so supported that the spacings required in Table 22.1 will be maintained unless covered by insulating sleeving or tubing.

20.9 Where failure of electrical connections will involve a risk of fire or electric shock, they shall be soldered, welded, or otherwise securely connected. A soldered joint shall be mechanically secure before soldering.

20.10 A lead is considered to be mechanically secure when one or more of the following is provided:

- a) At least one full wrap around a terminal.
- b) At least one right angle bend when passed through an eyelet or opening.
- c) Twisted with other conductors.

20.11 A splice shall be provided with insulation equivalent to that of the wires involved.

## 21 Coil Windings

21.1 Coil windings of motors, relays, transformers, and the like, shall be such as to resist the absorption of moisture. This may be accomplished by impregnating, dipping, or brushing with varnish, or by other equivalent means.

21.2 With reference to the requirements in 21.1, film-coated wire is not required to be additionally treated to resist the absorption of moisture, but fiber liners, coarse coil wrap, and similar moisture-absorptive materials are to be provided with impregnation or otherwise treated to resist moisture absorption. See Humidity Test, Section 40.

## 22 Spacings

22.1 A live screw head or nut on the underside of an insulating base shall be secured so that they will not loosen and shall be insulated or spaced from the mounting surface. This may be accomplished by:

- a) Countersinking such parts not less than 1/8 inch (3.2 mm) in the clear and then covering them with a waterproof, insulating sealing compound that does not melt at a temperature 15EC (27EF) higher than its normal operating temperature in the device, and not less than 65EC (149EF) in any case, or
- b) Securing such parts and insulating them from the mounting surface by means of a barrier or the equivalent, or by means of through-air or over-surface spacings as required in Table 22.1.

22.2 The inherent spacings of a component supplied as part of a switch, such as a snap switch, lampholder, motor, or clock motor are judged under the requirements for that component. The spacings from such a component to another component and to the enclosure, and the spacings at wiring terminals are given in Table 22.1.

**Table 22.1**  
**Minimum spacings in inches (mm)**

Potential involved in volts	Spacing	Minimum rating of					
		600 V Unlimited volt-amperes A			600 V (See 22.6 and 22.7) B		300 V 2000 V A C
		51 – 150	151 – 300	301 – 600	51 – 300	301 – 600	51 – 300
Between any uninsulated live part and; (1) uninsulated live parts at different potentials (2) uninsulated grounded dead metal parts other than the enclosure, or (3) exposed dead metal parts	Through air or oil	1/8 <sup>a</sup> (3.2)	1/4 (6.4)	3/8 (9.5)	1/16 <sup>a</sup> (1.6) <sup>a</sup>	3/16 <sup>a</sup> (4.8) <sup>a</sup>	1/16 <sup>a</sup> (1.6) <sup>a</sup>
Between any uninsulated live part and the walls of a metal enclosure, including fittings <sup>a</sup> for conduit or armored cable	Over Surface	1/4 (6.4)	3/8 (9.5)	1/2 (12.7)	1/8 <sup>a</sup> (3.2) <sup>a</sup>	3/8 (9.5)	1/16 <sup>a,c</sup> (1.6) <sup>a,c</sup>
	Shortest distance	1/2 (12.7)	1/2 (12.7)	1/2 (12.7)	1/4 (6.4)	1/2 (12.7)	1/4 (6.4)

<sup>a</sup> The spacing between wiring terminals at different potentials and between a wiring terminals at different potentials and between a wiring terminal and a grounded or an exposed dead metal part shall be not less than 1/4 inch if short-circuiting or grounding of such terminals may result form projecting strands of wire.

<sup>b</sup> For the purpose of this requirement, a metal piece attached to the enclosure is considered ot be a part of the enclosure if deformation of the enclosure is likely to reduce the spacings between the metal piece and uninsulated live part.

<sup>c</sup> For a device with a 1/16 inch over-surface spacing, all electrical parts of the device are required to be subjected to regular production dielectric voltage-withstand tests. The applied test potential shall be specified in 32.1–32.6, with and additional 20–percent voltage applied if the test time is 1 second instead of 1 minute.

22.3 The spacing at a field-wiring terminal is to be measured using wire of the appropriate size (for the rating) connected to the terminal as in actual service. The connected wire – if the terminal will accommodate it properly or the device is not marked to restrict its use – is to be the next larger size than would be required.

22.4 The spacings in switches shall not be less than those indicated in Table 22.1. Greater spacings may be required if the enclosure, because of its size, shape, or the material used, is not considered to be rigid enough to warrant the minimum spacings.

22.5 In a circuit involving a potential of not more than 50 V:

- a) The insulation and clearances between the low-potential circuit and any high-potential circuit shall be in accordance with the requirements that are applicable to the high-potential circuit,
- b) Spacings are not specified for low-voltage circuits (see 2.5) and

c) At other parts:

- 1) Spacings at field-wiring terminals shall be not less than 1/8 inch (3.2 mm) through air and 1/4 inch (6.4 mm) over surface.
- 2) Spacings elsewhere shall be not less than 1/16 inch (1.6 mm) through air or over surface.

22.6 The spacings indicated in column B of Table 22.1 are applicable also to horsepower-rated controllers, 1 hp or less, having supplementary current ratings – other than for control circuits – of not more than 15 A at 51 – 150 V, 10 A at 151 – 300 V, or 5 A at 301 – 600 V.

22.7 With regard to 22.6, the spacings applicable to a device of the type described apply also to that device when controlling more than one load provided the total load connected to the line at one time does not exceed 2 hp or have a current rating greater than 30 A at 51 – 150 V, 20 A at 151 – 300 V, or 10 A at 301 – 600 V.

22.8 An insulating barrier or liner used as the sole separation between uninsulated live parts and dead metal parts, including the enclosure, or between uninsulated live parts where there is a difference in potential shall be of material of a type that is acceptable for the mounting of uninsulated live parts and not less than 0.028 inch (0.71 mm) thick. Otherwise a barrier shall be used in conjunction with at least 1/32-inch (0.8-mm) air spacing.

*Exception: In a permanently connected switch, fiber not less than 0.028 inch (0.71 mm) thick may be used as the sole separation between the enclosure and an uninsulated metal part electrically connected to a grounded circuit conductor.*

22.9 An insulating barrier or liner that is used in addition to an air space in place of the required spacing through air shall not be less than 0.028 inch (0.71 mm) thick. If the barrier or liner is of fiber, the air space shall not be less than 1/32 inch (0.8 mm). If the barrier or liner is of other material of a type that is not acceptable for the support of uninsulated live parts, the air space provided shall be such that upon investigation, it is found to be acceptable for the particular application.

*Exception: A barrier or liner that is used in addition to not less than one-half the required spacing through air may be less than 0.028 inch (0.71 mm) but not less than 0.013 inch (0.33 mm) thick provided that the barrier or liner is of material of a type that is acceptable for the mounting of uninsulated live parts, of acceptable mechanical strength if exposed or otherwise likely to be subjected to mechanical damage, secured in place, and so located that it will not be affected adversely by operation of the equipment in service.*

22.10 Insulating material having a thickness less than that indicated in 22.8 and 22.9 may be used if, upon investigation, it is found to be acceptable for the particular application.

22.11 Film-coated wire is considered to be the same as an uninsulated live part in determining compliance of a device with the spacing requirements in Table 22.1.

22.12 Spacings on printed wiring boards may be less than indicated in 22.5 or in Table 22.1 provided an acceptable conformal coating or encapsulation is used.

22.13 The type and thickness of crossover-lead insulation and insulation under coil terminals secured to the coil winding may be less than that specified in 22.8 – 22.10, provided that for thicknesses less than 0.013 inch (0.33 mm), the coil is capable of withstanding a dielectric voltage-withstand test between coil-end leads after breaking the inner coil lead where it enters the layer. The application of the test potential is to be in accordance with 32.1 – 32.4.

### **23 Field-Wiring Space**

23.1 The space within the enclosure of a permanently connected switch shall provide ample room for the distribution of wires and cables required for the proper wiring of the device.

## **PERFORMANCE**

### **24 General**

24.1 A switch shall be subjected to the tests described in Sections 24 – 41. The order of tests, in as far as applicable, shall be: Leakage Current, Temperature, Overload, Endurance, and Dielectric Voltage-Withstand.

24.2 An alternating-current device having no frequency rating is to be tested on a circuit having a frequency of 60 Hz, except that a circuit having a lower frequency may be employed if agreeable to those concerned.

24.3 In a single-pole, double-throw switch, each position of the switch is to be tested as a single-pole, single-throw switch.

24.4 When selecting test potentials, devices with marked ratings in the ranges of 110 – 120, 220 – 240, 440 – 480, and 550 – 600 V are considered to be rated 120, 240, 480, and 600 V, respectively.

24.5 A permanently connected switch that has been tested for an ampere or horsepower rating, or both, may have a tungsten-filament-lamp load rating, even though it has not been tested for tungsten-filament-lamp load rating, provided the tungsten-filament-lamp load rating does not exceed one-tenth the value of the ampere rating or the full-load motor-running current, whichever is greater.

### **25 Leakage Current Test**

25.1 The leakage current (see 2.3) of a cord-connected and a plug-in switch rated for a nominal 120-V supply when tested in accordance with 25.2 – 25.6 shall not be more than 0.5 mA.

25.2 All accessible conductive surfaces are to be tested for leakage currents. The leakage currents from these surfaces are to be measured to the grounded supply conductor individually as well as collectively where simultaneously accessible, and from one surface to another where simultaneously accessible. Parts are to be considered exposed surfaces unless guarded by an enclosure considered acceptable for protection against a risk of electric shock as determined in 6.1.2 – 6.1.5. Surfaces are considered to be simultaneously accessible when they can be readily contacted by one or both hands of a person at the same time. These measurements do not apply to terminals operating at low voltage (42.4 V peak or 30 V rms).

25.3 If a conductive surface other than metal is used for the enclosure or part of the enclosure, the leakage current is to be measured using a metal foil with an area of 10 by 20 cm in contact with the surface. Where the surface is less than 10 by 20 cm, the metal foil is to be the same size as the surface. The metal foil is not to remain in place long enough to affect the temperature of the device.

25.4 The measurement circuit for leakage current is to be as shown in Figure 25.1. The measurement instrument is defined in items a) – d). The meter which is actually used for a measurement need only indicate the same numerical value for a particular measurement as would the defined instrument. The meter used need not have all the attributes of the defined instrument.

- a) The meter is to have an input impedance of 1500 ohms resistive shunted by a capacitance of 0.15  $\mu\text{F}$ .
- b) The meter is to indicate 1.11 times the average of the full-wave rectified composite waveform of voltage across the resistor or current through the resistor.
- c) Over a frequency range of 0 – 100 kHz, the measurement circuitry is to have a frequency response (ratio of indicated to actual value of current) that is equal to the ratio of the impedance of a 1500-ohm resistor shunted by a 0.15  $\mu\text{F}$  capacitor to 1500 ohms. At an indication of 0.5 mA, the measurement is to have an error or not more than 5 percent.
- d) Unless the meter is being used to measure leakage from one part of a device to another, the meter is to be connected between the accessible parts and the grounded supply conductor.

25.5 A switch is to be tested for leakage current in the as-received condition – that is, without prior energization except as may occur as part of the production-line testing. If the device is provided with a grounding pin or conductor, the grounding conductor is to be disconnected at the supply source attachment-plug receptacle (see Figure 25.1). The supply voltage is to be adjusted to 120 V. The test sequence, with reference to the measuring circuit, Figure 25.1, is to be as follows:

- a) With switch S1 open, the device is to be connected to the measuring circuit. Leakage current is to be measured using both positions of switch S2, and with the device switching contacts in all their normal operating positions.
- b) Switch S1 is then to be closed energizing the device and within a period of 5 seconds, the leakage current is to be measured using both positions of switch S2, and with the device switching contacts in all their normal operating positions.
- c) The leakage current is to be monitored until thermal stabilization. Both positions of switch S2 are to be used in determining this measurement. Thermal stabilization is considered to be obtained by operation as in the normal temperature test.



**Figure 25.1**  
**Leakage-current measurement circuit**

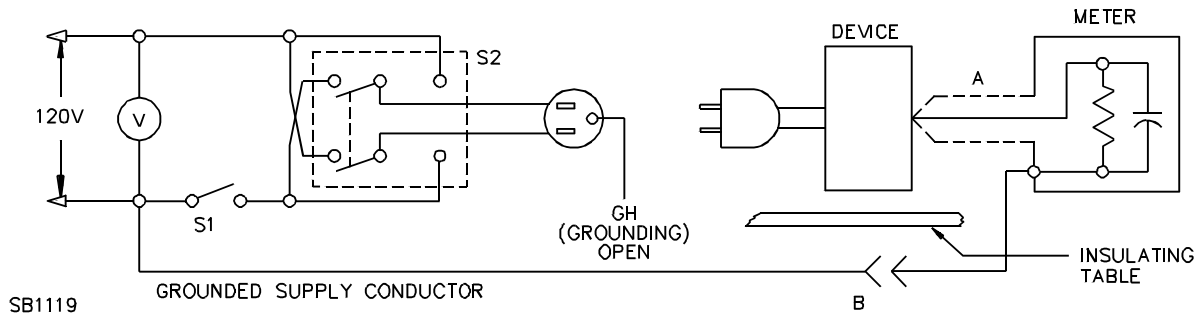

\*Figure 25.1 revised February 27, 1998\*

No Text on This Page

25.6 Typically, a representative device will be carried through the complete leakage current test program as covered by 25.5 without interruption for other tests. With the concurrence of those concerned, the leakage current tests may be interrupted for the purpose of conducting other nondestructive tests.

## 26 Temperature Test

26.1 When tested under the conditions described in 26.2 – 26.13, a switch shall not attain a temperature at any point high enough to constitute a risk of fire or to damage any materials employed in the device, nor show temperature rises at specific points greater than those indicated in Table 26.1.

26.2 A switch that does not have a quick-make-and-break-mechanism or if the blade or blades of the switch can be left in other than a full off or full contact position shall comply with the requirement in 26.1 with the mechanism in any on position in which it can be left.

26.3 A switch incorporating a volt-ampere rating shall be capable of carrying continuously a current of 10 A without showing temperature rises greater than those indicated in Table 26.1.

*Exception: A switch marked with a minimum as well as a maximum voltage rating along with a volt-ampere rating, or the equivalent, may be tested at its maximum current value.*

26.4 At a point on the surface of a coil where the temperature is affected by an external source of heat, the temperature rise measured by means of a thermocouple may be 15EC (27EF) more than the maximum indicated in items 9 and 12 of Table 26.1, and 5EC (9EF) more than the maximum indicated in items 10 and 13 of Table 26.1, provided the temperature rise of the coil, as measured by the resistance method, is not more than specified in Table 26.1.

26.5 All values for temperature rises given in Table 26.1 apply to devices intended for use with ambient temperatures normally prevailing in the occupiable spaces, which usually are not higher than 25EC (77EF) but may be as high as 40EC (104EF) occasionally and for brief periods. Tests of devices for service with such ambient temperatures may be conducted, without correction, with any ambient temperature in the range of 10 – 40EC (50 – 104EF).

26.6 If a switch is intended specifically for use with a prevailing ambient temperature constantly more than 25EC (77EF), the test of the device is to be made with such higher ambient temperature, and the allowable temperature rises specified in Table 26.1 are to be reduced by the amount of the difference between the higher ambient temperature and 25EC (77EF).

26.7 The temperature of the ambient air during the tests described in 26.5 and 26.6, is not to vary more than 2EC (3.6EF).

26.8 A low-potential source of supply may be utilized for conducting temperature tests on parts other than coils. Unless otherwise noted, the tests on all parts are to be made simultaneously, as the heating of one part may affect the heating of another part. A switch without an overall enclosure is to be tested with an enclosure of nominal size and of nonmetallic material to represent possible conditions of use within another device.

**Table 26.1**  
**Maximum temperature rises**

Materials and component parts		Degrees C	Degrees F
1.	Knife-switch blades and contact jaws	30	54
2.	Fuses	65	117
3.	Any point within a terminal box or wiring compartment of a permanently connected clock-operated switch in which field installed conductors are to be connected, including such conductors themselves, unless the clock-operated switch is marked in accordance with 43.7 <sup>a</sup>	35	63
4.	Class 90 insulation systems <sup>b</sup>		
	Thermocouple method	50	90
	Resistance method	60	108
5.	Varnished-cloth insulation	60	108
6.	Solid and built-up contacts, buses and connecting straps <sup>c</sup>	65	117
7.	Fiber employed as electrical insulation	65	117
8.	Wood or other combustible material	65	117
9.	Class A insulation systems on coil windings of d-c and universal motors: <sup>b</sup>		
	A. In open motors:	65	117
	Thermocouple method	75	135
	Resistance method		
	B. In totally enclosed motors:	70	126
	Thermocouple method	80	144
	Resistance method		
10.	Class A insulation systems on coil windings of a-c motors: <sup>b</sup>		
	A. In open motors (thermocouple or resistance method)	75	135
	B. In totally enclosed motors (thermocouple or resistance method)	80	144
11.	Class 105 insulation systems on windings of relays, solenoids, magnets, and the like: <sup>b</sup>		
	Thermocouple method	65	117
	Resistance method	75	135

(Continued)

**Table 26.1 (Cont'd)**  
**Maximum temperature rises**

Materials and component parts		Degrees C	Degrees F
12.	Class B insulation systems on coil windings of d-c and universal motors: <sup>b</sup>		
	A. In open motors:		
	Thermocouple method	85	153
	Resistance method	95	171
	B. In totally enclosed motors:		
	Thermocouple method	90	162
	Resistance method	100	180
13.	Class B insulation systems on coil windings of a-c motors: <sup>b</sup>		
	A. In open motors (thermocouple or resistance method)	95	171
	B. In totally enclosed motors (thermocouple or resistance method)	100	180
14.	Class 130 insulation systems on windings of relays, solenoids, magnets, and the like: <sup>b</sup>		
	Thermocouple method	85	153
	Resistance method	95	171
15.	Phenolic composition employed as electrical insulation or as a part whose failure would result in a risk of fire or electric shock <sup>d</sup>	125	225
16.	All rubber or thermoplastic insulation wires and cords except those mentioned in item 15 <sup>a</sup>	35	63
17.	Types RFH-1, RFH-2, FFH-1, FFH-2	50	90
18.	Sealing compounds	40EC(104EF) less than the melting point	
19.	Capacitors	25EC(77EF) less than the marked limit	
<p><sup>a</sup> This temperature limit is concerned with wire insulation which may contact these points.</p> <p><sup>b</sup> See 26.11.</p> <p><sup>c</sup> Contacts of silver or a silver alloy in a device which is designated to function where a high ambient temperature prevails are acceptable without any special additional tests if they do not attain a temperature higher than 100EC (212EF) when the device is tested at the ambient temperature in question. If the contacts attain a temperature higher than 100EC (212EF) but not higher than 150EC (302EF), they are required to be capable of withstanding with acceptable results overload and endurance tests conducted at the high ambient temperature in question. A temperature attained on contacts in excess of 150EC (302EF) is not acceptable.</p> <p><sup>d</sup> The limitation on phenolic composition and on rubber and thermoplastic insulation does not apply to compounds which have been investigated and recognized as having special heat-resistant properties.</p>			

26.9 The resistance method consists of the determination of the temperature of a copper or aluminum winding by comparing the resistance of the winding at the temperature to be determined with the resistance at a known temperature, according to the formula:

$$t = \frac{R}{r} (k + t_1) - (k + t_2)$$

*in which:*

*t is the temperature rise,*

*R is the resistance of the winding at the end of the test,*

*r is the resistance of the winding (winding at  $t_1$ ) at the beginning of the test,*

*$t_1$  is the room temperature EC at the beginning of the test,*

*$t_2$  is the room temperature EC at the end of the test, and*

*k is 234.5 for copper, 225.0 for electrical conductor grade (EC) aluminum. Values of the constant for other grades must be determined.*

26.10 As it is generally necessary to de-energize the winding before measuring R, the value of R at shutdown may be determined by taking several resistance measurements at short intervals, beginning as quickly as possible after the instant of shutdown. A curve of the resistance values and the time may be plotted and extrapolated to give the value of R at shutdown.

26.11 Except at coils, temperature readings are to be obtained by means of thermocouples consisting of wires not larger than No. 24 AWG, and a temperature is considered to be constant when three successive readings, taken at intervals of 10 percent of the previously elapsed duration of the test, but not less than 5-minute intervals, indicate no change. The primary (preferred) method of measuring temperatures on coils is the thermocouple method; but temperature measurements by either the thermocouple or resistance method are acceptable, except that the thermocouple method is not to be employed for a temperature measurement at any point where supplementary heat insulation is employed. When thermocouples are used in the determination of temperatures in connection with the heating of electrical devices, it is standard practice to employ thermocouples consisting of No. 30 AWG iron and constantan wires and a potentiometer-type of indicating instrument; and such equipment is to be used whenever referee temperature measurements by thermocouples are necessary.

26.12 For the thermocouple-measured temperature of a coil an alternating-current motor other than a universal motor (items 10 and 13 in Table 26.1), the thermocouple is to be applied to the magnet wire, or it is to be separated from that wire by no more than the insulation on the conductor itself. For the thermocouple-measured temperature of a coil of any other motor, the thermocouple is to be mounted as described above, or it may be separated from the conductor by no more than the insulation on the conductor itself and the normal coil wrap. Ordinarily, temperatures are to be measured by means of thermocouples.

26.13 To determine whether a switch complies with the requirements in 26.1 and 26.2, the switch is to carry its maximum rated current continuously until constant temperatures are attained on the plates of wiring terminals, or on wire leads used instead of wiring terminals. Unless the switch is provided with attached leads, connections to the switch are to be made with fixture or building wire in lengths not less than 12 inch (300 mm) and having 30 mils (0.76 mm) or greater average thickness of thermoplastic insulation, rated 60EC (140EF). The size of the wire is to be Nos. 18, 16, 14, 12, 10, 8, and 6 AWG, respectively, for test currents of 0 – 6, 6.1 – 10, 10.1 – 15, 15.1 – 20, 20.1 – 30, 30.1 – 45, and 45.1 – 60 A. The temperature test may be conducted at any convenient voltage, using either alternating or direct current.

## 27 Overload Test

27.1 A switch shall perform acceptably when subjected to an overload test consisting of making and breaking, for 50 cycles of operation, a test current at the test voltage and the rate indicated in Table 27.1. The device shall be electrically and mechanically operable at the conclusion of the test, at which time the switch shall be capable of performing its intended function and shall show no wear, loosening of parts, or defects of any other description that will diminish appreciably the usefulness of the device. The fuse described in 27.11 shall not operate to open the circuit.

27.2 One cycle of operation is considered to include all the switching activity involved in a start to finish operation of a controlled equipment, for example, the fill to spin interval associated with a clothes washing machine.

27.3 The load for pilot-duty rating shall consist of an electromagnet representative of the magnet-coil load that the device is intended to control. The current at rated voltage may be calculated from the voltage and volt-ampere rating of the device. For an alternating-current device, the power factor shall not be more than 0.35 and the inrush current shall be ten times the normal current. The test shall be conducted with the armature, if any, of the load free to move, that is, not blocked in either the open or closed position. The switch shall be electrically and mechanically operable at the conclusion of the test, at which time the device shall be capable of performing its intended function and shall show no wear, loosening of parts, or defects of any other description that will diminish appreciably the usefulness of the device. The fuse described in 27.11 shall not operate to open the circuit.

27.4 Tables 27.2 and 27.3 give full-load currents corresponding to motor horsepower ratings, and are to be used in determining load current for the various tests specified for horsepower-rated equipment.

27.5 A switch that has been found to be acceptable for controlling an alternating-current motor is acceptable for alternating-current pilot duty without further overload or endurance tests provided that:

- a) During the overload test, the contacts were caused to make and break, for 50 cycles of operation at a rate of 6 cycles per minute, a current having a value as indicated in the third column of Table 27.1 at a power factor of 0.5 or less; and
- b) The pilot-duty inrush current at the same voltage is not more than 67 percent of either the rated locked-rotor motor current of the device, or the locked-rotor current corresponding to the horsepower rating depending on the basis on which the device is rated.

27.6 If an ampere-rated device has the same ampere rating at more than one voltage, a test at the highest voltage is considered to be representative of tests at the lower voltages; but, if the device has a greater ampere rating at the lower voltage than at the higher ones, tests are to be made at the highest and lowest voltages.

27.7 If a horsepower-rated device has more than one voltage rating, the overload test or tests are to cover the conditions of maximum voltage, power, and current.

**Table 27.1**  
**Values of voltage and current for overload tests**

Device rated in	Test voltage	Test current	Power factor	Cycles per minute <sup>c</sup>
Amperes, AC	Rated Voltage See 24.4	1.5 times rated current	0.75–0.80 <sup>a</sup>	6
Amperes, DC	Rated Voltage See 24.4	1.5 times rated current	b	6
Horsepower, AC	Rated Voltage See 24.4	Six times the full load current indicated in Table 27.2	0.40–0.50	6
Horsepower, DC	Rated Voltage See 24.4	Ten times the full load current indicated in Table 27.2	b	6
Amperes, Full-load and locked-rotor motor current	Rated Voltage See 24.4	AC – Rated locked rotor	0.40–0.50	6
		DC – Rated locked rotor	b	6
Amperes (Tungsten)	Rated Voltage See 24.4	AC – 1.5 times rated current	0.75–0.80	6
Amperes (Tungsten)	Rated Voltage See 24.4	DC – 1.5 times rated current	b	6
Amperes (Inductive)	Rated Voltage See 24.4	AC – Three times current	0.40–0.50	6
Volt-Amperes	110 percent of Rated Voltage See 24.4	See 27.3	See 27.3	6

<sup>a</sup> If the device is marked for a resistive load only in accordance with 43.2, the test is to be conducted using a resistive load having a power factor of 0.95–1.0.

<sup>b</sup> Resistive load having a power factor of 0.95–1.0.

<sup>c</sup> The test cycle is to be 1 second on and 9 seconds off, if the nature of the device permits the test to be so made. Other test cycle rates may be used if agreeable to all concerned.



**Table 27.2**  
**Full-load motor-running currents in amperes corresponding to**  
**various a-c horsepower ratings**

Horsepower	110 – 120 V			220 – 240 V			440 – 480 V			550 – 600 V		
	Single phase	Two phase	Three phase	Single phase	Two phase	Three phase	Single phase	Two phase	Three phase	Single phase	Two phase	Three phase
1/10	3.0	—	—	1.5	—	—	—	—	—	—	—	—
1/8	3.8	—	—	1.9	—	—	—	—	—	—	—	—
1/6	4.4	—	—	2.2	—	—	—	—	—	—	—	—
1/4	5.8	—	—	2.9	—	—	—	—	—	—	—	—
1/3	7.2	—	—	3.6	—	—	—	—	—	—	—	—
1/2	9.8	4.0	4.0	4.9	2.0	2.0	2.5	1.0	1.0	2.0	0.8	0.8
3/4	13.8	4.8	5.6	6.9	2.4	2.8	3.5	1.2	1.4	2.8	1.0	1.1
1	16.0	6.4	7.2	8.0	3.2	3.6	4.0	1.6	1.8	3.2	1.3	1.4
1-1/2	20.0	9.0	10.4	10.0	4.5	5.2	5.0	2.3	2.6	4.0	1.8	2.1
2	24.0	11.8	13.6	12.0	5.9	6.8	6.0	3.0	3.4	4.8	2.4	2.7
3	34.0	16.6	19.2	17.0	8.3	9.6	8.5	4.2	4.8	6.8	3.3	3.9
5	56.0	26.4	30.4	28.0	13.2	15.2	14.0	6.6	7.6	11.2	5.3	6.1
7-1/2	80.0	38.0	44.0	40.0	19.0	22.0	21.0	9.0	11.0	16.0	8.0	9.0
10	100.0	48.0	56.0	50.0	24.0	28.0	26.0	12.0	14.0	20.0	10.0	11.0
15	135.0	72.0	84.0	68.0	36.0	42.0	34.0	18.0	21.0	27.0	14.0	17.0
20	—	94.0	108.0	88.0	47.0	54.0	44.0	23.0	27.0	35.0	19.0	22.0
25	—	118.0	136.0	110.0	59.0	68.0	55.0	29.0	34.0	44.0	24.0	27.0
30	—	138.0	160.0	136.0	69.0	80.0	68.0	35.0	40.0	54.0	28.0	32.0

<sup>a</sup> To obtain full-load currents for 208-V motors, increase corresponding 220 – 240 V ratings by 10 percent for single-phase motors and by 6 percent for 3-phase motors.

**Table 27.3**  
**Full-load motor-running currents in amperes**  
**corresponding to various d-c horsepower ratings**

Horsepower	110 – 120 V	220 – 240 V	550 – 600 V
1/10	2.0	1.0	–
1/8	2.2	1.1	–
1/6	2.4	1.2	–
1/4	2.9	1.5	–
1/3	3.6	1.8	–
1/2	5.2	2.6	–
3/4	7.4	3.7	1.6
1	9.4	4.7	2.0
1-1/2	13.2	6.6	2.7
2	17	8.5	3.6
3	25	12.2	5.2
5	40.0	20.0	8.3
7-1/2	58.0	29.0	12.0
10	76.0	38.0	16.0
15	112.0	55.0	23.0
20	148.0	72.0	31.0
25	184.0	89.0	38.0
30	220.0	106.0	46.0

27.8 All current-interrupting tests are to be made at the voltage indicated in 24.4. The open-circuit voltage of the supply circuit is to be not less than 100 percent nor more than 105 percent of the specified test voltage, except that a higher voltage may be employed if agreeable to those concerned. The current-carrying capacity of the supply circuit is to be such that the closed-circuit voltage with rated current flowing is within 2-1/2 percent of the specified test voltage.

27.9 A two-pole or four-pole device shall be tested on a single-phase or direct-current circuit. In a four-pole device intended to control a two-phase circuit, adjacent poles shall be used, one pole being that nearest metal that may be grounded in service. If the pole spacing varies, an additional test shall be made between the poles with the smallest spacing, to cover use on two-phase interconnected systems. See 43.6.

27.10 A device other than one described in 27.9 shall be tested in a circuit simulating intended service. See 43.6.

27.11 In the overload and endurance tests a fuse shall be connected between the enclosure and one supply terminal to indicate arc-over to the enclosure. The fuse is to be a 30 A nonrenewable, nontime-delay Class H fuse complying with the Standard for Class H Fuses, UL 198B having a voltage rating not less than the rating of the device being tested.

27.12 The supply terminal mentioned in 27.11 is to be the least likely to be involved in arc-over. The fuse mentioned in 27.11 is not to operate to open the circuit.

## 28 Endurance Test

28.1 The conditions for the endurance test shall be the same as the conditions for the overload test as indicated in 27.2 and 27.6 – 27.12.

28.2 A switch shall perform successfully when:

- a) Operated manually, or
- b) Operated by means of an appropriate machine, or
- c) Allowed to operate automatically as in intended service for the number of cycles and at the rate indicated in Table 28.1; except that if the rate indicated could not be obtained in intended service, the rate is to be adjusted accordingly.

28.3 Unless the switching components of a switch have been found to comply with the performance requirements in the Standard for Special-Use Switches, UL 1054, the device shall be caused to make and break its rated current at the voltage indicated in 24.4. The device shall be electrically and mechanically operable at the conclusion of the test, at which time the switch shall be capable of performing its intended function and shall show no wear, loosening of parts, or defects of any other description that will diminish appreciably the usefulness of the device. The fuse described in 27.11 shall not operate to open the circuit.

28.4 A switch intended for pilot duty shall perform acceptably when operated for the number of cycles indicated in Table 28.1, making and breaking a circuit of rated frequency, at the voltage indicated in 24.4 and at the rate of operation indicated in 28.5. The load shall consist of an electromagnet representative of the magnet-coil load that the device is intended to control. The normal current, which is the test current, is to be determined from the voltage and volt-ampere rating of the device. For an alternating-current device, the power factor shall not be more than 0.35 and the inrush current shall be ten times the normal current. The test shall be conducted with the armature of the load, if any, free to move, that is, not blocked in either the opened or closed position. The device shall be electrically and mechanically operable at the conclusion of the test, at which time the switch shall be capable of performing its intended function and shall show no wear, loosening of parts, or defects of any other description that will diminish appreciably the usefulness of the switch.

28.5 Unless the nature of the device requires a longer time to complete a cycle of operation, the rate of speed of operation for the test mentioned in 28.4 shall be as follows:

- a) For a device intended to be operated manually, the first 1000 cycles shall be at the rate of 1 cycle per second – except that the first 10 or 12 operations shall be made as rapidly as possible – and the remaining cycles shall be at the rate of 6 cycles per minute, with the device closed for approximately 1 second of each cycle.
- b) Where there is no provision for manual operation, the entire number of cycles shall be at the rate of 6 cycles per minute, with the device closed for approximately 1 second each cycle.

**Table 28.1**  
**Values of voltage and current for endurance tests**

Device rated in	Test potential	Test current	Power factor	Number of cycles	Cycles per minute
Amperes, AC, DC	Rated Voltage See 24.4	AC – rated	$0.75 - 0.80^d$	6000	$6^a$
		DC – rated		6000	$6^a$
Horsepower, AC	Rated Voltage See 24.4	AC – full-load current indicated in Table 27.2	0.75 – 0.80	6000	$6^a$
Horsepower, DC	0.5 times Rated Voltage See 24.4	DC – full-load current indicated in Table 27.3	b	6000	$6^a$
Full-load and locked- rotor amperes	Rated Voltage See 24.4	AC – rated full-load current	0.75 – 0.80	6000	$6^a$
		DC – rated full-load current	b	6000	$6^a$
Amperes (Tungsten)	Rated Voltage See 24.4	AC – rated current	e	6000	$1^c$
		DC – rated current	e	6000	$1^c$
Amperes (Inductive)	Rated Voltage See 24.4	Two times rated current	0.75 – 0.80	6000	$6^a$
Volt-Amperes Pilot Duty	Rated Voltage See 24.4	See 28.4	See 28.4	6000	See 28.4

<sup>a</sup> The test cycle is to be 1 second on and 9 seconds off, if the nature of device permits the test to be so made.

<sup>b</sup> Noninductive resistive load.

<sup>c</sup> The test cycle is to be as indicated in 27.2.

<sup>d</sup> If the device is marked for a resistive load only in accordance with 43.2 the test may be conducted using a noninductive load.

<sup>e</sup> The load shall consist of tungsten filament lamps or a load having equivalent characteristics. See 29.1 – 29.5.

## 29 Tungsten-Filament-Lamp Load Test

29.1 A switch with a tungsten lamp rating of not more than 60 A is to be tested with a tungsten-filament-lamp load so adjusted that the current flow is the rated current of the switch. The test circuit shall have such ampere capacity as to provide a current inrush through the switch and load of not less than ten times the rated current when the circuit is closed on a load equal to the switch rating, but not less than 20 A, and the circuit shall be such that the peak value of inrush current will be reached within 1/240 of a second after the circuit is closed.

29.2 A synthetic load and a combination synthetic and tungsten-filament lamp load for testing on alternating current shall be investigated as described in 29.3 and 29.10, and also with respect to special conditions which are introduced by use on alternating current.

29.3 The acceptability of a test circuit, including the generator or other source of supply, for testing with tungsten-filament lamps is to be determined by means of oscillograph studies. With reference to a 60 Hz timing wave, the peak values of inrush current as shown by oscillograms are to be reached within 1/4 cycle.

29.4 A tungsten-filament-lamp load and the supply circuit need not provide the inrush current required for a 20 A load if when tested for a lower current rating the available inrush current is adequate for the lower rating and testing is limited to the lower rating as a maximum.

29.5 The characteristics of a direct-current test circuit are to be determined from a number of oscillograms, 12 or more, and testing equipment is acceptable if not less than half the oscillograms show the minimum acceptable or a greater current-inrush factor.

29.6 The characteristics of an alternating-current test circuit are also to be determined from a number of oscillograms, 12 or more. Those that indicate that the current is decreasing (that the part of the sine wave in question is approaching the zero point) should be disregarded. Twelve or more oscillograms taken at other points on the sine wave should show whether the capacity of the test circuit is such as to produce the minimum acceptable current-inrush factor based on observed peak values.

29.7 The acceptability of a test circuit (including the generator or other source of supply) for testing with a synthetic load is to be determined in a manner similar to that described in 29.6.

29.8 If tungsten-filament lamps are used as the load for a switch intended for use with such lamps, the load is to be made up of the smallest possible number of lamps having standard ratings. In determining the smallest number of lamps necessary, the maximum lamp size required to be used is 500 W. Larger lamps may be used if desired. The operating cycle is to be such that the lamps are off for at least 55 seconds of each test cycle.

29.9 If the switch has other ratings as well as the tungsten rating, a separate representative device may be used for the Tungsten-Filament-Lamp Load Endurance Test if it has been subjected to an overload test also.

29.10 A synthetic load may be used instead of tungsten-filament lamps and may consist of noninductive resistors if they are so connected and controlled that a portion of the resistance is shunted during the closing of the switch under test or if a portion of the load is cut out prior to opening the switch. A synthetic load may also consist of a noninductive resistor or resistors and a capacitor in parallel, in which case the load is to be calibrated immediately after the capacitor has been charged and discharged. A combination load consisting of tungsten-filament lamps and resistors, or resistors and capacitor, is to be considered a synthetic load.

29.11 If a synthetic load is used instead of tungsten-filament lamps, it is to be calibrated against and is to be equivalent to a tungsten-filament-lamp load in the test circuit. The calibration of a synthetic load is to be checked at intervals to determine that none of the constants of the circuit or load change with time or use.

29.12 The characteristics of a synthetic load are to be such that the inrush current will be as specified in 29.1. In addition, the current in the capacitor/resistance load or the combination load mentioned in 29.10 is not to be less than one-half of the required inrush current at 1/60 second and not less than twice the steady-state current at 7/120 second after the circuit is closed; and the current in a straight resistance load is to be the full inrush value for a minimum of 15 milliseconds after the switch is closed.

29.13 If tests are made with alternating current, the circuit frequency shall be the same as the rated frequency of the switch, except as noted in 29.14, or, if no frequency is indicated, 60 Hz alternating current shall be used, except that in either case a lower frequency may be employed if agreeable to those concerned.

29.14 A switch rated 50 Hz may, if agreeable to those concerned, be tested on a 60 Hz circuit except that the current used for the overload and endurance test shall be 120 percent of the current that would have been used had this switch been tested on a 50 Hz circuit.

### **30 Test Conditions**

30.1 A switch shall not be adjusted, lubricated, or otherwise conditioned either before or during any of the tests.

30.2 The requirement in 30.1 does not apply to a regular manufacturing practice of lubricating switches as they are assembled.

30.3 During the overload, and all endurance tests, the switch shall be so mounted and wired that conditions of actual service conditions will be represented, and shall be connected to the indicated load and to a supply circuit, the voltage of which is within 5 percent of the rated voltage of the device. The capacity of the test circuit shall be such that the potential across the load, measured at or adjacent to the switch, will have the required value when the switch under test is closed in the circuit with the required test current flowing. See 27.11 and 27.12.

30.4 With reference to the requirement in 30.3, it is impractical to describe the details of connections that must be made to obtain operating conditions identical with those in actual service because of the different arrangements of terminals of devices of various switches. In any case, however, the connections to the device in the test circuit are to be such that the load controlled will have the same position, relative to the device and the supply, that it will have in actual service.

30.5 As a rule, the device is to be connected in the test circuit between the supply and the load.

### **31 Rain Test**

31.1 To determine compliance with the requirements in 7.1, the enclosure shall be subjected to the Rain Test described in 31.2. There shall be no significant accumulation of water within the enclosure and no water shall enter the enclosure at a level higher than the lowest live part, except that water may enter above live parts if the device is so constructed that no water is visible on the live parts, insulating material, or operating mechanism parts, and no water has entered any space above the live parts within the enclosure in which wiring may be present under any proper installation conditions.

Figure 31.1  
Rain-Test spray head

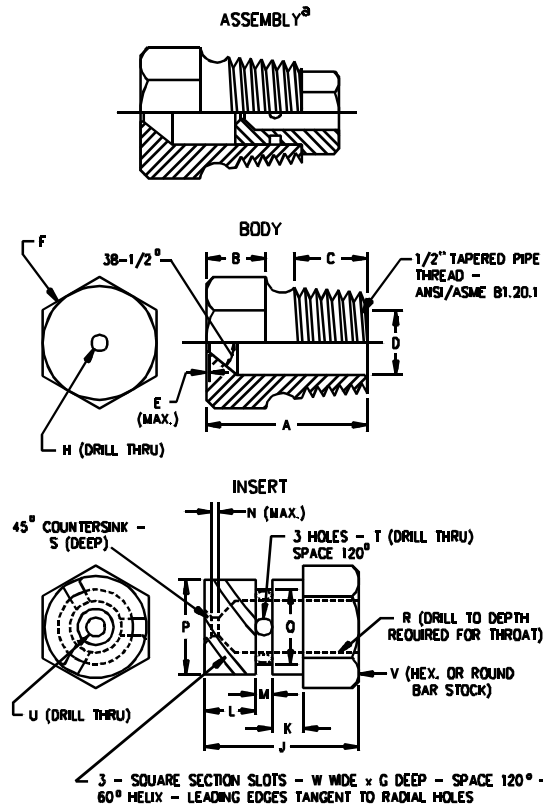

Item	inch	mm	Item	inch	mm
A	1-7/32	31.0	N	1/32	0.80
B	7/16	11.0	P	.575	14.61
C	9/16	14.0	Q	.576	14.63
D	.578	14.68	R	.453	11.51
	.580	14.73		.454	11.53
E	1/64	0.40	R	1/4	6.35
F	c	c	S	1/32	0.80
G	.06	1.52	T	(No. 35) <sup>b</sup>	2.80
H	(No. 9) <sup>b</sup>	5.0	U	(No. 40) <sup>b</sup>	2.50
J	23/32	18.3	V	5/8	16.0
K	5/32	3.97	W	0.06	1.52
L	1/4	6.35			
M	3/32	2.38			

<sup>a</sup> Nylon Rain-Test Spray Heads are available from Underwriters Laboratories

<sup>b</sup> ANSI B94.11M Drill Size

<sup>c</sup> Optional – To serve as a wrench grip.

31.2 The device is to be set up as in a normal installation with conduit connections – without pipe compound – if so intended. The tightening torque for rigid conduit threaded into the opening in the enclosure is to be 800 lbf-in (90 N•m) for 3/4 inch and smaller trade sizes, 1000 lbf-in (181 N•m) for 2 inch and larger trade sizes. The device is to be positioned in the focal area of the three spray heads so that the greatest quantity of water is likely to enter the device. The water pressure is to be maintained at 5 psig (34 kPa) at each spray head. The device is to be exposed to the water spray for 1 hour. Figures 31.1 and 31.2 indicate the nozzle construction and spray head piping.



**Figure 31.2**  
**Rain-Test spray head piping**

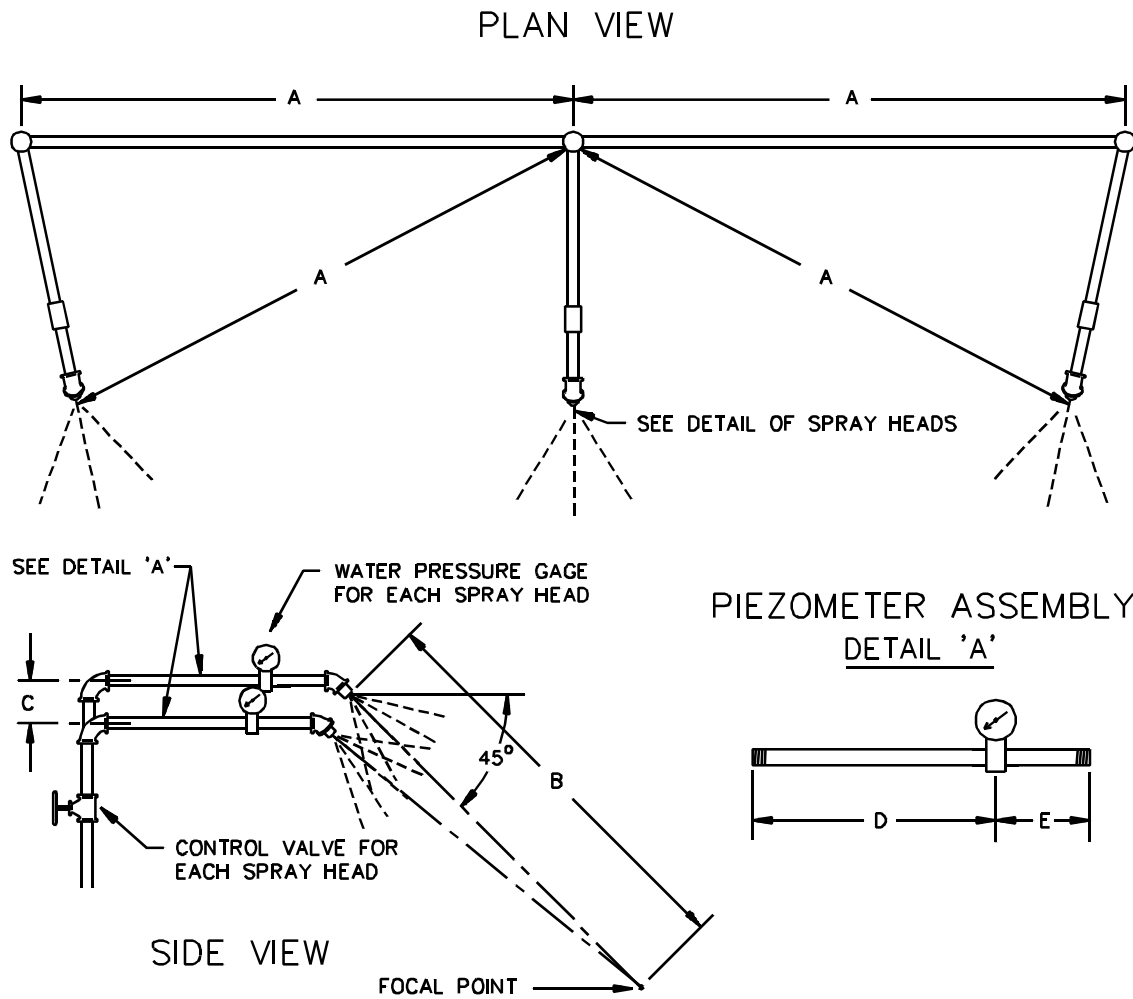

Item	inch	mm
A	28	710
B	55	1400
C	2-1/4	55
D	9	230
E	3	75

RT101E

\*Figure 31.2 revised February 27, 1998\*

No Text on This Page

### 32 Dielectric Voltage-Withstand Test

32.1 A switch shall withstand for a period of 1 minute the application of a 60 Hz sinusoidal potential of twice maximum rated voltage plus 1000 V:

- a) Between uninsulated live parts and dead metal and parts conductively connected to accessible dead metal with the contacts open and closed,
- b) Between terminals where there is a difference in potential with the contacts closed, and
- c) Between uninsulated live parts of different potentials.

32.2 A transformer, a motor winding, or a similar device normally connected between lines where there is a difference in potential is to be disconnected from one side of the line during the test described in item b) of 32.1.

32.3 If a barrier or liner is employed to insulate an exposed metal part, the device shall be capable of withstanding a Dielectric Voltage-Withstand Test, as indicated in 32.1, between uninsulated live parts and the exposed dead metal part. See also 22.8.

32.4 To determine that a switch complies with the requirements in 32.1, the switch is to be tested by means of a 500-VA or larger capacity transformer whose output voltage is sinusoidal and can be varied. The applied potential is to be increased from zero until the required test level is reached, and is to be held at that level for 1 minute. The increase in the applied potential is to be at a substantially uniform rate and as rapid as is consistent with its value being correctly indicated by a voltmeter. A direct current source or an alternating current source with a peak value equal to the direct current value may be used for testing a direct current circuit, if agreeable to those concerned.

32.5 A 500-VA or larger-capacity transformer need not be used in tests, if the transformer is provided with a voltmeter to measure directly the applied output potential.

32.6 Printed-wiring assemblies and other electronic circuit components that would be affected adversely by application of the test potential or that would short-circuit the test potential are to be removed, disconnected, or otherwise rendered inoperative before the dielectric voltage-withstand tests are made. A representative subassembly may be tested instead of an entire unit. Rectifier diodes in the power supply may be individually shunted before the test is made to avoid destroying them in the case of a fault elsewhere in the secondary circuits.

### 33 Impact Test

33.1 The 5 ft-lbf (6.8 J) impact applied to a part of an enclosure as required in 6.2.2, is to be obtained from a solid, smooth, steel sphere 2 inch (50.8 mm) in diameter and weighing 1.18 lb (0.535 kg). The sphere is allowed to fall freely from rest through the distance required to cause it to strike the top of the enclosure with the specified impact. For surfaces other than the top of the enclosure the sphere is to be suspended by a cord and allowed to fall as a pendulum through the distance required to strike the surface with the specified impact. The enclosure is placed so that the surface tested is vertical and in the same vertical plane as the point of support of the pendulum. Parts of the enclosure that may interfere with the cord of the pendulum are to be removed.

### 34 Metallic Coating Thickness Test

34.1 The method of determining the thickness of zinc or cadmium coating mentioned in 7.4 is described in 34.2 – 34.9.

34.2 The solution to be used for the test is to be made from distilled water and is to contain 200 g/l of reagent grade chromic acid,  $\text{CrO}_3$ ; and 50 g/L of reagent grade concentrated sulfuric acid,  $\text{H}_2\text{SO}_4$ . The latter is equivalent to 27 ml/l of reagent grade concentrated sulfuric acid, specific gravity 1.84, containing 96 percent of  $\text{H}_2\text{SO}_4$ .

34.3 The test solution is to be contained in a glass vessel such as a separatory funnel with the outlet equipped with a stopcock and a capillary tube having a 0.025 inch (0.64 mm) inside bore and a length of 5.5 inch (140 mm). The lower end of the capillary tube is tapered to form a tip, the drops from which are about 0.05 ml each. To preserve an effectively constant level, a small glass tube is inserted in the top of the funnel through a rubber stopper and its position is to be adjusted so that, when the stopcock is open, the rate of dropping is  $100 \pm 5$  drops per minute. If desired, an additional stopcock may be used in place of the glass tube to control the rate of dropping.

34.4 The representative device and the test solution should be kept in the test room long enough to acquire the temperature of the room, which should be noted and recorded. The test is to be conducted at a room temperature of 70 – 90EF (21 – 32EC).

34.5 Each representative device is to be thoroughly cleaned before testing. All grease, lacquer, paint, and other nonmetallic coatings are to be removed completely using solvents. Devices are then to be thoroughly rinsed in water and dried with clean cheesecloth. Care should be exercised to avoid contact of the cleaned surface with the hands or any foreign material.

34.6 The representative device to be tested is to be supported from 0.7 to 1 inch (18 to 25 mm) below the orifice, so that the drops of solution strike the point to be tested and run off quickly. The surface to be tested should be inclined about 45 degrees from horizontal.

34.7 The stopcock is to be opened and the time in seconds is to be measured with a stop watch until the dropping solution dissolves the protective metal coating, exposing the base metal. The end point is the first appearance of the base metal recognizable by the change in color at that point.

34.8 Each representation of a test lot is to be subjected to the test at three or more points – excluding cut, stenciled, and threaded surfaces – on the inside surface and at an equal number of points on the outside surface, at places where the metal coating may be expected to be the thinnest. On enclosures made from precoated sheets, the external corners that are subjected to the greatest deformation may have thin coatings.

34.9 To calculate the thickness of the coating being tested, select from Table 34.1 the thickness factor appropriate for the temperature at which the test was conducted and multiply by the time in seconds required to expose base metal as noted in 34.7.

**Table 34.1**  
**Thickness of coatings**

Temperature, degrees		Thickness factors, 0.00001 inches (0.00025 mm) per second	
F	(C)	Cadmium platings	Zinc platings
70	(21.1)	1.331	0.980
71	(21.7)	1.340	0.990
72	(22.2)	1.352	1.000
73	(22.8)	1.362	1.010
74	(23.3)	1.372	1.015
75	(23.9)	1.383	1.025
76	(24.4)	1.395	1.033
77	(25.0)	1.405	1.042
78	(25.6)	1.416	1.050
79	(26.1)	1.427	1.060
80	(26.7)	1.438	1.070
81	(27.2)	1.450	1.080
82	(27.8)	1.460	1.085
83	(28.3)	1.470	1.095
84	(28.9)	1.480	1.100
85	(29.4)	1.490	1.110
86	(30.0)	1.501	1.120
87	(30.6)	1.513	1.130
88	(31.1)	1.524	1.141
89	(31.7)	1.534	1.150
90	(32.2)	1.546	1.160

### 35 Gasket Tests

35.1 A gasket of rubber or neoprene, or a composition thereof, is to be exposed for 96 hours to oxygen at a pressure of 300 psig (2.07 MPa) and a temperature of 70EC (158EF). The gasket is considered resistant to aging if there is no visible evidence of deterioration such as softening, hardening, or cracking after flexing.

35.2 A gasket of thermoplastic material, or a composition thereof, may be accepted after consideration of the effects of heat aging, distortion under conditions of use, and the means of securing the gasket to the cover or enclosure.

35.3 A representation of the enclosure with the gasket cemented in place is to be exposed to a temperature of 100EC (212EF) for a duration of 72 hours. The adhesive cement is considered to be resistant to aging if at the end of this period there is no apparent loss of adhesion or dislodgment of the gasket as a result of this exposure.

### 36 Grounding Resistance Test

36.1 The resistance between the point of connection of the equipment grounding means, at or within the device, and any other point in the grounding circuit shall not be more than 0.1 ohm.

36.2 Compliance with the requirements of 36.1 is to be determined by any appropriate instrument; except that if unacceptable results are recorded, an alternating current of at least 20 A from a power supply of not more than 12 V is to be passed from the point of connection of the equipment

grounding means to the metal part in the grounding circuit, and the resulting drop in potential is to be measured between the two points. The resistance in ohms is to be determined by dividing the drop in potential in volts by the current in amperes passing between the two points. The grounding conductor of a power supply cord is not to be included in this measurement.

### **37 Strain Relief Test**

37.1 When tested in accordance with 37.2, the strain-relief means provided on the flexible cord shall withstand for 1 minute, without displacement, a direct pull of 35 lbf (156 N) applied to the cord, with the connections within the device disconnected.

37.2 The specified force is to be applied to the cord and so supported by the device that the strain-relief means will be stressed from any angle that the construction of the device permits. The strain relief is not acceptable if, at the point of disconnection of the conductors, there is such movement of the cord as to indicate that stress on the connections would have resulted.

### **38 Snap-On Cover Tests**

38.1 A snap-on cover as mentioned in 6.5.2 that can be released from securement with one hand by a squeezing force shall not be released when a squeezing force of 14 lbf (62.3 N) is applied at any two points, the distance between which shall not exceed 5 inch (127 mm), as measured by a tape stretched tightly over that portion of the surface of the cover that would be encompassed by the palm of the hand. The test shall be performed before and after ten removal-and-replacement operations.

38.2 A snap-on cover shall not become disengaged from the case when a direct pull of 14 lbf (62.3 N) is applied. For this test, the cover is to be gripped at any two convenient points. The test shall be performed before and after ten removal-and-replacement operations.

38.3 A cover shall be capable of withstanding an impact of 1 ft-lbf (1.36 J) applied to the accessible faces of the cover, one impact per face, without being displaced. A steel ball, 2 inch (50.8 mm) in diameter and weighing 1.18 lb (0.535 kg) is to be used for this test.

### **39 Knockout Secureness Test**

39.1 A knockout shall remain in place when a 10 lbf (44.5 N) is applied at right angles to the knockout by means of a mandrel with a 1/4-inch (6.4-mm) diameter flat end. The mandrel shall be applied at the point most likely to cause movement of the knockout.

### **40 Humidity Test**

40.1 A clock-operated switch for coil windings employing insulation material likely to be affected adversely by moisture under conditions of normal use shall have an insulation resistance of not less than 50,000 ohms between current-carrying parts and interconnected noncurrent-carrying conductive parts after exposure for 48 hours to moist air having a relative humidity of  $85 \pm 5$  percent at a temperature of  $32.0 \pm 2.0^{\circ}\text{C}$  ( $89.6 \pm 3.6^{\circ}\text{F}$ ).

## 41 Abnormal Operation Test

\*Added Section 41 effective December 17, 1997\*

41.1 When tested in accordance with 41.2, there shall not be ignition of the enclosure material, exposure of live parts, emission of flame or molten metal, nor glowing or flaming of the material upon which the equipment is mounted. The disturbance shall be confined by the enclosure. The disturbance shall not result in a risk of fire, electric shock, or injury to persons; in parts to become accessible; or in reduction of spacings to below the required levels.

41.2 The equipment is to be operated under the most adverse condition of abnormal operation such as stalled-rotor, blocked-armature of relay, burnout of transformer or operation with current-carrying parts short-circuited, and the like. During the test, the equipment is to rest on white tissue paper on a softwood surface and is to be operated continuously until the ultimate results have been determined. In most cases, continuous operation will be necessary until constant temperatures are reached.

## RATINGS

### 42 Details

42.1 A switch shall be rated in volts, and, as appropriate for the intended use, in one or more of the following: amperes, horsepower, both full-load and locked-rotor motor current, volt-amperes, or watts. A rating in watts if provided shall be accompanied by a rating in amperes, also the rating shall indicate whether the device is for direct or alternating current.

42.2 A cord-connected or plug-in switch that operates on and off once in 24 hours shall have a tungsten-filament-lamp load rating. See 43.3.

42.3 The rating of an alternating-current switch shall include the number of phases and, if there is a motor, the frequency, except that a device obviously intended for single-phase use only need not include the phase rating.

42.4 A permanently connected switch intended for pilot duty shall be rated in amperes or volt-amperes. The rating shall not be less than 125 VA unless the switch is marked for use with a specific magnet-coil load. See 43.2.

42.5 A permanently connected switch may be rated for noninductive resistance loads, tungsten-filament-lamp loads, or highly inductive loads provided the switch is marked with its intended use. See 43.2.

42.6 The following standard voltages are applicable to switches, but other voltage ratings may be used.

AC: 120, 120/240, 208, 240, 277, 277/480, 480, 600.

DC: 125, 125/250, 250.

## MARKINGS

### 43 Details

43.1 A switch shall be plainly marked with the manufacturer's name, trademark, or other descriptive marking by which the organization responsible for the product can be identified, a distinctive catalog number or the equivalent, and the electrical rating. All markings shall be so located as to be visible and in the case of a permanently connected switch shall be visible after installation. See 43.5.

43.2 A permanently connected switch intended for the control of a certain type load shall be marked with the appropriate designation or an acceptable abbreviation or a combination of the markings, for example:

- a) "Resistance only" or "R" if intended for noninductive resistance loads,
- b) "Tungsten" or "T" if intended for the control of tungsten-filament-lamp loads,
- c) "Inductive" or "H" if intended for the control of high inductive loads such as gas-tube-sign transformers, fluorescent lamp loads, and the like,
- d) "Pilot duty" or "PD" if intended for the control of a magnet-coil load.

43.3 Unless a cord-connected or plug-in switch is acceptable for use with a full load of tungsten-filament lamps, it shall be marked to indicate the maximum connected incandescent lamp load in watts. The value of lamp wattage is to be not less than that equivalent to one-tenth of the full-load rating.

43.4 A cord-connected switch employing Type HPN cord involving a current rating greater than the equivalent size Type SP-2 cord, shall be marked "Replace with Type HPN cord only," or an equivalent marking that need not be visible until the switch is opened for cord replacement.

43.5 Markings, as indicated in 43.1, are not required to be located on the outside of an enclosure provided they are readily visible by opening a door or removing a cover after installation.

43.6 Unless the proper wiring connections are plainly evident on permanently connected switches, wiring terminals shall be marked or, the equipment provided with a wiring diagram to indicate the connections. If a wiring diagram is provided, it shall be located in accordance with 43.1 and 43.5. If information is necessary for the proper operation of the device, it shall be provided and shall be attached securely to the switch.

43.7 If any point within a terminal box or wiring compartment of a permanently connected switch in which field-installed conductors are intended to be connected, including such conductors themselves, attains a temperature higher than 60EC (140EF) during the normal-temperature test, the appliance shall be legibly marked "For supply connections, use \_\_\_ AWG or larger wires suitable for at least \_\_\_EC (\_\_\_EF)" or with an equivalent statement, and the temperature value shall be in accordance with Table 43.1. The wire size need not be included if No. 14 AWG wire was used during the test. This wording shall be located at or near the point where the supply connections are to be made and shall be clearly visible during installation and examination of the supply-wiring connections.

**Table 43.1**  
**Temperature for marking**

Temperature attained in terminal box or compartment during test		Temperature marking
61.0–75.0EC	(141.8–167.0EF)	75EC (167EF)
76.0–90.0EC	(168.8–194.0EF)	90EC (194EF)



43.8 If the manufacturer produces or assembles switches at more than one factory, each finished item of equipment shall have a distinctive marking, which may be in code, by which it may be identified as the product of a particular factory.

43.9 If any terminal of a permanently connected switch (see 43.13) is marked to indicate that aluminum wire may be used at that terminal (such as being marked with the symbol "AL") and if such marking is visible under the conditions described in 43.14, the device shall be marked in accordance with 43.10, 43.11, or 43.12, whichever applies.

43.10 If, because of wiring space or other factors, such as galvanic action and mechanical problems, terminals of a permanently connected switch are not intended for use with aluminum conductors, the device shall be marked "Use copper wire only."

43.11 If the wiring space and other factors are such that all terminals of a permanently connected switch are intended for use with aluminum conductors as well as with copper conductors, the device shall be marked "Use copper or aluminum wire."

43.12 If the wiring and other factors are such that some terminals of a permanently connected switch are intended for use with aluminum conductors as well as with copper conductors while the remainder of the terminals are intended for use with copper conductors only, the device shall be marked "Use copper wire only except at terminals\_\_\_\_". The marking shall positively identify the terminals that are intended for use with aluminum wire.

43.13 The word "terminal" as used in 43.9 – 43.12 signifies any terminal of the switch as well as a terminal of any component unit (circuit breaker, fuse, and the like) that is installed or intended to be installed in the device.

43.14 The term "visible" as used in 43.9 signifies a marking that will be visible when a front or trim has been removed or when a hinged cover has been opened. A marking on a separately supplied connector or a connector or part thereof that is likely to be removed or displaced during the wiring operation is considered to be visible.

43.15 Only the quoted words in 43.10 – 43.12 shall be used when these markings are provided, and any abbreviation designating copper and aluminum shall be "CU-AL" or "AL-CU."

*Exception: A marking employing a wording differing from that given in 43.12 may be accepted if it clearly and completely conveys the significant information.*

43.16 The characters in the markings described in 43.10 – 43.12 shall not be less than 3/32 inch (2.4 mm) in height.

## **TV RATED SWITCHES**

### **GENERAL**

#### **44 Details**

44.1 The paragraphs under this heading apply specifically to clock-operated television switches incorporating TV rated designations marked in accordance with 56.1, and are supplemental to Sections 6 – 23.

## CONSTRUCTION

### 45 Enclosure

#### 45.1 General

45.1.1 The term enclosure refers to that enclosure surrounding the contacts of the switch. If an enclosure around the switch contacts is not provided, an enclosure of the complete clock-operated switch is required and is then considered as the enclosure.

#### 45.2 Insulating material

45.2.1 Insulating materials used as any part of an enclosure of a television switch shall be classified 94V-0 complying with the Standard for Tests for Flammability of Plastic Materials for Parts in Devices and Appliances, UL 94.

45.2.2 Insulating materials used as any part of an enclosure of a television switch shall have arc-tracking characteristics as determined by Test for High-Voltage, Low-Current, Dry-Arc Resistance of Solid Electrical Insulation, ASTM D495-71 with a minimum arcing time of 180 seconds.

45.2.3 Insulating materials used within an enclosure of a television switch shall be classified 94HB or 94V-2 or better complying with the Standard for Tests for Flammability of Plastic Materials for Parts in Devices and Appliances, UL 94.

45.2.4 For sleeving, tape, and tubing on wires that involve a risk of fire or electric shock, see 12.4.

#### 45.3 Switch enclosure openings

45.3.1 The total unused area of all openings in a television switch enclosure shall not exceed 0.05 inch<sup>2</sup> (32 mm<sup>2</sup>). An insulating material that projects into or through the opening shall meet the requirements in 45.2.1 and 45.2.2. Parts of the switch mechanism that are not in the plane of the opening shall be disregarded in making this measurement.

#### 45.4 Wire leads

45.4.1 Wire leads, if provided, shall be acceptable for the purpose and have VW-1 flame-resistant properties. Wires having VW-1 flame-resistant properties are identified by the designation "VW-1" surface-printed on the wire insulation, or printed on an attached tag, or both.

## PERFORMANCE

### 46 General

46.1 Each of six representative devices of a television clock-operated switch in commercial form shall acceptably complete the tests described in Sections 46 – 54. One set of devices shall be used throughout all the tests. During these tests, there shall be no warping, cracking, or blistering of the switch enclosure. Discoloration of the enclosure is acceptable.

46.2 A television clock-operated switch having more than one switch pole shall be tested with each pole controlling a separate load, with opposite polarity between poles.

46.3 The test sequence shall be overload, endurance, temperature, dielectric voltage withstand, continued endurance, and repeated dielectric voltage withstand.

#### 47 Test Circuit

47.1 A television switch shall be tested on overload and endurance with alternating current and with a tungsten-filament-lamp load, under the conditions described in 27.2, 29.13, 29.14, 30.1, and 30.2. The test circuit is to be as described in 29.1, 29.4, and 29.6, and the load is to be as described in 29.8.

*Exception No. 1: A tungsten-filament-lamp load and the supply circuit need only provide the test currents required for the switch rating(s) to be tested in accordance with Table 47.1.*

*Exception No. 2: A synthetic load to simulate a tungsten-filament-lamp load shall be as described in 29.2, 29.7, and 29.10 – 29.12 and shall provide the appropriate test current shown in Table 47.1, consistent with the switch rating.*

**Table 47.1**  
**Overload and endurance test currents**

Switch rating amperes	Overload test		Endurance test	
	Steady-state current (RMS)	Minimum inrush current (PEAK)	Steady-state current (RMS)	Minimum current (PEAK)
1	1.5 Amp	27 Amp	1 Amp	18 Amp
2	3.0 Amp	51 Amp	2 Amp	35 Amp
3	4.5 Amp	71 Amp	3 Amp	51 Amp
4	6.0 Amp	91 Amp	4 Amp	65 Amp
5	7.5 Amp	111 Amp	5 Amp	78 Amp

For tungsten-filament-lamp loads, a test circuit that will provide one of the peak inrush currents shown in the table for the overload test is considered to provide the peak inrush currents required for tests of a switch of a lower rating.

#### 48 Test Conditions

48.1 During the Overload and Endurance Tests, the test conditions shall be as described in 27.11, 27.12, and 30.1 – 30.5.

#### 49 Overload Test

49.1 A television switch shall perform acceptably when subjected to the Overload Test described in 49.2. The device shall be electrically and mechanically operable at the conclusion of the test, at which time the switch shall be capable of performing its intended function and shall show no wear, loosening of parts, or defects of any other description that will diminish appreciably the usefulness of the device.

49.2 The switch shall be operated manually by means of its actuating member for 50 cycles of operation at a rate of not more than 10 cycles per minute, making and breaking 150 percent of its rated current, except that the rate of operation may be greater than 10 cycles per minute if agreeable to those concerned.

49.3 If the blade or blades can be left in other than the full off or a full contact position the switch shall perform acceptably when subjected to the overload test when the blade or blades are moved from the full contact to an intermediate position only.

## **50 Endurance Test**

50.1 A television switch shall perform acceptably when subjected to 10,000 cycles of operation by means of its actuating member, either manually or by a machine, at a rate of 6 – 10 cycles per minute, making and breaking its rated current. The rate of operation may be greater than 10 cycles per minute if it is agreeable to those concerned. The device shall be electrically and mechanically operable at the conclusion of the test, at which time the switch shall be capable of performing its intended function and shall show no wear, loosening of parts, or defects of any other description that will diminish appreciably the usefulness of the device. The fuse described in 27.11 shall not operate to open the circuit.

## **51 Temperature Test**

51.1 A television switch shall carry its maximum rated current continuously when tested in accordance with 26.1 – 26.13.

## **52 Dielectric Voltage-Withstand Test**

52.1 While in a heated condition representing normal operating temperature a television clock-operated switch shall withstand the application of a 60 Hz, essentially sinusoidal potential in accordance with 32.1 – 32.4.

## **53 Continued Endurance Test**

53.1 Upon completion of the Overload, Endurance, Temperature, and Dielectric Voltage-Withstand tests described in Sections 49 – 52, the switch shall perform acceptably when subjected to an additional 15,000 cycles of operation as described in 50.1. At the conclusion of this test, the switch shall be capable of making and breaking the test load.

## **54 Dielectric Voltage-Withstand Test (Repeated)**

54.1 Following the Continued Endurance Test described in 53.1, a switch shall comply with the requirements in 52.1 in a repeated Dielectric Voltage-Withstand Test.

## **RATINGS**

### **55 Details**

55.1 A TV rated clock-operated switch shall be rated 1, 2, 3, 4, or 5 A at 120 V ac.

## **MARKINGS**

### **56 Details**

56.1 A TV rated clock-operated switch shall be plainly marked with the name or trademark of the manufacturer and the applicable type designation TV-1, TV-2, TV-3, TV-4, or TV-5. (The suffix number to correspond with the ampere rating at 120 V ac). The electrical rating shall not appear on the switch.

**Superseded requirements for****the Standard for****Clock-Operate Switches****UL 917, Fourth Edition**

The requirements shown are the current requirements that have been superseded by requirements in this edition. The numbers in parentheses refer to the new requirements with future effective dates that have superseded these requirements. To retain the current requirements, do not discard the following requirements until the future effective dates are reached.

5.2 (6.1.2) Electrical parts of a switch, other than a supply cord, shall be so located or enclosed that protection against unintentional contact with uninsulated live parts (see 2.4) will be provided.

\*6.1.2 effective until December 17, 1997\*

5.3 (6.1.3) Openings in the enclosure are considered acceptable if the probe illustrated in Figure 6.1 cannot contact uninsulated live parts or film-coated wire, when inserted point first into the opening in any direction or angle.

\*6.1.3 effective until December 17, 1997\*

**Figure 5.1 (6.1)**  
**Probe**

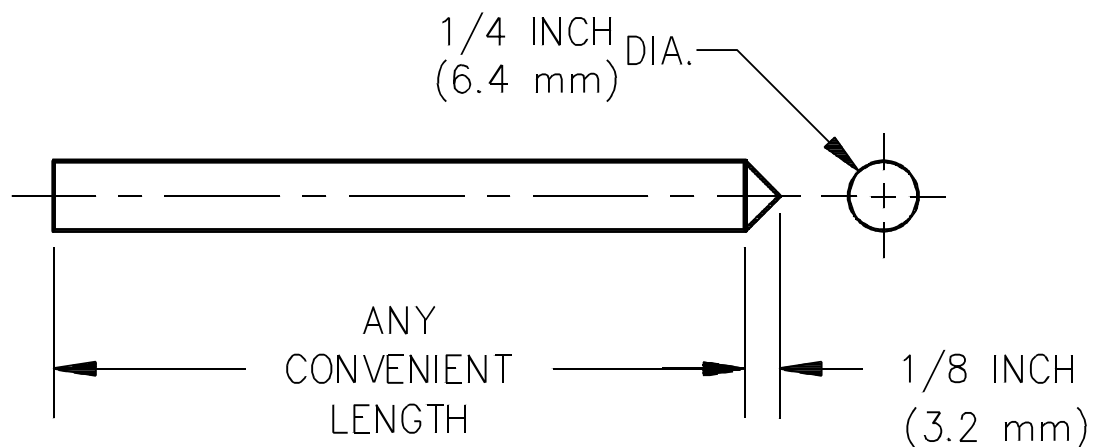

PA190

\*Figure 6.1 effective until December 17, 1997\*

5.4 (6.1.5) The probe indicated in 6.1.3 is to be applied without the part of the enclosure in place if any part of the enclosure either:

- a) Must be opened or removed in normal use with or without the use of tools, or
- b) Can be opened or removed without the use of tools.

*Exception: An enclosure employing a snap-on cover as indicated in 6.5.2 need not comply with this requirement.*

\*6.1.5 effective until December 17, 1997\*

6.2 (7.3) Holes for conduit shall be threaded unless they are located wholly below the lowest terminal lug or other live part within the enclosure, and there shall be provision for drainage of the enclosure.

\*7.3 effective until December 17, 1997\*