

# UL 122

ISBN 0-7629-0276-0

## Photographic Equipment



Underwriters Laboratories Inc. (UL)  
333 Pfingsten Road  
Northbrook, IL 60062-2096

UL Standard for Safety for Photographic Equipment, UL 122

Fourth Edition, Dated April 9, 1999

Revisions: This Standard contains revisions through and including July 11, 2001.

UL Standards for Safety are developed and maintained in the Standard Generalized Markup Language (SGML). SGML -- an international standard (ISO 8879-1986) -- is a descriptive markup language that describes a document's structure and purpose, rather than its physical appearance on a page. Due to formatting differences resulting from the use of UL's new electronic publishing system, please note that additional pages (on which no requirements have been changed) may be included in revision pages due to relocation of existing text and reformatting of the Standard.

Text that has been changed in any manner is marked with a vertical line in the margin. Changes in requirements are marked with a vertical line in the margin and are followed by an effective date note indicating the date of publication or the date on which the changed requirement becomes effective.

The new and/or revised requirements are substantially in accordance with UL's Bulletin(s) on this subject dated October 13, 2000. The bulletin(s) is now obsolete and may be discarded.

The revisions dated July 11, 2001 include a reprinted title page (page1) for this Standard.

The master for this Standard at UL's Northbrook Office is the official document insofar as it relates to a UL service and the compliance of a product with respect to the requirements for that product and service, or if there are questions regarding the accuracy of this Standard.

UL's Standards for Safety are copyrighted by UL. Neither a printed copy of a Standard, nor the distribution diskette for a Standard-on-Diskette and the file for the Standard on the distribution diskette should be altered in any way. All of UL's Standards and all copyrights, ownerships, and rights regarding those Standards shall remain the sole and exclusive property of UL.

All rights reserved. No part of this publication may be reproduced, stored in a retrieval system, or transmitted in any form by any means, electronic, mechanical photocopying, recording, or otherwise without prior permission of UL.

Revisions of UL Standards for Safety are issued from time to time. A UL Standard for Safety is current only if it incorporates the most recently adopted revisions.

UL provides this Standard "as is" without warranty of any kind, either expressed or implied, including but not limited to, the implied warranties of merchantability or fitness for any purpose.

In no event will UL be liable for any special, incidental, consequential, indirect or similar damages, including loss of profits, lost savings, loss of data, or any other damages arising out of the use of or the inability to use this Standard, even if UL or an authorized UL representative has been advised of the possibility of such damage. In no event shall UL's liability for any damage ever exceed the price paid for this Standard, regardless of the form of the claim.

UL will attempt to answer support requests concerning electronic versions of its Standards. However, this support service is offered on a reasonable efforts basis only, and UL may not be able to resolve every support request. UL supports the electronic versions of its Standards only if they are used under the conditions and operating systems for which it is intended. UL's support policies may change from time-to-time without notification.

UL reserves the right to change the format, presentation, file types and formats, delivery methods and formats, and the like of both its printed and electronic Standards without prior notice.

Purchasers of the electronic versions of UL's Standards for Safety agree to defend, indemnify, and hold UL harmless from and against any loss, expense, liability, damage, claim, or judgement (including reasonable attorney's fees) resulting from any error or deviation introduced while purchaser is storing an electronic Standard on the purchaser's computer system.

If a single-user version electronic Standard was purchased, one copy of this Standard may be stored on the hard disk of a single personal computer, or on a single LAN file-server or the permanent storage device of a multiple-user computer in such a manner that this Standard may only be accessed by one user at a time and for which there is no possibility of multiple concurrent access.

If a multiple-user version electronic Standard was purchased, one copy of the Standard may be stored on a single LAN file-server, or on the permanent storage device of a multiple-user computer, or on an Intranet server. The number of concurrent users shall not exceed the number of users authorized.

Electronic Standards are intended for on-line use, such as for viewing the requirements of a Standard, conducting a word search, and the like. Only one copy of the Standard may be printed from each single-user version of an electronic Standard. Only one copy of the Standard may be printed for each authorized user of a multiple-user version of an electronic Standard. Because of differences in the computer/software/printer setup used by UL and those of electronic Standards purchasers, the printed copy obtained by a purchaser may not look exactly like the on-line screen view or the printed Standard.

An employee of an organization purchasing a UL Standard can make a copy of the page or pages being viewed for their own fair and/or practical internal use.

The requirements in this Standard are now in effect, except for those paragraphs, sections, tables, figures, and/or other elements of the Standard having future effective dates as indicated in the note following the affected item. The prior text for requirements that have been revised and that have a future effective date are located after the Standard, and are preceded by a "SUPERSEDED REQUIREMENTS" notice.

New product submittals made prior to a specified future effective date will be judged under all of the requirements in this Standard including those requirements with a specified future effective date, unless the applicant specifically requests that the product be judged under the current requirements. However, if the applicant elects this option, it should be noted that compliance with all the requirements in this Standard will be required as a condition of continued Listing, Recognition, and Follow-Up Services after the effective date, and understanding of this should be signified in writing.

Copyright © 2001 Underwriters Laboratories Inc.

This Standard consists of pages dated as shown in the following checklist:

Page	Date
1-5 .....	July 11, 2001
6 .....	April 9, 1999
7-8B .....	July 11, 2001
9-43 .....	April 9, 1999
44-44B .....	July 11, 2001
45-49 .....	April 9, 1999
50-50B .....	July 11, 2001
51-52 .....	April 9, 1999
53 .....	July 11, 2001
54 .....	April 9, 1999
55-56 .....	July 11, 2001
57-60 .....	April 9, 1999
61-62 .....	July 11, 2001
63-93 .....	April 9, 1999
94-94B .....	July 11, 2001
95-98 .....	April 9, 1999
SA1-SA3 .....	July 11, 2001
SA4-SA6 .....	April 9, 1999
SA7 .....	July 11, 2001
SA8 .....	April 9, 1999
A1-A2 .....	April 9, 1999
CRG1 .....	April 9, 1999
CRG2 .....	July 11, 2001
CRG3-CRG10 .....	April 9, 1999
SR1-SR6 .....	April 9, 1999

No Text on This Page

**APRIL 9, 1999**  
(Title Page Reprinted: July 11, 2001)

1

**UL 122**

**Standard for Photographic Equipment**

First Edition – February, 1974  
Second Edition – August, 1984  
Third Edition – June, 1993

**Fourth Edition**

**April 9, 1999**

An effective date included as a note immediately following certain requirements is one established by Underwriters Laboratories Inc.

Revisions of this Standard will be made by issuing revised or additional pages bearing their date of issue. A UL Standard is current only if it incorporates the most recently adopted revisions, all of which are itemized on the transmittal notice that accompanies the latest set of revised requirements.

**ISBN 0-7629-0276-0**

**COPYRIGHT © 1974, 2001 UNDERWRITERS LABORATORIES INC.**

No Text on This Page



**CONTENTS**

<b>FOREWORD</b> .....	6
-----------------------	---

**INTRODUCTION**

1 Scope .....	7
2 General .....	8
2.1 Components .....	8
2.2 Units of measurement .....	8
2.3 Undated references .....	8
3 Terminology .....	.8A
4 Glossary .....	.8A

**CONSTRUCTION**

5 Moisture Condensation .....	10
6 Frame and Enclosure .....	10
6.1 General .....	10
6.2 Remotely- and automatically-controlled appliances .....	11
6.3 Enclosure material .....	12
7 Accessibility of Live Parts .....	14
7.1 Openings .....	14
7.2 Pin terminals .....	19
8 Mechanical Assembly .....	19
9 Protection Against Corrosion .....	20
10 Power Supply Connections .....	20
10.1 Cord-connected appliances .....	20
10.2 Permanently-connected appliances .....	25
11 Current-Carrying Parts .....	27
12 Internal Wiring .....	27
12.1 Mechanical protection .....	27
12.2 Types of wire .....	28
12.3 Splices and connections .....	28
13 Grounding and Bonding .....	29
13.1 Grounding .....	29
13.2 Bonding .....	31
14 Interconnecting Cords and Cables .....	32
15 Receptacles and Connectors .....	33
16 Separation of Circuits .....	34
17 Insulating Material .....	34
17.1 Electrical insulation .....	34
17.2 Thermal insulation .....	35
18 Overcurrent Protection .....	35
18.1 General .....	35
18.2 Motors .....	36
18.3 Lampholders and receptacles .....	37
18.4 Primary circuits .....	37
18.5 Secondary circuits .....	37
19 Short-Circuit and Ground-Fault Protection .....	38
20 Motors .....	39
21 Switching Devices .....	39

21.1	General	39
21.2	Rating	39
22	Lampholders	40
23	Medium- and High-Pressure Lamps	41
24	Capacitors	41
24.1	Motor and power-factor capacitors	41
24.2	Isolating capacitors	42
24.3	Interference elimination capacitors	42
24.4	Capacitor discharge	42
24.5	Capacitor rating	43
25	Transformers	43
26	Heating Elements	43
27	Printed-Wiring Boards	43
28	Lasers	43
29	Modems and Modem Cards	44
30	Spacings	44
30.1	General	44
30.2	Field-wiring terminal spacings	44
30.3	Primary circuit spacings	45
30.4	Limited-primary circuit spacings	46
30.5	Multiple spacings	46
30.6	Barriers for spacings	46
30.7	Secondary and battery circuit spacings	47
31	Secondary and Battery Circuits	47
32	Low-Voltage, Limited-Energy Circuits	47
33	Safety Circuits	49
34	Liquid Containers, Seals, and Diaphragms	49

## PROTECTION AGAINST INJURY TO PERSONS

35	General	50
36	Sharp Edges	50A
37	Enclosure of Moving Parts	50A
38	Stability	51
39	Strength of Handles	52
40	Glass Parts	52
41	Interlocks	52
42	Surface Temperatures	55
43	Cord Flexing	56
44	Marking	58

## PERFORMANCE

45	General	58
46	Resistance of Grounding Circuit	58
47	Leakage Current and Shock Current Tests	59
47.1	General	59
47.2	Leakage current	60
47.3	Shock current	64
47.4	Transient electric shock	65
47.5	Stored energy electric shock	67
47.6	Tube interchange and substitution	67
47.7	Standardized pin/socket arrangements	67

48	Leakage Current Following Humidity Conditioning Test	69
49	Operational Tests	70
50	Starting Current Test	70
51	Input Test	70
51.1	General	70
51.2	Maximum normal load	71
52	Temperature Test	73
52.1	General	73
52.2	Ambient temperatures	74
52.3	Temperature measurements	74
52.4	Operation for temperature test	78
53	Potential Measurements	78
54	Electrolytic Capacitor Test	78
55	Dielectric Voltage-Withstand Test	79
55.1	Primary circuits	79
55.2	Limited primary circuits	80
55.3	Secondary and battery circuits	80
55.4	Interconnecting cables	80
55.5	Maximum voltage	81
56	Abnormal Operation Tests	81
56.1	General	81
56.2	Test conditions	82
56.3	Components	83
56.4	Limited primary	83
56.5	Transformers	83
56.6	Silver recovery unit	83
57	Ozone Test	83
58	Strength of Enclosure Test	84
58.1	General	84
58.2	Wood, glass, and metal enclosures	84
59	Strain Relief Test	85
60	Cord and Cable Push-Back Relief Test	85
61	Fluid Entry Test	85

## MANUFACTURING AND PRODUCTION TESTS

62	Dielectric Voltage-Withstand Test	86
63	Electrical Continuity Test	87
63.1	Grounding continuity	87
63.2	Grounded conductor	88

## RATING

64	Electrical Rating	88
----	-------------------	----

## MARKING

65	General	88
66	Informational	88
66.1	Identification and rating	88
66.2	Alternate supply voltages	89
66.3	Multiple factory	89
66.4	Lamp replacement	89

66.5	Other than general-purpose receptacle .....	90
66.6	On-off switch .....	90
66.7	Wiring compartment .....	90
66.8	Use of circuit breaker or time-delay fuses .....	91
66.9	Projector for professional use .....	91
66.10	Component replacement .....	91
66.11	Supply circuit and overcurrent protective device .....	91
67	Cautionary .....	91
67.1	General .....	91
67.2	Ultraviolet lamp .....	92
67.3	High-pressure lamp .....	92
67.4	Capacitor discharge .....	92
67.5	Battery .....	92
67.6	Hot surface .....	92
67.7	Servicing .....	92
67.8	Fuse replacement .....	93
67.9	Bonding .....	93
67.10	Flammable film .....	93
67.11	Ungrounded dead-metal parts .....	93
67.12	Stability .....	93
67.13	Lasers .....	93

## INSTRUCTIONS

68	General .....	94
69	Safety Instructions .....	94A

## ACCESSORY EQUIPMENT

70	General .....	96
71	Construction .....	96
72	Performance .....	97
72.1	General .....	97
72.2	Installation and operation .....	97
73	Marking .....	97

## SUPPLEMENT SA - HIGH-PRESSURE LAMPS AND LAMP SYSTEMS

SA1	Scope .....	SA1
SA2	Glossary .....	SA1
SA3	General .....	SA2
SA4	Enclosure .....	SA2
SA5	Internal Construction .....	SA3
SA6	General .....	SA3
SA7	Power Input Test .....	SA3
SA8	Normal Temperature Test .....	SA3
SA9	Dielectric Voltage-Withstand Test .....	SA4
SA10	Abnormal Operation Test .....	SA5
SA11	Nonmetallic Enclosure Test .....	SA5
SA12	Oven Conditioning .....	SA6
SA13	Resistance to Impact Test .....	SA6

SA14 Ozone Test .....SA7  
SA15 Hot Restrike Test .....SA7  
SA16 General .....SA7

**APPENDIX A**

Standards for Components..... A1

**CANADIAN REQUIREMENTS COMPARISON GUIDE CRG 122**

UL AND CANADIAN STANDARDS FOR PHOTOGRAPHIC EQUIPMENT .....CRG1

## FOREWORD

A. This Standard contains basic requirements for products covered by Underwriters Laboratories Inc. (UL) under its Follow-Up Service for this category within the limitations given below and in the Scope section of this Standard. These requirements are based upon sound engineering principles, research, records of tests and field experience, and an appreciation of the problems of manufacture, installation, and use derived from consultation with and information obtained from manufacturers, users, inspection authorities, and others having specialized experience. They are subject to revision as further experience and investigation may show is necessary or desirable.

B. The observance of the requirements of this Standard by a manufacturer is one of the conditions of the continued coverage of the manufacturer's product.

C. A product which complies with the text of this Standard will not necessarily be judged to comply with the Standard if, when examined and tested, it is found to have other features which impair the level of safety contemplated by these requirements.

D. A product employing materials or having forms of construction which conflict with specific requirements of the Standard cannot be judged to comply with the Standard. A product employing materials or having forms of construction not addressed by this Standard may be examined and tested according to the intent of the requirements and, if found to meet the intent of this Standard, may be judged to comply with the Standard.

E. UL, in performing its functions in accordance with its objectives, does not assume or undertake to discharge any responsibility of the manufacturer or any other party. The opinions and findings of UL represent its professional judgment given with due consideration to the necessary limitations of practical operation and state of the art at the time the Standard is processed. UL shall not be responsible to anyone for the use of or reliance upon this Standard by anyone. UL shall not incur any obligation or liability for damages, including consequential damages, arising out of or in connection with the use, interpretation of, or reliance upon this Standard.

F. Many tests required by the Standards of UL are inherently hazardous and adequate safeguards for personnel and property shall be employed in conducting such tests.

## INTRODUCTION

### 1 Scope

1.1 These requirements cover electrically-operated, cord-connected photographic equipment rated 300 V or less, and permanently connected photographic equipment rated 600 volts or less, intended for household or commercial use on interior wiring systems in accordance with the National Electrical Code, NFPA 70. These requirements also cover battery-powered photographic equipment involving a risk of fire or electric shock.

1.2 These requirements cover motion picture projectors, including those intended for use in motion picture theaters; still picture projectors; equipment intended for use in taking photographs; accessories intended for use with or installation upon picture projectors or intended to be employed in viewing, editing or handling films, slides, pictures, drawings, or similar stationary graphic material; cameras; chemical replenishers; contact printers; enlargers; exposure meters; film copiers, film cutters, film dryers; film editors; household film viewers; film and paper processors; film rewinders, film strip projectors; film strip projector-phonograph combinations; film strip projector-tape player combinations; motor-operated projector screens; silent and sound motion picture projectors; print dryers; print processors; printing easels; opaque projectors; overhead projectors; photoflash equipment; photographic timers; photometers, flash cameras; slide projectors; silver recovery units; slide projector-phonograph combinations; slide projector-tape player combinations; slide sorters; slide viewers; stripping and line-up tables; video printers; and similar equipment.

1.3 These requirements do not cover commercial film viewers and dark room safelights, which are evaluated under the requirements for fixtures and portable lamps; projector tables, which are evaluated under the requirements for utility tables; microfilm and micrographic equipment, which are evaluated under the requirements for office appliances and business equipment; or portable photographic lamps and floodlights, which are evaluated under the requirements for stage and studio lighting fixtures.

1.4 Electric photographic equipment intended for use in a hazardous location as defined in the National Electrical Code is evaluated on the basis of its compliance with the requirements in this standard, and other appropriate examination and tests to determine whether it is acceptable for the purpose.

1.5 A product that contains features, characteristics, components, materials, or systems new or different from those covered by the requirements in this standard, and that involves a risk of fire or of electric shock or injury to persons shall be evaluated using appropriate additional component and end-product requirements to maintain the level of safety as originally anticipated by the intent of this standard. A product whose features, characteristics, components, materials, or systems conflict with specific requirements or provisions of this standard does not comply with this standard. Revision of requirements shall be proposed and adopted in conformance with the methods employed for development, revision, and implementation of this standard.

1.5 revised July 11, 2001

## 2 General

### 2.1 Components

2.1.1 Except as indicated in 2.1.2, a component of a product covered by this standard shall comply with the requirements for that component. See Appendix A for a list of standards covering components generally used in the products covered by this standard.

2.1.2 A component is not required to comply with a specific requirement that:

- a) Involves a feature or characteristic not required in the application of the component in the product covered by this standard, or
- b) Is superseded by a requirement in this standard.

2.1.2 revised July 11, 2001

2.1.3 A component shall be used in accordance with its rating established for the intended conditions of use.

2.1.3 revised July 11, 2001

2.1.4 Specific components are incomplete in construction features or restricted in performance capabilities. Such components are intended for use only under limited conditions, such as certain temperatures not exceeding specified limits, and shall be used only under those specific conditions.

2.1.4 revised July 11, 2001

### 2.2 Units of measurement

2.2.1 Values stated without parentheses are the requirement. Values in parentheses are explanatory or approximate information.

2.2.1 revised July 11, 2001

### 2.3 Undated references

2.3.1 Any undated reference to a code or standard appearing in the requirements of this standard shall be interpreted as referring to the latest edition of that code or standard.



### 3 Terminology

3.1 In the following text, a requirement that applies only to specific equipment is identified by a specific reference in that requirement to the equipment involved. Absence of such specific reference or use of the term appliance indicates that the requirement applies to all equipment covered by this standard.

3.2 The values specified for voltage, current, and power in these requirements are (rms) values unless otherwise specified.

### 4 Glossary

4.1 For the purpose of this standard the following definitions apply.

4.2 ACCESSIBLE – Able to be contacted by an accessibility probe.

4.2 added April 9, 1999

4.3 APPLIANCE – Utilization equipment that uses electrical energy for some function.

4.3 added April 9, 1999

4.4 AUTOMATICALLY CONTROLLED APPLIANCE – An appliance in which energization of a motor, solenoid, magnet, heating device, or a similar device, occurs without manual intervention; or, during any single predetermined cycle of operation, automatic changing of the mechanical load can reduce the speed of a motor sufficiently to reestablish starting-winding connections to the branch circuit. An appliance intended to be used in a commercial movie theater is considered to be automatically controlled.

4.5 CONTINUOUS-DUTY MOTOR – A motor that can operate unattended and under load under any normal conditions of use for 3 hours or more. A commercial film processor is considered to be a continuously operated appliance.

No Text on This Page

4.6 EXPOSED – Visible but not necessarily able to be contacted by an accessibility probe.

4.6 added April 9, 1999

4.7 FIELD-WIRING TERMINALS – A terminal to which a supply wire or other wire can be connected by an installer in the field, is a field-wiring terminal unless the wire is provided as part of the appliance and a pressure terminal connector, soldering lug, soldered loop, a crimped eyelet, or other means for making the connection is factory-assembled to the wire.

4.8 FUNCTIONAL INSULATION – The insulation required for proper functioning of the appliance and for basic protection against risk of electric shock.

4.9 HAND-SUPPORTED APPLIANCE – An appliance that, during normal operation, is completely supported by the user.

4.10 LEAKAGE AND ELECTRIC SHOCK CURRENT – All current or currents, including capacitively-coupled currents, that may be conveyed between exposed conductive surfaces of an appliance and ground or other exposed conductive surfaces of the appliance.

4.11 LIMITED PRIMARY CIRCUIT – Wiring and components that are conductively connected to the supply circuit for which available power is less than 50 watts determined in accordance with 30.4.2.

4.12 LINE VOLTAGE (PRIMARY) CIRCUITS – The wiring and components that are conductively connected to the supply circuit.

4.13 LIVE PARTS – Metal or other conductive parts that, in normal use, have a potential difference with respect to earth ground or any other conductive part.

4.14 LOW-VOLTAGE, LIMITED-ENERGY CIRCUIT – A circuit that complies with the requirements in Low-Voltage, Limited-Energy Circuits, Section 32.

4.15 PORTABLE APPLIANCE – An appliance that is:

- a) Cord-connected, battery-operated, or both;
- b) Intended to be transported for use at various locations; and
- c) Designed to be carried by hand or provided with integral casters, wheels, and similar parts, or a cart to make it mobile.

4.16 REMOTELY-CONTROLLED APPLIANCE – An appliance that is not within the sight of the operator at the location of the starting device. An appliance intended to be used in a commercial movie theater is considered to be remotely controlled.

4.17 RISK OF ELECTRIC SHOCK – The risk of injury to persons resulting from exposure to a part involving excessive leakage current or excessive shock current. See the Leakage Current and Shock Current Tests, Section 47.

4.18 SAFETY CIRCUIT – A primary or secondary circuit that is relied upon to reduce the risk of fire, electric shock, or injury to persons during normal operation of an appliance.

4.19 USER SERVICING – Any form of servicing that may be performed by personnel other than those who are trained to maintain the particular appliance. Some examples of user servicing are:

- a) Attaching an accessory by means of an attachment plug and a receptacle, or by means of other separable connectors.
- b) Clearing jammed film, prints, or slides.
- c) Resetting a circuit breaker; replacing a battery, a fuse, or a lamp that is accessible without the use of a tool; and, replacing a battery or a lamp likely to require frequent replacement – for example, a projection lamp regardless of whether a tool is required.
- d) Making a routine operating adjustment necessary to adapt the appliance for one of its intended functions.
- e) Routine cleaning of an optical component, such as a lens or a mirror.
- f) Changing solutions, and cleaning a solution tray, a film or print roller, a guide, or a similar part.

## **CONSTRUCTION**

### **5 Moisture Condensation**

5.1 In an appliance provided with a cold-water infeed, uninsulated live parts and electrical components not acceptably protected shall be located so that there shall be no collection of moisture on or flooding of such parts by condensed water vapor dripping from tanks, pipes, and similar parts.

### **6 Frame and Enclosure**

#### **6.1 General**

6.1.1 The enclosure of an appliance shall house all parts that may present a risk of fire, electric shock, or injury to persons. The enclosure or a portion of the enclosure may be an integral part of a component, a separate item, or all or part of the ultimate enclosure or outer cabinet.

6.1.2 Steel, aluminum, glass – heat-resistant, tempered, wired, or laminated – and equivalent material may be used for the overall enclosure of an appliance.

6.1.3 In addition to the factors specified in 6.1.4, an enclosure of sheet metal shall be evaluated with regard to its size, shape, and thickness, considering the intended use of the appliance.

6.1.4 Among the factors to be considered in evaluating an enclosure are its:

- a) Mechanical strength,
- b) Resistance to impact,
- c) Moisture-absorptive properties,
- d) Combustibility,
- e) Resistance to corrosion, and

- f) Resistance to distortion at temperatures to which the enclosure may be subjected during normal or abnormal use.

For a nonmetallic enclosure, all of these factors are to be considered with regard to thermal aging.

6.1.5 The construction and intended use of the appliance is to be taken into account when evaluating the strength and rigidity of an enclosure. See the Strength of Enclosure Test, Section 58.

6.1.6 The frame and enclosure of an appliance shall have the strength and rigidity needed to resist the abuses to which it is likely to be subjected to during use. The degree of resistance inherent in the appliance shall preclude total or partial collapse with the attendant reduction of spacings, loosening or displacement of parts, and other serious defects that alone or in combination constitute an increase in the risk of fire, electric shock, or injury to persons.

6.1.7 The enclosure of an appliance shall be complete. No dependence shall be placed on an adjacent wall or adjacent equipment to complete an enclosure.

6.1.8 In evaluating the acceptability of the bottom of a portable appliance, consideration shall be given to the possibility of the appliance being placed on an object that could damage wiring or other electrical components. See 58.1.1 and 58.1.2.

## **6.2 Remotely- and automatically-controlled appliances**

6.2.1 The enclosure of a remotely or automatically controlled appliance, an appliance intended for operation unattended, or an appliance of which the operation or non-operation would not be evident to the operator, shall prevent molten metal, burning insulation, or flaming particles, from falling outside the enclosure, including the surface upon which the appliance rests or is otherwise supported.

6.2.2 The requirements in 6.2.1 necessitate the use of a barrier or pan of metal or equivalent material:

a) Under a motor unless:

- 1) The structural parts of the motor or of the appliance provide the equivalent of such a barrier;
- 2) The overcurrent protection provided with the motor is such that no burning insulation or molten material falls to the surface that supports the appliance when the motor is energized under each of the following fault conditions.
  - i) Open main winding;
  - ii) Open auxiliary windings;
  - iii) Starting switch short-circuited; and
  - iv) Capacitor of a permanent-split-capacitor motor short-circuited – the short-circuit is to be applied before the motor is energized, and the rotor is to be locked;
- 3) The motor mounted as intended in the appliance is provided with a thermal motor protector that prevents the temperature of the motor windings from exceeding 125°C (257°F) under the maximum load under which the motor runs without causing the protector to cycle, and from exceeding 150°C (302°F) with the rotor of the motor locked; or

4) The motor complies with the Standard for Overheating Protection for Motors, UL 2111, and the temperature of the motor winding does not exceed 150°C during the first 72 hours of operation with the motor mounted as intended in the appliance and the rotor of the motor locked;

b) Under a fuse, a switch, a relay, a solenoid, a transformer, or similar devices, unless it can be shown that malfunction of the component would not result in a risk of fire.

6.2.3 The barrier specified in 6.2.2 shall be:

a) Horizontal or constructed to provide equivalent protection;

b) Located as indicated in Figure 6.1; and

c) Not smaller in area than is indicated in Figure 6.1.

Openings for drainage, ventilation, and similar openings, shall be used in the barrier if the openings are protected by a baffle or similar protection so that molten metal or burning insulation cannot fall outside the enclosure.

### 6.3 Enclosure material

6.3.1 An enclosure of material having an exposed surface area greater than 10 square feet (0.93 m<sup>2</sup>) or a single dimension larger than 6 feet (1.83 m) shall have either:

a) A flame-spread rating of 200 or less when tested in accordance with the Standard for Tests for Surface Burning Characteristics of Building Materials, UL 723, or

*Exception: A material with a flame-spread rating higher than 200 is acceptable as the exterior finish or covering on any portion of the enclosure if the flame-spread rating of the combination of the base material and finish or covering is 200 or less.*

b) A flame-spread index of 100 or less when tested in accordance with the radiant-panel furnace methods in the Test Method for Surface Flammability of Materials Using A Radiant Heat Energy Source, ASTM E162.

*Exception No. 1: If all specimens of the thinnest wall section do not exhibit flame propagation, flaming particles, or flaming drops, the flame-spread index for any specimen shall not exceed 200.*

*Exception No. 2: If any specimen of the thinnest wall section exhibits flame propagation but does not exhibit flaming particles or drops, the flame-spread index for any specimens shall not exceed 150.*

6.3.2 The size limits specified in 6.3.1 refer to the exposed surface area of a single unbroken section. If two sides of a single piece are exposed, only the larger side is to be considered in computing the area.

6.3.3 Cast metal and sheet metal portions of the enclosure shall not be thinner than the applicable value specified in Table 6.1.

*Exception: The thickness may be less than the value specified in Table 6.1 if investigated in accordance with the Strength of Enclosure Test, Section 58, and determined to be acceptable for the application as indicated in 6.1.1 – 6.1.7.*

**Figure 6.1**  
**Location and extent of barrier**

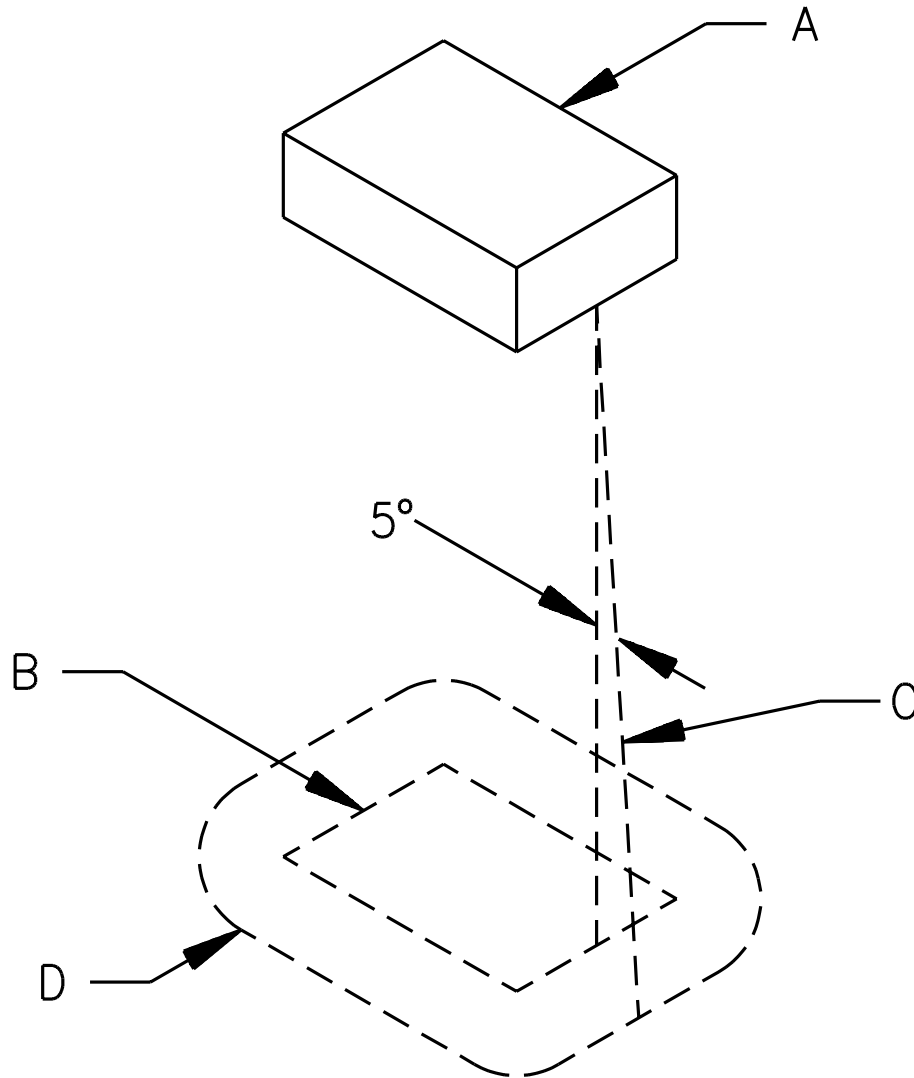

SA0604-1

A – Region to be shielded by barrier. This will consist of the entire component if it is not otherwise shielded, and will consist of the unshielded portion of a component which is partially shielded by the component enclosure or equivalent.

B – Projection of outline of component on horizontal plane.

C – Inclined line which traces out minimum area of barrier. When moving, the line is always (1) tangent to the component, (2) five degrees from the vertical, and (3) so oriented that the area traced out on a horizontal plane is maximum.

D – Location (horizontal) and minimum area for barrier. The area is that included inside the line of intersection traced out by the inclined line C and the horizontal plane of the barrier.

**Table 6.1**  
**Thickness of metal for enclosures**

Metal	Minimum thickness,	
	inch	(mm)
Die-cast	3/64	1.2
Cast malleable iron	1/16	1.6
Other cast metal	3/32	2.4
Uncoated sheet steel	0.032	0.81
Galvanized sheet steel	0.034	0.86
Sheet aluminum	0.044	1.12
Sheet copper and brass	0.043	1.09

6.3.4 A polymeric enclosure or a polymeric part of an enclosure employed on an appliance to reduce the risk of fire or electric shock shall comply with the Standard for Polymeric Materials – Use in Electrical Equipment Evaluations, UL 746C.

*Exception: The enclosure of a photoflash unit that is powered only by batteries or a power supply not exceeding low-voltage, limited-energy levels, is not required to meet the flame resistance requirements in the Standard for Polymeric Materials – Use in Electrical Equipment Evaluations, UL 746C, but shall comply with the requirements for classifying materials as HB, V-0, V-1, or V-2 in the Standard for Tests for Flammability of Plastic Materials for Parts in Devices and Appliances, UL 94.*

6.3.4 revised April 9, 1999

6.3.5 If openings for ventilation are provided in the enclosure of a permanently connected appliance, they shall be located so that they will not vent into concealed spaces of a building structure, such as into false-ceiling space, into hollow spaces in the wall, and the like, when the appliance is installed as intended.

6.3.6 During user servicing of household and commercial appliances, electrical parts of an appliance shall be located or enclosed to reduce the risk of electric shock.

## 7 Accessibility of Live Parts

### 7.1 Openings

7.1.1 If a marking draws attention of the user to a hole of any size in the enclosure for the adjustment of a thermostat or for a similar activity, it shall not be possible to damage insulation or contact uninsulated parts involving a risk of electric shock through the hole with a 1/16 inch (1.6 mm) diameter rod.

7.1.2 To reduce the risk of unintentional contact that may involve a risk of electric shock from an uninsulated live part or film-coated wire, an opening in an enclosure shall comply with either (a) or (b).

- a) For an opening that has a minor dimension (see 7.1.6) less than 1 inch (25.4 mm), such a part or wire shall not be contacted by the probe illustrated in Figure 7.1.



- b) For an opening that has a minor dimension of 1 inch or more, such a part or wire shall be spaced from the opening as specified in Table 7.1.

*Exception: A motor other than one used in either a hand-held product or a hand-supported portion of a product is not required to comply with these requirements if it complies with the requirements in 7.1.3.*

7.1.3 With regard to a part or wire as mentioned in 7.1.2, in an integral enclosure of a motor as mentioned in the Exception to 7.1.2:

- a) An opening that has a minor dimension (see 7.1.6) less than 3/4 inch (19.1 mm) is not acceptable if:
- 1) A moving part can be contacted by the probe illustrated in Figure 7.2;
  - 2) Film-coated wire can be contacted by the probe illustrated in Figure 7.3;
  - 3) In a directly accessible motor (see 7.1.7), an uninsulated live part can be contacted by the probe illustrated in Figure 7.4; and
  - 4) In an indirectly accessible motor (see 7.1.7), an uninsulated live part can be contacted by the probe illustrated in Figure 7.2.
- b) An opening that has a minor dimension of 3/4 inch or more is acceptable if a part or wire is spaced from the opening as specified in Table 7.1.

7.1.4 The probes mentioned in 7.1.2 and 7.1.3 and illustrated in Figures 7.1 – 7.4 shall be applied to any depth that the opening will permit; and shall be rotated or angled before, during, and after insertion through the opening to any position that is necessary to examine the enclosure. The probes illustrated in Figure 7.1 and 7.4 shall be applied in any possible configuration; and when required, the configuration shall be changed after insertion through the opening.

7.1.5 The probes mentioned in 7.1.4 and 7.1.6 shall be used as measuring instruments to evaluate the accessibility provided by an opening, and not as instruments to judge the strength of a material; they shall be applied with the minimum force necessary to determine accessibility.

7.1.6 With reference to the requirements in 7.1.2 and 7.1.3, the minor dimension of an opening is the diameter of the largest cylindrical probe having a hemispherical tip that can be inserted through the opening.

7.1.7 With reference to the requirements in 7.1.3, an indirectly accessible motor is a motor that is:

- a) Accessible only by opening or removing a part of the outer enclosure, such as a guard or panel that can be opened or removed without using a tool or
- b) Located at such a height or is otherwise guarded or enclosed so that it is unlikely to be contacted.

A directly accessible motor is a motor that can be contacted without opening or removing any part or is located so as to be accessible to contact.

7.1.8 During the examination of a product to determine whether it complies with the requirements in 7.1.2 or 7.1.3, a part of the enclosure that may be opened or removed by the user without using a tool (to attach an accessory, to make an operating adjustment, or for other reasons) is to be opened or removed.

Figure 7.1  
Articulate probe with web stop

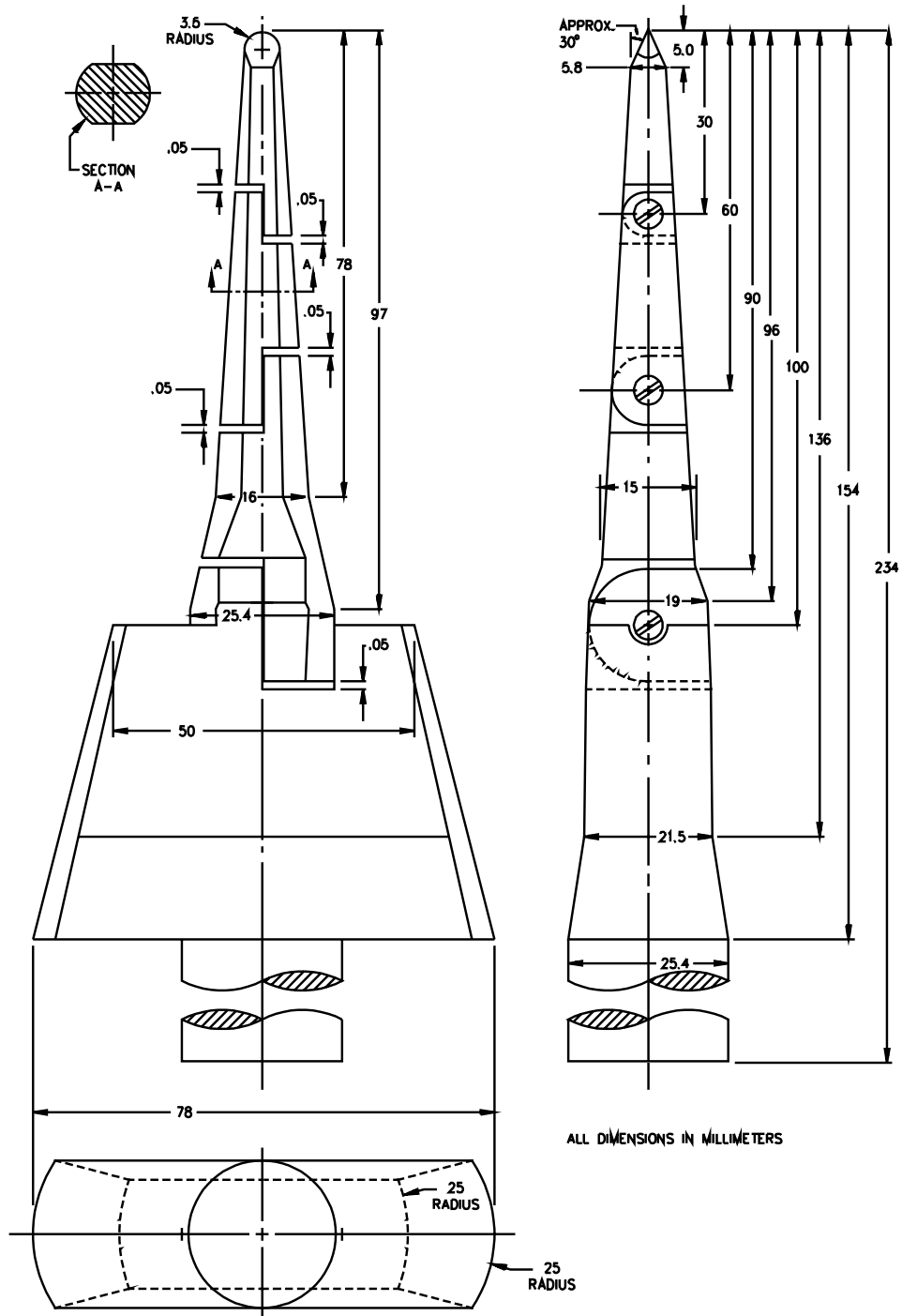

PA100A

**Table 7.1**  
**Minimum distance from an opening to a part that may involve a risk of electric shock or injury to persons**

Minor dimension <sup>a</sup> of opening,		Minimum distance from opening to part	
inches	(mm)	inches	(mm) <sup>b</sup>
3/4 <sup>c</sup>	19.1	4-1/2	114
1 <sup>c</sup>	25.4	6-1/2	165
1-1/4	31.8	7-1/2	190
1-1/2	38.1	12-1/2	318
1-7/8	47.6	15-1/2	394
2-1/8	54.0	17-1/2	444
d	d	30	762

<sup>a</sup> See 7.1.6.  
<sup>b</sup> Between 3/4 and 2-1/8 inches, interpolation is to be used to determine a value between values specified in the table.  
<sup>c</sup> Any dimension less than 1 inch applies to a motor only.  
<sup>d</sup> More than 2-1/8 inches, but not more than 6 inches (152 mm).

**Figure 7.2**  
**Probe No. 2**

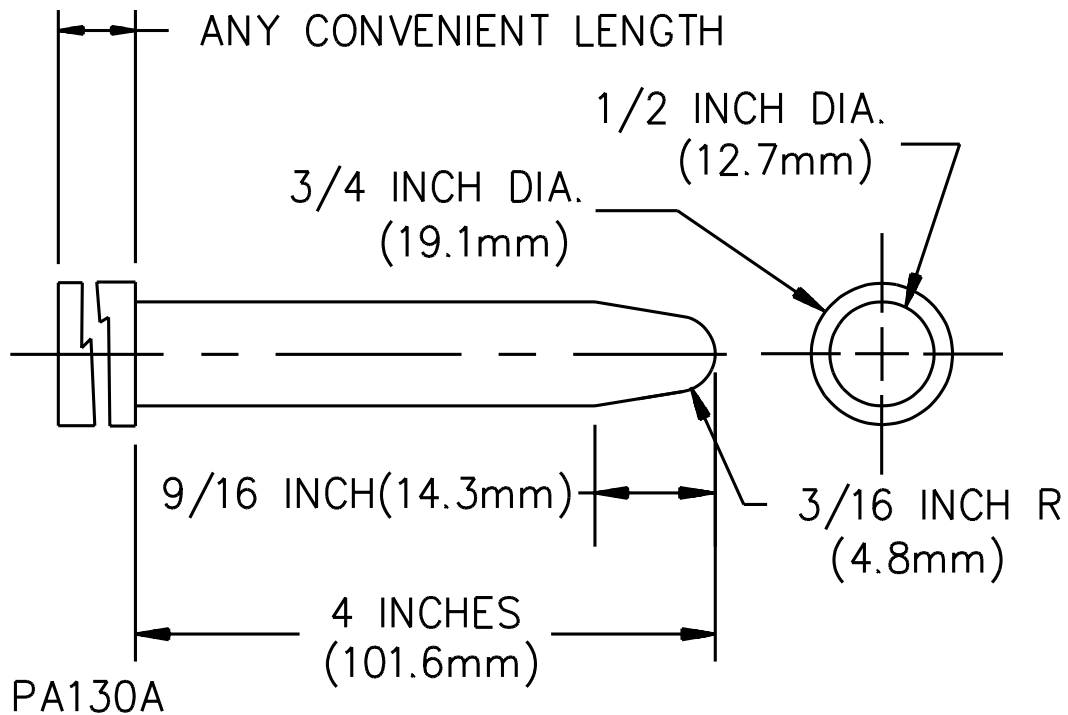

Figure 7.3  
Probe No. 3

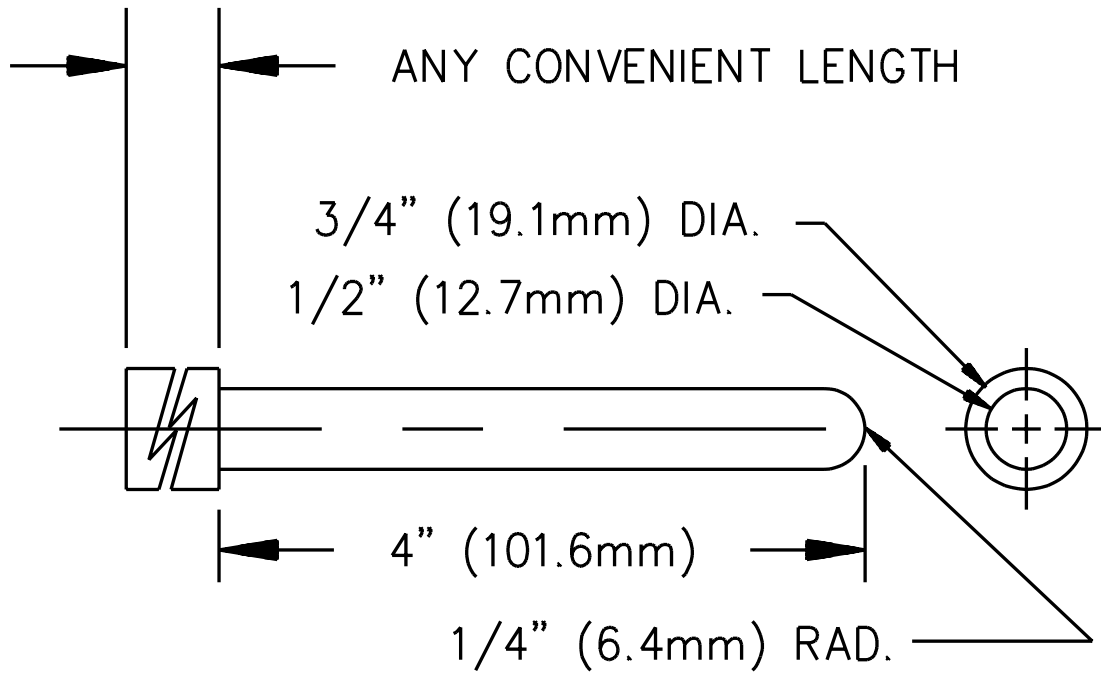
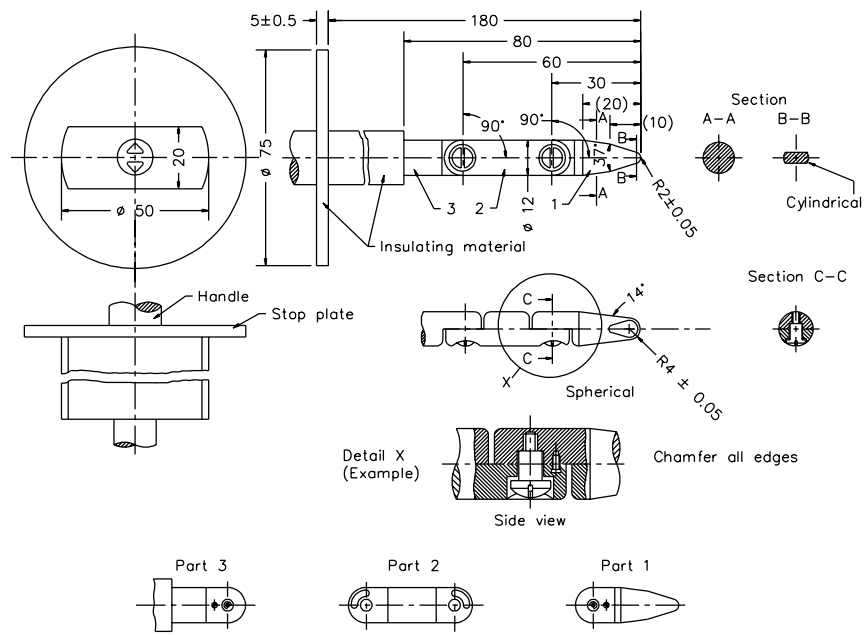

Figure 7.4  
Articulate probe

Figure 7.4 revised April 9, 1999



7.1.9 If the instructions indicate the use of a tool for the user to remove some portion of the enclosure to perform a function, then that portion of the enclosure is to be opened or removed to evaluate the accessibility of live parts.

Added 7.1.9 effective April 9, 2000

7.1.10 With reference to the requirements in 7.1.2 and 7.1.3, insulated brush caps are not required to be additionally enclosed.

7.1.11 If an interlock is provided to reduce the risk of contact with parts involving a risk of electric shock, the interlock shall comply with the requirements in Marking, Section 44.

## 7.2 Pin terminals

7.2.1 Pin terminals that involve a risk of electric shock shall be guarded or recessed to reduce the risk of a pin from being contacted unintentionally by persons while the cord-connector or plug is fully seated or is being removed from or placed on the pins. The guard or recess is to be evaluated as described in 7.2.2 and 7.2.3.

7.2.2 With no plug or cord-connector on the pins, a straightedge placed in any position across and in contact with the guard or recess shall not touch any pin.

7.2.3 With the contact openings in the cord-connector aligned with the pins, and with the face of the plug or connector located in the plane perpendicular to the end of the farthest projecting pin, it shall not be possible by means of a probe, illustrated in Figure 7.1 to touch any pin.

7.2.4 The plug specified in 7.2.1 is to be either:

- a) A standard flatiron or appliance plug if the pins on the appliance are of standard flatiron- or appliance-plug configuration or
- b) The plug supplied with the appliance, if the pins on the appliance are not of a standard flatiron- or appliance-plug configuration.

## 8 Mechanical Assembly

8.1 An appliance shall be assembled so that it will not be affected adversely by vibration during its intended operation.

8.2 Properly tightened screws, with or without a lock washer, and staked and upset screws are considered not subject to loosening.

8.3 A switch, fuseholder, lampholder, attachment-plug receptacle, motor-attachment plug, or similar device, shall be securely mounted and prevented from turning or shifting in position, if such motion results in a reduction of spacings below the applicable values specified in Spacings, Section 30.

*Exception: A switch or lampholder is not required to be mounted as specified if they comply with the requirements in 8.4 and 8.5.*

8.4 The requirement that a switch be prevented from turning may be waived if all four of the following conditions are met:

- a) The switch is of a plunger, slide, or other type that does not tend to rotate when operated. A toggle switch is considered to be subject to forces that tend to turn the switch during intended operation of the switch.

- b) The means of mounting the switch makes it unlikely that operation of the switch will loosen the switch.
- c) Spacings are not reduced below the applicable values if the switch rotates.
- d) Intended operation of the switch is by mechanical means rather than by direct contact by persons.

8.5 A lampholder of a type in which the lamp cannot be replaced – such as a neon pilot or an indicator light in which the lamp is sealed in a nonrenewable jewel – is not required to be prevented from turning if:

- a) Rotation does not reduce spacings below the applicable values and
- b) Such rotation does not cause stress to be transmitted to terminal connections.

8.6 Means for preventing the turning described in 8.3 shall consist of more than friction between surfaces – for example, a lock washer, properly applied, is acceptable as a means to prevent turning of a device having a single-hole mounting means.

## 9 Protection Against Corrosion

9.1 Iron and steel parts shall be protected against corrosion or damage from chemicals, such as fixing solution, by painting, galvanizing, plating, or other equivalent means if the breakdown of such unprotected parts would be likely to result in a risk of fire, electric shock, or injury to persons during the intended operation of the appliance.

*Exception No. 1: In certain equipment where the oxidation of steel is not likely to be accelerated due to the exposure of metal to air, moisture, and other oxidizing influence – thickness of metal and temperature also being factors – surfaces of sheet steel in an enclosure may not be required to be protected against corrosion.*

*Exception No. 2: Cast iron parts, bearings, laminations, and minor parts of iron or steel, such as washers and screws, are not required to be protected against corrosion.*

## 10 Power Supply Connections

### 10.1 Cord-connected appliances

#### 10.1.1 Cords and plugs

10.1.1.1 A cord-connected appliance shall be provided with a length of flexible cord and an attachment plug for connection to a power-supply circuit. The flexible cord shall:

- a) Be either attached permanently to the appliance or be in the form of a separate cord set with means for connection to the appliance;
- b) Be Type SJ, SJE, SJT, or harder service cord for commercial appliances;

*Exception: A commercial appliance that is intended to be moved frequently may be supplied with Type SP-2, SPE-2, SPT-2, SV, SVE, or SVT cord.*

c) Be Type SP-2, SPE-2, SPT-2, SV, SVE, SVT, or harder service cord for household appliances; and

d) Have a current and voltage rating not less than that of the appliance.

10.1.1.1 revised April 9, 1999

10.1.1.2 A cord shall be oil-resistant if the equipment is likely to be subjected to grease or oil.

10.1.1.3 The length of the power-supply cord is to be measured from the face of the attachment plug to the point where the cord emerges from the appliance. The length of:

a) Type SP-2, SPE-2, SPT-2, SV, SVE, or SVT cord shall be 6 – 12 feet (1.83 – 3.66 m) for a household appliance and 6 – 10 feet (1.83 – 3.05 m) for a commercial appliance and

b) Type SJ, SJE, SJT, or harder service cord shall not be less than 6 feet (1.83 m) long.

*Exception: Photoflash/power-supply combinations may be provided with a power-supply cord not less than 18 inches (457 mm) long if the total length of the power-supply cord plus the interconnecting cord to the photoflash enclosure is not less than 6 feet. See Table 14.1.*

10.1.1.4 The voltage and current ratings of the attachment plug shall not be less than those of the appliance. The current rating of the attachment plug – and of the cord-connector if a cord set is used – of an appliance rated more than 15 A shall not be less than 125 percent of the current rating of the appliance if the load will constitute a continuous load – 3 hours or more.

*Exception: A 20-A attachment plug and cord-connector are acceptable for an appliance rated not more than 4000 watts at 240 V.*

10.1.1.5 The attachment plug of the power-supply cord of an appliance provided with a 15- or 20-A general-use receptacle shall be of the 3-wire grounding type.

Added 10.1.1.5 effective April 9, 2000

10.1.1.6 The attachment plug of the power-supply cord of an appliance provided with either a manually operated, line-connected, single-pole switch for an appliance on/off operation, or an Edison-base lampholder shall be of the 2-wire polarized or 3-wire grounding type.

Added 10.1.1.6 effective April 9, 2000

10.1.1.7 If a 3-wire grounding-type attachment plug or a 2-wire polarized attachment plug is provided, the attachment plug connections shall comply with Figure 10.1 and the polarity identification of the flexible cord shall comply with Table 10.1.

Added 10.1.1.7 effective April 9, 2000

10.1.1.8 The conductor of the power-supply cord that is intended to be grounded shall have the following items connected to it: the screw shell of an Edison-base lampholder and the terminal or lead of a receptacle intended to be grounded. Table 10.1 identifies the supply cord conductor intended to be grounded.

Added 10.1.1.8 effective April 9, 2000

**Figure 10.1**  
**Connection to attachment plugs**

Added Figure 10.1 effective April 9, 2000

CONNECTIONS OF CORD CONDUCTORS TO GROUNDING – TYPE  
 ATTACHMENT PLUG (FACE OF PLUG REPRESENTED)

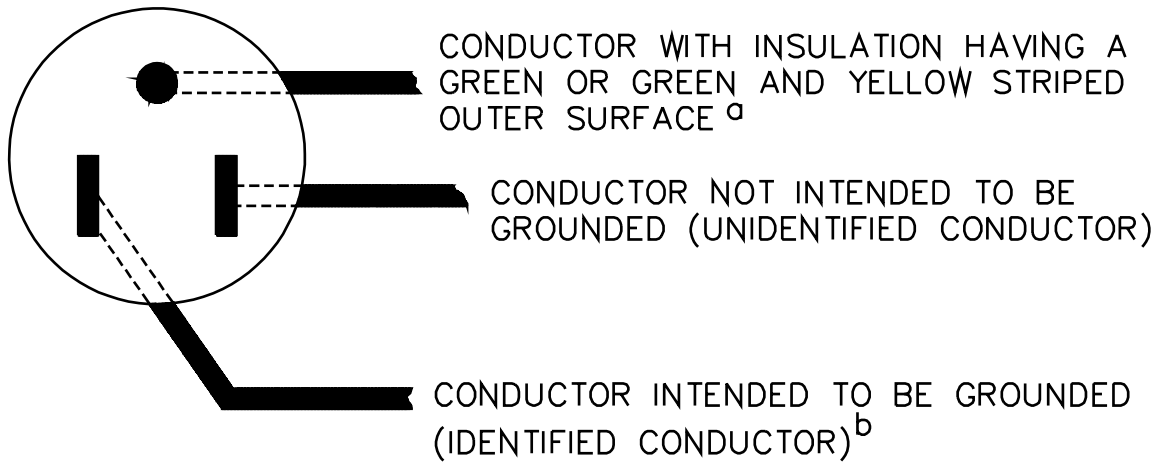

CONNECTIONS OF CORD CONDUCTORS TO POLARIZED  
 ATTACHMENT PLUG (FACE OF PLUG REPRESENTED)

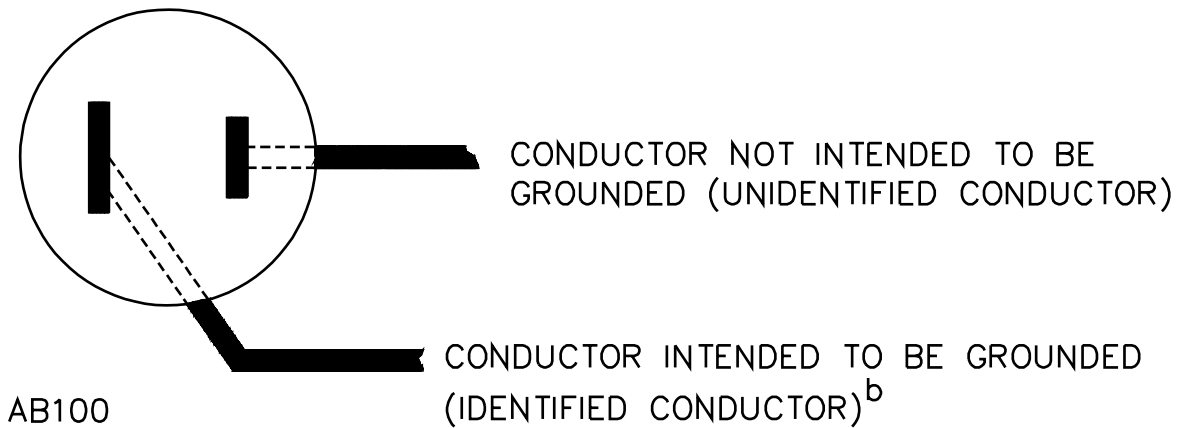

<sup>a</sup> The blade to which the green conductor is connected may have a U-shaped or circular cross section.

<sup>b</sup> Signifies a conductor identified in accordance with Table 10.1.



**Table 10.1**  
**Polarity identification of flexible cords**

Added Table 10.1 effective April 9, 2000

Method of identification		Acceptable combinations	
		Wire intended to be grounded <sup>a</sup>	All other wires <sup>a</sup>
Color of braids on individual conductors	A	Solid white or natural gray – without tracer	Solid color other than white or natural gray – without tracer
	B	Color other than white or natural gray, with tracer in braid	Solid color other than white or natural gray – without tracer
Color of insulation on individual conductors	C <sup>b</sup>	Solid white or natural gray	Solid color other than white or natural gray
	C1 <sup>c</sup>	Light blue	Solid color other than light blue, white, or natural gray
Color of separators	D <sup>d</sup>	White or natural gray	Color other than white or natural gray
Other means	E <sup>e</sup>	Tin or other white metal on all strands of the conductor	No tin or other white metal on the strands of the conductor
	F <sup>d</sup>	A stripe, ridge, or groove on the exterior surface of the cord	
<sup>a</sup> A wire finished to show a green color with or without one or more yellow stripes or tracers is to be used only as an equipment grounding conductor. See 10.1.1.9 and Figure 10.1. <sup>b</sup> Only for cords – other than Types SP-1, SP-2, and SPT-1 – having no braid on any individual conductor. <sup>c</sup> For jacketed cord. <sup>d</sup> Only for Types SP-1, SP-2, SPT-1, and SPT-2 cords. <sup>e</sup> Only for Types SPT-1 and SPT-2 cords.			

10.1.1.9 If a polarized attachment plug is used, a fuseholder, a single pole overcurrent protective device other than an automatic control without a marked off position, the center contact of an Edison-base lampholder, an interlock and a single pole manual on-off switch with a marked off position shall be connected to the ungrounded side of the line when used in the primary circuit.

*Exception: An appliance intended for 120-volt operation may have both sides of the line fused if required to comply with a federal specification for shipboard usage.*

10.1.1.10 The attachment plug provided with a dual-rated appliance shall be acceptable for the voltage that the appliance is intended to be connected when shipped from the factory. The supply cord – and the cord-connector if a cord set is used – shall have a voltage rating and ampacity acceptable for operation at all available voltage settings. See 66.2.1.

10.1.1.11 A household appliance intended for use with a detachable cord set shall not be provided with pin terminals that accommodate a standard flatiron or appliance plug, but may be provided with a specific-purpose flatiron or appliance plug. See 7.2.1 – 7.2.4.

10.1.1.12 Only one supply circuit shall be provided to connect an appliance to the primary circuit power.

*Exception: More than one supply circuit may be provided if:*

- a) More than one voltage or kind of power is required – for example, 3-phase and 1-phase, regulated and unregulated, AC and DC;*
- b) The function of the unit is intended to be extended or reduced at a later date; or*
- c) Redundant power supply sources are necessary.*

10.1.1.13 If more than one supply cord is provided on an appliance, the construction shall be such that disconnection of any one power-supply cord will automatically de-energize all circuits within the appliance.

*Exception No. 1: A cord that remains connected, a terminal strip or circuit breaker, if used, and a part of a unit on the line side of a disconnect device may remain energized if they are enclosed or otherwise protected against unintentional contact by service personnel performing service functions not involving these parts.*

*Exception No. 2: If a legible and durable marking is provided at the main disconnect device for each primary-circuit-power source clearly indicating the number of power-supply sources for the unit and providing complete instructions for disconnecting all power circuits that involve a risk of electric shock. See 67.1.3.*

## 10.1.2 Strain relief

10.1.2.1 The power-supply cord shall be attached to the appliance so that a mechanical strain applied on the cord leaving the overall enclosure in accordance with the Strain Relief Test, Section 59, cannot:

- a) Be transmitted to terminals, splices, or internal wiring;
- b) Separate an interlock connector from the part of the appliance to which it is attached; and
- c) Damage an interlock so that it does not perform its intended function.

## 10.1.3 Push-back relief

10.1.3.1 Means shall be provided to prevent the flexible cord from being pushed into the appliance through the cord-entry hole if such displacement can result in:

- a) Mechanical damage to the cord;
- b) Exposure of the cord to a temperature higher than that for which it is intended;
- c) Reduction of spacings – such as to a metal strain relief attachment – below the applicable values; or
- d) Stress on an internal wiring connection. See the Cord and Cable Push-Back Relief Test, Section 60.

10.1.3.1 revised April 9, 1999

#### 10.1.4 Bushings

10.1.4.1 At a point where a flexible cord passes through an opening in a wall, a barrier, or an enclosing case, there shall be a bushing or the equivalent that shall be secured in place, and shall have a smooth, rounded surface against which the cord may bear. An insulating bushing shall be provided if:

- a) Type SP-2, SPE-2, SPT-2, or other cord not having a jacket is employed;
- b) The wall or barrier is of metal; or
- c) The construction is such that the cord may be subjected to stress or motion.

10.1.4.2 If the hole through which the cord passes is in porcelain, phenolic composition, or similar nonconducting material, a smooth, well-rounded surface is considered equivalent to a bushing.

10.1.4.3 Ceramic materials and some molded compositions, such as phenolic, nylon, polyethylene, and the like, are generally acceptable for insulating bushings, but a bushing of wood is not acceptable.

10.1.4.4 Vulcanized fiber may be employed for a bushing that is not less than 3/64 inch (1.2 mm) thick and is formed and secured in place so that it will not be affected adversely by moisture, as determined by testing in accordance with 59.2.

10.1.4.5 A bushing of the same material and molded integrally with the power-supply cord is acceptable on a Type SP-2 or harder service cord if the built-up section is not less than 1/16 inch (1.6 mm) thick at the point where the cord passes through the enclosure.

10.1.4.6 An insulated metal grommet may be accepted in place of an insulating bushing if the insulating material used is not less than 1/32 inch (0.8 mm) thick and completely fills the space between the grommet and the metal in which the grommet is mounted.

### 10.2 Permanently-connected appliances

#### 10.2.1 General

10.2.1.1 An appliance intended for permanent connection to the power supply shall have provision for connection of one of the wiring systems in accordance with the National Electrical Code, ANSI/NFPA 70.

*Exception: An appliance in which the fastening means and mechanical connections are intended to permit frequent removal for interchange, maintenance, or repair may be provided with 2 – 8 feet (0.6 – 2.44 m) of Type S, SO, ST, or STO cord terminating in an attachment plug.*

10.2.1.2 A terminal box or compartment in which power-supply connections to a permanently-connected appliance are intended to be made shall be located so that these connections may be readily inspected after the appliance is installed as intended.

10.2.1.3 Wiring space or other compartments intended to enclose wires shall be free of any sharp edge, burr, fin, moving part, or similar hazard, that can damage the conductor insulation.

10.2.1.4 A terminal compartment intended for connection of a supply raceway shall be attached to the appliance so as to be prevented from turning.

## 10.2.2 Wiring terminals and leads

10.2.2.1 A permanently-connected appliance shall be provided with leads or wiring terminals for the connection of conductors having an ampacity, in accordance with the National Electrical Code, ANSI/NFPA 70, acceptable for the appliance.

10.2.2.2 A terminal solely for connection of an equipment-grounding conductor shall be capable of securing a conductor of the size acceptable for the particular application, in accordance with the National Electrical Code, ANSI/NFPA 70.

10.2.2.3 A wiring terminal shall be provided with a soldering lug or pressure terminal connector securely fastened in place; for example, firmly bolted or held by a screw.

*Exception: A wire-binding screw may be employed at a wiring terminal intended to accommodate a No. 8 AWG (8.4 mm<sup>2</sup>) or smaller conductor if upturned lugs or the equivalent are provided to hold the wire in position.*

10.2.2.4 A wiring terminal shall be prevented from turning.

10.2.2.5 The free length of a lead inside an outlet box or wiring compartment shall be 6 inches (152 mm) or more if the lead is intended for field connection to an external circuit.

*Exception: The lead may be less than 6 inches long if it is evident that the use of the longer lead might result in a risk of fire or electric shock.*

10.2.2.6 A lead intended for the connection of an equipment-grounding conductor shall not be smaller than the supply conductors.

## 10.2.3 Wire-binding screws

10.2.3.1 A wire-binding screw at a wiring terminal shall not be smaller than No. 10.

*Exception: A No. 8 screw may be used at a terminal intended only for the connection of a No. 14 AWG (2.1 mm<sup>2</sup>) conductor, and a No. 6 screw may be used for the connection of a No. 16 AWG (1.3 mm<sup>2</sup>) or No. 18 AWG (0.82 mm<sup>2</sup>) conductor. See 10.2.3.4.*

10.2.3.2 It should be noted that, according to the National Electrical Code, ANSI/NFPA 70, No. 14 AWG (2.1 mm<sup>2</sup>) is the smallest conductor that may be used for branch-circuit wiring, and thus is the smallest conductor that may be anticipated at a terminal for connection of a power-supply wire.

10.2.3.3 A wire-binding screw shall thread into metal. A terminal plate tapped for a wire-binding screw shall be metal not less than 0.050 inch (1.27 mm) thick and shall not have less than two full threads in the metal.

*Exception: An alloy plate not less than 0.030 inch (0.76 mm) thick may be used if the tapped threads have acceptable mechanical strength.*

10.2.3.4 A terminal plate formed from stock having the required thickness, as specified in 10.2.3.3 may have the metal extruded at the tapped hole to provide two full threads for the binding screw.

10.2.3.5 Upturned lugs or a cupped washer shall be capable of retaining a supply conductor of the size indicated in 10.2.2.1 under the head of the screw or washer.

## 10.2.4 Identification

10.2.4.1 A permanently-connected appliance rated 125 V; or 125/250 V, 3-wire, or less; and employing an Edison-base lampholder, or a single-pole switch or overcurrent-protective device rather than an automatic control without a marked off position, shall have one terminal or lead identified for the connection of the grounded conductor of the supply circuit. The terminal or lead intended to be grounded shall be the one that is electrically connected to the screw shell of a lampholder and to which no switch or overcurrent protective device of the single-pole type other than an automatic control without a marked off position is connected.

10.2.4.2 A terminal intended for the connection of a grounded supply conductor shall either:

- a) Be made of, or plated with, metal that is substantially white in color and shall be readily distinguishable from the other terminal or
- b) Have proper identification clearly shown in some other manner, such as on attached wiring diagram.

10.2.4.3 A lead intended for the connection of a grounded power-supply conductor shall be finished to show a white or natural gray color and shall be readily distinguishable from the other leads.

10.2.4.4 The surface of an insulated lead intended solely for the connection of an equipment-grounding conductor shall be green with or without one or more yellow stripes, and no other lead shall be so identified.

10.2.4.5 A wire-binding screw intended for the connection of an equipment-grounding conductor shall have a green-colored head that is either hexagonal, slotted, or both. A pressure terminal connector intended for connection of such a conductor shall be plainly identified, such as by being marked "G," "GR," "GND," "Ground," or the like, or by a marking on a wiring diagram provided on the appliance.

## 11 Current-Carrying Parts

11.1 A current-carrying part shall be of silver, copper, a copper-base alloy, stainless steel, aluminum, or equivalent material.

*Exception No. 1: Plated steel may be used for a secondary-circuit part; for some primary-circuit parts, such as a solder terminal and a capacitor terminal where a glass-to-metal seal is necessary; and for a lead or a threaded stud of a semiconductor device.*

*Exception No. 2: Blued steel or steel with equivalent resistance to corrosion is acceptable for the current-carrying contact arms of mechanically or magnetically operated leaf switches and within a motor and its governor – including the motor terminals – but not elsewhere.*

## 12 Internal Wiring

### 12.1 Mechanical protection

12.1.1 The wiring and connections between parts within an appliance shall be protected or enclosed.

12.1.2 Wiring is considered to be acceptably protected if it cannot be touched by the probe illustrated in Figure 7.3 for a commercial appliance, and the probe illustrated in Figure 7.1 for a household appliance, when the appliance is assembled as intended for normal operation or transport.

12.1.3 Internal wiring, including wires within an enclosure, a compartment, a raceway, or a similar part or housing, shall be routed and secured so that neither it nor related electrical connections are likely to be subjected to stress or mechanical damage resulting from contact with a rough, sharp, or moving part.

12.1.4 If user-servicing involves moving an assembly that has a wiring connection to another part of the appliance:

- a) Any wiring – other than an acceptable flexible cord – that involves a risk of electric shock and that may be handled during such servicing shall have supplementary insulation consisting of two thicknesses of tape or a length of 1/64 inch (0.4 mm) thick tubing or
- b) The appliance construction shall be such that the circuits are not energized during the servicing operation.

12.1.5 Wiring shall be located and secured so that during a user servicing operation, that involves removal and replacement of an object, contact with the wiring by the object or by the user is not likely.

12.1.6 If metal clamps and guides are used for routing stationary internal wiring, auxiliary nonconducting mechanical protection shall be provided where pressure is exerted on a conductor having thermoplastic insulation and no overall braid.

## 12.2 Types of wire

12.2.1 The internal wiring of an appliance shall consist of wires that are of a type or types having a flame-retardant rating (VW-1) and that are acceptable for the particular application, considered with regard to their exposure to oil or grease, and with regard to the temperature, voltage, and other conditions of service to which the wiring is likely to be subjected.

*Exception No. 1: Wiring used in low-voltage, limited-energy circuits are not required to be rated VW-1.*

*Exception No. 2: An integral lead of a component is not required to be rated VW-1.*

12.2.1 revised April 9, 1999

12.2.2 A conductor utilizing beads for insulation shall not be employed outside an enclosure.

## 12.3 Splices and connections

12.3.1 Each splice and connection shall be mechanically secure and shall provide reliable electrical contact. A soldered connection shall be made mechanically secure before being soldered if breaking or loosening of the connection may result in a risk of fire, electric shock, or injury to persons during intended operation of the appliance. Consideration shall be given to vibration, and similar movement, when evaluating the acceptability of electrical connections.

12.3.2 A lead is considered to be mechanically secure at a soldered connection if one or more of the following conditions are met:

- a) There is at least one full wrap around a terminal.
- b) Other than as specified in (c), there is at least one right-angle bend where the lead passes through an eyelet or opening.
- c) On a printed-wiring board, components are properly inserted and soldered.
- d) The lead is twisted with other conductors.

12.3.3 Tack soldering – placing a lead along a flat surface and soldering it – is not acceptable unless it can be demonstrated that a risk of fire, electric shock, or injury to persons during intended operation of the appliance does not exist with the lead detached.

12.3.4 A splice shall be provided with insulation equivalent to that of the wires involved if permanence of spacing between the splice and other metal parts is not maintained.

12.3.5 Insulation consisting of two layers of friction tape, or two layers of thermoplastic tape, or of one layer of friction tape wrapped over one layer of rubber tape is acceptable on a splice. In determining whether splice insulation consisting of coated-fabric, thermoplastic, or another type of tubing is acceptable, consideration shall be given to such factors as its dielectric properties, heat- and moisture-resistant characteristics, and similar characteristics. Thermoplastic tape wrapped over a sharp edge is not acceptable.

12.3.6 Stranded internal wiring terminations shall be made so that looser strands of wire are prevented from contacting other uninsulated live parts that are not always of the same polarity as the wire, and from contacting dead metal parts. This may be accomplished by use of a pressure terminal connector, a soldering lug, a crimped eyelet, soldering all strands of the wire together, or other means.

12.3.7 An aluminum conductor, insulated or uninsulated, used for internal wiring, such as for interconnection between current-carrying parts or as motor windings, shall be terminated at each end by a method acceptable for the combination of metals involved at the connection point.

12.3.8 With reference to 12.3.7, if a wire-binding screw construction, or a pressure terminal connector is used as a terminating device, it shall be acceptable for use with aluminum under the conditions involved; for example, temperature, heat cycling or vibration.

## 13 Grounding and Bonding

### 13.1 Grounding

13.1.1 Provision for grounding shall be provided for an appliance:

a) Intended to be used on a power-supply circuit operating at more than 150 V to ground. See 21.2.7.

b) Intended for use in a theater or motion picture studio.

*Exception: A double-insulated, cord-connected appliance is not required to be grounded.*

c) Involving the use of water in its operation.

d) Intended to be permanently connected.

13.1.2 If a means for grounding is provided on an appliance – even if it is not required by 13.1.1 – it shall comply with the requirements in 13.1.3 – 13.2.4 and Resistance of Grounding Circuit, Section 46.

13.1.3 The means for grounding shall be:

a) An equipment grounding conductor in the cord of a cord-connected appliance or

- b) A field-wiring terminal or pigtail lead provided in the equipment intended for permanent connection.

Revised 13.1.3 effective April 9, 2000

13.1.4 An equipment grounding conductor of a flexible cord shall be:

- a) Finished to show a green color with or without one or more yellow stripes; and
- b) Connected to the grounding member of an acceptable attachment plug having a fixed grounding contact.

13.1.5 The equipment grounding terminal or lead grounding point shall be connected to the frame or enclosure by a positive means, such as by a bolted or screwed connection. The grounding connection shall penetrate nonconductive coatings, such as paint or vitreous enamel. The grounding point shall be located so that it is unlikely that the grounding means will be removed during servicing not involving the grounding connection.

13.1.6 The securing means specified in 13.1.5 shall be of corrosion-resistant metal, such as stainless steel, or shall be protected against corrosion in a manner that will not inhibit electrical conductivity between the screw and any other conductor. If a screw is used, a lock washer or an equivalent means shall be employed to prevent the screw from becoming loosened by vibration.

13.1.7 If two or more appliances are electrically or mechanically connected to one another and one of them is grounded, each unit of the system that has a separate power-supply cord shall have a grounding conductor in the cord. If the appliances are interconnected electrically and one of them is grounded, they shall be bonded together; for example, by means of a discrete conductor included in an interconnecting cable. The size of the grounding conductor shall be at least the size of the supply conductors.

13.1.8 If a grounding means is provided on an appliance, all exposed dead metal parts and all dead metal parts within the enclosure that are exposed to contact during operator servicing and likely to become energized shall be connected to the grounding means.

13.1.9 The size of discrete conductors used for grounding shall be determined by the rating of the overcurrent protective device of the branch circuit to which the equipment will be connected. The size of the wiring to components mounted on or near the dead metal parts likely to become energized shall be in accordance with the table for Minimum Size Equipment Grounding Conductors for Grounding Raceway and Equipment in the National Electrical Code, ANSI/NFPA 70, but not smaller than No. 14 AWG (2.1 mm<sup>2</sup>).

*Exception: A conductor smaller than that specified in the NEC table may be used if the grounding connection does not open when tested as described in 46.3.*

Revised 13.1.9 effective April 9, 2000

13.1.10 All conductive parts that are accessible to service personnel and that are usually expected to be at ground potential (rubber-cushion-mounted motors, electronic chassis, and the like) but are likely to become energized by a single fault condition from a circuit involving risk of electric shock shall be connected to the grounding means, or a marking in accordance with 67.11.1 shall be provided.



13.1.11 With reference to the requirements in 13.1.8, the following dead metal parts are not considered likely to become energized:

- a) A small metal part – such as an adhesive-attached foil marking, a screw, a handle, or the like – that is on the exterior of the enclosure and separated from all electrical components by grounded metal or electrically isolated from all electrical components;
- b) A panel or a cover that is isolated from all electrical components by a barrier of vulcanized fiber, varnished cloth, phenolic composition, or other moisture-resistant insulating material not less than 1/32 inch (0.8 mm) thick;
- c) A panel or a cover that does not enclose uninsulated live parts and is electrically isolated from other electrical components; and
- d) A core and an assembly screw of a relay, a solenoid, or similar device.

## 13.2 Bonding

13.2.1 An appliance employing an enclosure of insulating material, either wholly or in part, shall have a bonding means that provides continuity of grounding between all conduit openings. The bonding means may be either completely assembled to the appliance or provided as separate parts for field installation. An appliance intended for field assembly of the bonding means shall be provided with complete instructions for proper installation. The instructions shall identify the parts involved and the proper method of installing them.

13.2.2 The continuity of the conduit system shall be a metal-to-metal contact not relying on the insulating-material enclosure in any manner other than as provided in 13.2.3. Bonding between the parts of the conduit system at all places where conduit may be connected shall be evaluated with the insulation material in place or removed. Tests are to be conducted at any ambient temperature within the range of 10 – 40°C (50 – 104°F).

13.2.3 With reference to 13.2.2, if the continuity of the grounding system relies on the integrity of a polymeric material, various samples shall be subjected to:

- a) Creep tests conducted at various oven-conditioning temperatures and
- b) Overcurrent tests conducted at 200 percent of the rated current of the branch-circuit-protective device.

13.2.4 Discrete conductors used for bonding shall equal or exceed the size of the wiring to components mounted on or near the dead metal parts likely to become energized.

*Exception: A conductor smaller than that specified in the table for Minimum Size Equipment Grounding Conductors for Grounding Raceway and Equipment in the National Electrical Code, ANSI/NFPA 70, may be used if the bonding connection does not open when tested as described in 46.3.*

Added 13.2.4 effective April 9, 2000

## 14 Interconnecting Cords and Cables

14.1 A flexible-cord or cable assembly used for external connections between sections of an appliance or between appliances shall be equivalent to, or acceptable for harder service than the power-supply cord.

*Exception No. 1: Type SV, SVE, SVT, SP-2, SPE-2, or SPT-2 flexible cord may be used for the connection of a remote control of a slide projector or a similar appliance if the cord is not longer than 12 feet (3.7 m).*

*Exception No. 2: Interconnecting cable for photoflash equipment shall be as specified in Table 14.1. An equivalent or harder cord may be used.*

*Exception No. 3: Cords or cables in low-voltage, limited-energy circuits are not required to comply.*

**Table 14.1**  
**Interconnecting cables for photo-flash equipment**

Table 14.1 revised April 9, 1999

Power supply <sup>a</sup>	Use	Voltage (rms)	Maximum length, feet	Cable type
Isolated	Commercial or household	600 or less	No limit	SJ, SJE, SJT
Isolated	Commercial	600 or less	5 <sup>b</sup>	SP-2, SPE-2, SPT-2, SV, SVE, SVT
Isolated	Household	600 or less	12 <sup>c</sup>	SP-2, SPE-2, SPT-2, SV, SVE, SVT
Isolated	Commercial or household	More than 600 <sup>d</sup>	No limit	S, SE, SO, ST
Isolated	Commercial or household	More than 600 <sup>d</sup>	5 <sup>b</sup>	SJ, SJE, SJT
Battery pack	Commercial or household	600 or less	5 <sup>b</sup>	SP-2, SPT-2, SV, SVE, SVT
Directly connected	Commercial	300 or less <sup>e</sup>	No limit	SJ, SJE, SJT
Directly connected	Household	300 or less <sup>e</sup>	12 <sup>c</sup>	SP-2, SPE, SPT-2, SV, SVE, SVT

<sup>a</sup> An isolated power supply is one that employs a transformer provided with a separate primary winding connected to the alternating-current power-supply circuit, and electrically isolated from all other windings.

<sup>b</sup> This 5-foot (1.52-m) limit normally prevents the cord from resting on the floor. Coiled cords or other constructions that are longer than 5 feet but are not likely to contact the floor are acceptable.

<sup>c</sup> This 12-foot (3.7-m) limit applies to portable photo-flash equipment that is intended to be directly or indirectly mounted – shoe or accessory bracket – to a camera. The 12-foot limit is measured between the face of the attachment plug and the cord entry hole on the flash enclosure. Accordingly, the maximum length may consist of the interconnecting cable only between a plug-in power supply and the flash enclosure or any combined lengths of the power-supply cord and the interconnecting cable.

<sup>d</sup> See 55.4.1 for dielectric voltage-withstand test.

<sup>e</sup> The voltage limit of 300 volts rms (424 volts peak) applies between conductors and between any conductor and earth ground.

14.2 A permanently attached cord or cable shall comply with the requirements in 10.1.2.1 – 10.1.4.6.

*Exception: Cords or cables in low-voltage, limited-energy circuits where strain relief is not required for segregation are not required to comply with the requirements in 10.1.2.1 – 10.1.4.6.*

14.3 When inserting a male connector in a female connector, other than the one intended to receive it, misalignment of male or female connectors and other manipulations of parts that are accessible to the operator shall not result in a risk of fire or electric shock.

14.4 An external cable shall not terminate in an accessible live contact.

14.5 An interlock circuit used to de-energize exposed contacts whenever an end of the cable is disconnected constitutes compliance with the requirement in 14.4.

## 15 Receptacles and Connectors

15.1 A general-purpose receptacle shall involve line power only.

15.2 If the face of a general-purpose receptacle is less than 5/8 inch (15.9 mm) wide or less than 7/8 inch (22.2 mm) long, the face of the receptacle shall project not more than 3/16 inch (4.8 mm) from the part of the mounting surface that is within a rectangle, 5/8 inch wide and 7/8 inch long, symmetrically located about the receptacle contacts; and if the mounting surface is conductive, the face of the receptacle shall project at least 3/32 inch (2.4 mm) from that part of the mounting surface.

15.3 The area surrounding an unused general purpose receptacle shall be free of any projection that would prevent full insertion of the blades of a circular attachment plug having a face diameter of 1-5/16 inches (33.3 mm) and for a rectangular attachment plug having face dimensions 1-1/2 by 1 inches (38.1 by 25.4 mm) unless the projection is such that the blades of the attachment plug are prevented from being inserted to make electrical contact with the female contacts of the receptacle.

15.4 A receptacle or connector that:

- a) Is of other than the general-purpose type;
- b) Is with or without a jumpered plug;
- c) Involves energy in excess of that defined in 32.1 – 32.9; and
- d) Is accessible to a user,

shall be a female-type that requires the mating connector to have all contacts exposed, and have guards for pin terminals (see 7.2.1 – 7.2.4).

15.5 A convenience receptacle that is provided on an appliance intended to be grounded shall be of a grounding type. The grounding contact of the receptacle shall be electrically connected to the frame of the appliance.

15.6 An unused receptacle, such as one provided for the attachment of an accessory, that involves a risk of fire or electric shock shall not be of the type generally employed as a receptacle for a single-prong, shielded-type phonograph plug.

15.7 A receptacle or connector, other than as specified in 15.1 and 15.4, shall not involve energy in excess of that defined in 32.1 – 32.9 under intended operating conditions, or other conditions that may include:

- a) The introduction of any of one short circuit or any one open circuit in any one component, such as a vacuum tube, a rectifier, an electrolytic capacitor, a solid-state component, or another component with unreliable spacings or unreliable insulating materials; and
- b) The connection of any connector terminal to the chassis, to ground, or to any other accessible part.

15.8 A connector body, used in a circuit that is not a low-voltage, limited-energy circuit, shall be constructed from material rated V-0, V-1, or V-2.

15.8 revised April 9, 1999

15.9 A nominal 0.110-, 0.125-, 0.187-, 0.205-, or 0.250-inch wide, quick-connect terminal shall comply with the Standard for Electrical Quick-Connect Terminals, UL 310. Other sizes of quick-connect terminals shall be investigated with regard to crimp pull-out, engagement-disengagement forces of the connector and tab, and temperature rises; all tests are to be conducted in accordance with UL 310.

## 16 Separation of Circuits

16.1 Insulated conductors shall be segregated from uninsulated energized parts of a different circuit.

*Exception: Low-voltage, limited-energy circuits are not required to be segregated from each other.*

16.2 Segregation may be accomplished by clamping, routing, barriers, or an equivalent means that provides permanent separation from uninsulated energized parts of a different circuit.

16.3 A barrier used to segregate wiring from uninsulated energized parts shall be of metal or of insulating material, of acceptable mechanical strength, and securely held in place.

16.4 The thickness of a metal barrier shall be the same as the thickness required for a metal enclosure.

16.5 With reference to 16.3, a barrier of insulating material shall be at least 0.028 inch (0.71 mm) thick and shall be thicker if it may be readily deformed so as to defeat its purpose.

## 17 Insulating Material

### 17.1 Electrical insulation

17.1.1 An insulating washer, a bushing, or a similar part, that is an integral part of an appliance, and a base or support for the mounting of electrical parts shall be of a moisture-resistant material that will not be damaged by the temperatures to which it will be subjected to during intended use of the appliance.

17.1.2 A molded part shall be constructed so that it will have the mechanical strength and rigidity necessary to withstand stresses that may occur during intended use of the appliance.

17.1.3 Insulating material employed in an appliance is evaluated with regard to its acceptability for the particular application. Materials, such as mica, some molded compounds, and certain refractory materials are usually acceptable for use as the sole support of electrical parts. A material that is not

acceptable for general use, such as magnesium oxide, may be accepted if used in conjunction with other insulating materials that are acceptable or if located and protected so that mechanical damage and the absorption of moisture are prevented.

17.1.4 When an investigation is required to determine whether a material is acceptable, consideration shall be given to:

- a) Mechanical strength;
- b) Dielectric characteristics;
- c) Electrical resistance;
- d) Resistance to heat;
- e) The degree to which it is enclosed or protected; and
- f) Any other features that may involve a risk of fire, electric shock, or injury to persons during the intended operation of the appliance.

All of these factors shall be considered with regard to thermal aging. See 17.1.5.

17.1.5 A polymeric material may be employed for the sole support of uninsulated electrical parts only if determined to be acceptable in accordance with the Standard for Polymeric Materials – Use in Electrical Equipment Evaluations, UL 746C.

## 17.2 Thermal insulation

17.2.1 Flammable or electrically conductive thermal insulation material – including some types of mineral-wool thermal insulation containing conductive impurities in the form of slag – shall not be located so as to contact uninsulated electrical parts.

## 18 Overcurrent Protection

### 18.1 General

18.1.1 Other than for the operating handle, a circuit breaker shall be inaccessible from outside the appliance.

18.1.2 Where circuit breaker handles are operated vertically rather than horizontally, the “up” position of the handle shall be the “on” position.

Added 18.1.2 effective April 9, 2000

18.1.3 Other than as noted in 18.1.4, a fuse involving energy in excess of that defined in 32.1 – 32.9 shall be inaccessible:

- a) From outside the appliance and
- b) During user servicing.

18.1.4 A fuse that is intended to be serviced by the user shall be secured in a holder constructed and installed so that no live parts will be exposed to contact during fuse replacement.

18.1.5 If a polarized attachment plug is used, the screw shell of a plug fuseholder and the outer contact of an extractor fuseholder shall be connected toward the grounded side of the supply.

18.1.6 A device providing overload protection shall be of a type that is acceptable for use when supplied directly by the branch circuit to which the equipment can properly be connected or additional acceptable protection is provided ahead of the device in the equipment.

18.1.7 A thermal or overload protective device shall not open the circuit during the intended use of the appliance.

18.1.8 The functioning of an overload protective device provided as part of an appliance shall not result in a risk of fire, electric shock, or injury to persons during operation of the appliance.

18.1.9 A circuit breaker connected in the input circuit shall open all ungrounded conductors.

*Exception: If an appliance has provision for connection of a grounded neutral conductor, individual single-pole circuit breakers are acceptable as the protection for each ungrounded conductor of a 3-wire, single-phase circuit or for each ungrounded conductor of a 4-wire, 3-phase circuit provided that no conductor involves a potential to ground in excess of 150 V.*

## 18.2 Motors

18.2.1 The following shall be provided with overload protection as specified in 18.2.4:

- a) A continuous-duty motor in a permanently-connected appliance;
- b) An automatically-controlled, fractional-horsepower motor in an appliance;
- c) The motor of an appliance intended to be operated remotely or unattended – see 18.2.2;
- d) A motor of which the operation or inoperation is not evident to the operator;
- e) A continuous-duty, integral-horsepower motor; and
- f) A motor that can be overloaded, stalled, or otherwise rendered inoperable, by manipulation of the controls.

For a multi-speed motor, the protection shall be effective at all speed settings.

18.2.2 Provision of a switch for automatically disconnecting an appliance from the branch-circuit supply upon completion of a specific amount of work, of and by itself, does not constitute unattended operation.

18.2.3 If the overload protection of a branch circuit to which an appliance that includes a motor can properly be connected does not provide acceptable protection for the motor in accordance with the National Electrical Code, ANSI/NFPA 70, such protection shall be included in the appliance.

18.2.4 The overload protection required by 18.2.1 and 18.2.3 shall consist of one of the following:

- a) Thermal protection complying with both the locked rotor and running overload requirements in the Standard for Overheating Protection for Motors, UL 2111.

*Exception: A shaded pole motor having a difference of 1 A or less between no-load and locked-rotor currents and having a 2:1 or smaller ratio between locked-rotor and no-load currents, and a direct-drive fan motor is required to be protected against locked-rotor conditions only.*

- b) Impedance protection complying with the requirements in UL 2111, when tested as used in the application.
- c) Other protection that tests show is equivalent to the protection described in (a).

### 18.3 Lampholders and receptacles

18.3.1 If an appliance includes one or more circuits supplying power to one or more medium-base or smaller lampholders or to one or more attachment-plug receptacles, and the overcurrent protection of the branch circuit to which the appliance can properly be connected in accordance with the National Electrical Code, ANSI/NFPA 70, is inadequate for the protection of the lampholder or receptacle circuits, each circuit shall have individual overcurrent protection rated not more than 20 A provided as a part of the appliance.

### 18.4 Primary circuits

18.4.1 All wiring, including supply cords and inter-connecting cables, used in the distribution of primary electrical energy within and between parts of an appliance and all transformers and other loading devices connected to the primary circuit shall be protected against burnout and damage to insulation resulting from any overload or short-circuit condition that can occur during operation of the equipment.

*Exception: Wiring in a limited primary circuit as described in 30.4.1 and 30.4.2 is not required to comply.*

18.4.2 The protection described in 18.4.1 may be obtained from acceptably rated overload devices included as integral parts of the equipment or, if of the proper rating, from the protection associated with the branch circuit to which the equipment is connected.

18.4.3 Flexible cord as specified in Table 18.1 is acceptably protected in accordance with 18.4.1.

**Table 18.1**  
**Protection of flexible cord**

Size of branch circuit, amperes	Minimum size of cord acceptably protected in accordance with 18.4.1
20	No. 18 AWG (0.82 mm <sup>2</sup> )
30	10 ampere capacity
40	20 ampere capacity
50	20 ampere capacity

### 18.5 Secondary circuits

18.5.1 All external secondary-circuit interconnecting cables and all secondary-circuit wiring between portions of an appliance shall be protected against burnout and damage to the insulation resulting from any overload or short-circuit condition that can occur during the intended operation of the appliance.

18.5.2 A conductor provided with overcurrent protection complying with the National Electrical Code, ANSI/NFPA 70, is acceptably protected in accordance with 18.5.1.

18.5.3 With reference to 18.5.1, a secondary circuit that is derived from a power supply or other source that is either inherently limited, or includes a sensing device the operation of which achieves the same result, prevention of burnout, and damage to insulation resulting from overload, or de-energizes the appliance, is acceptable if the output wiring can carry the maximum current available from the power supply without discoloration or softening of insulation.

18.5.4 The overcurrent protection provided in the primary circuit of the transformer may be considered to be acceptable protection for the secondary circuits if it operates to protect the circuit under all overcurrent conditions, including short-circuit.

## 19 Short-Circuit and Ground-Fault Protection

19.1 The overcurrent protection devices specified in 19.5 – 19.7 shall be located in each ungrounded conductor, and shall comply with the requirements for branch-circuit protection.

19.1 added April 9, 1999

19.2 A fuse used for overcurrent protection referred to in 19.1 shall be a Class CC, G, H, J, K, L, RK, or T cartridge fuse, a Type S fuse, an Edison-base plug fuse, or the equivalent.

19.2 added April 9, 1999

19.3 The screw shell of a plug fuseholder and the accessible contact of an extractor fuseholder shall be connected toward the load.

19.3 added April 9, 1999

19.4 The rating of the branch-circuit overcurrent-protective device shall be 150 percent of the rating of the appliance unless the appliance is marked to specify the use of a protective device having a higher rating. Standard ampere ratings for overcurrent-protective devices are 15, 20, 25, 30, 35, 40, 45, 50, 60, 70, 80, 90, 100, 110, 125, 150, 175, and 200. When 150 percent of the rating of the appliance does not equal one of the standard overcurrent-protective device ratings mentioned above, the next higher rating or setting of overcurrent-protective device shall be used.

19.4 added April 9, 1999

19.5 A motor or transformer in an appliance rated more than 16 amperes shall be protected by an overcurrent-protective device incorporated into the appliance. The overcurrent-protective device shall have a maximum ampere rating in accordance with the National Electrical Code, ANSI/NFPA 70.

*Exception No. 1: An overcurrent-protective device is not required as a part of the appliance when it is determined that equivalent or better protection is obtained from the branch-circuit overcurrent-protective device through which the appliance is supplied.*

*Exception No. 2: A motor having an inherent thermal protector that complies with the requirements for such devices as described in the Standard for Overheating Protection for Motors, UL 2111, does not require an additional overcurrent-protective device if, in the appliance, it is connected in series with a branch-circuit overcurrent-protective device of the same type and having a current rating equal to or less than that with which the motor-protector combination was tested during the investigation of the protector.*

*Exception No. 3: An overcurrent-protective device is not required for an appliance where the rating of the wiring terminals or leads is not less than the rating of the appliance if, when the appliance is operated continuously for at least 3 hours as described for the normal temperature test, the average current input to the appliance is 16 amperes or less and it is:*

- a) *Intended for connection to a nominal, 120-volt branch circuit;*



b) *Intended to have one or more motors and each motor complies with the requirements in UL 2111;*

c) *Rated from 16 – 20 amperes when tested under intended conditions.*

19.5 added April 9, 1999

19.6 Each lampholder circuit in a permanently-connected appliance having a lampholder independent of any heating-element circuit shall have overcurrent protection rated not more than 20 amperes in the appliance, if the overcurrent protection of a branch circuit to which the appliance may be connected will not be adequate for the lampholder.

19.6 added April 9, 1999

19.7 An attachment-plug receptacle intended for general use shall have overcurrent protection rated not more than 20 amperes in the appliance unless the appliance is intended for connection to a branch circuit rated 20 amperes or less.

19.7 added April 9, 1999

## **20 Motors**

20.1 A motor shall drive its maximum normal load during operation of the appliance (see 51.2.1.1) without introducing a risk of fire, electric shock, or injury to persons.

20.2 A motor winding shall resist the absorption of moisture. For cord-connected appliances see Leakage Current Following Humidity Conditioning, Section 48.

20.3 With reference to the requirements in 20.2, film coated wire is not required to be additionally treated to prevent absorption of moisture, but fiber slot liners, cloth coil wraps and similar moisture-absorptive materials shall be provided with impregnation or otherwise treated to prevent absorption of moisture.

20.4 A brushholder assembly shall be constructed so that when a brush is worn out and no longer capable of performing its function, the brush, spring, and other parts of the assembly will be retained to the degree necessary to reduce the risk of an accessible dead-metal part from becoming energized, and live parts from becoming accessible.

## **21 Switching Devices**

### **21.1 General**

21.1.1 A switch or other control device, such as a relay, shall have a current rating and a voltage rating acceptable for the application.

*Exception: A switch in an isolated secondary or battery circuit controlling loads of 100 volt-A or less is not required to comply.*

### **21.2 Rating**

21.2.1 The current rating of a switch or other control device that controls a solenoid, a magnet, a transformer, an electric-discharge-lamp ballast, or other inductive load is to be at least twice the full-load current of the component that is controlled unless the switch is specifically rated for the particular application.

21.2.2 A switch or other control device that controls a lampholder for an incandescent lamp other than a 15 watt or smaller pilot or indicating lamp shall:

- a) Be rated for use with tungsten-filament lamps or
- b) Have a current rating greater than or equal to six times the steady-state tungsten load for alternating current or ten times the steady state-load for direct current.

21.2.3 A motor control device shall be used in a cord-connected appliance to control a motor rated more than 1/3 horsepower (250 watts output).

21.2.4 A switch or other control device for a combination load including one or more motors, lamps, heaters, and similar devices shall:

- a) Have a horsepower rating not less than the combined load of the motor or motors and an ampere rating not less than the sum of the following:
  - 1) The locked rotor current of the motor or motors,
  - 2) Twice the full-load current of inductive loads as specified in 21.2.1, and
  - 3) Six or ten times the steady-state tungsten-filament lamp load in accordance with item of 21.2.2; or
- b) Be investigated for compliance with the requirements for that component using the maximum intended load.

21.2.5 In the application of 21.2.4 to a motor not rated in horsepower, the appropriate table of the National Electrical Code, ANSI/NFPA 70, is to be used to determine the relationships between horsepower, full-load currents, and locked rotor currents for motors.

21.2.6 A switch provided as part of a product intended to be connected to a power-supply circuit having a potential to ground of more than 150 V shall be acceptable for the maximum potential to ground of the circuit.

21.2.7 A nominal 208 volt, single- or 3-phase, or a 120/240 volt, single-phase product is considered to involve a potential to ground of less than 150 V. A 2-wire, single-phase or a 3-wire, 3-phase product with a rating in the range from 220 – 240 V is considered to involve a potential to ground in excess of 150 V.

## 22 Lampholders

22.1 A lampholder shall be constructed or installed so that a person removing or replacing a lamp in normal service is not exposed to live parts other than a screw shell or bayonet.

*Exception No. 1: Live parts may be exposed only if it is necessary to dismantle the appliance, or remove a cover plate or other part by means of a tool, in order to remove or replace the lamp.*

*Exception No. 2: A lampholder for a projection lamp is to be constructed so that persons servicing the lamp cannot touch live parts of the lampholder with the lamp in place.*

## 23 Medium- and High-Pressure Lamps

23.1 A medium-pressure lamp is considered to be one in which the Contained Atmospheric Energy (CAE) is greater than 0.5 joules and less than 5 joules. A high-pressure lamp is considered to be one in which the CAE equals or exceeds 5 joules cold (50°C or less) when defined as follows:

$$CAE = 0.15 (PC - PE) V$$

*in which:*

*PC is the contained pressure in atmospheres;*

*PE is the external pressure in atmospheres; and*

*V is the volume in cubic centimeters.*

23.2 A medium-pressure lamp shall be enclosed or guarded to protect against breakage due to external forces or impacts.

23.3 A high-pressure lamp shall be enclosed so that an explosion of the lamp is contained. See 67.3.1 for high-pressure lamp caution notice.

23.4 A high-pressure lamp system shall comply with the requirements contained in Supplement SA of this standard.

Added 23.4 effective April 9, 2000

23.5 A high-pressure lamp whose ambient temperature at the conductors as installed can exceed 50°C (122°F) shall employ insulated conductors having a rated operating temperature of not less than 200°C (392°F).

Added 23.5 effective April 9, 2000

## 24 Capacitors

### 24.1 Motor and power-factor capacitors

24.1.1 A capacitor provided as a part of a capacitor motor and a capacitor connected across-the-line for power-factor correction shall be housed within an enclosure or container that:

- a) Protects the plates against mechanical damage and
- b) Prevents the emission of the flame or molten material resulting from deterioration or breakdown of the capacitor.

24.1.2 A capacitor employing a liquid dielectric medium more combustible than askarel shall prohibit the expulsion of the dielectric medium when tested in accordance with the applicable performance requirements in this standard including faulted-overcurrent conditions based on the branch circuit in which it is used.

24.1.3 The container of a capacitor as specified in 24.1.1 shall be of metal having a thickness not less than 0.026 inch (0.66 mm).

*Exception: Sheet steel less than 0.026 inch thick, or material other than metal is not prohibited from being used when the capacitor is mounted in an overall enclosure that houses other parts of the appliance, and when such a box or case or similar device is acceptable for the enclosure of live parts.*

24.1.4 Thermal or overcurrent protection shall be provided in an automatic appliance if a capacitor that is not a part of a permanent-split-capacitor motor or part of a capacitor-start motor is connected so that capacitor deterioration or breakdown would otherwise result in a risk of fire, electric shock, or injury to persons.

## 24.2 Isolating capacitors

24.2.1 A capacitor used for line-bypass, for metal cabinet isolation, or between live parts and exposed metal parts where the capacitor is continually stressed, shall comply with the requirements in the Standard for Across-the-Line, Antenna-Coupling, and Line-by-Pass Capacitors, for Radio- and Television-Type Appliances, UL 1414.

## 24.3 Interference elimination capacitors

24.3.1 A capacitor connected across the supply circuit for interference elimination shall comply with the Standard for Across-the-Line, Antenna-Coupling, and Line-by-Pass Capacitors for Radio- and Television-Type Appliances, UL 1414.

*Exception: An electromagnetic interference (EMI) filter is not required to comply.*

24.3.2 An interference elimination capacitor is considered to be connected across the supply circuit when used in either of the following applications:

- a) If, with the capacitor in a shorted condition, a current of more than 1 A passes through the capacitor when the appliance is in a heated condition. The current through the capacitor can be limited to 1 A or less by:
  - 1) A fixed impedance or
  - 2) A protective device rated 1 A or less; or
- b) A capacitor used for line-bypass in an appliance provided with a terminal or connector intended to be grounded.

## 24.4 Capacitor discharge

24.4.1 A means, such as a bleeder resistor, shall be provided to drain the charge stored in a capacitor so that the potential (V), measured between the terminals of the capacitor 1 minute after the appliance has been disconnected from its source of energy, is less than 50 V, and energy stored (J) is less than 20 joules as determined from the formula:

$$J = 5 \times 10^{-7} CV^2$$

*in which:*

*C is the capacitance in microfarads (see 53.1).*

*Exception No. 1: Household photoflash equipment does not require a bleeder resistor.*

*Exception No. 2: The discharge time of 1 minute may be extended up to 5 minutes if the appliance is marked as specified in 67.4.1.*

## 24.5 Capacitor rating

24.5.1 The voltage rating of a capacitor other than a motor-starting or constant-voltage transformer capacitor shall be at least the maximum steady-state potential to which the capacitor is subjected during operation of the appliance at rated voltage. See 53.1.

## 25 Transformers

25.1 A transformer shall comply with the requirements in one of the following:

- a) The Standard for Specialty Transformers, UL 506;
- b) The Standard for Class 2 Power Units, UL 1310;
- c) The Standard for Class 2 and Class 3 Transformers, UL 1585; or
- d) The Standard for Transformers and Motor Transformers for Use in Audio-, Radio-, and Television-Type Appliances, UL 1411.

## 26 Heating Elements

26.1 A heating element shall be protected against mechanical damage.

26.2 A heating element shall be supported such that sagging, loosening, and other adverse conditions resulting from continuous heating do not result in a risk of fire or electric shock.

26.3 An open-wire element, such as uninsulated resistance wire, may be used in heating appliances provided it is enclosed or protected by barriers or covers which require tools for removal, and it complies with the requirements for accessibility of electrical parts specified in Accessibility of Live Parts, Section 7.

26.4 A heating appliance in which the heating element is intended to operate only in an air blast shall be wired or controlled so that the element can be operated only while under the cooling effect of the blast. An appliance in which the cooling effect of the motion of a part is necessary to prevent excessive temperatures shall be wired or controlled so that the element cannot be operated without such motion.

26.5 A sheathed heating element used in air or immersed in liquid shall comply with the Standard for Sheathed Heating Elements, UL 1030, or the Standard for Electric Heating Appliances, UL 499.

## 27 Printed-Wiring Boards

27.1 A printed-wiring board used in a primary circuit, a secondary circuit, or any other circuit where breakdown of the bond between the conductor and the base material may result in a risk of fire or electric shock, shall comply with the Standard for Printed-Wiring Boards, UL 796.

27.2 A printed-wiring board located in other than a low-voltage, limited-energy circuit shall have a flammability classification, in accordance with the Standard for Tests for Flammability of Plastic Materials for Parts in Devices and Appliances, UL 94, of V-0, V-1, or V-2.

27.2 revised April 9, 1999

## 28 Lasers

28.1 A laser component provided in photographic equipment shall comply with the Code of Federal Regulations, 21 CFR 1040.

Added 28.1 effective April 9, 2000

28.2 With reference to 28.1, compliance of laser products with the Code of Federal Regulations (CFR), Title 21, Part 1040, shall be determined by:

- a) Determining the Class of laser (as defined by the CFR) from the manufacturers required documentation, such as the Center for Devices and Radiological Health (CDRH) report, markings and labels, or similar documentation;
- b) Verifying that the manufacturer's markings and labels, having the information specified in the CFR, are affixed on the laser product (as defined in the CFR);
- c) Determining that the corresponding construction features, such as protective housing, interlocks, and similar features, are provided in accordance with the CFR; and
- d) Determining that the resulting construction complies with the construction requirements of this standard.

28.2 added July 11, 2001

## **29 Modems and Modem Cards**

29.1 A modem or modem card shall comply with the Federal Communication Commission (FCC) Rules, Part 68, and the requirements in either the Standard for Telephone Equipment, UL 1459, or the Standard for Information Technology Equipment, UL 1950.

Added 29.1 effective April 9, 2000

## **30 Spacings**

### **30.1 General**

30.1.1 All uninsulated electrical parts connected to different line-voltage or secondary circuits shall be spaced from one another as though they were parts of opposite polarity in accordance with the requirements in 30.2.2 and shall be evaluated on the basis of the highest voltage involved. See 53.1.

### **30.2 Field-wiring terminal spacings**

30.2.1 The spacings between field-wiring terminals of opposite polarity and the spacings between a field-wiring terminal and any other uninsulated metal part, dead or live, not of the same polarity shall not be less than the applicable values specified in Table 30.1.

**Table 30.1**  
**Spacings at field-wiring terminals**

Potential involved, volts <sup>a</sup>	Minimum spacings				
	Between field-wiring terminals, through air or over surface, inch <sup>b</sup> (mm)		Between terminals and other uninsulated parts not always of the same polarity		
			Over surface, inch <sup>b</sup> (mm)		Through air, inch <sup>b</sup> (mm)
0 – 50	1/8	3.2	1/8	3.2	1/8 3.2
51 – 250	1/4	6.4	1/4	6.4	1/4 6.4
251 – 600	1/2 <sup>c</sup>	12.7	1/2 <sup>c</sup>	12.7	3/8 9.5
Over 600	see Table 30.2		see Table 30.2		

<sup>a</sup> See 53.1.  
<sup>b</sup> Applies to the sum of the spacings involved where an insulated dead-metal part is interposed. See 30.5.1.  
<sup>c</sup> A spacing of not less than 3/8 inch (9.5 mm) through air and over surface is acceptable at wiring terminals in a wiring compartment or terminal box if the compartment or box is integral with a motor.

30.2.2 At terminal screws and studs to which connection can be made in the field by means of a wire connector, an eyelet, or similar part, as described in 4.4, the spacings shall not be less than the values specified in Table 30.2 while such connectors, eyelets, and similar parts, are in such position that minimum spacings – opposite polarity and to dead metal – exist.

No Text on This Page



### 30.3 Primary circuit spacings

30.3.1 Other than at field-wiring terminals and in a motor, the spacing between uninsulated electrical parts of opposite polarity and between an uninsulated electrical part and a dead-metal part that is exposed to contact by persons or that may be grounded shall not be less than the value specified in Table 30.2. If an uninsulated electrical part is not rigidly fixed in position by means other than friction between surfaces or if a movable dead-metal part is in proximity to an uninsulated electrical part, the construction shall be such that the spacing will be maintained.

*Exception: As provided in 30.3.2, 30.4.1, and 30.6.1.*

**Table 30.2**  
**Primary circuit spacings other than at field-wiring terminals**

Potential involved, volts <sup>a</sup>	Minimum spacing,			
	Over surface,		Through air,	
	inch	(mm)	inch	(mm)
0 – 50	3/64	1.2	3/64	1.2
51 – 125	1/16 <sup>b</sup>	1.6	1/16 <sup>b</sup>	1.6
126 – 250	3/32 <sup>b</sup>	2.4	3/32 <sup>b</sup>	2.4
251 – 600	1/2 <sup>c,d</sup>	12.7	3/8 <sup>c,d</sup>	9.5
601 – 3000	3/4 <sup>d,e,f</sup>	19.0	3/4 <sup>d,e,f</sup>	19.0
3001 – 5000	1	25.4	1	25.4
5001 – 10000	1-1/8 <sup>f</sup>	28.6	1-1/8 <sup>f</sup>	28.6
	1-1/2 <sup>e</sup>	38.1	1-1/2 <sup>e</sup>	38.1
10001 – 15000	1-1/2 <sup>e,f</sup>	38.1	1-1/2 <sup>e,f</sup>	38.1

NOTE – This table does not apply to an appliance employing a motor having a diameter greater than 7 inches (178 mm). The diameter is to be measured in the plane of the laminations of the circle circumscribing the stator frame, excluding boxes, fins, lugs, and the like, used solely for motor mounting, assembly, cooling, or connection. This table does not apply to spacings within motors; see 30.3.3.

<sup>a</sup> See 53.1.

<sup>b</sup> At a closed-in point, such as a screw and washer construction of an insulated stud mounted in metal, a spacing of 3/64 inch (1.2 mm) is acceptable.

<sup>c</sup> Film-coated wire is considered to be an uninsulated live part. However, 3/32-inch (2.4-mm) and greater spacings over surface and through air are acceptable between a dead-metal part and film-coated wire that is rigidly supported and held in place on a coil.

<sup>d</sup> Printed-wiring boards and their connectors wired on the load side of line filters – or similar voltage-peak-reduction networks and components – 3/32 inch plus 0.0002 inch (0.005 mm) per volt peak above 353.5 volts peak [0.094 plus 0.0002 (Vpk minus 353.5)] inch spacings over surface and through air are acceptable between uninsulated live parts of opposite polarity and between uninsulated live parts and any other uninsulated conductive parts, live or dead, not of the same polarity.

<sup>e</sup> Between an uninsulated high-voltage part and an insulated high-voltage part of opposite polarity or of different potential, a grounded metal part, and an uninsulated primary-circuit part.

<sup>f</sup> Between an uninsulated high-voltage part and an insulated primary-circuit part, and an insulated high-voltage part of opposite polarity or of different potential.

30.3.2 The spacing requirements given in 30.3.1 do not apply to the inherent spacings of a component of the appliance, such as a snap switch; such spacings shall be evaluated on the basis of the requirements for the component.

30.3.3 The spacings for a motor shall comply with the spacing requirements in the Standard for Electric Motors, UL 1004.

#### **30.4 Limited-primary circuit spacings**

30.4.1 Spacings between uninsulated live parts of opposite polarity in a limited primary circuit may be less than the applicable values specified in Table 30.2, when the parts involved withstand the dielectric voltage-withstand test described in 55.2.1 and 55.2.2.

30.4.2 To determine when a primary circuit is a limited primary circuit, a variable resistor is to be connected between the point in the circuit to be tested and the circuit return. The external resistor is first to be adjusted for 50 watts, when available, and held for 1 minute. During the 1-minute period the resistor is to be readjusted, when required, to maintain 50 watts as indicated by the reading on the wattmeter that is connected to measure the power dissipated by the resistor. When at the end of 1 minute the wattmeter reading is 50 watts, the point being measured is considered to have an available power of 50 watts or more. When by the end of the 1-minute period the power cannot be maintained at the 50 watt level, or when a component opens the circuit before the 1-minute period is completed, the point being measured is considered to have an available power of less than 50 watts, and is part of a limited primary circuit.

#### **30.5 Multiple spacings**

30.5.1 If an isolated dead-metal part is interposed between or is in close proximity to:

- a) Live parts of opposite polarity,
- b) A live part and an exposed dead-metal part, or
- c) A live part and a dead-metal part that may be grounded,

the spacing shall not be less than 3/64 inch (1.2 mm) between the isolated dead-metal part and any one of the other parts specified, provided the total spacing between the isolated dead-metal part and the two other parts is not less than the value specified in Tables 30.1 and 30.2.

#### **30.6 Barriers for spacings**

30.6.1 An insulating liner or barrier of vulcanized fiber or similar material is not prohibited from being used where a spacing would otherwise be less than the acceptable value when it is located or of such material so that it is not affected adversely by arcing, and is:

- a) Not less than 1/32 inch (0.8 mm) thick;
- b) Not less than 1/64 inch (0.4 mm) thick and used in conjunction with an air spacing of not less than 50 percent of the acceptable through-air spacings; or
- c) A barrier, of other than vulcanized fiber, having a thickness less than that specified in (a) or (b) when, upon investigation, it is determined to be acceptable for the particular application.

See Insulating Material, Section 17.

### 30.7 Secondary and battery circuit spacings

30.7.1 The requirements for primary circuit spacings apply to:

- a) All secondary and battery circuits that are safety circuits.
- b) All secondary circuits supplied by a transformer winding with an available power of 200 watts or more and a potential more than 100 V.

30.7.2 The spacings in secondary and battery circuits other than as specified in 30.7.1, shall be evaluated on the basis of the dielectric voltage-withstand tests in 55.3.2.

*Exception: The spacing between uninsulated live parts of opposite polarity and between such a part and a dead-metal part that may be grounded in normal use is not specified for low-voltage, limited-energy circuits (see 31.4); and commercial equipment; low-voltage, printed-wiring assemblies; and subsequent circuits (see 31.3).*

30.7.3 With reference to 30.7.1(b), the capacity of a transformer winding is to be determined by replacing the intended load on that winding with a variable resistor that has been set to maximum resistance and a wattmeter connected to measure the power dissipated by the resistor. The assembly is to be energized, the variable resistor is to be continuously adjusted to dissipate maximum power, and the power value is to be measured after 1 minute of operation. This value is considered to be the winding capacity.

### 31 Secondary and Battery Circuits

31.1 A secondary or battery circuit may be connected to the frame of an appliance.

31.2 If any secondary or battery circuit of more than 42.4 V peak is connected to the frame of an appliance, all exposed dead-metal parts that might become energized, and all dead-metal parts within the enclosure that may be touched by a person during operator servicing and that might become energized, shall be connected together.

31.3 Commercial equipment printed-wiring assemblies and subsequent circuitry used in secondary circuits that do not involve a risk of electric shock are not to be investigated. However, power supplies and power-distribution components, such as bus bars, wiring connectors, and similar parts up to and including printed-wiring receptacles and connectors shall be investigated. Printed-wiring boards and insulated wire used in such circuits shall be acceptable for the application. See Internal Wiring, Section 12, and Printed-Wiring Boards, Section 27.

31.4 Unless otherwise noted, there is no specification for insulating material, spacings, and components in a low-voltage, limited-energy circuit, except as may be required to prevent contact with an uninsulated live part of other circuits (for example, wiring is to be reliably routed).

### 32 Low-Voltage, Limited-Energy Circuits

32.1 A circuit supplied from a Class 2 transformer that complies with the Standard for Class 2 and Class 3 Transformers, UL 1585, rated 30 V rms sinusoidal or less, is considered to be a low-voltage, limited-energy circuit.

32.2 A circuit supplied by a single source consisting of a battery, an isolating transformer, or a power supply that includes an isolating transformer, is considered to be a low-voltage, limited-energy circuit, if the open-circuit potential or no-load output of the supply is not more than 42.4 V peak, and the energy available to the circuit is limited so that the current under any condition of load including short circuit is not more than 8 A after 1 minute of operation. See 56.5.1.

32.2 revised April 9, 1999

32.3 With reference to the voltage limit specified in 32.2, measurement is to be made on a fully charged battery; or with the appliance, the power supply, or the transformer primary connected to the voltage specified in 45.1 and with all loading circuits disconnected from the battery, transformer, or power supply under test. Measurements may be made at the output terminals of the battery, transformer, or power supply. If a tapped transformer winding is used to supply a full-wave rectifier, voltage measurement is to be made from either end of the winding to the tap.

32.4 If the power supply described in 32.2 is not limited as to available short-circuit current, by construction of the battery or transformer but the circuit includes either a fixed impedance, a fuse, a nonadjustable manually reset circuit-protective device, or a regulating network, the circuits in which the current is limited in accordance with 32.5 or 32.6 are considered to be low-voltage, limited-energy circuits, and are not required to be investigated.

32.5 A fuse or circuit-protective device used to limit the current in accordance with 32.4 shall be rated or set at not more than the values specified in Table 32.1.

**Table 32.1**  
**Rating for fuse or circuit protector**

Open-circuit volts (peak)	Amperes
0 – 21.2	5.0
21.3 – 42.4	3.2

32.6 A fixed impedance or a regulating network used to limit the current in accordance with 32.4 shall be of such value that the current under any condition of load including short circuit does not exceed 8 A measured after 1 minute of operation. See 56.5.1.

32.7 If a regulating network is used to limit the voltage or current in accordance with 32.2 – 32.6 and the performance may be adversely affected by breakdown – either by short- or open-circuit – of any single component in the network the risk of such breakdown occurring shall be determined by investigation of that component.

32.8 In a circuit of the type described in 32.6, the battery or secondary winding of the transformer, the fuse or circuit-protective device, or the regulating network, and all wiring up to the point at which the current and voltage are limited shall be evaluated under the applicable requirements in this standard.

32.9 A wire or cable that is part of the battery or secondary circuits covered by 32.3 – 32.8 shall be provided with strain relief and push-back relief in accordance with 10.1.2.1 and 10.1.3.1 if stresses on the wire or cable could cause the internal wiring of the circuits to contact uninsulated live parts of other circuits.

### 33 Safety Circuits

33.1 A safety circuit shall comply with the requirements for line-voltage circuits.

### 34 Liquid Containers, Seals, and Diaphragms

34.1 A liquid container, a seal, or similar part, the deterioration of which is capable of resulting in a risk of fire, electric shock, or injury to persons, shall be resistant to deterioration from the liquid intended to be used in contact with that component, as determined by investigation.

34.2 The test procedure for determining whether a component complies with the requirement in 34.1 depends upon the material of which it is composed, its size and shape, the mode of application in the appliance, and other factors. The test procedure might include visual inspection for determination of cracks, deformation, and similar deterioration, after accelerated aging, as well as comparison of hardness, tensile strength, and elongation before and after accelerated aging. See Table 34.1 for accelerated aging test requirements.

34.2 revised April 9, 1999

34.3 With reference to 34.1 and 34.2, a component of rubber or neoprene, if tested to compare its tensile strength and elongation before and after accelerated aging, is not acceptable if these properties are determined to be less than the values specified in Table 34.1 corresponding to the temperature of the component during the temperature test.

34.3 revised April 9, 1999

**Table 34.1**  
**Accelerated aging tests**

Table 34.1 revised April 9, 1999

Temperature on component during normal-temperature test	Accelerated-aging procedure	Minimum percent of original	
		Tensile strength	Elongation
60°C (140°F) or less	Immersion for 168 hours at 70 ±1°C (158.0 ±1.8°F) in the liquid to which the component is exposed	50	50
	Air-oven for 70 hours at 100 ±2°C (212.0 ±3.6°F) and 300 ±10 pounds per square inch (2070 ±70 kPa) gauge	60	60
More than 60°C (140°F)	Immersion for 168 hours in a boiling solution of commercial dishwashing detergent (25 grams per liter of water) <sup>a</sup>	50	50
61 – 75°C (142 – 167°F)	Air-oven for 168 hours at 100 ±2°C (212.0 ±3.6°F) and 300 ±10 pounds per square inch (2070 ±70 kPa) gauge	50	50
76 – 90°C (169 – 194°F)	Air oven for 168 hours at 121 ±1°C (249.8 ±1.8°F)	60	60
91 – 105°C (196 – 221°F)	Air oven for 168 hours at 136 ±1°C (276.8 ±1.8°F)	60	60

<sup>a</sup> If the part is not subjected to a detergent solution, the appropriate agent should be substituted for this test.

## PROTECTION AGAINST INJURY TO PERSONS

### 35 General

35.1 If the operation and maintenance of an appliance involves a risk of injury to persons, or there can be a risk of injury resulting from the presence of toxic or flammable chemicals, and the like, means shall be provided to reduce the risk. Persons shall be protected during user servicing.

35.2 If an appliance involves the generation and confining under pressure of steam or other gas, or employs a component that involves gas under pressure, consideration shall be given to the possibility of explosion. The appliance is not acceptable unless its strength is acceptable with regard to any risk of explosion that may be involved.

35.3 Whether a guard, release, or similar part is required, and whether such a device is acceptable, shall be determined from an investigation of the complete appliance, its operating characteristics, and the likelihood of a risk of injury to persons resulting from a cause other than gross negligence. The investigation shall include consideration of the results of malfunction or breakdown of any one component, but not more than one component at a time unless one event contributes to another. If the investigation shows that malfunction or breakdown of a particular component can result in a risk of injury to persons, that component shall be investigated for reliability. The investigation of a switch or other component in a safety circuit is to include at least 100,000 cycles of operation, unless the safety circuit is known to be reliable. An interlock shall comply with the requirements in Interlocks, Section 41.

35.4 A lamp emitting light in the ultraviolet frequency range shall be housed in an enclosure that will not permit a person to view the lamp directly if such viewing could result in an injury. An appliance employing an ultraviolet lamp shall be marked in accordance with 67.2.1. A photoflash lamp may normally be viewed without involving a risk of injury.

35.5 If an automatically-reset protective device is employed in an appliance, the automatic restarting shall not result in a risk of injury to persons.

35.6 The requirement in 35.5 requires the use of an interlock in the appliance if moving parts can present a risk of injury upon the automatic restarting of a motor.

35.7 A condenser lens shall be enclosed to prevent the direct expulsion of glass resulting from shattering of the lens.

### **36 Sharp Edges**

36.1 An edge, a projection, a corner of an enclosure, an opening, a frame, a guard, a knob, a handle, or the like, of an appliance shall not be sufficiently sharp to constitute a risk of injury to persons in normal maintenance and use.

36.2 Whenever referee measurements are required to determine that a part as mentioned in 36.1 is not sufficiently sharp to constitute a risk of injury to persons, the method described in the Standard for Test for Sharpness of Edges on Equipment, UL 1439, is to be employed.

### **37 Enclosure of Moving Parts**

37.1 The rotor of a motor, a pulley, a belt, a gear, a fan, a folding mechanism, or other moving part that could cause injury to persons, shall be enclosed, guarded, or an interlock provided so as to reduce the risk of unintentional contact. An interlock shall comply with the requirements in Interlocks, Section 41.

No Text on This Page



37.2 Other than as provided in 37.4(b), a moving part that may involve a risk of injury to persons shall comply with the requirements specified in 7.1.2 and shall be considered with regard to:

- a) The degree of exposure necessary to perform its intended function;
- b) The sharpness of the moving part;
- c) The risk of unintentional contact with the moving part;
- d) The speed of the moving part; and
- e) The risk that a part of the body could be endangered or that clothing could be entangled, resulting in a risk of injury to persons.

The above factors are to be considered with regard to both intended operation of the product and reasonably foreseeable misuse.

37.3 A manual or automatic feeding or cutting mechanism shall be constructed or guarded to reduce the risk or necessity for fingers of the operator to be in an area in which they could be injured.

37.4 With reference to 37.3, the cutting mechanism is acceptably recessed if:

- a) The probe described in Figure 7.1 cannot be made to touch the cutter or
- b) The average inside diameter (one-half the sum of the maximum and minimum dimensions) of the throat of a hopper or tubular feeding opening for manual feeding is not more than 2-1/2 inches (63.5 mm), and the cutters are recessed at least 4 inches (102 mm) below the plane of the opening.

## 38 Stability

38.1 An appliance, under all conditions of user servicing and during its intended use, shall not become mechanically unstable to the degree that it creates a risk of injury to the operator.

38.2 Other than the tests described in 38.3 and 38.4, the details of tests to determine lack of mechanical stability are not specified because of the differences in appliances. Among the factors that shall be considered are:

- a) The number of gates or doors that can be extended or opened at any one time on one side of an appliance before the appliance starts to tip;
- b) The risk that the appliance is capable of being installed without being fastened securely to a supporting surface; and
- c) The necessity for application of an additional weight or moment to the appliance – for example, climbing or leaning on or over the appliance – during normal use or user servicing.

38.3 An appliance not intended to be secured in place – not bolted to other appliances or secured to the floor or other part of the building – shall not tip over when tilted 10 degrees from its normal, upright, freestanding operating position while all doors, covers, gates, drawers, and similar parts, are in place and closed and casters, if any, are in their most disadvantageous position.

38.4 A freestanding unit more than 39-3/8 inches (1.00 m) high and weighing more than 55.1 pound (25.0 kg) shall not tip over when a force equal to one-fifth the weight of the unit, but not more than 56.2 pound (250 N), is applied in any direction, except upward, at a height not exceeding 78-3/4 inches (2.00 m) from the floor. For this test, all doors, drawers, frames, and similar parts, that can be opened for operator or service personnel are to be opened and in the most unfavorable position. Separate tests may be performed when operator and service extensions are different or when stabilizers are employed in accordance with 38.5.

38.5 A stabilizing means may be used to improved stability when doors, drawers, and similar parts, are opened. The stabilizing means shall be automatic in operation or interlocked when associated with operator use. For service personnel, if it is not automatic in operation, conspicuous marking shall be provided to caution the personnel on its use. See 67.12.1.

### **39 Strength of Handles**

39.1 A handle, strap, grip, or recess provided on an appliance shall withstand a force of four times the weight of the appliance without damage to the handle, its securing means, or that portion of the enclosure to which the handle is attached.

39.2 To determine whether an appliance complies with the requirement in 39.1, the handle and the means of securing the handle to the appliance are to be subjected to one application of a force of four times the weight of the appliance. The load is to be uniformly applied over a 3 inch (76 mm) width at the center of the handle without clamping. The load is to be started at zero and gradually increased so that the test value is attained in 5 – 10 seconds; the test value is to be maintained for 1 minute. If an appliance has more than one handle and cannot be carried by one handle the force is to be distributed between the handles. The distribution of forces is to be determined by measuring the percentage of the appliance weight sustained by each handle with the appliance in its intended carrying position. If an appliance is furnished with more than one handle and can be carried by only one handle, each handle is to withstand the total force.

### **40 Glass Parts**

40.1 A glass part that is not of the required enclosure and has:

- a) An area greater than 1 square foot (0.093 m<sup>2</sup>) or
- b) A major dimension greater than 18 inches (457.2 mm)

shall not be displaced, broken, or shattered (either totally or in part) from its mounting in a manner that may result in skin-lacerating injuries when tested as described in 40.2.

40.2 A glass part, as described in 40.1, shall withstand a single impact of 2.5 foot-pounds (3.39 J). The impact shall be applied by means of a smooth, solid, steel sphere 2 inches (51 mm) in diameter and weighing approximately 1.18 pounds (535 g). The sphere is to fall freely from rest so as to impact any area of the glass accessible to the ball.

### **41 Interlocks**

41.1 A moving part that is capable of causing injury to a person is considered to be guarded if protected by a cover with an interlock that complies with one of the following conditions:

- a) The part stops moving within 3 seconds after the cover is opened or
- b) The interlock prevents the cover from being opened until the part stops moving.

41.2 Operation of an interlock in normal use shall not inconvenience the operator so as to encourage deliberate defeat of the interlock.

41.3 An interlock shall be located so that unintentional operation is unlikely. The interlock shall be located so that it cannot be actuated by the probe illustrated in Figure 7.1. The interlock shall not be readily deflectable without damaging the appliance, or making wiring connections or alterations.

41.4 An interlock switch that is required to reduce a risk of electric shock or injury to persons shall withstand 100,000 cycles of operation controlling a load not less than that controlled in the appliance, and shall function normally upon completion of the test.

41.5 An interlock that is required to reduce the risk of electric shock of a cord-connected product shall open all supply conductors.

41.6 The requirements for interlocks, for access to lasers, are illustrated in Figure 41.1. Reference to the Code of Federal Regulations, 21CFR 1040, shall be made for Product Classifications and Label Wording requirements. References to labels shall be considered permanent markings and comply with the requirements of Marking, General, Section 65.

41.6 added April 9, 1999

**Figure 41.1**  
**Laser product safety interlock requirements**

Figure 41.1 added April 9, 1999

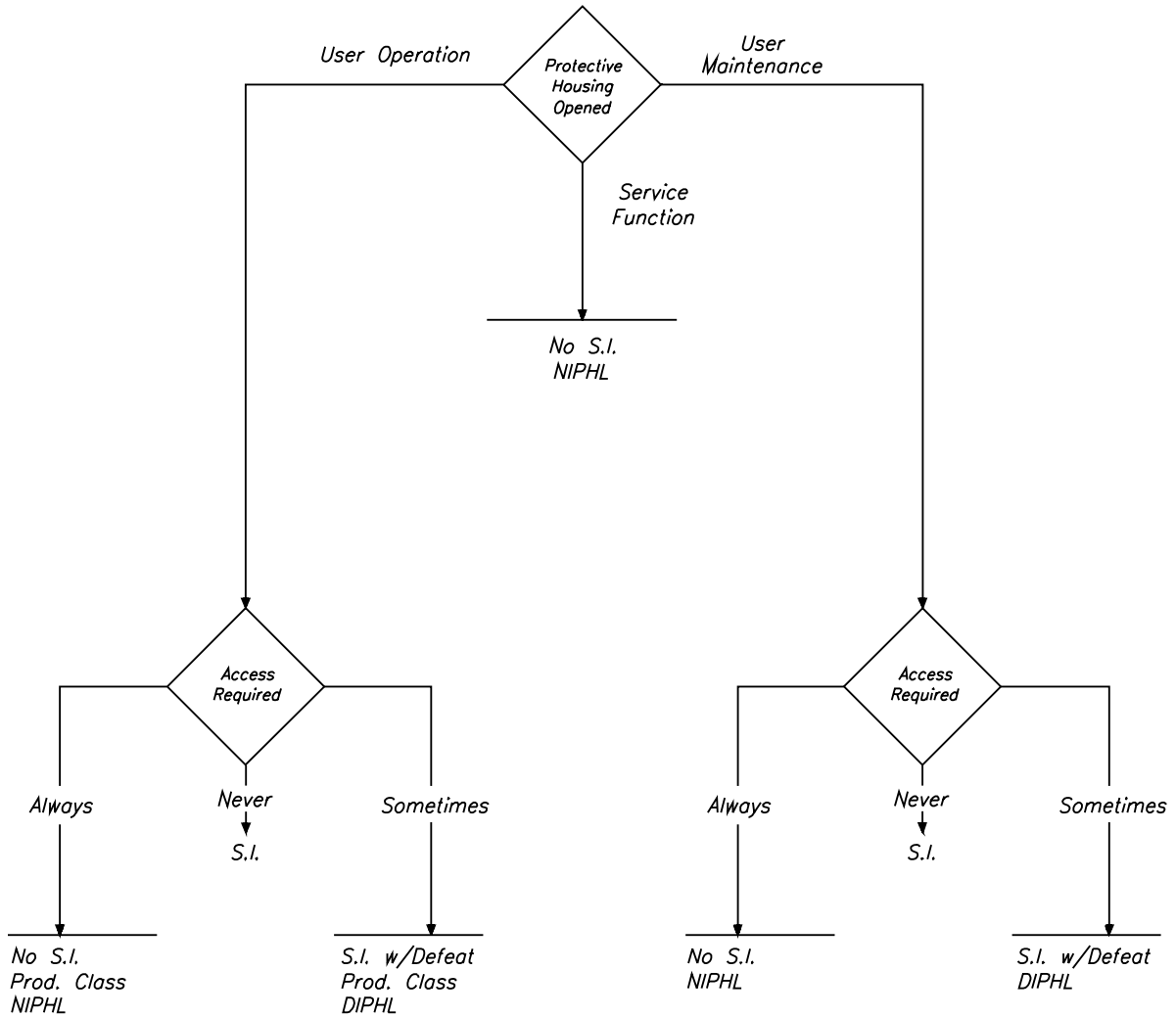

*Abbreviations:*

- S.I.*                    –Safety Interlock  
*Prod. Class*        –Interior level determines product classification (if higher than exterior level).  
*NIPHL*               –Label for Non–interlocked protective housing  
*DIPHL*               –Label for Defeatably–interlocked protective housing

S4091

41.7 With reference to 41.6, compliance of laser products with the Code of Federal Regulations (CFR), Title 21, Part 1040, shall be determined by:

- a) Determining the Class of laser (as defined by the CFR) from the manufacturers required documentation, such as the Center for Devices and Radiological Health (CDRH) report, markings and labels, or similar documentation;
- b) Verifying that the manufacturer's markings and labels, having the information specified in the CFR, are affixed on the laser product (as defined in the CFR);
- c) Determining that the corresponding construction features, such as protective housing, interlocks, and similar features, are provided in accordance with the CFR; and
- d) Determining that the resulting construction complies with the construction requirements of this standard.

41.7 added July 11, 2001

## 42 Surface Temperatures

42.1 During the temperature test, the temperature of a surface that may be contacted by the user shall not be more than the value specified in Table 42.1. The test is to be conducted as described in the Temperature Test, Section 52.

42.2 A nonmetallic material that is plated or clad with metal having a thickness not more than 0.005 inch (0.13 mm) is to be evaluated as a nonmetallic part.

42.3 An enclosure surface that is not known to be hot due to proximity to a source of heat may exceed the temperature limits specified in Table 42.1(2) but shall not exceed the limits specified in Table 42.1(3), if it is permanently marked in accordance with 67.6.1.

42.4 An air-exhaust grille may exceed the temperature limits specified in Table 42.1(3) if a marking in accordance with 67.6.1 is permanently affixed near the grille.

**Table 42.1**  
**Maximum surface temperatures**

Location	Composition of surface <sup>a</sup>			
	Metal,		Nonmetallic,	
	°C	(°F)	°C	(°F)
1. An enclosure surface, including a handle and a knob, that is grasped for lifting, carrying, or holding the appliance	50	122	60	140
2. An enclosure surface that is not known to be hot due to proximity to a source of heat <sup>b</sup>	60	140	85	185
3. An enclosure surface, other than a heating function surface and an air exhaust grille <sup>c</sup> , known to be hot due to proximity to a source of heat.	70	158	95	203
<sup>a</sup> See 42.2. <sup>b</sup> See 42.3. <sup>c</sup> See 42.4.				

### 43 Cord Flexing

43.1 To determine whether the cord and cord guard (if provided) are acceptable, the tests described in 43.2 – 43.6 are to be conducted. During the test, the cord shall not develop an open circuit and there shall be no exposure of an uninsulated conductor strand.

Added 43.1 effective April 9, 2000

43.2 The cord and cord guard (if provided) are to be conditioned for 96 hours in an oven maintained at a temperature of 70°C (158°F), or 10°C (18°F) more than the maximum temperature observed during the normal temperature test, whichever is greater.

Added 43.2 effective April 9, 2000

43.3 A power-supply cord shall withstand 5,000 cycles of flexing at the cord entrance to the tool. Flexing shall be performed at a rate not exceeding 10 cycles per minute, unless agreeable to those concerned.

Added 43.3 effective April 9, 2000

43.4 Three samples are to be tested. Each sample is to be mounted so that the cord entrance point of the product is at the center of rotation. A 1-pound (0.45-kg) weight is to be attached to the cord between 3 feet (0.91 m) and 5 feet (1.52 m) from the cord entry point. Any additional cord beyond 5 feet is to be removed. Guides are to be provided 3 feet from the cord entry point to minimize bouncing or side-to-side motion of the cord. The weight is to be located so as not to interfere with the guides. When a short cord is employed, the additional length is to be obtained by using an attached extension cord that the manufacturer makes available. See Figure 43.1.

Added 43.4 effective April 9, 2000

43.5 Starting with the cord in a vertical position and the cord entrance pointing downward, each cycle is to consist of rotating the entrance point 90 degrees to the horizontal position, rotating back 180 degrees to the opposite horizontal position, and then back to the vertical position, for a total rotation of 360 degrees. Rotation is to be smooth with no sudden starts or stops.

Added 43.5 effective April 9, 2000

43.6 After flexing:

- a) Each current-carrying conductor shall be capable of carrying its rated ampacity (for the size conductor) as specified in the National Electrical Code, ANSI/NFPA 70, for 2 minutes without interruption. A grounding conductor, if provided, shall be capable of carrying twice its rated ampacity for 2 minutes without interruption;
- b) Following the test in 43.6(a), there shall be no dielectric breakdown when a potential of 1000 V plus twice the rated voltage of the tool is applied for 1 minute between the individual conductors of the cord with the internal connections to the tool severed and insulated, and between live parts and accessible metal parts; and
- c) There shall be no breakage of a cord jacket or individual conductor insulation. No strands shall be exposed through conductor insulation.

Added 43.6 effective April 9, 2000

**Figure 43.1**  
**Cord flexing**

Added Figure 43.1 effective April 9, 2000

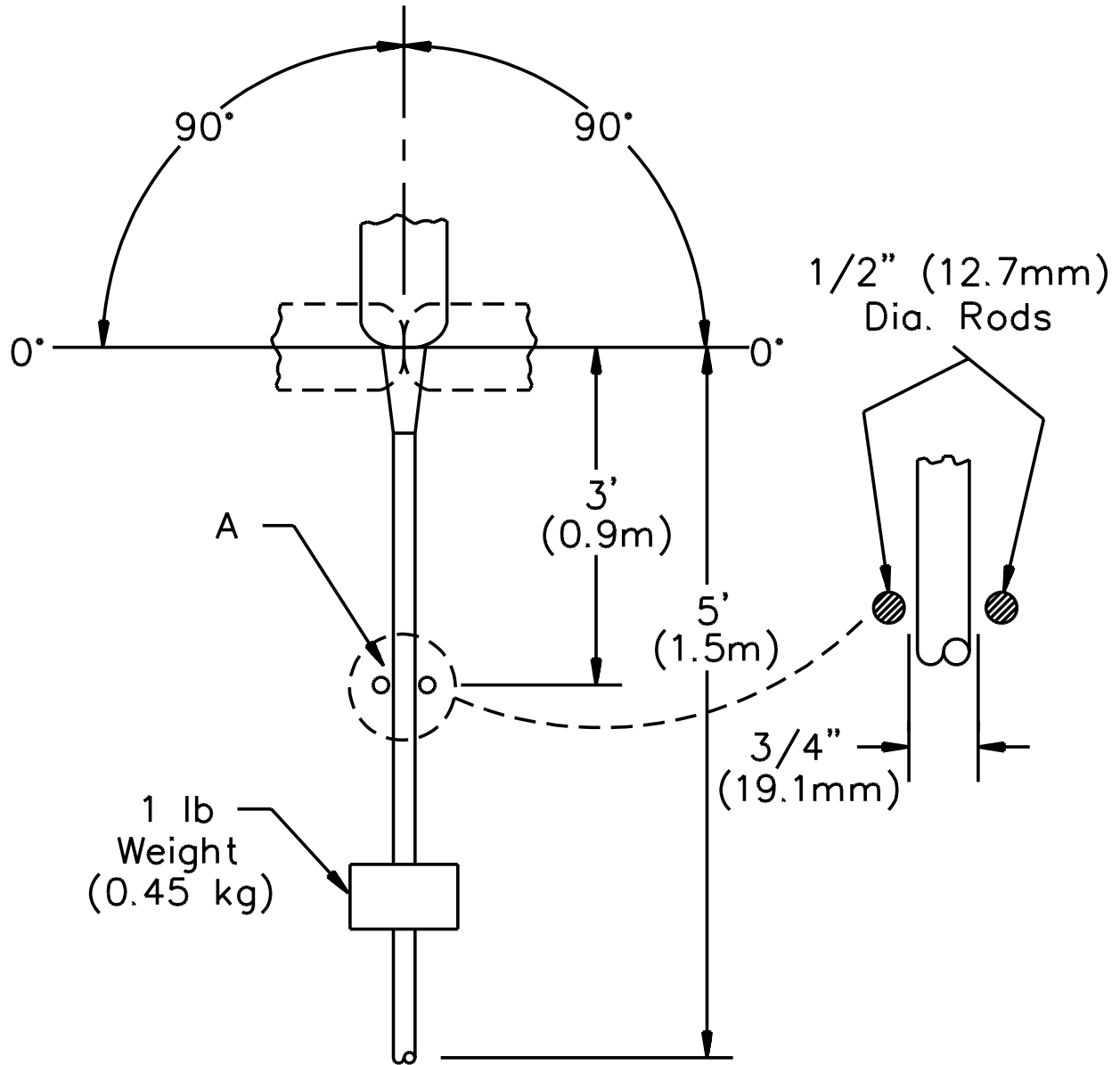

A – Portions of the cord damaged by contact with the guides or attachment of the weight may be removed prior to the electrical tests.

S2864

## 44 Marking

44.1 A projector using carbon arc, xenon, or other light source equipment that develops gases, dust, or radiation that may cause injury to persons shall be marked as specified in 66.9.1.

## PERFORMANCE

### 45 General

45.1 Unless otherwise specified, the voltage for tests shall be as indicated in Table 45.1.

45.2 Equipment with one frequency rating is to be tested at that frequency. Equipment with a dual frequency rating is to be tested at 60 Hz if 60 Hz is in the rating and may also be tested at the second frequency.

**Table 45.1**  
**Voltage for tests**

Marked voltage rating	Test voltage
105 – 130	Maximum marked voltage but not less than 120 volts
210 – 260	Maximum marked voltage but not less than 240 volts
420 – 520	Maximum marked voltage but not less than 480 volts
520 – 600	600 volts
Other than as specified above	Maximum marked voltage
Battery-operated appliance	Maximum battery voltage

### 46 Resistance of Grounding Circuit

46.1 The resistance between the point of connection of the equipment grounding means, at or within an appliance, and any other point in the grounding circuit shall not exceed 0.1 ohm.

46.2 An impedance-measuring instrument may be used to determine whether an appliance complies with the requirement in 46.1; or, in place of this instrument, an alternating current of at least 25 A from a power supply of not more than 12 V is to be passed from the point of connection of the equipment grounding means to a point in the grounding circuit, and the resulting drop in potential is to be measured between the two points. For a cord-connected product with a grounding-type attachment plug and grounding conductor, the connection of the equipment grounding means is considered to be the point on the appliance where the grounding conductor of the cord is attached. The resistance in ohms is to be determined by dividing the drop in potential in volts by the current in amperes passing between the two points.

46.3 A conductor smaller than that specified in 13.1.9 or 13.2.4 may be used if the bonding or grounding connection does not open when carrying twice the current equal to the rating of the branch-circuit overcurrent device for the interval specified in Table 46.1.

Added 46.3 effective April 9, 2000



**Table 46.1**  
**Duration of current for bonding-conductor test**

Added Table 46.1 effective April 9, 2000

Overcurrent device rating, amperes	Minimum current flow duration, minutes
30 or less	2
31 – 60	4
61 – 100	6

## 47 Leakage Current and Shock Current Tests

### 47.1 General

47.1.1 All parts of a single-phase, cord-connected appliance rated for a nominal 240 V or less that are accessible during normal use are to be tested for leakage current and during user servicing are to be tested for shock current. The currents from these parts are to be measured to the grounded supply conductor individually as well as collectively where simultaneously accessible and from one part, or group of parts, to another part, or group of parts where simultaneously accessible. Parts are considered to be simultaneously accessible when they can be contacted by one or both hands of a person at the same time. For the purpose of this measurement, one hand is considered to be able to simultaneously contact parts that are within a 4 by 8 inch (102 by 203 mm) rectangle. Parts that can be contacted simultaneously by a person having a reach of 6 feet (1.83 m) are considered to be touchable by both hands.

47.1.2 If the appliance has a direct-current rating, measurements are to be made with the appliance connected in turn to each side of a 3-wire, direct-current supply circuit.

47.1.3 Insulation, such as that usually used in a location as specified in (a) – (f), is to be short- or open-circuited during the test:

- a) Between the voice coil and the frame of a speaker.
- b) Between live parts and the metal frame of a phonograph pick-up cartridge.
- c) Between the two channels of a stereophonic phonograph pick-up cartridge.
- d) Between the heater and cathode elements of a vacuum tube.
- e) Between any two adjacent elements of a vacuum tube, between the elements of an electrolytic capacitor.
- f) Between the elements of a solid-state component – for example, a diode, a transistor, an integrated circuit, and a similar device.

*Exception: A solid-state component, the breakdown of which can be relied upon not to result in a risk of electric shock is not required to be short- or open-circuited during the test.*

47.1.4 Current measurements are to be made:

- a) With any operating control or adjustable control that is considered subject to user operation in all possible positions of contact and
- b) Either with or without tubes, separable connectors, and similar devices in place.

47.1.5 If a conductive surface other than metal is used for the enclosure or part of the enclosure, the leakage current is to be measured using a metal foil with an area of 10 by 20 centimeters in contact with the surface. If the surface is less than 10 by 20 centimeters, the metal foil is to be the same size as the surface. The metal foil is not to remain in place long enough to affect the temperature of the appliance.

## 47.2 Leakage current

47.2.1 A cord-connected product rated for a nominal 250-volt or less supply shall be tested in accordance with 47.2.2 – 47.2.5. Leakage current shall not be more than:

- a) 0.5 MIU for a two-wire cord- and plug-connected appliance,
- b) 0.5 MIU for a three-wire (including grounding conductor) cord- and plug-connected portable appliance, and
- c) 0.75 MIU for a three-wire (including grounding conductor) cord- and plug-connected stationary or fixed appliance.

*Exception No. 1: The leakage current of an appliance incorporating a sheath type heating element is to be monitored during heat-up and cool-down and shall not exceed 2.5 MIU during the first 5 minutes of energizing the appliance. At the end of this time, the leakage current shall be not more than the 0.5 MIU or 0.75 MIU limit, as applicable.*

*Exception No. 2: Conductive parts of an appliance that complies with the following conditions and that have a leakage current greater than specified in (a), (b), or (c) shall have a leakage current from simultaneously accessible parts to the grounded supply conductor no greater than 3.5 MIU. The leakage current between simultaneously accessible parts shall not exceed 0.5 MIU.*

- a) *The product is equipped with a grounding type supply cord and plug;*
- b) *There is a low probability that a path for available current through the body will exist in the expected environment. If the available current flows to ground, this will involve consideration of the probability that the user will be grounded during the use of the product;*
- c) *There is a low probability that high-leakage, conductive parts are capable of being contacted during normal use of the product;*
- d) *The probability of injury resulting from an involuntary reaction is small.*

*Exception No. 3: For an appliance that upon loss-of-grounding, dependably disconnects all sources that can produce leakage current, the leakage current to ground shall not exceed 5 MIU with the grounding conductor open and with the loss-of-grounding circuit disabled. The leakage current between simultaneously accessible parts on the appliance shall not be more than 5 MIU.*

*a) The product requires electromagnetic interference (EMI) suppression filtering for compliance with other requirements, such as Federal Communications Commission (FCC) Regulations.*

Revised 47.2.1 effective April 9, 2000

47.2.2 All accessible conductive parts are to be tested for leakage currents. Leakage currents from these parts are to be measured to the grounded supply conductor individually as well as collectively if simultaneously accessible, and from one part to another if simultaneously accessible. A part is considered to be accessible unless it is guarded by an enclosure that is acceptable for protection against the risk of electric shock. Conductive parts are considered to be simultaneously accessible if they can be readily contacted by one or both hands of a person at the same time. These measurements do not apply to terminals operating at voltages that are not considered to involve a risk of electric shock. If all accessible conductive parts are bonded together and connected to the grounding conductor of the power-supply cord, the leakage current can be measured between the grounding conductor of the product and the grounded supply conductor. If accessible dead-metal parts of a product are connected to the neutral supply conductor, this connection is to be opened during the test.

Revised 47.2.2 effective April 9, 2000

47.2.3 When a conductive part other than metal is used for an enclosure or part of an enclosure, leakage current is to be measured using a metal foil with an area of 10 by 20 centimeters in contact with the surface. If the conductive surface has an area less than 10 by 20 centimeters, the metal foil is to be the same size as the surface. The metal foil is to conform to the shape of the surface but is not to remain in place long enough to affect the temperature of the product.

Revised 47.2.3 effective April 9, 2000

47.2.4 Typical measurement circuits for leakage current with the ground connection open are illustrated in Figure 47.1. The measurement instrument is defined in Figure 47.2. The meter that is actually used for a measurement is only required to indicate the same numerical value for a particular measurement as would the defined instrument; it is not required to have all the attributes of the defined instrument. Over the frequency range 20 Hz – 1 MHz with sinusoidal current, the performance of the instrument is to be as follows:

a) The measured ratio of  $V_1/I_1$  with sinusoidal voltages is to be as close as feasible to the ratio  $V_1/I_1$  calculated with the resistance and capacitance values of the measurement instrument shown in Figure 47.2 and

b) The measured ratio of  $V_3/I_1$  with sinusoidal voltages is to be as close as feasible to the ratio  $V_3/I_1$  calculated with the resistance and capacitance values of the measurement instrument shown in Figure 47.2.  $V_3$  is to be measured by the meter M in the measuring instrument. The reading of meter M in RMS volts can be converted to MIU by dividing the reading by 500 ohms and then multiplying the quotient by 1,000. The mathematic equivalent is to multiply the RMS voltage reading by 2.

Revised 47.2.4 effective April 9, 2000

**Figure 47.1**  
**Typical leakage current measurement circuits**

Revised Figure 47.1 effective April 9, 2000

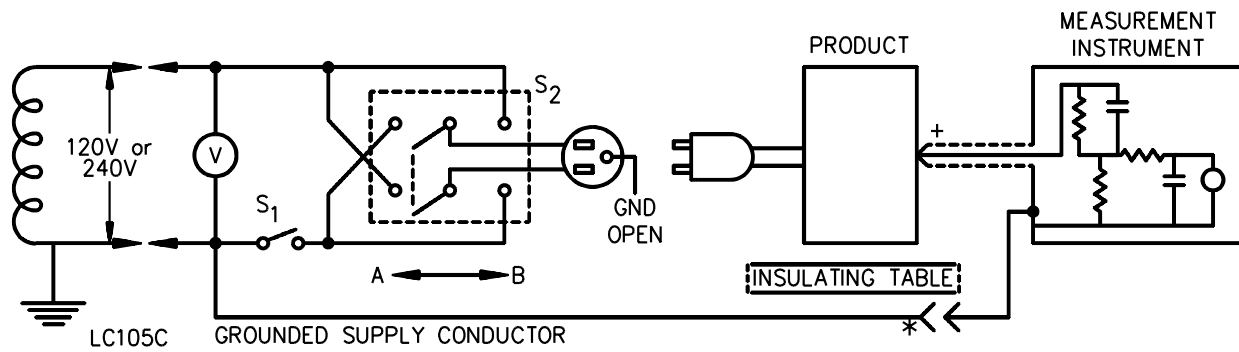

Product intended for connection to a 120-volt or an end-grounded, 3-wire, 240-volt power supply.

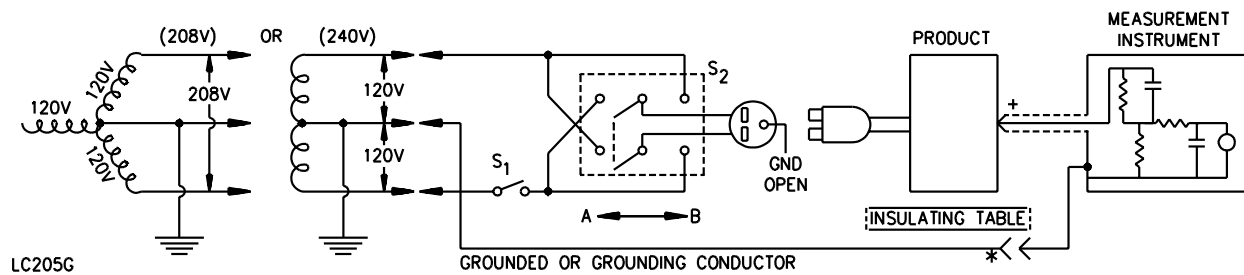

Product intended for connection to a 3-wire, 120/208-volt grounded neutral or 3-wire, 240-volt power supply. See 47.2.6 and 47.2.7.

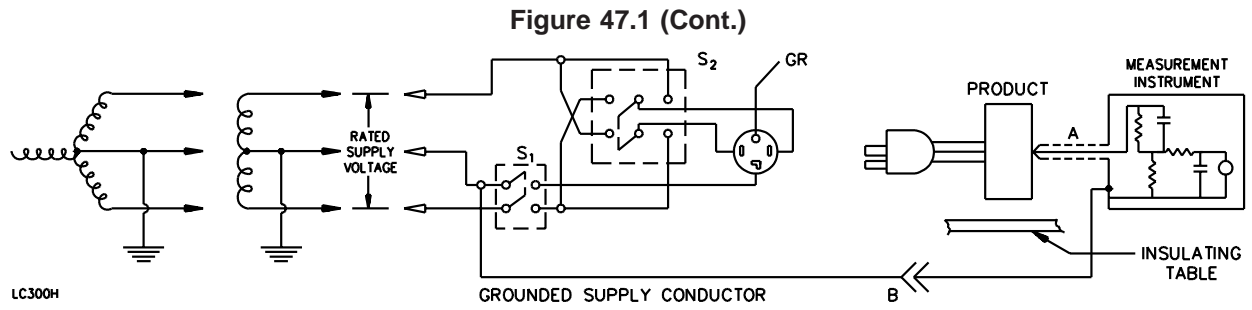

Appliance intended for connection to a 4-wire grounded neutral supply, up to 600 volts.

+ – Probe with shielded lead.

\* – Separated and used as a clip when measuring currents from one part of appliance to another.

**Figure 47.2**  
**Measurement instrument for reaction (leakage) current**

Added Figure 47.2 effective April 9, 2000

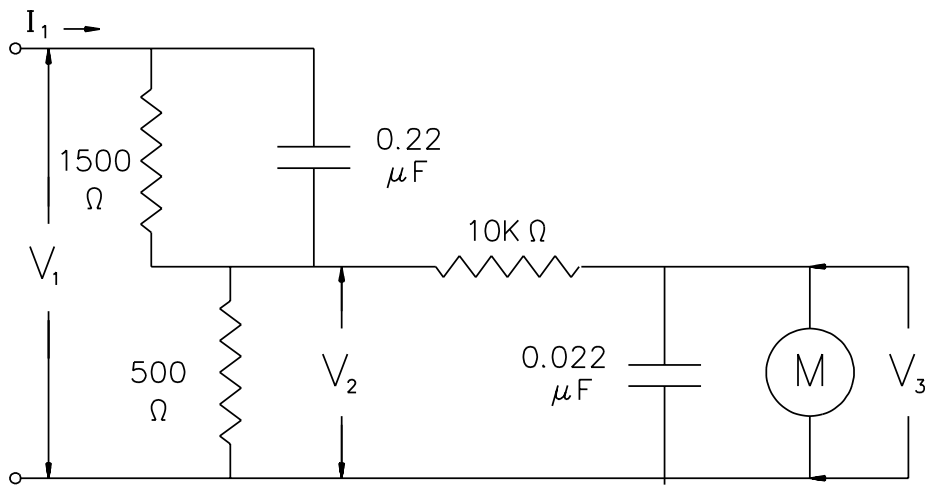

S3263C

Note – Detailed specifications and guidance for the calibration of this instrument are given in the American National Standard for Leakage Current for Appliances, ANSI C101-1992.

47.2.5 Unless the measurement instrument is being used to measure leakage current from one part of a product to another, it is to be connected between accessible parts and the supply conductor connected to ground (the grounded or grounding conductor) that has the least extraneous voltages introduced from other equipment operated on the same supply. For products rated 120 volts or 240 volts, with one supply conductor grounded, this is likely to be the grounded supply conductor.

Revised 47.2.5 effective April 9, 2000

47.2.6 When there is no grounding conductor connected to the product under test (for example, a 240-volt, 2-conductor product supplied by a 120-/240-volt source), then the instrument return lead may be connected to either the grounded or grounding conductor of the supply depending on the other electrical loads connected to the branch circuit and operating at the time the test is conducted. Use the conductor introducing the least extraneous voltage, as indicated by the lowest leakage current reading. In environments having considerable extraneous voltage introduced, an isolating transformer can reduce the effects of extraneous voltages.

Added 47.2.6 effective April 9, 2000

47.2.7 A sample of a product is to be tested for leakage current starting with the as-received condition – the as received condition being without prior energization, except as may occur as part of the production-line testing. The supply voltage is to be adjusted to rated voltage. The sequence is to be as follows, with reference to the Figure 47.1 measurement circuit:

- a) With switch  $S_1$  open, the product is to be connected to the measurement circuit. Leakage current is to be measured using both positions of switch  $S_2$ , and with the product switching devices in all their normal operating positions.
- b) Switch  $S_1$  is then to be closed, energizing the product. Within 5 seconds, the leakage current is to be, measured using both positions of switch  $S_2$  and with the product switching devices in all their normal operating positions.
- c) Leakage current is to be monitored until thermal stabilization. Both positions of switch  $S_2$  are to be used in determining this measurement. Thermal stabilization is to be obtained by operation as in the normal temperature test.
- d) The leakage current is also to be monitored with switch  $S_1$  open while the product is at operating temperature and while cooling.

Added 47.2.7 effective April 9, 2000

47.2.8 Normally, a sample is to be subjected to the entire leakage current test, as specified in 47.2.7, without interruption for other tests. With the concurrence of those concerned, the leakage current test may be interrupted to conduct other nondestructive tests.

Added 47.2.8 effective April 9, 2000

### 47.3 Shock current

47.3.1 An electric shock is considered likely to occur at any part exposed only during user service if the open-circuit potential between the part and earth ground or any other accessible part is more than 42.4 V peak for an indoor appliance and where wet contact is not likely to occur; or 21.2 V peak for an outdoor appliance or where wet contact is likely to occur; and any of the following:

- a) The continuous current flow through a 500-ohm resistor connected between any part and either earth ground or any other accessible part, exceeds the limits specified in Table 47.1; or

- b) The combination of magnitude and duration of peak current flow exceeds the limits specified in 47.4.1; or
- c) The combination of capacitance and voltage exceeds the limits specified in 47.6.1.

**Table 47.1**  
**Electric shock – appliance**

Frequency, hertz <sup>a</sup>	Maximum current through a 500-ohm resistor (milliamperes peak)
0 – 100	7.1
500	9.4
1000	11.0
2000	14.1
3000	17.3
4000	19.6
5000	22.0
6000	25.1
7000 or more	27.5

<sup>a</sup> Straight-line interpolation between adjacent values in the table can be used to determine the maximum acceptable current values corresponding to frequencies not shown in the table. The above table applies to repetitive waveforms of nonsinusoidal or sinusoidal current.

#### 47.4 Transient electric shock

47.4.1 The duration of a transient current (unidirectional or alternating) through a 500-ohm resistor, connected between any part exposed only during user servicing and earth ground or any other accessible part, shall satisfy the following equation:

$$T \leq \left( \frac{20\sqrt{2}}{I} \right)^{1.43}$$

*in which:*

*T is the duration, measured in seconds, from the time that the instantaneous value of the current first exceeds 7.1 mA, until the time that the current falls below 7.1 mA for the last time and*

*I is the peak current in milliamperes.*

The interval between occurrences shall be equal to or greater than 60 seconds if the current is repetitive. Typical calculated values appear in Table 47.2. The peak current shall not exceed 809 mA regardless of duration.

**Table 47.2**  
**Electric shock – transient**

Maximum current in milliamperes peak through 500-ohm resistor	Maximum acceptable time in seconds of envelope containing excursions greater than 7.1 milliamperes peak
Less than 7.1	Not applicable
7.1	7.22
8.5	5.58
10.0	4.42
12.5	3.21
15.0	2.48
17.5	1.99
20.0	1.64
22.5	1.39
25.0	1.19
30.0	0.919
40.0	0.609
50.0	0.443
60.0	0.341
70.0	0.274
80.0	0.226
90.0	0.191
100.0	0.164
150.0	0.092
200.0	0.061
250.0	0.044
300.0	0.034
350.0	0.027
400.0	0.023
450.0	0.019
500.0	0.016
600.0	0.012
700.0	0.010
809.0	0.0083
Greater than 809.0	0



## 47.5 Stored energy electric shock

47.5.1 The maximum capacitance between capacitor terminals that are accessible during user servicing shall satisfy the following equations:

$$C = \frac{88,400}{E^{1.43}(\log_e E - 1.26)} \quad \begin{array}{l} \text{for } E \text{ equal to or less} \\ \text{than 400 volts} \end{array}$$

$$C = 35,288E^{-1.5364} \quad \text{for } E \text{ greater than 400 volts but equal to or less than 1000 volts}$$

*in which:*

*C is the maximum capacitance of the capacitor terminals in microfarads and*

*E is the potential in volts across the capacitor prior to discharge.*

E is measured 5 seconds after the capacitor terminals are accessible by the removal or opening of an interlock cover, or similar device. Typical calculated values appear in Table 47.3.

47.5.2 If the short-circuiting of an accessible part results in the discharge of a capacitor, thereby causing an instantaneous flow of current, the transient condition is to be considered with regard to 47.4.1.

## 47.6 Tube interchange and substitution

47.6.1 The interchange of any electron tube used in an appliance, or the substitution of a tube used in the appliance with its glass or metal equivalent of like designation that is used in the appliance, shall not result in a risk of electric shock. Any electron tube used in the appliance is to be inserted in any electron tube socket in the appliance that accommodates it without modification.

## 47.7 Standardized pin/socket arrangements

47.7.1 In addition to the evaluation specified in 47.6.1, certain industry standardized electron tube pin arrangements must be considered in cases where electric shock can result by connecting in production sufficient potential and current to a socket pin to which a shield or an electron tube metal envelope is supposed to be connected.

*Exception: When there are no electron tubes with metal shields or metal electron tubes employed in the appliance and there are no counterparts available where the shield or metal envelope is or might be connected to the particular pin reserved for such use.*

47.7.2 Appliances with audio output shall comply with the requirements for electric shock current in the Standard for Commercial Audio Equipment, UL 813, for commercial appliances, and the Standard for Radio Receivers, Audio Systems and Accessories, UL 1270, for household appliances.

**Table 47.3**  
**Stored energy shock current**

Potential across capacitance prior to discharge <sup>a</sup> , in volts	Maximum acceptable capacitance in microfarads
40,000	0.0030
35,000	0.0037
30,000	0.0047
25,000	0.0062
20,000	0.0087
15,000	0.0135
10,000	0.0252
7,000	0.0437
5,000	0.0732
4,000	0.103
3,000	0.160
2,500	0.212
2,000	0.299
1,500	0.465
1,250	0.616
1,000	0.868
900	1.02
800	1.22
700	1.50
600	1.90
500	2.52
400	3.55
380	3.86
360	4.22
340	4.64
320	5.13
300	5.71
280	6.40
260	7.24
240	8.27

Table 47.3 Continued on Next Page

Table 47.3 Continued

Potential across capacitance prior to discharge <sup>a</sup> , in volts	Maximum acceptable capacitance in microfarads
220	9.56
200	11.2
180	13.4
160	16.3
140	20.5
120	26.6
100	36.5
90	43.8
80	53.8
70	68.0
60	89.4
50	124
45	150
42.4	169
40	186 <sup>b</sup>
35	239 <sup>b</sup>
30	319 <sup>b</sup>
25	452 <sup>b</sup>
21.2	625 <sup>b</sup>
Less than 21.2	Any

<sup>a</sup> Straight line interpolation between adjacent values in the table may be used to determine the maximum allowable capacitance corresponding to voltages not shown in the table.

<sup>b</sup> Applies only to outdoor-use or where wet contact is likely to occur.

#### 48 Leakage Current Following Humidity Conditioning Test

48.1 A cord connected appliance rated for a nominal 240 V AC or less supply shall comply with the requirements for leakage current in 47.2.1, following conditioning described in 48.2.

48.2 To determine whether a product complies with the requirement in 48.1, a sample of the product is to be heated to a temperature just above 34°C (93°F) to reduce the risk of condensation of moisture during conditioning. The heated sample is to be placed in the humidity chamber and is to remain for 48 hours at a relative humidity of 88 ±2 percent at a temperature of 32 ±2°C (90 ±4°F). Following the conditioning, the sample is to be tested unenergized as described in 47.2.4(a). The sample is then to be energized and tested as described in 47.2.4(b). The test is to be discontinued when the leakage current stabilizes or decreases.

Revised 48.2 effective April 9, 2000

## 49 Operational Tests

49.1 Operation of an appliance as described in 49.2 shall not increase the risk of fire, electric shock, or injury to persons.

49.2 With reference to 49.1, an as-received sample of the appliance is to be set up or installed in accordance with the manufacturer's instructions. The appliance is to be:

- a) Operated in accordance with the manufacturer's instructions with regard to the intended uses of the appliance, including maintenance and cleaning, and with all accessories recommended by the manufacturer for use with the appliance;
- b) Manipulated as it would be in actual use, including manipulation of all controls and operation under the various loading conditions that can be expected; and
- c) Operated for a sufficient length of time or through a sufficient number of cycles so that all reasonably foreseeable complications are revealed.

## 50 Starting Current Test

50.1 When tested as described in 50.2, an appliance shall start and operate as intended on a branch circuit protected by a fuse that is of other than a time-delay type, and has a current rating corresponding to that of the branch circuit to which the appliance should be connected in accordance with the National Electrical Code, ANSI/NFPA 70. Tripping of an overload protector provided as part of the appliance or opening of the fuse is unacceptable.

*Exception: An appliance is not required to be tested if all three of the following conditions are satisfied:*

- a) The construction of the appliance or the nature of its use is such that the appliance is likely to be connected on the same branch circuit each time it is used;*
- b) The appliance starts and operates normally on a circuit protected by a time-delay fuse; and*
- c) The appliance is marked in accordance with 66.8.1.*

50.2 To determine whether an appliance complies with the requirement in 50.1, the appliance is to be started three times from standstill without causing the fuse to open. The appliance is to be at room temperature at the beginning of the test. Each start is to be made under conditions representing the beginning of intended operation – the beginning of the intended operating cycle in the case of an automatic appliance – and any motor is to be allowed to come to rest between successive starts.

## 51 Input Test

### 51.1 General

51.1.1 The current or wattage input to an appliance shall not be more than 110 percent of the marked value when the appliance is operated at maximum rated load as described in 51.2.1.1 – 51.2.14.1 while connected to a supply circuit of frequency and voltage as specified in Performance, General, Section 45.

## 51.2 Maximum normal load

### 51.2.1 General

51.2.1.1 In tests on an appliance, maximum normal load is considered to be that load which approximates as closely as possible the most severe conditions that may occur during use. It is not a deliberate overload except as if the conditions of actual use are likely to be somewhat more severe than the maximum load conditions that are recommended by the manufacturer of the appliance. Test loads that are determined to be close approximations of the most severe conditions during use are described in 51.2.1.2 – 51.2.13.1 for some common forms of appliances. However, an appliance having features not contemplated in these test procedures may be tested as necessary to meet the intent of these requirements.

51.2.1.2 A portable appliance that may be operated near a wall is to be placed so that the maximum projection of the back is in contact with a flat vertical wall of wood or comparable heat-insulating material, except that the spacing between the wall and the main surface of the back of the appliance is to be at least 1 inch (25.4 mm). Material such as rubber and felt is to be removed from supporting feet to the extent that it is likely to be worn off in normal use of the appliance. Elevation adjustments are to be set at the height that creates minimum ventilation. A cover that is likely to be closed during operation of the appliance is to be closed for the duration of the test.

### 51.2.2 Appliances with audio amplifiers

51.2.2.1 An appliance having its power input affected by signal input is to be operated with 1000-Hz sine-wave input and with all volume and tone controls adjusted to give maximum output. A matched load impedance is to be connected across the output of the appliance; speakers, if provided, are to be disconnected. The input-signal voltage is to be adjusted so that the appliance produces an audio output power equal to one-tenth for household equipment and one-third for commercial equipment of the maximum available undistorted sine-wave output power but not less than 1/2 watt per channel.

51.2.2.2 An amplifier is to be operated with the 1000-Hz signal applied to the first audio stage of the appliance.

51.2.2.3 The maximum undistorted output power is to be determined by visually examining the wave shape for clipping using an oscilloscope. If no clearly delineated clipping is visible, the maximum undistorted output power is defined as the power reading after the amplifier transconductance (the output current divided by the input signal voltage) or the voltage gain (the output voltage divided by the input voltage) has changed 10.0 percent. This is to be repeated for the range of audio load impedance taps and corresponding wattage ratings for the amplifier. If during this measurement, fuses, circuit breakers, limit switches, or other safety devices or circuits are actuated and prevent determination of maximum undistorted output power, then the protective device or protective circuit is to be defeated. If the measurement is still unattainable, the maximum undistorted output power is to be taken as the manufacturer's rated output power.

### 51.2.3 Projectors

51.2.3.1 A film strip projector or a slide projector is to be operated continuously until constant temperatures are reached. See 52.3.1. If the film strip can be advanced or the slide can be changed by means of a motor or a solenoid, this function is to be repeated every 5 seconds. If the projector has provision for automatically advancing the film strip or changing this slide, this function is to be repeated at the maximum automatic speed or every 5 seconds, whichever results in the maximum frequency of changes.

51.2.3.2 A motion picture projector is to be operated as intended with the largest reel of the film that the projector can accommodate to its completion. The film is then to be rewound on the projector and the cycle is to be repeated until constant temperatures are reached. If the projector has a variable speed control, the control is to be set at a speed that results in maximum temperatures.

51.2.3.3 An opaque or overhead projector is to be operated in its intended manner, continuously displaying a printed page, transparency, or other material it is intended to project.

#### 51.2.4 Theater projectors

51.2.4.1 A theater projector is to be operated continuously with film until constant temperatures are reached.

#### 51.2.5 Enlargers

51.2.5.1 An enlarger is to be operated 1 minute on, then 1 minute off until constant temperatures are reached. The enlarger is to be provided with the maximum size lamp specified by the manufacturer's marking.

#### 51.2.6 Photoflash equipment

51.2.6.1 A household photoflash unit is to be operated at the maximum rate of operation specified in the instructions for the unit until constant temperatures are reached. The total number of flashes is not to exceed 36 or the maximum film capacity of the system, whichever is less.

*Exception: If the instructions do not specify a rate of operation, the unit is to be operated at the rate of approximately one operation – flash and recharge – every 30 seconds until constant temperatures are reached.*

51.2.6.2 A commercial photoflash unit is to be operated flashing at:

- a) The maximum rate of operation for full light output. The duty cycle is to be 5 minutes flashing, 5 minutes standby, for 3 hours and

*Exception: The operation is not to be faster than 12 flashes per minute unless the instruction manual specifies that the unit is capable of faster operation.*

- b) A rate of four flashes per minute for 3 hours, following the operation required by (a).

#### 51.2.7 Film rewinders

51.2.7.1 A film rewriter is to be operated through continuous operations of rewinding and reel changes until constant temperatures are reached.

#### 51.2.8 Film and print cleaners, dryers, and processors

51.2.8.1 A film or print cleaner, a film or print dryer, or a film or print processor is to be operated continuously until constant temperatures are reached:

- a) In the standby mode and
- b) Processing film or prints at the maximum rate.

### 51.2.9 Chemical replenishers

51.2.9.1 A chemical replenisher is to be operated while connected to a processor cycling at its maximum rate, or under conditions simulating such operation, until constant temperatures are reached.

### 51.2.10 Phototimers

51.2.10.1 A phototimer is to be operated continuously until constant temperatures are reached.

### 51.2.11 Photographic timers

51.2.11.1 A photographic timer is to be operated continuously at a rate representative of its normal duty cycle, controlling the maximum intended loads, until constant temperatures are reached.

### 51.2.12 Cameras and combination camera/photoflash equipment

51.2.12.1 A camera shutter solenoid, lamp, or similar part, is to be cycled at the maximum normal rate, allowing time for changing film and copy material, until constant temperatures are reached.

### 51.2.13 Film drum agitators

51.2.13.1 A film drum agitator is to be operated continuously unless provided with a momentary contact switch that senses the presence of the chemical drum, in which case the unit is to be operated at a duty cycle of 10 minutes on, 30 seconds off, representing processing with diluted chemicals. Operation is to continue until constant temperatures have been reached.

### 51.2.14 Silver recovery units

51.2.14.1 A silver recovery unit is to be operated at a constant load equal to the maximum plating current.

### 51.2.15 Laser imagers

51.2.15.1 A laser imager shall be operated at the maximum rate of operation continuously until thermal equilibrium.

Added 51.2.15.1 effective April 9, 2000

### 51.2.16 Film loader/unloader

51.2.16.1 A film loader/unloader shall be operated at the maximum rate of operation continuously until thermal equilibrium.

Added 51.2.16.1 effective April 9, 2000

## 52 Temperature Test

### 52.1 General

52.1.1 An appliance is to be subjected to the temperature test described in 52.4.1 – 52.4.3 at maximum load as described in 51.2.1.1 – 51.2.16.1. The appliance shall not reach a temperature at any point high enough to cause a risk of fire, to damage any material used, or to exceed the temperatures given in Table 52.1 at specific points. See 52.1.2.

52.1.2 The maximum acceptable sealing compound temperature, when corrected to a 25°C (77°F) less than the softening point of the compound as determined in accordance with the Test Method for Softening Point by Ring-and-Ball Apparatus, ASTM E28.

52.1.3 There is no temperature limit applicable to unimpregnated glass fiber, beads, or inorganic material, or similar material, employed as conductor insulation.

## 52.2 Ambient temperatures

52.2.1 The temperature values specified in Table 52.1 are based on an assumed ambient temperature of 25°C (77°F); however, the test may be conducted at any ambient temperature within the range of 10 – 40°C (50 – 104°F). Each observed temperature is to be corrected by the addition of the difference between 25°C and the actual ambient temperature if the test is conducted at an ambient temperature less than 25°C; and other than as indicated in 52.2.2, each observed temperature is to be corrected by the subtraction of the difference between 25°C and the actual ambient temperature if the test is conducted at an ambient temperature more than 25°C.

52.2.2 If the temperature at a point is affected by a fixed-temperature physical process – such as the boiling of water – or by an automatic temperature control, and if the test is conducted at an ambient temperature more than 25°C (77°F), the observed temperature at such points is not to be corrected.

52.2.3 If the test is conducted at an ambient temperature of other than 25°C (77°F), and if a corrected temperature as specified in 52.2.1 or an observed temperature as specified in 52.2.2 exceeds the limit specified in Table 52.1, the test may be repeated at an ambient temperature closer to 25°C.

## 52.3 Temperature measurements

52.3.1 A temperature is considered to be constant when three successive readings taken at intervals of 10 percent of the previously elapsed duration of the test, but not less than 5 minute intervals, indicate no change.

52.3.2 Temperatures are to be measured by thermocouples. However, temperatures of a coil or winding may be determined by the resistance method if the coil is inaccessible for mounting thermocouples – for example, a coil immersed in sealing compound – or if the coil wrap includes thermal insulation, or more than two layers, 1/32 inch (0.8 mm) maximum, of cotton, paper, rayon, or the like.



**Table 52.1**  
**Maximum acceptable temperatures**

\*Table 52.1 revised and separated into Tables 52.1 and 52.2 April 9, 1999\*

Materials and components	°C	(°F)
1. Varnished-cloth insulation	85	185
2. Fuse <sup>a</sup>	90	194
3. Fiber employed as electrical insulation	90	194
4. Wood and other flammable material	90	194
5. Any point on or within a terminal box on a stationary appliance	90	194
6. A surface upon which a stationary appliance may be mounted in service, and surfaces that might be adjacent to the appliance when so mounted	90	194
7. Insulation systems on coil windings of a DC motor, and of a universal motor <sup>b</sup>		
a) Class A insulation systems		
In an open motor:		
Thermocouple method <sup>c</sup>	90	194
Resistance method	100	212
In a totally enclosed motor:		
Thermocouple method <sup>c</sup>	95	203
Resistance method	105	221
b) Class B insulation systems		
In an open motor:		
Thermocouple method <sup>c</sup>	110	230
Resistance method	120	248
In a totally enclosed motor:		
Thermocouple method	115	239
Resistance method	125	257
8. Insulation systems on coil windings of an AC motor (not including universal motor) and on vibrator coils: <sup>b</sup>		
a) Class A insulation systems <sup>b</sup>		
In an open motor and on vibrator coils:		
Thermocouple or resistance method	100	212
In a totally enclosed motor:		
Thermocouple or resistance method	105	221

Table 52.1 Continued on Next Page

Table 52.1 Continued

Materials and components	°C	(°F)
b) Class B insulation systems		
In an open motor and on vibrator coils: <sup>C</sup>		
Thermocouple or resistance method	120	248
In a totally enclosed motor:		
Thermocouple or resistance method	125	257
9. Class 130 insulation systems except as indicated in subitems B in both items 7 and 8		
Thermocouple method	110	230
10. Phenolic composition employed as electrical insulation or as a part the breakdown of which may result in a risk of fire, electric shock or injury to persons <sup>d</sup>		
a) Laminated	125	257
b) Molded	150	302
11. Rubber- or thermoplastic-insulated wire and cord <sup>d,e</sup>	60	140
12. Capacitors <sup>f</sup>		
a) Electrolytic <sup>g</sup>	65	149
b) Other types	90	194
13. A cabinet of thermoplastic material <sup>d</sup>	90	194
14. Class 105 insulation systems on windings of: <sup>d</sup>		
a) A solenoid or a relay		
Thermocouple method <sup>C</sup>	90	194
Resistance method	110	230
b) A transformer		
Thermocouple method <sup>C</sup>	90	194
Resistance method	100	212
15. Copper (bare or insulated) without a nickel coating or other suitable protection	150	302
16. Termination of copper conductor and pressure terminal connectors without a nickel coating or other suitable protection	150	302
17. Lampholder screw shell and center contact	200	392
18. Rectifier: <sup>d</sup>		
a) Selenium	75	167
b) Silicon	100	212
19. At any point within a terminal box or wiring compartment of a permanently connected appliance in which power-supply conductors are to be connected, including such conductors themselves, unless the appliance is marked in accordance with 66.7.1.	60	140

**Table 52.1 Continued**

Materials and components	°C	(°F)
<p><sup>a</sup> A fuse that has been investigated and determined to be acceptable for use at a higher temperature may be used at that temperature.</p> <p><sup>b</sup> These temperatures do not apply to motors with a diameter greater than 7 inches (178 mm). See the note to Table 30.2.</p> <p><sup>c</sup> At a point on the surface of a coil where the temperature is affected by an external source of heat, the temperature measured by means of a thermocouple may be higher by the amount specified in Table 52.2 than the maximum indicated in this table, when the temperature rise of the coil as measured by the resistance method is not more than that specified in this table. See 52.3.1 – 52.3.8.</p> <p><sup>d</sup> These limitations do not apply to compounds or components that have been investigated and determined to be suitable for a higher temperature.</p> <p><sup>e</sup> Rubber-insulated conductors within a Class A insulated motor, rubber-insulated motor leads, and rubber-insulated flexible cord entering a motor may be subjected to a temperature of more than 60°C (140°F), provided that an acceptable braid is employed on the conductor of other than a flexible cord. However, this does not apply to thermoplastic-insulated wires or cords.</p> <p><sup>f</sup> A capacitor that operates at a temperature of more than the value specified in item 12 may be evaluated on the basis of its marked temperature limit.</p> <p><sup>g</sup> For an electrolytic capacitor that is physically integral with or attached to a motor, the temperature on insulating material integral with the capacitor enclosure may not be more than 90°C (194°F).</p>		

**Table 52.2**  
**Additional temperatures**

\*Table 52.1 revised and separated into Tables 52.1 and 52.2 April 9, 1999\*

Item in Table 52.1	°C	(°F)
7 and 14	15	27
8	5	9
Part A of 15	20	36
Part A of 16	10	18

52.3.3 In using the resistance method, the windings are to be at room temperature at the start of the test. The temperature of a winding is to be calculated from the formula:

$$t_2 = \frac{R}{r} (K + t_1) - K$$

*in which:*

*t<sub>2</sub> is the temperature of the coil at the end of the test in degrees C;*

*R is resistance of the coil at the end of the test in ohms;*

*r is resistance of the coil at the beginning of the test in ohms;*

*K is 234.5 for copper, 225.0 for electrical conductor grade (EC) aluminum (values of the constant K for other grades must be determined); and*

*t<sub>1</sub> is room temperature at the beginning of the test in degrees C.*

52.3.4 Thermocouples are to consist of wires not larger than No. 24 AWG (0.21 mm<sup>2</sup>) and not smaller than No. 30 AWG (0.05 mm<sup>2</sup>).

52.3.5 Whenever referee temperature measurements by thermocouples are required, thermocouples consisting of No. 30 AWG (0.05 mm<sup>2</sup>) iron and constant wire and a potentiometer-type instrument are to be used.

52.3.6 The thermocouples and related instruments are to be accurate and calibrated in accordance with good laboratory practice. The thermocouple wire is to comply with the requirements for special thermocouples as listed in the Initial Calibration Tolerances for Thermocouples table in Temperature-Measurement Thermocouples, ANSI/ISA MC96.1.

52.3.7 A thermocouple junction and the adjacent thermocouple lead wire are to be held securely in good thermal contact with the surface of the material of which the temperature is being measured.

52.3.8 For a thermocouple-measured temperature on the coil of a fractional-horsepower, alternating current motor other than a universal motor, the thermocouple is to be applied to the magnet wire, or it is to be separated from that wire by not more than the insulation on the conductor itself. For a thermocouple-measured temperature of a coil of any other motor, the thermocouple is to be mounted as described in the preceding sentence, or it may be separated from the conductor by not more than the insulation on the conductor itself and the normal coil wrap.

#### **52.4 Operation for temperature test**

52.4.1 The temperature test of an appliance intended to be operated with a constant – noncycling – load is to be operated until temperatures become constant. The test is to be repeated with any doors open if the appliance can be operated in this condition, and if ventilation will be affected.

52.4.2 If an appliance is not intended for continuous operation, the temperature test may be conducted to take into consideration the probable intermittent or short-time operation of the appliance. Temperatures are to be monitored so that the maximum temperature rise is recorded for each measurement.

52.4.3 If an appliance incorporates a reel for the power-supply cord, one-third of the length of the cord is to be unreeled for the temperature test.

#### **53 Potential Measurements**

53.1 A potential measurement required to determine whether an appliance complies with the requirements in 24.4.1 and 24.5.1 and Spacings, Section 30, is to be made with the appliance operating under the conditions described in the Input Test, Section 51, with the appliance completely assembled – that is, with all tubes, fuses, connectors, and similar devices, in their proper location. The maximum value obtained is considered to be normal operating potential.

#### **54 Electrolytic Capacitor Test**

54.1 If the maximum voltage across an electrolytic capacitor exceeds its marked voltage rating while the appliance is operated under the conditions described in 55.5.2 and 55.5.4, the capacitor shall not short-circuit when subjected to the test described in 54.2.

54.2 The appliance is to be operated until the capacitor reaches operating temperature after which all tubes are to be removed other than the power rectifier and any other tubes that are necessary to produce maximum direct current voltages. The voltage is then to be measured across the capacitor for 15 minutes. If there is any increase in leakage current or corresponding decrease in voltage, two additional samples are to be tested under the same conditions. The electrolytic capacitor is not acceptable if all three samples do not operate for 15 minutes without short-circuiting.

## 55 Dielectric Voltage-Withstand Test

### 55.1 Primary circuits

55.1.1 An appliance shall withstand, without electrical breakdown for a period of 1 minute, the application of an essentially sinusoidal potential at a frequency within the range of 40 – 70 Hz when tested as described in 55.1.2 – 55.1.6:

- a) Applied successively between each different type of primary circuit and earth ground – dead-metal parts – with all other primary circuits connected to the earth ground.
- b) Applied between any live or current-carrying part of the primary circuit of an isolating-type power transformer and each secondary circuit of that transformer.
- c) Applied between terminals of opposite polarity on capacitors that are connected across-the-line, or from line-to-earth ground – see 55.1.5.

55.1.2 The test potential shall be:

- a) 1000 V for an appliance rated 250 V or less.
- b) 1000 V plus twice rated voltage for an appliance rated more than 250 V.

55.1.3 If an autotransformer is in the circuit, a potential of 1000 V plus twice the rated voltage is to be applied to all wiring involving a potential of more than 250 V. The primary of the autotransformer is to be disconnected and the test potential is to be applied directly to the wiring that involves the higher potentials.

55.1.4 The test potential specified in 55.1.2 and 55.1.3 may be obtained from any convenient source of sufficient capacity – at least 500 V-A unless the meter is located in the output circuit – to maintain the potential indicated in 55.1.2 other than in the case of breakdown. The voltage of the source is to be continuously adjustable.

55.1.5 If the charging current through a capacitor or a capacitor-type filter connected across-the-line, or from line-to-earth ground, is large enough to make it impossible to maintain the required alternating-current test potential, the capacitor and the capacitor-type filter may be tested separately as described in 55.1.6.

55.1.6 A capacitor and a capacitor-type filter as specified in 55.1.5 are to be subjected to a direct-current test potential of 1414 V for equipment rated 250 V or less, or 1414 V plus 2.828 times the rated voltage for equipment rated more than 250 V. The direct current test potential is to be maintained for 1 minute without breakdown.

## 55.2 Limited primary circuits

55.2.1 Uninsulated live parts, as specified in 30.4.1, shall withstand for 1 minute a potential of three times the maximum voltage of the circuit as determined in accordance with 55.5.1 – 55.5.5, or 1270 V, whichever is greater when tested as described in 55.2.2.

55.2.2 The potential is to be started at zero and increased gradually until the required test value is reached or insulation breakdown occurs. Before the test, all lamps, transistors, and tubes are to be removed; the rectifiers are to be short-circuited; electrolytic capacitors are to be removed from the circuit; and bleeder resistors and other power-consuming devices are to be disconnected at the negative side of the circuit.

## 55.3 Secondary and battery circuits

55.3.1 While an appliance is at its maximum operating temperature, a secondary circuit and a battery circuit as defined in 30.7.2, shall withstand for 1 minute without electrical breakdown, a test potential as indicated in Table 55.1 and 55.3.2:

- a) Between parts of opposite polarity in a circuit that is not a safety circuit – see 30.7.1;
- b) Between secondary circuits supplied from separate transformer windings with common connections disconnected; and
- c) Between parts in a circuit and exposed dead-metal parts with all chassis-connected components disconnected at the chassis.

**Table 55.1**  
**Dielectric voltage-withstand test potential for secondary and battery circuits**

Maximum potential in the circuit, volts	Test voltage
1000 or less	Three times maximum voltage in the circuit, but not less than 500 volts
More than 1000	1750 volts plus 1.25 times the maximum voltage in the circuit

55.3.2 The test potential specified in 55.3.1 may be obtained from any convenient source of sufficient capacity – at least 500 V-A unless the meter is located in the output circuit – to maintain the potential indicated in Table 55.1 other than in case of breakdown. The voltage of the source is to be continuously adjustable. A direct-current source is to be used for a direct-current circuit. A 40 – 70 Hz essentially sinusoidal voltage is to be used for testing alternating-current circuits.

## 55.4 Interconnecting cables

55.4.1 An interconnecting cable of an appliance that involves a voltage exceeding 600 V on any conductor of the cable shall withstand for 1 hour the application of a 40 – 70 Hz essentially sinusoidal potential equal to two times the maximum voltage measured on the conductor plus 1000 V when tested as described in 55.4.2 and 55.4.3.

55.4.2 The cable described in 55.4.1 is to be wrapped on a 3/4-inch (19.0-mm) diameter, conductive mandrel. The assembly of cable and mandrel is to be immersed in lead shot for this test.

55.4.3 The test potential is to be applied from the cable conductors to the mandrel and lead shot. Starting at zero, the applied potential is to be increased until the required test value is reached or until breakdown occurs. The increase in the applied potential is to be a substantially uniform rate and as rapidly as consistent with its value being correctly indicated by a voltmeter. The potential is to be held at that level for 1 hour.

## 55.5 Maximum voltage

55.5.1 The maximum voltages used as a basis for the calculation of the dielectric voltage-withstand potentials specified in 55.2.1 and 55.3.1 shall be determined in accordance with 55.5.2 – 55.5.5.

55.5.2 To obtain the maximum voltage, any combination of tubes and fuses are to be removed.

55.5.3 An automatic voltage-regulating device is to be rendered inoperative unless an investigation shows that it can be relied upon to prevent an increase in voltage. Such an investigation is to take into consideration any likely breakdowns in either the regulating device or the appliance, and the possibility of the device being disconnected if it is not permanently connected in the circuit.

55.5.4 A connector or a comparable part that is likely to be disconnected during operation or user-servicing is to be both connected and disconnected during the test.

55.5.5 If a complex voltage is present, the peak value of the voltage is to be measured.

## 56 Abnormal Operation Tests

### 56.1 General

56.1.1 A risk of fire or electric shock shall not result when an appliance is operated under abnormal conditions that are likely to occur during intended use, such as those described in 56.1.2. During the tests described in 56.1.2 – 56.6.1:

- a) The cheesecloth or the tissue paper specified in 56.2.1 shall not glow or flame;
- b) The 3-A fuse specified in 56.2.1 (connected from exposed dead-metal parts to earth ground) shall not open; and
- c) A permanent path shall not result between live parts and exposed metal, as determined by reconducting the electric shock current test specified in the Leakage Current and Shock Current Tests, Section 47.

56.1.2 Malfunction of components and likely misuses of the appliance that could result in a risk of fire or electric shock are to be simulated during the abnormal tests specified in 56.1.1. Examples are:

- a) Misloading, such as too much film or paper at a time, or folded or bunched paper;
- b) Jamming of paper, a slide tray, or film that is likely to stall or overload a drive motor;
- c) Belt breakage of a fan or a blower assembly that ventilates a heater, a projection lamp, or a similar source of high heat;

d) Malfunction of a thermostat, a timer switch, a film or paper-operated switch, except as noted in 56.2.5, that could result in either:

- 1) Continuous energization of a film or heating element or a heat lamp or
  - 2) De-energization of a drive system that removes film or paper from a heater area;
- e) Jamming of film or paper or malfunction of a drive system that could hold paper under a heat source for an excessive length of time;
- f) Stalled rotor of drive motor, fan motor, or similar part;
- g) Blocking the plunger of a solenoid in the de-energized position; and
- h) Operation without fluid or liquid – such as with a processor.

## 56.2 Test conditions

56.2.1 Abnormal operation tests are to be made with the appliance supported in its normal operating position, on a pine board covered with white tissue paper, and with the appliance covered with a single layer of cheesecloth as described in 56.2.2 arranged so that the cloth is close to any openings in the enclosure. A floor-supported commercial appliance with no bottom openings need not be mounted on a pine board with tissue paper; and if there are no openings on the top or sides of the enclosure, a commercial product need not be draped with cheesecloth. Exposed dead-metal parts of the appliance are to be connected to earth ground through a 3-A fuse. The appliance is to be connected to a supply source with a voltage and frequency as specified in Performance, General, Section 45. The supply circuit is to have the maximum-sized overcurrent device that in intended use would be selected for the branch-circuit protection in accordance with the National Electrical Code, ANSI/NFPA 70. Opening of the branch-circuit overcurrent device before any risk of fire or electric shock results is considered to be an acceptable conclusion of a test. Only one abnormal condition is to be simulated at a time.

56.2.2 The cheesecloth specified in 56.2.1 is to be untreated cotton cloth running 14 – 15 square yards per pound (26 – 28 m<sup>2</sup>/kg). Tests involving cheesecloth are to be made in a room free of drafts.

56.2.3 Since a risk of fire or electric shock resulting from the abnormal operation tests usually manifests itself within 1 hour, the tests are ordinarily to be limited to 1 hour. When, at the end of 1 hour, it appears that a risk of fire or electric shock is capable of occurring, the test is to be continued until ultimate results are obtained – usually not more than 7 hours.

56.2.4 A part of an appliance that may be removed during user servicing may be omitted if it is not:

- a) Necessary for the functioning of the appliance;
- b) Exposed to view during normal operation; and
- c) Captivated.

56.2.5 A switch mechanism that has been subjected to a 100,000 cycle endurance test under load is considered to be reliable, and breakdown of such a component is not to be simulated during the abnormal operation tests. The 100,000-cycle endurance test applies to the mechanical parts that actuate the switch as well as the electrical parts.



56.2.6 An appliance with an externally operable voltage selection switch is to be operated with the most adverse voltage settings and branch circuit connection – for example, with the switch set for 120-volt operation and the appliance connected to a 240-volt supply.

56.2.7 An appliance that includes a projection lamp that may be independently switched on and off is to be tested with the lamp energized and de-energized. If a lamp burns out during the test, the test is to be continued without replacing the lamp.

56.2.8 If a component other than a fuse or a circuit breaker open- or short-circuits as a result of an abnormal operation, three complete tests are to be made for that abnormal condition, using a new component for each test.

56.2.9 A fuse that is relied upon during these tests is to be marked in accordance with 67.8.1.

### 56.3 Components

56.3.1 Any two terminals of a rectifier, a vacuum tube, an electrolytic capacitor, or a solid-state device are to be short-circuited.

*Exception: A component located in any one of the following is not required to be short-circuited:*

- a) A secondary circuit as defined by 31.3;*
- b) A limited-energy, primary circuit;*
- c) A low-voltage, limited-energy circuit;*
- d) A circuit that has been investigated for reliability; or*
- e) A circuit that does not involve a risk of fire or electric shock when a short-circuit occurs.*

### 56.4 Limited primary

56.4.1 Each point of the primary circuit nearest the supply circuit that is not capable of delivering a power of 50 watts is to be short-circuited to the circuit return. See 30.4.2.

### 56.5 Transformers

56.5.1 The secondary of a transformer or the output of a power supply that limits the current to 8 A or less as described in 32.2 and 32.6 is to be subjected to continuous operation at applicable overload conditions including short-circuit.

### 56.6 Silver recovery unit

56.6.1 The space between the electrodes of a silver recovery unit is to be short circuited.

## 57 Ozone Test

57.1 An appliance that produces ozone during normal operation shall not produce an average time-weighted concentration above background in excess of 0.1 parts per million, nor a transitory concentration of more than 0.3 parts per million, when tested in accordance with 57.2 and 57.3. The average time-weighted concentration shall be considered as the average concentration over an 8-hour operation period.

57.2 Ozone concentration measurements are to be made at all probable operator positions with the appliance installed in the center of a closed room of approximately 1000 cubic feet (28.3 m<sup>3</sup>) – 8 by 12 by 10 feet high (2.44 by 3.70 by 3.05 m high). The appliance is to be operated in the same manner as for the Temperature Test, Section 52. The test room is to be at normal temperature and relative humidity, and there is to be no circulation of air other than that resulting from appliance operation.

57.3 If operation of the appliance is possible with any of its fans or heaters not functioning or with paper or fluid supplies exhausted, the test described in 57.2 is to be repeated with the various components not operating or without paper or fluid, to determine whether these conditions result in ozone concentrations above that specified in 57.1.

## **58 Strength of Enclosure Test**

### **58.1 General**

58.1.1 The overall enclosure of:

- a) A table model appliance weighing more than 10 pounds (4.5 kg) but not more than 75 pounds (34 kg) or
- b) Any appliance provided with a handle

shall withstand for 1 minute the loading described in 58.1.2 without producing a risk of electric shock and any damage that might result in a risk of fire or injury to persons. See 6.1.8.

58.1.2 The complete appliance is to be set on a 2-inch (51-mm) diameter steel ball resting on a horizontal surface having dimensions not less than those of the base of the appliance. A weight of  $0.25 W + 4$  pounds (1.8 kg) is to be placed on top of the appliance, directly over the steel ball,  $W$  being the weight of the appliance in pounds (kg). Rubber-like and felt materials are to be removed from supporting feet to the extent that they are likely to be worn off in normal service. Supporting feet that are not permanently secured to the enclosure are to be removed.

### **58.2 Wood, glass, and metal enclosures**

58.2.1 The external enclosure of an appliance, if of wood, glass, or metal, shall withstand the two tests described in 58.2.2 and 58.2.3 without:

- a) Permanent distortion to the extent that spacings are reduced below the values specified in Spacings, Section 30;
- b) Transient distortion that results in contact of the enclosure with a live part; and
- c) Development of an opening that exposes an uninsulated live part that involves a risk of fire or electric shock.

Any openings that occur during the tests are to be evaluated under the requirements in 7.1.1 – 7.1.6.

58.2.2 The enclosure is to be subjected to a force of 25 pounds (111 N) for 1 minute. The force is to be applied through a hemisphere 1/2 inch (12.7 mm) in diameter.

58.2.3 After the test described in 58.2.2, the enclosure is to be subjected to an impact of 5 foot-pounds (6.8 J). The impact is to be applied by means of a smooth, solid, steel sphere 2 inches (51 mm) in diameter and weighing approximately 1.18 pounds (535 g). The sphere is to fall freely from rest through a vertical distance of 51 inches (1.30 m).

58.2.3 revised April 9, 1999

## 59 Strain Relief Test

59.1 The strain-relief means for a flexible cord or cable shall withstand a pull of 35 pounds (156 N) for 1 minute applied from any direction to the cord or cable, with the connections within the appliance disconnected. When tested:

- a) The insulation or the covering on the flexible cord or cable shall not be cut or torn;
- b) The bushing shall not be damaged or slide through the hole in the enclosure;
- c) A cemented-on bushing shall not slide on the cord; and
- d) An interlock connector shall not separate from the appliance, nor be damaged so that it does not perform its intended function.

59.2 A fiber bushing shall comply with 59.1 immediately following the humidity conditioning described in 48.2.

59.3 If the integrity of the strain-relief means is dependent upon a polymeric material, the strain-relief test is to be conducted both before and after the enclosure temperature-stability tests.

## 60 Cord and Cable Push-Back Relief Test

60.1 To determine compliance with 10.1.3.1, an appliance shall be tested as described in 60.2. The test shall not result in:

- a) Mechanical damage to the cord;
- b) Exposure of the cord to a temperature higher than that for which it is intended;
- c) Reduction of spacings, such as to a metal strain relief attachment, below the applicable values;  
or
- d) Stress on an internal wiring connection.

60.2 The cord or cable is to be held 1 inch (25 mm) distant from the point where the cord or cable emerges from the appliance. It is to be pushed back with a force until the cord or cable is buckled but in no case shall the force exceed 6 pounds (26.7 N).

## 61 Fluid Entry Test

61.1 An appliance, such as a film processor, shall be subjected to conditions simulating drain stoppage, inadvertent spillage of the solution by the operator, or similar mishap. The overflow or spillage shall not result in a risk of electric shock, as determined by conducting the leakage-current or insulation resistance and dielectric voltage-withstand tests.

61.2 The solution to be used for this test is to consist of 1/2 gram of sodium chloride (NaCl) per liter of water. The overflow or spillage is to simulate actual quantities and rates available in the process.

## MANUFACTURING AND PRODUCTION TESTS

### 62 Dielectric Voltage-Withstand Test

62.1 Each appliance shall withstand without electrical breakdown, as a routine production-line test, the application of an AC potential at a frequency within the range of 40 – 70 Hz or a DC potential between:

- a) The primary wiring, including connected components, and accessible dead-metal parts that are likely to become energized and
- b) Primary wiring and accessible low-voltage – 42.4 V peak or less – metal parts, including terminals when tested as described in 62.2 – 62.10.

62.2 The production-line shall be in accordance with either Condition A, B, C, or D of Table 62.1.

**Table 62.1**  
**Production-line test conditions**

Table 62.1 revised April 9, 1999

Appliance rating	Condition A		Condition B		Condition C		Condition D	
	Potential, volts, AC	Time, seconds	Potential, volts, AC	Time, seconds	Potential, volts, DC	Time, seconds	Potential, volts, DC	Time, seconds
250 volts or less	1000	60	1200	1	1400	60	1700	1
251 volts or greater	1000 + 2V <sup>a</sup>	60	1200 + 2.4V <sup>a</sup>	1	1400 + 2.8V <sup>a</sup>	60	1700 + 3.4V <sup>a</sup>	1

<sup>a</sup> Maximum marked voltage. Refer to Table 45.1.

62.3 The appliance may be in a heated or unheated condition for the test.

62.4 The test shall be conducted when the appliance is complete – that is, fully assembled. It is not intended that the appliance be unwired, modified, or disassembled for the test.

*Exception No. 1: A part, such as a snap cover or a friction-fit knob, that interferes with conducting the test is not required to be in place.*

*Exception No. 2: The test may be conducted before final assembly if the test performed represents that for the completed appliance.*

62.5 An appliance employing a solid-state component that is not relied upon to prevent a risk of electric shock and that can be damaged by the dielectric potential may be tested before the component is electrically connected provided that a random sampling of each day's production is tested at the potential specified in Table 62.1. The circuitry may be rearranged for the purpose of the test to reduce the risk of solid-state component damage while retaining representative dielectric stress of the circuit.

62.6 The test equipment shall include a transformer having an essentially sinusoidal output, a means of indicating the test potential, an audible or visible indicator of electrical breakdown, and either a manually reset device to restore the equipment after electrical breakdown or an automatic reject feature of any unacceptable unit.

62.7 If the output of the test equipment transformer is less than 500 V-A, the equipment shall include a voltmeter in the output circuit to directly indicate the test potential.

62.8 If the output of the test equipment is 500 V-A or more, the test potential may be indicated:

- a) By a voltmeter in the primary circuit or in a transformer tertiary winding circuit;
- b) By a selector switch marked to indicate the test potential; or
- c) In the case of equipment having a single test-potential output, by a marking in a readily visible location to indicate the test potential.

When marking is used without an indicating voltmeter, the equipment shall include a positive means, such as an indicator lamp, to indicate that the manually reset switch has been reset following a dielectric breakdown.

62.9 Test equipment other than that described by 62.6 – 62.8, may be used if it is determined that it accomplishes the intended factory control.

62.10 During the test, the primary switch is to be in the on position, both sides of the primary circuit of the appliance are to be connected together and to one terminal of the test equipment, and the second test equipment terminal is to be connected to accessible dead metal.

*Exception No. 1: An appliance having circuitry – resistive high-impedance winding, or similar circuitry – not subject to excessive secondary-voltage buildup in case of electrical breakdown during the test may be tested with:*

- a) A single-pole primary switch, if used, in the off position or*
- b) Only one side of the primary circuit connected to the test equipment when the primary switch is in the on position or when a primary switch is not used.*

*Exception No. 2: The primary switch is not required to be in the on position if the testing means applies full test potential between primary wiring and dead-metal parts with the switch not in the on position.*

## **63 Electrical Continuity Test**

### **63.1 Grounding continuity**

63.1.1 Each appliance that has a power-supply cord having a grounding conductor shall be tested, as a routine production line test, to determine that grounding continuity exists between the grounding blade of the attachment plug and accessible dead-metal parts of the appliance that are likely to become energized.

63.1.2 A single test is sufficient if the accessible metal selected is conductively connected by design to all other accessible metal.

63.1.3 Any acceptable indicating device, such as an ohmmeter or a battery-and-buzzer combination may be used to determine compliance with the requirement in 63.1.1.

## 63.2 Grounded conductor

63.2.1 Each appliance that is provided with a polarized attachment plug – a 2-wire plug polarized with a wide blade – or is intended to be permanently connected to the power supply, shall be subjected to a routine electrical continuity test conducted between the grounded supply-circuit conductor of the attachment plug, lead, or terminal and the part of the appliance that is intended to be connected to the grounded supply-circuit conductor. If the continuity cannot be readily determined by visual inspection and component checking, an electrical continuity test is to be made.

## RATING

### 64 Electrical Rating

64.1 An appliance shall be rated in volts. An appliance that is intended for use with alternating current shall be provided with the rated frequency expressed in one of the following terms: hertz, Hz, cycles per seconds, cps, cycles/second, or c/s. An appliance that is intended for use with direct current shall be rated "direct current" or "DC," and shall have an input rating in amperes if the full-load power factor is less than 80 percent, or in amperes or watts if the full-load power factor is 80 percent or more.

64.2 A general purpose receptacle that is provided as a part of an appliance but that is not intended for the connection of a part of the appliance shall be rated in accordance with 64.1.

64.3 If an appliance includes an attachment-plug receptacle that is not intended as a disconnecting means for any part of the appliance or necessary accessory, and that may serve as a general-use outlet, the added load that the receptacle may impose on the appliance and its supply connections – that is, the rated load of the receptacle in accordance with 64.2 – shall be taken into consideration in determining the electrical rating of the appliance.

## MARKING

### 65 General

65.1 Unless specifically stated otherwise, a required marking shall be permanent, clear, legible, and readily visible.

65.2 A marking that is required to be permanent shall be located on a part that requires the use of a tool for removal or on a part that cannot be removed without impairing the operation of the appliance.

65.3 A marking that is required to be permanent shall be molded, die-stamped, paint-stenciled, stamped or etched metal that is permanently secured, or indelibly stamped lettering on pressure-sensitive labels secured by adhesive that complies with the Standard for Marking and Labeling Systems, UL 969. Ordinary usage, handling, or storage of the appliance shall be considered in the determination of the permanence of the marking.

### 66 Informational

#### 66.1 Identification and rating

66.1.1 An appliance shall be legibly and permanently marked with:

- a) The manufacturer's name, trade name, or trademark or other descriptive marking by which the organization responsible for the product may be identified;
- b) A distinctive (catalog or model) number or the equivalent;

- c) The electrical rating; and
- d) The date or other dating period of manufacture not exceeding any three consecutive months.

*Exception No. 1: The manufacturer's identification may be in a traceable code if the appliance is identified by the brand or trademark owned by a private labeler.*

*Exception No. 2: The date of manufacture may be abbreviated; or may be in a nationally accepted conventional code or in a code affirmed by the manufacturer, if the code does not:*

- a) Repeat in less than 10 years and*
- b) Require reference to the production records of the manufacturer to determine when the appliance was manufactured.*

66.1.2 If an appliance contains a single motor as its only electrical load, the electrical rating given on the motor nameplate need not be shown elsewhere on the appliance provided this nameplate is clearly and legibly visible after the motor has been installed in the appliance, and the rating complies with 64.1.

66.1.3 If the complete appliance consists of two or more separate units, the marking specified in 66.1.1 shall appear on the basic unit; and the input rating shall be equal to the sum of the individual inputs. Each other unit shall be individually marked with the manufacturer's name, trade name, or trademark; the date or other dating period of manufacture not exceeding any three consecutive months; and a distinctive catalog number or the equivalent.

*Exception: If it is not possible to indicate the sum of the individual ratings at a single point, the individual units shall be marked with their electrical rating and the basic unit may be marked to refer to the sum of the ratings of the individual units as finally assembled.*

66.1.4 A receptacle as specified in 64.2 shall have its electrical rating marked on or near the receptacle. If the receptacle supplies alternating current or direct current only, the marking shall so indicate.

## **66.2 Alternate supply voltages**

66.2.1 An appliance that is constructed so that alternate voltages can be obtained by means of an externally operable switch or by field alteration of internal connections shall be marked to indicate the voltages for which the different settings are intended.

## **66.3 Multiple factory**

66.3.1 If a manufacturer produces or assembles the same appliance at more than one factory, each finished appliance shall have a distinctive marking – which may be in code, if desired – by means of which it can be identified as the product of a particular factory.

## **66.4 Lamp replacement**

66.4.1 An appliance employing a projection lamp shall be marked "Replace with same type (DAK) or 500 watt, 120-V lamp," or equivalent wording, where it is readily visible during lamp replacement.

## 66.5 Other than general-purpose receptacle

66.5.1 A receptacle or connector of other than the general-purpose type, with or without a jumpered plug, that is:

- a) Intended for the connection of an adapter or an accessory;
- b) In itself involves energy in excess of that defined in 32.1 – 32.9, or the use of which may produce a risk of fire or electric shock;
- c) Readily perceptible by the user; and
- d) Not used for the connection of a part of the appliance

shall be marked to indicate either the specific acceptable accessory or adapter, or the acceptable use for which it is intended.

66.5.2 With reference to the requirement in 66.5.1, a receptacle or connector is considered to be readily perceptible by the user if it is recognizable during the intended procedure of operation or user servicing, visually or by casual touch, or if the appliance or the literature packed with the appliance is marked to indicate the presence of the receptacle or connector. When a bonding means is provided that is not assembled to the appliance, the appliance is marked to indicate the presence of the bonding means.

## 66.6 On-off switch

66.6.1 There shall be a plainly marked off position or "1" for "On" and "0" for "Off" on or adjacent to a switch of other than a momentary-contact type if the switch controls parts that might involve a risk of injury to persons during use. The symbols  $\bigcirc$  and  $\text{I}$  (IEC publication 417, symbol Nos. 5008 and 5007) may be used for this purpose. Identification shall not be by illumination alone.

66.6.1 revised April 9, 1999

## 66.7 Wiring compartment

66.7.1 If any point within a wiring compartment of a permanently connected appliance in which the power-supply conductors are intended to be connected, including such conductors themselves, reaches a temperature of more 60°C (140°F) during the temperature test, the appliance shall be marked "For supply connection, use wires suitable for at least \_\_\_\_°C (\_\_\_\_°F)," or with an equivalent statement, and the temperature value marked in the indicated space shall be in accordance with Table 66.1. This statement shall be located at or near the point where supply connections are intended to be made, and shall be clearly visible both during and after installation of the appliance.

**Table 66.1**  
**Wiring compartment marking**

Temperature reached in wiring compartment during temperature test,		Required marking,	
°C	(°F)	°C	(°F)
61 – 75	142 – 167	75	167
76 – 90	169 – 194	90	194



## 66.8 Use of circuit breaker or time-delay fuses

66.8.1 An appliance as described in 50.1 that will not start and operate normally when connected to a circuit protected by a fuse of other than the time-delay type, but that will start and operate normally when connected to a circuit protected by a time-delay fuse, shall be marked with the following or the equivalent: "Connect to a supply circuit protected by a circuit breaker or time-delay fuse."

## 66.9 Projector for professional use

66.9.1 A projector as described in 44.1 shall be marked "FOR PROFESSIONAL USE ONLY" or the equivalent.

## 66.10 Component replacement

66.10.1 The location and type designation of a user-serviceable component, such as a tube, a lamp (other than projection type), or a battery, shall be marked on the appliance where the marking is readily visible during servicing of the component, unless replacement of the component by a different type does not increase the risk of fire, electric shock, or injury to persons.

## 66.11 Supply circuit and overcurrent protective device

66.11.1 An appliance consisting of motors and other loads shall be marked in accordance with one of the following where readily visible during power supply connections:

- a) "Minimum branch circuit conductor ampacity for connection \_\_\_\_ A. Maximum branch circuit overcurrent protective device rating to be provided \_\_\_\_ A."

Note: Minimum ampacity for connection is determined by counting all of the motors and other loads that will be operated at the same time and computing as follows: Full Load Amps (FLA) for all motors plus 25 percent of highest rated motor in the group plus the current rating of the remaining circuits.

The short-circuit and ground-fault protective device rating shall not exceed 20 A for 120 V rated units or 15 A for higher (V) rated units (refer to Section 430-53 of the National Electrical Code, ANSI/NFPA 70).

- b) "Largest motor \_\_\_\_ V, \_\_\_\_ A."

Added 66.11.1 effective April 9, 2000

## 67 Cautionary

### 67.1 General

67.1.1 A marking intended to caution the operator shall be legible and visible to the operator during the normal operation of the appliance. Servicing instruction markings shall be legible and visible when such servicing is being performed.

67.1.2 A cautionary marking shall be prefixed by the word CAUTION, WARNING, OR DANGER in letters not less than 1/8 inch (3.2 mm) high, the remaining letters of such marking shall not less than 1/16 inch (1.6 mm) high.

67.1.3 An appliance having more than one supply circuit shall be marked with the word "CAUTION," and the following or the equivalent: "Risk of electric shock, connected to more than one supply circuit. Disconnect all circuits before servicing."

## 67.2 Ultraviolet lamp

67.2.1 A compartment without an interlock that houses an ultraviolet lamp shall be marked with the word "WARNING," and the following or equivalent: "Eye damage may result from direct viewing of the ultraviolet lamp used in this unit. Always turn off lamp before opening this cover." The marking shall be readily visible during any approach to entering the compartment.

## 67.3 High-pressure lamp

67.3.1 A compartment that houses a xenon or other high-pressure lamp as defined in 23.1 shall be marked with the word "DANGER," and the following or equivalent: "High-pressure lamp involves a risk of explosion. Handle in accordance with manufacturer's use or installation instructions, and refer servicing to qualified service personnel." The marking shall be readily visible during any approach to entering the compartment.

## 67.4 Capacitor discharge

67.4.1 A warning to the service person that a removable panel covering a capacitor shall not be removed for whatever time – 5 minutes maximum – is required for the capacitor to discharge to the values specified in 24.4.1 after the appliance has been disconnected from its source of power shall be marked on or near the panel with the word "WARNING," and the following or equivalent: "Risk of electric shock. Serviceman – charged capacitor behind this panel – wait \_\_\_\_ minutes after disconnecting appliance from power supply before removing panel."

## 67.5 Battery

67.5.1 A battery-powered appliance that has provision for the recharging of user-serviceable rechargeable batteries shall be marked, where readily visible to the user when changing batteries, to:

- a) Specify the type and size of batteries to be used and
- b) Caution the user against use of other types of batteries that may explode causing personal injury and damage to the appliance.

The marking shall include the word "CAUTION," and the following or equivalent: "Risk of explosion – use only type \_\_\_\_ rechargeable batteries."

## 67.6 Hot surface

67.6.1 An appliance having an enclosure surface that exceeds the temperature limits specified in item 2 or 3 of Table 42.1 – see 42.3 and 42.4 – shall be marked with the word "CAUTION," and the following or equivalent: "HOT."

## 67.7 Servicing

67.7.1 A compartment in a household appliance involving a risk of electric shock, housing no user-serviceable parts and no plug-in-type hidden tube or vibrator, shall be marked where readily visible during any approach to servicing with the word "CAUTION," and the following or equivalent: "Risk of electric shock, do not remove cover (or back). No user-serviceable parts inside. Refer servicing to qualified service personnel."

## 67.8 Fuse replacement

67.8.1 A fuse replacement marking, located where readily visible during replacement of the fuse, shall be provided adjacent to a fuse or fuseholder if the fuse is used to meet the requirements of this standard. The marking shall consist of the word "CAUTION," and the following or equivalent: "For continued protection against risk of fire replace only with same Type \_\_\_\_ A- \_\_\_\_ V fuse." If the fuse is soldered in place and is perceptible during user servicing, the marking shall, in addition to the above, include the following equivalent wording: "Refer replacement to qualified service personnel."

*Exception: If the available space does not permit locating the fuse replacement marking adjacent to the fuse or fuseholder or if the appliance employs more than one fuse or fuseholder requiring marking, the marking except for the rating may be at some other location where readily visible during replacement of the fuse.*

## 67.9 Bonding

67.9.1 If bonding is not provided with the appliance, the appliance shall be marked where readily visible during installation (such as inside of the cover) with the word "CAUTION" and either of the following or the equivalent:

- a) "Bonding between conduit connections is not automatic and must be provided as a part of the installation."
- b) "Nonmetallic enclosure does not provide grounding between conduit connections. Use grounding type bushings and jumper wires."

## 67.10 Flammable film

67.10.1 A commercial motion picture projector not provided with fire rollers or enclosed film magazines shall be marked, where the marking will be visible during installation of the film reel, with the word "WARNING," and the following or equivalent: "To avoid risk of fire, do not use nitrate or other flammable film. Use safety film only."

## 67.11 Ungrounded dead-metal parts

67.11.1 The following marking shall be provided on or adjacent to the ungrounded dead-metal parts mentioned in 13.1.9: "WARNING" and the following or equivalent wording. "(Identify part or parts not earth grounded) present risk of electric shock. Test before touching." The marking shall be visible so that each part or group of parts are positively identified.

## 67.12 Stability

67.12.1 An appliance requiring a stabilizing means as described in 38.5 shall be marked with the word "CAUTION" and the following or equivalent: "To reduce risk of injury to persons due to unstable unit, actuate stabilizer before (drawer, gate, and the like) is extended." The marking shall be located where it will be readily visible to service personnel.

## 67.13 Lasers

67.13.1 The service manual of an appliance containing a laser component shall comply with the requirements of the Code of Federal Regulations, 21 CFR 1040.

Added 67.13.1 effective April 9, 2000

67.13.2 The operation manual of an appliance containing a laser component shall comply with the requirements of the Code of Federal Regulations, 21 CFR 1040.

Added 67.13.2 effective April 9, 2000

67.13.3 A compartment without an interlock that contains a laser component shall comply with the requirements of the Code of Federal Regulations, 21 CFR 1040.

Added 67.13.3 effective April 9, 2000

67.13.4 With reference to 67.13.1 – 67.13.3, compliance of laser products with the Code of Federal Regulations (CFR), Title 21, Part 1040, shall be determined by:

- a) Determining the Class of laser (as defined by the CFR) from the manufacturers required documentation, such as the Center for Devices and Radiological Health (CDRH) report, markings and labels, or similar documentation;
- b) Verifying that the manufacturer's markings and labels, having the information specified in the CFR, are affixed on the laser product (as defined in the CFR);
- c) Determining that the corresponding construction features, such as protective housing, interlocks, and similar features, are provided in accordance with the CFR; and
- d) Determining that the resulting construction complies with the construction requirements of this standard.

67.13.4 added July 11, 2001

## INSTRUCTIONS

### 68 General

68.1 An instruction manual or the equivalent shall be provided with an appliance.

68.2 An installation diagram or instructions or both shall accompany an appliance if there may be any question regarding the connections or method of operation.

68.3 A cord-connected appliance that is constructed so that alternate voltages can be obtained by means of an externally operable switch, or by field alternation of internal connections, shall be provided with instructions that indicate:

- a) The proper voltage position for the particular attachment plug furnished with the appliances when shipped from the factory;
- b) How to adjust the input voltage selector; and
- c) How to use an adapter or attachment plug when the input voltage selector is changed.

If the supply cord is a grounding type, the color coding of the leads shall be specified when referencing instructions for changing the attachment plug.

68.4 The installation instructions, operating manuals, and advertising literature supplied with or in conjunction with an appliance shall not recommend any procedure that might result in a risk of fire, electric shock, or injury to persons.

## **69 Safety Instructions**

69.1 The instruction manual for household equipment shall have safety instructions that specifically warn the user against reasonably foreseeable risks of injury and state the precautions that should be taken to guard against those risks.

69.2 The safety instructions shall be a permanent part of the instruction manual but separated in format from the other instructions, and shall appear before the operating instructions in the instruction manual.

69.3 The letters in the text and illustrations in the safety instructions shall be not less than 1/12 inch (2.1 mm) high for upper case letters and 1/16 inch (1.6 mm) high for lower case letters. "IMPORTANT SAFETY INSTRUCTIONS" and "SAVE THESE INSTRUCTIONS" shall be in letters not less than 3/16 inch (4.8 mm) high.

69.4 The text of the instructions in 69.5 shall be verbatim or in equally definitive terminology.

*Exception No. 1: If an item is inappropriate or not applicable to the appliance, it may be omitted. See 69.6.*

No Text on This Page

*Exception No. 2: Other safeguard items considered appropriate for the appliance may be inserted.*

*Exception No. 3: The list of items may be numbered or unnumbered.*

69.5 The words "IMPORTANT SAFETY INSTRUCTIONS" shall precede the list of items below. The words "SAVE THESE INSTRUCTIONS" shall follow the list. The words "Read and Understand all instructions before using" shall be the first item in the list:

### IMPORTANT SAFETY INSTRUCTIONS

When using your photographic equipment, basic safety precautions should always be followed, including the following:

1. Read and understand all instructions before using.
2. Close supervision is necessary when any appliance is used by or near children. Do not leave appliance unattended while in use.
3. Care must be taken as burns can occur from touching hot parts.
4. The appliance switch is provided with the symbols 0 indicating off and 1 indicating on. The symbols **O** and **I** may be used for this purpose.
5. Do not operate appliance with a damaged cord or if the appliance has been dropped or damaged – until it has been examined by a qualified serviceman.
6. Position the cord so that it will not be tripped over, pulled, or contact hot surfaces.
7. If an extension cord is necessary, a cord with a current rating at least equal to that of the appliance should be used. Cords rated for less amperage than the appliance may overheat.
8. Always unplug appliance from electrical outlet before cleaning and servicing and when not in use. Never yank cord to pull plug from outlet. Grasp plug and pull to disconnect.
9. Let appliance cool completely before putting away. Loop cord loosely around appliance when storing.
10. To reduce the risk of electric shock, do not immerse this appliance in water or other liquids.
11. To reduce the risk of electric shock, do not disassemble this appliance, but take it to a qualified serviceman when service or repair work is required. Incorrect reassembly can cause electric shock when the appliance is used subsequently.
12. The use of an accessory attachment not recommended by the manufacturer may cause a risk of fire, electric shock, or injury to persons.
13. Connect this appliance to a grounded outlet.
14. Disconnect this unit from its source of supply before replacing the projection lamp.

15. This appliance has a polarized plug (one blade is wider than the other). To reduce the risk of electric shock, this plug is intended to fit in a polarized outlet only one way. If the plug does not fit fully in the outlet, reverse the plug. If it still does not fit, contact a qualified electrician. Do not modify the plug in any way.

### SAVE THESE INSTRUCTIONS

Revised 69.5 effective April 9, 2000

69.6 The instructions for an appliance that is battery-operated only are not required to include text items in 69.5 that are specifically related to cord-connected appliances.

## ACCESSORY EQUIPMENT

### 70 General

70.1 In addition to the provisions in Sections 1 – 70, the requirements in 70.2 – 73.5 are applicable to accessory equipment.

70.2 For the purpose of these requirements, accessory equipment is defined as equipment intended to be attached or added to an appliance, and of such size that they may be marked for identification by a catalog number or its equivalent. Accessory equipment usually is dependent upon the basic appliance for mechanical support, electrical support, input, or a combination of these, and may or may not perform a complete function by itself.

70.3 The term accessory equipment is not intended to cover individual items of circuitry or components that, for reasons of improving, modifying, or repairing the functions of an appliance, are added to the appliance subsequent to the time of initial assembly, and that lose their identity in the process.

### 71 Construction

71.1 Accessory equipment shall be constructed so that it can be added to an appliance without creating a risk of fire, electric shock, or injury to persons.

71.2 The installation of accessory equipment by an operator shall be restricted to an arrangement that can be accomplished mechanically by means of simple tools and electrically by means of plug-in connections to receptacles available on the appliance or as a part of the building wiring.

71.3 The installation of accessory equipment by qualified service personnel shall be such that:

- a) The mechanical positioning can be accomplished by means of regular tools available at an appliance installation or by means of special tools provided by the manufacturer as a part of the installation kit and
- b) The electrical connections can be readily accomplished by making use, wherever possible, of existing terminals and connections in the appliance.

71.4 The requirement in 71.3 does not preclude the addition, removal, or rerouting of insulated conductors to accomplish the desired change if the alterations in the appliance wiring:

- a) Can be accomplished by the use of materials and reference to instructions, both of which are furnished as part of the accessory-equipment kit and



- b) Do not require the use of a makeshift or substitute part not normally used in the basic constructions of the appliance.

71.5 All wiring as a part of an item of accessory equipment or related to its installation shall be acceptable for use at the highest voltage and temperature that can be encountered in the area in which the wiring is intended to be installed.

## 72 Performance

### 72.1 General

72.1.1 The mechanical mounting arrangements and types of plugs provided with operator-installed accessory equipment shall be such that:

- a) The accessory equipment can be properly positioned and
- b) The plug-in connections cannot be inadvertently interchanged in a manner that introduces a risk of fire or electric shock.

### 72.2 Installation and operation

72.2.1 To determine whether accessory equipment complies with the requirement in 72.1.1, each piece of accessory equipment is to be installed in its intended manner on the appliance for which it is intended by following the instructions provided. See 73.3 and 73.4.

72.2.2 With the item of accessory equipment installed and operating, the basic appliance is to be subjected to each of the tests described in Sections 1 – 71 that are considered necessary in determining that the performance of the appliance is not altered in an unacceptable manner.

## 73 Marking

73.1 Each item of accessory equipment shall be marked with the manufacturer's name, trade name, or trademark; the date or other dating period of manufacture not exceeding any three consecutive months; and a distinctive catalog number or the equivalent.

*Exception No. 1: The manufacturer's identification may be in a traceable code if the appliance is identified by the brand or trademark owned by a private labeler.*

*Exception No. 2: The date of manufacture may be abbreviated, in a nationally accepted conventional code, or in a code affirmed by the manufacturer.*

73.2 The repetition time cycle of a date code shall not be less than 10 years. The date code shall not require reference to the manufacturer's production records to determine when the appliance was manufactured.

73.3 Accessory equipment that is supplied with power from a separate branch circuit shall be marked with an input rating and related information as stated in Sections 1 – 71.

73.4 Accessory equipment intended to be installed by an operator shall be marked to indicate the appliance for which it is intended and shall include instructions on the equipment that will provide sufficient information to enable the accessory equipment to be properly mounted on and interconnected with the basic appliance.

73.5 Accessory equipment intended to be installed by qualified personnel shall include instructions, either on or packed with each item of accessory equipment, that will provide a step-by-step outline of the mechanical and electrical alterations that may be performed to provide proper installation and operation.

## SUPPLEMENT SA - HIGH-PRESSURE LAMPS AND LAMP SYSTEMS

### SA1 Scope

SA1.1 These requirements cover all high-pressure lamps and lamp systems. These systems may include a high-pressure lamp, a protective cover for the lamp, and the lamphouse in which the lamp is installed to operate.

Added SA1.1 effective April 9, 2000

SA1.2 These requirements are specifically intended for equipment designed for motion-picture projection applications including video-projectors, scenic projectors, theatrical follow-spots, virtual reality games, and the like.

Added SA1.2 effective April 9, 2000

SA1.3 A high-pressure lamp system shall comply with the applicable requirements of this standard, modified by the requirements contained in this supplement.

Added SA1.3 effective April 9, 2000

### SA2 Glossary

SA2.1 For the purposes of this supplement the following definitions apply.

Added SA2.1 effective April 9, 2000

SA2.2 APERTURE – The opening or window through which usable light is emitted from the assembly.

Added SA2.2 effective April 9, 2000

SA2.3 DOWSER – The mechanical device used to control the amount of light emitted from the aperture of the lamphouse.

Added SA2.3 effective April 9, 2000

SA2.4 LAMP – The light-source assembly, consisting of the electrodes, the gas, and the quartz containing the pressurized system.

Added SA2.4 effective April 9, 2000

SA2.5 LAMPHOUSE – An enclosure housing a high-pressure lamp and all associated apparatus that is separate from a lighting fixture, picture projector, or the like.

Added SA2.5 effective April 9, 2000

SA2.6 LIGHTING FIXTURE – An assembled lighting unit other than a picture projector, a lamphouse, or a special-purpose lamp enclosure.

Added SA2.6 effective April 9, 2000

SA2.7 PROTECTIVE COVER – The removable cover for the lamp that is intended to be left in place until the lamp is put into a lamphouse, and that is intended to reduce the likelihood of glass or metal parts escaping if the lamp breaks.

Added SA2.7 effective April 9, 2000

SA2.8 SERVICE MANUAL – The manual that contains complete operation, maintenance, and repair instructions for the assembly. This includes normal lamp replacement and check-out procedures in the event of a lamp explosion. This manual is intended only for use by qualified personnel.

Added SA2.8 effective April 9, 2000

SA2.9 SHIPPING CONTAINER – A container for both the lamp and its protective cover.

Added SA2.9 effective April 9, 2000

SA2.10 SNOOD – A cylindrical band constructed of metal that surrounds the aperture of the lamphouse.

Added SA2.10 effective April 9, 2000

### SA3 General

SA3.1 A high-pressure lamp system shall comply with the requirements contained in this Standard, as well as the Standard for Motor-Operated Appliances, UL 73.

Added SA3.1 effective April 9, 2000

### SA4 Enclosure

SA4.1 A lamphouse shall be constructed in such a manner that access to the lamp compartment can be gained only through an interlocked enclosure panel.

Added SA4.1 effective April 9, 2000

SA4.2 A lamphouse enclosure panel intended for access to the lamp shall be constructed so that removal of the panel can only be accomplished by two distinct movements. One of these movements shall involve the use of a key-lock with a removable key. A second fastening means that would have to be separately and distinctly unfastened to permit final access to the lamp compartment shall also be provided. The construction shall be such that both fasteners must be secured before the lamp will operate in the intended manner.

Added SA4.2 effective April 9, 2000

SA4.3 Except as noted in SA4.4, a high-pressure lamp system that produces ozone during normal operation shall not produce an average time-weighted concentration above background in excess of 0.1 parts per million when tested in accordance with the Ozone Test, Section SA14. The average concentration is considered to be over an eight hour period.

Added SA4.3 effective April 9, 2000

SA4.4 The requirement stated in SA4.3 does not apply if the high-pressure lamp system is provided with a suitable means for venting ozone to the outside atmosphere.

Added SA4.4 effective April 9, 2000

SA4.5 The enclosure of a high-pressure lamp system shall be constructed so that light generated by the lamp will emit only from the intended aperture.

Added SA4.5 effective April 9, 2000

SA4.6 The enclosure of a high-pressure lamp system shall be constructed so that glass or metal fragments resulting from a hot-lamp explosion will be totally contained by the enclosure.

Added SA4.6 effective April 9, 2000

## SA5 Internal Construction

SA5.1 A high-pressure lamp system igniter circuit shall be investigated in accordance with the Standard for Television Receivers and High-Voltage Video Products, UL 1410, or the Standard for Audio-Video Products and Accessories, UL 1492.

Added SA5.1 effective April 9, 2000

SA5.2 A lamp shall be provided with a protective cover to contain any glass or metal fragments if the lamp breaks.

Added SA5.2 effective April 9, 2000

SA5.3 To determine compliance with SA5.2, a protective cover containing a lamp shall be subjected to the tests specified in SA11.3.

Added SA5.3 effective April 9, 2000

## SA6 General

SA6.1 A high-pressure lamp system shall be subjected to the applicable tests specified in Sections SA7–SA13. The tests shall be conducted in the order given whenever practicable.

Added SA6.1 effective April 9, 2000

## SA7 Power Input Test

SA7.1 The power input to a high-pressure lamp system shall not be less than 90 percent nor more than 105 percent of its marked rating.

Added SA7.1 effective April 9, 2000

SA7.2 The power input is to be measured with the system at normal operating temperature under full-load conditions and while connected to a supply circuit adjusted to the maximum value of the marked input voltage rating.

Added SA7.2 effective April 9, 2000

## SA8 Normal Temperature Test

SA8.1 A high-pressure lamp system, when tested in accordance with SA8.2, shall comply with the following:

- a) At any point, the system shall not attain a temperature sufficiently high enough to increase the risk of fire or to damage any material employed in the system and
- b) Temperature rises at specific points shall not be greater than those indicated in Table SA8.1.

Added SA8.1 effective April 9, 2000

SA8.2 For tests that are to be continued until constant temperatures are attained, thermal equilibrium is considered to exist only when three successive readings indicate no change. The readings are to be taken at the conclusion of each of three consecutive equal time intervals. The duration of the intervals shall be ten percent of the total test time elapsed prior to the start of the first interval or five minutes, whichever is greater.

Added SA8.2 effective April 9, 2000

**Table SA8.1**  
**Maximum temperature rises**

Added Table SA8.1 effective April 9, 2000

Parts	°C	(°F)
External enclosure except handles, and knobs held in normal use:		
Metallic	50	90
Nonmetallic	55	99
Handles, knobs, and grips that in normal use are continuously held:		
Metallic	30	54
Porcelain or vitreous material	40	72
Molded material, rubber, or wood	50	90
Handles, knobs, and grips that in normal use are held for short periods (i.e. switches and focusing knobs):		
Metallic	35	63
Porcelain or vitreous material	45	81
Molded material, rubber, or wood	55	99
NOTE – All values of temperature rise are based on an assumed ambient (room) temperature of 25°C (77°F).		

### SA9 Dielectric Voltage-Withstand Test

SA9.1 A high-pressure lamp system shall be capable of withstanding for one minute without breakdown a 60 Hz, essentially sinusoidal potential applied between live metal parts and dead-metal parts, with the appliance at its maximum normal operating temperature. The test potential (in V rms) shall be as indicated below:

- a) 1000 volts between live and dead-metal parts and
- b) 1.25 times "V" plus 1750 volts at 400 Hz between primary and secondary windings of an igniter transformer. (See SA9.3 for the value of "V".)

Added SA9.1 effective April 9, 2000

SA9.2 To determine compliance with SA9.1, an appliance shall be tested by means of a 500 V-A or larger capacity transformer, the output voltage of which is essentially sinusoidal and can be varied. The applied potential is to be increased gradually from zero until the required test value is reached, and then held at that value for one minute. The increase in the applied potential is to be at a substantially uniform rate and as rapid as is consistent with its value being correctly indicated by the voltmeter.

Added SA9.2 effective April 9, 2000

SA9.3 The value of "V" in SA9.1(b) is determined by measuring the open-circuit secondary voltage of the igniter transformer during the operation of the high-pressure lamp system by means of an oscilloscope or other measuring instrument determined to be acceptable.

Added SA9.3 effective April 9, 2000

### **SA10 Abnormal Operation Test**

SA10.1 A high-pressure lamp system with a lamp installed as intended shall contain all glass or metal fragments as a result of breakage of the lamp during hot lamp explosion.

Added SA10.1 effective April 9, 2000

SA10.2 To determine compliance with SA10.1, the tests described in SA10.3 and SA10.4 are to be conducted.

Added SA10.2 effective April 9, 2000

SA10.3 A high-pressure lamp system is to be operated with the exhaust fan (if provided) operating. The dowser is to be closed and all reflecting mirrors are to be in place. When operating temperatures have stabilized, the dowser is to be opened and the lamp broken by means of a steel rod placed against the lamp and struck on the opposite end by a rubber mallet.

Added SA10.3 effective April 9, 2000

SA10.4 A high-pressure lamp system is to be operated with the exhaust fan (if provided) inoperative, the dowser closed, and all reflecting mirrors removed. When operating temperatures have stabilized, the lamp intensity is to be increased to maximum, and the lamp is to be broken by striking a steel rod as described in SA10.3.

Added SA10.4 effective April 9, 2000

SA10.5 The tests described in SA10.3 and SA10.4 are to be conducted with the high-pressure lamp system installed in a solid wooden box constructed to the dimensions of the system with 12 inch (305 mm) sides. All interior surfaces of this box, including the bottom, are to be lined with heavy, white industrial paper. The steel rod mentioned in SA10.3 is to be inserted through the outer enclosure and positioned with one end against the lamp, which is then to be broken as described in SA10.3.

Added SA10.5 effective April 9, 2000

SA10.6 A high-pressure lamp system and lamp shall not increase the risk of explosion when operated with the protective cover in place on the lamp.

Added SA10.6 effective April 9, 2000

### **SA11 Nonmetallic Enclosure Test**

SA11.1 A high-pressure lamp system enclosure, constructed of polymeric material, shall comply with the Standard for Polymeric Materials – Use in Electrical Equipment Evaluations, UL 746C.

Added SA11.1 effective April 9, 2000

SA11.2 A high-pressure lamp system enclosure part constructed of polymeric material that is not relied on for protection against the effects of lamp explosion shall be investigated in accordance with SA11.1. Otherwise, enclosure parts shall be investigated in accordance with SA10.1.

Added SA11.2 effective April 9, 2000

SA11.3 A protective cover containing a lamp shall show no holes, cracks, distortion, or other conditions that would not comply with the constructional requirements, after being tested in accordance with Oven Conditioning, Section SA12, and the Resistance to Impact Test, Section SA13.

Added SA11.3 effective April 9, 2000

## SA12 Oven Conditioning

SA12.1 A protective cover containing a lamp shall be placed in an air-circulating oven in accordance with one of the following methods, the method used being at the choice of the manufacturer:

- a)  $100 \pm 1^{\circ}\text{C}$  ( $212 \pm 2^{\circ}\text{F}$ ) for a period of 7 days;
- b)  $90 \pm 1^{\circ}\text{C}$  ( $194 \pm 2^{\circ}\text{F}$ ) for a period of 14 days;
- c)  $80 \pm 1^{\circ}\text{C}$  ( $176 \pm 2^{\circ}\text{F}$ ) for a period of 28 days; or
- d)  $70 \pm 1^{\circ}\text{C}$  ( $158 \pm 2^{\circ}\text{F}$ ) for a period of 112 days.

Added SA12.1 effective April 9, 2000

SA12.2 A protective cover containing a lamp shall be placed in an air-circulating oven maintained at  $90 \pm 1^{\circ}\text{C}$  ( $194 \pm 2^{\circ}\text{F}$ ) for a period of seven hours.

Added SA12.2 effective April 9, 2000

## SA13 Resistance to Impact Test

SA13.1 A protective cover containing a lamp of the recommended size shall withstand the impact described in SA13.2 on both "as received" representative units and a unit conditioned in accordance with SA12.1.

Added SA13.1 effective April 9, 2000

SA13.2 To determine compliance with SA13.1, the lamp and protective cover are to be suspended horizontally on a wire support inside a plywood chamber 8 feet (2.44 m) long by 4 feet (1.22 m) square with 1/2 inch (12.7 mm) thick walls. The wire is released, allowing the lamp and protective cover to fall from a height of 3 feet (0.9 m) onto a concrete floor. The test is to be repeated with the lamp and protective cover suspended in the vertical position.

Added SA13.2 effective April 9, 2000

SA13.3 A protective cover containing a lamp shall withstand three impacts of 5 ft-lb (0.6915 kg-m) each on both "as received" and conditioned representative units (conditioned in accordance with SA12.2).

Added SA13.3 effective April 9, 2000

SA13.4 The impact force applied to a part of an enclosure is obtained from a solid, smooth, steel sphere 2 inches (50.8 mm) in diameter and weighing approximately 1.18 lbs (535 g). This sphere is allowed to fall freely from rest through the distance required to cause it to strike the top of the enclosure with the specified impact. For surfaces other than the top of the enclosure, the sphere is to be suspended by a suitable cord and allowed to fall as a pendulum through the distance required to strike the surface with the specified impact. The enclosure is placed so that the surface tested is vertical and in the same vertical plane as the point of support of the pendulum. Parts of the enclosure that may interfere with the cord of the pendulum are to be removed.

Added SA13.4 effective April 9, 2000

SA13.5 A protective cover containing a lamp shall withstand the impact test specified in SA13.6. This test is to be conducted on an "as received" representative unit.

Added SA13.5 effective April 9, 2000



SA13.6 To determine compliance with SA13.5, the protective cover containing a lamp is to be placed in an environmental chamber adjusted to a uniform temperature of 0°F (minus 17.8°C) for a period of twenty-four hours. The protective cover containing a lamp is then to be removed from the chamber and immediately tested by dropping from a height of 3 feet (0.9 m) onto a concrete floor.

Added SA13.6 effective April 9, 2000

#### **SA14 Ozone Test**

SA14.1 Ozone concentration measurements are to be made at all probable operator positions with the high-pressure lamp system installed in the center of a closed room of approximately 1000 cubic feet (28 m<sup>3</sup>). A room 8 by 12 by 10 feet (2 by 4 by 3 m) is suitable for this. The system is to be operated in the same manner as for the Temperature Test, Section 52. The test room is to be at normal temperature and relative humidity, and there is to be no circulation of air other than that resulting from normal machine operation.

Added SA14.1 effective April 9, 2000

SA14.2 If operation of the machine is possible with any of its fans not functioning, the test described in SA14.1 is to be repeated a sufficient number of times with the various fans inoperative to determine that this condition does not result in ozone concentrations above the levels specified in SA4.3. See the Ozone Test, Section 57.

Added SA14.2 effective April 9, 2000

#### **SA15 Hot Restrike Test**

SA15.1 Immediately following the Temperature Test, Section 52, while the lamp is still hot, the lamp is to be turned off and turned on. This sequence is to be repeated three times. The lamp shall not explode.

Added SA15.1 effective April 9, 2000

#### **SA16 General**

SA16.1 The high-pressure lamp system shall be marked where readily visible with the following markings (as applicable):

- a) The word "WARNING" and the following or equivalent, "Risk of explosion. Service and maintenance should be performed only by qualified personnel as determined by the high-pressure lamp system manufacturer. Protective clothing and procedures as outlined in the manufacturer's service manual should be followed.";
- b) The word "WARNING" and the following or equivalent, "Risk of eye injury. Do not attempt to view into the aperture with the lamp system in operation.";
- c) The word "WARNING" and the following or equivalent, "Risk of injury from generation of ozone. A means of venting must be provided.";
- d) The word "CAUTION" and the following or equivalent, "Risk of burn injury. Do not come in close proximity to the area in front of the snood.";
- e) The word "CAUTION" and the following or equivalent, "Risk of fire or explosion. Use only a high-pressure lamp of the recommended size and type in this lamp system."; and

f) The word "CAUTION" and the following or equivalent, "Risk of electric shock. Use only a high-pressure lamp system power supply of the recommended type with this lamp system".

Added SA16.1 effective April 9, 2000

SA16.2 The shipping container shall be marked with the word "WARNING" and the following or equivalent statement, "Risk of explosion. Do not remove."

Added SA16.2 effective April 9, 2000

## APPENDIX A

### Standards for Components

Standards under which components of the products covered by this standard are evaluated include the following:

Title of Standard – UL Standard Designation

---

Air Filter Units – UL 900  
Armored Cable – UL 4  
Attachment Plugs and Receptacles – UL 498  
Capacitors – UL 810  
Cathode-Ray Tubes – UL 1418  
Circuit Breakers, Molded-Case, Molded-Case Switches, and Circuit-Breaker Enclosures – UL 489  
Class 2 Power Units – UL 1310  
Components, High-Voltage, for Television-Type Appliances – UL 1413  
Controls, Limit – UL 353  
Cord Sets and Power-Supply Cords – UL 817  
Double Insulation Systems for Use in Electrical Equipment – UL 1097  
Electric Heating Appliances – UL 499  
Enclosures for Electrical Equipment – UL 50  
Filters, Electromagnetic Interference – UL 1283  
Fittings for Cable and Conduit – UL 514B  
Flexible Cord and Fixture Wire – UL 62  
Fuseholders – UL 512  
Fuses, Class H – UL 198B  
Fuses, Class R – UL 198E  
Fuses, Class T – UL 198H  
Fuses for Supplementary Overcurrent Protection – UL 198G  
Fuses, Plug – UL 198F  
Ground-Fault Circuit Interrupters – UL 943  
Industrial Control Equipment – UL 508  
Lampholders, Edison-Base – UL 496  
Marking and Labeling Systems – UL 969  
Motor-Operated Appliances – UL 73  
Motors, Overheating Protection for – UL 2111  
Outlet Boxes, Metallic – UL 514A  
Plastic Materials for Parts in Devices and Appliances, Tests for Flammability of – UL 94  
Polymeric Materials – Fabricated Parts – UL 746D  
Polymeric Materials – Long Term Property Evaluations – UL 746B  
Polymeric Materials – Short Term Property Evaluations – UL 746A  
Polymeric Materials – Use in Electrical Equipment Evaluations – UL 746C  
Power Units Other Than Class 2 – UL 1012  
Printed-Wiring Boards – UL 796  
Protectors, Supplementary, for Use in Electrical Equipment – UL 1077  
Sharpness of Edges on Equipment, Test for – UL 1439  
Switches, Clock-Operated – UL 917  
Switches, Special-Use – UL 1054  
Systems of Insulating Materials – General – UL 1446

---

Tape, Polyvinyl Chloride, Polyethylene, and Rubber Insulating – UL 510  
Temperature-Indicating and -Regulating Equipment – UL 873  
Terminal Blocks – UL 1059  
Terminals, Electrical Quick-Connect – UL 310  
Thermal Cutoffs for Use in Electrical Appliances and Components – UL 1020  
Thermistor-Type Devices – UL 1434  
Transformers, Class 2 and Class 3 – UL 1585  
Transformers, Specialty – UL 506  
Tubing, Extruded Insulating – UL 224  
Wire Connectors and Soldering Lugs for Use with Copper Conductors – UL 486A  
Wire Connectors for Use with Aluminum Conductors – UL 486B  
Wires and Cables, Thermoplastic-Insulated – UL 83  
Wires and Cables, Thermoset-Insulated – UL 44

## CANADIAN REQUIREMENTS COMPARISON GUIDE CRG 122

---

### UL AND CANADIAN STANDARDS FOR PHOTOGRAPHIC EQUIPMENT

Product Category: Photographic Equipment  
UL Category Control Number: QINT7

UL Standard:

Standard for Photographic Equipment  
UL 122  
Fourth Edition

Canadian Standard:

Safety of Information Technology Equipment  
CAN/CSA C22.2 No. 950-95  
Third Edition (Bi-National with UL 1950 Third Edition)

This Canadian Requirement Comparison Guide is only intended to identify Canadian requirements that must be applied in addition to the requirements in the UL Standard to obtain a C-UL Mark. The guide is not intended to replace a thorough review and comparison of the requirements applicable to the product category as contained in the applicable UL and Canadian Standards. Where requirements are not specifically addressed, compliance with the requirements in the UL Standard satisfy the requirements in the Canadian Standard.

The actual requirements applied for a C-UL product investigation may differ from those identified in this guide based on the specific features, characteristics, components, materials, or systems used in the product.

CRG: 122

Issue No.: 1

Issue Date: March 14, 1997

Revisions of this guide will be made by issuing revised or additional pages bearing their date of issue. A Canadian Requirement Comparison Guide is current only if it incorporates the most recently adopted revisions, all of which are itemized on the transmittal notice that accompanies the latest set of revision pages for the Guide.

Copyright © 1997, 1999 Underwriters Laboratories Inc.

Additional Definitions:

Protection Against Electric Shock – Equipment is classified as one of the following:

Class I equipment (grounded) – Equipment provided with a means for protective earth;

Class II equipment – Equipment provided with double or reinforced insulation (not grounded);

Class III equipment (SELV) accessible – Equipment SELV supplied, no hazardous voltages generated.

Hazardous Voltage – Voltage which exceeds 42.4 V peak (30 rms) or 60 Vdc, not a limited current circuit.

Extra Low Voltage (ELV) – Voltage which does not exceed Hazardous Voltage values and exists in a secondary circuit, separated from hazardous voltage by at least basic insulation.

Safety Extra Low Voltage (SELV) – Voltage between two accessible live secondary parts (i.e. RS232), or between accessible live parts and protective earth, that does not exceed ELV levels under normal and single fault conditions.

Limited Current Circuit – For circuits 1 kHz or less, steady state current is less than 0.7 mA peak AC or 2 mA dc. For circuits above 1 kHz the limit is 0.7 mA multiplied by the frequency (kHz), but not more than 70 mA peak.

Operational Insulation – Insulation which does not protect against electric shock but may minimize ignition and fire.

Basic Insulation – Insulation which provides basic protection against electric shock.

Supplementary Insulation – Insulation which is applied in addition to basic insulation.

Double Insulation – Insulation comprised of both basic and supplementary insulation.

Reinforced Insulation – A single insulation system equivalent to double insulation.

Creepage Distance – The shortest path measured along the surface.

Clearance Distance – The shortest distance measured through air.

The following outlines the requirements contained in CSA C22.2 No. 950-95 that are in addition to the requirements in UL 122 that must be met in order for a product to bear the appropriate UL Marking. UL provides a certification program for products that meet the Canadian requirements. The C-UL Mark is the manufacturers assurance that products, as evaluated by UL, continue to comply with the appropriate Canadian requirements.

<u>Topics</u>	<u>CSA Clause</u>	<u>Comparison</u>
<b>CONSTRUCTION</b>		
General Requirements	1.3.3	Equipment is classified according to its protection from electric shock as Class I, Class II, or Class III.
Components	1.5	Components shall comply with the relevant CSA Standard. Some specific components are mentioned.
	1.5.2	Thermal Controls shall comply with CSA C22.2 No. 24 and CSA C22.2 No. 209.
	1.5.3	A safety isolating transformer shall be constructed so that a single insulation fault will not cause a hazardous voltage to appear on SELV windings.
	1.5.4	High Voltage components operating at greater than 4000 V p-p shall have a flammability class equal to or better than V-2 or HF-2.
Marking and Instructions	1.7	Unit shall be marked with rated amperes (additional wattage rating may be provided).
	1.7.1	Where symbols are used, they shall conform with ISO 7000 and IEC 417.
	1.7 – 1.7.17	All warnings and caution markings and instructions related to safety may be in French and English, at the manufacturer's discretion. Products intended for use in Canada shall have cautionary markings in both English and French.
	1.7.2	For units that may produce ozone, the instructions shall refer to the need to take precautions to ensure that ozone concentration is limited to a safe value.
	1.7.7	Wiring terminals intended for connection of protective earth conductors for supply wiring shall have IEC 417, No. 5019 symbols.
	1.7.12	A marking is required for units whose leakage current exceeds 3.5 mA.
	1.7.17	A warning marking is required for lithium batteries.
Insulation	2.2.6	Categories of Insulation – see examples of application of insulation, Table 0.1.
Primary Power Isolation	2.6.2	The disconnect device shall have a contact separation of at least 3 mm.



## Table Continued

<u>Topics</u>	<u>CSA Clause</u>	<u>Comparison</u>
Overcurrent and Earth Fault Protection in Primary Circuits	2.7	The minimum number of fuses or circuit breaker poles required for primary circuitry are outlined in Tables 1 and 2.
Warning to Service Personnel	2.7	Warning to service personnel is required. See clause 2.7.6.
Safety Interlocks	2.8.4	Safety interlock is considered to comply with a 10,000 cycle endurance rating. Reed type switches in ELV circuits are required to cycle 100,000 times.
	2.8.5	The safety Interlock override system for service personnel shall not bypass a safety interlock for an extreme hazard unless another reliable means of safety protection becomes effective when the interlock is bypassed.
Clearances, Creepage Distances, and Distances through Insulation	2.9	Depending on the degree of insulation systems used, the creepage and clearance distances are shown in Tables 3, 4, 5 and 6. The distance through insulation is shown in subclause 2.9.4.1. Spacings for field wiring terminals are shown in Table 3.
Limited Power Source	2.11	The protection of conductors of external interconnecting cords and cables connected to secondary circuit shall have either:
		a) overcurrent protection in accordance with the Canadian Electrical Code, Part 1;
		b) refer to Table 8; or
		c) refer to Table 9.
Wiring Connection and Supply	3.1	Wiring shall comply with CSA C22.2 No. 127 or UL Recognized Component, Appliance Wiring Material.
	3.1.1	The protection of primary circuit internal wiring and conductors of external interconnecting cords and cables shall be in accordance with the Canadian Electrical Code, Part 1, with exceptions. (Refer to Annex NAE of CSA C22.2 No. 950-95).
	3.1.12	Allows use of SP-3 type cord for table-top products and use of TS type cord for hand-held products.
Power-Supply Cords	3.2.3, 3.2.4	Appliance inlet shall comply with CSA C22.2 No. 182.3.
		General use receptacles, attachment plugs, and similar wiring devices shall comply with CSA C22.2 No. 42.

### Table Continued

<u>Topics</u>	<u>CSA Clause</u>	<u>Comparison</u>
Power-Supply Cords		Power-supply cords shall comply with CSA C22.2 No. 21.
	3.2.4	Same as 3.1.12.
	3.2.5	Methods such as tying the cord into a knot or tying the cord with a string are not acceptable.
Wiring Terminals for External Primary Power Supply Conductors	3.3	Field Wiring Terminals shall comply with CSA C22.2 No. 158.
	3.3.5	Terminals shall have minimum sizes as shown in Table 14.
	3.3.9	Terminals shall be so located, guarded, or insulated that, should a strand of a flexible conductor escape when the conductor is fitted, there is no risk of accidental contact between such a strand and: <ul style="list-style-type: none"> <li>a) accessible conductive parts or</li> <li>b) unearthed conductive parts separated from accessible conductive parts by supplementary insulation only.</li> </ul>
Stability and Mechanical Hazards	4.1.5	A high pressure lamp, defined as pressure exceeding 0.2 MPa (29 psi) when cold or 0.4 MPa (58 psi) while operating, shall have an adequate mechanical enclosure to reduce the risk of injury.
Mechanical Strength of Cathode Ray Tubes	4.2.8	Cathode Ray Tubes with more than 160 mm face dimension shall comply with CSA C22.2 No. 228.
Accessibility of Live Parts	4.3.9	Equipment shall be so constructed that, should any wire, screw, nut, washer, spring or similar part become loose or fall out of position, it cannot in normal use become so disposed that creepage distances or clearances over supplementary insulation or reinforced insulation are reduced to less than the values specified in 2.9.
	4.3.12	Equipment that can generate ionizing radiation or ultraviolet light, or that uses a laser, or in which flammable liquids, flammable gases or similar hazards are present, shall be so designed that harmful effects to persons and damage to materials affecting safety are prevented. Except for equipment using lasers or generating ionizing radiation, compliance is checked by inspection.

### Table Continued

<u>Topics</u>	<u>CSA Clause</u>	<u>Comparison</u>
Accessibility of Live Parts		For ionizing radiation compliance is checked by the test in annex H.
		For equipment using lasers, compliance is checked according to Annex NAE.
	4.3	Openings shall either not exceed 5 mm in any dimension, not exceed 1 mm in width, and for openings over live parts, be constructed to prevent an object from entering the unit, as shown in Figure 8, and for openings in the sides, be provided with louvers as shown in Figures 9 and 10. See clauses 4.3.14 – 4.3.16.
		Protection of heating elements is required in class 1 equipment. See clause 4.3.20.
Flammability of Materials and Components	4.3.21	Equipment employing lithium cells or batteries with similar hazards shall be designed to prevent reverse polarity charging of the battery and to prevent forced charge or forced discharge if this would result in a hazard. See clause 4.3.21.
	4.3.22	If a barrier or screen provided to comply with 4.3.14, 4.3.15, 4.3.16, or 4.4.6 is secured with adhesive to the inside of the enclosure or to other parts inside the enclosure, the adhesive shall have adequate aging properties. See 4.3.22 for details.
	4.4.3.2	Except as specified in 4.4.3.3, all materials and components shall have appropriate flame ratings. See clause 4.4.3.2.
Materials for Enclosures and for Decorative Parts	4.4.3.6	Air filter assemblies shall be constructed of materials of flammability class V-2, or better, or of HF-2, or better, except those indicated in clauses 4.4.3.6.
	4.4.4	For movable equipment, having a total mass not exceeding 18 kg, fire enclosures are considered to comply without test if, in the smallest thickness used, the material is of flammability class V-1 or better. Alternatively, such fire enclosures are permitted if they pass the test of clause A.2.
Fire Enclosure Construction	4.4.6	Equipment intended for use in a restricted access location and to be mounted on a concrete floor or other noncombustible surface need not be provided with a bottom enclosure if marked "Suitable for mounting on concrete or other noncombustible surface only."

## Table Continued

<u>Topics</u>	<u>CSA Clause</u>	<u>Comparison</u>
Flammable Liquids	4.4.8	The maximum quantity of flammable liquid stored in a unit is 5 liters. See clause 4.4.8.
Connection to Telecommunication Networks	6.1 – 6.6	For equipment that is intended to connect to telecommunication networks see entire clause 6.
PERFORMANCE		
General Conditions for Test	1.4.5	The supply voltages used for a test are the most unfavorable of the following variables: <ul style="list-style-type: none"> <li>a) multiple rated voltages</li> <li>b) extremes of rated voltage ranges</li> <li>c) tolerance on rated voltage as specified by the manufacturer. If no tolerance then: for products rated up to 230 V single phase or 400 V three phase the tolerance is plus 6 and minus 10 percent. For products rated over 230 V single phase or 400 V three phase, the tolerance is <math>\pm 10</math> percent.</li> </ul>
Durability of Markings	1.7.15	The marking is rubbed for 15 seconds with water soaked cloth and again for 15 seconds with cloth soaked in petroleum spirit.
Protection Against Electric Shock and Energy Hazards	2.1.5	Measurements are made in operator access areas to determine that there are no stored energy levels greater than 20 J, or power levels greater than 240 VA at a potential of 2 V or more. See clauses 2.1.5 – 2.1.10 for testing requirements.
Humidity Conditioning	2.2.3	Applies to all units, performed with a relative humidity of 91 percent to 95 percent, at a temperature of 20°C to 30°C, followed by a Dielectric Withstand Test.
Safety Interlocks	2.8.2	Safety interlocks shall automatically initiate disconnection of the supply to hazardous voltage parts, reduce within 2 seconds the voltage to 42.4 V peak or 60 Vdc or less, and the energy level to less than 20 J.
Clearances, Creepage Distances and Distances Through Insulation	2.9.1	Using the unjointed test finger, a 10 N force is applied on internal covers/barriers for 5 seconds, then a 30 N force is applied to external enclosures or guards for 5 seconds.
Connection to Other Equipment	2.10.1	Interconnection circuits shall be selected to provide continued conformance with the requirements of 2.3 for SELV circuits, and with the requirements of clause 6 for TNV circuits after making connections between equipments.

### Table Continued

<u>Topics</u>	<u>CSA Clause</u>	<u>Comparison</u>
Limited Power Source	2.11	See Tables 8 and 9.
Connection to Primary Power	3.2.5	Supply (or interconnecting) cords are subjected 25 times, for 1 second, to a pull of the value shown in Table 12 (value is a function of unit weight), cord cannot be displaced by more than 2 mm and shall withstand a dielectric test between the power cord conductors and accessible conductive parts, at a test voltage appropriate for reinforced insulation.
Cord Guard Test	3.2.7	With the axis of the cord-guard projected at a 45 degree angle, a mass equal to 10 times the square of the cord diameter is attached to the cord, then the radius of the curvature of the cord is measured.
Wiring Terminals for External Primary Power Supply Conductors	3.3	Refer to 3.3.2 and 3.3.9 for tests relating to affixing of connectors and exposed wiring at terminals, respectively.
Stability and Mechanical Hazards	4.1.1	Floor standing units are also subjected to an 800 N downward force applied at the point of maximum momentum to any horizontal surface.
Mechanical Strength and Stress Relief	4.2.2	Using the straight unjointed test finger of Figure 19, a 30 N force is applied to operator access areas for 5 seconds.
Metal Enclosures	4.2.3	Using a test tool with a circular contact surface of 30 mm diameter, a 250 N force is applied to external metal enclosures for 5 seconds.
Fluid Entry Test	4.3.4	Using the liquid specified by the manufacturer, the container is overfilled by 15 percent of capacity, followed by a dielectric test.
Strength of Handles Test	4.3.5	An axial force of 15, 20, 30, or 50 N, depending on unit characteristics, is applied for 1 minute to the handles. See clause 4.3.5 for specifics.
Heating	5.1	Performed at the most unfavorable supply voltages (see clause 1.4.5), usually plus 6 percent and minus 10 percent of the unit rating. Limits for Temperatures are shown in Table 16.
Earth Leakage Current	5.2.2	Leakage current values vary for different types of equipment. Refer to Table 17. Test method uses isolating type transformer, see Figures 13 and 14.
	5.2.3	For all single and three phase units, cord and permanently connected, with EMI filter bypassed, the maximum allowable leakage current is shown in Table 17.

**Table Continued**

<b><u>Topics</u></b>	<b><u>CSA Clause</u></b>	<b><u>Comparison</u></b>
Electrical Strength	5.3	Depending on the degree of insulation the test values are shown in Table 18.
Abnormal Operating and Fault Conditions	5.4	Equipment shall be so designed that the risk of fire or electric shock due to mechanical or electrical overload or failure, or due to abnormal operation or careless use, is limited as far as practicable. See clauses 5.4.1 – 5.4.10.
Telecommunications	6.1 – 6.6	For equipment intended to be connected to telecommunication networks see entire clause 6.

**Superseded requirements for  
the Standard for  
Photographic Equipment  
UL 122, Fourth Edition**

The requirements shown are the current requirements that have been superseded by requirements in this edition. The numbers in parentheses refer to the new requirements with future effective dates that have superseded these requirements. To retain the current requirements, do not discard the following requirements until the future effective dates are reached.

15.1.3 (13.1.3) The means for grounding shall be:

- a) A knockout or equivalent opening in the metal enclosure of an appliance intended to be permanently connected by a metal-enclosed wiring system;
- b) An appliance grounding terminal or lead of an appliance intended to be permanently connected by a nonmetallic-enclosed wiring system – for example, nonmetallic-sheathed cable; or
- c) An equipment-grounding conductor in the cord of a cord-connected appliance.

15.1.9 (13.1.9) Discrete conductors used for bonding shall equal or exceed the size of the wiring to components mounted on or near the dead metal parts likely to become energized.

45.2.1 (47.2.1) During intended operation, the leakage current at any accessible part shall not be more than 0.5 mA when tested in accordance with 45.2.2 – 45.2.5 if the open-circuit potential between the accessible part and earth ground or any other accessible part is more than

- a) 42.4 V peak for an indoor appliance or where wet contact is not likely to occur and
- b) 21.2 V peak for an outdoor appliance or where wet contact is likely to occur.

*Exception: A commercial appliance that is required to have primary-circuit filtering to comply with EMC regulations of the country in which it is intended to be used may have leakage current to accessible parts of more than 0.5 mA provided the leakage current does not exceed 5.0 mA and the appliance is provided with grounding that complies with Section 15.*

45.2.2 (47.2.2) The measurement circuit for leakage current is to be as illustrated in Figure 45.1. The measurement instrument is defined in items a – c. The meter that is actually used for a measurement need only indicate the same numerical value for a particular measurement as would the defined instruments; it need not have all the attributes of the defined instrument.

- a) The meter is to have an input impedance of 1500 ohms resistive shunted by a capacitance of 0.15 microfarad.
- b) The meter is to indicate 1.11 times the average of the full-wave rectified composite waveform of voltage across the resistor or current through the resistor.

c) Over a frequency range of 0 – 100 kHz, the measurement circuitry is to have a frequency response – ratio of indicated to actual value of current – that is equal to the ratio of the impedance of a 1500 ohm resistor shunted by 0.15 microfarad capacitor to 1500 ohms. At an indication of 0.5 or 0.75 mA, the measurement is to have an error of not more than 5 percent of 60 Hz.

45.2.3 (47.2.3) Unless the meter is being used to measure leakage current from one part of an appliance to another, it is to be connected between the accessible parts and the grounded-supply conductor.

45.2.4 (47.2.4) A sample of the appliance is to be tested for leakage current starting with the as-received condition – the as-received condition being without prior energization, except as may occur as part of the production-line testing – with all switches closed, but with its grounding conductor, if any, open at the attachment plug. The supply voltage is to be as specified in Table 43.1. The test sequence, with reference to the measuring circuit – Figure 45.1 – is to be as follows:

a) With switch S1 open, the appliance is to be connected to the measuring circuit. Leakage current is to be measured using both positions of switch S2, and with the appliance switching devices in all of their normal operating positions.

b) Switch S1 is then to be closed energizing the appliance, and within 5 seconds, the leakage current is to be measured using both positions of switch S2, and with the appliance switching devices in all of their normal operating positions, except operator-adjusted thermostats are to be adjusted to their maximum heat settings.

c) Leakage current is to be monitored until thermal stabilization. Both positions of switch S2 are to be used in determining this measurement. Thermal stabilization is to be obtained by operation as in the normal temperature test. If any operator-adjusted thermostat does not cycle at the maximum heat setting, it is to be adjusted until it does cycle before the final measurements at thermal stabilization are taken. Measurements are to be made with the thermostat, if any, open and closed.

d) If the appliance employs a single pole switch, monitoring of leakage current is to continue until the leakage current stabilizes or decreases after the appliance is turned off.

45.2.5 (47.2.5) Normally a sample will be subjected to the complete leakage current test, as specified in 45.2.4, without interruption for other tests. With the concurrence of those concerned, the leakage current test may be interrupted to conduct other nondestructive tests.



**Figure 45.1 (47.1)**  
**Leakage-current measurement circuits**

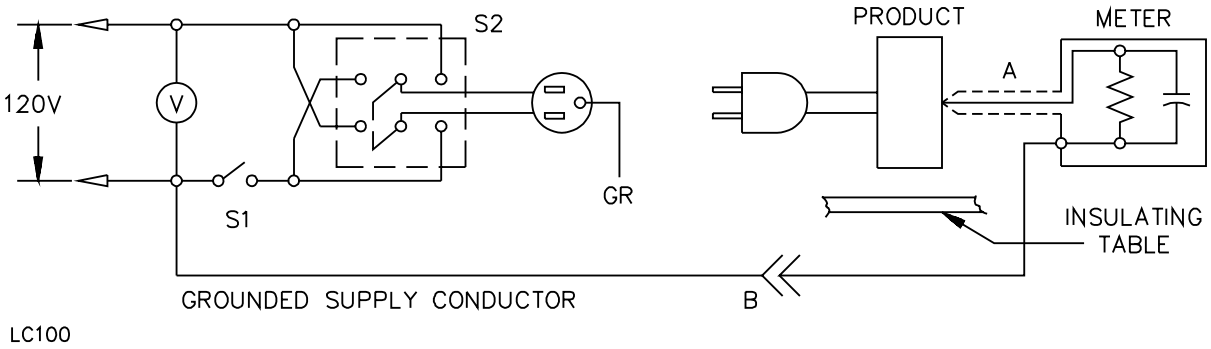

Appliance intended for connection to a 3-wire, grounded-neutral power supply, as illustrated above.

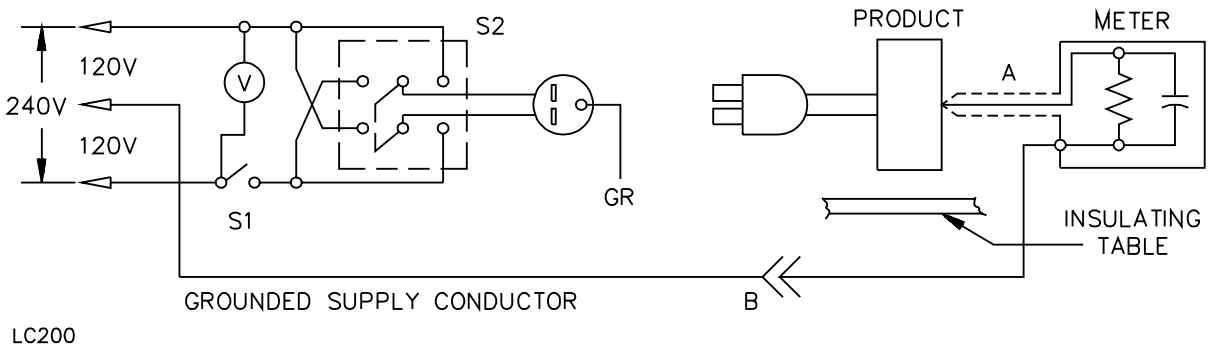

Appliance intended for connection to a 3-wire, grounded-neutral power supply, as illustrated above.

46.2 (48.2) To determine whether a product complies with the requirement in paragraph 46.1, a sample

**Figure 45.1 (47.1) (Cont.)**

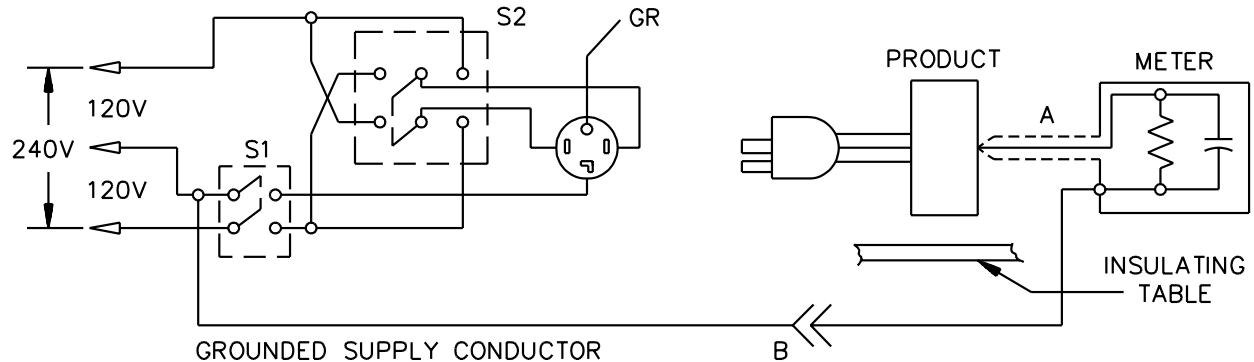

LC300

Appliance intended for connection to a 120 volt power supply.

- a) Probe with a shielded lead.
- b) Separated and used as clip when measuring currents from one part of an appliance to another.

of the product is to be heated to a temperature just above 34°C (93°F) to reduce the likelihood of condensation of moisture during conditioning. The heated sample is to be placed in the humidity chamber and is to remain for 48 hours at a relative humidity of  $88 \pm 2$  percent at a temperature of  $32 \pm 2$ °C ( $90 \pm 4$ °F). Following the conditioning, the sample is to be tested unenergized as described in item a of 45.2.4. The sample is then to be energized and tested as described in items b and c of 45.2.4. The test is to be discontinued when the leakage current stabilizes or decreases.

67.5 (69.5) The word "IMPORTANT SAFETY INSTRUCTIONS" shall precede the list of items below. The words "SAVE THESE INSTRUCTIONS" shall follow the list. The words "Read and Understand all instructions before using" shall be the first item in the list:

#### IMPORTANT SAFETY INSTRUCTIONS

When using your photographic equipment, basic safety precautions should always be followed, including the following:

1. Read and understand all instructions before using.
2. Close supervision is necessary when any appliance is used by or near children. Do not leave appliance unattended while in use.
3. Care must be taken as burns can occur from touching hot parts.
4. Do not operate appliance with a damaged cord or if the appliance has been dropped or damaged – until it has been examined by a qualified serviceman.

5. Position the cord so that it will not be tripped over, pulled, or contact hot surfaces.
6. If an extension cord is necessary, a cord with a current rating at least equal to that of the appliance should be used. Cords rated for less amperage than the appliance may overheat.
7. Always unplug appliance from electrical outlet before cleaning and servicing and when not in use. Never yank cord to pull plug from outlet. Grasp plug and pull to disconnect.
8. Let appliance cool completely before putting away. Loop cord loosely around appliance when storing.
9. To reduce the risk of electric shock, do not immerse this appliance in water or other liquids.
10. To reduce the risk of electric shock, do not disassemble this appliance, but take it to a qualified serviceman when service or repair work is required. Incorrect reassembly can cause electric shock when the appliance is used subsequently.
11. The use of an accessory attachment not recommended by the manufacturer may cause a risk of fire, electric shock, or injury to persons.
12. Connect this appliance to a grounded outlet.
13. Disconnect this unit from its source of supply before replacing the projection lamp.

SAVE THESE INSTRUCTIONS

No Text on This Page