

UL 1083

ISBN 1-55989-890-9

# Household Electric Skillets and Frying-Type Appliances



Underwriters Laboratories Inc. (UL)  
333 Pfingsten Road  
Northbrook, IL 60062-2096

UL Standard for Safety for Household Electric Skillets and Frying-Type Appliances, UL 1083

Fourth Edition, Dated July 28, 1995

Revisions: This Standard contains revisions through and including October 19, 2001.

Text that has been changed in any manner is marked with a vertical line in the margin. Changes in requirements are marked with a vertical line in the margin and are followed by an effective date note indicating the date of publication or the date on which the changed requirement becomes effective.

The new and revised requirements are substantially in accordance with UL's Bulletin(s) on this subject dated March 14, 2001 and June 6, 2001.

The revisions dated October 19, 2001 include a reprinted title page (page1) for this Standard.

As indicated on the title page (page 1), this UL Standard for Safety is an American National Standard. Attention is directed to the note on the title page of this Standard outlining the procedures to be followed to retain the approved text of this ANSI/UL Standard.

The master for this Standard at UL's Northbrook Office is the official document insofar as it relates to a UL service and the compliance of a product with respect to the requirements for that product and service, or if there are questions regarding the accuracy of this Standard.

UL's Standards for Safety are copyrighted by UL. Neither a printed copy of a Standard, nor the distribution diskette for a Standard-on-Diskette and the file for the Standard on the distribution diskette should be altered in any way. All of UL's Standards and all copyrights, ownerships, and rights regarding those Standards shall remain the sole and exclusive property of UL.

All rights reserved. No part of this publication may be reproduced, stored in a retrieval system, or transmitted in any form by any means, electronic, mechanical photocopying, recording, or otherwise without prior permission of UL.

Revisions of UL Standards for Safety are issued from time to time. A UL Standard for Safety is current only if it incorporates the most recently adopted revisions.

UL provides this Standard "as is" without warranty of any kind, either expressed or implied, including but not limited to, the implied warranties of merchantability or fitness for any purpose.

In no event will UL be liable for any special, incidental, consequential, indirect or similar damages, including loss of profits, lost savings, loss of data, or any other damages arising out of the use of or the inability to use this Standard, even if UL or an authorized UL representative has been advised of the possibility of such damage. In no event shall UL's liability for any damage ever exceed the price paid for this Standard, regardless of the form of the claim.

UL will attempt to answer support requests concerning electronic versions of its Standards. However, this support service is offered on a reasonable efforts basis only, and UL may not be able to resolve every support request. UL supports the electronic versions of its Standards only if they are used under the conditions and operating systems for which it is intended. UL's support policies may change from time-to-time without notification.

UL reserves the right to change the format, presentation, file types and formats, delivery methods and formats, and the like of both its printed and electronic Standards without prior notice.

Purchasers of the electronic versions of UL's Standards for Safety agree to defend, indemnify, and hold UL harmless from and against any loss, expense, liability, damage, claim, or judgement (including reasonable attorney's fees) resulting from any error or deviation introduced while purchaser is storing an electronic Standard on the purchaser's computer system.

If a single-user version electronic Standard was purchased, one copy of this Standard may be stored on the hard disk of a single personal computer, or on a single LAN file-server or the permanent storage device of a multiple-user computer in such a manner that this Standard may only be accessed by one user at a time and for which there is no possibility of multiple concurrent access.

If a multiple-user version electronic Standard was purchased, one copy of the Standard may be stored on a single LAN file-server, or on the permanent storage device of a multiple-user computer, or on an Intranet server. The number of concurrent users shall not exceed the number of users authorized.

Electronic Standards are intended for on-line use, such as for viewing the requirements of a Standard, conducting a word search, and the like. Only one copy of the Standard may be printed from each single-user version of an electronic Standard. Only one copy of the Standard may be printed for each authorized user of a multiple-user version of an electronic Standard. Because of differences in the computer/software/printer setup used by UL and those of electronic Standards purchasers, the printed copy obtained by a purchaser may not look exactly like the on-line screen view or the printed Standard.

An employee of an organization purchasing a UL Standard can make a copy of the page or pages being viewed for their own fair and/or practical internal use.

The requirements in this Standard are now in effect, except for those paragraphs, sections, tables, figures, and/or other elements of the Standard having future effective dates as indicated in the note following the affected item. The prior text for requirements that have been revised and that have a future effective date are located after the Standard, and are preceded by a "SUPERSEDED REQUIREMENTS" notice.

New product submittals made prior to a specified future effective date will be judged under all of the requirements in this Standard including those requirements with a specified future effective date, unless the applicant specifically requests that the product be judged under the current requirements. However, if the applicant elects this option, it should be noted that compliance with all the requirements in this Standard will be required as a condition of continued Recognition and Follow-Up Services after the effective date, and understanding of this should be signified in writing.

Copyright © 2001 Underwriters Laboratories Inc.

This Standard consists of pages dated as shown in the following checklist:

Page	Date
1-5 .....	October 19, 2001
6-7 .....	December 11, 2000
8-13 .....	July 28, 1995
14-15 .....	December 11, 2000
16 .....	July 28, 1995
17 .....	December 24, 1998
18-20 .....	July 28, 1995
21 .....	December 24, 1998
22-25 .....	July 28, 1995
26-28A .....	October 19, 2001
28B .....	December 11, 2000
29 .....	December 24, 1998
30-31 .....	December 11, 2000
32-35 .....	July 28, 1995
36-36B .....	October 19, 2001
37-38 .....	December 11, 2000
39-40B .....	December 24, 1998
41-45 .....	July 28, 1995
46 .....	July 28, 1996
47-48 .....	December 24, 1998
48A .....	October 19, 2001
48B .....	December 24, 1998
49-50 .....	July 28, 1995
51-52 .....	October 19, 2001
52A-52B .....	December 11, 2000
53-62 .....	July 28, 1995
63 .....	December 24, 1998
64-66 .....	July 28, 1995
67 .....	October 19, 2001
68-70 .....	July 28, 1995
A1-A2 .....	July 28, 1995
B1-B2 .....	December 11, 2000

No Text on This Page

**JULY 28, 1995**  
(Title Page Reprinted: October 19, 2001)

1

**UL 1083**

**Household Electric Skillets and Frying-Type Appliances**

First Edition – April, 1973  
Second Edition – November, 1979  
Third Edition – August, 1987

**Fourth Edition**

**July 28, 1995**

Approval as an American National Standard (ANSI) covers the numbered paragraphs on pages dated July 28, 1995. These pages should not be discarded when revised or additional pages are issued if it is desired to retain the ANSI approved text.

An effective date included as a note immediately following certain requirements is one established by Underwriters Laboratories Inc.

Approved as ANSI C33.112-1972, January 20, 1972  
Approved as ANSI/UL 1083-1987, May 28, 1987  
Approved as ANSI/UL 1083-1995, February 6, 1995

Revisions of this Standard will be made by issuing revised or additional pages bearing their date of issue. A UL Standard is current only if it incorporates the most recently adopted revisions, all of which are itemized on the transmittal notice that accompanies the latest set of revised requirements.

**ISBN 1-55989-890-9**

**COPYRIGHT © 1979, 2001 UNDERWRITERS LABORATORIES INC.**

No Text on This Page



## CONTENTS

FOREWORD .....	4
----------------	---

## INTRODUCTION

1 Scope .....	5
2 Components .....	5
3 Units of Measurement .....	6
4 References .....	6

## CONSTRUCTION

5 General .....	6
6 Frame and Enclosure .....	6
7 Assembly .....	13
8 Corrosion Protection .....	14
9 Supply Connections .....	15
9.1 General .....	15
9.2 Strain relief .....	17
9.3 Pin terminals .....	17
9.4 Bushings .....	18
10 Current-Carrying Parts .....	21
11 Internal Wiring .....	21
11.1 General .....	21
11.2 Protection of wiring .....	22
11.3 Splices .....	22
12 Heating Elements .....	23
13 Electrical Insulation .....	23
14 Thermal Insulation .....	24
15 Thermal Cutoffs .....	24
16 Lampholders .....	24
17 Switches .....	25
18 Dual Voltage Appliances .....	25
19 Limit Controls .....	25
19.1 General .....	25
19.2 Terminals of safety devices .....	26
20 Spacings .....	26
20.1 General .....	26
20.2 Barriers .....	26
21 Overheating Protection .....	27
22 Grounding .....	28
23 Protection Against Personal Injury .....	28
24 Dynamic Stability Test – Deep Fat Fryers, Cooker/Fryers, and Fondues .....	30

## PERFORMANCE

25 General .....	33
26 Power Input Test .....	33
27 Leakage Current Test .....	33
28 Operational Tests .....	35
29 Calibration Tests of Probe-Type Temperature Controls .....	35

29A Mechanical Abuse .....	.36
30 Normal Temperature Test .....	.36A
30.1 General .....	.36A
30.2 Specific test conditions .....	.41
31 Insulation Resistance and Leakage Current Tests as a Result of Moisture .....	.43
31.1 General .....	.43
31.2 Immersion .....	.43
31.3 Cool-Down Leakage Current .....	.44
32 Dielectric Voltage-Withstand Test .....	.46
33 Strain Relief Test .....	.47
33A Push-Back Relief Test .....	.47
34 Metal Enclosure Impact Test .....	.47
35 Deep Fat Fryer, Cooker/Fryer, and Fondue Cycling Test .....	.49
36 Handle and Feet Strength Tests .....	.50
36A Detachable Power-Supply Cord Separation Test – Deep-Fat Fryers, Cooker/Fryers, and Fondues .....	.51
37 Thermal Degradation Test .....	.52
38 Mechanical Endurance Test .....	.52
39 Broken Element Test .....	.52A
40 Abnormal Operation Test .....	.52A
40.1 General .....	.52A
40.2 Specific test conditions .....	.54
40.3 Deep-fat fryers/cooker-fryers/fondues .....	.54
40.4 Skilletes .....	.55
40.5 Waffle bakers, sandwich grills, hamburger makers and donut makers .....	.55
40.6 Corn poppers .....	.55
40.7 Griddles and crepe makers .....	.55
41 Temperature Probe Insertion Test .....	.56
42 Control Devices Tests .....	.56
42.1 Automatic controls .....	.56
42.2 Endurance .....	.56
43 Permanence of Marking .....	.57
44 Test for Permanence of Cord Tag – Deep Fat Fryers and Cooker/Fryers .....	.58
44.1 General .....	.58
44.2 Test method .....	.58

## MANUFACTURING AND PRODUCTION-LINE TESTS

45 Dielectric Voltage-Withstand Test .....	.59
46 Polarization and Grounding Continuity Tests .....	.61
46.1 Polarization test .....	.61
46.2 Continuity of grounding connection .....	.61
46.3 Electrical indicating device .....	.61

## RATING

47 Details .....	.61
------------------	-----

## MARKING

48 Details .....	.61
49 Carton Marking .....	.66

**INSTRUCTION MANUAL**

50 General .....66  
51 All Appliances .....68  
52 Specific Appliances .....69  
53 User Maintenance .....70

**APPENDIX A**

Standards for Components..... A1

**APPENDIX B**

Food Color Charts .....B1

## FOREWORD

A. This Standard contains basic requirements for products covered by Underwriters Laboratories Inc. (UL) under its Follow-Up Service for this category within the limitations given below and in the Scope section of this Standard. These requirements are based upon sound engineering principles, research, records of tests and field experience, and an appreciation of the problems of manufacture, installation, and use derived from consultation with and information obtained from manufacturers, users, inspection authorities, and others having specialized experience. They are subject to revision as further experience and investigation may show is necessary or desirable.

B. The observance of the requirements of this Standard by a manufacturer is one of the conditions of the continued coverage of the manufacturer's product.

C. A product which complies with the text of this Standard will not necessarily be judged to comply with the Standard if, when examined and tested, it is found to have other features which impair the level of safety contemplated by these requirements.

D. A product that contains features, characteristics, components, materials, or systems new or different from those covered by the requirements in this standard, and that involves a risk of fire or of electric shock or injury to persons shall be evaluated using appropriate additional component and end-product requirements to maintain the level of safety as originally anticipated by the intent of this standard. A product whose features, characteristics, components, materials, or systems conflict with specific requirements or provisions of this standard does not comply with this standard. Revision of requirements shall be proposed and adopted in conformance with the methods employed for development, revision, and implementation of this standard.

E. UL, in performing its functions in accordance with its objectives, does not assume or undertake to discharge any responsibility of the manufacturer or any other party. The opinions and findings of UL represent its professional judgment given with due consideration to the necessary limitations of practical operation and state of the art at the time the Standard is processed. UL shall not be responsible to anyone for the use of or reliance upon this Standard by anyone. UL shall not incur any obligation or liability for damages, including consequential damages, arising out of or in connection with the use, interpretation of, or reliance upon this Standard.

F. Many tests required by the Standards of UL are inherently hazardous and adequate safeguards for personnel and property shall be employed in conducting such tests.

## INTRODUCTION

### 1 Scope

1.1 These requirements cover portable electric household skillets and other frying-type appliances, rated at 125 V or less, for use in ordinary locations in accordance with the National Electrical Code.

1.2 Frying-type appliances in this standard include frying-pans, sauce-pans, griddles, corn poppers, deep fat fryers, fondues, tempuras, woks, waffle or sandwich makers, and other similar appliances which may or may not be thermostatically controlled.

1.3 These requirements do not cover skillets or frying-type appliances intended for outdoor use, warming trays, or appliances that are covered in individual requirements that are separate from this standard.

1.4 In the following text, a requirement which applies to one type of equipment coming within its scope (skillet, waffle-maker, and the like) will be so identified by a specific reference in that requirement to the type of equipment involved. In the absence of such specific reference or if the term "appliance" is employed, it is to be understood that the requirement applies to all of the types of equipment covered by the standard.

1.5 *Deleted October 19, 2001*

### 2 Components

2.1 Except as indicated in 2.2, a component of a product covered by this standard shall comply with the requirements for that component. See Appendix A for a list of standards covering components used in the products covered by this standard.

2.1 revised May 1, 2000

2.2 A component is not required to comply with a specific requirement that:

- a) Involves a feature or characteristic not required in the application of the component in the product covered by this standard, or
- b) Is superseded by a requirement in this standard.

2.3 A component shall be used in accordance with its rating established for the intended conditions of use.

2.3 revised May 1, 2000

2.4 Specific components are incomplete in construction features or restricted in performance capabilities. Such components are intended for use only under limited conditions, such as certain temperatures not exceeding specified limits, and shall be used only under those specific conditions.

2.4 revised May 1, 2000

### **3 Units of Measurement**

3.1 Values stated without parentheses are the requirement. Values in parentheses are explanatory or approximate information.

3.1 revised May 1, 2000

3.2 Unless indicated otherwise all voltages and current values mentioned in this standard are root-mean-square (rms).

### **4 References**

4.1 Any undated reference to a code or standard appearing in the requirements of this standard shall be interpreted as referring to the latest edition of that code or standard.

## **CONSTRUCTION**

### **5 General**

5.1 Only materials that are intended for the particular use shall be used in an appliance. It shall be made and finished with the degree of uniformity and grade of workmanship practicable in a well-equipped factory.

### **6 Frame and Enclosure**

6.1 The frame and enclosure of an appliance shall be strong and rigid enough to resist the abuses likely to be encountered during normal service. The degree of resistance inherent in the appliance shall preclude total or partial collapse with the attendant reduction of spacings, loosening or displacement of parts, and other serious defects which alone or in combination constitute an increase in the risk of fire, electric shock, or injury to persons.

6.2 An appliance shall be provided with an enclosure of material acceptable for the particular application, which shall house all electrical parts, except a supply cord that may present a risk of fire, electric shock, or injury to persons under any condition of use.

6.3 In the case of an appliance employing oil or grease in its cooking operation, special consideration is to be given to the need for an enclosure over the cooking compartment, and to the acceptability for the purpose of the material employed for such an enclosure.

6.4 Among the factors that shall be taken into consideration when an enclosure is being judged for acceptability are its:

- a) Physical strength,
- b) Resistance to impact,
- c) Moisture-absorptive properties,

- d) Combustibility,
- e) Resistance to corrosion, and
- f) Resistance to distortion at temperatures to which the enclosure may be subjected under conditions of normal or abnormal use.

For a nonmetallic enclosure, see the enclosure requirements in the Standard for Polymeric Materials – Use in Electrical Equipment Evaluations, UL 746C. A metal enclosure or enclosure part shall be tested in accordance with Metal Enclosure Impact Test, Section 34, for resistance to impact of this standard.

*Exception No. 1: When considering the abnormal and severe conditions tests of UL 746C, the appliance enclosure is to be judged under the abnormal operations tests of Abnormal Operation Test, Section 40, of this standard.*

*Exception No. 2: Thermoset materials need not be subjected to the relative thermal capability requirements of UL 746C. For a thermoset material operating at a temperature above its temperature rating, the 1000 hour aging test as outlined in 37.1 shall be conducted.*

6.5 A thermoplastic enclosure of an appliance provided with overheating protection (Overheating Protection, Section 21) need not comply with the flammability requirements of UL 746C if a material rated HB, and possessing 60 arcs minimum resistance to high current arc ignition, and 7 second minimum resistance to hot wire ignition is employed and all enclosure parts including ribs, grills, and the like are spaced a minimum 1/2 inch (12.7 mm) from uninsulated live parts.

6.5 revised December 24, 1998

6.6 Cast- and sheet-metal portions of the enclosure shall be no thinner than indicated in Table 6.1 unless the enclosure is found to be acceptable when judged under considerations such as are mentioned in 6.4.

**Table 6.1**  
**Minimum acceptable thicknesses of enclosure metal**

Metal	At small, flat, unreinforced surfaces and at surfaces that are reinforced by curving, ribbing, or the like or are otherwise of a shape and/or size to provide equivalent physical strength		At relatively large unreinforced flat surfaces	
	Inches	Millimeters	Inches	Millimeters
Die-cast	3/64	1.2	5/64	2.0
Cast malleable iron	1/16	1.6	3/32	2.4
Other cast metal	3/32	2.4	1/8	3.2
Uncoated sheet steel	0.026 <sup>a</sup>	0.66 <sup>a</sup>	0.026	0.66
Galvanized sheet steel	0.029 <sup>a</sup>	0.74 <sup>a</sup>	0.029	0.74
Nonferrous sheet metal	0.036 <sup>a</sup>	0.91 <sup>a</sup>	0.036	0.91

<sup>a</sup> Thinner sheet metal may be employed if found to be acceptable when the enclosure is judged under considerations such as those mentioned in 6.4.

6.7 Electrical parts of an appliance, except the radiating portion of an open-wire element of a waffle-maker-type appliance with removable grids and its terminal connections immediately adjacent to the radiating element, shall be so located or enclosed that protection against unintentional contact with uninsulated live parts will be provided.

6.8 The enclosure shall be constructed so that molten metal, burning insulation, flaming particles, or the like will not fall on the supporting surface.

6.9 The requirement in 6.8 necessitates that an enclosure bottom with an opening be provided with a barrier above or below the opening if the opening is:

- a) Under a motor unless:
  - 1) The structural parts of the motor or of the appliance provide the equivalent of such a barrier,
  - 2) The protection provided with the motor is such that no burning insulation or molten material falls to the surface that supports the appliance when the motor is energized under each of the following fault conditions:
    - i) Open main winding,
    - ii) Open starting winding,
    - iii) Starting switch short-circuited; and
    - iv) For a permanent-split-capacitor motor the capacitor is short circuited. The short circuit is to be applied before the motor is energized and the rotor is to be blocked,
  - 3) The motor is provided with a thermal motor protector (a protective device that is sensitive to both temperature and current) that prevents the temperature of the motor windings from becoming more than 125°C (257°F) under the maximum load under which the motor runs without causing the protector to cycle, and from becoming more than 150°C (302°F) with the rotor of the motor locked, or
  - 4) The motor complies with the requirements for impedance-protected motors.
- b) Under wiring, unless the wiring complies with the VW-1 flame test or the Vertical Flame Test described in the Reference Standard for Electrical Wires, Cables, and Flexible Cords, UL 1581.
- c) Under an unenclosed switch, transformer, relay, solenoid, and the like, unless it can be shown that malfunction of the component is not likely to result in a fire.
- d) Under field and factory-made splices and overload and overcurrent protective devices.

*Exception: A barrier need not be provided if the opening is not within the area under the component requiring a barrier as illustrated by Line D in Figure 6.1*



6.10 The barrier mentioned in 6.9 shall be:

- a) Of metal, ceramic or a material that would be acceptable as an enclosure in accordance with 6.4,
- b) Horizontal, and
- c) Located as indicated in Figure 6.1, and shall not have an area less than that described in Figure 6.1.

6.11 An opening in the enclosure that has a minor dimension of less than 1 inch (25.4 mm) is acceptable if a probe as illustrated in Figure 6.2, inserted through the opening, cannot be made to touch any uninsulated live part or film-coated wire that involves the risk of electric shock. The probe shall be applied in all possible articulated positions before, during, and after insertion.

6.12 An opening that has a minor dimension of 1 inch (25.4 mm) or more, in an enclosure, as illustrated in Figure 6.3, is acceptable if, within the enclosure, there is no uninsulated live part or film-coated wire less than, R distance from the inside edge of the perimeter of the opening and X distance from the plane of the opening. T equals the enclosure thickness, R equals X minus T, and X equals five times the diameter of the largest round rod that can be inserted through the opening but not less than 6-1/16 inches (154 mm). In evaluating an opening, any barrier located within the volume is to be ignored unless it intersects the boundaries of the volume in a continuous, closed line.

**Figure 6.1**  
**Location and extent of barrier**

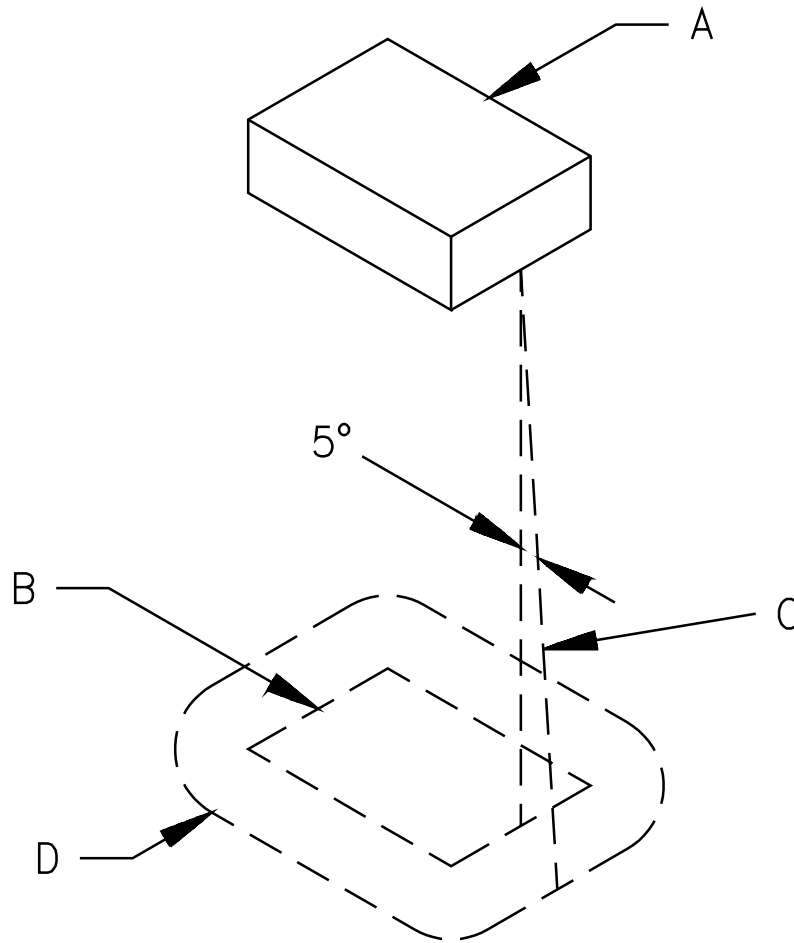

EB120A

A – Region to be shielded by barrier. This will consist of the entire component if it is not otherwise shielded and will consist of the unshielded portion of a component that is partially shielded by the component enclosure or equivalent.

B – Projection of outline of component on horizontal plane.

C – Inclined line that traces out minimum area of barrier. The line is always

- 1) tangent to the component,
- 2) 5 degrees from the vertical, and
- 3) so oriented that the area traced out on a horizontal plane is maximum.

D – Location (horizontal) and minimum area for barrier. The area is that included inside the line of intersection traced out by the inclined line C and the horizontal plane of the barrier.

Figure 6.2  
Accessibility probe

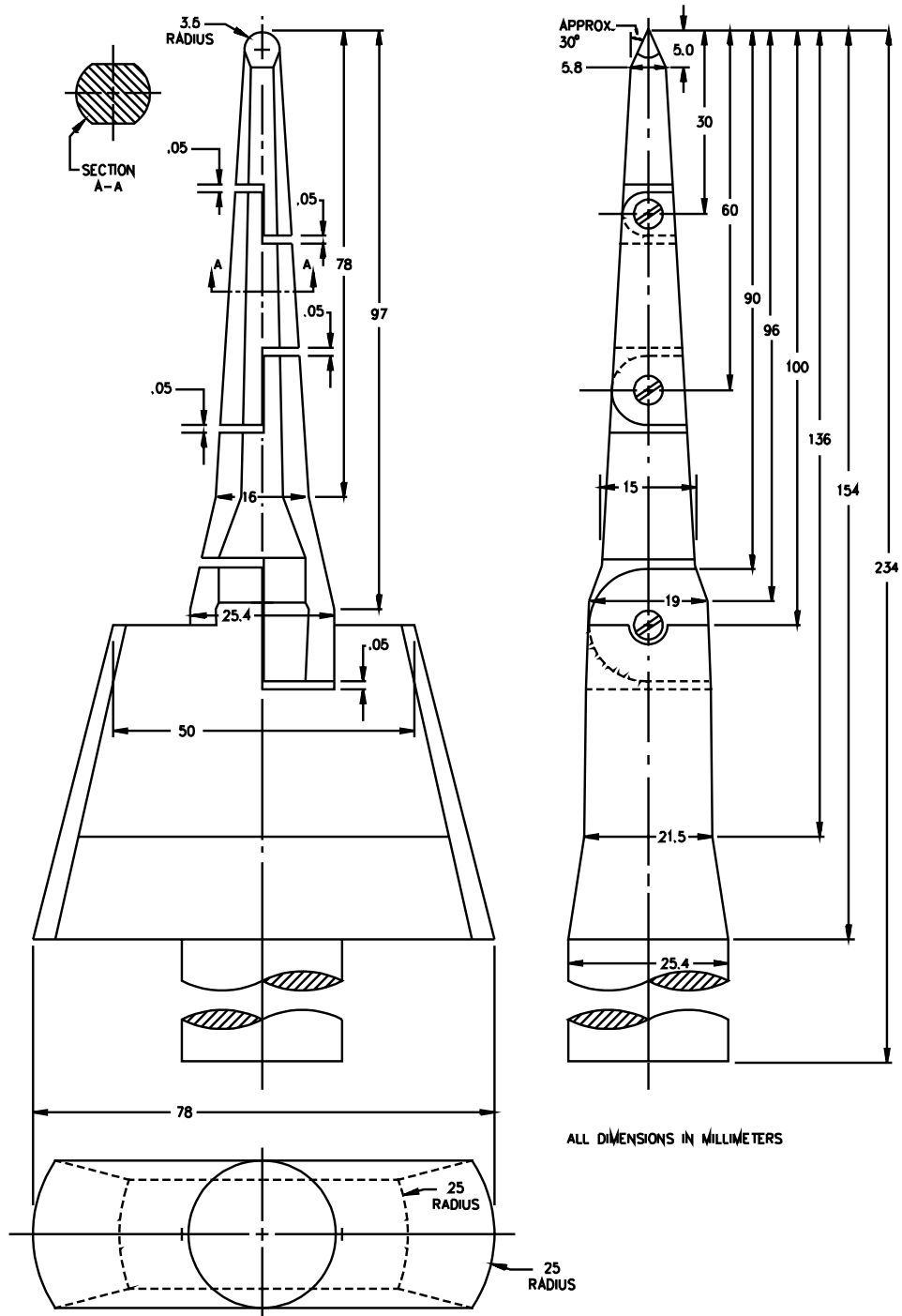

PA100A

**Figure 6.3**  
**Opening in enclosure**  
proportions exaggerated for clarity

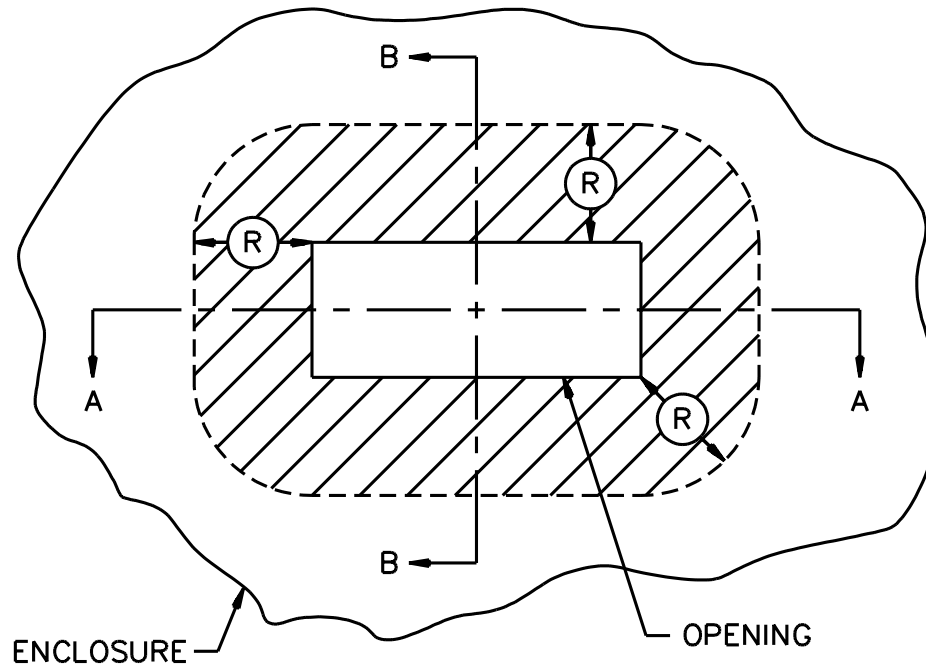

SECTION A-A  
( $X=R+T$ )

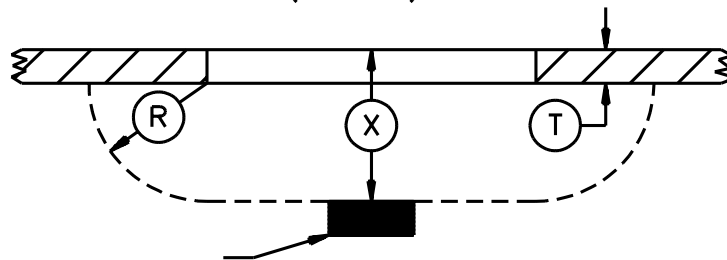

SECTION B-B  
( $X=R+T$ )

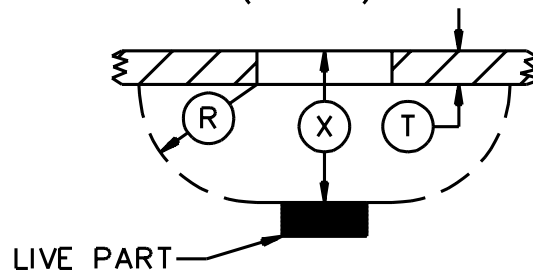

6.13 If a marking draws attention of the user to a hole of any size in the enclosure for the adjustment of a thermostat or for a similar activity, it shall not be possible to damage insulation or contact uninsulated live parts through the hole with a 1/16-inch diameter rod (1.6 mm).

6.14 During the examination of an appliance in connection with the requirements in 6.7 and 6.10 – 6.13, any part of the enclosure is to be disregarded – that is, it will not be assumed that the part in question affords protection against electric shock or injury to persons – if it either:

- a) Must be opened or removed, with or without the use of tools, to perform manufacturer's recommended user servicing, maintenance, operating adjustments, attachment of accessories, or other instructions, or
- b) Can be opened or removed without the use of tools.

*Exception: A part that requires a tool for opening or removal to perform manufacturer's recommended user servicing, maintenance, operating adjustments, attachment of accessories, or other instructions is to remain in place if the appliance is marked in accordance with 48.6.*

6.15 A component of an appliance that is likely to need inspection, replacement, cleaning, or other servicing shall be as accessible as possible. The component shall be readily accessible without the use of special tools (tools not available to other than service personnel) if it is intended to be manually operated or adjusted or periodically serviced.

6.16 A deep-fat fryer shall be so constructed that spillage of the hot fat on the heating element will be prevented.

6.17 The bulb and capillary tube of a thermostat shall be protected from mechanical damage if damage of the tube or bulb would increase the risk of fire.

## **7 Assembly**

7.1 A switch, lampholder, attachment-plug receptacle, or plug-type connector provided as a part of an appliance shall be mounted securely and prevented from turning by means other than friction between surfaces.

7.2 A lock washer properly applied is acceptable as a means to prevent turning of a stem-mounted switch.

7.3 Uninsulated live parts shall be so secured to the base or surface that they will be prevented from turning or shifting in position as the result of stresses if such motion may result in a reduction of spacings below the minimum required in 20.1.1 and 20.1.2.

7.4 Friction between surfaces is not acceptable as a means to prevent shifting or turning of live parts but a lock washer properly applied is acceptable.

7.5 Unless determined to be acceptable for the purpose, fastening of the handle assembly of a deep-fat fryer, cooker/fryer, or fondue appliance shall not rely on cement or equivalent materials alone. Mechanical means, such as pressure clamping, bosses and lances, and the like, shall be provided.

7.6 A handle assembly that is utilized to lift and tilt a deep-fat fryer, cooker/fryer, or fondue appliance shall comply with the requirements in 7.6 – 7.10, Table 30.1 and Sections 35 and 36.

7.7 A nonmetallic handle or feet of a deep-fat fryer, cooker/fryer, or fondue appliance shall be identified as required by the Standard for Polymeric Materials – Short Term Property Evaluations, UL 746A.

7.8 A handle of a deep-fat fryer, cooker/fryer, or fondue appliance shall be fastened so that a positive stop, interference screw or rivet, or other arrangement is provided so that with minor loosening, disengagement of the handle from the vessel will not result.

7.9 Iron and steel parts of a handle assembly of a deep-fat fryer, cooker/fryer, or fondue appliance shall be provided with corrosion protection in accordance with 8.1 or shall be constructed of stainless steel or other noncorrosive metal acceptable for the application.

7.10 A handle of a deep-fat fryer, cooker/fryer, or fondue appliance secured by a single fastening means shall be prevented from rotating by means other than friction. A lockwasher alone is not acceptable.

7.11 The feet of a deep-fat fryer, cooker/fryer, or fondue appliance shall comply with Deep Fat Fryer, Cooker/Fryer, and Fondue Cycling Test, Section 35.

## **8 Corrosion Protection**

8.1 Iron and steel parts shall be protected against corrosion by enameling, galvanizing, plating, or other equivalent means, if the malfunction of such unprotected parts would increase the risk of fire or electric shock.

*Exception: Where the oxidation of steel is not likely to be accelerated due to the exposure of metal to air and moisture or other oxidizing influence— thickness of metal and temperature also being factors – surfaces of sheet steel within an enclosure may not be required to be protected against corrosion. Cast-iron parts are not required to be protected against corrosion. A sheath employed on a heating element operating in air and terminal parts attached directly to the heating element need not be protected against corrosion.*

8.2 The aging characteristics of plating or other finish used in an appliance shall be such that deterioration of the finish will not result eventually in unacceptable performance of the appliance.

## 9 Supply Connections

### 9.1 General

9.1.1 An appliance shall be provided with a length of attached flexible cord and an attachment plug for connection to the supply circuit, or shall have male pin terminals that accommodate a detachable power-supply cord. The length of attached cord or detachable power-supply cord shall not be less than 2.0 ft (0.6 m), nor greater than 7.0 ft (2.1 m).

9.1.2 A deep fat-fryer, cooker/fryer and fondue shall be provided with a detachable power-supply cord having a cord length a minimum of 2 ft (0.6 m) and a maximum of 3 ft (0.9 m) long.

Revised 9.1.2 effective May 30, 2001

9.1.3 An appliance provided with a detachable power-supply cord or nondetachable power-supply cord less than 4-1/2 ft (1.4 m) in length shall be provided with instructions in accordance with 48.7.

9.1.4 If a flexible cord or detachable power-supply cord is provided with an appliance, the rating (both current and voltage) of the cord and the fittings, shall not be less than that of the appliance.

9.1.5 An attached flexible cord or a detachable power-supply cord that is provided with an appliance shall be Type HPD, HPN, HSJ, or HSJO or shall have such properties that it will be at least equally as serviceable for the particular application.

9.1.6 A 3- to 2-wire, grounding-type adapter shall not be provided with an appliance.

9.1.7 Supplementary insulation, if employed on a flexible cord, shall not extend more than 1/2 inch (13 mm) outside the appliance (unless provided with additional mechanical protection), shall be prevented from fraying or unraveling and shall not affect adversely the means for providing strain relief.

9.1.8 The attachment plug of the power-supply cord of an appliance provided with a 15- or 20- ampere general use receptacle shall be of the 3-wire grounding type. The attachment plug of the power-supply cord of an appliance provided with a manually operated, line-connected, single pole switch for appliance on-off operation or an Edison-base lampholder shall be of the polarized or grounding type.

9.1.9 If a 3-wire grounding-type attachment plug or a 2-wire polarized attachment plug is provided, the attachment plug connection shall comply with Figure 9.1 and the polarity identification of the flexible cord shall comply with Table 9.2.

9.1.10 The conductor of the power-supply cord that is intended to be grounded shall have the following items connected to it:

- a) The screw shell of an Edison-base lampholder and
- b) The terminal or lead of a receptacle intended to be grounded.

Table 9.2 identifies the supply cord conductor intended to be grounded.

**Figure 9.1**  
**Connections to attachment plug**

CONNECTIONS OF CORD CONDUCTORS TO GROUNDING – TYPE ATTACHMENT PLUG (FACE OF PLUG REPRESENTED)

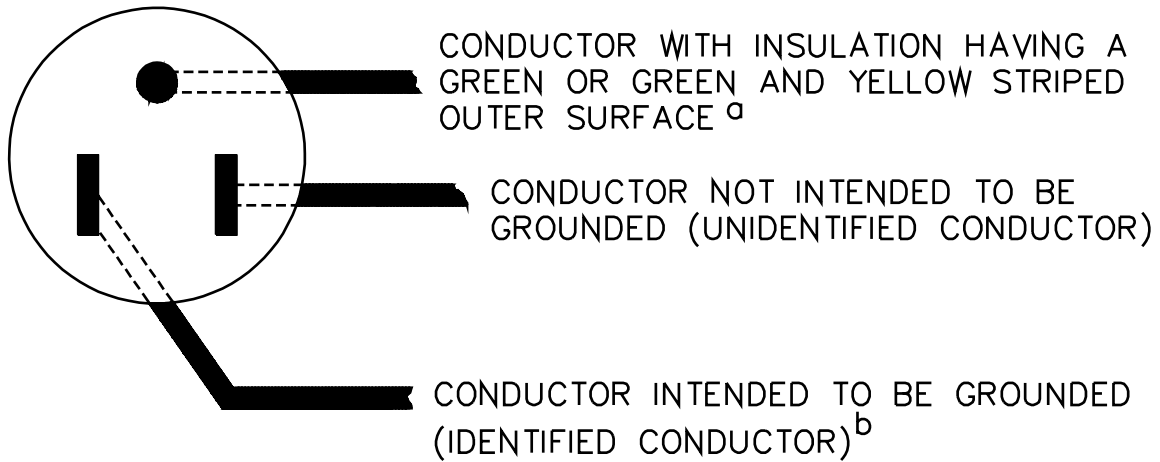

CONNECTIONS OF CORD CONDUCTORS TO POLARIZED ATTACHMENT PLUG (FACE OF PLUG REPRESENTED)

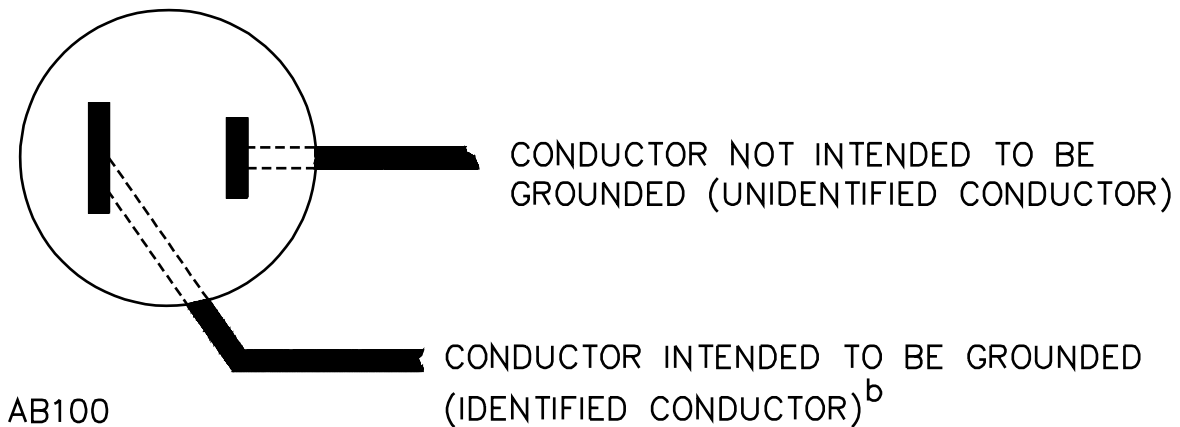

<sup>a</sup> In the above illustration, the blade to which the green conductor is connected may have a U-shaped or circular cross section.

<sup>b</sup> Signifies a conductor identified in accordance with Table 9.2.



## 9.2 Strain relief

9.2.1 Strain relief shall be provided to prevent a mechanical stress on an attached flexible supply cord from being transmitted to terminals, splices, or interior wiring.

9.2.2 If wood, pressed board, or other fibrous materials is used to secure the strain-relief assembly, the fibrous material shall be secured to the appliance by a pin, setscrew, or other positive means.

9.2.3 Means shall be provided to reduce the likelihood of an attached supply cord or lead from being pushed into the enclosure of an appliance through the cord-entry hole. To determine compliance with this requirement, the supply cord or lead shall be tested in accordance with Push-Back Relief Test, Section 33A.

9.2.3 revised December 24, 1998

9.2.4 If a knot serves as strain relief in an attached flexible cord, any surface with which the knot may come in contact shall be free from projections, sharp edges, burrs, fins, and the like, which may cause abrasion of the insulation on the conductors.

## 9.3 Pin terminals

9.3.1 If an appliance is provided with pin terminals, the design of the appliance shall be such that no live parts will be exposed to unintentional contact both during and after the placement of the plug on the pins, in the intended manner.

9.3.2 A pin guard is required, such that:

- a) A straight edge placed in any position, across and in contact with edges of the plug opening without the plug in place, cannot be made to contact any current-carrying pin.
- b) With the plug aligned with the pins and the face of the plug in a plane located perpendicular to the end or ends of the farthest projecting current-carrying pin, the probe illustrated in Figure 6.2 should not touch any current-carrying pin while the probe is inserted through any opening with the appliance in any position.

9.3.3 The plug used in accordance with 9.3.2(b) is to be the plug supplied with the appliance.

9.3.4 If an appliance employs three or more pin terminals intended for use with a plug that covers all the pins, the terminals shall be so spaced that they will not accommodate a flatiron or appliance plug or cord-connected body. The plug that these pins will accommodate shall be appropriate for the particular application.

9.3.5 If an appliance is provided with a user removable heating element, the heating element shall have a guard that shall:

- a) Be securely and rigidly mounted by means other than friction alone, and
- b) Prevent the heating element pins from being damaged, shorting to the appliance enclosure during insertion or removal, and shifting in position relative to each other.

9.3.6 A pin terminal shall be securely and rigidly mounted and shall be prevented from shifting in position by means other than friction between surfaces.

9.3.7 The requirement in 9.3.6 is intended primarily to provide for the maintenance of spacings as given in 20.1.1 and to provide for the maintenance of proper spacings between pin terminals. Under this requirement, consideration is also to be given to the means for locking terminals in position to maintain tightness.

9.3.8 The dimensions of pins and their center-to-center spacings (including the corresponding spacings of the female contacts of general-use plugs that these arrangements of pins will accommodate) are as indicated in Table 9.1.

9.3.9 An appliance provided with three pin terminals, one of which is for grounding, shall not be provided with or capable of being used with a two-conductor detachable power-supply cord.

9.3.10 An appliance provided with two pin terminals shall not be provided with or capable of being used with a three-conductor detachable power-supply cord employing a grounding conductor.

#### **9.4 Bushings**

9.4.1 At a point where a flexible cord passes through an opening in a wall, barrier, or enclosing case, there shall be an acceptable bushing or the equivalent that shall be substantial, reliably secured in place, and shall have a smooth, well-rounded surface against which the cord may bear. If Type HPN flexible cord or lighter is employed, if the wall or barrier is of metal, and if the construction is such that the cord may be subjected to strain or motion, an insulating bushing shall be provided. The heat- and moisture-resistant properties of the bushing material shall be such that the bushing is acceptable for the particular application.

9.4.2 If the cord hole is in porcelain, phenolic composition, or other nonconducting material, a smooth, well-rounded surface is considered to be equivalent to a bushing.

9.4.3 Ceramic materials and some molded compositions are acceptable generally for insulating bushings, but a separate bushing of wood, hot-molded shellac and tar composition, or rubber material is not acceptable. Vulcanized fiber may be employed if the bushing is not less than 3/64 inch (1.2 mm) thick, and if it is so formed and secured in place that it will not be affected adversely by conditions of ordinary moisture.

9.4.4 An insulated metal grommet may be accepted in place of an insulating bushing if the insulating material used is not less than 1/32 inch thick (0.8 mm), and completely fills the space between the grommet and the metal in which it is mounted.

**Table 9.1**  
**Pins of appliance and flatiron plugs**

Type and rating of plug that accommodates the pins	Configuration of pins			Dimensions of pins	
	Number	Arrangement	Spacing between centers, inch(mm)	Diameter, inch(mm)	Length, inch(mm)
Appliance plug rated 10 A at 125 V	2	In line	1/2 (12.7)	0.156 ±0.005 (4.0 ±0.13)	9/16 – 5/8 (14.3 – 15.9)
Flatiron plug rated 10 A at 125 V	2	In line	11/16 (17.5)	0.188 ±0.005 (4.8 ±0.13)	3/4 – 7/8 (19.0 – 22.2)
Jumbo appliance plug rated 15 A at 125 V and	2	In line	1-1/16 (27.0)	0.188 ±0.005 (4.8 ±0.13)	3/4 – 7/8 (19.0 – 22.2)
Reversible plug (for two-heat control) rated 15 A at 125 V <sup>a</sup>	3	In line	7/8 (22.2)	0.188 ±0.005 (4.8 ±0.13)	3/4 – 7/8 (19.0 – 22.2)
Reversible plug (for two-or three-heat control) rated 15 A at 125 V <sup>a</sup>	3	One pin at apex of an equilateral triangle	7/8 (22.2)	0.188 ±0.005 (4.8 ±0.13)	3/4 – 7/8 (19.0 – 22.2)

<sup>a</sup> Usually this plug is made without a contact in one of the holes.

**Table 9.2**  
**Polarity identification of flexible cords**

Method of identification	Acceptable combinations		
	Wire intended to be grounded <sup>d</sup>		All other wires <sup>d</sup>
Color of braids on individual conductors	A	Solid white or natural gray – without tracer	Solid color other than white or natural gray – without tracer
	B	Color other than white or natural gray, with tracer in braid	Solid color other than white or natural gray – without tracer
Color of insulation on individual conductors	C <sup>a</sup>	Solid white or natural gray	Solid color other than white or natural gray
	C1 <sup>e</sup>	Light blue	Solid color other than light blue, white or natural gray
Color separators	D <sup>b</sup>	White or natural gray	Color other than white or natural gray
Other means	E <sup>c</sup>	Tin or other white metal on all strands of the conductor	No tin or other white metal on the strands of the conductor
	F <sup>b</sup>	A stripe, ridge, or groove on the exterior surface of the cord	

<sup>a</sup> Only for cords—other than Type SP-1, and SPT-1—having no braid on any individual conductor.  
<sup>b</sup> Only for Types SP-1, SP-2, SPT-1, and SPT-2 cords.  
<sup>c</sup> Only Type SPT-1, and SPT-2 cords.  
<sup>d</sup> A wire finished to show a green color with or without one or more yellow stripes or tracers is to be used only as an equipment grounding conductor. See 22.1 and Figure 9.1.  
<sup>e</sup> For jacketed cord.

## 10 Current-Carrying Parts

10.1 Each current-carrying part shall be made of metal that is appropriate for the particular application.

10.2 Current-carrying parts made of corrosion-resistant alloys (for example, stainless steel) are acceptable regardless of temperature. Current-carrying parts made of ordinary iron and steel are not acceptable unless they are rendered corrosion-resistant by an appropriate coating and, even then, they are acceptable only as follows:

- a) Pin terminals.
- b) Parts whose normal operating temperature is higher than 100°C (212°F).
- c) Parts of a component that the requirements referred to in 2.1 indicate as being acceptable with coated iron and steel parts.

10.3 If a reservoir is part of a heating appliance, all live parts shall be so located or projected that they will not be subject to dripping if the reservoir leaks, unless:

- a) The reservoir is resistant to corrosion from the liquid intended for use in it, and
- b) The reservoir does not develop cracks as a result of aging.

## 11 Internal Wiring

### 11.1 General

11.1.1 The internal wiring of an appliance shall consist of wires of adequate size and of a type or types which are appropriate for the particular application, when considered with respect to:

- a) The temperature and voltage to which the wiring is likely to be subjected,
- b) Exposure to oil or grease, and
- c) Other conditions of service to which it is likely to be subjected.

11.1.2 There is no temperature limit applicable to unimpregnated glass fiber, beads of inorganic material, or the equivalent employed as conductor insulation.

11.1.2 revised December 24, 1998

11.1.3 Thermoplastic-insulated wire employed for the internal wiring of an appliance shall be fixture wire, or appliance-wiring material appropriate for the particular application.

11.1.3 revised December 24, 1998

## 11.2 Protection of wiring

11.2.1 The wiring and connections between parts of a waffle-maker-type appliance shall be protected or enclosed, except that a length of flexible cord may be employed for external connections, or for internal connections that may be exposed during servicing, if flexibility of the wiring is essential. A bare conductor or a conductor with beads for insulation shall not be used outside an enclosure.

11.2.2 Internal wiring that is exposed through an opening in the enclosure of a waffle-maker-type appliance is considered to be protected as required in 11.2.1 if, when judged as if it were enamel-insulated wire, the wiring would be acceptable according to 6.7 – 6.11. Internal wiring not so protected may be accepted if it is so secured within the enclosure that it is unlikely to be subjected to stress or mechanical damage.

11.2.3 If the wiring of an appliance is so located that it may be in proximity to combustible material or may be subjected to mechanical injury, it shall be protected.

11.2.4 Wires within an enclosure, compartment, raceway, or the like shall be so located or protected that damage to conductor insulation can not result from contact with any rough, sharp, or moving part.

11.2.5 A hole by means of which insulated wires pass through a sheet-metal wall within the overall enclosure of an appliance shall be provided with a smooth, well-rounded bushing or shall have smooth, well-rounded surfaces upon which the wires may bear, to prevent abrasion of the insulation.

11.2.6 Insulated wires may be bunched and passed through a single opening in a metal wall within the enclosure of an appliance.

## 11.3 Splices

11.3.1 All splices and connections shall be mechanically secure and shall provide good electrical contact. A soldered connection shall be made mechanically secure before being soldered if breaking or loosening of the connection may result in a risk of fire or electric shock.

11.3.2 A splice shall be provided with insulation equivalent to that of the wires involved if permanence of spacings between the splice and other metal parts of the appliance is not reliably maintained.

11.3.3 Insulation consisting of two layers of friction tape, two layers of thermoplastic tape, or of one layer of friction tape on top of one layer of rubber tape, is acceptable on a splice. In determining whether splice insulation consisting of coated fabric, thermoplastic, or other type of tubing is acceptable, consideration is to be given to such factors as its dielectric properties, heat-resistant and moisture-resistant characteristics. Thermoplastic tape wrapped over a sharp edge is not acceptable.

11.3.4 Where stranded internal wiring is connected to a wire-binding screw, loose strands of wire shall be positively prevented from contacting any other uninsulated live part that is not always of the same polarity as the wire, and from contacting any dead metal part. This may be accomplished by the use of pressure terminal connectors, soldering lugs, crimped eyelets, soldering all strands of the wire together, or other equivalent means.

## 12 Heating Elements

12.1 A heating element shall be adequately supported. It shall be protected against mechanical damage and contact with outside objects.

12.2 In determining that a heating element is adequately supported, consideration is to be given to sagging, loosening, and other adverse conditions of the element resulting from continuous heating. For an open-wire (uninsulated resistance wire) heating element consideration is also to be given to breakage at any point.

12.3 Except for a waffle baker grill with removable grids (see 17.3 and 19.1), a heating element in an appliance which may be contacted by the user during use or cleaning shall not be of the open-wire construction.

12.4 An open-wire element, that is, uninsulated resistance wire, may be used in an appliance provided it is enclosed or protected by barriers or covers that require tools for removal, and it complies with the accessibility of live parts requirements outlined in 6.7 and 6.11 – 6.14 and the broken element test of Broken Element Test, Section 39.

12.5 A sheathed element, rope heater, or the like shall be judged under the applicable requirements of this standard.

## 13 Electrical Insulation

13.1 Insulating washers, bushings, and the like, which are integral parts of a heating appliance and bases or supports for the mounting of current-carrying parts shall be of a moisture-resistant material which will not be damaged by the temperatures to which they will be subjected under conditions of actual use. Molded parts shall be so constructed that they will have adequate mechanical strength and rigidity to withstand the stresses of actual service.

13.2 Insulating material employed in an appliance shall be judged with respect to its acceptability for the particular application. Materials such as mica, some molded compounds, and certain refractory materials are usually acceptable for use as the direct support of live parts. Other materials which are not acceptable for general use, such as magnesium oxide, may be acceptable if used in conjunction with other more appropriate insulating materials or if located and protected against mechanical damage and the absorption of moisture is minimized. When it is necessary to investigate a material to determine whether it is acceptable, consideration is to be given to its mechanical strength, dielectric properties, insulation resistance, heat-resistant qualities, the degree to which it is enclosed or protected, and any other features having a bearing on the risk of fire, electric shock, or injury to persons involved, in conjunction with conditions of actual service. All these factors are considered with respect to thermal aging. The appropriate tests in the Standard for Polymeric Materials – Use in Electrical Evaluations, UL 746C, see Electrical Insulation Section, are to be used to evaluate a material for the above-mentioned properties.

*Exception: Thermoset materials need not be subject to the relative thermal capability requirements in UL 746C. For a thermoset material operating at a temperature above its temperature rating, the 1000 hour Aging Test as outlined in 37.1 shall be conducted.*

13.3 In the mounting or supporting of small, fragile insulating parts, screws or other fastenings should not be tight enough to cause cracking or breaking of these parts with expansion and contraction. Generally, such parts should be slightly loose.

13.4 Sleeving or tubing used as an insulator for uninsulated live parts (such as glass fiber in rope heaters) shall be so disposed or protected that no damage to the sleeving or tubing can result from contact with any rough, sharp, or moving part. The sleeving or tubing shall not be installed under a compression that renders it incapable of complying with the dielectric voltage-withstand requirements in 32.1.

#### **14 Thermal Insulation**

14.1 Thermal insulation, if employed, shall be of such a nature and so located and mounted or supported that it will not be adversely affected by any intended operation of the appliance.

14.2 Combustible or electrically conductive thermal insulation shall not contact uninsulated live parts of an appliance.

14.3 Some types of mineral-wool thermal insulation contain conductive impurities in the form of slag, which make its use unacceptable if in contact with uninsulated live parts. See 31.1.1

#### **15 Thermal Cutoffs**

15.1 If an appliance is provided with a thermal cutoff, it shall be secured in place and shall be so located that it will be accessible for replacement without damaging other connections or internal wiring. See 48.6.

15.2 If an appliance is provided with a thermal cutoff, it shall be capable of opening the circuit in the intended manner without causing the short-circuiting of live parts and without causing live parts to become grounded to the enclosure when the appliance is connected to a circuit of voltage in accordance with 30.1.12, and operated in a normal position to cause abnormal heating.

15.3 To determine whether a thermal cutoff complies with the requirement in 15.2, the appliance is to be operated with separate links five times as described above while any other thermally operated control devices in the appliance are short-circuited. Each link is required to perform acceptably. During the test, the enclosure is to be connected through a 3-A fuse to a supply conductor not containing the thermal cutoff.

#### **16 Lampholders**

16.1 A lampholder supplied as a part of an appliance equipped with a polarized or grounding type attachment plug shall be so wired that the screw shell is connected to the grounded conductor.

16.2 Except as noted in 16.3, a lampholder shall be so designed and installed that uninsulated live parts other than the screw shell will not be exposed to contact by persons removing or replacing lamps in normal service.

16.3 The requirement in 16.2 does not apply if, in order to remove or replace a lamp, it is necessary to dismantle the appliance by means of tools.



## 17 Switches

17.1 A switch or other control device provided as a part of an appliance shall have a current and voltage rating not less than that of the circuit (load) which it controls.

17.2 A switch employed on an appliance shall be so located or protected that it will not be subjected to mechanical damage in normal use.

17.3 A switch on a waffle-maker-type appliance with removable grids shall be of such a type and so connected that it will disconnect any open-wire element or elements that it controls from all conductors of the supply circuit.

17.4 The requirement in 17.3 applies to a switch in the "off" position or any other setting in which the element is not heated, and also to a through-cord switch or a plug in which a switch is incorporated in a detachable or non-detachable power-supply cord that is provided with such a heating appliance.

17.5 A manually operated, line-connected, single pole switch for appliance on-off operation shall not be connected to the conductor of the power supply cord intended to be grounded. Table 9.2 specifies the identification of the power supply cord conductor intended to be grounded.

17.6 A switch shall not be incorporated in a wooden handle or in other combustible material unless enclosed in metal or an acceptable insulating material.

## 18 Dual Voltage Appliances

18.1 The construction of the circuit voltage selector shall be such that the circuit voltage setting cannot be changed inadvertently.

18.2 If the appliance is so constructed that the supply circuit voltage selector can be changed, the action of changing the voltage selector setting shall also change the supply circuit voltage indication.

18.3 An appliance that can be set to different rated supply circuit voltages shall be provided with the statement required by 52.6.

## 19 Limit Controls

### 19.1 General

19.1.1 The operation of an auxiliary control device in a waffle-maker-type appliance with removable grids shall disconnect the element or elements which it controls from all ungrounded conductors of the supply circuit.

19.1.2 A safety or temperature-limiting control designed to prevent risk of fire or electric shock shall be operative whenever the appliance is connected to its power supply.

19.1.3 A control device shall not be designed to deliberately overload the branch-circuit protective device as a means of disconnecting the appliance from the supply.

## 19.2 Terminals of safety devices

19.2.1 The terminals of a safety device within the enclosure of a heating appliance shall be so located or further enclosed that they will be protected against unintentional short-circuiting and damage.

## 20 Spacings

### 20.1 General

20.1.1 The spacings through air and over surface in an appliance shall not be less than 1/16 inch (1.6 mm) between uninsulated live parts of opposite polarity; and between a rigidly mounted uninsulated live part and a dead metal part that either is exposed for persons to contact or may be grounded.

*Exception No. 1: If exact centering of the cold pin of a sheathed-type heating element is required to maintain the 1/16 inch (1.6 mm) spacing, a spacing of 3/64 inch (1.2 mm) in one location is acceptable.*

*Exception No. 2: Spacings in an appliance that comply with 20.1.2 need not comply with 20.1.1.*

20.1.2 At closed-in points only, such as the screw-and-washer construction of an insulated terminal mounted in metal, a spacing of 3/64 inch (1.2 mm) is acceptable. Within a thermostat, except at contacts, the spacings between uninsulated live parts on opposite sides of the contacts are to not be less than 1/32 inch (0.8 mm) through air and 3/64 inch (1.2 mm) over the surface of insulating material, and the construction is to be such that the spacings will be maintained permanently.

### 20.2 Barriers

20.2.1 An insulating liner or barrier of fiber or similar material employed where spacings would otherwise be unacceptable, shall not be less than 0.032 inch (0.8 mm) thick and shall be so located or of such material that it cannot be adversely affected by arcing, except that fiber not less than 0.016 inch (0.4 mm) thick may be used in conjunction with an air spacing of not less than 50 percent of the spacing required for air alone.

*Exception: Insulating material having a thickness less than specified may be used if it is acceptable for the application.*

20.2.2 Unless protected from mechanical abuse during assembly and normal functioning of an appliance, a barrier of mica shall be 0.010 inch (0.25 mm) or thicker.

## 21 Overheating Protection

21.1 The requirements in 21.2 – 21.5 are applicable to a cooker/fryer, deep fat fryer and fondue that do not employ probe-type temperature controls or an appliance provided with an enclosure complying with 6.5. These requirements are in addition to or modify the applicable requirements in Sections 15, 20 and 40.

21.2 An appliance shall be provided with a separate and distinct temperature-limiting device to limit temperatures within the appliance. A single combination regulating-limiting control is unacceptable for this purpose.

*Exception: A temperature-limiting device is not required if, with all thermally responsive devices short-circuited, the results of all appropriate abnormal tests in Abnormal Operation Test, Section 40, are acceptable.*

21.3 A limiting device shall be any one-time device or manual-reset thermostat, inaccessible to the user, (see 6.11 – 6.14) that performs its intended function when tested according to these requirements.

21.4 A single-operation thermostat or a manual-reset thermostat that is provided as the temperature-limiting device shall comply with the applicable requirements for Single-Operation Devices in the Standard for Temperature-Indicating and -Regulating Equipment, UL 873.

*Exception: A thermostet that complies with 21.6 need not comply with 21.4.*

21.5 A thermal cutoff that is provided as a temperature-limiting device shall comply with the applicable requirements in the Standard for Thermal Cutoffs for Use in Electrical Appliances and Components, UL 1020.

*Exception: A thermal cutoff that complies with 21.6 need not comply with 21.5.*

21.6 A thermostat or thermal cutoff need not comply with a specific requirement in the standard indicated in 21.4 and 21.5, respectively, if the requirement:

- a) Involves a feature or characteristic not needed in the application of the component in the product, or
- b) Is superseded by a requirement in this standard.

## 22 Grounding

22.1 On an appliance where grounding is required or provided, the flexible cord shall include a grounding conductor that shall be:

- a) Green with or without one or more yellow stripes,
- b) Connected to the grounding blade of an attachment plug of a grounding type, and
- c) Connected to the enclosure of the appliance by means of a screw not likely to be removed during ordinary servicing, or by other equivalent means. Solder alone is not acceptable for making this connection.

22.2 All exposed dead metal parts of a cord-connected appliance that is equipped with a grounding-conductor, and all dead metal parts within the enclosure that are exposed to contact during any user serving and are likely to become energized, shall be conductively connected to the grounding conductor of the power-supply cord.

22.3 A separable connecting device provided with a grounding connection shall be such that the appliance grounding connection is made before connection to, and broken after disconnection from the supply circuit.

*Exception: An interlocking plug, receptacle, and connector that is not energized when the appliance grounding connection is made.*

## 23 Protection Against Personal Injury

23.1 Materials employed in the construction of the appliance depended upon to reduce the risk of personal injury shall be appropriate for the particular use. See 6.1 and 6.4.

23.2 An enclosure, a frame, a guard, a handle, or the like shall not be sufficiently sharp to constitute a risk of injury to persons during normal maintenance and use.

*Exception No. 1: A part or portion of a part needed to perform a working function need not comply with this requirement.*

*Exception No. 2: A part or portion of a part inaccessible to the probe illustrated in Figure 6.2 need not comply with this requirement.*

23.3 Compliance with the requirement of 23.2 is determined by applying the test procedures, equipment, and acceptance criteria described in the requirements for test for sharpness of edges on equipment, UL 1439.

23.4 The stability of an appliance shall be such that it will not be overturned readily in normal use.

23.5 The appliance shall be placed on a plane inclined at an angle of 15° to the horizontal. The appliance shall be positioned and loaded with whatever combination of separable components, liquid, or other media (material) that results in the maximum tendency to overturn under conditions of normal use.

23.6 A deep fat fryer, cooker/fryer, or fondue appliance shall be placed on a plane inclined at an angle of 30 degrees to the horizontal. The appliance shall be positioned and loaded with whatever combination of separable components baskets, liquid or other media (material) that results in the maximum tendency to overturn under conditions of intended use. The appliance shall be prevented from sliding on the inclined surface. The appliance shall not tip-over, and shall not spill any of the liquid as a result of this test.

23.7 A deep fat fryer, cooker/fryer, or fondue appliance shall not tip over when subject to a 0.75 ft-lbf (102 N·m) impact as described in 23.8.

23.8 With reference to 23.7 a deep fat fryer, cooker/fryer, or fondue appliance is to be subjected to an impact of 0.75 ft-lbf (1.02 N·m) on a horizontal surface consisting of laminated thermosetting counter top type material adhered to a wood base surface rigidly fixed for the intended use. 1/8 inch (3.2 mm) thick (uncompressed) polyurethane foam material, such as that used for packing, is to be placed under the bottom of the appliance to prevent sliding. The appliance is to be positioned and loaded to full capacity with the oil solidified in the position obtained during determination of the tip-over angle  $\alpha_2$ .

23.9 A sphere, illustrated in Figure 23.1, is to be suspended from a cord and allowed to swing as a pendulum in such a manner as to strike the appliance with an impact of 0.75 ft-lbf (1.02 N·m) at a point most likely to cause tip-over.

No Text on This Page

**Figure 23.1**  
**Ball for dynamic stability test**  
 Figure 23.1 revised December 24, 1998

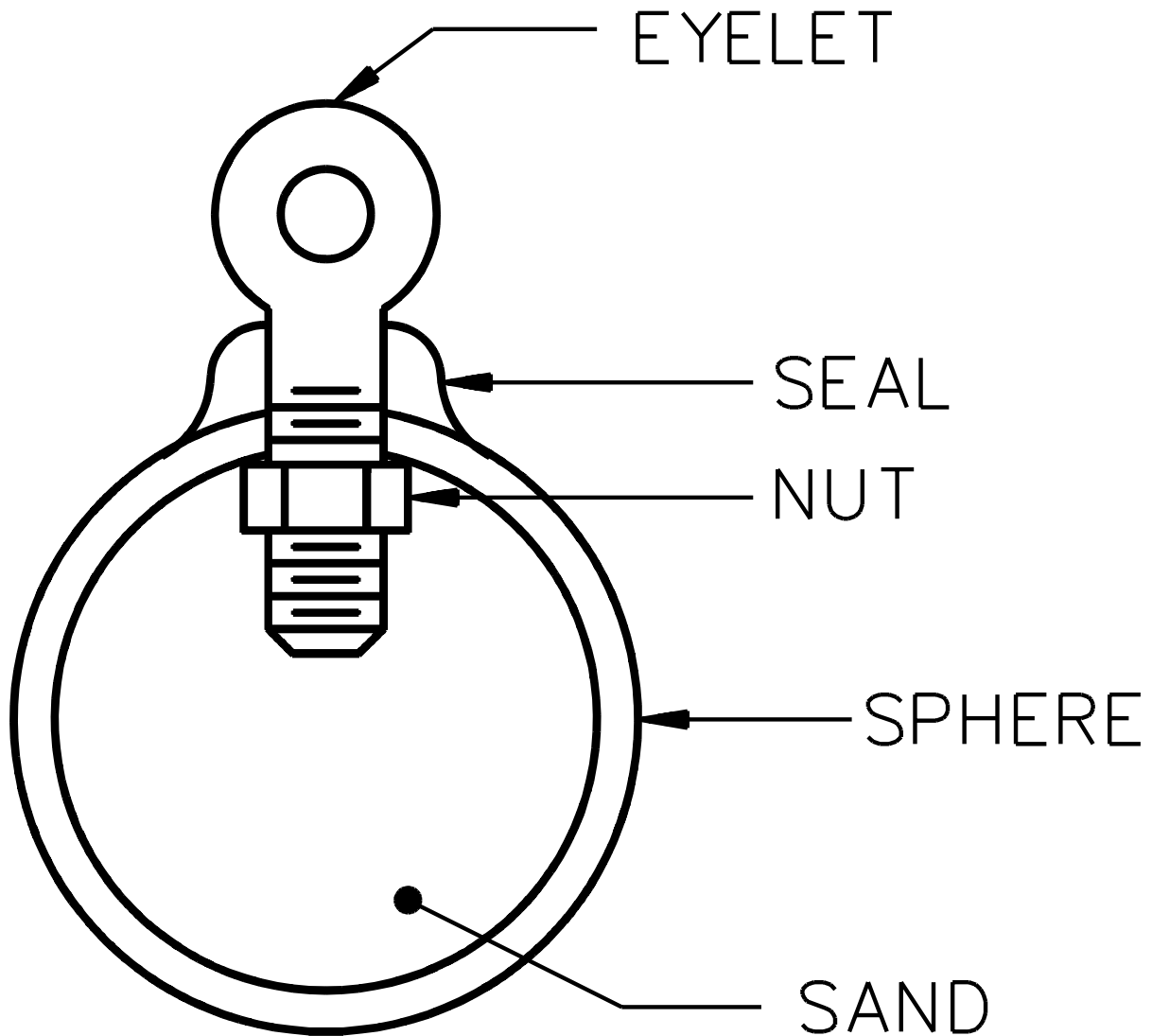

SA0530M

Eyelet –	1-1/2 inches (38 mm) long, No. 10, steel.
Seal –	Silicone rubber.
Sphere –	Natural rubber or neoprene. Hollow with 1/32 – 3/32 inch (0.8 – 2.4 mm) thick wall. 2-1/8 – 2-3/8 inch (54 – 60 mm) diameter.
Sand –	No. 60 core.
Total Weight –	0.30 – 0.36 pounds (136.1 – 163.3 g)

23.10 The release mechanism for detachable handles shall be:

- a) So located and/or so guarded that inadvertent detachment of the handle does not occur during intended use of the appliance, and
- b) So constructed that complete and proper engagement of the handle is obvious to the user during the operation of attaching the handle.

23.11 Deep-fat fryer food basket handles shall be provided with integral parts that interlock so that the handle will not accidentally detach or collapse from the basket during use.

23.12 If proper positioning of any deep-fat fryer basket/handle part is essential to prevent accidental detachment or collapse of the basket handle, the part shall be permanently marked to indicate its function, namely "lock". The direction of locking shall also be indicated. See 50.3.

#### **24 Dynamic Stability Test – Deep Fat Fryers, Cooker/Fryers, and Fondues**

24.1 When a deep fat fryer, cooker/fryer, or fondue appliance is subject to the Dynamic Stability Test described in 24.2 – 24.10, the minimum tip-over angle [ $\alpha_2$ ] shall be more than 30 degrees and the calculated velocity to cause tip-over shall be more than 2 ft/s (0.61 m/s).

24.2 With the deep fat fryer, cooker/fryer, or fondue appliance, initially on a level surface, it is to be energized. While heated, it is to be filled to the recommended level with a commercially available vegetable shortening. After the shortening liquifies, the deep fat fryer is then to be allowed to cool until the vegetable shortening solidifies.

24.3 The deep fat fryer, cooker/fryer, or fondue appliance is then to be placed against a low stop on an inclined plane. The angle of inclination is to be increased until the deep fat fryer, cooker/fryer, or fondue appliance becomes unstable and begins to overturn. By repeating this process with the deep fat fryer, cooker/fryer, or fondue appliance rotated in various positions against the low stop, the position that is least stable is to be determined. This minimum angle to cause tipover is to be recorded as  $\alpha_1$ . See A of Figure 24.1.

24.4 The deep fat fryer, cooker/fryer, or fondue appliance is to be rotated 180 degrees on the inclined plane and the angle increased until the deep fat fryer, cooker/fryer, or fondue appliance becomes unstable and begins to tip-over. This angle is to be recorded as  $\beta_1$ . See B of Figure 24.1.

24.5 The deep fat fryer, cooker/fryer, or fondue appliance is to be again heated while on a level surface until the shortening liquifies.

24.6 The deep fat fryer, cooker/fryer, or fondue appliance is to be oriented on the inclined plane against the low stop in the same position as used for the measurement of  $\alpha_1$ .

24.7 The angle of the inclined plane is to be increased (allowing the liquified vegetable shortening to displace) until instability occurs or the oil starts to spill out. The deep fat fryer, cooker/fryer, or fondue appliance is to be deenergized and held at that angle until the vegetable shortening again solidifies. This angle is recorded as  $\alpha_2$ . See C of Figure 24.1.



24.8 With the vegetable shortening still solidified, the deep fat fryer, cooker/fryer, or fondue appliance is to be rotated 180 degrees against the low stop and the tip-over angle measured. This angle is to be recorded Beta 2 ( $\beta_2$ ). See D of Figure 24.1.

24.9 The base dimension B (the distance between the two fulcrum points) is to be recorded.

24.10 The velocity to cause tip-over is to be calculated from the equation.

$$v = \sqrt{2g(\sqrt{h_2^2 + d_2^2} - h_1)} = \sqrt{2g\left[\frac{h_2}{\cos \alpha_2} - h_1\right]}$$

*in which:*

*g is 32.2 ft/s<sup>2</sup> or 9.81 m/s<sup>2</sup>,*

*h<sub>1</sub> is B/(tan $\alpha_1$  + tan $\beta_1$ ),*

*h<sub>2</sub> is B/(tan $\alpha_2$  + tan $\beta_2$ ) and*

*d<sub>2</sub> is h<sub>2</sub> (tan $\alpha_2$ )*

Figure 24.1  
Dynamic stability test

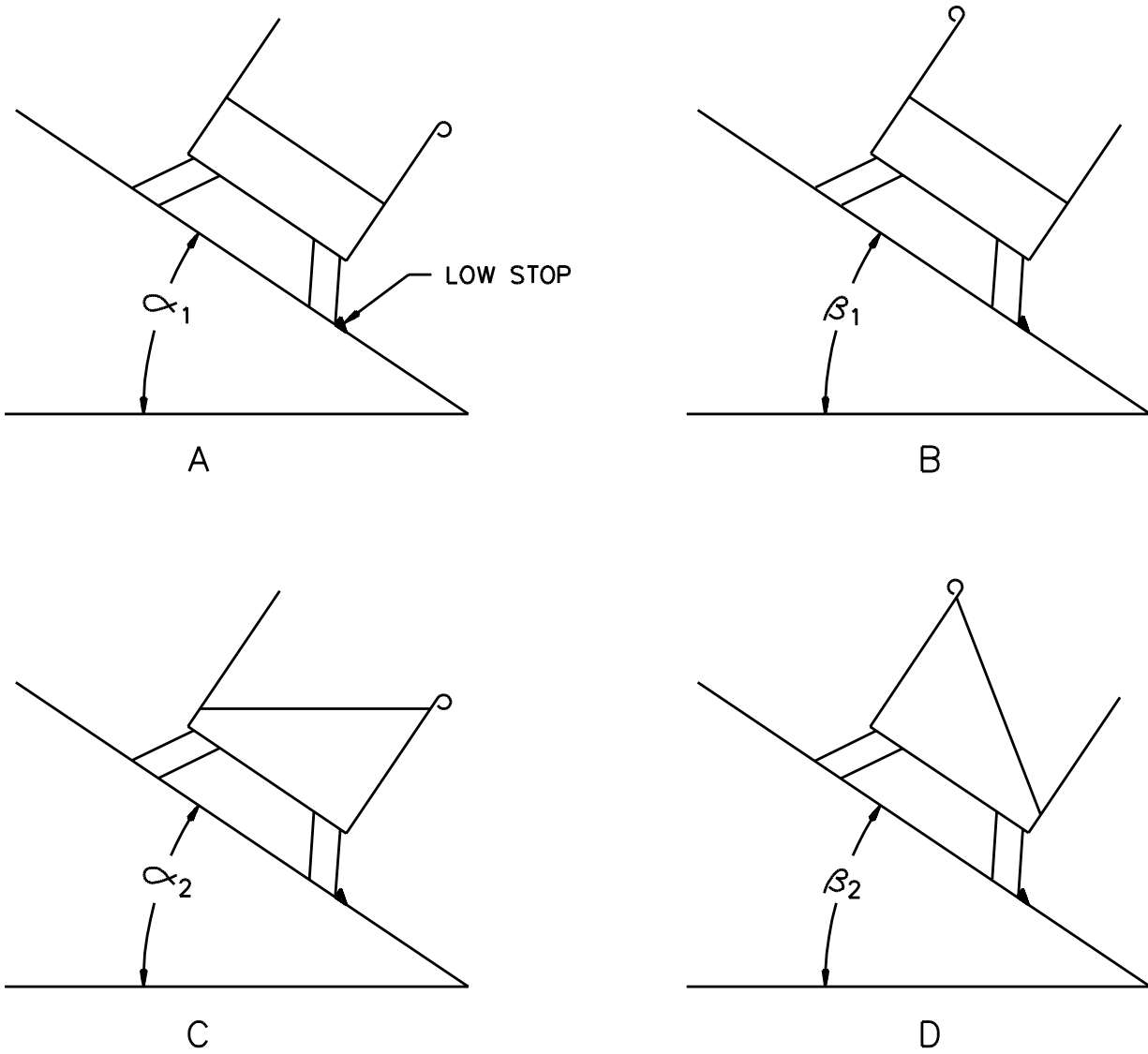

S3171

## PERFORMANCE

### 25 General

25.1 The performance of an appliance shall be investigated by subjecting the requisite number of samples to all the applicable tests as described in Sections 26 – 44. Insofar as practicable, the tests shall be conducted in the order in which they are presented here. Samples employed for leakage-current tests shall be first tested for leakage prior to employing the samples for other tests.

### 26 Power Input Test

26.1 The power input to an appliance shall not be more than 105 percent of its marked rating.

26.2 To determine whether an appliance complies with the requirement in 26.1, the power input is to be measured with the appliance at normal operating temperature under full-load conditions and while connected to a supply circuit adjusted to be the marked voltage rating. If an appliance employs a nonmetallic element (such as carbon), the power input is to be determined for a new element.

### 27 Leakage Current Test

27.1 The leakage current of a cord-connected appliance rated for a nominal 120-V or 240-V supply when tested in accordance with 27.3 – 27.7 shall not be more than:

- a) 0.5 mA for an ungrounded (2-wire) appliance,
- b) 0.5 mA for a grounded (3-wire) appliance that is easily carried or conveyed by hand, and
- c) 0.75 mA for a grounded (3-wire) permanently connected appliance, or a cord connected appliance that is intended to be fastened in place or located in a dedicated space and employing a standard attachment plug rated 20 A or less.

*Exception: The leakage current of an appliance incorporating a sheath type heating element, when measured in accordance with 27.3 – 27.7, shall not exceed 2.5 mA during the first 5 minutes after reaching the leakage current limit of 0.5 mA or 0.75 mA, as applicable, and at the end of this time, the leakage current shall be not more than the 0.5 mA or 0.75 mA limit as applicable – the leakage current is to be monitored during heat-up and cool-down.*

27.2 Leakage current refers to all currents, including capacitively coupled currents, which may be conveyed between exposed conductive surfaces of an appliance and ground or other exposed conductive surfaces of an appliance.

27.3 All exposed conductive surfaces are to be tested for leakage currents. The leakage currents from these surfaces are to be measured to the grounded supply conductor individually as well as collectively where simultaneously accessible and from one surface to another where simultaneously accessible. Parts are considered to be exposed surfaces unless guarded by an enclosure considered acceptable for protection against electric shock as defined in 6.1 – 6.14. Surfaces are considered to be simultaneously accessible when they can be readily contacted by one or both hands of a person at the same time. These measurements do not apply to terminals operating at voltages which do not present a risk of electric shock.

27.4 If a conductive surface other than metal is used for the enclosure or part of the enclosure, the leakage current is to be measured using a metal foil with an area of 10 by 20 cm in contact with the surface. Where the surface is less than 10 by 20 cm, the metal foil is to be the same size as the surface. The metal foil is not to remain in place long enough to affect the temperature of the appliance.

27.5 The measurement circuit for leakage current is to be as shown in Figure 27.1. The ideal measurement instruction is defined in items A – D. The meter which is actually used for a measurement need only indicate the same numerical value for a particular measurement as would the ideal instruments. The meter used need not have all the attributes of the idea instrument.

- a) The meter is to have an input impedance of 1500 ohms resistive shunted by a capacitance of 0.15  $\mu\text{F}$ .
- b) The meter is to indicate 1.11 times the average of the full-wave rectified composition waveform of voltage across the resistor or current through the resistor.
- c) Over a frequency range of 0 – 100 kHz, the measurement circuitry is to have a frequency response (ratio of indicated to actual value of current) that is equal to the ratio of impedance of a 1500 ohm resistor shunted by 0.15  $\mu\text{F}$  capacitor to 1500 ohms. At an indication of 0.5 mA, the measurement is to have an error of not more than 5 percent at 60 Hz.
- d) Unless the meter is being used to measure leakage from one part of an appliance to another, the meter is to be connected between the accessible parts and the grounded supply conductor.

**Figure 27.1**  
**Leakage-current measurement circuit**

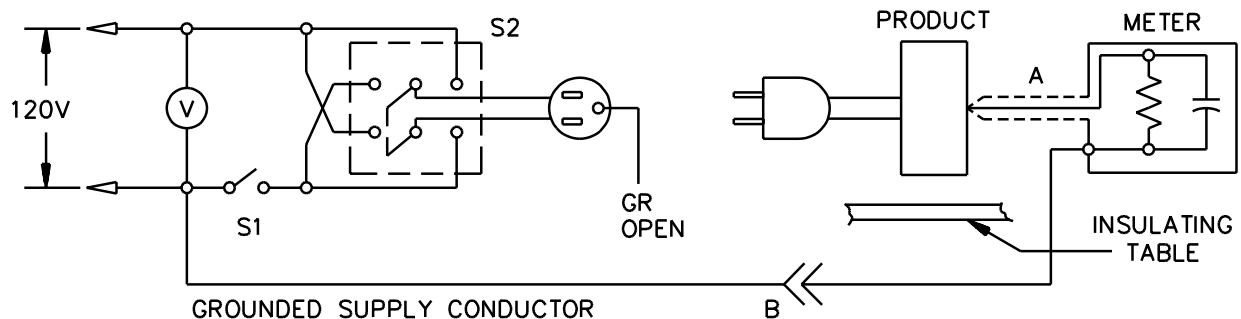

LC100G

**NOTE:**

A: Probe with shielded lead.

B: Separated and used as clip when measuring currents from one part of device to another

27.6 A sample of the appliance is to be tested for leakage current starting with the "as received" condition with all its switches and thermostats closed, but its grounding conductor, if any, open at the attachment plug. The "as received" condition being without prior energization, except as may occur as part of the production line testing. The supply voltages is to be 120- to 240V. The test sequence, with reference to the measuring circuit (Figure 27.1), is to be as follows:

- a) With switch S1 open, the appliance is to be connected to the measuring circuit. Leakage current is to be measured using both positions of switch S2.
- b) Switch S1 is then to be closed, energizing the appliance, and within a period of 5 seconds, the leakage current is to be measured using both positions of switch S2, and with the appliance operated at the maximum heat setting of controls.
- c) Leakage current is to be monitored until thermal stabilization under the maximum heat condition. Both positions of switch S2 are to be used. The equivalent of thermal stabilization is considered to be obtained as in the normal temperature test. If any thermostat does not cycle at the maximum heat setting, it is to be adjusted until it does cycle before the final measurements at thermal stabilization are taken. Measurements are to be made with the thermostat, if any, open and closed. Upon evidence of stabilizing readings, monitoring periods may be increased.
- d) If the appliance employs a single pole switch, monitoring of leakage current is to continue until the leakage current stabilizes or decreases after the appliance is turned off.

27.7 Normally a sample will be carried through the complete leakage current test program as covered by 27.6 without interruption for other tests. With the concurrence of those concerned, the leakage current tests may be interrupted for the purpose of conducting other non-destructive tests.

## **28 Operational Tests**

28.1 Operation of an appliance while simulating anticipated conditions of use shall not increase the risk of fire, electric shock, or injury to persons.

28.2 In conducting the test, the conditions mentioned in the manufacturer's instructions, including cleaning, maintenance, and the use of accessories may be included or omitted so as to simulate reasonably foreseeable actions of the user.

## **29 Calibration Tests of Probe-Type Temperature Controls**

29.1 The maximum temperature at the center of the underside of the appliance cooking surface shall not be higher than 300°C (572°F) either before or after a probe-type control is dropped in accordance with 29.2. The average of the maximum and minimum temperatures shall not be higher than 260°C (500°F) either before or after the dropping.

29.2 Six samples of each control are to be calibrated, and the maximum or minimum temperature in any case is to be the average of at least five temperature readings taken during the cycling of the control after a stabilized cycling pattern has been established. After the initial calibration, each control, while still heated, is to be dropped five times from a height of 3 ft (0.91 m) onto a hardwood surface, following which the control is to be recalibrated.

29.3 The normal temperature test is to be conducted:

- a) Employing the sample probe-type control that results in the highest center temperature before the drop test, and also, employing the sample probe-type control that results in the highest center temperature after the drop test, if that temperature is higher than the highest temperature obtained before the drop test, or
- b) Employing the sample probe-type control that results in the highest center temperature after the drop test, if that temperature is higher than the highest temperature obtained before the drop test. However, if the highest center temperature is obtained before the drop test, a sample probe-type control that is calibrated to provide the highest center temperature is to be employed.

## 29A Mechanical Abuse

Section 29A added June 6, 2001

29A.1 A detachable power-supply cord employing a magnetic appliance coupler that complies with the requirements of UL 498 or UL 817 need not comply with 29A.2 and 29A.3. A detachable power-supply cord set employing a magnetic appliance coupler and manufactured specifically for use with a deep-fat fryer, cooker/fryer or fondue need not comply with the Mechanical Endurance Test in UL 498 or UL 817 (though it must comply with all other applicable requirements in UL 498 or UL 817) provided that it complies with 29A.2 and 29A.3.

29A.2 Each of six representative detachable power-supply cords employing a magnetic appliance coupler used in deep fat fryers, cooker/fryers and fondues is to be placed in a full-draft circulating-air oven for 24 hours at 10°C (18°F) higher than the maximum temperature on the magnetic appliance coupler, as measured under normal operating conditions, but not less than 70°C (158°F). After the conditioning and allowing to cool to room temperature, each magnetic appliance coupler is to be examined for cracking, shrinkage or warping to the extent that the magnetic appliance coupler remains fully functional.

29A.3 Each of the representative power-supply cords is to be bundled with the coupler under the cord and then allowed to drop as an assembly freely from a height of 3 feet (0.91 m) onto a hardwood surface (consisting of a layer of nominally 1-inch thick tongue-and-groove oak flooring mounted on two layers of 3/4-inch plywood) for a total of 125 drops, such that the coupler is impacted at various locations. Upon completion of the first 50 drops, each representative power-supply cord shall:

- a) Be fully functional, and
- b) Not crack or break to the extent that it becomes unfit for use or exposes live parts to unintentional contact, and
- c) Not experience any displacement of current-carrying parts or loosening of the cord at the wiring terminals.

Following the above, each of the representative power-supply cords is to be dropped an additional 75 times. Upon completion of the 125 drops, the representative power-supply cords shall be in compliance with Items (b) and (c) above.

## 30 Normal Temperature Test

### 30.1 General

30.1.1 An appliance, when tested under the conditions described in 30.1.4 – 30.2.5.3, shall comply with all three of the following conditions:

- a) The appliance shall not attain at any point a temperature that would constitute a risk of fire or damage any materials employed in the appliance.
- b) At any time during the test – other than as indicated in 30.1.2 and 30.1.3 – temperature rises at specific points shall not be greater than indicated in Table 30.1.
- c) The appliance shall comply with the requirement in 6.1.

30.1.2 Initial temperature transients may be in excess of the temperature limits specified in Table 30.1 and 30.1.3 if the duration and extent of the excursion do not result in risk of fire or electric shock and do not unduly shorten the life of the appliance.

30.1.3 Temperatures are to be measured during preheat modes. Temperature rises not exceeding those specified in Table 30.1 by more than 20 percent are acceptable.

30.1.4 All values in Table 30.1 are based on an assumed ambient (room) temperature of 25°C (77°F), but a test may be conducted at any ambient temperature within the range of 10 – 40°C (50 – 104°F). However, if the operation of an automatic thermal control during the test limits the temperatures under observation, no temperature higher than 25°C (77°F) plus the specified maximum rise is acceptable.

30.1.5 In an appliance that can hold an appreciable quantity of oil, fat, or grease during the cooking operation, the maximum and average temperatures measured at the center of the cooking surface shall not be higher than 300°C (572°F), and 260°C (500°F), respectively. These temperatures are to be measured after a stabilized cycling pattern has been established. The temperature at any point on the cooking surface shall not exceed 390°C (734°F) at any time during the test.

*Exception: Corn popping appliances shall comply with 30.2.5.1 – 30.2.5.3.*

No Text on This Page



30.1.6 A gasket that is depended upon to prevent the entrance of water into an appliance during cleaning shall not become hard or brittle, shall not crack, and shall show no other signs of deterioration as a result of an accelerated-aging test in which the gasket is subjected to elevated temperatures. See 31.2.4.

30.1.7 The temperature to which the gasket is subjected during the test, as well as the duration of the test, is to be determined in accordance with the material of the gasket, the temperature to which it is subjected during operation, and other conditions of the particular application. Normally the appliance is to be operated dry and for a period of 240 hours.

30.1.8 Following the accelerated aging, the sample is to be immersed, tested, and examined for the entrance of water.

30.1.9 Temperatures are to be measured by thermocouples consisting of wires no larger than No. 24 AWG (0.21 mm<sup>2</sup>) and no smaller than No. 30 AWG (0.05 mm<sup>2</sup>), except that a coil temperature may be determined by the change-of-resistance method if the coil is inaccessible for mounting thermocouples. When thermocouples are used in determining temperatures in electrical equipment, thermocouples consisting of No. 30 AWG iron and constantan wire and a potentiometer-type instrument, are to be used whenever referee temperature measurements by thermocouples are necessary.

30.1.10 For tests that are to be continued until constant temperatures are attained, thermal equilibrium is to be considered to exist only if three successive readings indicate no change when taken at the conclusion of each of three consecutive equal intervals of time, the duration of each interval being whichever of the following is longer:

- a) 5 minutes, or
- b) 10 percent of the total test time elapsed previous to the start of the first interval.

The thermocouple wire is to conform with the requirements specified in the Initial Calibration Tolerances for Thermocouples table in Temperature-Measurement Thermocouples, ANSI/ISA MC96.1-1982. The thermocouples and related instruments are to be accurate and calibrated in accordance with good laboratory practice.

30.1.10 revised December 11, 2000

30.1.11 A thermocouple junction and adjacent thermocouple lead wire are to be securely held in good thermal contact with the surface of the material whose temperature is being measured. In most cases, good thermal contact with result from securely taping or cementing the thermocouple in place but, if a metal surface is involved, brazing or soldering the thermocouple to the metal may be necessary.

30.1.12 To determine whether an appliance complies with the requirements in 30.1.1, the appliance is to be operated continuously until constant temperatures have been reached. The test voltage is to be the marked voltage rating or the test voltage specified is to be increased, if necessary, to cause the wattage input to the appliance to be equal to the wattage rating marked on the appliance.

30.1.13 In conducting a test to determine whether an appliance complies with the temperature requirements, it is to be mounted or supported as in service and tested under conditions approximating those of normal operation, except as otherwise noted. Temperatures are to be observed on nearby surfaces, on the supporting surface, at points of support, on attachment plugs, and at other points as may be necessary.

**Table 30.1**  
**Maximum acceptable temperature rises**

Material and component parts		°C	°F
1.	Fiber used as electrical insulation or as cord bushings	65	117
2.	Wood or other combustible material which is a part of a heating appliance	65	117
3.	Cotton or rayon braid of a flexible cord	65 <sup>a</sup>	117 <sup>a</sup>
4.	Phenolic composition used as electrical insulation or where deterioration would result in a risk of fire, electrical shock or personal injury <sup>b</sup>	125	225
5.	Points on surface supporting an appliance and on adjacent surfaces of test corner	100	180
6.	Points on adjacent surface of test corner	100	180
7.	Flatiron or appliance plug	175	315
8.	Insulated wire or cord	25°C (77°F) less than its temperature rating <sup>c</sup>	
9.	Sealing compound	d	d
10.	A. Copper, tinned or bare strands: a) less than 0.015 inch (.38 mm) in diameter b) 0.015 inch diameter and larger B. Nickel, gold or silver platings or combinations of those platings, over copper conductors	125  175 225	225  315 405
11.	Termination of copper conductor and pressure terminal connector without being nickel-coated or otherwise acceptably protected.	125	225

<sup>a</sup> Inside an appliance, the braid of a heater cord may be subjected to a greater rise if the asbestos insulation is held in place by other acceptable means.

<sup>b</sup> The limitation on phenolic composition does not apply to a compound which has been investigated and found to have special heat-resistant properties.

<sup>c</sup> Inside an appliance, the temperature rise on a wire or cord may be greater than the specified maximum rise, provided that the insulation on each individual conductor is protected by supplementary insulation (such as braid, wrap, tape or close-fitting tubing) which is entirely acceptable for the temperature and the type of insulation involved.

<sup>d</sup> Unless a thermosetting material, the maximum sealing compound temperature, when corrected to a 25°C (77°F) ambient temperature is 15°C less than the softening point of the compound as determined by the Test Method for Softening Point by Ring-and-Ball Apparatus, ASTM E28-92.

30.1.14 Unless otherwise indicated in the description of the test for a specific appliance, a cord-connected appliance is to be supported on two layers of white tissue paper on a softwood surface.

30.1.15 An appliance is to be tested in a test corner with the appliance located 4 inches (100 mm) away from the side and rear walls of the test corner. The 4 inch (100 mm) spacing is to be measured from the outer most extremity of the appliance. The test corner is to consist of dull black-painted fir plywood not less than 3/8 inch (9.5 mm) thick, having such width and height that the walls extend not less than 2 ft (0.61 m) beyond the physical limits of the appliance. The vertical walls are to meet at a right angle.

30.1.16 Thermocouples are to be mounted on wood surfaces using the method illustrated in Figure 30.1 or the equivalent. Starting in the corner, thermocouples are to be placed every 3 inches (76 mm) on each surface (Figure 30.2) so that a minimum area of 18 inches by 18 inches (460 mm by 460 mm) is covered by the thermocouples on each surface.

**Figure 30.1**  
**Method of mounting thermocouple**

Figure 30.1 revised December 24, 1998

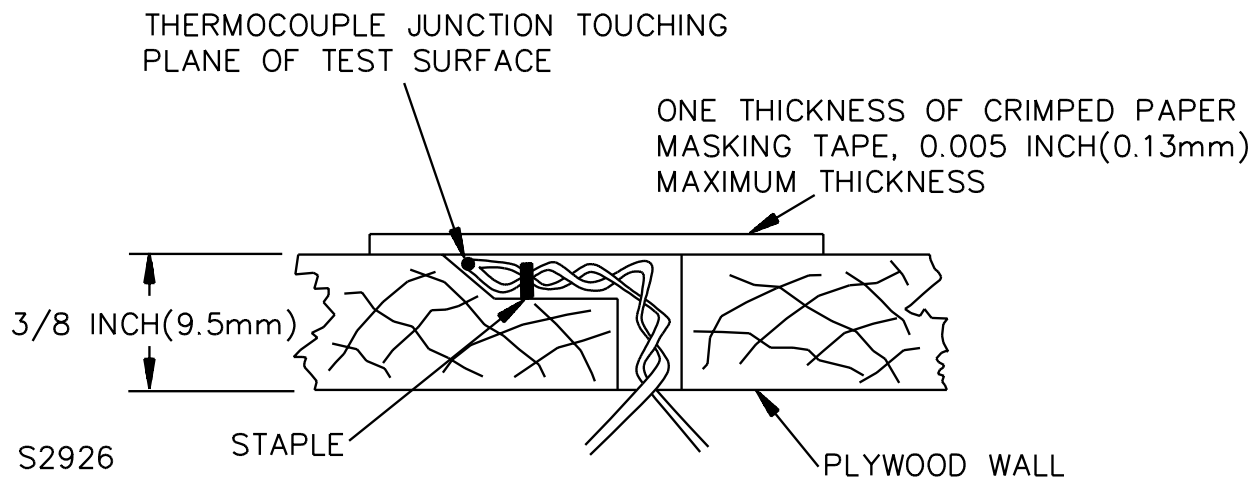
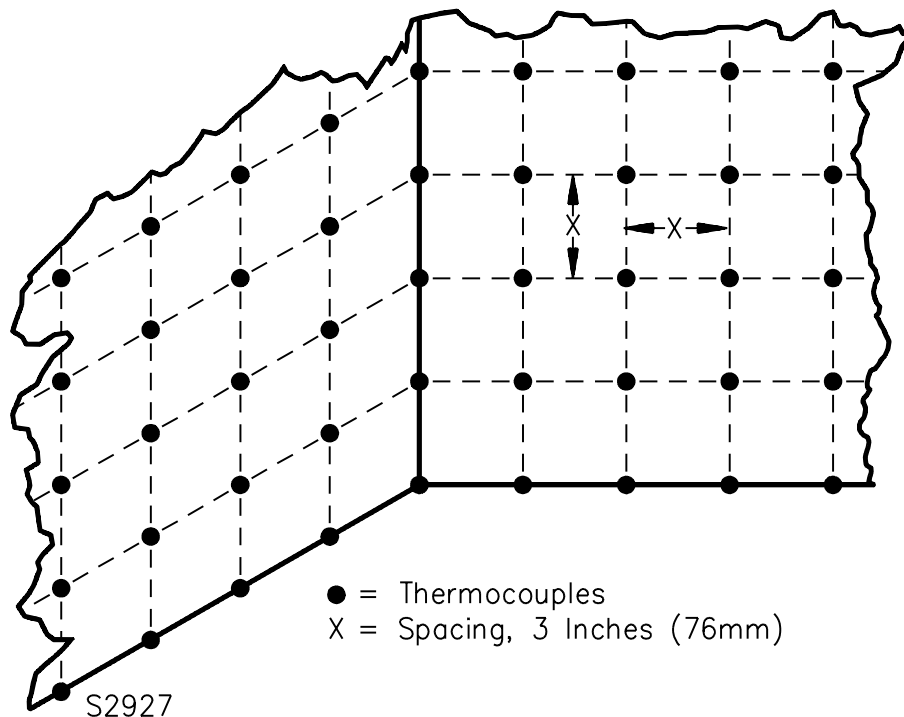

Figure 30.2  
Thermocouple spacings



30.1.17 An automatic temperature-regulating or -limiting control or other protective device provided as a part of an appliance is to be shunted out of the circuit, unless the control has been shown in accordance with Table 42.1 to be rugged, reliable, and unlikely to be defeated by the user. The control is considered to be unlikely to be defeated if tools are required to gain access to the control, or a positive stop is incorporated in the control.

30.1.18 During the normal temperature test, a temperature-limiting device provided for overheating protection shall not operate.

30.1.19 If the design of a heating appliance is such that cooking or heating of a liquid is a determining factor in the temperature attained, the intended duty of the appliance is to be taken into consideration. In determining whether an appliance complies with the requirements in 30.1.1, actual service conditions or an approximation thereof are to be employed. Unless otherwise specifically indicated below;

- a) If the appliance is controlled by an adjustable thermostat, the thermostat is to be set to give maximum temperatures, and
- b) If the appliance is controlled by a nonadjustable thermostat, it is to be allowed to operate at whatever temperature the thermostat permits. In each case, operation is to be continued until temperatures are stabilized.

30.1.20 An appliance such as a waffle or sandwich maker which may be either open or closed in actual service, is to be tested both open and closed to determine which condition produces the higher operating temperature.

30.1.21 An appliance that is required to be preheated as part of the temperature or abnormal tests is to be preheated as follows:

- a) In accordance with the manufacturer's instructions marked in a readily visible location on the appliance, or
- b) If not marked, the appliance is to be operated for 15 minutes at the temperature setting specified for the cooking portion of the test.

*Exception: An appliance is not to be preheated if the manufacturer's instructions specifically state that preheating of the appliance is not necessary. See 51.1.*

30.1.22 Whenever hamburger is mentioned in connection with either a temperature or an abnormal test, each hamburger is to consist of a mixture of 75 percent lean beef and 25 percent suet by weight ground together twice in succession. A hamburger is to be 3/4 inch (19 mm) thick and have a 4 inch (102 mm) diameter before cooking. The initial internal hamburger temperature is to be 4.4°C (40°F). A hamburger is considered well done when a central internal temperature of 74°C (165°F) is attained on a centrally located hamburger.

No Text on This Page

## 30.2 Specific test conditions

### 30.2.1 General

30.2.1.1 For most of the common types of appliances, standardized normal conditions for the temperature tests are given in 30.2.2.1 – 30.2.10.1.

### 30.2.2 Deep-fat fryers and cooker/fryers

30.2.2.1 The fryer is to be filled with pure cold pressed peanut oil to the level indicated on the appliance or in the instruction manual. The fryer is to be preheated in accordance with 30.1.21 and then 3 batches of french fries are to be cooked, according to the manufacturer's instructions. Each batch is to be cooked to a good brown color. A good brown color is to be determined by use of the french fries color chart in Appendix B. Unloading and loading between batches is to be accomplished in 15 – 30 seconds. Each batch of french fries is to consist of the maximum load recommended. The french fries are to be made using fresh standard baking potatoes cut 3/8 – 1/2 inch (9.6 – 12.7 mm) on a side and are to be of any convenient length. See 30.1.5 for the cooking surface temperature test.

### 30.2.3 Waffle bakers and sandwich grills

30.2.3.1 A waffle baker, or a combination unit, is to be preheated in accordance with 30.1.21 and then operated for 10 baking operations. Unloading and loading between operations is accomplished in 15 – 30 seconds. An adjustable temperature control is to be set at the manufacturer's recommended setting, if marked in a readily visible location, or, if not marked, at the maximum temperature setting. The waffles are to be baked to a good brown color. A good brown color is to be determined by the use of the waffle color chart in Appendix B. The batter is to be a commercially prepared mix.

30.2.3.2 A sandwich grill, or a combination unit, is to be preheated and then operated toasting a maximum of 10 sandwiches. An adjustable temperature control is to be set at the manufacturer's recommended setting, if marked in a readily visible location, or, if not marked, at the maximum temperature setting. For each toasting operation, the lower grill is to be filled to capacity for as many cycles as possible and the remainder of the 10 sandwiches used for the last cycle and the grill is to be closed. Unloading and loading between operations is to be accomplished in 15 – 30 seconds. Each sandwich is to consist of two slices of white bread, weighing approximately 25 g, with 2 slices of cheese [commercially available 1/2 oz (14 g) per slice processed cheese] between the bread slices. Those sides in contact with the grills are to be coated with butter. The test is to be repeated with the grills open and using only one grill to toast sandwiches. The sandwiches are to be toasted on both sides to a good brown color. A good brown color is to be determined by the use of the toast color chart in Appendix B.

*Exception: The appliance is to be operated in the open position unless the manufacturer's instructions indicate the appliance is only to be operated in the closed position.*

### 30.2.4 Skillets and woks

30.2.4.1 A skillet or a wok is to be operated as set forth in 30.2.4.2. However, the method indicated in 30.2.4.3 may be used as an alternate if agreeable to those concerned.

30.2.4.2 A skillet is to be preheated according to 30.1.21 and then operated baking potatoes. The potatoes are to occupy 75 – 80 percent of the cooking surface. The temperature control setting is to be adjusted to maintain a cooking temperature of 204°C (400°F) or the setting marked in a readily visible location on the product, but not less than 177°C (350°F) in any case. The potatoes are to be standard baking potatoes each weighing between 3/8 – 5/8 lb (0.83 – 1.38 kg). The test is to be terminated when the internal center temperature of a centrally located potato is 99°C (210°F).

30.2.4.3 The appliance is to be operated continuously with the thermostat set at the maximum setting until thermal equilibrium is attained. The appliance is to be filled to a depth of 1/2 inch (13 mm) with pure cold pressed peanut oil as measured at the center of the pan. See 30.1.5 for the cooking surface temperature test.

### 30.2.5 Corn poppers

30.2.5.1 Two tests shall be made. The temperature at any point on the cooking surface shall not exceed 370°C (698°F) at any time during the tests. For these tests, thermocouples shall be soldered, peened, or welded into the cooking surface.

30.2.5.2 For the first test, the appliance is to be operated dry and empty, and with the cover in place. During this test only the cooking surface temperature is to be measured.

30.2.5.3 For the second test, the manufacturer's recommended amount of oil and popping corn shall be placed in the appliance. The oil used in this test shall be pure peanut oil. The appliance shall be operated with the cover in place until the batch of ingredients is thoroughly popped. The appliance shall be immediately emptied of the corn and oil mixture and immediately refilled with fresh ingredients. The test shall be repeated through as many operations needed to attain thermal equilibrium.

### 30.2.6 Hamburger makers

30.2.6.1 The appliance is to be preheated according to 30.1.21 and then operated continuously cooking 10 hamburgers or 5 loads of hamburgers, whichever is more. The hamburgers are to be cooked until well done following the instruction manual directions. Grease from the hamburgers is to be drained from the appliance between cycles. 15 seconds are to be allowed for draining the grease.

### 30.2.7 Donut makers

30.2.7.1 The appliance is to be preheated according to 30.1.21 and then operated continuously making 20 donuts or 5 loads of donuts, whichever is more. The batter is to be prepared in accordance with the instruction manual recipe. Any thermostat is to be set at the highest setting recommended in the manufacturer's instructions. The unload/load time is to be between 15 and 30 seconds.

### 30.2.8 Griddles

30.2.8.1 The appliance is to be preheated according to 30.1.21 and then operated continuously cooking 2 loads of hamburgers. Each load is to fill 75 percent of the cooking surface area and is to be cooked until well done. The thermostat is to be set in accordance with the instructions marked in a readily visible location on the product, or, if not marked, at the maximum setting. Grease from the hamburgers is to be drained from the appliance between cycles. 15 seconds are to be allowed for draining the grease.



### 30.2.9 Crepe makers

30.2.9.1 The appliance is to be preheated in accordance with 30.1.21 and then operated continuously cooking 10 crepes, as quickly as practical. A commercially prepared mix, or a mix made following the instructions, is to be used. Any thermostat is to be set at the maximum setting.

### 30.2.10 Fondues

30.2.10.1 The appliance is to be operated continuously with the thermostat set at the maximum setting until thermal equilibrium is obtained. The fondue is to be filled with pure cold pressed peanut oil to the level indicated in the instruction manual. See 30.1.5 for the cooking surface temperature test.

## 31 Insulation Resistance and Leakage Current Tests as a Result of Moisture

### 31.1 General

31.1.1 An appliance employing insulation material likely to be affected adversely by moisture under condition of normal use shall be conditioned for 48 hours in moist air having a relative humidity of  $88 \pm 2$  percent at a temperature of  $32.0 \pm 2.0^\circ\text{C}$  ( $89.6 \pm 3.6^\circ\text{F}$ ). After the conditioning, the appliance shall comply with the requirement in 27.1 in a repeat leakage current test, except that the test shall be discontinued when leakage current stabilizes.

31.1.2 An additional sample of the appliance shall be tested as follows, if glass-fiber sleeving is used as electrical insulation in a rope heater assembly. The appliance shall be operated for 96 continuous hours under the condition resulting in the maximum temperature on the sleeving, as determined from the normal temperature test, following which it shall be conditioned for 48 hours in moist air having a relative humidity of  $88 \pm 2$  percent at a temperature of  $32.0 \pm 2.0^\circ\text{C}$  ( $89.6 \pm 3.6^\circ\text{F}$ ). After the conditioning, the appliance shall comply with the requirement in 27.1 in a repeat leakage current test, except that the test shall be discontinued when the leakage current stabilizes. Following the leakage current test, the appliance shall also comply with the dielectric voltage-withstand test requirement of 32.1.

### 31.2 Immersion

31.2.1 Except as noted in 31.2.2, an appliance that is likely to be immersed in water for cleaning shall show a leakage current of no more than 0.5 mA and shall be capable of withstanding a potential of 1000 V when tested in accordance with 31.2.2 – 31.2.5. The test shall not result in the entrance of water into the interior of the appliance such that the water might come into contact with uninsulated live parts.

31.2.2 An appliance marked to indicate that it is not intended for immersion need not comply with the requirements in 31.2.1. See 48.8.

31.2.3 Three samples of the appliance are to be heated as described in 31.2.5 and are then to be immersed immediately in water at a temperature of  $10 - 25^\circ\text{C}$  ( $50 - 77^\circ\text{F}$ ). The immersion is to be complete unless the appliance is marked to indicate that it is intended for partial immersion only (see 48.8), in which case each appliance is to be immersed only to the extent indicated. After 1 hour of immersion, the samples are to be removed from the water, dried with a soft cloth to remove all surface moisture, including surface moisture from terminal pins, and the samples are to be tested for leakage current.

31.2.4 The entire procedure of immersion and leakage current measurement is to be repeated four times, immediately following which each sample is to be subjected to a 1000-V dielectric voltage-withstand test as described in 32.1. The three samples are to be used for aging tests, and are required to comply with the requirements in 30.1.6 – 30.1.8. If there is an air cavity having electrical components, the three samples are to be disassembled and the internal parts visually examined for the presence of water (31.2.1). See Table 31.1.

31.2.5 An appliance is to be heated for the immersion test by operating it dry, with the thermostat at the highest setting, until the thermostat automatically switches to the low or off position.

**Table 31.1**  
**Immersion tests<sup>a</sup>**

All appliances likely to be immersed			
	Conditioning for tests		
	Sample No. 1	Sample No. 2	Sample No. 3
First 5 Cycles	Dry initially and throughout conditioning Immerse one hour Dry with cloth Leakage Current Test		
After 5th Cycle	Dielectric Voltage-Withstand Test Operate 240 hours Cool to room temperature Reheat as for Normal Temperature Test Immerse for one hour Leakage Current Test Dielectric Voltage-Withstand Test		

<sup>a</sup> If there is an air cavity housing electrical components in the appliance, disassemble and examine for water.

### 31.3 Cool-Down Leakage Current

31.3.1 When tested in accordance with the procedure outlined in 27.3 – 27.6(b), as modified by 31.3.5, an immersible appliance shall not show evidence of heat-up or cool-down leakage currents greater than those set forth in Table 31.2 under the test conditions outlined in 31.3.2 – 31.3.5.

31.3.2 The set of five samples is to be selected from the end of the production line just prior to packaging and subjected to the heat-up and cool-down leakage current test (see 31.3.5) under the humidity conditions existing at that time. The test results are to be retained with the samples for further investigation.

**Table 31.2**  
**Maximum acceptable leakage current in milliamperes for immersible appliances**

Conditioning	Time period				
	S1 open	S1 closed			S1 close-control open
		0 – 5 sec	5 sec – 10 min	At 10 min	Cool-down period
Test conducted at the end of the production line	0.5	0.5	0.5	0.5	0.5
As received	0.5	0.5	2.5	0.5	2.5
After 56 days in humidity chamber	0.5	0.5	5.0	0.5	5.0

31.3.3 The set of five samples, as received, shall be subjected to heat-up and cool-down leakage current test to determine that the leakage current characteristics have not been affected during transit prior to insertion in the humidity cabinet.

31.3.4 The set of five samples is then to be placed in a humidity cabinet operating at  $88 \pm 2$  percent relative humidity and at a temperature of  $32.0 \pm 2.0^\circ\text{C}$  ( $89.6 \pm 3.6^\circ\text{F}$ ) for a period of 56 days. It is standard laboratory practice to adjust the chamber, having laboratory control accuracy, as close as possible to 90 percent relative humidity without exceeding 90 percent relative humidity. At the end of the 56 day conditioning period, the five samples shall be removed from the humidity cabinet, and subjected to the heat-up and cool-down leakage current test.

31.3.5 The heat-up and cool-down leakage current test is performed by energizing the immersible appliance for 10 minutes at the highest thermostat setting. The thermostat shall then be turned either to the "off" position (for a single-pole control), or the lowest temperature setting permitting single-pole operation (for a double-pole control). The values of leakage current are to be continuously observed until the temperature at the center of the appliance cooking surface is less than  $90^\circ\text{C}$  and the observed leakage current is decreasing.

## 32 Dielectric Voltage-Withstand Test

32.1 An appliance shall be capable of withstanding for 1 minute without an indication of unacceptable performance, the application of a potential applied between live parts and accessible metal parts. The appliance is to be at its maximum normal operating temperature. The test potential shall be 1000 V.

32.2 With respect to 32.1, an appliance having an enclosure constructed partly or totally of insulating material is to have accessible surfaces of the material closely wrapped in metal foil. The test potential is to be applied between live parts and the foil.

32.3 With respect to 32.1 and 32.2, a part is considered to be accessible if it can be contacted by the probe illustrated in Figure 6.2 when applied in all possible articulate positions, with and without the parts referenced in 6.14 in place.

32.4 To determine whether an appliance complies with the requirements in 32.1, the test potential is to be applied as described in 32.6, by means of test equipment having the characteristics outlined in 32.5.

32.5 The test equipment for conducting the dielectric voltage-withstand test is to have the following features and characteristics:

- a) A means for indicating the test voltage that is being applied to the appliance under test. This may be accomplished by sensing the voltage at the test leads or by an equivalent means.
- b) An output voltage that
  - 1) Has a sinusoidal waveform,
  - 2) Has a frequency that is within the range of 40 – 70 Hz, and
  - 3) Has a peak value of the waveform that is not less than 1.3 and not more than 1.5 times the root-mean-square value.
- c) A sensitivity of the test equipment that is such that when a resistor of 120,000 ohms is connected across the output, the test equipment does not indicate unacceptable performance for any output voltage less than the specified test voltage, and the test equipment does indicate unacceptable performance for any output voltage equal to or greater than the specified test value. The resistance of the calibrating resistor is to be adjusted as close to 120,000 ohms as instrument accuracy can provide, but never more than 120,000 ohms.

*Exception: The sensitivity of the test equipment may be increased, a higher value of calibrating resistance may be used, if agreeable to those concerned.*

32.6 The method of applying the test voltage to the appliance is to be such that there are not any transient voltages that result in the instantaneous voltage applied to the appliance exceeding 105 percent of the peak value of the specified test voltage. The applied potential is to be increased from zero at a substantially uniform rate so as to arrive at the specified test potential in approximately 5 seconds, and then is to be maintained at the test potential for 1 minute. Manual control of the rate of rise may be used.

### 33 Strain Relief Test

33.1 The strain-relief means provided on an attached flexible cord, when tested in accordance with 33.2, shall be capable of withstanding for 1 minute, without displacement, a pull of 35 lbf (156 N) applied to the cord, with the connections within the appliance disconnected.

33.2 The specified force is to be applied to the cord and so supported by the appliance that the strain-relief means will be stressed from any angle that the construction of the appliance permits. The strain relief is not acceptable if, at the point of disconnection of the conductors, there is sufficient movement of the cord to indicate that stress on the connections would have resulted.

#### 33A Push-Back Relief Test

\*Section 33A added December 24, 1998\*

33A.1 To determine compliance with 9.2.3, a product shall be tested in accordance with 33A.2 without occurrence of any of the following conditions:

- a) Subjecting the supply cord or lead to mechanical damage;
- b) Exposing the supply cord or lead to a temperature higher than that for which it is rated;
- c) Reducing spacings (such as to a metal strain-relief clamp) below the minimum required values;  
or
- d) Damaging internal connections or components.

33A.2 The supply cord or lead is to be held 1 inch (25.4 mm) from the point where the cord or lead emerges from the product and is then to be pushed back into the product. The cord or lead is to be pushed back into the product in 1 inch (25.4 mm) increments until the cord buckles or the force to push the cord into the product exceeds 6 pounds-force (26.7 N). The supply cord or lead within the product is to be manipulated to determine compliance with 9.2.3.

### 34 Metal Enclosure Impact Test

34.1 A metal enclosure part shall comply with the tests outlined in 34.2 – 34.5. For polymeric enclosure parts, see the Standard for Polymeric Materials – Use in Electrical Equipment Evaluations, UL 746C.

34.2 A metal enclosure part shall withstand the ball impact, with the appliance restrained, as described in 34.3 without occurrence of any one of the following conditions:

- a) Making live parts accessible to contact with the articulate probe; see 6.11 and 6.12.
- b) Producing any other condition that results in damage of the enclosure so as to adversely affect the function of any safety or constructional feature; such as thermostats, overload-protective devices, or strain relief.
- c) Producing other conditions so that the appliance does not comply with the dielectric voltage-withstand requirements in Dielectric Voltage-Withstand Test, Section 32, after being subjected to the impact.

34.3 Each of three samples of the appliance is to be subjected to one impact. This impact is to be imparted by dropping or swinging a 2 inch (50.8 mm) diameter steel sphere, weighing 1.18 lb (0.535 kg) from a height that will produce an impact of 1.5 lbf (2.03 N·m). The sample is to be rigidly supported and the impact is to be made perpendicular to the most vulnerable spots on the appliance enclosure that are exposed to a blow during intended use. A different spot on the enclosure is to be selected for each impact. Refer to Figure 34.2 with respect to the ball drop impact test and to Figure 34.3 for the ball pendulum impact test.

*Exception: If the manufacturer elects, fewer than three samples may be used for the test in accordance with Figure 34.1, wherein each series consists of one impact. The overall performance is acceptable upon completion of any one of the procedures represented in Figure 34.1.*

**Figure 34.1  
Procedure for impact test**

Series Number	Sample Number											
	1	2	3	1	2	3	1	2	3	1	2	3
1	↓ A	N	N	↓ A	N	N	↓ A	N	N	↓ A	N	N
2	↓ A	N	N	↓ A	N	N	↓ U	↓ A	N	↓ U	↓ A	N
3	↓ A	N	N	↓ U	↓ A	N	↓ A	N		↓ U	↓ A	

Arrows indicate sequence of test procedure

A – Acceptable results from drop

U – Unacceptable results from drop

N – No test necessary

SA1162

**Figure 34.2  
Ball drop impact test**

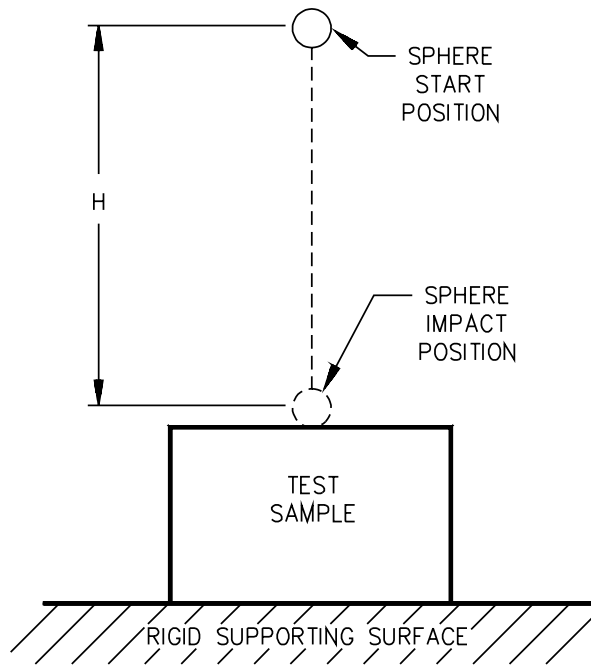

IP120

No Text on This Page



**Figure 34.3**  
**Ball pendulum impact test**

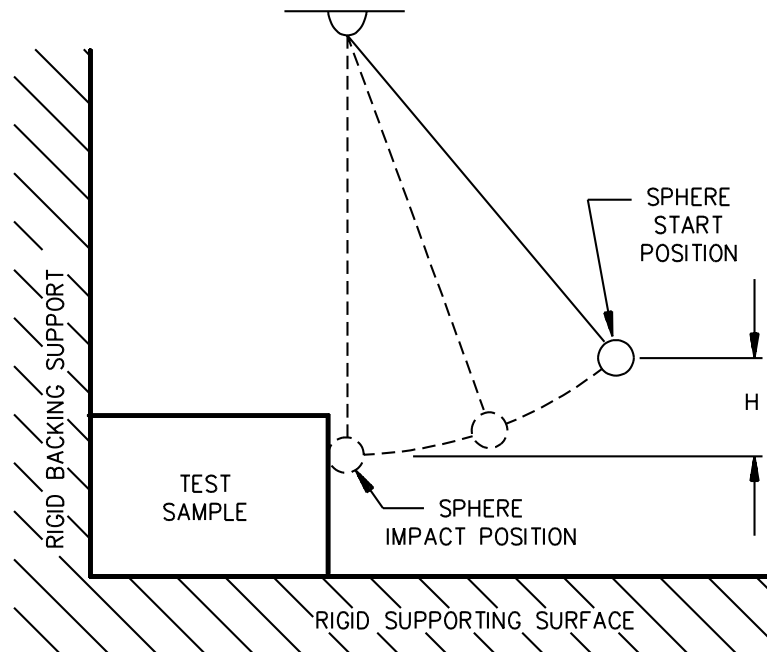

IP 160

34.4 With reference to Figures 34.2 and 34.3, the "H" designation represents the vertical distance the sphere must travel to produce the desired impact. For the pendulum impact, the sphere is to contact the test sample when the string is in the vertical position. The supporting surface is to be as described in 34.5. The backing surface for the pendulum impact is to consist of 3/4 inch (18 mm) plywood over a rigid surface of concrete or an equivalent nonresilient backing surface may be used.

34.5 The supporting surface mentioned in 34.4 is to consist of a layer of tongue-and-groove oak flooring mounted on two layers of 3/4 inch (18 mm) thick plywood. The oak flooring is to be nominally 3/4 by 2-1/4 inch (18 by 57 mm). The assembly is to rest on a concrete floor or an equivalent nonresilient surface.

### 35 Deep Fat Fryer, Cooker/Fryer, and Fondue Cycling Test

35.1 A handle feet, or combination handle/feet assembly of a deep fat fryer, cooker/fryer, fondue appliance, and basket handles shall be subjected to the test outlined in 35.2 without:

- a) Any loosening of the fastening means that results in loss of pan or basket control or
- b) Signs of deterioration of the material. In addition, there shall be no accumulation of oil in the compartment housing the heating element.

35.2 One sample of a deep-fat fryer, cooker/fryer, or fondue appliance with basket is to be filled with pure cold pressed peanut oil to the level indicated on the appliance or in the instruction manual. The deep-fat fryer, cooker/fryer, or fondue appliance is to be subjected to 100 cycles of operation. Each cycle is to consist of 30 minutes heating followed by 60 minutes cooling. During every 5th cycle, the appliance is to be operated in the cooking mode as described in Normal Temperature Test, Section 30. At the completion of every 5 cycles the appliance is to be drained and allowed to cool to the ambient room temperature.

*Exception: Supplemental cooling may be used in lieu of the 60 minute cooling time specified for each cycle, provided the handles and feet of the deep fat fryer, cooker/fryer, or fondue appliance being tested is cooled to the ambient room temperature.*

### **36 Handle and Feet Strength Tests**

36.1 Following the test in Deep Fat Fryer, Cooker/Fryer, and Fondue Cycling Test, Section 35, each deep fat fryer, cooker/fryer, or fondue appliance is to be supported in the intended manner by the handle assembly while loaded with lead shot covered with paraffin having a weight equivalent to two times the weight of the maximum intended capacity of vegetable shortening. The test weight is to be distributed so that the normal horizontal center of gravity is not changed. The handle is to be gripped over a 2 – 4 inch (51 – 102 mm) wide gripping area, centered over the intended gripping area for this test. If more than one handle is furnished, the weight is to be distributed between handles. The samples are then to be rotated, so as to pour in the intended direction, around the axis through the handles from the horizontal through 135 degrees and then back to horizontal for a total of 1000 cycles at a rate of 6 to 8 cycles per minute. There shall be no:

- a) Loosening of the fastening means that results in loss of pan or basket control or
- b) Cracking or breaking of the handle, its securing means, or that portion of the enclosure to which the handle is attached.

36.2 Following the test in Deep Fat Fryer, Cooker/Fryer, and Fondue Cycling Test, Section 35, each deep fat fryer, cooker/fryer, or fondue appliance is to be supported for 1 minute in the intended manner by the handle assembly while loaded with lead shot having a weight equivalent to four times the weight of the maximum intended capacity of vegetable shortening. The test weight is to be distributed so that the normal horizontal center of gravity is not changed. The handle is to be gripped over a 2 – 4 inch (51 – 102 mm) wide gripping area, centered over the intended gripping area for this test. If more than one handle is furnished, the weight is to be distributed between handles. There shall be no:

- a) Loosening of the fastening means that results in loss of pan or basket control or
- b) Cracking or breaking of the handle, its securing means, or that portion of the enclosure to which the handle is attached.

36.3 Following the test in Deep Fat Fryer, Cooker/Fryer, and Fondue Cycling Test, Section 35, each deep fat fryer, cooker/fryer or fondue appliance is to be supported for 1 minute in the intended manner by the feet assembly while loaded with lead shot having a weight equivalent to four times the weight of the maximum intended capacity of vegetable shortening. The test weight is to be distributed so that the normal horizontal center of gravity is not changed. There shall be no:

- a) Loosening of the fastening means that results in loss of pan or basket control or
- b) Cracking or breaking of the handle, its securing means, or that portion of the enclosure to which the handle is attached.

36.4 Following the test in 36.3, each deep fat fryer, cooker/fryer, or fondue appliance utilizing a hanging or swivel type handle assembly is to be placed on a horizontal surface with the handle positioned to the side of the frying basket at its end of travel stop. The handle shall withstand a ball impact by dropping a 2-inch (50.8-mm) diameter steel sphere, weighing 1.18 lb (0.525 kg) from a height that will produce an impact energy of 1.5 ft-lbf (2.03 N-m). The impact shall be applied to cause the maximum torque about the fastening means. Following this ball impact, there shall be no:

- a) Loosening of the fastening means that results in loss of pan or basket control or
- b) Cracking or breaking of the handle, its securing means, or that portion of the enclosure to which the handle is attached.

36.5 If screws or nuts accessible to the user are intended to be used to secure the handle and feet assemblies of a deep fat fryer, cooker/fryer, or fondue appliance, they are to be retightened after the tests outlined in 36.1 – 36.4, in accordance with the manufacturer's instructions.

*Exception: Tamper-proof screws or nuts are not to be retightened.*

### **36A Detachable Power-Supply Cord Separation Test – Deep-Fat Fryers, Cooker/Fryers, and Fondues**

36A.1 A force gauge is to be attached to the detachable power-supply cord of a deep-fat fryer, cooker/fryer or fondue 12 inches from the appliance. The appliance is to be held securely in place on a horizontal surface. A steadily increasing pull-out force is to be applied to the detachable power-supply cord directly away from the power-supply cord inlet (0°), at a right angle to the power-supply cord inlet (90°), at a 180° angle, and at any angle between 0° and 180° that is intended to represent the worst case. Regardless of the angle of the power-supply cord relative to the inlet, the pullout force shall be in the horizontal direction (parallel to the countertop surface) and perpendicular to the front edge of the countertop. The maximum force required to separate the detachable power-supply cord from the appliance is then to be recorded.

Revised 36A.1 effective May 30, 2001

36A.2 A deep-fat fryer, cooker/fryer, or fondue, at room temperature and with any basket provided removed, is to be placed on a horizontal surface having a coefficient of static friction of  $0.20 \pm .02$  as determined by 36A.3 and consisting of laminated thermosetting countertop type material having a smooth matte finish and adhered to a wood base surface rigidly fixed for the intended use. The deep-fat fryer, cooker/fryer, or fondue is to be filled with the manufacturers recommended minimum level of oil. A steadily increasing force is to be applied by a force gauge in the horizontal direction and at the height of the power-supply cord inlet. The force required to overcome the static friction of the appliance is then to be recorded.

36A.3 The coefficient of static friction of the test surface in 36A.2 shall be established by use of a test block weighing 7.55 lbs (33.7 N) and having a surface area of 32 in<sup>2</sup> (206 cm<sup>2</sup>). The surface is to consist of 304 stainless steel with a No. 3 finish. The coefficient of static friction is to be determined by the equation:  $\mu = F_s/W$  where  $F_s$  is the force required to overcome the static friction between the test block and the test surface, and where  $W$  is the weight of the test block.

36A.4 The maximum force required to separate the detachable power-supply cord from the appliance, as determined in 36A.1, shall be at least 5 percent less than the force required to overcome the static friction of the appliance, as determined in 36A.2.

Revised 36A.4 effective May 30, 2001

### 37 Thermal Degradation Test

37.1 A thermoset material used for a part of an appliance where risk of fire, electric shock or injury to persons is involved shall be resistant to thermal degradation at the maximum temperature to which it is exposed during normal use of the appliance. The thermal-aging characteristics of the material may be investigated by any one of the following procedures:

- a) The material shall have a temperature index, based on historical data or a long-term thermal aging program, described in the Standard for Polymeric Materials – Long Term Property Evaluations, UL 746B, which indicates acceptability for use at the temperature involved or
- b) The appliance shall be operated with the input voltage adjusted so that the part in question operates at the maximum temperature obtained during the normal temperature test. The test is to be conducted with all temperature controls by-passed for a period of 1000 hours. There shall be no visible degradation of parts at the conclusion of the 1000 hours.

### 38 Mechanical Endurance Test

38.1 If the normal operation of a waffle-maker-type appliance causes movement of the internal wiring, the appliance shall be capable of operating for 6000 cycles in the intended manner while connected to a supply circuit of the voltage indicated in 38.2. There shall be no electrical or mechanical malfunction and, after the test, the appliance shall comply with the requirements for dielectric voltage-withstand in 32.1 and 32.2.

38.2 In a test to determine whether a waffle-maker-type appliance complies with the requirement in 38.1 (such as in the operation of the upper part of a waffle iron), any appropriate mechanical arrangement may be employed to operate the movable member at a rate of approximately 12 cycles per minute, but, in any case, the cover or movable member is to be so operated that it will reach the actual limits of travel in both directions, each cycle. In the case of an appliance such as a sandwich toaster that has two different stop positions for the hinged cover, 1000 operations out of the total of 6000 are to be made with the cover moved to the wide-open position. The appliance is to be operated at reduced voltage or with resistors in series with the supply circuit so that the temperature produced on the grid will be 210°C (410°F) in the case of a waffle iron and 275°C (527°F) in the case of a sandwich toaster or the like.

### **39 Broken Element Test**

39.1 An open-wire heating element in an appliance shall be so constructed and supported so that if the wire is cut at any point there shall be no reduction of electrical spacings below the limits specified in this standard. After being cut, no portion of the heating element wire shall be accessible to contact by the articulate probe through any opening in the enclosure.

39.2 To determine compliance with 39.1:

- a) The appliance is first to have been operated until fully heated as in the Power Input Test, Section 26, or the temperature tests, and
- b) After cutting the heating element, the appliance is to be rotated 360 degrees in the direction most likely to cause contact between the heating element and accessible parts.

### **40 Abnormal Operation Test**

#### **40.1 General**

40.1.1 If the conditions of normal operation are not representative also of abnormal conditions likely to be obtained in actual service, an appliance shall not involve a risk of fire or electric shock when operated continuously under such abnormal conditions.

40.1.2 The appliance shall have its voltage selector switch set in any supply circuit voltage position being connected to any one of the rated supply circuits. The combination of selector settings and supply circuit to which the equipment is connected is to be that which develops the most severe operating conditions.

No Text on This Page

40.1.3 If provided, an externally operable input voltage selector is to be operated for 25 cycles with the appliance operating at the minimum rated voltage and for 25 cycles with the appliance at the maximum rated voltage. Each cycle consisting of moving the voltage selector to its alternate position and back at the rate of six cycles per minute with the voltage selector in each position for 5 seconds. The operating and temperature controls are to be set as to result in the most adverse operating conditions.

*Exception: If an externally operable voltage selector switch interlocks with the power switch and cannot be operated with the power switch in the on position, the test procedure will be as described in 40.1.4.*

40.1.4 For an externally operable voltage selector switch that interlocks with the power switch and cannot be operated with the power switch in the on position, the voltage selector is to be operated for 25 cycles each at the maximum and minimum voltages. Each cycle is to consist of the following steps:

- a) With the power switch in the off position, move the voltage selector to the alternate position;
- b) Turn the power switch on and operate the appliance for 5 seconds;
- c) Turn the power switch off;
- d) Move the voltage selector to the original position; and
- e) Turn the power switch on and operate the appliance for 5 seconds.

40.1.5 To determine whether a risk of fire or electric shock actually exists, a separate burnout or abnormal test is to be conducted with the appliance operating continuously until the ultimate result has been observed. Unless otherwise indicated below, the test is to be conducted with the applied voltage, method of mounting, and thermostat connection in accordance with 30.1.12 – 30.1.17. Accessible metal parts, those that can be contacted by the probe in Figure 6.2, and metal parts accessible during user-servicing are to be connected to ground through a 3-A fuse. In most cases, continuous operation for 7 to 8 hours will be necessary to determine that the ultimate result has been observed. The appliance is to be placed on white tissue paper on a softwood surface.

40.1.6 An appliance is to be located as close to the walls of the test corner as the construction will permit. The test corner is to consist of dull black-painted fir plywood not less than 3/8 inch (9.5 mm) thick, having such width that the wall will extend not less than 2 ft (0.61 m) beyond the physical limits of the appliance. The vertical walls are to meet at a right angle. The test corner is to be provided with a 12-inch (300-mm) deep simulated cabinet bottom, located 16 inches (400 mm) above the counter top. The simulated cabinet bottom is to be of the same material as the test corner walls.

*Exception No. 1: The test corner need not be used if temperatures obtained are not a factor affecting the results.*

*Exception No. 2: When an appliance is more than 16 inches (406 mm) high and not more than 22 inches (559 mm) high, the cabinet bottom is to be just over the appliance. When the appliance is more than 22 inches high, the cabinet bottom is to be omitted.*

40.1.7 When operated under such abnormal conditions, an appliance is considered to involve a risk of fire if there is any emission of flame or molten metal (other than drops of melted solder), or if the operation of the appliance results in the glowing or flaming of combustible material upon which the appliance may be placed, or that may be adjacent to the appliance.

40.1.8 An appliance is considered to involve a risk of electric shock if the 3-A fuse connected from accessible metal parts of the appliance to ground opens during the test.

40.1.9 After having been subjected to an abnormal test, the appliance is considered to involve a risk of electric shock if the current measured through a 500 ohm resistor connected between an accessible part and ground is more than 5 mA. A solution of hard water (0.5 g of calcium sulphate  $\text{CaSO}_4 \cdot 2\text{H}_2\text{O}$  per liter of distilled water) in an amount equal to the capacity of the container is to be poured into the container, and the current is to be measured as quickly as possible thereafter. Liquid need not be added if it is apparent that the appliance will not hold liquid.

## 40.2 Specific test conditions

40.2.1 For most of the common types of heating appliances, standardized abnormal test conditions are given in 40.2.2 – 40.7.1.

40.2.2 If an appliance has an exterior surface of glass, ceramic, or comparably brittle material in or on which the heating element is mounted or which is an essential part of the enclosure of live parts, the material shall be capable of withstanding the stresses likely to be encountered in actual service.

40.2.3 Certain specific tests are described in 40.2.4 and 40.2.5, but other tests may be necessitated by the design or intended operation of the appliance.

40.2.4 The glass or ceramic surface shall withstand without cracking or breaking the application of a cloth fully saturated with water (the hard water solution described in 40.1.9) at room temperature, with the appliance in the fully heated condition. The quantity of water involved shall be sufficient to wet the surface completely. The appliance shall then comply with the requirement in 27.1 in a repeat leakage current test, except that the test shall be discontinued when leakage current stabilizes.

40.2.5 An appliance with a glass or ceramic surface shall withstand without cracking or breaking the impact of a utensil loaded with shot to a mass of 4 lb (1.81 kg) and dropped from a height of 6 inches (152 mm). The size and shape of the utensil shall be as appropriate as possible for the particular appliance, and 10 drops of the utensil shall be made.

## 40.3 Deep-fat fryers/cooker-fryers/fondues

40.3.1 The appliance is to be operated with fresh unused pure cold pressed peanut oil at the recommended level, with the thermostat set at the position that gives maximum heat, and with the appliance initially at room temperature. An oil temperature higher than  $390^\circ\text{C}$  ( $734^\circ\text{F}$ ) at any time during the test is not acceptable. The test is then to be repeated with all oil drained from the appliance, but with a residual film of oil within the fat kettle. With reference to 30.1.17, the regulating thermostat is not to be defeated during this test. The cover, if provided, is not to be in place during these tests.

40.3.2 The test in 40.3.1 is to be repeated with all temperature controls other than the temperature limiting device defeated. There shall be no ignition or flash of vaporized oil as a result of this test. For the test, the appliance is to be filled to the recommended level, the basket filled with french fry potatoes and the cover is to be removed.



#### 40.4 Skillets

40.4.1 The appliance is to be tested as indicated in 40.3.1 except that initially 1/2 inch (12.7 mm) of pure cold pressed peanut oil is to be in the skillet.

#### 40.5 Waffle bakers, sandwich grills, hamburger makers and donut makers

40.5.1 One sample of the appliance is to be operated dry with the cover closed and, if construction permits, one sample with the cover open, first 90° if a stop is provided, and then 180° if the position is attainable. The thermostat is to be adjusted to its maximum setting in each case.

#### 40.6 Corn poppers

40.6.1 Two tests shall be made. For the first test, one tablespoon of pure peanut oil shall be placed in the appliance. With the cover in place, the appliance shall be operated from a cold start until ultimate results are obtained.

40.6.2 For the second test, one tablespoon of oil shall be used, unless more is needed for the formation of oily condensate on the cover. With the cover in place, the appliance shall be operated from a cold start, and:

- a) For automatic corn poppers, the cover shall be lifted from the appliance within 5 seconds after the cooking surface reaches its maximum temperature, following the initial cutout of the temperature controlling device.
- b) For nonautomatic corn poppers, the cover shall be lifted from the appliance 10 minutes after the start of the test. If equilibrium has not occurred within 10 minutes, the test shall be repeated from cold start and the cover shall be removed at the time that equilibrium is reached.

There shall be no ignition or flash of vaporized oil as a result of this test.

40.6.3 Lifting the cover as indicated in 40.6.2 shall be accomplished by raising the cover and tilting it in such a manner that the oily condensate formed on the inside of the cover drips back onto the heated surface.

#### 40.7 Griddles and crepe makers

40.7.1 The appliance is to be operated dry with all adjustable temperature controls, if provided, at the maximum setting.

40.7.2 In addition to the applicable test described in 40.2.2 – 40.7.1, a dual voltage appliance shall be subjected to the tests described in 40.1.2 – 40.1.4. These tests are subject to the test conditions described in 40.1.5 and 40.1.6 and to the acceptance criteria described in 40.1.7 – 40.1.9. There shall be no electrical or mechanical breakdown of the voltage selector switch.

## 41 Temperature Probe Insertion Test

41.1 Each of six samples is to be subjected to 50 cycles of insertion and withdrawal of the temperature-probe plug. The cycles are to be performed manually at a rate of speed no greater than 6 cycles per minute, under rated load. At the completion of 50 cycles, the voltage drop at rated current shall not exceed 50 mV between the male and female contacts of the temperature probe plug. There shall be no mechanical failure of the temperature probe plug, nor shall there be any undue deterioration, pitting, or burning of the probe contacts.

## 42 Control Devices Tests

### 42.1 Automatic controls

42.1.1 An automatic control for temperature regulating or temperature limiting shall be capable of performing successfully for 50 cycles of operation when the appliance is connected to a supply circuit having a potential of 120 percent of the voltage specified in 30.1.12. There shall be neither electrical or mechanical malfunction of the control, or undue burning, pitting, or welding of the contacts.

42.1.2 In tests to determine whether an automatic control complies with the requirements in 42.1.1, the appliance is to be connected to a grounded supply circuit; the enclosure of the appliance, if of metal, is to be connected to ground through a 3-A fuse; and the control, if single-pole, is to be connected to an ungrounded conductor of the circuit. The device is to be operated at the rate of 10 cycles per minute, except that a faster rate of operation may be employed if agreeable to all concerned. The performance is unacceptable if the fuse in the grounding connection opens during the test.

### 42.2 Endurance

#### 42.2.1 Thermostats

42.2.1.1 A thermostat shall be capable of withstanding an endurance test which shall consist of the number of cycles indicated in Table 42.1. Unless it is specified that the test be made without load, the thermostat shall make and break the rated current of the appliance while connected to a circuit of rated voltage. There shall be neither electrical or mechanical malfunction of the thermostat, or undue burning, pitting, or welding of the contacts.

42.2.1.2 With reference to 42.2.1.1 and Table 42.1, thermostats are classified as follows:

- a) A temperature-regulating thermostat is one which functions only to regulate the temperature of the heating appliance under normal conditions of use, and whose malfunction would not result in a risk of fire.
- b) A temperature-limiting thermostat is one that functions only under conditions that produce abnormal temperatures. The malfunction of such a thermostat might not result in a risk of fire.
- c) A combination temperature-regulating and -limiting thermostat is one that functions to regulate the temperature of the heating appliance under normal conditions of use, and also serves to prevent a fire that might result from conditions of abnormal operation of the appliance.

**Table 42.1**  
**Number of cycles of operation for endurance test**

Type of thermostat	Automatically reset thermostat	Manually reset thermostat
Temperature regulating	A number of cycles equivalent to 1000 hours of intended operation of the appliance, but not less than 6000 cycles. However, the test may be omitted if, with the thermostat short-circuited, no temperature higher than the limits given in Table 30.1 are attained during the normal-temperature test of the appliance	To be made the subject of special consideration.
Temperature-limiting <sup>a</sup>	A number of cycles equivalent to 100 hours of operation of the heating appliance under any condition which causes the thermostat to function, or 100,000 cycles, whichever is greater. However, the test may be omitted if, with the thermostat short-circuited, there is no evidence of risk of fire as described in 42.1.1 – 42.2.1.2 during the continuous abnormal operation of the appliance.	1000 cycles under load and 5000 cycles without load. However, the test may be omitted if, with the thermostat short-circuited, there is no evidence of risk of fire as described in 42.1.1 – 42.2.1.2 during continuous abnormal operation of the appliance.
Combination temperature -regulating and -limiting <sup>a</sup>	100,000 cycles if, with the thermostat short-circuited, there is evidence of risk of fire as described in 42.1.1 – 42.2.1.2. If there is no evidence of risk of fire under this condition, the thermostat is to be tested as temperature-regulating thermostat (see above).	To be made the subject of special consideration

<sup>a</sup> See 21.1 and 21.2.

### 43 Permanence of Marking

43.1 A required marking shall be molded, die-stamped, paint-stenciled, stamped or etched metal that is permanently secured, or indelibly stamped lettering on a pressure-sensitive label secured by adhesive that upon investigation is found to be acceptable for the application. Ordinary usage (including the likely exposure to weather and other ambient conditions), handling, storage, and the like of the equipment is to be considered in the determination of the acceptability of the application.

43.2 Unless it has been investigated and found to be acceptable for the application, a pressure-sensitive label or label that is secured by cement or adhesive shall comply with the adhesion requirements in Table 7.1 for indoor equipment, and Table 7.2 for outdoor equipment in the Standard for Marking and Labeling Systems, UL 969.

43.3 A required cautionary marking shall be located on a part that would require tools for removal or that cannot be removed without impairing the operation of the product.

## 44 Test for Permanence of Cord Tag – Deep Fat Fryers and Cooker/Fryers

### 44.1 General

44.1.1 To determine compliance with 48.15 and 48.16, representative samples that have been subjected to the tests described in 44.1.3 – 44.2.1 shall meet the following requirements:

- a) The tag shall resist tearing for longer than 1/16 inch (1.6 mm) at any point;
- b) The tag shall not separate from the power supply cord;
- c) There shall be no permanent shrinkage, deformation, cracking, or any other condition that will render the marking on the tag illegible; and
- d) Overlamination shall remain in place and not be torn or otherwise damaged. The printing shall remain legible.

44.1.2 For each type of conditioning mentioned in 44.1.3 – 44.1.6, three samples of the tag applied to the power supply cord in the intended manner are to be used. If tags are applied by an adhesive, tests are to be conducted no sooner than 25 hours after application of the tag.

44.1.3 Three samples are to be tested as received.

44.1.4 Following conditioning in an air-circulating oven at  $60.0 \pm 1.0^\circ\text{C}$  ( $140.0 \pm 1.8^\circ\text{F}$ ) for 240 hours, three samples are to be tested after 30 minutes of conditioning at a room temperature of  $23.0 \pm 2.0^\circ\text{C}$  ( $73.4 \pm 3.6^\circ\text{F}$ ) and 50  $\pm$ 5 percent relative humidity.

44.1.5 Three samples are to be tested within 1 minute after exposure for 72 hours to a humidity of 85  $\pm$ 5 percent at  $32.0 \pm 2.0^\circ\text{C}$  ( $89.6 \pm 3.6^\circ\text{F}$ ).

44.1.6 Three samples are to be tested within 1 minute after being immersed in cooking oil at room temperature of  $23.0 \pm 2.0^\circ\text{C}$  ( $73.4 \pm 3.6^\circ\text{F}$ ) for 2 hours.

### 44.2 Test method

44.2.1 Each sample is to consist of a length of power supply cord to which the tag has been applied. The power supply cord, with the attachment plug pointing up, is to be held tautly in a vertical plane. A force of 5 lbf (22.2 N) is to be applied to the upper-most corner of the tag farthest from the power supply cord, within 1/4 inch (6.4 mm) of the vertical edge of the tag. The force is to be applied vertically downward in a direction parallel to the major axis of the cord. In determining compliance with 44.1.1(c), manipulation is permissible, such as straightening of the tag by hand. To determine compliance with 44.1.1(d), each sample is to be scraped 10 times across printed areas and edges, with a force of approximately 2 lbf (8.9 N), using the edge of a 5/64 inch (2.0 mm) thick steel blade held at a right angle to the test surface.

## MANUFACTURING AND PRODUCTION-LINE TESTS

### 45 Dielectric Voltage-Withstand Test

45.1 Each appliance shall withstand without an indication of unacceptable performance as a routine production-line test, the application of a potential between the primary wiring, including connected components, and accessible metal parts that are likely to become energized, and between primary wiring and accessible low voltage (42.4 V peak or less) metal parts, including terminals. The test potential shall be 1200 V applied for 1 second or 1000 V applied for 1 minute.

45.2 The appliance may be in a heated or unheated condition for the test.

45.3 The test shall be conducted with the appliance complete – fully assembled. It is not intended that the appliance be unwired, modified, or disassembled for the test.

*Exception No. 1: A part, such as a snap cover or a friction-fit knob, that would interfere with performance of the test need not be in place.*

*Exception No. 2: The test may be performed before final assembly if such a test represents testing the complete appliance.*

45.4 If the appliance employs a solid-state component that can be damaged by the test potential, the test on each appliance may be conducted before the component is electrically connected. In such a case, additional testing is to be made of a random sampling of each day's production with the circuitry rearranged to reduce the likelihood of damage to any solid-state component but retaining representative dielectric stress of the circuit.

45.5 The test equipment, when adjusted for production-line testing, is to produce an output voltage that is not less than the factory test value specified, nor is the magnitude of the test voltage to be greater than 120 percent of the specified test potential when the tester is used in each of the following conditions:

- a) If the test duration is 1 second, the output voltage is to be maintained within the specified range,
  - 1) When only a voltmeter having an input impedance of at least 2 megohms and a specimen of the product being tested are connected to the output terminals, and
  - 2) When a relatively high resistance is connected in parallel with the voltmeter and the product being tested, and the value of the resistance is gradually reduced to the point where an indication of unacceptable performance just occurs.
- b) If the test duration is 1 minute, the output voltage is to be maintained within the specified range, by manual or automatic means, throughout the 1 minute duration of the test or until there is an indication of unacceptable performance.

45.6 The specified control of the applied voltage, manual or automatic, shall be maintained under conditions of varying line voltage. Higher test potentials may be used if the higher dielectric stress is not likely to adversely affect the insulating systems of the product.

45.7 In addition to the characteristics indicated in 45.5, the test equipment is to have the following features and characteristics:

- a) A means of indicating the test voltage that is applied to the product under test. This may be accomplished by sensing the voltage at the leads or by equivalent means.
- b) An output voltage that
  - 1) Has a sinusoidal waveform,
  - 2) Has a frequency that is within the range of 40 – 70 Hz, and
  - 3) Has a peak value of the waveform that is not to be less than 1.3 and not more than 1.5 times the root-mean-square value.
- c) A means of effectively indicating unacceptable performance. The indication is to be
  - 1) Auditory if it can be readily heard above the background noise level,
  - 2) Visual if it commands the attention of the operator, or
  - 3) A device that automatically rejects an unacceptable appliance. If the indication of unacceptable performance is auditory or visual, the indication is to remain active and conspicuous until the test equipment is reset manually.
- d) When the test equipment is adjusted to produce the test voltage and a resistance of 120,000 ohms is connected across the output, the test equipment is to indicate an unacceptable performance within 0.5 second. A resistance of more than 120,000 ohms may be used to produce an indication of unacceptable performance, if the manufacturer elects to use a tester having higher sensitivity.

45.8 There is not to be any transient voltage applied to the appliance under test that results in the instantaneous voltage applied to the product exceeding 120 percent of the peak value of the test voltage that the manufacturer elects to use for this test. This requirement applies for the entire duration of the test, including the time that the voltage is first applied to the product and the time that the voltage is removed from the product.

45.9 During the test, a sufficient number of primary switching components shall be in the on position so that all primary circuitry will be stressed. Both sides of the primary circuit of the appliance are to be connected together to one terminal of the test equipment. The second equipment terminal is to be connected to accessible dead metal.

*Exception: Resistive-type appliances and appliances utilizing motors, relays, coils or transformers, having circuitry not subjected to excessive secondary build-up in case of indication of unacceptable performance during the test, may be tested with only one side of the primary circuit connected to the dielectric test equipment.*

## 46 Polarization and Grounding Continuity Tests

### 46.1 Polarization test

46.1.1 Each appliance provided with a polarized attachment plug (2-wire plug with one blade wider than the other) shall be tested for electrical continuity between the grounded supply-circuit conductor of the attachment plug (wide blade of a 2-wire plug) and the part of the appliance that is intended to be connected to the grounded supply-circuit conductor. If the continuity cannot be readily determined by visual inspection and component checking, an electrical-continuity test is to be made.

### 46.2 Continuity of grounding connection

46.2.1 Each cord-connected appliance having provision for grounding shall be tested, as a routine production-line test, to determine that grounding continuity exists between the ground blade of the attachment plug and the accessible dead metal parts of the appliance that are likely to become energized.

46.2.2 Only a single test need be conducted if the accessible metal selected is conductively connected by design to all other accessible metal.

### 46.3 Electrical indicating device

46.3.1 Any indicating device, such as an ohmmeter, a battery and buzzer combination, or the like, may be used to determine compliance with the tests described in 46.1.1 – 46.2.2.

## RATING

### 47 Details

47.1 An appliance shall be rated in amperes, voltamperes, or watts, also in volts, and may be rated for alternating current only. The rating shall include the frequency if necessary because of control devices.

## MARKING

### 48 Details

48.1 A warning or caution marking shall comply with all of the following requirements:

- a) The marking shall be permanently attached
- b) The marking shall not be attached to parts removable by hand.
- c) The marking shall be attached to parts that cannot be removed without impairing the operation of the appliance or left off the appliance without being readily apparent.
- d) The marking shall have lettering that complies with the following requirements:
  - 1) The precautionary signal word (such as "DANGER", "WARNING", OR "CAUTION") shall be in letters not less than 3/32 inch (2.4 mm) high.
  - 2) If contrasting color is used lettering other than signal words can be a minimum of 1/16 inch (1.6 mm) high.

48.2 All other markings required in this section shall be such that the marking is clear and legible under conditions of intended use of the appliance.

48.3 An appliance shall be legibly and permanently marked with:

- a) The manufacturer's name, trade name, trademark, or other descriptive marking by which the organization responsible for the product may be identified;
- b) The date or other dating period of manufacture not exceeding any three consecutive months, that may be abbreviated or in a nationally accepted conventional code, or, in a code affirmed by the manufacturer;
- c) A distinctive (catalog) (model) number or the equivalent; and
- d) The electrical rating. A date code repetition time cycle shall not be less than 10 years.

48.4 An appliance shall be marked, where readily visible, to indicate that the appliance is intended for household type usage, such as, "Household Use Only" "Household Type", and the like. Lettering shall not be less than 3/32 inch (2.4 mm) high.

48.5 If a manufacturer produces or assembles appliances at more than one factory, each finished appliance shall have a distinctive marking – which may be in code – by which it may be identified as the product of a particular factory.

48.6 If the design of an appliance contemplates disassembly by means of a tool for the purpose of cleaning or similar servicing by the user (including replacement of a fusible link) and, if such disassembly involves the exposure of persons to unintentional contact with any normally enclosed or protected live part, the appliance shall be plainly marked with a warning that such servicing should be done only while the appliance is disconnected from the supply circuit. See also 6.14.

48.7 The instructions required in 9.1.3 are to include the following information:

- a) A short power-supply cord (or detachable power-supply cord) is to be provided to reduce the risk resulting from becoming entangled in or tripping over a longer cord.
- b) Longer detachable power-supply cords or extension cords are available and may be used if care is exercised in their use.

*Exception: An extension cord or longer detachable cord is not recommended for use with deep-fat fryers and cooker/fryers.*

- c) If a long detachable power-supply cord or extension cord is used,
  - 1) The marked electrical rating of the cord or extension cord should be at least as great as the electrical rating of the appliance,



2) If the appliance is of the grounded type, the extension cord should be a grounding 3-wire cord, and

3) The longer cord should be arranged so that it will not drape over the countertop or table top where it can be pulled on by children or tripped over unintentionally.

48.8 An appliance that is likely to be lifted and handled for cleaning purposes and has not been subjected to the Immersion Tests, in accordance with 30.1.6 and 31.2.1 shall be marked "Do not immerse in water" or with an equivalent wording. If the appliance is intended for partial immersion but not for complete immersion, it shall be marked "Do not immerse beyond this point" or with an equivalent wording to show the point beyond which it should not be immersed.

48.8 revised December 24, 1998

48.9 An appliance that is intended for use with a thermostatically controlled appliance plug shall be permanently marked "Use only (manufacturer) (designation) temperature-controlling plug" or with an equivalent wording.

48.10 A tag, sticker, or label shall be affixed or attached to a corn popping appliance in such a manner that intentional detachment by the user is necessary to cause its removal. It shall be placed where plainly visible after unpacking with the appliance in the intended operating position. It shall bear the following marking, or the equivalent: "CAUTION – A burn can result from misuse of this product. Read instruction manual for proper operating procedure."

48.11 The statements appearing on the tag, sticker, or label required in 48.10 shall be in letters not less than 3/32 inch (2.4 mm) high.

48.12 An appliance that utilizes a detachable power-supply cord shall be provided with:

a) The appropriate detachable power-supply cord as indicated in Section 8, or

b) Instructions that advise the consumer that the appropriate detachable power-supply cord set is not provided, and specify which detachable power-supply cords are appropriate. If long and short detachable power-supply cords are available, the instructions shall include information regarding the problems attendant with each.

48.13 The instructions in 48.12(b) shall be marked on the outer packaging material of the product, and in the instruction manual provided with the appliance.

*Exception: The outer packaging material alone may carry the information from the instructions in 48.12(b) provided that the instruction manual supplied with the appliance contains a reference to the location of the information.*

48.14 An appliance that is shipped with the legs disassembled shall comply with the following:

a) The carton containing the appliance is to be marked to inform the consumer that the product is not completely assembled, and

b) The appliance cooking surface is to be provided with a nonpermanent type marking stating "WARNING – To reduce the risk of fire, assemble feet before using – see instructions." or an equivalent statement following the word WARNING.

48.15 A deep-fat cooker/fryer; or a skillet or fry pan shall be provided with a tag that is permanently attached to the power supply cord located within 2 inches (51 mm) of the plug when shipped from the factory. The tag material and means of attachment to the power supply cord shall comply with the requirements in Test for Permanence of Cord Tag – Deep Fat Fryers and Cooker/Fryers, Section 44. The tag shall contain the word "WARNING" and the following instructions or the equivalent:

**WARNING**

SERIOUS HOT-OIL BURNS MAY RESULT FROM A DEEP-FAT FRYER (COOKER/ FRYER, SKILLET, OR FRY PAN) BEING PULLED OFF A COUNTERTOP. DO NOT ALLOW THE CORD TO HANG OVER THE EDGE OF THE COUNTER WHERE IT MAY BE GRABBED BY CHILDREN OR BECOME ENTANGLED WITH THE USER.

DO NOT USE WITH AN EXTENSION CORD.

The words "WARNING" and "DO NOT USE WITH AN EXTENSION CORD" in the above marking shall be in red letters at least 3/16 inch (4.8 mm) in height. All other letters on the tag shall be black and not less than 1/16 inch (1.6 mm) in height. All letters shall be uppercase.

*Exception: A skillet or fry pan having a power supply cord no longer than 42 inches as measured from the face of the plug to the entrance of the cord into the appliance, need not be provided with the tag specified in 48.15.*

48.16 The reverse side of the warning tag shall provide the pictorial warning illustrated in Figure 48.1 including the cautionary statements shown or the equivalent. The illustration shall be in black, with x-marks and statements in red. The width of the illustration shall not be less than 1 inch (25.4 mm) and the height not less than 2 inches (50.8 mm). Letter height shall not be less than 3/16 inch (4.8 mm).

Figure 48.1  
Warning tag

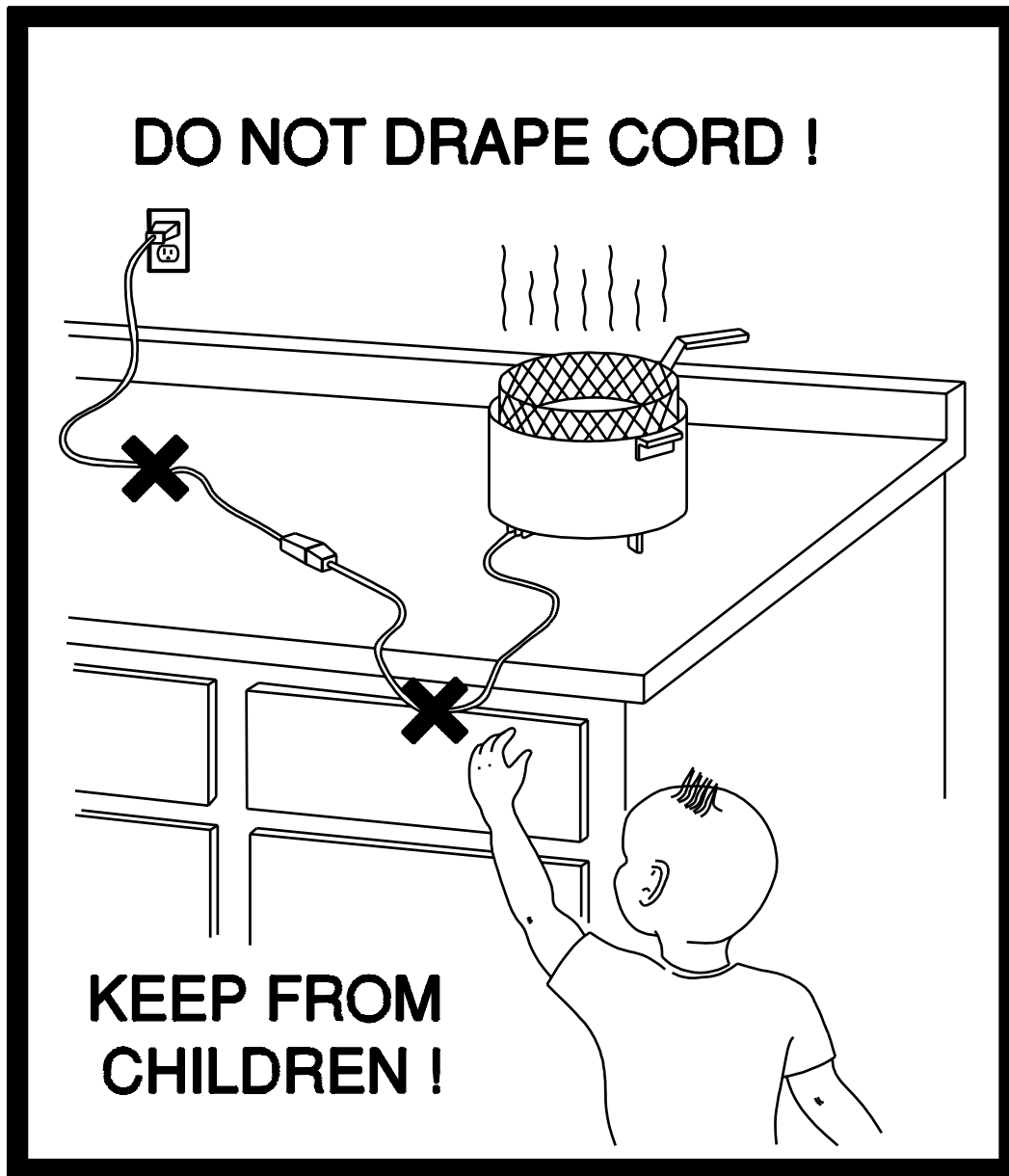

S3529

SERIOUS HOT-OIL BURNS MAY RESULT FROM A DEEP FAT FRYER OR COOKER/FRYER BEING PULLED OFF OF A COUNTERTOP. DO NOT ALLOW THE CORD TO HANG OVER THE EDGE OF THE COUNTERTOP WHERE IT MAY BE GRABBED BY CHILDREN OR BECOME ENTANGLED WITH THE USER.

DO NOT USE WITH AN EXTENSION CORD.

## 49 Carton Marking

49.1 A carton (individual marketing container) for an appliance shall be marked to indicate that the appliance is intended for household type usage, such as, "Household Use only", "Household Type", and the like. The marking shall:

- a) Be located on at least one outside surface and
- b) Appear in lettering not less than the height specified in Table 49.1

**Table 49.1**  
**Lettering height**

Smallest dimension of the carton panel to be marked in inches (mm)		Minimum height of lettering in inches (mm)
More than	Less than or equal or	
0	6 (152)	1/8 (3.2)
6 (152)	10 (254)	3/16 (4.8)
10 (254)	—	1/4 (6.4)

## INSTRUCTION MANUAL

### 50 General

50.1 An instruction manual or the equivalent shall be provided with the appliance. The manual shall specifically warn the user against each potential risk and state the precautions that should be taken to guard against each risk. The safety instructions shall be a permanent part of the manual but separated in format from the other instructions, and shall appear before the operating instructions in the manual.

50.2 The instruction manual shall include instructions or illustration to identify important safety features.

50.3 Clear instructions detailing the proper assembly of the handle to a deep-fat fryer basket shall be provided in the instruction manual in other than the "Important Safeguards." See 52.1.

50.4 The height of lettering in the text and illustrations of the Safety Instructions shall be as follows:

- a) Upper case letters shall not be less than 1/12 inch (2.11 mm) in height;
- b) Lower case letters shall not be less than 1/16 inch (1.6 mm) in height;
- c) The phrases "IMPORTANT SAFE-GUARDS" and "SAVE THESE INSTRUCTIONS" shall be in letters no less than 3/16 inch (4.8 mm) in height.

50.5 The instruction manual shall include the important safeguards in All Appliances, Section 51, and the appropriate text from Specific Appliances, Section 52.

50.6 Unless otherwise indicated, the text of the instructions shall be verbatim to, or in equally definitive terminology as, Sections 51 and 52, except where specific conflict exists in the application of the text to a product where the risk alluded to has been reduced. The items may be numbered, and the phrases "Read all Instructions" and "Save These Instructions" shall be first and last, respectively, in a list of items. Other important and appropriate safeguard items considered appropriate by the manufacturer may be inserted.

50.7 The manufacturer's instructions shall include a statement indicating that preheating of the appliance is not necessary if preheating the appliance prior to the temperature or abnormal tests was waived based on such instructions. See 30.1.21.

50.8 The manufacturer's instructions provided with a sandwich grill shall include a statement indicating that the appliance is not to be operated in the open position.

*Exception: A sandwich grill that was tested in both the open and closed position need not comply with this requirement. See 30.2.3.2.*

50.9 For a dual voltage rated appliance, procedures to be followed in changing the voltage selector, if provided and providing the correct supply connection means for each voltage setting shall be provided. In addition, the following wording or equivalent shall be provided: "For use in the U.S.A., the voltage selector switch should be placed in the 120 volt position. For use in several countries overseas, the voltage selector may need to be placed in the 240 volt position. Confirm the voltage available at each overseas location before using the appliance. For connection to a 240 volt supply, use an attachment plug adapter of the proper configuration for the power supply receptacle."

50.10 An appliance provided with a 2-wire polarized attachment plug shall include the following or equivalent wording: "This appliance has a polarized plug (one blade is wider than the other). To reduce the risk of electric shock, this plug is intended to fit into a polarized outlet only one way. If the plug does not fit fully into the outlet, reverse the plug. If it still does not fit, contact a qualified electrician. Do not attempt to modify the plug in any way."

## 51 All Appliances

51.1 The following applies to all appliances:

### IMPORTANT SAFEGUARDS

When using electrical appliances, basic safety precautions should always be followed, including the following:

1. Read all Instructions.
2. Do not touch hot surfaces. Use handles or knobs.
3. To protect against electric shock do not immerse cord, plugs, or (state specific part or parts in question) in water or other liquid.
4. Close supervision is necessary when any appliance is used by or near children.
5. Unplug from outlet when not in use and before cleaning. Allow to cool before putting on or taking off parts, and before cleaning the appliance.
6. Do not operate any appliance with a damaged cord or plug or after the appliance malfunctions, or has been damaged in any manner. Return appliance to the nearest authorized service facility for examination, repair or adjustment.
7. The use of accessory attachments not recommended by the appliance manufacturer may cause injuries.
8. Do not use outdoors (this item may be omitted if the product is specifically designed for outdoor use).
9. Do not let cord hang over edge of table or counter, or touch hot surfaces.
10. Do not place on or near a hot gas or electric burner, or in a heated oven.
11. Extreme caution must be used when moving an appliance containing hot oil or other hot liquids.
12. Always attach plug to appliance first, then plug cord in the wall outlet. To disconnect, turn any control to "off," then remove plug from wall outlet.
13. Do not use appliance for other than intended use.
14. SAVE THESE INSTRUCTIONS.

## 52 Specific Appliances

### 52.1 Deep fryers

1. "Extreme caution must be used when moving fryer containing hot oil."
2. "Be sure handles are properly assembled to basket and locked in place. See detailed assembly instructions."

### 52.2 Fondues, woks, tempuras

1. "Extreme caution must be used when moving (state the name of the appliance) containing hot oil."

### 52.3 Corn poppers

1. "A popper that is plugged into an outlet should not be left unattended."
2. "This popper will not shut off automatically. To avoid overheating, add corn and oil before operating." (This item may be omitted for automatic corn poppers.)
3. "Extreme caution must be used when unloading popcorn. Always turn the unit over a counter-top so that residual hot oil or water running out will not cause burns."

### 52.4 Appliances with detachable handles

1. "Be sure that handles are assembled and fastened properly."
2. (The manufacturer shall supply explicit instructions detailing the proper assembly of the handles.)
3. (The manufacturer shall explain how improper assembly of the handles can be determined.)

*Exception: Items 2 and 3 may be located in any part of the Instruction Manual provided that the important safeguards state "See instructions regarding handles on page \_\_\_\_\_" or the equivalent wording.*

### 52.5 Appliances with legs disassembled for shipment

1. "Be sure legs are assembled and fastened properly."
2. (The manufacturer shall supply explicit instructions detailing the proper assembly of the legs by providing an assembly diagram, a list of tools required for assembly, and a list of loose parts provided to be assembled.)
3. (The manufacturer shall explain how improper assembly of the legs can be determined.)

*Exception: Items 2 and 3 may be located in any part of the Instruction Manual provided that the Important Safeguards state "See instructions regarding assembly of leg on page \_\_\_\_\_" or the equivalent wording.*

## 52.6 Dual voltage rated appliances.

1. "Be sure dual voltage selector, if provided, is in correct voltage position before operating. Before plugging in, read the information about the dual voltage contained in instruction section of this manual."
2. "This appliance was set at the factory to be operated at \_\_\_\_ volts. Refer to operating instructions section of this manual for conversion to \_\_\_\_ volt operation" or equivalent. The blanks are to be filled in with the appropriate voltage information.

*Exception: This construction does not apply if an appliance operates over a range of voltages and requires no adjustment by the user, such as an appliance that employs a positive temperature coefficient (PTC) heating element intended for use over a range of voltages and requiring no adjustment by the user.*

## 53 User Maintenance

53.1 The instruction manual shall include instructions and caution statements for cleaning, user-maintenance (such as lubrication or non-lubrication) operations recommended by the manufacturer, and shall warn a user that any other servicing should be performed by an authorized service representative. The manual or other literature packaged with the product shall also indicate that the product is for household use.

53.2 The instruction manual for a deep fat fryer, cooker/fryer, or fondue that employs screws or nuts accessible to the user to secure handle and feet assemblies shall instruct the user to periodically check for looseness and retighten screws or nuts in accordance with the manufacturer's instructions. In addition, the instruction manual shall contain the following or the equivalent preceded by the word "CAUTION": "Overtightening can result in stripping of screws or nuts or cracking of handle or feet."



## APPENDIX A

### Standards for Components

Standards under which components of the products covered by this standard are evaluated include the following:

Title of Standard – UL Standard Designation

---

Title of Standard – UL Standard Designation

Attachment Plugs and Receptacles – UL 498

Cord Sets and Power-Supply Cords – UL 817

Extruded Insulating Tubing – UL 224

Flexible Cord and Fixture Wire – UL 62

Polymeric Materials – Long Term Property Evaluations – UL 746B

Polymeric Materials – Short Term Property Evaluations – UL 746A

Polymeric Materials – Use in Electric Equipment Evaluations – UL 746C

Polyvinyl Chloride, Polyethylene, and Rubber Insulating Tape – UL 510

Quick-Connect Terminals, Electrical – UL 310

Rubber-Insulated Wires and Cables – UL 44

Switches, Special-Use – UL 1054

Temperature-Indicating and -Regulating Equipment – UL 873

Thermal Cutoffs for Use in Electrical Appliances and Components – UL 1020

Thermoplastic-Insulated Wires and Cables – UL 83

Wire Connectors and Soldering Lugs for Use With Copper Conductors – UL 486A

No Text on This Page

## **APPENDIX B**

### **Food Color Charts**

A good brown color is to be close to the middle color shown as practical, but not lighter than the lightest color or darker than the darkest color.

A color photo of this chart accompanies this computer file

Toast Color Chart

Waffle Color Chart

French Fries Color Chart

(12/31/84)

No Text on This Page