

UL 250

ISBN 1-55989-461-X

# Household Refrigerators and Freezers



Underwriters Laboratories Inc. (UL)  
333 Pfingsten Road  
Northbrook, IL 60062-2096

UL Standard for Safety for Household Refrigerators and Freezers, UL 250

Tenth Edition, Dated November 1, 1993

Revisions: This Standard contains revisions through and including August 25, 2000.

UL is in the process of converting its Standards for Safety to the Standard Generalized Markup Language (SGML), and implementing an SGML compliant document management and publishing system. SGML - an international standard (ISO 8879-1986) - is a descriptive markup language that describes a document's structure and purpose, rather than its physical appearance on a page. Significant benefits that will result from UL's use of SGML and these new systems include increased productivity, reduced turnaround times, and data and information consistency, reusability, shareability, and portability. However, the fonts, pagination, and general formatting of UL's new electronic publishing system differ from that of UL's previous publishing system. Consequently, when revision pages are issued for a Standard with the new publishing system, these differences may result in the printing of pages on which no requirements have been changed - these additional pages result from relocation of text due to repagination and reformatting of the Standard with the new publishing system.

Text that has been changed in any manner is marked with a vertical line in the margin. Changes in requirements are marked with a vertical line in the margin and are followed by an effective date note indicating the date of publication or the date on which the changed requirement becomes effective.

The new and revised requirements are substantially in accordance with UL's Bulletin(s) on this subject dated December 19, 1997 and April 16, 1999. The bulletin(s) is now obsolete and may be discarded.

The revisions dated August 25, 2000 include a reprinted title page (page1) for this Standard.

The revisions dated August 25, 2000 include updates to outside references and other editorial revisions.

As indicated on the title page (page 1), this UL Standard for Safety is an American National Standard. Attention is directed to the note on the title page of this Standard outlining the procedures to be followed to retain the approved text of this ANSI/UL Standard.

As indicated on the title page (page1), this UL Standard for Safety has been adopted by the Department of Defense.

The master for this Standard at UL's Northbrook Office is the official document insofar as it relates to a UL service and the compliance of a product with respect to the requirements for that product and service, or if there are questions regarding the accuracy of this Standard.

UL's Standards for Safety are copyrighted by UL. Neither a printed copy of a Standard, nor the distribution diskette for a Standard-on-Diskette and the file for the Standard on the distribution diskette should be altered in any way. All of UL's Standards and all copyrights, ownerships, and rights regarding those Standards shall remain the sole and exclusive property of UL.

All rights reserved. No part of this publication may be reproduced, stored in a retrieval system, or transmitted in any form by any means, electronic, mechanical photocopying, recording, or otherwise without prior permission of UL.

Revisions of UL Standards for Safety are issued from time to time. A UL Standard for Safety is current only if it incorporates the most recently adopted revisions.

UL provides this Standard "as is" without warranty of any kind, either expressed or implied, including but not limited to, the implied warranties of merchantability or fitness for any purpose.

In no event will UL be liable for any special, incidental, consequential, indirect or similar damages, including loss of profits, lost savings, loss of data, or any other damages arising out of the use of or the inability to use this Standard, even if UL or an authorized UL representative has been advised of the possibility of such damage. In no event shall UL's liability for any damage ever exceed the price paid for this Standard, regardless of the form of the claim.

UL will attempt to answer support requests concerning electronic versions of its Standards. However, this support service is offered on a reasonable efforts basis only, and UL may not be able to resolve every support request. UL supports the electronic versions of its Standards only if they are used under the conditions and operating systems for which it is intended. UL's support policies may change from time-to-time without notification.

UL reserves the right to change the format, presentation, file types and formats, delivery methods and formats, and the like of both its printed and electronic Standards without prior notice.

Purchasers of the electronic versions of UL's Standards for Safety agree to defend, indemnify, and hold UL harmless from and against any loss, expense, liability, damage, claim, or judgement (including reasonable attorney's fees) resulting from any error or deviation introduced while purchaser is storing an electronic Standard on the purchaser's computer system.

If a single-user version electronic Standard was purchased, one copy of this Standard may be stored on the hard disk of a single personal computer, or on a single LAN file-server or the permanent storage device of a multiple-user computer in such a manner that this Standard may only be accessed by one user at a time and for which there is no possibility of multiple concurrent access.

If a multiple-user version electronic Standard was purchased, one copy of the Standard may be stored on a single LAN file-server, or on the permanent storage device of a multiple-user computer, or on an Intranet server. The number of concurrent users shall not exceed the number of users authorized.

Electronic Standards are intended for on-line use, such as for viewing the requirements of a Standard, conducting a word search, and the like. Only one copy of the Standard may be printed from each single-user version of an electronic Standard. Only one copy of the Standard may be printed for each authorized user of a multiple-user version of an electronic Standard. Because of differences in the computer/software/printer setup used by UL and those of electronic Standards purchasers, the printed copy obtained by a purchaser may not look exactly like the on-line screen view or the printed Standard.

An employee of an organization purchasing a UL Standard can make a copy of the page or pages being viewed for their own fair and/or practical internal use.

The requirements in this Standard are now in effect, except for those paragraphs, sections, tables, figures, and/or other elements of the Standard having future effective dates as indicated in the note following the affected item. The prior text for requirements that have been revised and that have a future effective date are located after the Standard, and are preceded by a "SUPERSEDED REQUIREMENTS" notice.

New product submittals made prior to a specified future effective date will be judged under all of the requirements in this Standard including those requirements with a specified future effective date, unless the applicant specifically requests that the product be judged under the current requirements. However, if

the applicant elects this option, it should be noted that compliance with all the requirements in this Standard will be required as a condition of continued Listing and Follow-Up Services after the effective date, and understanding of this should be signified in writing.

Copyright © 2000 Underwriters Laboratories Inc.

This Standard consists of pages dated as shown in the following checklist:

Page	Date
1-8	August 25, 2000
9-13	November 1, 1993
14	August 25, 2000
15	November 1, 1993
16-16B	August 25, 2000
17-18	November 1, 1993
19-24	August 25, 2000
25-33	November 1, 1993
34-34A	August 25, 2000
34B	April 29, 1998
35-40	November 1, 1993
41-44	August 25, 2000
44A-44B	April 29, 1998
45	November 1, 1993
46-48B	June 23, 1997
49-52	November 1, 1993
53	August 25, 2000
54	November 1, 1993
55	August 25, 2000
56	April 29, 1998
57-60	November 1, 1993
61-62B	June 23, 1997
63	November 1, 1993
64	June 23, 1997
65	November 1, 1993
66-66B	August 25, 2000
67-69	November 1, 1993
70	June 23, 1997
71-73	November 1, 1993
74-74B	April 29, 1998
75-76B	August 25, 2000
77	November 1, 1993
78-80B	August 25, 2000
81-82	November 1, 1993
83-84B	June 23, 1997
85	November 1, 1993
86-86B	April 29, 1998
87-88	August 25, 2000
SA1-SA10	August 25, 2000
A1-A8	August 25, 2000
B1-B2	February 1, 1994

No Text on This Page

Canadian Standards Association  
CAN/CSA-C22.2 No. 63-93  
Fourth Edition

Underwriters Laboratories Inc.  
UL 250  
Tenth Edition



## Household Refrigerators and Freezers

November 1993

(Title Page Reprinted: August 25, 2000)



## **Commitment for Amendments**

This Standard is issued jointly by Canadian Standards Association and Underwriters Laboratories Incorporated. Amendments to this Standard will be made only after processing according to the Standards writing procedures by both Canadian Standards Association and Underwriters Laboratories Incorporated.

*Approval as an American National Standard (ANSI) covers the numbered paragraphs on pages dated November 1, 1993. These pages should not be discarded when revised or additional pages are issued if it is desired to retain the ANSI approved text.*

*Approved as ANSI/UL 250-1997, July 30, 1997*

*The Department of Defense (DoD) has adopted UL 250 on March 23, 1976. The publication of revised pages or a new edition of this Standard will not invalidate the DoD adoption.*

**ISSN 0317-5669**

**Copyright © 1993, 1994**

**CSA International**

*All rights reserved. No part of this publication may be reproduced in any form whatsoever without the prior permission of the publisher.*

**ISBN 1-55989-461-X**

**Copyright © 1993, 2000**

**Underwriters Laboratories Inc.**



**CONTENTS**

<b>Preface</b> .....	<b>6</b>
<b>Foreword (CSA)</b> .....	<b>7</b>
<b>FOREWORD</b> .....	<b>8</b>
1 Scope .....	9
2 Definitions .....	9
3 General .....	11
3.1 Components .....	11
3.2 Units of measurement .....	12
3.3 Undated references .....	12
4 Construction .....	12
4.1 General .....	12
4.2 Enclosures .....	13
4.3 Mechanical protection .....	13
4.4 Electrical protection .....	15
4.5 Assembly .....	16A
4.6 Accessories .....	18
4.7 Latch-release mechanism .....	19
4.8 Polymeric materials – application .....	20
4.9 Field supply connections .....	22
4.10 Wiring and wiring methods .....	31
4.11 Secondary circuits .....	36
4.12 Separation of circuits .....	37
5 Electrical Components .....	38
5.1 Capacitor .....	38
5.2 Current-carrying parts .....	39
5.3 Defrost heaters .....	39
5.4 Guarding of lamps .....	40
5.5 Incandescent lighting systems .....	41
5.6 Insulating material .....	41
5.7 Motors and motor overload protection .....	42
5.8 Switches and controllers .....	44A
5.9 Transformers, power converters, and power inverters .....	46
6 Electrical Spacings .....	46
6.1 Line-voltage circuits .....	46
6.2 Extra-low voltage (Class 2) circuits .....	48
7 Refrigeration System .....	48A
7.1 Refrigerant .....	48A
7.2 Refrigerant tubing and fittings .....	48A
7.3 Refrigerant-containing parts .....	50
7.4 Pressure relief .....	50
8 Performance .....	50
8.1 Instrumentation .....	50
8.1.2 Pressure measurements .....	51
8.2 Test voltage and frequency .....	51
8.3 Leakage current test – cord-connected refrigerators .....	52
8.4 Component washing test .....	54
8.5 Input test .....	56

8.6	Temperature and pressure test	56
8.7	Starting test	61
8.8	Dielectric voltage-withstand test	61
8.9	Defrost test	62
8.10	Defrost heater burnout test	63
8.11	Condenser fan motor failure test	63
8.12	Overflow test	64
8.13	Spill test	64
8.14	Stability test	64
8.15	Static load test – cabinets	65
8.16	Strain relief test	66
8.17	Overvoltage and undervoltage tests	67
8.18	Limited short circuit test	67
8.19	Current overload test – bonding conductors and connections	68
8.20	Defrost heater control tests	68
8.21	Insulation resistance test	69
8.22	Accelerated aging test – electric heaters	69
8.23	Reliability test – heater terminations	70
8.24	Strength tests – pressure containing components	70
8.25	Shelf strength test	72
8.26	Component restraint test	73
8.27	Glass strength test	73
8.28	Door latch release test	73
8.29	Door hinge strength test	74
8.30	Impact test	74A
9	Polymeric Materials – Performance	75
9.1	Electrical enclosure flammability	75
9.2	Vertical burning test – 5VA, 5VB, materials	76
9.3	Vertical burning test – V-0, V-1, or V-2 solid materials	76
9.4	Horizontal burning test – HB materials	76
9.5	Horizontal burning test – HBF, HF-1, or HF-2 foamed materials	76A
9.6	Mold stress-relief test	77
9.7	Fastener strength test	77
9.8	Adhesive test	78
9.9	Flame spread test	78
9.10	Volume resistivity test	79
9.11	High-current arc ignition test	79
9.12	Hot wire ignition test	79
9.13	Burnout test – impedance protected motors	80
9.14	Electrical disturbance test	80
9.15	Grounding continuity test	80
9.16	Distortion test	81
9.17	Heating test – condensate wiring	81
10	Manufacturing and Production Tests	82
10.1	Pressure tests	82
10.2	Production line dielectric voltage-withstand tests	83
10.3	Production line grounding continuity test	84A
11	Marking	84A
11.1	General	84A
11.2	Installation and operating instructions	87

**SUPPLEMENT SA - REQUIREMENTS FOR REFRIGERATORS AND FREEZERS EMPLOYING A  
FLAMMABLE REFRIGERANT IN THE REFRIGERATING SYSTEM**

SA1	Scope .....	.SA1
SA2	Definitions .....	.SA1
SA3	General .....	.SA2
SA4	CONSTRUCTION .....	.SA3
	SA4.1 General .....	.SA3
	SA4.2 Valves/Fittings .....	.SA3
	SA4.3 Resistance to Corrosion .....	.SA4
SA5	PERFORMANCE .....	.SA4
	SA5.1 Leakage Test .....	.SA4
	SA5.2 Ignition test .....	.SA6
	SA5.3 Temperature test .....	.SA7
	SA5.4 Scratch test .....	.SA7
SA6	MARKING AND INSTALLATION AND OPERATING INSTRUCTIONS .....	.SA9
	SA6.1 Marking .....	.SA9
	SA6.2 Installation and operating instructions .....	.SA10

**Appendix A****Standards for Components**

A1	Component Standards .....	.A1
A2	Other Standards .....	.A6

**Appendix B****Marking Translations**

## Preface

This is the common UL and CSA Standard for Household Refrigerators and Freezers. It is the Fourth edition of CAN/CSA-C22.2 No. 63 Household Refrigerators and Freezers and the tenth edition of UL 250, Household Refrigerators and Freezers.

This common Standard was prepared by Canadian Standards Association and Underwriters Laboratories Inc., and the appliance manufacturing industry. The efforts and support of the Canadian Appliance Manufacturers Association (CAMA) and the Association of Home Appliance Manufacturers (AHAM) are gratefully acknowledged.

This Standard was reviewed by the CSA Subcommittee of the Technical Committee on Consumer and Commercial Products under the jurisdiction of the CSA Steering Committee on the Canadian Electrical Code, Part II, and was approved by these committees.

This Standard will be submitted to the Standards Council of Canada for approval as a National Standard of Canada.

This Standard has been approved by the American National Standards Institute (ANSI) as an American National Standard.

*Note: Although the intended primary application of this Standard is stated in its Scope, it is important to note that it remains the responsibility of the users of the Standard to judge its suitability for their particular purpose.*

### **UL Effective Date**

As of August 25, 2000 all products Listed or Recognized by UL must comply with the requirements in this Standard except for the Clauses in the following list which are effective August 27, 2001.

Clause 11.1.26. Table 11.1.

Between August 25, 2000 and August 27, 2001, new product submittals to UL may be evaluated under all requirements in this Standard or, if requested in writing evaluated, under presently effective requirements only. The presently effective requirements are contained in the tenth edition of UL 250.

### **CSA Effective Date**

The effective date for CSA will be announced through *CSA Informs* or *CSA Certification Notice*.

## Foreword (CSA)

The Canadian Standards Association, which operates under the name CSA International (CSA), provides certification services for manufacturers who, under license from CSA, wish to use the appropriate registered CSA Marks on certain products of their manufacture to indicate conformity with CSA Standards.

CSA Certification for a number of products is provided in the interest of maintaining agreed-upon standards of quality, performance, interchangeability and/or safety, as appropriate. Where applicable, certification may form the basis for acceptance by inspection authorities responsible for enforcement of regulations. Where feasible, programs will be developed for additional products for which certification is desired by producers, consumers or other interests.

In performing its functions in accordance with its objectives, CSA does not assume or undertake to discharge any responsibility of the manufacturer or any other party. The opinions and findings of the Association represent its professional judgement given with due consideration to the necessary limitations of practical operation and state of the art at the time the Standard is processed.

Products in substantial accord with this Standard but which exhibit a minor difference or a new feature may be deemed to meet the Standard providing the feature or difference is found acceptable utilizing appropriate CSA Certification and Testing Division Operating Procedures. Products which comply with this Standard shall not be certified if they are found to have additional features which are inconsistent with the intent of this Standard. Products shall not be certifiable if they are discovered to contravene applicable laws or regulations.

Testing techniques, test procedures and instrumentation frequently must be prescribed by the CSA Certification and Testing Division in addition to the technical requirements contained in Standards of CSA. In addition to markings specified in the Standard, the CSA Certification and Testing Division may require special cautions, markings and instructions that are not specified by the Standard.

Some tests required by CSA Standards may be inherently hazardous. The Association neither assumes nor accepts any responsibility for any injury or damage that may occur during or as the result of tests, wherever performed, whether performed in whole or in part by the manufacturer or the Association, and whether or not any equipment, facility or personnel for or in connection with the test is furnished by the manufacturer or the Association.

Manufacturers should note that, in the event of the failure of the CSA Certification and Testing Division to resolve an issue arising from the interpretation of requirements, there is an appeal procedure: the complainant should submit the matter, in writing, to the Secretary of the Canadian Standards Association.

If this Standard is to be used in obtaining CSA Certification please remember, when making application for certification, to request all current Amendments, Bulletins, Notices and Technical Information Letters that may be applicable and for which there may be a nominal charge. For such information or for further information concerning CSA Certification please address your inquiry to Applications and Customer Service, CSA International, 178 Rexdale Boulevard, Toronto, Ontario M9W 1R3.

## FOREWORD

A. This Standard contains basic requirements for products covered by Underwriters Laboratories Inc. (UL) under its Follow-Up Service for this category within the limitations given below and in the Scope section of this Standard. These requirements are based upon sound engineering principles, research, records of tests and field experience, and an appreciation of the problems of manufacture, installation, and use derived from consultation with and information obtained from manufacturers, users, inspection authorities, and others having specialized experience. They are subject to revision as further experience and investigation may show is necessary or desirable.

B. The observance of the requirements of this Standard by a manufacturer is one of the conditions of the continued coverage of the manufacturer's product.

C. A product which complies with the text of this Standard will not necessarily be judged to comply with the Standard if, when examined and tested, it is found to have other features which impair the level of safety contemplated by these requirements.

D. A product employing materials or having forms of construction which conflict with specific requirements of the Standard cannot be judged to comply with the Standard. A product employing materials or having forms of construction not addressed by this Standard may be examined and tested according to the intent of the requirements and, if found to meet the intent of this Standard, may be judged to comply with the Standard.

E. UL, in performing its functions in accordance with its objectives, does not assume or undertake to discharge any responsibility of the manufacturer or any other party. The opinions and findings of UL represent its professional judgment given with due consideration to the necessary limitations of practical operation and state of the art at the time the Standard is processed. UL shall not be responsible to anyone for the use of or reliance upon this Standard by anyone. UL shall not incur any obligation or liability for damages, including consequential damages, arising out of or in connection with the use, interpretation of, or reliance upon this Standard.

F. Many tests required by the Standards of UL are inherently hazardous and adequate safeguards for personnel and property shall be employed in conducting such tests.

# Household Refrigerators and Freezers

## 1 Scope

1.1 This Standard applies to self-contained household refrigerators and freezers designed to be installed and used in residential occupancies in accordance with the Canadian Electrical Code, Part I, CSA Standard C22.2, and the National Electrical Code, ANSI/NFPA 70.

1.2 These requirements apply to household refrigerators and freezers intended for connection to 15 or 20 A, 100 to 140 V or 15 A, 200 to 250 V, single phase, alternating-current (ac) circuits; and combination ac/dc circuits or direct-current (dc) circuits where the dc voltage does not exceed 30 V.

1.3 The terms "appliance", "refrigerator", "product", "equipment", and "unit" are used interchangeably and refer to all household refrigerators, combination refrigerator-freezers, freezers, and refrigerated kitchen units or any part thereof covered by this Standard unless specifically noted otherwise.

1.4 The equipment is air-cooled employing hermetic refrigerant motor-compressors or is of the absorption type employing electricity as a heat source. These requirements apply to (a) freestanding, wall-hung, recessed, and built-in refrigerators and freezers; (b) refrigerators and freezers for use in recreational vehicles; (c) refrigerated kitchen units; and (d) accessories.

1.5 A product that contains features, characteristics, components, materials, or systems new or different from those in use when the Standard was developed, and that involves a risk of fire, electric shock, or injury to persons, shall be evaluated using the appropriate additional component and end-product requirements as determined necessary to maintain the level of safety for the user of the product as originally anticipated by the intent of this Standard.

## 2 Definitions

2.1 For the purpose of this Standard, the following definitions apply.

2.2 **ABSORPTION TYPE REFRIGERATOR** – A refrigerator in which electricity is used as a heat source.

2.3 **ACCESSORY** – An optional electrical device, such as an ice maker, intended for installation in or connection to a refrigerator for the purpose of modifying or supplementing the functions of the refrigerator. It may be factory installed or intended for installation by the user or service personnel.

2.4 **BARRIER** – A partition for the insulation or isolation of electric circuits, for the isolation of electric arcs, or for isolation of moving parts or hot surfaces. In this respect, a barrier may serve as a portion of an enclosure or as a functional part.

2.5 **BOND STRENGTH** – The load applied in tension, compression, flexure, peel, impact, cleavage, or shear, required to break an adhesive assembly with failure occurring in or near the plane of the bond.

2.6 **BUILT-IN REFRIGERATOR (OR FREEZER)** – A recessed type refrigerator (or freezer) intended for slide-in installation, into a confined space and trimmed to blend with room decor.

**2.7 CIRCUIT, EXTRA-LOW VOLTAGE** – A circuit that has an ac potential of not more than 42.4 V peak (30 V), and power of 100 VA or less; or 30 V dc supplied by a primary battery; or supplied by a Class 2 transformer; or supplied by a combination of a transformer and fixed impedance that, as a unit, complies with all the performance requirements for a Class 2 transformer. A circuit that is derived from a circuit that exceeds 30 V by connecting resistance or impedance, or both, in series with the supply circuit to limit the voltage and current, is not considered to be an extra-low voltage circuit.

**2.8 CIRCUIT, LINE VOLTAGE** – A circuit having characteristics in excess of those of an extra-low voltage circuit.

**2.9 CONTROL, DEFROST CYCLE** – A control that is intended to regulate a normal defrost cycle.

**2.10 CONTROL, TEMPERATURE-LIMITING** – A control that serves to prevent excessive temperature.

**2.11 DESIGN PRESSURE** – The maximum allowable working pressure for which the appliance is designed.

**2.12 ENCLOSURE** – A part that by itself or in conjunction with barriers (1) renders inaccessible all or any parts that may otherwise present a risk of electric shock, (2) reduces the risk of contact with parts that may cause injury to persons, or (3) prevents propagation of flame due to electrical disturbances occurring within. A cabinet that serves to enclose electrical components or wiring is considered to be an enclosure.

**2.13 FREESTANDING REFRIGERATOR (OR FREEZER)** – A unit designed for installation in other than a confined space.

**2.14 FUNCTIONAL (STRUCTURAL) PART** – A part used to maintain the intended relative physical position of fixed or moving parts, or maintain the integrity of the structure. A cabinet liner that supports an electrical component is considered to be a functional part.

**2.15 FUSIBLE PLUG** – A device having a predetermined-temperature fusible member for the relief of pressure.

**2.16 HIGH SIDE** – The part of a refrigerating system under condenser pressure.

**2.17 HOUSEHOLD REFRIGERATOR** – A cabinet or any part of a cabinet that is designed for the refrigerated storage of food at temperatures above 0°C (32°F) that has a source of refrigeration and that is intended for residential use. It may include a compartment for the freezing and storage of ice, for storage of food, or both at temperatures below 0°C (32°F).

**2.18 HOUSEHOLD FREEZER** – A cabinet that is designed for the extended storage of frozen food at a temperature of -17.8°C (0°F) or below and with inherent capability for freezing of food, that (1) has a source of refrigeration and (2) is intended for residential use.

**2.19 JUNCTION BLOCK** – A device in which connections between wires are enclosed.

**2.20 LOW SIDE** – The part of a refrigerating system under evaporator pressure.

**2.21 NONFUNCTIONAL PART** – A part, such as thermal insulation or decorative material, that does not serve as electrical insulation or to support or enclose electrical components, maintain electrical spacings, or protect against injury to persons.



**2.22 POWER CONVERTER** – A device that changes alternating-current power to direct-current power, or vice versa.

**2.23 POWER INVERTER** – A device that changes direct-current power to alternating-current power.

**2.24 PRESSURE-LIMITING DEVICE** – A pressure-responsive mechanism deigned to automatically stop the operation of the pressure-imposing element at a predetermined pressure.

**2.25 RECESSED REFRIGERATOR (OR FREEZER)** – A unit designed for installation in a confined space.

**2.26 REFRIGERATED KITCHEN UNIT** – A unit consisting of a refrigerator in combination with a range, a sink, or both.

**2.27 SAFETY CIRCUIT (OR CONTROL DEVICE)** – For the purposes of this Standard, a safety circuit (or control device) is a circuit (or control device) which is relied upon to reduce a risk of fire, electric shock, or injury to persons.

**2.28 SECONDARY CIRCUITS** – Those circuits supplied from transformer output windings which are electrically separated from the input windings.

**2.29 SELF-CONTAINED REFRIGERATOR** – A completely factory-made and factory-tested assembly to which no refrigerant-containing parts are connected in the field.

**2.30 TEMPERATURE-LIMITING THERMOSTAT** – A thermostat that functions only under conditions that produce abnormal temperatures. The failure of such a thermostat might result in a hazard.

**2.31 WALL-HUNG REFRIGERATOR (OR FREEZER)** – A unit intended to be suspended from the outside of a wall using the hardware specified by the manufacturer.

### **3 General**

#### **3.1 Components**

3.1.1 Except as indicated in Clause 3.1.2, a component of a product covered by this standard shall comply with the applicable requirements for that component. See Appendix A for a list of Standards covering components generally used in the products covered by this Standard. A component shall comply with both the Underwriters Laboratories Inc. and the Canadian Standards Association Standards for the component.

3.1.2 A component is not required to comply with a specific requirement that:

- a) Involves a feature or characteristic not required in the application of the component in the product covered by this standard, or
- b) Is superseded by a requirement in this standard.

3.1.3 A component shall be used in accordance with its ratings for the intended conditions of use.

3.1.4 Specific components are recognized (accepted) as being incomplete in construction features or restricted in performance capabilities. Such components are intended for use only under limited conditions, such as certain temperatures not exceeding specified limits, and shall be used only under those specific conditions for which they have been investigated.

### **3.2 Units of measurement**

3.2.1 If a value for measurement as given in this Standard is followed by an equivalent value in other units, the second value may only be approximate. The first stated value is the requirement. The values given in SI (metric) units are the standard. The values given in parentheses are for information only.

### **3.3 Undated references**

3.3.1 Any undated reference to a code or Standard appearing in this Standard shall be interpreted as referring to the latest edition of that code or Standard.

## **4 Construction**

### **4.1 General**

4.1.1 Refrigerators shall be so designed and constructed as to provide protection against:

- a) the hazards of electric shock;
- b) mechanical hazards; and
- c) other hazards as included in this Standard.

4.1.2 If corrosion of a ferrous metal part will contribute to or cause a hazard as stated in Clause 4.1.1, the part shall be protected against corrosion by metallic or nonmetallic coatings, such as plating or painting. This requirement shall not apply to parts such as washers, screws, bolts, and the like, where corrosion of such unprotected parts would not affect compliance with the requirements of this Standard. This requirement shall also not apply to surfaces of sheet steel and cast iron if oxidation of steel or iron due to exposure of the metal to air and moisture is not likely to be appreciable, considering the metal thickness and temperature.

4.1.3 Fiberglass thermal insulation shall not be used in areas where forced air movement could cause particles to be blown into food storage compartments.

4.1.4 Exposed unimpregnated asbestos material shall not be used in air handling or food storage compartments. The unprotected edge of a gasket sandwiched between two parts is considered to be exposed.

4.1.5 The electric range portion of a refrigerated kitchen unit shall comply with the applicable requirements in the Standard for Household Electric Ranges, UL 858, and Household Electric Ranges, CSA Standard C22.2 No. 61.

4.1.6 The gas range portion of a refrigerated kitchen unit shall comply with the applicable requirements in the Standard for Household Cooking Gas Appliances, ANSI Z21.1-1990 and the Standard for Recreational Vehicle Cooking Gas Appliances, ANSI Z21.57-1990.

## 4.2 Enclosures

4.2.1 Enclosures shall be formed and assembled so that they will have the strength and rigidity necessary to resist total or partial collapse which may result in a risk of electric shock, injury to persons, or damage to components in the refrigeration and electrical systems. See static load test – cabinets, Clause 8.15; and impact test, Clause 8.30. For polymeric enclosures, see polymeric materials – application, Clause 4.8.

*Exception: This requirement does not apply to refrigerant tubing if the wall thickness of the tubing is acceptable for use in unprotected locations. See Clause 7.2.1.*

## 4.3 Mechanical protection

4.3.1 When installed in its intended manner (see installation and operating instructions, Clause 11.2), openings in the appliance shall be designed or located to reduce the risk of injury to persons due to unintentional contact with (1) moving parts, such as fan blade blower wheels, gears, and belts and (2) surfaces that exceed the temperatures permitted by Items D2 and D3 of Table 8.2. In evaluating openings, parts such as covers, panels, and grilles are to be removed unless (a) tools are required for their removal or (b) when exposed, a moving part is made inoperative through the use of interlocking devices.

4.3.2 The minor dimension of such openings shall not exceed 76.2 mm (3 inches).

*Exception No. 1: Openings may be larger than 76.2 mm (3 inches) if the part is unlikely to be contacted because of the location of fixed components, including baffles, water and refrigerant tubing, drain tubes, and the like.*

*Exception No. 2: Openings in the bottom of a freestanding, recessed, or built-in unit and in the rear panel of a built-in, recessed, or wall-hung unit may be larger than 76.2 mm (3 inches).*

4.3.3 For the purpose of these requirements, the minor dimension of an opening is determined by the largest hemispherically-tipped rod that can be inserted through the opening with a force of 22.3 N (5 pounds).

4.3.4 Openings having a minor dimension of less than 25.4 mm (1 inch) are acceptable if the probe illustrated in Figure 4.1 cannot contact moving parts, hot surfaces, or both. The probe shall be applied (1) with a force of 11.1 N (2.5 pounds), and (2) in any possible configuration and to any depth that the size of an opening will permit. The probe shall be rotated or angled to any possible position before, during, or after insertion through the opening; and, if necessary, the configuration shall be changed after the probe has been inserted through the opening.

Figure 4.1 – Articulate probe

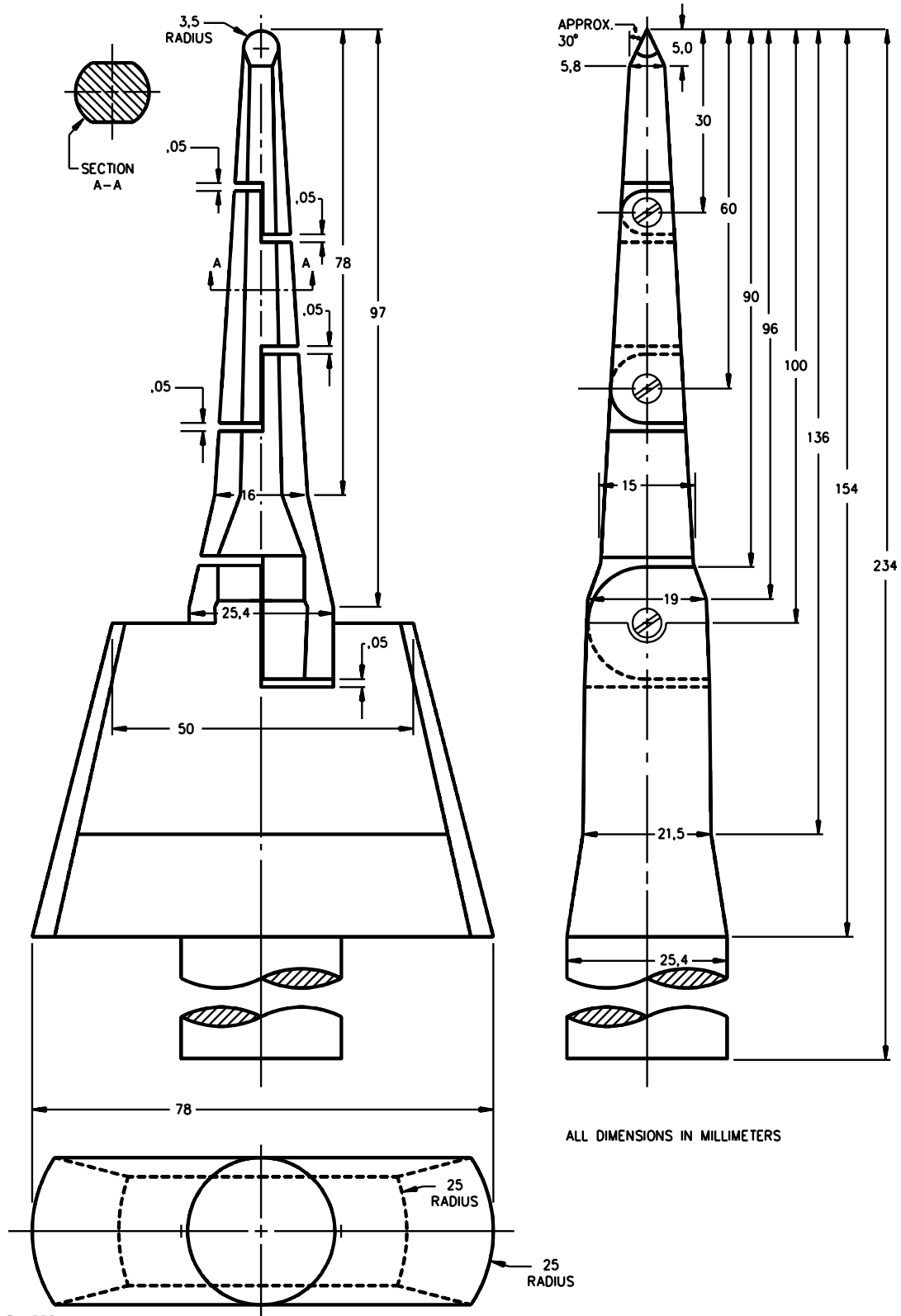

4.3.5 Openings having a minor dimension of 25.4 mm (1 inch) or more are acceptable if the distance from the opening to a moving part or a hot surface is in accordance with Table 4.1.

**Table 4.1 – Dimensions of openings**

Minor dimension of opening <sup>a</sup>		Minimum distance from opening to moving part or hot surface	
mm	Inches	mm	Inches
25.4	1	154	6-1/16
38.1	1-1/2	267.0	10-1/2
50.8	2	368.0	14-1/2
57.2 <sup>b</sup>	2-1/4 <sup>b</sup>	419.0	16-1/2
63.5 <sup>b</sup>	2-1/2 <sup>b</sup>	470.0	18-1/2
69.9 <sup>b</sup>	2-3/4	521.0	20-1/2
76.2 <sup>b</sup>	3 <sup>b</sup>	572.0	22-1/2
Over 50.8	Over 2	762.0	30

<sup>a</sup> For an opening having a minor dimension between two of the values in the table, the distance from the opening to the guarded part shall not be less than that found by interpolation between values in the right-hand column of the table.

<sup>b</sup> These values apply only to openings at the base of the refrigerator where the upper edge of the opening is less than 203.2 mm (8 inches) above the floor.

4.3.6 When tested according to the temperature and pressure test, Clause 8.6, and the defrost test, Clause 8.9, surfaces that exceed the temperature of Items D2 and D3 of Table 8.2 shall be guarded in accordance with Clauses 4.3.1 – 4.3.5.

*Exception: Surfaces that are recessed or located away from the front of the appliance are not considered subject to casual contact (see Item D3 of Table 8.2). Examples of such surfaces include condensers and compressors located at the rear or in the machine compartment of the unit.*

4.3.7 If the temperature on the sheath of a heater element, as installed in the refrigerator, exceeds the limits permitted by Item D2 or Item D3 of Table 8.2, whichever is appropriate, it shall be guarded in accordance with Clauses 4.3.1 – 4.3.5.

#### 4.4 Electrical protection

4.4.1 With the appliance installed in its intended manner (see installation and operating instructions, Clause 11.2), openings in the enclosure shall be designed or located to reduce the risk of unintentional contact with uninsulated parts in line-voltage circuits. The minor dimension of such openings shall not permit passage of a 25.4 mm (1 inch) diameter hemispherically-tipped rod, applied with a force of 22.3 N (5 pounds). In evaluating openings, parts of the enclosure, such as covers, panels, and grilles are to be removed unless (1) tools are required for their removal or (2) when exposed, the uninsulated live part is de-energized through the use of non-defeatable interlocking devices.

4.4.2 The requirements in Clause 4.4.1 also apply to openings in enclosures located within a fresh food compartment or freezer compartment.

4.4.3 An opening is acceptable if the probe illustrated in Figure 4.1 cannot contact uninsulated live parts in line-voltage circuits. The probe shall be applied (1) with a force of 11.1N (2.5 pounds) and (2) in any possible configuration and to any depth that the size of an opening will permit. The probe shall be rotated or angled to any possible position before, during, or after insertion through the opening; and, if necessary, the configuration shall be changed after the probe has been inserted through the opening.

*Exception: For film-coated wire in motors, an opening of 19.1 mm (3/4 inch) or less is acceptable if the probe illustrated in Figure 4.2 cannot contact the wire.*

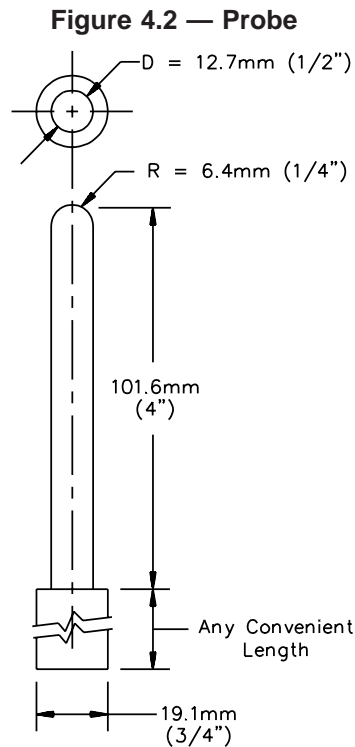

PA170D

4.4.4 In addition to the requirements of Clauses 4.4.1 and 4.4.3 uninsulated live parts and film-coated wire in line-voltage circuits located inside the enclosure and that are likely to be contacted by persons performing operations such as adjusting controls or oiling motors shall be located, guarded, or enclosed to reduce the risk of unintentional contact unless tools are required to expose the live part. See 11.1.26.

## 4.5 Assembly

4.5.1 A refrigerator incorporating a condensing unit of the pull-out type shall be constructed so that the condensing unit can be pulled out and reinserted without kinking or otherwise damaging the refrigerant tubing, and without pinching, abrading, or stressing electrical wiring.

4.5.2 Horizontally-hinged doors that provide access to the food storage compartment(s) of chest-type units shall be (1) counterweighted, (2) spring loaded, or (3) provided with an automatic latch to retain them in the open position. Action members, such as springs and latches shall be enclosed or guarded.

No Text on This Page



4.5.3 Slideout food storage components, such as a drawer or shelf, shall be restrained to prevent being unintentionally pulled free of their supporting means as determined by the component restraint test, Clause 8.26.

*Exception: The types of components specified in Items (a) – (e) need not be restrained:*

- a) a pan, tray, or similar container that rests freely on a shelf or on the storage compartment bottom;*
- b) a component that when loaded as specified in Clause 8.25.3 has a mass not exceeding 4.5 kg (10 pounds);*
- c) a shelf or container located so that the bottom of the shelf or container is not more than 508 mm (20 inches) above the floor, with levelers, if provided, adjusted to raise the refrigerator to its maximum elevation above the floor but not more than 25.4 mm (1 inch);*
- d) a condensate tray not exceeding a 76.2 mm (3 inches) depth or not intended for food storage;*
- e) food storage components in refrigerators having a storage capacity of 0.06 m<sup>3</sup> (2 cubic feet) or less.*

4.5.4 Electrical components shall be located or enclosed so that uninsulated live parts or film-coated wire in line-voltage circuits will not be wetted by liquids due to defrosting or cleaning. See component washing, Clause 8.4, and defrost test, Clause 8.9.

4.5.5 Condensate disposal means, such as a pan, trough, or the like, shall be constructed and located so that overflow will not wet uninsulated live parts or film-coated wire in line-voltage circuits.

4.5.6 An automatic ice maker and the make-up water line shall be constructed and located so that overflow due to a blocked drain, a water inlet valve blocked in the open position, or leakage from a water line connection will not wet uninsulated live parts or film-coated wire in line-voltage circuits.

4.5.7 With reference to Clauses 4.5.5 and 4.5.6, an overflow spout, drain hole, cutout, or the like, in the condensate pan or ice maker may be acceptable for preventing dripping of water on uninsulated live parts or film-coated wire in line-voltage circuits. An overflow test, Clause 8.12, is to be conducted if it is not evident that the refrigerator complies with the requirements of Clauses 4.5.5 and 4.5.6.

4.5.8 Lines for dispensing liquids, ice, and the like shall be located so that leakage at a connection will not result in wetting of uninsulated live parts or film-coated wire in line-voltage circuits.

4.5.9 A refrigerator shall be constructed so that a liquid spill on the top surface of the cabinet will not wet uninsulated live parts or film-coated wire in line-voltage circuits. A spill test, Clause 8.13, is to be conducted if it is not evident that the refrigerator complies with this requirement.

4.5.10 A switch, lampholder, receptacle, motor-attachment plug, or similar component shall be secured in position and shall be prevented from turning. The means for preventing rotation is to consist of more than friction between surfaces. For example, a lock washer is acceptable as means for preventing a small stem-mounted switch or other device having a single-hole mounting means from rotating.

4.5.11 The requirement that a switch be prevented from turning will be waived if all of the following conditions are complied with as specified in Items (a) – (d):

- a) the switch shall be of a plunger or other type that does not tend to rotate when operated. A toggle switch is considered to be subject to forces that tend to rotate the switch during the operation of the switch;
- b) means of mounting the switch make it unlikely that operation of the switch will loosen it;
- c) electrical spacings shall not be reduced below the minimum required values if the switch rotates; and
- d) operation of the switch is by mechanical means rather than direct contact by persons.

4.5.12 A lampholder of a type in which the lamp cannot be replaced, such as a neon pilot or indicator light in which the lamp is sealed in a nonremovable jewel, need not be prevented from turning if rotation cannot reduce electrical spacings below the minimum acceptable values.

4.5.13 An uninsulated current-carrying part and a part that supports a live part shall be secured to its mounting surface so that it will be prevented from turning or shifting in position if such motion may result in a reduction of electrical spacings below the minimum acceptable values. Friction between surfaces is not acceptable as a means to prevent shifting or turning of a live part, but a lock washer as described in Clause 4.5.10 is acceptable.

4.5.14 Flammable or electrically conductive thermal or acoustical insulation shall not contact uninsulated live parts or film-coated wire in line-voltage circuits.

4.5.15 For switches located in areas where disconnection of the leads would result in exposure of an uninsulated live part or reduction of electrical spacings, a means for simultaneous disconnection of the leads shall be provided.

## **4.6 Accessories**

4.6.1 A refrigerator having provisions for the attachment of accessories in the field shall comply with the requirements of this Standard with or without the accessory installed.

4.6.2 Installation of accessories by the user shall be restricted to an arrangement in which electrical connections can be accomplished by means of receptacles and plug-in connectors.

4.6.3 The installation of accessories by service personnel shall be by means of receptacles, plug-in connectors, insulated wire connectors, or by connection to existing wiring terminals.

4.6.4 Installation of accessories that require the cutting of wiring or the soldering of connections by the installer are not acceptable. Installation of accessories by the user shall not require cutting, drilling, or welding. Installation of accessories by service personnel that requires cutting, drilling, or welding of electrical enclosures and in other areas where such operations may damage electrical or refrigeration components and wiring within the enclosure is not acceptable. Installation of accessories shall not require relocation of factory-installed components.

4.6.5 Strain-relief means shall be provided for the wiring in the accessory if there is a possibility of transmitting stress to the terminal connections during or after installation. See strain relief test, Clause 8.16.

4.6.6 The mounting location of the accessory shall be indicated on the refrigerator.

*Exception: If the mounting location is fixed due to the function of the accessory and arrangement of the refrigerator, and instructions are provided covering the installation and location for the accessory, the mounting location of the accessory need not be indicated on the refrigerator.*

4.6.7 As part of the investigation, accessories are to be trial-installed as necessary to determine that their installation is acceptable and that the instructions are detailed and correct.

#### **4.7 Latch-release mechanism**

4.7.1 Except as indicated in Clause 4.7.7, a door or lid permitting entry into a refrigerated storage space that has a minor dimension of 203.2 mm (8 inches) or more and a volume of 0.06 m<sup>3</sup>(2 cubic feet) or more, with any arrangement or removal of shelving, shall be constructed so that it will open easily from the inside by a force applied outwardly to the door or to a release actuator. See door latch release test, Clause 8.28.

4.7.2 With reference to Clause 4.7.1, shelving is defined as any shelf, basket, drawer, or baffle that can be removed from the refrigerator without the use of tools.

4.7.3 Interior latch-release actuators shall function with the refrigerator in its intended operating position and shall be operable from all spaces that are directly accessible when the door(s) is opened.

4.7.4 A magnetic door gasket is considered a door-latching device.

4.7.5 A latch-release device shall not depend on an electrical source for operation.

4.7.6 A latch-release device shall be constructed so that cleaning or defrosting in accordance with the manufacturer's recommendations, or normal condensation will not affect compliance with the door latch release test, Clause 8.28.

4.7.7 A key-lock that cannot be released from the inside is acceptable if the construction complies with all the conditions specified in Items (a) – (d):

- a) the refrigerator complies with the requirements of Clauses 4.7.1, 4.7.3, 4.7.5, and 4.7.6 in the unlocked position;
- b) the lock is of the nonself-engaging type;
- c) the key slot is spring loaded or equivalent so that the key must be manually held in the lock in any position of the lock; and
- d) the key is permanently marked as indicated in Clause 11.1.15.

## 4.8 Polymeric materials – application

### 4.8.1 General

4.8.1.1 The requirements in Clauses 4.8.1.2 – 4.8.1.7, apply to polymeric materials for use in household refrigerators and freezers. These requirements do not apply to control knobs, buttons, insulating bushings, resilient mounts, clamps, wiring straps, seals including door gaskets, door handles, coated metal, food storage components such as shelves, pans, and trays or other small nonfunctional parts. As a guide, small nonfunctional parts may be considered those having an area of less than 0.093 m<sup>2</sup>(1 square foot) and that do not provide direct or indirect support of live parts.

4.8.1.2 Among the factors that are taken into consideration when judging the acceptability of a polymeric material are (1) flame resistance, (2) mechanical strength, (3) resistance to impact, (4) moisture absorptive properties, and (5) resistance to distortion at temperatures to which the material may be subjected under conditions of normal or abnormal usage. All of these factors are considered with respect to aging.

4.8.1.3 Polymeric materials used in areas where the effects of an adjacent lamp may result in distortion shall comply with the requirements in the distortion test, Clause 9.16.

4.8.1.4 Polymeric materials shall be isolated from ignition sources. Ignition sources within the unit are considered to be line-voltage wiring and any electrical components, such as coil windings, splices, open type switches, or arcing parts not enclosed in metal or a polymeric material that has been evaluated as an enclosure. Metal not less than 0.13 mm (0.005 inch) thick, fiberglass not less than 12.7 mm (0.5 inch) thick, or a polymeric material classed as 5V or as an electrical enclosure, are acceptable barriers for isolation of ignition sources.

*Exception No. 1: Impedance protected motors employing open-coil construction need not be isolated as indicated above if they comply with the burnout test – impedance protected motors, Clause 9.13.*

*Exception No. 2: Wiring need not be isolated as indicated above if it is separated from HBF, or HB materials by positive clamping and routing at a minimum of 6.4 mm (1/4 inch). Wiring need not be isolated from 5V, V-0, V-1, V-2, HF-1, or HF-2 materials.*

*Exception No. 3: Wiring need not be isolated if it complies with the VW-1 flame test described in the Reference Standard for Electrical Wires, Cables, and Flexible Cords, UL 1581, or FT1 flame test described in Test Methods for Electrical Wires and Cables, CSA Standard C22.2 No. 0.3.*

*Exception No. 4: Wiring need not be isolated from HB, or HBF materials if the part is additionally evaluated under conditions of the electrical disturbance test, Clause 9.14, or hot wire ignition test, Clause 9.12.*

4.8.1.5 Thermal insulation located between an outer metal cabinet or metal door and inner liner and a refrigerator need not be tested for flammability if (1) all entrance and exit holes for wiring, foaming, and the like located within this volume are sealed with caps, permagum, foil tape or the like, and (2) either the securement of the outer cabinet surfaces is inherent in the construction or the maximum spacing between screws, spot welds, or other securement means on the outer metal cabinet does not exceed 152.4 mm (6 in.).

*Exception: Holes in the outer metal cabinet need not be sealed if (1) there are not more than two, (2) wiring is not routed through the hole, and (3) the total area is no more than 1 inch<sup>2</sup>. For unsealed holes larger than 1 inch<sup>2</sup> the construction must be evaluated for flammability using the test method outlined in Sec. 9.5 for HF-1 material.*

4.8.1.5A Thermal insulation located between a non-metallic outer cabinet or door and an inner liner of a refrigerator need not be tested for flammability if (1) all entrance and exit holes (for wiring, foaming, and the like) located within this volume are sealed, (2) either the securement of the outer cabinet surfaces is inherent in the construction, or the maximum spacing between screws or other securement means on the outer cabinet does not exceed 152.4 mm (6 inches), (3) ignition sources (including line voltage wiring) are isolated as described in Clauses 4.8.1.4, 4.8.1.6 and 4.8.1.7, and (4) the radiant panel or Flame Spread Test, Clause 9.9, is conducted on the cabinet and/or door materials.

*Exception: Holes in the outer metal cabinet need not be sealed if (1) there are not more than two, (2) wiring is not routed through the hole, and (3) the total area is not more than 1 inch<sup>2</sup>. For unsealed holes larger than 1 inch<sup>2</sup> the construction may be evaluated for flammability using the test method outlined in Sec. 9.5 for HF-1 material.*

4.8.1.6 The tests that may be conducted are identified in Table 4.2. Table 4.3 specifies the tests applicable to the polymeric part being evaluated.

4.8.1.7 A lampholder or switch that controls only a light, or fan motor, ice maker, dispenser auger motor, anti-condensate heater, or similar load located within the confines of a food storage compartment, may be mounted on a polymeric part provided that:

- a) wiring is separated or isolated from the polymeric material (see Clause 4.8.1.4);
- b) leads are integral to the component or are provided with insulated terminations; and
- c) the switch or lampholder has no uninsulated live parts after insulated terminals are connected as judged by the requirements of assembly, Clause 4.5.

**Table 4.2 – Test summary**

1	Electrical Enclosure Flammability, Clause 9.1
2	Vertical Burning Test - 5VA, and 5VB Materials, Clause 9.2
3	Vertical Burning Test - V-0, V-1, or V-2 Materials, Clause 9.3
4	Horizontal Burning Test - HB Materials, Clause 9.4
5	Horizontal Burning Test - HBF, HF-1, or HF-2 Foamed Materials, Clause 9.5
6	Mold Stress-Relief Test, Clause 9.6
7	Fastener Strength Test, Clause 9.7
8	Adhesive Test, Clause 9.8
9	Flame Spread Test <sup>a</sup> , Clause 9.9
10	Volume Resistivity Test, Clause 9.10
11	High Current Arc Ignition Test, Clause 9.11
12	Hot Wire Ignition Test, Clause 9.12
13	Electrical Disturbance Test, Clause 9.14
14	Impact Test, Clause 8.30
<sup>a</sup> As an alternate, the radiant panel method in the Test Method for Surface Flammability of Materials Using a Radiant Heat Energy Source, ASTM E162-1998 can be employed.	

Table 4.3 – Tests on a polymeric part

Test Group	Applicable Test Number
<u>Group 1</u> A part serving as an enclosure of uninsulated live parts	1 <sup>a, m</sup> or 2 <sup>a, k</sup> , 7 <sup>e, j</sup> , 8 <sup>e</sup> , 9 <sup>f</sup> , 10 <sup>g</sup> , 11 <sup>i</sup> , 12 <sup>j</sup> , 14
<u>Group 2</u> A part serving as an enclosure of insulated live parts	1 <sup>b, c</sup> , 2 <sup>b, c</sup> , 3 <sup>b, c</sup> , 4 <sup>b, c</sup> or 5 <sup>b, c</sup> , 6 <sup>k</sup> , 7 <sup>d, j</sup> , 8 <sup>e</sup> , 9 <sup>f</sup> , 10 <sup>g</sup> , 11 <sup>h</sup> , 12 <sup>i</sup> , 14
<u>Group 3</u> A functional part	3 <sup>b, c</sup> , 4 <sup>b, c</sup> or 5 <sup>b, c</sup> , 6 <sup>k</sup> , 7 <sup>d, j</sup> , 8 <sup>e</sup> , 10 <sup>g</sup> , 11 <sup>h</sup> , 12 <sup>i</sup> , 14
<u>Group 4</u> A nonfunctional part	3 <sup>b</sup> , 4 or 5, 9 <sup>f</sup> , 13 <sup>a, b</sup>
<p><sup>a</sup> This test does not apply to a polymeric material having a 5V rating.</p> <p><sup>b</sup> This test does not apply to a polymeric material having a V-0, V-1, V-2, or 5V rating.</p> <p><sup>c</sup> If ignition sources are separated or isolated in accordance with Clause 4.8.1.4, materials having a HB, or HBF rating may be used.</p> <p><sup>d</sup> Applies only to ultrasonic welds, or heat welds; polymeric screws or nuts; metal screws threaded into a polymeric part; or other means where degradation of a polymeric material may affect securement.</p> <p><sup>e</sup> Applies only if the adhesive is relied on to maintain the integrity of an enclosure or functional part.</p> <p><sup>f</sup> Applies only to polymeric parts forming portions of the external enclosure, or of a decorative part if the total area of the polymeric enclosure exceeds 0.93 m<sup>2</sup> (10 square feet).</p> <p><sup>g</sup> Applies only if electrical spacings between uninsulated live parts and the material are less than specified in line-voltage circuits, Clause 6.1, and extra-low voltage (Class 2) circuits, Clause 6.2, or if the part is used as indirect support of an uninsulated live part.</p> <p><sup>h</sup> Applies only if the material is used to enclose uninsulated live parts or to provide indirect support of uninsulated live parts. This test need not be conducted if the uninsulated live parts are located at least 12.7 mm (1/2 inch) from the enclosure or functional part.</p> <p><sup>i</sup> Applies only if the material is within 12.7 mm (1/2 inch) of electrically-heated wires, resistors, or the like.</p> <p><sup>j</sup> Does not apply to an enclosure that serves only to reduce the risk of injury to persons.</p> <p><sup>k</sup> In the case of a cabinet liner that provides indirect support of an electrical component, the test may be waived if a metal plate having an area at least equal to the projected area of the supported component, including its mounting means, is secured to the component and to the liner. The thickness of the metal plate shall be sufficient to withstand the impact specified in Clause 8.30.3.</p> <p><sup>m</sup> An enclosure provided with a barrier interposed between the material and an ignition source will be tested with the barrier in place.</p>	

## 4.9 Field supply connections

### 4.9.1 Cord-connected refrigerators

4.9.1.1 A refrigerator intended for cord connection to an ac power supply shall be equipped with a flexible cord having an equipment grounding conductor terminating in a grounding-type attachment plug that complies with the American National Standards designated in Table 4.4.

*Exception: A refrigerator intended for connection to a circuit rated (1) other than 60 Hz, (2) other than the ac voltages specified in the first column of Table 4.4, or (3) both, may employ a grounding-type attachment plug acceptable for the circuit involved.*

4.9.1.2 The rating of the attachment plug shall be not less than 125 percent of the marked rating of the refrigerator and not less than the total input measured during the temperature and pressure test, Clause 8.6; and defrost test, Clause 8.9, whichever produces the higher input. The total input shall include all concurrent loads, including the loads drawn by accessories intended for use with the refrigerator.

**Table 4.4 – Attachment-plug rating**

Attachment plug rating amperes, volts		ANSI Designation <sup>a</sup>
15	125	5 – 15P
20	125	5 – 20P
15	250	6 – 15P

<sup>a</sup> Standard for Wiring Devices – Dimensional Requirements, ANSI/NEMA WD6-1988.

4.9.1.3 A cord-connected refrigerator shall employ Type S, SE<sup>a</sup>, SO, SOO<sup>a</sup>, ST, STO<sup>a</sup>, STOO<sup>a</sup>, SJ, SJE<sup>a</sup>, SJO, SJOO<sup>a</sup>, SJT, SJTO<sup>a</sup>, SJTOO<sup>a</sup>, SP-3<sup>a</sup>, SPE-3<sup>a</sup>, or SPT-3 power supply cord having a voltage rating not less than that of the refrigerator. The ampacity of the cord as given in Table 12 in the Canadian Electrical Code, Part I, CSA Standard C22.2-1990 and Table 400-5 in the National Electrical Code, ANSI/NFPA 70 shall not be less than that required by the ampere input measured in the temperature and pressure test, Clause 8.6, and the defrost test, Clause 8.9. The ampere input value shall include all concurrent loads including the current drawn by accessories intended for use with the refrigerator.

<sup>a</sup>Cord type included only in the National Electrical Code, ANSI/NFPA 70.

4.9.1.4 A refrigerator with swivel-type rollers or swivel-type casters may employ Type SP-3, SPE-3, or SPT-3 flexible cord only if the design prevents damage to the cord when the refrigerator is moved. Only casters provided on or with the refrigerator at the factory, or as factory-provided accessories, are considered in judging compliance with this requirement.

4.9.1.5 The length of a power supply cord shall be not less than 1.5 m (5 feet) nor more than 3.0 m (10 feet). The length shall be measured between the attachment plug and (1) any point at which the cord exits the refrigerator cabinet or (2) the last strain relief, whichever is shorter.

*Exception No. 1: The power-supply cord for a wall-hung refrigerator shall not exceed 0.6 m (2 feet) in length.*

*Exception No. 2: For built-in refrigerators the power-supply cord may be less than 1.5 m (5 feet) long provided:*

*a) the bottom of the machine compartment or condensing unit is at least 1.7 m (5.58 feet) above the floor;*

*b) the installation instructions indicate the location of the electrical outlet in the alcove for the refrigerator so as to accommodate the shorter length of power supply cord;*

*c) the unit is marked in accordance with Clause 11.1.18; and*

*d) the power supply cord can be connected and disconnected from the front without the need to move the refrigerator.*

4.9.1.6 The power supply cord shall be provided with strain relief means so that a stress on the cord will not be transmitted to terminals, splices, or internal wiring. See Clause 8.16. If the strain relief is metallic, it shall not contact uninsulated live parts or reduce electrical spacings within the enclosure if the cord is moved inward.

4.9.1.7 The edges of the entry hole for the power supply cord, including the cord entry hole in a bushing, shall be rounded and without burrs, fins, or sharp edges that might damage the cord insulation. Within the unit, the power supply cord shall be routed to reduce the risk of damage to the cord insulation.

4.9.1.8 Clamps or clips used to secure thermoplastic-insulated wires shall be nonmetallic material. Metal clamps having well rounded edges may be acceptable subject to investigation.

#### 4.9.2 DC and AC/DC units

4.9.2.1 The requirements of Clauses 4.9.2.2 – 4.9.2.4 apply to DC and AC/DC refrigerators and are in addition to the provisions of Clauses 4.9.1.1 – 4.9.1.7 and Clauses 4.9.3.1 – 4.9.3.24. AC/DC refrigerators are to be provided with two separate means for connection to the power supplies.

4.9.2.2 A refrigerator intended for cord connection to a dc power supply shall be provided with a cord and dc rated attachment plug that (1) complies with the Standard for Vehicle Battery Adapters, UL 2089, and General Use Receptacles, Attachment Plugs and Similar Wiring Devices, CSA Standard C22.2 No. 42, and (2) incorporates a fuse or other overcurrent protective device rated not in excess of the ampacity of copper conductors, as follows:

Wire size		Ampacity
mm <sup>2</sup>	AWG	
0.82	18	6
1.3	16	8
2.1	14	15

*Exception: The overcurrent protective device may be provided in the supply cord not more than 127 mm (5 inches) from the attachment plug.*



4.9.2.3 With reference to Clause 4.9.2.2, if a fuse is employed, the fuse type and rating shall be permanently marked on or adjacent to the fuseholder.

*Exception: A marking need not be included if the fuse is inaccessible to the user and if there is no reference to a fuse on the appliance or in the literature provided with the appliance.*

4.9.2.4 If an ac/dc unit can be simultaneously connected to the ac and dc power sources, the construction shall be such that disconnection from one power supply will automatically cause de-energization of all circuits within the unit.

*Exception: Automatic de-energization may be omitted if the unit is marked in accordance with Clause 11.1.19.*

#### 4.9.3 Permanently-connected refrigerators

4.9.3.1 A refrigerator intended for permanent connection to the power supply shall have provision for connection of one of the wiring systems that, in accordance with the Canadian Electrical Code, Part I, CSA Standard C22.2-1990 and the National Electrical Code, ANSI/NFPA 70-1993, would be acceptable for the appliance.

4.9.3.2 Refrigerated kitchen units shall have provision for permanent connection to the power supply.

4.9.3.3 A refrigerator intended for permanent connection to the power supply shall have as a provision for grounding an equipment grounding terminal or lead.

4.9.3.4 Sheet metal to which a wiring system is to be connected in the field shall have a thickness not less than 0.81 mm (0.032 inch) if uncoated steel, not less than 0.86 mm (0.034 inch) if galvanized steel, and not less than 1.14 mm (0.045 inch) if nonferrous.

4.9.3.5 If threads for the connection of conduit are tapped all the way through a hole in an enclosure wall, or if an equivalent construction is employed, there shall be not less than three nor more than five threads in the metal, and the construction of the device shall be such that a conduit bushing can be attached. If threads for the connection of conduit are not tapped all the way through a hole in an enclosure wall, conduit hub, or the like, there shall be not less than 3-1/2 threads in the metal, and there shall be a smooth, rounded inlet hole for the conductors that shall (1) afford protection to the conductor equivalent to that provided by a standard conduit bushing and (2) have an internal diameter approximately the same as that of the corresponding trade size of rigid conduit.

4.9.3.6 A knockout for connection of a field-wiring system to a field-wiring compartment shall accommodate not less than 12.7 mm (0.5 inch) trade size conduit.

4.9.3.7 A knockout in a sheet metal enclosure shall be secured in place, but shall be capable of being removed without deformation of the enclosure that would result in damage to electrical components or reduction in electrical spacings.

4.9.3.8 A knockout shall remain in place when a force of 44.5 N (10 pounds) is applied at right angles to the knockout by a 6.4 mm (1/4 inch) diameter mandrel with a flat end. The mandrel shall be applied at the point most likely to cause movement of the knockout.

4.9.3.9 A knockout shall be provided with a flat surrounding surface for seating of a conduit bushing and shall be located so that installation of a bushing at any knockout likely to be used during installation will not result in spacings between uninsulated live parts and the bushing of less than those required by this Standard.

4.9.3.10 In measuring the spacing between an uninsulated live part and a bushing installed in a knockout, it is to be assumed that a bushing having the dimensions indicated in Table 4.5 is in place, in conjunction with a single locknut installed on the outside of the enclosure.

**Table 4.5 – Knockout or hole sizes and dimensions of bushings**

Trade size of conduit		Nominal knockout or hole diameter		Bushing dimensions			
				Overall diameter		Height	
mm O.D.	Inches	mm	Inches	mm	Inches	mm	Inches
21.3	1/2	22.2	7/8	25.4	1	9.5	3/8
26.7	3/4	27.8	1- 3/32	31.4	1-15/64	10.7	27/64
33.4	1	34.5	1-23/64	40.5	1-19/32	13.1	33/64

4.9.3.11 The location of a terminal box or compartment in which power supply connections are to be made shall be such that these connections may be inspected after the appliance is installed. The connections shall be accessible without removing parts other than a service cover(s) or panel(s) and the cover of the outlet box or compartment in which the connections are made.

4.9.3.12 A wiring compartment intended for the connection of a supply raceway shall be secured in position and shall be prevented from turning.

4.9.3.13 The space provided at terminals or leads intended for the connection of supply conductors, or other conductors to be connected at the time of installation, shall be sufficient for acceptable installation including the accommodation of the necessary splices. An acceptable installation shall (1) be possible using ordinary tools suitable for the installation, and (2) not require installed conductors to be forced into contact with uninsulated live parts, or with noncurrent-carrying parts likely to be grounded. A trial installation may be performed to determine compliance with these requirements.

4.9.3.14 As used in Clauses 4.9.3.15 – 4.9.3.24, field-wiring terminals or leads are considered to be the terminals or leads to which power supply, control, or equipment grounding connections will be made in the field when the refrigerator is installed.

4.9.3.15 A wiring terminal shall accommodate connection of a supply conductor having an ampacity of at least 125% of the current the product will draw in accordance with the National Electrical Code, ANSI/NFPA 70-1993, and the Canadian Electrical Code, Part I, CSA Standard C22.2-1990.

4.9.3.16 A field-wiring terminal shall be secured in position by means other than friction between surfaces if turning or shifting of the terminal may result in reduction of electrical spacings below those required by line-voltage circuits, Clause 6.1, and extra-low voltage (Class 2) circuits, Clause 6.2. This may be accomplished by means such as two screws or rivets; by square shoulders or mortises; by a dowel pin, lug, or offset; or by a connecting strap or clip fitted into an adjacent part.

4.9.3.17 A wire binding screw at a field-wiring terminal shall be not smaller than 4.2 mm diameter (No. 8) except that a 3.5 mm diameter (No. 6) screw may be used for the connection of one 2.1 mm<sup>2</sup> (No. 14 AWG) or smaller conductor.

4.9.3.18 A terminal plate for a wire binding screw shall be of metal not less than 0.76 mm (0.030 inch) thick for a 2.1 mm<sup>2</sup> (No. 14 AWG) or smaller wire, and not less than 1.27 mm (0.050 inch) thick for a wire larger than 2.1 mm<sup>2</sup> (No. 14 AWG), and in either case there shall be not less than two full threads in the metal.

4.9.3.19 A terminal plate formed from stock having the minimum required thickness may have the metal extruded at the tapped hole for the binding screw to provide two full threads.

*Exception: Two full threads are not required if a lesser number of threads results in a connection in which the threads will not strip with normal tightening torque in accordance with the values indicated in the Standard for Wire Connectors and Soldering Lugs for Use With Copper Conductors, UL 486A, Wire Connectors, CSA Standard C22.2 No. 65, and Construction and Test of Soldering Lugs, CSA Standard C22.2 No. 19.*

4.9.3.20 Upturned lugs or a cupped washer shall retain a conductor of the size mentioned in Clause 4.9.3.15 under the head of the screw or the washer.

4.9.3.21 A wire binding screw shall thread into metal.

4.9.3.22 A field-wiring terminal intended for the connection of a grounded (identified) conductor shall be of a metal, or plated with a metal, that is substantially white in color and shall be readily distinguishable from other terminals, or identification of that terminal shall be shown in some other manner, such as on an attached wiring diagram. A lead intended for the connection of a grounded (identified) conductor shall be finished to show a white or natural grey color, shall be readily distinguishable from other leads, and no other lead shall be so identified.

4.9.3.23 The length of a lead inside an outlet box or wiring compartment shall be 152.4 mm (6 inches) or more if the lead is intended for field connection to an external circuit.

4.9.3.24 Leads intended for connection to the field supply conductors, including grounding conductors, shall be provided with strain relief if stress on the lead may be transmitted to terminals, splices, or internal wiring. See strain relief test, Clause 8.16.

#### 4.9.4 Grounding

4.9.4.1 A refrigerator shall have provision for grounding.

4.9.4.2 On a permanently-connected refrigerator, a terminal solely for connection of an equipment-grounding conductor shall be capable of securing a conductor of the size required in accordance with the Canadian Electrical Code, Part I, CSA Standard C22.2-1990 and the National Electrical Code, ANSI/NFPA 70-1993.

4.9.4.3 A soldering lug, a push-in connector, a screwless connector, or a quick-connect or similar friction-fit connector shall not be used for a terminal intended for the connection of a field-installed grounding conductor or for connection of the grounding wire in a power supply cord.

4.9.4.4 On a permanently-connected refrigerator, a wire binding screw intended for the connection of an equipment grounding conductor shall have a green-colored head that is hexagonal, slotted, or both, with or without a secondary means of rotation. Except as indicated in Clause 4.9.4.5, a pressure wire connector intended for connection of a grounding conductor shall be plainly identified, such as by being marked "G", "GR", "Ground", or "Grounding", by the International Electrotechnical Committee (IEC) 417, Symbol 5019 or the equivalent, or by a marking on a wiring diagram provided on the refrigerator. The wire binding screw or pressure wire connector shall be secured to the frame or enclosure of the refrigerator and shall be located so that it is not required to be removed during service operations, such as adjusting controls or oiling motors. Uprturned lugs or the equivalent shall be provided at a wire binding screw to retain the conductor.

4.9.4.5 If a pressure wire connector intended for grounding is located adjacent to connectors intended for supply conductors involving the neutral conductor of a grounded supply, it shall be identified by a marking "EQUIPMENT GROUND", by a green color, or by both.

4.9.4.6 On a permanently-connected refrigerator, the surface of an insulated lead intended solely for the connection of an equipment grounding conductor shall be finished in a continuous green color or a continuous green color with one or more yellow stripes, and no other lead shall be so identified.

4.9.4.7 On a cord-connected refrigerator, the grounding conductor of the power supply cord shall be finished with a continuous green color or with continuous green color with one or more yellow stripes, and no other conductor shall be so identified. The grounding conductor shall be secured to the frame or enclosure of the refrigerator by a positive means, such as clamping, bolting or screwed connection, that is not required to be removed during any servicing operation not involving the power supply cord. The grounding conductor shall be connected to the grounding blade of the attachment plug.

#### 4.9.5 Bonding for grounding

4.9.5.1 A refrigerator shall have provision for the grounding of all exposed or accessible noncurrent-carrying metal parts that are likely to become energized and that may be contacted by the user or by service personnel during service operations that are likely to be performed while the refrigerator is energized.

*Exception: Exposed or accessible metal parts need not comply with Clause 4.9.5.1 provided such parts are double insulated in accordance with the requirements specified in the Standard for Double Insulation Systems for Use in Electrical Equipment, UL 1097, and General Requirements for Double Insulated Equipment, CSA Standard C22.2 No. 0.1.*

4.9.5.2 Uninsulated metal parts, such as cabinets, electrical enclosures, motor frames and mounting brackets, controller mounting brackets, heater element sheaths, capacitors and other electrical components, interconnecting tubing and piping, valves and plumbing accessories, and refrigerant-containing parts are to be bonded for grounding if they may be contacted by the user or service personnel.

*Exception: The metal parts specified in Items (a) – (d) need not be grounded:*

*a) adhesive-attached metal-foil markings, screws, handles, or the like, that are located on the outside of enclosures or cabinets and isolated from electrical components or wiring by grounded metal parts so that they are not likely to become energized;*

*b) isolated metal parts, such as motor controller magnet frames and armatures or small assembly screws, that are positively separated from wiring and uninsulated live parts;*

*c) cabinets, panels, and covers that do not enclose uninsulated live parts, if wiring is positively separated from the cabinet, panel, or cover so that it is not likely to become energized; and*

*d) panels and covers that are insulated from electrical components and wiring by an insulating barrier of vulcanized fiber, varnished cloth, phenolic composition, or similar materials not less than 0.71 mm (0.028 inch) thick and secured in place. If material having a lesser thickness is used, consideration is to be given to such factors as its electrical, mechanical, and flammability properties, when compared with materials in thicknesses specified above.*

4.9.5.3 If a component, such as a compartment temperature control or defrost timer, is likely to become separated from its grounding means for purpose of testing or adjustment while the equipment is energized, it shall be provided with a grounding conductor not requiring removal for such service.

4.9.5.4 Metal-to-metal hinge bearing members for a door or cover are considered to be a means for bonding a door or cover for grounding if a multiple-bearing pin-type hinge(s) is employed.

4.9.5.5 A separate component bonding conductor shall be of copper, a copper alloy, or other material acceptable for use as an electrical conductor. Ferrous metal parts in the grounding path shall be protected against corrosion by metallic or nonmetallic coatings, such as enameling, galvanizing, or plating. A separate bonding conductor or strap shall (1) be protected from mechanical damage or be located within the confines of the outer cabinet or frame, and (2) not be secured by a removable fastener used for any purpose other than bonding for grounding unless the bonding conductor is unlikely to be omitted after removal and replacement of the fastener.

4.9.5.6 The bonding shall be by a positive means such as clamping, riveting, bolted or screwed connection, brazing, or welding. The bonding connection shall penetrate nonconductive coatings such as paint or vitreous enamel. Bonding around a resilient mount shall not depend on the clamping action of rubber or other nonmetallic material except as indicated in Clause 4.9.5.8.

4.9.5.7 With reference to Clause 4.9.5.6, a bolted or screwed connection that incorporates a star washer under the screwhead or a serrated screwhead is acceptable for penetrating nonconductive coatings. If the bonding means depends upon screw threads, two or more screws or two full threads of a single screw shall engage the metal.

4.9.5.8 If a grounding connection relies on the integrity of a polymeric part, the connection shall comply with provisions of the grounding continuity test, Clause 9.15.

4.9.5.9 An internal connection for bonding internal parts to the enclosure for grounding, but not for a field-installed grounding conductor or for the grounding wire in a supply cord, may employ a quick-connect terminal of the dimensions specified in Table 4.6, provided that the connector is not likely to be displaced.

**Table 4.6 – Quick-connect terminals**

Terminal dimensions	
mm	(Inches)
0.51 by 4.75 by 6.4	(0.020 by 0.187 by 0.250)
0.81 by 4.75 by 6.4	(0.032 by 0.187 by 0.250)
0.51 by 5.2 by 6.4	(0.020 by 0.205 by 0.250)
0.81 by 5.2 by 6.4	(0.032 by 0.205 by 0.250)
0.81 by 6.4 by 7.8	(0.032 by 0.250 by 0.307)

4.9.5.10 Except as permitted by Clauses 4.9.5.13 and 4.9.5.14, a bonding conductor or strap on a cord-connected refrigerator shall have a cross-sectional area not less than that of the grounding conductor of the supply cord.

4.9.5.11 On a permanently-connected refrigerator, the size of a conductor employed to bond an electrical enclosure or motor frame shall be based on the rating of the branch circuit overcurrent device to which the equipment will be connected. Except as permitted by Clauses 4.9.5.13 and 4.9.5.14, the size of the conductor or strap shall be in accordance with Table 4.7.

**Table 4.7 – Bonding wire conductor size**

Rating of overcurrent device amperes	Size of bonding conductor <sup>a</sup>			
	Copper		Aluminum	
	mm <sup>2</sup>	Wire AWG	mm <sup>2</sup>	Wire AWG
15	2.1	14	3.3	12
20	3.3	12	5.3	10

<sup>a</sup> Or equivalent cross-sectional area.

4.9.5.12 A conductor, such as a clamp or strap, used in place of a separate wire conductor as indicated in Clause 4.9.5.11, is acceptable provided that the minimum cross-sectional conducting area is equivalent to the wire sizes indicated in Table 4.7.

4.9.5.13 With regard to Clauses 4.9.5.10 and 4.9.5.11, a smaller conductor may be used if the bonding conductor and connection comply with the provisions of the current overload test – bonding conductors and connections, Clause 8.19, and the limited short circuit test, Clause 8.18.

4.9.5.14 A bonding conductor to a motor or other electrical component need not be larger than the size of the motor-circuit conductors or the size of the conductors supplying the component.

4.9.5.15 Splices shall not be employed in wire conductors used to bond electrical enclosures, motor frames, or other electrical components. Separable multi-pin connectors that provide for simultaneous disconnection of the current-carrying conductors and the grounding conductor may be employed.

## 4.10 Wiring and wiring methods

### 4.10.1 General

4.10.1.1 This Clause shall apply to both line-voltage circuits and extra-low voltage safety circuits, unless stated otherwise. Extra-low voltage nonsafety circuit wiring requirements are not specified.

4.10.1.2 Wiring shall have insulation rated for the potential involved and the temperatures to which it may be subjected. Compliance is to be judged on the basis of the temperatures measured during the applicable temperature tests specified in Clauses 8.6 and 8.8.

*Exception: If it can be determined that the wiring shall not be exposed to heat from radiating sources or heated components, and if the ampacity of the conductors is in accordance with Table 4.8, the temperature tests on the wiring may be waived.*

4.10.1.3 Wiring that is color-coded green or green with one or more yellow stripes shall be used only for grounding conductors. Wiring used for other purposes shall not be identified with the above color codes.

**Table 4.8 – Wiring materials ampacities**

Wire size		Ampacity
mm <sup>2</sup>	AWG	
0.41	22	4
0.66	20	7
0.82	18	10
1.3	16	13
2.1	14	18
3.3	12	25
5.3	10	30
8.4	8	40
13.3	6	55
21.2	4	70
33.6	2	95
42.4	1	110

<sup>a</sup> The ampacities shown apply to appliance wiring materials. For types of wires other than appliance wiring materials, the ampacity shall be determined from Tables 310-16 and 310-17 in the National Electrical Code, ANSI/NFPA No. 70-1993 and Tables 1 through 4 in the Canadian Electrical Code, Part I, CSA Standard C22.1-1990, for the type of wire employed. The correction factors of the referenced tables need not be applied.

4.10.1.4 If the input to a resistance type heater wire exceeds 8 W/m (2.5 W/ft), the wire is rated less than 80°C (176°F), the wires are less than 19.1 mm (3/4 inch) apart, or the wires are not in positive contact with a radiating surface, the heater shall be subjected to the heating test - condensate wiring, Clause 9.17.

4.10.1.5 The insulation of wires or cords connected to fan motors and other auxiliary motors shall be of an oil resistant type, such as Type SJO, SJT, SPT-3, or appliance wiring materials having oil resistant insulation.

4.10.1.6 If cords or appliance wiring material are employed in the user accessible refrigerated compartment, such wiring shall be of a type indicated by Table 4.9, Group B, and shall be located or protected so as not to be subjected to contact by product containers, removable shelves, or the like.

**Table 4.9 – Typical wiring**

Group	Type of wire, cord, or cable <sup>a</sup>	Wire size		Nominal insulation thickness	
		mm <sup>2</sup>	No. AWG	mm	Inch
A	Appliance wiring material having thermoplastic insulation, with nominal insulation thicknesses shown at the right corresponding to wire sizes indicated; or Type TW; or Type <sup>c</sup> AC, ACL, ACT, FFH-2, TF, TFF, TFN, TFFN, SF-2, SFF-2, RH, RHH, RHW, THW, XHHW, MTW, THW-MTW, THWN, PF, PGF, PFF, PGFF; or Type <sup>d</sup> TEW, TR-32, R90, RW90, T90, TW75, SEW-1, SEW-2, GTF.	3.3 – 0.82	10 and smaller	0.8	2/64
B	Appliance wiring material having thermoplastic or thermoset insulation, with nominal insulation thicknesses shown at right corresponding to the wire size indicated; or cord Type S, SO, SOO, ST, STO, STOO, SJO, SJOO, SJT, SJTO, SJTOO, SPT-3; or Type <sup>c</sup> SE, SJ, SJE, SP-3, SPE-3; or Type <sup>b</sup> NMD90, NMWU.	0.82	18	1.6 <sup>d</sup>	4/64 <sup>d</sup>
		1.3	16	1.6 <sup>d</sup>	4/64 <sup>d</sup>
		2.1	14	2.0 <sup>e</sup>	5/64 <sup>e</sup>
		3.3	12	2.0 <sup>e</sup>	5/64 <sup>e</sup>
C	Appliance wiring material <sup>b</sup> having rubber insulation, with insulation thicknesses shown at the right corresponding to wire sizes indicated; or cord Type S, SJ, or SP-3.	Same as for Group B			

<sup>a</sup> The designated cord or cable or types of wire other than appliance wiring material may be used without regard to the values specified in this Table.

<sup>b</sup> Wire Types included only in the Canadian Electrical Code, Part I, CSA Standard C22.1-1990.

<sup>c</sup> Wire Types included only in the National Electrical Code, ANSI/NFPA No. 70-1993.

<sup>d</sup> Total wire insulation thickness can be achieved by use of 0.8 mm (2/64 inch) insulation integral to the wire plus 0.8 mm (1/32 inch) thick supplemental sleeving, such as fiberglass, etc.

<sup>e</sup> Total wire insulation thickness can be achieved by use of 1.2 mm (3/64 inch) insulation integral to the wire plus 0.8 mm (1/32 inch) thick supplemental sleeving, such as fiberglass, etc.



4.10.1.7 If wiring extends from the cabinet to a hinged door or other part that provides access to the product storage area, flexible conductors, such as the S series of cord specified in Item B of Table 4.9 or equivalent, shall be employed. The wiring shall be routed or protected to reduce the risk of damage to the insulation. If the wiring is exposed, it shall be provided with strain relief so that stress will not be transmitted to terminals or splices. See strain relief test, Clause 8.16.

4.10.1.8 With reference to Clause 4.10.1.7, wiring that is subjected to movement is to be tested by cycling the moving part through the maximum travel permitted by the design unless it is evident that the wiring will not be damaged. The duration of the test is to be as indicated in Clause 8.28.4 and may be run in conjunction with the door latch release test, Clause 8.28. Following this, the unit is to be subjected to the dielectric voltage-withstand test, Clause 8.8, while the door is moved one time from the closed to the maximum open position. After this test the wiring is to be visually examined for damage to determine if individual strands have penetrated the insulation.

#### 4.10.2 Permanently-connected refrigerators

4.10.2.1 Except as indicated in Clauses 4.10.1.6, 4.10.1.7, and 4.10.2.2, wiring shall be of the type indicated in Group A of Table 4.9, and enclosed in conduit, electrical metallic tubing, metal raceways, control boxes, or the like. Fittings shall be constructed for use with the type of wiring enclosure employed in the application.

4.10.2.2 Cords or appliance wiring material of a type indicated in Group A or B of Table 4.9, may be employed if the wiring is enclosed by the cabinet to reduce the risk of (1) damage to the wiring, (2) ignition of flammable material, or (3) emission of flame or molten metal through openings in the cabinet. Wiring shall be separated from flammable material in accordance with Clause 4.8.1.4.

4.10.2.3 With regard to Clause 4.10.2.2, wiring shall be positively routed, isolated, or both from openings in the cabinet as follows:

- a) Openings Below Wiring – Wiring shall be located such that an opening is not located below the wiring within Space A in Figure 4.3 (that is, the space generated by a 5 degree angle) unless a barrier is placed between the wiring and the opening. The barrier does not have to be larger than the opening within the generated space.
- b) Openings Above Wiring – Wiring shall be located such that an opening is not located above the wiring within Space B in Figure 4.3 (that is, the space generated by a 30 degree angle) unless a barrier is placed between the wiring and the opening. The barrier does not have to be larger than the opening within the generated space.
- c) Openings in the Vertical Plane of the Enclosure – Wiring shall be located such that an opening in the vertical plane of the enclosure is not within 101.6 mm (4 inches) of the wiring unless a barrier is placed between the wiring and the opening.

*Exception: A finned condenser coil is acceptable as a barrier in a vertical plane if the wiring cannot be contacted by a rod 6.4 mm (1/4 inch) in diameter and 50.8 mm (2 inches) long.*

Figure 4.3 – Separation of wiring from outer enclosure openings

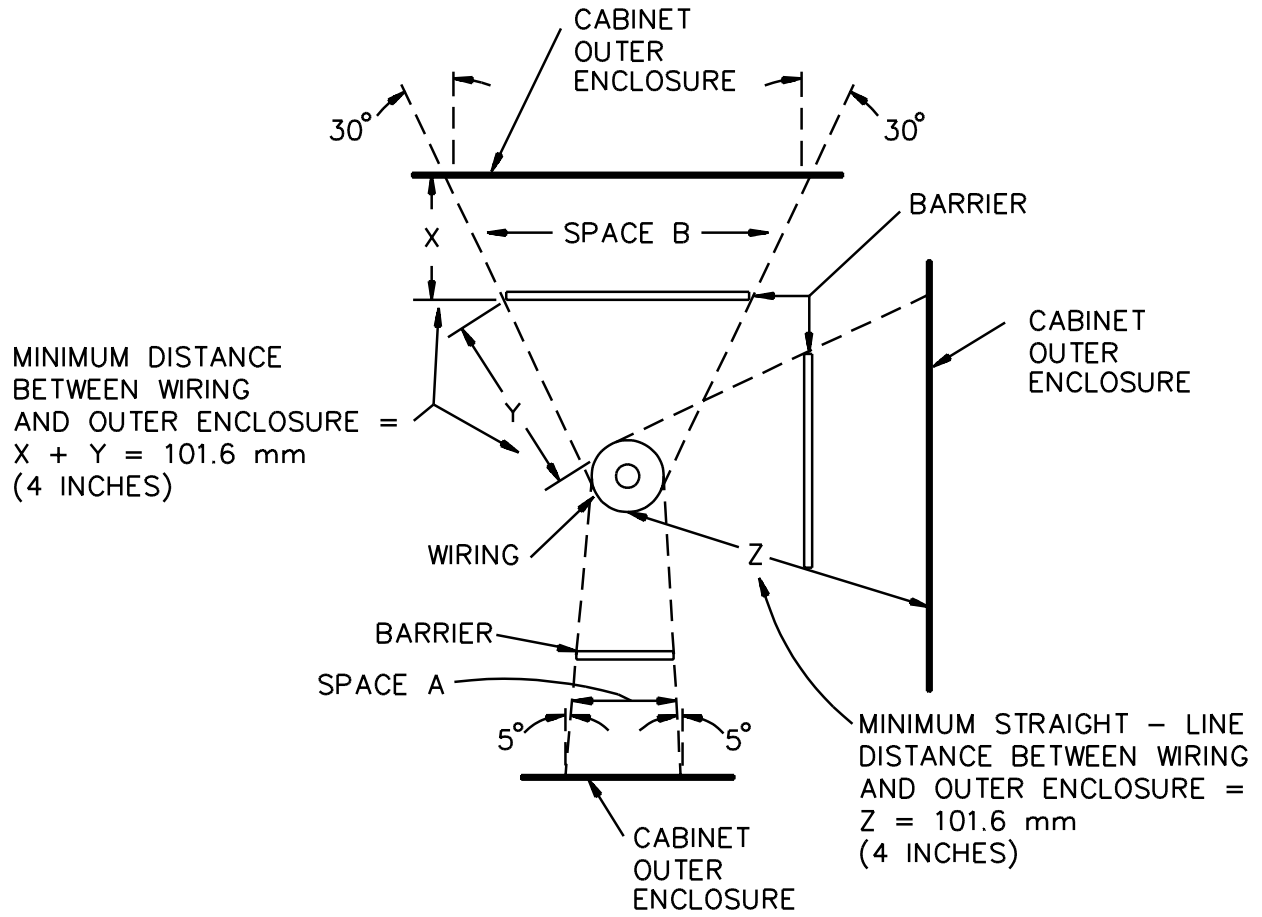

S2514B

Space A – Represents the volume below the wiring determined by a straight line that moves about the wiring while remaining at an angle of 5° from the vertical and is always oriented so that the volume is maximum.

Space B – Represents the volume above the wiring determined in the same manner as Space A, except that the angle is 30° from the vertical.

4.10.2.4 With regard to Clause 4.10.2.3, louvers or openings other than in the bottom of the wiring compartment shall not permit entrance of a rod having a diameter of 12.7 mm (1/2 inch).

4.10.2.5 A barrier required by Clause 4.10.2.3, shall be secured in place and shall be formed of (1) metal, (2) a 5V material, or (3) a material which complies with the requirements in the section for enclosure flammability – 5 inch flame test in the Standard for Polymeric Materials – Use in Electrical Equipment Evaluations, UL 746C, and Evaluation of Properties of Polymeric Materials, CSA Standard C22.2 No. 0.17.

4.10.2.6 With reference to Clause 4.10.2.2, if the compartment enclosing the wiring has no openings other than for conduit or piping and contains no flammable material other than electrical insulation, the cord or appliance wiring material referenced in Group C of Table 4.9 may be employed.

No Text on This Page

#### 4.10.3 Cord-connected refrigerators

4.10.3.1 A cord-connected refrigerator shall be wired by either of the means specified in Items (a) or (b) or by combinations of the two:

- a) cords or appliance wiring material as referenced in Group B or C of Table 4.9; or
- b) wiring material as referenced in Group A of Table 4.9, enclosed in conduit, electrical metallic tubing, metal raceways, control boxes, or cabinet walls.

*Exception: Neoprene or thermoplastic insulated wiring material in Group A of Table 4.9 need not be enclosed as indicated above, if all of the following conditions are met:*

- 1) internal wiring shall be cabled, routed, located or secured to reduce the likelihood of damage to the wiring during routine servicing such as replacing fuses, adjusting the settings of controls, or the like; and*
- 2) internal wiring shall be separated from flammable material in accordance with Clause 4.8.1.4.*

4.10.3.2 Parallel conductor appliance wiring material of the integral type shall not be ripped more than 76.2 mm (3 inches) unless the minimum wall thickness of the conductor insulation after ripping is at least 1.47 mm (0.058 inch) in thickness. If the material has conductor insulation not less than 0.71 mm (0.028 inch) after ripping and is within a separate metal enclosure, conduit, electrical metallic tubing, or metal raceway, the length of rip is not limited.

#### 4.10.4 Wiring methods

4.10.4.1 All wires and cords shall be routed and supported to reduce the risk of damage due to (1) sharp edges, (2) surfaces and parts that operate at temperatures in excess of that for which the wire insulation is rated, (3) moving parts, and (4) parts that can be expected to vibrate, such as motors, refrigerant lines, and the like. The clamping means shall have smooth, rounded surfaces.

*Exception: Wires and cords may contact a vibrating part provided that (1) the wiring is securely fastened to the part at the point of contact so as to restrict movement, (2) the part does not have burrs, fins, or sharp edges that might abrade the insulation, and (3) the vibration does not place a strain on the wiring or wiring connections.*

4.10.4.2 All wires and cords shall be routed and supported so that they will not be immersed in water unless the insulation is rated for this purpose. Wiring shall be arranged to prevent water caused by condensation from entering wiring enclosures and electrical enclosures.

4.10.4.3 A wiring enclosure shall provide a smooth wireway with no sharp edges or sharp projecting screws that might damage the wire insulation.

4.10.4.4 Holes for passage of wires or cords through walls, panels, or barriers shall have smooth, rounded surfaces or shall be provided with smoothly rounded bushings. Bushings shall be fabricated from material such as ceramic, phenolic, cold-molded composition, or fiber.

4.10.4.5 All splices and connections shall be mechanically secured and electrically bonded. A soldered connection shall be made mechanically secure before being soldered.

4.10.4.6 Splices shall be located within the unit enclosure. They shall be secured to a fixed member or located in a separate enclosure if they are subject to flexing, motion, or vibration due to air movement, or are likely to be moved during service operations, such as replacing fuses, resetting manual-reset devices, or oiling motors.

4.10.4.7 A splice shall be provided with electrical insulation equivalent to that of the conductors if permanence of spacing between the splice and other metal parts is not maintained. Thermoplastic tape wrapped over the sharp ends of the wires is not acceptable.

4.10.4.8 Splicing devices such as pressure-type wire connectors may be employed if they comply with the Standard for Wire Connectors and Soldering Lugs for Use with Copper Conductors, UL 486A, and Construction and Test of Soldering Lugs, CSA Standard C22.2 No. 19, and Wire Connectors, CSA Standard C22.2 No. 65.

4.10.4.9 Quick-connecting assemblies shall form a secure electrical connection, such as by detents in the mating parts, and shall be capable of carrying the current involved. Securement of connections may be determined by engagement/disengagement tests as specified in the Standard for Electrical Quick-Connect Terminals, UL 310, and Quick Connect Terminals, CSA Standard C22.2 No. 153.

4.10.4.10 Wire binding screws shall thread into metal. At terminals, stranded conductors shall be secured by soldered or pressure-type terminal connectors or the conductors shall be soldered or otherwise assembled to prevent loose strands after assembly. Soldered connections shall be made mechanically secure before being soldered. Open-slot type connectors shall not be used unless they prevent disconnection resulting from loosening of the clamping means. The shanks of terminal connectors shall be protected by electrical insulation if spacings may be reduced below the minimum acceptable values by loosening of the clamping means. The insulating material shall be secured in position. The thickness of the insulation on the shanks shall be not less than 0.71 mm (0.028 inch) except as permitted by Clause 6.1.6.

#### **4.11 Secondary circuits**

##### 4.11.1 General

4.11.1.1 Each secondary circuit is to be judged by the requirements for line-voltage circuits.

*Exception: A secondary circuit need not be investigated if:*

*a) it is not a circuit that is relied upon to reduce a risk of fire, electric shock, or injury to persons; and*

*b) it complies with the requirements for an extra-low voltage secondary circuit, as described in Clauses 4.11.2.1 – 4.11.2.7.*

4.11.1.2 A secondary circuit shall not be connected to the frame of the product at more than one point.

*Exception: A grounding bus of the necessary ampacity that is used as the return for a secondary circuit may be connected to the frame at more than one point.*

4.11.1.3 The frame may be used as the return for an extra-low voltage circuit.

#### 4.11.2 Extra-low voltage circuits

4.11.2.1 An extra-low voltage circuit shall be supplied from:

a) a Class 2 transformer; or

b) an isolating transformer having an open-circuit sinusoidal potential of 42.4 V peak (30 V rms) or less, and that includes at least one of the following means that limits the power available to the levels specified for a Class 2 transformer:

1) a fixed impedance;

2) a noninterchangeable fuse - the largest fuse that fits in the fuseholder provided - or a marking for fuse replacement adjacent to the fuseholder in accordance with Clause 11.1.5;

3) a nonadjustable manually reset circuit protector; or

4) a regulating network.

4.11.2.2 With reference to subitems (1) and (4) of Clause 4.11.2.1(b), if the performance of a fixed impedance or regulating network may be adversely affected by the short circuit or open circuit of any single component in the network, the likelihood of such malfunction occurring shall be determined by investigation of that component.

4.11.2.3 The impedance, the fuse, the protector, or the regulating network, and the wiring between it and the isolating transformer mentioned in Clause 4.11.2.1, shall be judged as if it were part of a line-voltage circuit.

4.11.2.4 A fuse or a circuit protector used to limit the power as specified in Clause 4.11.2.1 shall be rated or set at not more than 100 VA, where V is the open-circuit voltage, for a circuit operating between 20 and 30 V, and at not more than 5.0 A for a circuit operating at 20 V or less.

4.11.2.5 An impedance or a regulating network used to limit the power in accordance with Clause 4.11.2.1, shall limit the current under short-circuit conditions to not more than 8.0 A measured after 2 minutes.

4.11.2.6 The performance of a regulating network used to limit the power in accordance with Clause 4.11.2.1, shall not be adversely affected by either short circuit or open circuit between any two terminals of any single rectifier, capacitor, transistor, or similar component in the network.

4.11.2.7 Wires and cables that are part of an extra-low voltage circuit shall be provided with strain relief if stress on the wire or cable would cause the internal wiring of the circuits to contact an uninsulated live part of another circuit.

#### 4.12 Separation of circuits

4.12.1 Unless provided with insulation rated for the maximum required voltage of any conductor involved, insulated conductors of different circuits (internal wiring including wires in a wiring compartment) shall be separated by barriers or shall be segregated; and shall, in any case, be so separated or segregated from uninsulated live parts connected to different circuits.

4.12.2 Segregation of insulated conductors may be accomplished by clamping, routing, or other means that assures permanent separation from insulated or uninsulated live parts of a different circuit.

4.12.3 Field-installed conductors of any circuit shall be segregated or separated by barriers from field- and factory-installed conductors connected to any other circuit unless the conductors of both circuits are or will be insulated for the maximum voltage of either circuit.

4.12.4 Field-installed conductors of a line-voltage circuit or a extra-low voltage circuit with National Electrical Code, ANSI/NFPA 70-1993, or Canadian Electrical Code, Part I, CSA Standard C22.2-1990 Class 1 wiring shall be segregated or separated by barriers as specified in Items (a) and (b):

- a) from uninsulated live parts connected to a different circuit, other than wiring terminals; and
- b) from any uninsulated live parts, except at wiring terminals of electrical components such as a pressure-limiting device, motor overload protective device, or other protective device, where short-circuiting or grounding may result in a risk of fire, electric shock, or injury to persons.

4.12.5 Field-installed conductors of a extra-low voltage circuit with National Electrical Code, ANSI/NFPA 70-1993, or Canadian Electrical Code, Part I, CSA Standard C22.2-1990 Class 2 wiring shall be segregated or separated by barriers as specified in Items (a) and (b):

- a) from uninsulated live parts connected to a line-voltage circuit; and
- b) from wiring terminals and any other uninsulated live parts of extra-low voltage electrical components such as a pressure-limiting device, motor overload protective device, where short-circuiting or grounding may result in a risk of fire, electric shock, or injury to persons.

4.12.6 If a barrier is used to provide separation between the wiring of different circuits, it shall be of metal or of a rigid insulating material secured in place.

## 5 Electrical Components

### 5.1 Capacitor

5.1.1 A motor starting or running capacitor shall be housed within an enclosure or container that will protect the plates against mechanical damage and that will reduce the risk of emission of flame or molten material resulting from malfunction of the capacitor. The container shall be of metal providing the strength and protection not less than that of uncoated steel having a thickness of 0.51 mm (0.020 inch).

*Exception: The individual container of a capacitor may be of sheet metal having a thickness less than that mentioned above or may be of material other than metal if the capacitor is mounted within the enclosure of the refrigerator or within an enclosure that houses other parts of the refrigerator.*

5.1.2 If the container of an electrolytic capacitor is metal, the container shall be considered as a live part and shall be provided with moisture-resistant electrical insulation to isolate it from dead metal parts and to prevent contact during servicing operations. The insulating material shall be not less than 0.71 mm (0.028 inch) thick except as indicated in Clause 6.1.6.



5.1.3 A capacitor employing a combustible liquid dielectric medium shall be protected against expulsion of the dielectric medium when tested in accordance with the applicable performance requirements of this Standard, including faulted overcurrent conditions based on the circuit in which it is used. See limited short circuit test, Clause 8.18.

*Exception: If the available fault current is limited by other components in the circuit, such as a motor start winding, the capacitor may be tested using a fault current less than the value specified in Table 8.3 but not less than the current established by dividing the circuit voltage by the impedance of the other component(s).*

5.1.4 Capacitors intended for connection directly across the line shall comply with the requirements of the Standard for Across-the-Line, Antenna-Coupling and Line-by-Pass Capacitors, for Radio- and Television-Type Appliances, UL 1414, and the Standard for Radio, Television, and Electronic Apparatus, CSA Standard C22.2 No. 1.

## **5.2 Current-carrying parts**

5.2.1 All current-carrying parts shall be of silver, copper, a copper alloy, or other material acceptable for use as an electrical conductor.

*Exception: Multimetallic thermal elements and heater elements of a thermal protector need not be inherently resistant to corrosion.*

5.2.2 Aluminum may be used as a current-carrying part if investigated and found to be treated to resist oxidation and corrosion.

5.2.3 Ferrous metal parts provided with a corrosion-resistant coating or stainless steel may be used for a current-carrying part (1) if permitted by Clause 3.1.1 or (2) within a motor; but the use of ferrous materials not inherently protected or provided with a corrosion-resistant coating for current-carrying parts elsewhere in the refrigerator is not acceptable.

## **5.3 Defrost heaters**

### **5.3.1 Heater elements**

5.3.1.1 An electric defrost heater shall be an encased assembly constructed of materials that will not be damaged by the temperature to which they will be subjected in the refrigerator.

5.3.1.2 Metal tubing forming a heater element enclosure shall be constructed of corrosion resistant material or shall be plated, dipped, or coated to resist external corrosion, and shall be acceptable for the temperatures to which it is subjected. See Clause 5.3.1.4.

5.3.1.3 A heater element, as installed in the complete refrigerator, shall be protected against mechanical damage. The heater is considered to be protected if it (1) employs a copper or steel sheath that is at least 0.41 mm (0.016 inch) thick, or (2) cannot be contacted when the probe illustrated in Figure 4.2 is inserted through openings in the enclosure with a force of 22.3 N (5 pounds).

5.3.1.4 Uncoated copper tubing may be employed for temperatures of 200°C (392°F) and lower; metallic coated copper tubing is acceptable for temperatures below the melting temperature of the coating. Uncoated or oxide-coated steel tubing is not acceptable as a heater sheath. Plated steel tubing may be employed if the coating is determined to be corrosion resistant and will withstand the temperatures to which it may be subjected. Aluminum tubing may be employed if the alloy withstands the defrost heater burnout test, Clause 8.10, without melting or other failure. Stainless steel tubing of the austenitic grades, such as ASTM Type 304, is generally acceptable for defrost heater sheaths.

5.3.1.5 Insulating materials, such as washers and bushings, that are integral parts of a heating element shall be of a moisture resistant material that will not be damaged by the temperatures to which they will be subjected in the refrigerator.

5.3.1.6 Insulating material employed in a heating element shall be acceptable as the sole support of live parts. Materials such as magnesium oxide may be used in conjunction with other insulating materials if located and protected so that mechanical damage is prevented and if not subjected to the absorption of moisture.

5.3.1.7 A terminal seal or heater case of rubber, neoprene, or thermoplastic material shall have acceptable aging properties for temperatures measured during heating tests. See accelerated aging test – electric heaters, Clause 8.22.

5.3.1.8 A sheath-type heater employing magnesium oxide or other moisture-absorbent insulating material shall be sealed to prevent entrance of defrost water. See insulation resistance test, Clause 8.21. Molded seal caps, vulcanized to the heater leads and heater sheath, shall have a wall thickness equivalent to that required for the heater leads.

5.3.1.9 Glass-encased heaters shall be designed and installed so that defrost water will not enter the envelope.

### 5.3.2 Defrost heater overtemperature control

5.3.2.1 If malfunction could result in a risk of fire or electric shock, a defrost heater in a refrigerator shall be provided with a temperature-limiting control. See defrost heater burnout test, Clause 8.10.

## 5.4 Guarding of lamps

5.4.1 A lamp employed in a refrigerator shall be installed or guarded so that it is not likely to be broken by material being stored in the refrigerator.

5.4.2 The surface of a lamp shall not be contacted when a 19.1 mm (3/4 inch) diameter, 76.2 mm (3 inch) long rod, supported vertically in the compartment, is moved horizontally toward the rear of the compartment at any elevation. Additionally, if a lamp is mounted in a back wall, the lamp surfaces shall not be contacted by the test rod when the rod is moved from side to side as well as from front to back.

*Exception No. 1: : If a lamp is mounted in the top surface of the compartment, it is considered to be guarded (1) if a fixed part of the refrigerator, located between the lamp and the door and not more than 38.1 mm (1-1/2 inches) from the closest surface of the lamp, extends beyond the lowest portion of the lamp or (2) if more than one-half of the cylindrical or spherical surface of a lamp is recessed above the plane of the top of the compartment, and the remaining lamp surface portion projects no more than 19.1 mm (3/4 inch) below the plane of the top.*

*Exception No. 2: : If a lamp is mounted in a side wall of the compartment, it is considered to be guarded if a fixed part of the refrigerator, located between the lamp and the door and not more than 38.1 mm (1-1/2 inches) from the closest surface of the lamp, extends beyond the projected exposed area of the lamp.*

5.4.3 A lamp guard shall not be supported by the lamp.

5.4.4 If a guard must be employed in order for a lamp to be protected in accordance with Clause 5.4.1, the guard shall sustain an impact of 1.0 J (0.75 foot-pound). The impact energy is to be imposed by a 50.8 mm (2 inch) diameter, 0.53 kg (1.18 pound-mass) steel ball, either falling vertically or by swinging as a pendulum. The lamp guard is to be mounted in its intended position and struck within 25.4 mm (1 inch) of its center. The guard shall not be damaged to the extent that the lamp is no longer protected in accordance with Clause 5.4.1.

## **5.5 Incandescent lighting systems**

5.5.1 No part of a screw-shell lampholder shall operate at a potential of more than 150 V between conductors or to ground.

*Exception No. 1: A lampholder for a pilot light or indicating lamp requiring the use of tools for replacement need not comply with this requirement.*

*Exception No. 2: This requirement does not apply to a screw-shell lampholder in a refrigerator intended for connection to an ac circuit rated (1) other than 60 Hz, (2) other than the ac voltages specified in the first column of Table 8.1, or (3) both. See Clauses 11.1.22 – 11.1.24.*

5.5.2 A lampholder with a screw-shell base shall be wired so that the screw-shell will be connected to the grounded (identified) conductor of the power supply circuit.

5.5.3 A lampholder shall be constructed so that uninsulated live parts, other than the lamp contacts, will not be exposed to contact by persons removing or replacing lamps.

## **5.6 Insulating material**

5.6.1 Material for the mounting of uninsulated live parts shall be of moisture-resistant material such as porcelain, phenolic, or cold-molded composition, or other materials that comply with the volume resistivity test, Clause 9.10, and the requirements for materials used as direct support of live parts, Polymeric Materials – Use in Electrical Equipment Evaluations, UL 746C, and Evaluation of Properties of Polymeric Materials, CSA Standard C22.2 No. 0.17.

5.6.2 Vulcanized fiber may be used for insulating bushings, washers, separators, and barriers, but not as the sole support for uninsulated live parts where shrinkage, current leakage, or warpage may result in a risk of fire or electric shock.

## 5.7 Motors and motor overload protection

5.7.1 All motors shall be protected against overload by thermal or overcurrent protective devices.

*Exception: Direct-drive motors employing impedance protection and that comply with the locked-rotor requirements specified in the Standard for Overheating Protection for Motors, UL 2111, and Motors and Generators, CSA Standard C22.2 No. 100, may be used if it is determined that the motor will not overheat under conditions of use.*

5.7.2 For a motor other than a hermetic refrigerant motor-compressor, overload protection is obtained if the protection is provided by a separate overcurrent device that is responsive to motor current and is rated or set to trip at no more than the percentage of the motor nameplate full-load current rating shown in Table 5.1.

**Table 5.1 – Protective device activation level**

	Maximum percentage protection
Motor with a marked service factor no less than 1.15	125
Motor with a marked temperature rise no more than 40°C (104°F)	125
Any other motor	115

5.7.3 A hermetic refrigerant motor-compressor complies with the requirement of Clause 5.7.1 if the protection complies with Item (a), (b), (c), or (d) below:

- a) a separate overload relay that is responsive to motor-compressor current and will trip at no more than 140 percent of the rated-load current of the motor-compressor;
- b) a thermal protector integral with the motor-compressor that complies with the Standard for Hermetic Refrigerant Motor-Compressors, UL 984/CAN/CSA-C22.2 No. 140.2;
- c) a fuse or circuit breaker responding to motor current, and rated at no more than 125 percent of the rated-load current of the motor-compressor. The refrigerator shall start and operate as intended with the fuse or circuit breaker provided; or
- d) a protective system that complies with the Standard for Hermetic Refrigerant Motor-Compressors, UL 984/CAN/CSA-C22.2 No. 140.2.

5.7.4 The rated-load current of the motor-compressor is the current drawn by the motor-compressor during the temperature and pressure test, Clause 8.6.

5.7.5 Thermal protective devices used with nonhermetic motors shall comply with the Standard for Overheating Protection for Motors, UL 2111, and the Standard for Motors with Inherent Overheating Protection, CSA Standard C22.2 No. 77.

*Exception: Motors, such as direct-drive fan motors, that are not subjected to running overloads and that are determined to be protected against overheating due to locked-rotor current by a thermal or overcurrent protective device, may be accepted under this requirement provided that it is determined that the motor will not overheat under conditions of use.*

5.7.6 Fuses shall not be used as motor overload protective devices unless the motor is protected, in accordance with Clause 5.7.2 or Clause 5.7.3(c), by the largest size fuse that can be inserted in the fuseholder.

5.7.7 Overcurrent protective devices and thermal protective devices for motors shall comply with applicable short-circuit requirements for the class of protective device and shall, in addition, comply with the requirements of the limited short circuit test, Clause 8.18.

5.7.8 Nonhermetic motors shall comply with the Standard for Electric Motors, UL 1004, and the Standard for Motors and Generators, CSA Standard C22.2 No. 100. Hermetic motor-compressors shall comply with the Standard for Hermetic Refrigerant Motor-Compressors, UL 984/CAN/CSA-C22.2 No. 140.2.

5.7.9 Motors having openings in the enclosure or frame shall be arranged to prevent particles from falling out of the motor onto flammable material within or under the unit.

5.7.10 The requirement in Clause 5.7.9 will necessitate the use of a barrier of metal, 5V material under an open-type motor unless:

- a) the structural parts of the motor or of the refrigerator, such as the bottom closure, provide the equivalent of such a barrier;
- b) the motor overload protective device provided with a motor is such that no burning insulation or molten material falls to the surface that supports the refrigerator when the motor is energized under each of the fault conditions specified in subitems (1) – (4), applicable to the motor type:
  - 1) open main winding;
  - 2) open starting winding;
  - 3) starting switch short-circuited;
  - 4) capacitor shorted (permanent split capacitor type);
- c) the motor is provided with a thermal protector (a protective device that is sensitive to temperature and current) that will prevent the temperature of the motor windings from becoming more than 125°C (257°F) under the maximum load under which the motor will run without causing the protector to cycle and from becoming more than 150°C (302°F) with the rotor of the motor locked; or
- d) the motor is tested in accordance with the requirements of the burnout test – impedance protected motors, Clause 9.13.

5.7.11 The barrier mentioned in Clause 5.7.10 shall be horizontal, shall be located as indicated in Figure 5.1, and shall have an area not less than that described in that illustration. Openings for drainage, ventilation, or the like, may be employed in the barrier provided that such openings would not permit molten metal, burning insulation, or the like, to fall on flammable material.

Figure 5.1 – Location and extent of barrier

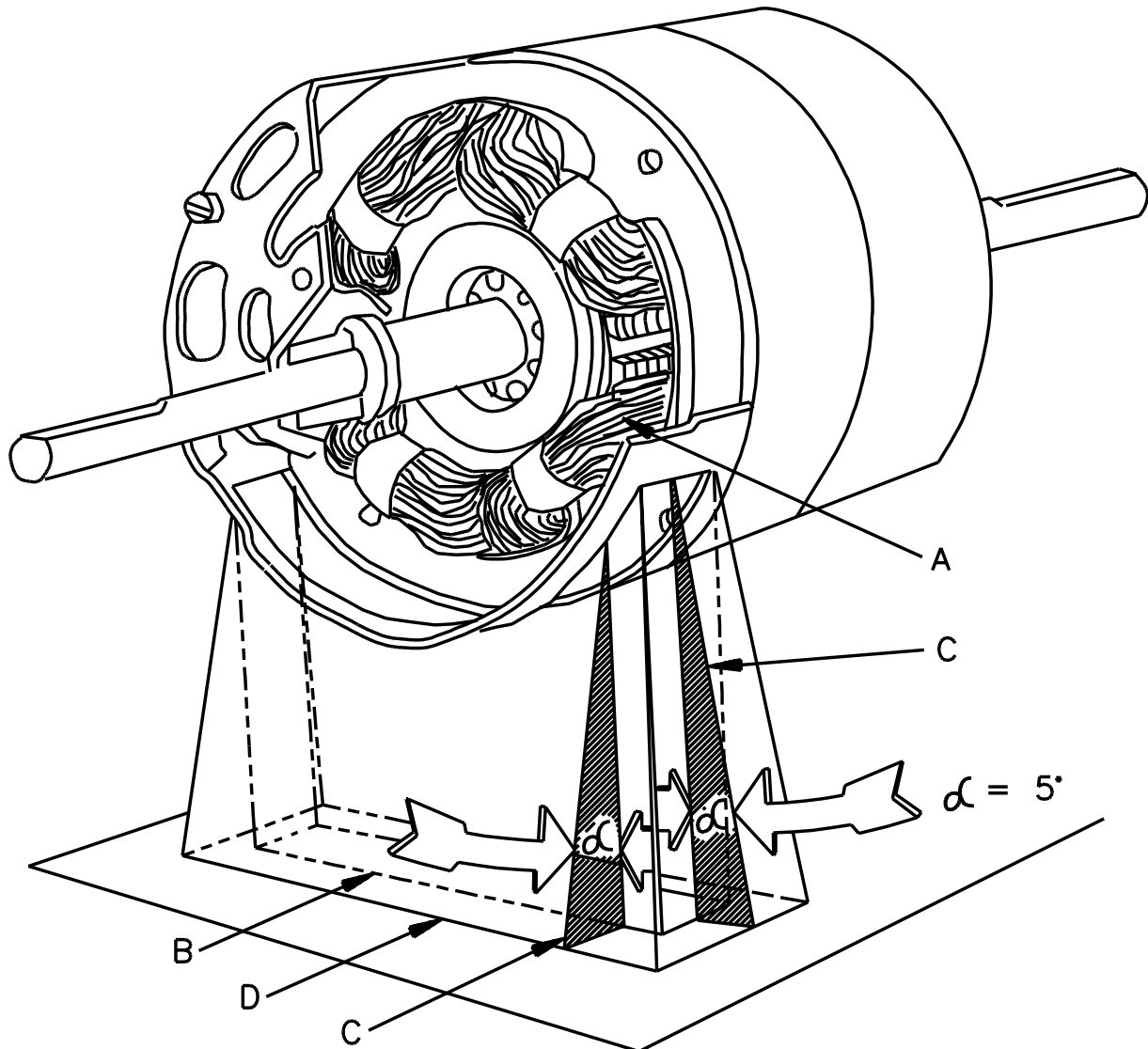
**EB100B**

A – A motor winding to be shielded by barrier. This is to consist of the entire motor winding if it is not otherwise shielded, and is to consist of the unshielded portion of a motor winding which is partially shielded by the motor enclosure or equivalent.

B – Projection of outline of motor winding on horizontal plane.

C – Inclined line which traces out minimum area of the barrier. When moving, the line is to be always (1) tangent to the motor winding, (2) 5 degrees from the vertical, and (3) so oriented that the area traced out on a horizontal plane is maximum.

D – Location (horizontal) and minimum area for barrier. The area is to be that included inside the line of intersection traced out by the inclined line C and the horizontal plane of the barrier.

## 5.8 Switches and controllers

5.8.1 A cord-connected refrigerator shall be provided with a manually-operable controller that will de-energize (1) all loads or (2) any motor load exceeding 120 V or 7.2 A. Such a controller shall have a marked OFF position (the use of the international symbol "O" may be used), and, if the controller does not de-energize all loads, the refrigerator shall be marked to indicate which loads are controlled. The controller shall be accessible without the use of tools and shall disconnect all ungrounded conductors.

*Exception No. 1: The attachment plug and receptacle may serve as the controller if the rating of the unit or motor load does not exceed 120 V or 7.2 A.*

*Exception No. 2: A thermostat (cold control) having a marked OFF position need not de-energize small loads such as an interior light, an ice maker, a water dispenser, or the like, nor be marked to indicate the load controlled if the rating of the unit does not exceed 120 V or 7.2 A.*

No Text on This Page



5.8.2 A manually operated switch with a marked off position that controls a hermetic refrigerant motor-compressor with or without other loads shall have a current rating that is at least 115 percent of the sum of (1) the motor-compressor's rated load current and (2) the rated current for other controlled loads. See Clause 5.7.4.

5.8.3 A switch or other control device shall be rated for the load that it controls as determined by the temperature and pressure test, Clause 8.6, and the defrost test, Clause 8.9.

5.8.4 The ampacity of a switch that controls an inductive load (other than a motor) such as a transformer or solenoid, shall be not less than twice the controlled load.

*Exception: An ac general-use snap switch may be used to control an inductive load not exceeding the ampere rating of the switch at rated voltage.*

5.8.5 A switch that controls a motor of other than the clock-motor type shall have a horsepower or an equivalent locked rotor ampere rating not less than that of the motor to be controlled.

*Exception: An ac general-use snap switch (not an ac-dc general-use snap switch) may be used to control a motor load not exceeding 80 percent of the ampere rating of the switch at its rated voltage.*

5.8.6 If a switching device controls a compressor motor and fan motor and/or other load, it shall have a current interrupting capacity not less than the locked-rotor load of the compressor motor plus the full load current of the fan motor and/or other load.

5.8.7 A device that controls an incandescent lamp or lamps shall be rated for the control of tungsten-filament lamps.

*Exception No. 1: A snap switch may be used to control a single intermediate, candelabra, or miniature-base lamp if the switch is rated not less than 6 A, 125 V for a nominal 120 V circuit or 3 A, 250 V for a nominal 240 V circuit.*

*Exception No. 2: An ac general-use snap switch may be used to control tungsten-filament lamp loads not exceeding the ampere rating of the switch at 120 V.*

5.8.8 A switch provided as an interlock referred to in Clauses 4.3.1 and 4.4.1 shall be endurance tested for 100,000 cycles of operation at not less than the load it controls. The tests shall be conducted as specified in either the Standards for Special-Use Switches, UL 1054, and Special-Use Switches, CSA Standard C22.2 No. 55, or the Standards for Temperature-Indicating and -Regulating Equipment, UL 873, and Temperature-Indicating and -Regulating Equipment, CSA Standard C22.2 No. 24, as applicable.

5.8.9 A switch acting as a safety control, such as a temperature-limiting control or an overcurrent protecting device of the single-pole type, shall be electrically connected to the ungrounded conductor of the supply circuit.

5.8.10 Switching devices shall be housed within an enclosure that will protect coils and contacts against mechanical damage, dirt, and moisture. The enclosure of the switching device may be provided by its method of mounting within the refrigerator enclosure, by inherent construction of the component, or by means of a separate enclosure.

## 5.9 Transformers, power converters, and power inverters

5.9.1 A transformer that directly supplies a National Electrical Code, ANSI/NFPA 70-1993, or Canadian Electrical Code, Part I, CSA Standard C22.2-1990 Class 2 circuit (see Clause 2.7) shall, in accordance with the Standard for Class 2 and Class 3 Transformers, UL 1585, and Power Supplies with Extra-Low-Voltage Class Outputs, CSA Standard C22.2 No. 223, either limit the output current (an inherently limited transformer) or be equipped with an overcurrent protection device (a not inherently limited transformer).

5.9.2 A power converter shall comply with the applicable requirements for Power Converters and Power-Converter Systems for Recreational Vehicles, UL 458, Recreational Vehicles, CSA Z240 RV Series M86, and Commercial and Industrial Power Supplies, CSA Standard C22.2 No. 107.1. See Clause 3.1.1.

5.9.3 A power inverter shall comply with the applicable requirements specified in the Standard for Power Units Other Than Class 2, UL 1012, and Safety of Component Power Supplies, CSA Standard C22.2 No. 234. See Clause 3.1.1.

## 6 Electrical Spacings

### 6.1 Line-voltage circuits

6.1.1 The electrical spacing requirements specified in Clauses 6.1.2 – 6.1.6 apply to line-voltage circuits, as defined in Clause 2.8.

*Exception: These requirements do not apply to the inherent spacings of a component part of the refrigerator, such as a hermetic refrigerant motor-compressor, motor, snap switch, controller, attachment plug, and the like, for which spacing requirements are given in a Standard for the component. However, the electrical clearance resulting from the assembly of the components into the complete machine, including clearance to dead metal or enclosures, shall be those indicated.*

6.1.2 Unless specifically noted otherwise, the spacings between uninsulated live parts of opposite polarity and between an uninsulated live part and a dead metal part shall be not less than the values indicated in Table 6.1.

**Table 6.1 – Electrical spacings in refrigerated and/or air-handling compartments**

Ratings		Minimum spacing in mm (Inches)				
Volt-amperes	Volts	Through air <sup>a</sup>		Over surface <sup>c</sup>		To enclosure <sup>c</sup>
2000 or less	300 or less	3.2	(1/8 <sup>b</sup> )	6.4	(1/4)	6.4 (1/4)
	301 – 600	9.5	(3/8)	12.7	(1/2)	12.7 (1/2)
More than 2000	150 or less	3.2	(1/8 <sup>b</sup> )	6.4	(1/4)	12.7 (1/2)
	151 – 300	6.4	(1/4)	9.5	(3/8)	12.7 (1/2)
	301 – 600	9.5	(3/8)	12.7	(1/2)	12.7 (1/2)

Note: Also includes non-air handling and/or non-refrigerated compartments that are either not-totally enclosed or subject to moisture.

<sup>a</sup> At points other than field-wiring terminals, the spacings for heater elements only may be as indicated below provided the elements are not subject to moisture, such as may result from condensation on cooled surfaces:

1.6 mm (1/16 inch) Through Air and Over Surface for heaters rated 0–300 volts.

6.4 mm (1/4 inch) Through Air and Over Surface for heaters rated 301–600 volts.

<sup>b</sup> The spacings between wiring terminals of opposite polarity or between a wiring terminal and ground shall be not less than 6.4 mm (1/4 inch), except that if short-circuiting or grounding of such terminals will not result from projecting strands of wire, spacing need not be greater than that given in the above Table, Wiring terminals are those connected in the field and not factory wired.

<sup>c</sup> Includes fittings for conduit or metal-clad cable.

6.1.3 The “Through Air” and “Over Surface” spacings at an individual component part are to be based on the total volt-ampere consumption of the load or loads that the component controls. For example, spacings at a component that controls only the compressor motor are based on the volt-amperes of the compressor motor. Spacings at a component that simultaneously controls several concurrent loads are based on the sum of the volt-amperes of the loads so controlled. Spacings at a component that controls several nonconcurrent loads are based on the volt-amperes of the largest load. The volt-ampere values for the loads referred to above are to be determined by the marked rating of the loads, except that for loads which are not required to have a marked rating, the measured inputs are to be used in determining the volt-ampere values.

6.1.3.1 With reference to 6.1.2 and 6.1.3, the spacings To Enclosure are not to be applied to an individual enclosure of a component part within an outer enclosure or cabinet.

6.1.3.2 The spacings indicated in Table 6.2 are applicable only to electrical components mounted in totally enclosed nonrefrigerated and/or non air handling compartments which are free of moisture, including that caused by condensation. At wiring terminals and for circuits over 250 volts or over 2000 volt-amperes, spacings in Table 6.1 apply.

**Table 6.2 – Spacings in non-refrigerated and/or non-air handling compartments**

Ratings		Minimum spacing in mm (inches)					
Volt-amperes	Volts	Through air		Over surface		To enclosure <sup>a</sup>	
2000 or less	125 or less	1.6	(1/16)	1.6	(1/16)	6.4	(1/4)
	126 – 250	2.4	(3/32)	2.4	(3/32)	6.4	(1/4)

NOTE – See 6.1.3.2.

<sup>a</sup> Includes fittings for conduit or metal-clad cable.

6.1.4 All uninsulated live parts connected to different circuits shall be spaced from one another as though they were parts of opposite polarity in accordance with the requirements indicated in Clause 6.1.2 and shall be based on the highest voltage involved.

6.1.5 If higher than rated potential is developed in a motor circuit through the use of capacitors, the rated voltage of the system shall be employed in applying the spacings indicated in this Clause.

*Exception: If the developed steady-state potential as determined in the temperature and pressure test, Clause 8.6, exceeds 500 V, the developed potential is to be used in determining spacings for the parts affected.*

6.1.6 An insulating liner or barrier of fiber or similar material, employed where spacings would otherwise be less than the required values, shall be no less than 0.71 mm (0.028 inch) thick and shall be so located or of such material that it will not be subject to deterioration as a result of arcing.

*Exception No. 1: Fiber no less than 0.3 mm (0.013 inch) thick may be used in conjunction with an air spacing of no less than 50 percent of the spacing required for air alone.*

*Exception No. 2: Material having a lesser thickness may be used if it has equivalent insulating, mechanical, and flammability properties when compared with materials in thicknesses specified above.*

6.1.7 The spacing between uninsulated live terminals of the components in a fluorescent electric-discharge lamp circuit and a dead metal part or enclosure shall be not less than 12.7 mm (1/2 inch) if the potential is 600 volts or less and not less than 19.1 mm (3/4 inch) if the potential is 601 – 1000 volts.

## 6.2 Extra-low voltage (Class 2) circuits

6.2.1 The electrical spacing requirements specified in Clauses 6.2.3 and 6.2.4 apply to extra-low voltage (Class 2) circuits, as defined in Clause 2.7.

6.2.2 A circuit derived from a source of supply classified as a line-voltage circuit, by connecting resistance in series with the supply circuit as a means of limiting the voltage and current, is not considered to be an extra-low voltage (Class 2) circuit.

6.2.3 The spacings for extra-low voltage (Class 2) electrical components that are installed in a circuit that includes a pressure-limiting device, motor overload protective device, or other protective device, where a short or grounded circuit may result in a risk of fire, electric shock, or injury to persons, shall comply with Items (a) – (c):

- a) the spacing between an uninsulated live part and the wall of an outer metal enclosure, including fittings for the connection of conduit or metal-clad cable, shall be not less than 3.2 mm (1/8 inch);

b) the spacing between wiring terminals regardless of polarity and between the wiring terminal and a dead metal part, including the enclosure and fittings for the connection of conduit, that may be grounded when the device is installed, shall be not less than 6.4 mm (1/4 inch); and

c) the spacing between uninsulated live parts regardless of polarity and between an uninsulated live part and a dead metal part, other than the enclosure, that may be grounded when the device is installed, shall be not less than 0.8 mm (1/32 inch) provided that the construction of the parts is such that spacings will be maintained.

6.2.4 The spacings in extra-low voltage (Class 2) circuits that do not contain devices of the type indicated in Clause 6.2.3 are not specified.

## **7 Refrigeration System**

### **7.1 Refrigerant**

7.1.1 The kind and quantity of refrigerant employed in the system shall comply with the Safety Code for Mechanical Refrigeration, ANSI/ASHRAE 15-1989, and the Mechanical Refrigeration Code, CSA B52-92.

### **7.2 Refrigerant tubing and fittings**

7.2.1 Copper or steel tubing used to connect refrigerant-containing components shall have a wall thickness not less than indicated in Table 7.1.

*Exception: Capillary tubing that is protected against mechanical damage by the cabinet or assembly may have a wall thickness not less than 0.51 mm (0.020 inch).*

No Text on This Page

**Table 7.1 – Minimum wall thickness<sup>a</sup> for copper, steel, and aluminum tubing**

Outside Diameter		Copper				Steel		Aluminum	
		Protected <sup>b</sup>		Unprotected		Protected or Unprotected			
mm	(Inches)	mm	(Inches)	mm	(Inches)	mm	(Inches)	mm	(Inches)
4.76	(3/16)	0.622	(0.0245)	0.673	(0.0265)	0.64	(0.025)	0.89	(0.035)
6.4	(1/4)	0.622	(0.0245)	0.673	(0.0265)	0.64	(0.025)	0.89	(0.0350)
7.9	(5/16)	0.622	(0.0245)	0.724	(0.0285)	0.64	(0.025)	0.89	(0.0350)
9.5	(3/8)	0.622	(0.0245)	0.724	(0.0285)	0.64	(0.025)	0.89	(0.0350)
12.7	(1/2)	0.622	(0.0245)	0.724	(0.0285)	0.64	(0.025)	0.89	(0.0350)
15.9	(5/8)	0.800	(0.0315)	0.800	(0.0315)	0.81	(0.032)	1.24	(0.0488)
19.1	(3/4)	0.800	(0.0315)	0.978	(0.0385)	0.81	(0.032)	1.24	(0.0488)
22.2	(7/8)	1.041	(0.0410)	1.041	(0.0410)	1.17	(0.046)	1.65	(0.0650)
25.4	(1)	1.168	(0.0460)	1.168	(0.0460)	–	–	1.83	(0.0720)

<sup>a</sup>Nominal wall thickness of tubing will have to be greater than the thickness indicated to maintain the minimum wall thickness.  
<sup>b</sup>Within the product.

7.2.2 Tubing shall be constructed of corrosion resistant material, such as copper, or shall be plated, dipped, coated, or otherwise treated to resist external corrosion. Aluminum may be used if the material is not subject to galvanic corrosion. Copper or brass tubing shall not be used for ammonia (R717).

7.2.3 Tubing forming part of components, such as evaporators or condensers, where protection is afforded by inherent construction, shall be judged by the strength test requirements (Clause 8.24) of this Standard.

7.2.4 Special alloys or constructions used in refrigerant-containing components, including tubing with a wall thickness less than indicated in Clause 7.2.1 may be acceptable. Among the factors taken into consideration when judging their acceptability are (1) resistance to mechanical abuse, (2) strength against internal pressure, (3) resistance to corrosion, (4) protection against refrigerant contamination, and (5) compliance with requirements of safety codes, such as the Safety Code for Mechanical Refrigeration, ANSI/ASHRAE 15-1989 and the Mechanical Refrigeration Code, CSA B52-92, as compared to tubing of the minimum wall thicknesses indicated in Table 7.1.

7.2.5 Tubing connections shall be made by means of flare-type fittings with steel or forged brass nuts, by soldering or brazing, or by equivalent means. Flare-type fittings shall comply with the Standard for Refrigeration Tube Fittings, ANSI/SAE J513-1990. Joints in tubing intended to handle ammonia (R717) shall be brazed or welded.

7.2.6 A process tube (stub) shall be provided and located to facilitate removal of the refrigerant during servicing. The length of tubing provided as the process tube shall have a wall thickness not less than indicated in Table 7.1.

### 7.3 Refrigerant-containing parts

7.3.1 Parts subjected to refrigerant pressure shall withstand the pressure indicated in the strength tests – pressure containing components, Clause 8.24.

7.3.2 Parts subjected to refrigerant pressure shall be constructed of corrosion resistant material, such as copper or stainless steel, or shall be plated, dipped, coated, or otherwise treated to resist external corrosion. Copper or brass shall not be used in parts intended for use with ammonia (R717).

### 7.4 Pressure relief

7.4.1 A refrigerator shall be constructed so that pressure due to fire will be relieved. Pressure-relief devices, fusible plugs, or soldered or brazed tubing joints may be employed for this purpose.

7.4.2 A pressure-relief device is a pressure-actuated valve or rupture member, designed to relieve excessive pressures automatically.

7.4.3 Pressure-relief valves shall be set to start to function at a pressure not to exceed the design pressure of the parts of the system protected.

7.4.4 Rupture members shall have a nominal rated rupture pressure not exceeding the design pressure of the parts of the system protected.

7.4.5 Fusible plugs, pressure-actuated valves, and rupture members shall comply with the applicable requirements for Refrigerant-Containing Components and Accessories, UL 207, and Refrigerant-Containing Components for Use in Electrical Components, CSA Standard C22.2 No. 140.3.

7.4.6 No stop valve shall be located between any pressure relief device or fusible plug and the part or parts of the system protected thereby.

## 8 Performance

### 8.1 Instrumentation

#### 8.1.1 Temperature measurements

8.1.1.1 Temperatures are to be measured by thermocouples, except that the change-in-resistance method may be used to measure the temperature of motor windings or of coils. The thermocouples are to consist of 0.21 – 0.05 mm<sup>2</sup> (Nos. 24 – 30 AWG) wires. The thermocouples and related instruments are to be accurate and calibrated. The thermocouple wire is to comply with the requirements for "special thermocouples" as listed in the Table of Limits of Error of Thermocouples in the Standard for Temperature Measurement Thermocouples, ANSI MC96.1-1982.

8.1.1.2 A thermocouple junction and adjacent thermocouple lead wire are to be held in positive thermal contact with the surface of the material whose temperature is being measured. In most cases, thermal contact will result from securely taping or cementing the thermocouple in place, but where a metal surface is involved, brazing or soldering the thermocouple to the metal may be necessary.

8.1.1.3 If thermocouples are used in the determination of temperatures in connection with the heating of electrical equipment, it is a standard practice to employ thermocouples consisting of 0.05 mm<sup>2</sup> (No. 30 AWG) iron and constantan wires and a potentiometer type of indicating instrument. This equipment is to be used whenever referee temperature measurements by means of thermocouples are necessary.



8.1.1.4 If the temperature of a copper motor winding or coil is to be determined by the resistance method, the following formula shall be used:

$$T = \frac{R}{r} (234.5 + t) - 234.5$$

where:

T = The temperature to be determined in °C.

t = The known temperature in °C.

R = The resistance in ohms at the temperature to be determined.

r = The resistance in ohms at the known temperature.

8.1.1.5 When it is necessary to de-energize the winding before measuring R, the value of R at shutdown is to be determined by taking several resistance measurements at short intervals, beginning as quickly as possible after the instant of shutdown. A curve of the resistance values and the time is to be plotted and extrapolated to give the value of R at shutdown.

## 8.1.2 Pressure measurements

8.1.2.1 The equipment being tested shall have provision for monitoring high and low side pressures of the refrigeration system.

8.1.2.2 Where gauges are used to monitor high and low side pressures, they shall be attached in a manner that prevents leakage. Special fittings for direct connection to the system or minimum lengths of 3.2 mm (1/8 inch) outside diameter commercial capillary tubing may be employed for gauge connections. The volume of the pressure-measuring gauge and lines is to be held to a minimum. All joints in the gauge system are to be tested for leakage.

8.1.2.3 Opening of the gauge line valves shall not cause a significant change in the electrical input of the system that would prevent the refrigerator from operating in its intended manner. High-side gauges and lines may be heated above the saturation temperature corresponding to the expected pressure or may be precharged with a liquid refrigerant of the same type as used in the system to minimize the effect of opening the gauge line valves.

## 8.2 Test voltage and frequency

8.2.1 Unless otherwise stated, refrigerators shall be tested at the voltages specified in Table 8.1, maintained at the unit supply connections. Units intended for connection to alternating-current circuits (ac) shall be tested at 60 Hz frequency.

*Exception: Units rated at other than 60 Hz frequencies, and other than the voltages indicated in the table, are to be tested at their rated voltages and frequencies.*

**Table 8.1 – Test voltages**

Nameplate Voltage Rating	Test Voltage <sup>a</sup>
110 to 120 ac	120
200 to 208 ac	208
220 to 240 ac	240
DC appliances	Rated

<sup>a</sup> These voltages are nominal for the condenser fan motor failure test, Clause 8.11.

### 8.3 Leakage current test – cord-connected refrigerators

8.3.1 The leakage current of a cord-connected refrigerator shall be no more than 0.75 mA when tested in accordance with Clauses 8.3.6 and 8.3.7.

8.3.2 Leakage current refers to all currents, including capacitively coupled currents, that may be conveyed between exposed conductive surfaces of a refrigerator and ground or other exposed conductive surfaces.

8.3.3 All exposed conductive surfaces are to be tested for leakage currents. The leakage currents from these surfaces are to be measured to the grounded supply conductor. Parts are considered to be exposed surfaces unless guarded by an enclosure providing protection in accordance with Clauses 4.4.1 and 4.4.3. These leakage current measurements do not apply to terminals of extra-low voltage (Class 2) circuits.

8.3.4 If a conductive surface other than metal is used for the enclosure or part of the enclosure, the leakage current is to be measured using metal foil with an area of 100 × 200 mm (3.9 by 7.9 inches) in contact with the surface. If the surface is less than 100 × 200 mm (3.9 by 7.9 inches), the metal foil is to be the same size as the surface. The metal foil shall not remain in place long enough to affect normal operation, drainage, and ventilation of the refrigerator.

8.3.5 The measurement circuit for leakage current shall be as shown in Figure 8.1. The measurement instrument is defined in Items (a) – (c) and, unless it is being used to measure leakage from one part of a refrigerator to another, the meter is to be connected between the accessible parts and the grounded supply conductor. The meter that is actually used for a measurement need only indicate the same numerical value for a particular measurement as would the defined instrument. The meter used need not have all of the following attributes of the defined instrument:

- a) the meter is to have an input impedance of 1500 ohms resistive shunted by a capacitance of 0.15 microfarad;
- b) the meter is to indicate 1.11 times the average of the full-wave rectified composite waveform of voltage across the resistor or current through the resistor; and
- c) over a frequency range of 0 – 100 kHz, the measurement circuitry is to have a frequency response (ratio of indicated to actual value of current) that is equal to the ratio of the impedance of a 1500 ohm resistor shunted by a 0.15 microfarad capacitor to 1500 ohms. At an indication of 0.75 mA, the measurement is to have an error of not more than 5 percent.

Figure 8.1 – Leakage current measurement circuits

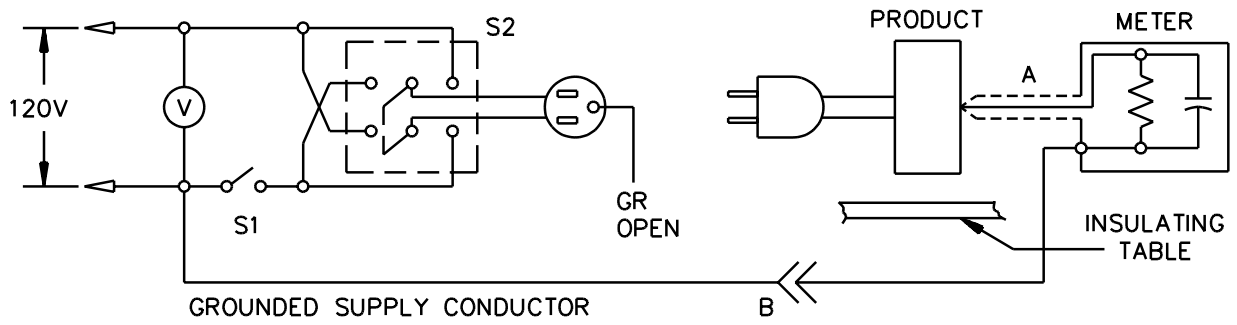

Appliance intended for connection to a 120 V power supply.

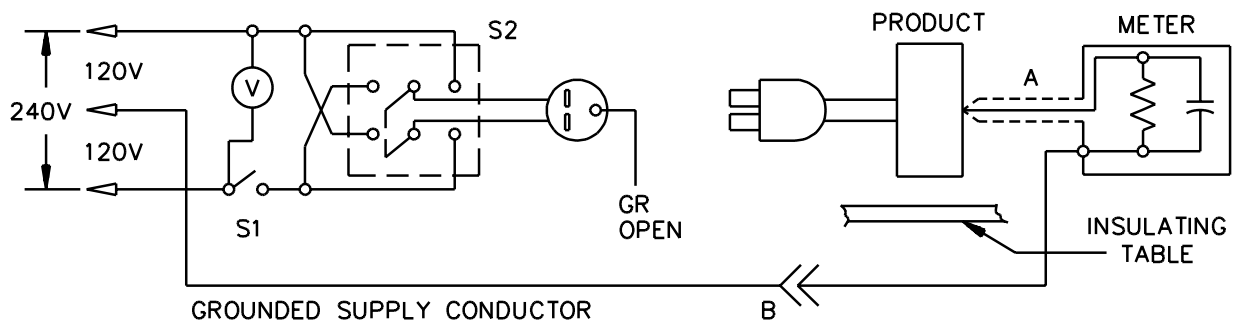

Appliance intended for connection to a 240 V 2-wire grounded power supply, as illustrated above.

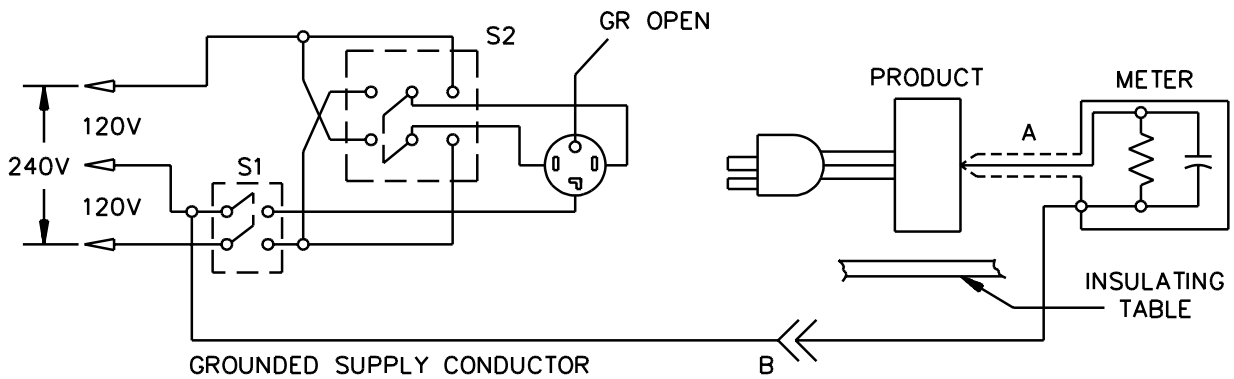

Appliance intended for connection to a 3-wire, grounded neutral power supply, as illustrated above.

A Probe with shielded lead.

B Separated and used as clip when measuring currents from one part of appliance to another.

8.3.6 A sample of the refrigerator is to be tested for leakage current starting with the as-received condition – as-received being without prior energization except as may occur as part of the production-line testing – but with its grounding conductor, if any, open at the grounding terminal or attachment plug. The supply voltage is to be adjusted to the voltage specified in Table 8.1. If the refrigerator is intended to be connected to a water supply, these connections are to be made with nonconductive tubing.

8.3.7 With reference to the measuring circuit in Figure 8.1, the leakage current test sequence shall be as described in Items (a) – (d) below:

- a) with switch S1 open, the unit is to be connected to the measuring circuit. The leakage current is to be measured using both positions of switch S2 and with manually-operated unit switching devices successively placed in each mode (unit thermostat, anticondensation heaters, door switches, and the like);
- b) with unit controls set for lowest storage compartment temperature, switch S1 is to be closed to energize the unit. Within 5 seconds, leakage current is to be measured using both positions of switch S2. Following this and using both positions of switch S2, manual switching devices are to be operated as quickly as possible through all modes, but not in the "refrigerator off" position, to determine the maximum leakage current condition;
- c) with switching devices set at the position that causes the highest leakage current, as determined in Item (b), the unit is to be operated continuously through all modes, including defrost and ice making/harvesting, until the measured leakage current stabilizes or decreases. Both positions of switch S2 are to be used; and
- d) following Item (c), switch S1 is to be opened to de-energize the unit. Measurement of leakage current is to continue, using both positions of switch S2, until values stabilize or begin to decrease.

If the compressor stalls during sequence (b) or (c) due to changing the position of switch S2, the sequence is to be conducted in its entirety in one position of switch S2 and then repeated in the second position of switch S2.

8.3.8 A refrigerator shall also comply with the requirements for leakage current in Clause 8.3.1 following exposure for 24 hours to air having a relative humidity of  $85\pm 5$  percent at a temperature of  $32.2\pm 2^{\circ}\text{C}$  ( $90\pm 4^{\circ}\text{F}$ ).

#### **8.4 Component washing test**

8.4.1 A lampholder, switch, or other electrical component shall be mounted so that leakage current resulting from cleaning in and around food storage compartments of a refrigerator is not greater than 0.5 mA.

8.4.2 The refrigerator is to be isolated from ground with the normal grounding means disconnected and is to be connected so that the component to be tested is in the ungrounded side of the supply. Control knobs, guards, panels, food storage components, and the like, that are located in the area to be cleaned and that are removable without the use of tools, are to be removed. Lamps are to be in place. The test is to be conducted at a temperature of approximately  $25^{\circ}\text{C}$  ( $77^{\circ}\text{F}$ ).

8.4.3 The refrigerator is to be energized as indicated in Table 8.1 but with the refrigeration system not operating. The measurement circuit for leakage current shall be as shown in Figure 8.2. The meter used for measurement of leakage current is to have the characteristics defined in Items (a) – (c) of Clause 8.3.5. The meter is to be connected between a metal backing on a cellulose sponge and the grounded conductor of the power supply.

Figure 8.2 – Component washing current measurement circuits

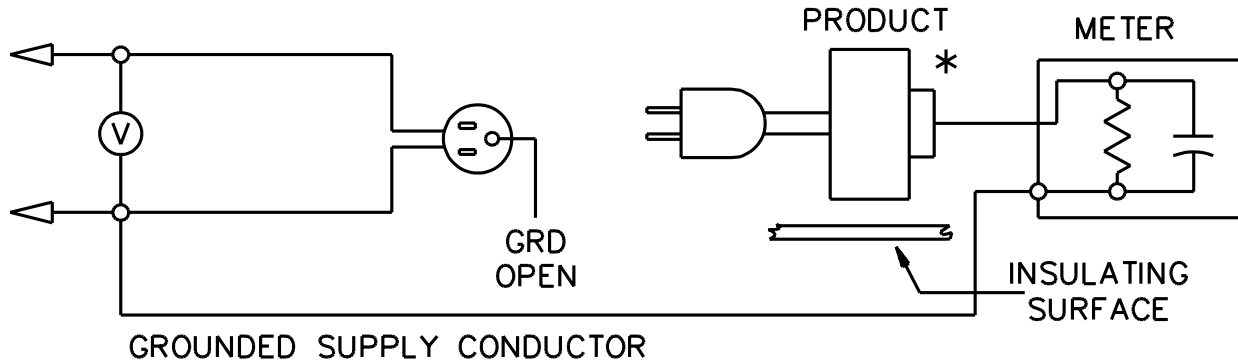

LC100H

\*Sponge with metal backing. See Clause 8.4.4.

8.4.4 The sponge is to be approximately 41.3 by 76.2 by 127.0 mm (1-5/8 by 3 by 5 inches), capable of retaining from 75 to 100 grams of solution, and is to have a metal backing on one of the 76.2 by 127.0 mm (3 by 5 inch) faces.

8.4.5 The sponge is to be saturated in a solution consisting of 10 mL (2 tbsp.) of sodium bicarbonate and 4.5 grams of chip soap, in 0.95 L (1 quart) of water at approximately 25°C (77°F). The saturated sponge is to be wiped six times with a pressure of 8.9 to 13.4 N (2 to 3 pounds) applied to the metal-backed side, over the exposed mounting surfaces, including any operating devices of the electrical components. The sponge shall be resaturated in the test cleaning solution after the third wipe.

8.4.6 The test is to be conducted with manually-operable switch contacts, integral to the refrigerator, in the open and closed positions. An equal number of wipes shall be applied at each position of the switch or control such that the total is six (three wipes at each position for 2-position switch; two wipes at each position for 3-position switch).

## 8.5 Input test

8.5.1 The measured ampere input to a refrigerator shall not exceed the total rating marked on the nameplate by more than 10 percent when tested as described in the temperature and pressure test, Clause 8.6, and the defrost test, Clause 8.9.

*Exception: The input to an absorption refrigerator shall not exceed its marked rating by more than 5 percent when tested at rated voltage.*

8.5.2 For the purpose of Clause 8.5.1, the measured ampere input is to be the value obtained 30 minutes after continuous operation under cooling conditions and is to be the maximum value measured during defrost operation. The power input for all accessories shall be included when establishing the minimum marked rating of the refrigerator.

## 8.6 Temperature and pressure test

8.6.1 Temperatures of electrical components, wiring, enclosure surfaces, and the like shall not exceed those specified in Table 8.2.

**Table 8.2 – Maximum acceptable temperatures**

Device or material		°C	°F
A.	MOTORS		
	1. Class A insulation systems on coil windings of alternating-current motors having a frame diameter of 178 mm (7 inches) or less (not including hermetic motor-compressors) <sup>a</sup>		
	a. In open motors –		
	Thermocouple or resistance method	115	239
	b. In totally enclosed motors –		
	Thermocouple or resistance method	120	248
	2. Class A insulation systems on coil windings of alternating-current motors having a frame diameter of more than 178 mm (7 inches) (not including hermetic motor-compressors) <sup>b</sup>		
	a. In open motors –		
	Thermocouple method	105	221
	Resistance method	115	239
	b. In totally enclosed motors –		
	Thermocouple method	110	230
	Resistance method	120	248
	3. Class B insulation systems on coil windings of alternating-current motors having a frame diameter of 178 mm (7 inches) or less (not including hermetic motor-compressors)		
	a. In open motors –		
	Thermocouple or resistance method	135	275
	b. In totally enclosed motors –		
	Thermocouple or resistance method	140	284

Table 8.2 – Maximum acceptable temperatures Continued

Device or material	°C	°F
4. Class B insulation system on coil windings of alternating-current motors having a frame diameter of more than 178 mm (7 inches) (not including hermetic motor-compressors)		
a. In open motors –		
Thermocouple method	125 135	257 275
Resistance method		
b. In totally enclosed motors –		
Thermocouple method	130	266
Resistance method	140	284
B. COMPONENTS		
1. Capacitors		
Electrolytic type <sup>c</sup>	80	176
Other types <sup>d</sup>	105	221
2. Field wiring	75	187
3. Fuses		
a. Class CC, J, L and T		
Tube	140	284
Ferrule or blade	125	257
b. Other classes <sup>e</sup>	105	221
4. Hermetic motor-compressor enclosure	150	302
5. Relay, solenoid, and other coils (except motor coil windings) with: <sup>b</sup>		
a. Class 105 insulated winding –		
Thermocouple method	105	221
Resistance method	125	257
b. Class 130 insulation –		
Thermocouple method	125	257
Resistance method	145	293
6. Solid contacts	105	221
7. Transformer enclosures with –		
a. Class 2 transformers	100	212
b. Power transformers	105	221



**Table 8.2 – Maximum acceptable temperatures Continued**

Device or material		°C	°F
	8. Wood or other flammable material	90	206
C.	INSULATED CONDUCTORS <sup>f</sup>		
	1. Flexible cords and wires with rubber, thermoplastic, or neoprene insulation	60	140
D.	SURFACES		
	1. Surfaces of refrigerators at points of zero clearance to test enclosure	105	221
	2. Surfaces of refrigerator contacted by the persons in operating it (control knobs, pushbuttons, levers and the like)		
	Metal	75	167
	Nonmetallic	100	212
	3. Surfaces of refrigerator subjected to casual contact by persons (enclosure, grille, and the like)		
	Metal	85	185
	Nonmetallic	105	221
	4. Surfaces of test enclosure including the surface below refrigerator	90	206
E.	ELECTRICAL INSULATION – GENERAL <sup>f</sup>		
	1. Fiber used as electrical insulation or cord bushings	105	221
	2. Phenolic composition used as electrical insulation or as parts where failure will result in a hazardous condition	165	329
	3. Thermoplastic material	–	–
<p><sup>a</sup> Thermocouple applied directly to the integral insulation of the coil conductor.</p> <p><sup>b</sup> Thermocouple applied as in (a) or applied to conventional coil wrap.</p> <p><sup>c</sup> For an electrolytic capacitor which is physically integral with or attached to a motor, the temperature on insulating material integral with the capacitor enclosure may be not more than 90°C (194°F).</p> <p><sup>d</sup> A capacitor may operate at a temperature higher than 90°C (194°F), but not higher than its marked temperature rating.</p> <p><sup>e</sup> Includes both casing and ferrule or blade.</p> <p><sup>f</sup> The limitations on phenolic composition and on rubber and thermoplastic insulation do not apply to compounds that have been investigated and found to be acceptable for higher temperatures than those specified in this Table.</p>			

8.6.2 The maximum pressures developed in the refrigeration system, including equalization pressure after compressor shutdown, shall be used in applying strength test requirements, Clause 8.24. See Clause 8.6.6.

8.6.3 A motor-compressor shall be capable of operating continuously under the conditions of this test with any protective device in the circuit.

*Exception: An automatic reset protective device may cycle during the first eight hours of the test. A manual reset protective device shall not trip during the test.*

8.6.4 The refrigerator is to be fitted with pressure gauges on the high- and low-pressure sides of the refrigeration system. Thermocouples are to be secured to components, such as the motor-compressor enclosure, fan motor windings, conductor insulation including heater wire intended to prevent moisture formation on external surfaces, enclosure surfaces, and the like as indicated in Table 8.2. The temperature of motor windings or of coils may be measured by the change-in-resistance method, but the primary method of temperature measurement is to be the thermocouple method. The refrigerated compartment temperature controller is to be set for maximum cooling or is to be shunted out of the circuit to permit continuous operation of the refrigeration system.

8.6.5 The refrigerator is to be installed in accordance with the manufacturer's instructions. See Clauses 11.2.1 and 11.2.2. The test enclosure for a recessed or built-in refrigerator or, when applicable, a refrigerated kitchen unit is to consist of a bottom surface, back, two sides, and top constructed of 9.5 mm (3/8 inch) thick plywood with the inside surfaces painted flat black and with all joints taped or otherwise sealed. The enclosure is to be in close contact with the refrigerator unless the unit is marked with specific clearances in accordance with Clause 11.1.10 and as indicated in the installation instructions. The test enclosure for a freestanding refrigerator is to consist of a bottom surface and back constructed of 9.5 mm (3/8 inch) thick plywood painted flat black. The appliance is to be placed on the bottom surface and against the back surface in as close proximity as permitted by the design.

8.6.6 The refrigerator is to be placed in a room maintained at 40°C (104°F) with doors or lids open until the unit reaches room temperature. Doors and lids are then to be closed and the unit started and operated until current, temperatures, and pressures have stabilized. Electrical loads that may operate concurrently with the condensing unit are to be energized during the test. The test voltage is to be as specified in Table 8.1. With reference to Clause 8.6.2, pressures are to be monitored continuously. After stabilization, the unit is to be de-energized and pressures recorded to obtain maximum equalization values.

*Exception: The electrical input to absorption type refrigerators during the temperature and pressure test shall be as follows:*

*If the voltage rating is in the range of 100 to 120 V inclusive, or 200 to 240 V inclusive, the refrigerator shall be connected to a supply circuit of voltage sufficient to cause a power input equal to:*

$$W_m[120/V_m]^2 \text{ or } W_m[240/V_m]^2$$

where

$W_m$  = the rated power input; and

$V_m$  = the rated voltage.

If the rated voltage is less than 100 V or more than 120 V or less than 200 V or more than 240 V, the refrigerator shall be connected to a supply circuit of voltage sufficient to cause a power input equal to the rated input.

8.6.7 The ambient air temperature is to be recorded at points located 915 mm (3 feet) above the floor line and 254 mm (10 inches) from the center of the two sides of the cabinet. The temperature at each point is to be maintained within  $\pm 1.1^\circ\text{C}$  ( $\pm 2^\circ\text{F}$ ) of the value specified in Clause 8.6.6 and is to be recorded at not greater than 30-minute intervals.

8.6.8 The refrigerator shall comply with the dielectric voltage-withstand test, Clause 8.8, following this test.

### **8.7 Starting test**

8.7.1 A cord-connected refrigerator shall start, operate, defrost, and restart after defrost without opening the branch circuit for which it is designed.

8.7.2 To determine compliance with the requirements of Clause 8.7.1, the refrigerator shall be connected and operated in series with a line fuse as indicated in Clause 8.7.1, under the load conditions specified in Clauses 8.6 and 8.9. If the fuse blows, the test shall be repeated using a time delay fuse.

8.7.3 If a time delay fuse is required for the test specified in Clause 8.7.2, the refrigerator shall be marked as specified in Clause 11.1.4.

### **8.8 Dielectric voltage-withstand test**

8.8.1 A refrigerator shall withstand, without breakdown, a test potential applied for 1 minute between line-voltage live parts and dead metal parts and between live parts of line-voltage and extra-low voltage circuits. The test potential shall be 1000 V plus twice rated voltage and shall be at any frequency between 40 and 70 hertz.

*Exception No. 1: The test potential for units rated at not more than 1/2 horsepower (373 watts output) shall be 1000 V.*

*Exception No. 2: If the steady-state voltage developed in a motor circuit through the use of capacitor exceeds 500 V, as measured during the temperature and pressure test, Clause 8.6, the test potential for the parts affected shall be 1000 V plus twice the developed capacitor voltage.*

8.8.2 A refrigerator employing an extra-low voltage circuit shall withstand, without breakdown, a test potential of 500 V applied for 1 minute between extra-low voltage live parts and dead metal parts. The test potential shall be at any frequency between 40 and 70 hertz. If protective devices such as specified in Clause 6.2.3 are employed in the extra-low voltage circuit, the test shall also be conducted between live parts of opposite polarity.

8.8.3 With reference to Clause 8.8.2, the test between extra-low voltage parts of opposite polarity is to be conducted on magnet coil windings of the transformer after breaking the inner coil lead where it enters the layer. The opposite polarity test may be waived on the complete assembly provided that the components have been separately subjected to this test.

8.8.4 A 500 VA or larger transformer, the output voltage of which is essentially sinusoidal and can be varied, is to be used to determine compliance with Clauses 8.8.1 and 8.8.2. The applied potential is to be increased gradually from zero until the required test value is reached and is to be held at the value for 1 minute.

*Exception: The requirement of a 500 VA or larger transformer can be waived if the high potential testing equipment is such that it maintains the specified high potential voltage at the product for the duration of the test.*

8.8.5 If the charging current through a capacitor or capacitor-type filter connected across the line, or from line to earth ground, is large enough to make it impossible to maintain the required alternating-current test potential, the capacitors and capacitor-type filters may be tested as described in 8.8.6.

8.8.6 The capacitors and capacitor-type filters mentioned in 8.8.5 are to be subjected to a direct-current test potential of 1414 volts for equipment rated 250 volts or less or 1414 volts plus 2.828 times the rated circuit voltage for equipment rated at more than 250 volts. The direct-current test potential is to be maintained for 1 minute without breakdown.

8.8.7 Components providing a direct-current path in parallel with the insulation to be tested, such as discharge resistors for filter capacitors and voltage limiting devices (transient voltage suppressors), may be disconnected during the test.

## **8.9 Defrost test**

8.9.1 When operating in the defrost mode, temperature rises of electrical components, wiring, enclosure surfaces, and the like, of a refrigerator shall not exceed the values specified in Table 8.2. The test voltage is to be as specified in Table 8.1.

8.9.2 A hot-gas or reverse-cycle defrost system shall not rupture or develop leaks during the test. The maximum high- and low-side pressures are to be recorded as reference values for requirements of the strength tests – pressure containing components, Clause 8.24.

8.9.3 The defrost test sequence is to be as specified in Items (a) – (e):

a) the appliance is to be installed in a room maintained at 32.2°C (90°F) dry bulb, 28.3°C (83°F) wet bulb. Automatic controls that initiate the defrost cycle and food storage compartment temperature controls are to be shunted out of the circuit;

b) the refrigeration system is to be operated continuously for 8 hours. During this period, the refrigerator door(s) is to be opened at least 45 degrees but not more than 90 degrees and closed at uniform intervals. The door opening and closing cycle is to be between 15 and 45 seconds in duration with a sufficient number of cycles to result in 36 minutes total open time during the 8 hour period;

*Exception: If the frequency of defrost cycles exceeds 3 in a 24 hour period, the refrigeration system may be operated for the maximum period permitted by the defrost control (timer) with a proportionate reduction in the total open time during this period.*

- c) following Item (b), the refrigerator door(s) is to be closed and controls placed back in the circuit. The refrigerator shall be operated by setting the control device to the point of completion of a defrost cycle. The test shall commence with the initiation of the next defrost cycle. In addition to electrical input, temperatures and pressures are to be recorded as specified in Clauses 8.9.1 and 8.9.2;
- d) following Item (c), thermocouples are to be disconnected from the measuring instruments, and the pressure gauges are to be isolated from the ground. The appliance is to be connected to the leakage current measurement circuit shown in Figure 8.1. Leakage current is to be measured in accordance with Clause 8.3.7(a) and (b). The appliance is then energized and, after approximately 2 minutes of compressor operation, is to be manually returned to defrost operation. Leakage current then is to be measured for approximately two additional minutes. After defrost operation, the refrigerator shall have a leakage current of not more than 0.75 mA; and
- e) upon completion of the defrost cycle, the appliance shall be subjected to the dielectric voltage-withstand test, Clause 8.8. The appliance shall then be examined to see if defrost water has come into contact with bare live parts.

No Text on This Page

## 8.10 Defrost heater burnout test

8.10.1 Operation of a defrost heater shall not result in a risk of fire or electric shock.

8.10.2 A risk of fire is considered to exist if there is emission of flame or molten metal from the refrigerator or glowing or flaming of flammable material.

8.10.3 A risk of electric shock is considered to exist if the insulation resistance of the refrigerator is less than 50,000 ohms.

8.10.4 Opening of a sheath-type or glass-enclosed heater element is acceptable if the risk of fire and electric shock does not exist. If the heater element opens, three samples are to be tested to determine that the heater is constructed to function in this manner.

8.10.5 The ambient air temperature is to be approximately 25°C (77°F). The defrost heater is to be energized at the voltage specified in Table 8.1.

8.10.6 If an automatic-reset temperature-limiting control is employed, the test is to terminate when the temperatures of components and materials, such as conductor insulation, electrical insulation, thermal insulation, and flammable materials near the heater element have stabilized. If a manual-reset temperature-limiting control is employed, the test is to terminate when the device opens the heater circuit. All other controls are to be shunted out of the circuit.

*Exception: This test need not be conducted if the temperature-limiting control is calibrated to open the circuit at a temperature of 25°C (77°F) or less.*

## 8.11 Condenser fan motor failure test

8.11.1 A refrigerator shall not leak refrigerant nor develop pressures or temperatures in excess of those indicated in Items (a) and (b) below, if the condenser fan motor locks or fails to start:

- a) the maximum high- and low-side pressures shall not exceed one-third of the ultimate strength of high- and low-side parts, respectively, as determined by strength tests – pressure containing components, Clause 8.24; and
- b) the temperature of the compressor motor enclosure, of the fan motor winding (open type) or of the fan motor enclosure (enclosed type) shall not exceed 150°C (302°F). Compressors and condenser fan motors equipped with a thermal protective device(s) as specified in motors and motor overload protection, Clause 5.7, are considered to comply with this requirement.

8.11.2 The unit, fitted with pressure gauges on the high- and low-pressure sides of the refrigeration system and provided with thermocouples on the compressor motor enclosure and condenser fan motor winding (open type) or condenser fan motor enclosure (enclosed type), is to be operated with the condenser fan motor locked. Where two or more condenser fan motors are employed, the test is to be conducted with one motor locked. Operation is to continue until maximum stabilized temperatures and pressures are reached or until representative maximum temperatures and pressures are attained under cycling load. The low-side pressure is to be recorded while the compressor is operating and after shutdown. The compressor motor overload device and the fan motor overload device may operate during this test. The ambient air temperature is to be approximately 25°C (77°F). The test voltage is to be maintained as indicated in Table 8.1.

8.11.3 A recessed or built-in refrigerator is to be enclosed as described in Clause 8.6.5 for this test.

### 8.12 Overflow test

8.12.1 Overflow of liquid in a refrigerator shall not result in wetting of uninsulated live parts or film-coated wire in line-voltage circuits. See Clauses 4.5.5 – 4.5.7.

8.12.2 To determine compliance with Clauses 4.5.5 – 4.5.7, refrigerators shall be positioned as intended in use and investigated for the following conditions:

- a) overflow of a pan, trough, or the like, at a rate of 30 mL/s for a maximum period of 30 s;
- b) overflow of a blocked drain at a rate of 30 mL/s for a maximum period of 30 s;
- c) overflow caused by an inlet valve being blocked open; and
- d) wetting caused by leakage from a water line connection after 5 minutes. For this test, the water line connections are to be fully and/or partially disconnected such that the leakage is directed toward electrical components.

For Items (c) and (d), the water pressure shall be maintained at 275 – 415 kPa gauge (40 – 60 psig) for the duration of the test.

8.12.3 Compliance with Clause 8.12.1 shall be determined by visual examination, except that where visual examination is not practical, insulation resistance and dielectric voltage-withstand tests are to be conducted immediately after overflow has occurred. The refrigerator shall (1) have an insulation resistance of not less than 50,000 ohms measured between current-carrying parts and noncurrent-carrying parts and (2) comply with requirements of the dielectric voltage-withstand test, Clause 8.8.

### 8.13 Spill test

8.13.1 External spillage of liquid on a refrigerator shall not result in wetting of uninsulated live parts or film-coated wire in line-voltage circuits. See Clause 4.5.9.

8.13.2 The refrigerator is to be tilted at an angle of up to 2° to the position of normal use, in the direction which is likely to be most unfavorable for the test. 500 ml (17 oz) of water containing 1 percent NaCl are to be poured on the top surface of the unit at a rate of 30 ml/s (1 oz/s).

8.13.3 Compliance with Clause 8.13.1 shall be determined within 30 minutes after the water is poured on the top of the refrigerator by visual examination, dielectric voltage-withstand, or insulation resistance, except that windings of motors that are exposed to spillage shall (1) have an insulation resistance of not less than 50,000 ohms and (2) comply with the dielectric voltage-withstand test, Clause 8.8.

### 8.14 Stability test

8.14.1 A refrigerator shall be stable when tested in accordance with Clause 8.14.2. A refrigerator is considered to comply with the requirement if (1) both the width and depth dimensions of the supporting base are greater than the height of the unit or (2) it is intended to be permanently attached to a wall, floor, or the like.



8.14.2 The refrigerator is to be supported by the legs, leveling screws, rollers, or the like, provided in the base of the unit. A built-in refrigerator is to be installed in accordance with the manufacturer's instructions. Plumbing or conduit connections are not to be relied on for the purpose of the test. The refrigerator shall not overturn under the conditions specified in Items (a) and (b):

a) an empty refrigerator, with doors, covers, and panels closed, is to be placed on a plane surface inclined at an angle of 10 degrees from the horizontal. Accessories that are intended for use with the refrigerator are to be installed. Swivel-type casters, if any, are to be oriented so that the tendency to overturn is maximum. The refrigerator is to be restrained if necessary to prevent it from sliding or rolling.

Or an empty refrigerator, with accessories installed, that has a mass of 22.7 kg (50 pounds) or more is to be placed on a horizontal surface. If leveling screws are provided, they are to be adjusted equally to raise the refrigerator to the maximum adjustable level, but not more than 25.4 mm (1 inch) above floor level. The refrigerator is to be restrained, if necessary, to prevent it from sliding or rolling. The refrigerator is to be loaded with one-third of the total food-storage load determined in accordance with Clause 8.25.3. This load is to be distributed over each food-supporting component and located approximately at the center of the component. If swivel-type casters are provided, they are to be oriented so that the tendency to overturn is maximum. All doors are to be closed. A force equal to one-fifth the weight of the empty refrigerator, but not more than 222.5 N (50 pounds-force) is to be applied horizontally at the vertical centerline of any side of the refrigerator at the highest point, not to exceed 1.5 m (5 feet) above floor level; and

b) an empty refrigerator, with accessories installed, that has a mass of 22.7 kg (50 pounds) or more is to be placed on a horizontal surface. If leveling screws are provided, they are to be adjusted equally to raise the refrigerator to the maximum adjustable level, but not more than 25.4 mm (1 inch) above floor level. The refrigerator is to be restrained, if necessary, to prevent it from sliding or rolling. The refrigerator is to be loaded with one-third of the total food-storage load determined in accordance with Clause 8.25.3. This load is to be distributed over each food-supporting component and located approximately at the center of the component. If swivel-type casters are provided, they are to be oriented so that the tendency to overturn is maximum. A force equal to one-fifth the weight of the empty refrigerator, but not more than 222.5 N (50 pounds-force), is to be applied vertically downward at the edge of the widest exterior door farthest from the hinges, with the door opened at an angle of 90 degrees to the cabinet. All other doors are to be closed. Shelves, drawers, and other food storage components are to be in their normal storage position. This test is not to be conducted on chest-type units.

### 8.15 Static load test – cabinets

8.15.1 A refrigerator shall withstand the test described in Clause 8.15.3 without (1) damage to the refrigeration system as evidenced by release of refrigerant, (2) reduction of electrical spacings below those specified in line-voltage circuits, Clause 6.1, and extra-low voltage (Class 2) circuits, Clause 6.2, (3) exposing moving or live parts as judged by the requirements of general (construction), Clause 4.5, and (4) reducing the insulating properties of internal wiring as judged by the dielectric voltage-withstand test, Clause 8.8.

*Exception: This test can be waived if by visual examination it can be determined that the refrigerator would comply with the requirements of Clause 8.15.1.*

8.15.2 In addition to the requirement of Clause 8.15.1, a wall-hung refrigerator shall withstand the test described in Clause 8.15.3 without (1) collapse of the mounting means, and (2) severance of its securement to the mounting means when fastened to a wall.

8.15.3 A load of 667 N (150 pounds-force) is to be simultaneously applied for a period of 5 minutes to each of two flat metal plates. The plates are to be 101.6 mm (4 inches) wide, 254 mm (10 inches) long, and approximately 6.4 mm (1/4 inch) thick. The plates are to be positioned with the major axes parallel to each other and to the sides of the cabinet as shown in Figure 8.3.

*Exception: If the width of the refrigerator is less than 508 mm (20 inches), the 203.2 mm (8 inch) dimension shown in Figure 8.3 is to be disregarded and the plates are to be located so their outside edges are flush with the sides of the cabinet.*

**Figure 8.3 — Static load test arrangement**

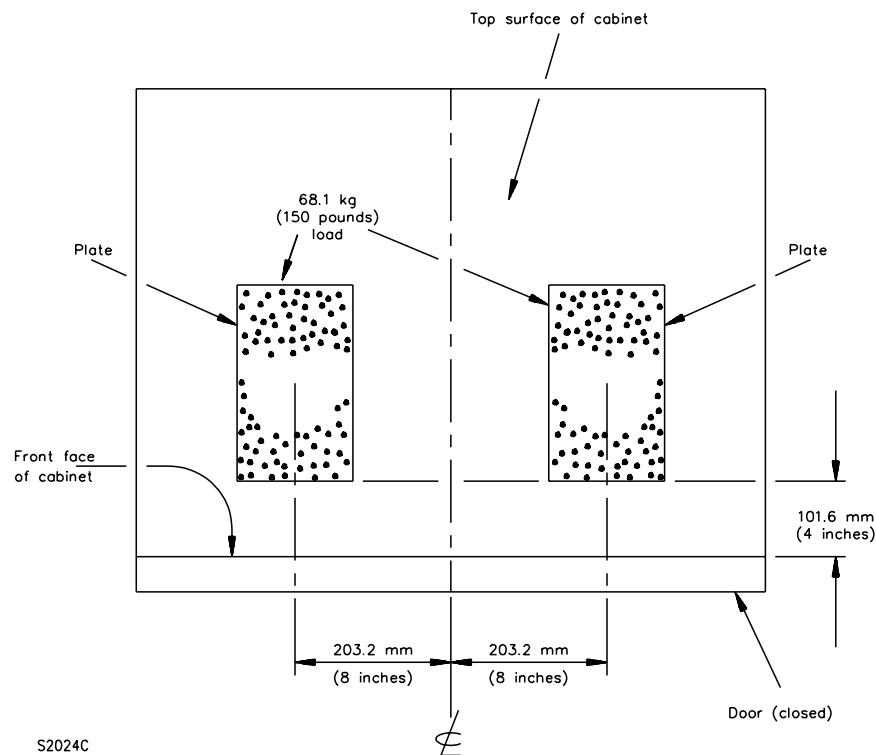

## 8.16 Strain relief test

8.16.1 The strain relief means provided on a power supply cord, including that for an externally-mounted accessory, and exposed crossover wiring to a door shall withstand a direct pull of 156 N (35 pounds-force) applied to the cord or wiring.

8.16.2 The strain relief means provided on leads intended for connection of field-installed supply conductors and power supply conductors for internally-mounted accessories shall withstand a direct pull of 89 N (20 pounds-force) applied to the conductors.

No Text on This Page

8.16.3 To determine the acceptability of the strain relief, a 15.9 kg (35 pound) or 9.1 kg (20 pound) weight, is to be suspended on the cord or wiring and supported by the refrigerator so that the strain relief will be stressed from any angle that the design of the refrigerator permits. The load is to be applied for 1 minute. The strain relief is not acceptable if there is such movement of the cord or wiring as to indicate that stress would be transmitted to internal connections and wiring.

### **8.17 Overvoltage and undervoltage tests**

8.17.1 An electromagnet, such as employed on a relay or solenoid, in an extra-low voltage circuit, shall withstand a voltage 10 percent higher than rated voltage without damage and shall operate at that voltage and also at 15 percent less than rated voltage. If the component is supplied by an extra-low voltage transformer provided as part of the unit, the voltage adjustments are to be based on and made in the primary of the transformer.

8.17.2 The relay or solenoid is to be connected to a supply source maintained at the overvoltage condition until the coil of the relay or solenoid reaches constant temperature. The potential is then to be reduced to rated voltage and the relay or solenoid shall operate at this voltage. The potential is to be maintained at this voltage until the coil reaches constant temperature. The potential then is to be reduced to the undervoltage condition, and the relay or solenoid shall operate at this voltage. A relay or solenoid that will not be subject to continuous operation is to be energized at the overvoltage condition and at rated voltage for the maximum time permitted by its duty cycle or until constant temperature is reached, whichever occurs first.

### **8.18 Limited short circuit test**

#### **8.18.1 General**

8.18.1.1 The components specified in items (a) and (b) shall withstand short-circuiting when protected by a fuse of the size required by the refrigerator:

- a) motor overload protective devices that are connected in the motor circuit; and
- b) bonding conductors and connections as required by Clause 4.9.5.13.

8.18.1.2 For a cord-connected unit, the protection specified in Clause 8.18.1.1 is to be provided by a fuse having a rating not less than the rating of the unit's attachment plug. The minimum fuse size for cord-connected refrigerators is 20 A for units rated 125 V or less and 15 A for units rated 126 – 250 V.

8.18.1.3 For a permanently-connected unit, the protection specified in Clause 8.18.1.1 is to be provided by a fuse rated as shown on the unit nameplate but not less than 15 A.

8.18.1.4 The component is to be connected in a test circuit having a capacity based on the rated-load current and voltage rating of the refrigerator. See Table 8.3. When the rated-load current is between two values in the table, the larger value is to be used in determining the circuit capacity. If the refrigerator nameplate shows individual loads, the rated-load current is to be the total of all individual loads that may occur simultaneously. If more than one simultaneous load condition is possible, the condition resulting in the maximum total current is to be used as a basis for determining the capacity of the test circuit. The voltage for the test circuit is to be an alternating current supply, and the circuit capacity is to be measured without the component in the circuit. The power factor of the test circuit is to be 0.9 – 1.0 unless a lower power factor is acceptable to those concerned.

**Table 8.3 – Short-circuit test-currents**

Refrigerator rated-Load amperes			Circuit capacity, amperes
110 – 120 V	200 – 208 V	220 – 240 V	
9.8 or less	5.4 or less	4.9 or less	200
9.9 – 16.0	5.5 – 8.8	5.0 – 8.0	1000
–	8.9 – 12.0	8.1 – 12.0	2000

8.18.1.5 Three samples of each component or conductor under test are to be subjected to each test condition and a new protective device is to be used for each test. Consideration is to be given to both short-circuit and ground-fault conditions.

#### 8.18.2 Motor overload protective devices

8.18.2.1 There shall be no ignition of cheesecloth surrounding the enclosure of a motor protective device when samples are subjected to the test.

#### 8.18.3 Bonding conductors and connections

8.18.3.1 Bonding conductors and connections shall not open when samples are subjected to this test.

### 8.19 Current overload test – bonding conductors and connections

8.19.1 If required by Clause 4.9.5.13, bonding conductors and connections shall carry a current of 40 A for 120 V units, or 30 A for 240 or 208 V units, for 2 minutes without opening.

### 8.20 Defrost heater control tests

#### 8.20.1 Endurance test

8.20.1.1 A control for an electric defrost heater shall withstand, without electrical or mechanical malfunction, an endurance test under the load that it controls for the number of cycles indicated in Clause 8.20.1.2.

8.20.1.2 The number of cycles for the test is to be as specified in Items (a) – (c):

- a) an automatic-reset or a time-on, time-off defrost cycle control that operates during each defrost cycle is to withstand 30,000 cycles of operation under load. If this control also serves to limit temperatures, see Item (b);
- b) an automatic-reset temperature-limiting control is to withstand 100,000 cycles of operation under load if short-circuiting of the control during the defrost heater burnout test results in a risk of fire or electric shock as defined in Clauses 8.10.2 and 8.10.3; and
- c) a manual-reset temperature-limiting control is to withstand 1000 cycles of operation under load plus an additional 5000 cycles without load. The test may be waived if short-circuiting of the control during the defrost heater burnout test does not result in a risk of fire or electric shock as defined in Clauses 8.10.2 and 8.10.3.

8.20.1.3 The test is to be conducted with the device connected either to the heater element load or to an equivalent noninductive load. The frame of the device is to be connected through a 3 A fuse to ground or to the grounded conductor of the supply circuit and the fuse shall not open.

#### 8.20.2 Calibration test

8.20.2.1 Temperature responsive defrost cycle controls and temperature-limiting controls shall comply with the Standard for Temperature-Indicating and -Regulating Equipment, UL 873, and Temperature-Indicating and -Regulating Equipment, CSA Standard C22.2 No. 24, pertaining to the calibration of temperature-limiting controls.

### 8.21 Insulation resistance test

#### 8.21.1 Defrost heaters

8.21.1.1 The insulation resistance of encapsulated heaters and sheath-type elements that (1) employ moisture-absorbent insulation and (2) are exposed to moisture in a refrigerator shall be not less than 50,000 ohms when tested in accordance with Clauses 8.21.1.2 and 8.21.1.3. The heater shall comply with the dielectric voltage-withstand test, Clause 8.8, following exposure.

8.21.1.2 If an encapsulated heater or heater terminal seal is immersed in water as it is used in the refrigerator, the test is to be conducted by cycling the heater for 30 days, submerged in water. The water is to be maintained at a temperature of 94 – 100°C (194 – 212°F). The heater is to be energized at its rated voltage and cycled at a rate of approximately 1.5 minutes on and 13.5 minutes off.

8.21.1.3 If an encapsulated heater or heater terminal seal is exposed to moisture but not subject to more than casual contact with water in the refrigerator, the test is to be conducted by cycling the heater assembly or terminal seal in an atmosphere of not less than 98 percent relative humidity at any convenient temperature above 0°C (32°F). The heater is to be energized at its rated voltage and operated for 1000 cycles at a rate of 1.5 minutes on and 13.5 minutes off.

#### 8.21.2 Thermal and acoustical insulating material

8.21.2.1 A refrigerator employing insulating material subject to the deteriorating conditions of moisture shall have an insulation resistance of not less than 50,000 ohms between live parts and interconnected dead metal parts after exposure for 24 hours to moist air having a relative humidity of 85±5 percent at a temperature of 32±2°C (90±4°F).

### 8.22 Accelerated aging test – electric heaters

8.22.1 Rubber, neoprene, or thermoplastic compounds used as a heater casing or for heater terminal seals shall withstand accelerated aging without deteriorating to a degree that would affect its use. Aging conditions, as specified in Table 8.4, are to be based on the temperature rise measured during the temperature and pressure test, Clause 8.6; and defrost test, Clause 8.9.

**Table 8.4 – Accelerated aging test criteria**

Measured temperature rise		Material	Test program
°C	°F		
35	63	Rubber or neoprene	Air oven aging for 70 hours at 100°C ± 2°C (212°F ± 3.6°F)
35	63	Thermoplastic	Aged in an air-circulating oven for 7 days at 100°C (212°F)
50	90	Rubber or neoprene	Air oven aging for 168 hours at 100°C ± 2°C (212°F ± 3.6°F)
50	90	Thermoplastic	Aged in an air-circulating oven for 240 hours at 100°C (212°F)
55	99	Rubber, neoprene or thermoplastic	Aged in an air-circulating oven for 168 hours at 113°C (235.4°F)
65	117	Rubber or neoprene	Aged in an air-circulating oven for 240 hours at 121°C (249.8°F)
65	117	Thermoplastic	Aged in an air-circulating oven for 168 hours at 121°C (249.8°F) or for 1440 hours at 97°C (206.6°F)
80	144	Rubber, neoprene or thermoplastic	Aged in an air-circulating oven for 168 hours at 136°C (276.8°F)
100	180	Rubber, neoprene or thermoplastic	Aged in an air-circulating oven for 1440 hours at 136°C (276.8°F)
125	225	Rubber, neoprene or thermoplastic	Aged in an air-circulating oven for 1440 hours at 158°C (316.4°F)
175	315	Rubber, neoprene or thermoplastic	Aged in an air-circulating oven for 1440 hours at 210°C (410°F)

**8.23 Reliability test – heater terminations**

8.23.1 Electric heaters employing integrally molded leads or molded terminal assemblies shall withstand a force of 89 N (20 pounds-force) applied for 1 minute. The force is to be applied to the leads or terminals in the direction at which they exit the molded connection and shall not result in displacement of insulation or separation of the connection between the lead wire (terminals) and heater wire.

**8.24 Strength tests – pressure containing components**

8.24.1 High-side parts of the refrigeration system shall withstand a pressure at least equal to the highest of the conditions specified in Items (a) – (d):

- a) five times the maximum high-side pressure developed in the temperature and pressure test, Clause 8.6, and defrost test, Clause 8.9;



- b) three times the maximum high-side pressure developed in the condenser fan motor failure test, Clause 8.11;
- c) one and one-half times the vapor pressure of the refrigerant at 60°C (140°F); or
- d) for a unit equipped with a fusible plug, two and one-half times the vapor pressure of the refrigerant at the relief temperature of the fusible plug or two and one-half times the critical pressure of the refrigerant, whichever is smaller.

8.24.2 Low-side parts of the refrigeration system shall withstand a pressure at least equal to the highest of the conditions specified in Items (a) – (d):

- a) three times the maximum low-side pressure developed in the temperature and pressure test, Clause 8.6, including equalization pressure developed after compressor shutdown, and defrost test, Clause 8.9;
- b) three times the maximum low-side pressure developed in the condenser fan motor failure test, Clause 8.11, including equalization pressures after compressor shutdown;
- c) one and one-half times the vapor pressure of the refrigerant at 60°C (140°F); or
- d) for a unit equipped with a fusible plug, two and one-half times the vapor pressure of the refrigerant at the relief temperature of the fusible plug or two and one-half times the critical pressure of the refrigerant, whichever is smaller.

8.24.3 With reference to Clauses 8.24.1(c) and 8.24.2(c), the vapor pressures of R12, R22, R134a, and R717 at 60°C (140°F) are 1427, 2323, 1578, and 2516 kPa (207, 337, 229, and 365 psig), respectively.

8.24.4 With reference to Clauses 8.24.1 and 8.24.2, sections of the refrigerant system constructed of continuous tubing or of lengths of tubing connected by hard-soldered, brazed, or welded joints will be considered as complying with the requirements specified in Clauses 8.24.1 and 8.24.2 provided that the tubing employed in the assembly complies with Clause 7.2.1.

8.24.5 Two samples of each refrigerant-containing part are to be tested to determine compliance with the requirements specified in Clauses 8.24.1 and 8.24.2. The test medium is to be any nonhazardous liquid, such as water. The test samples are to be filled with the test medium to exclude air and are to be connected in a hydraulic pump system. The pressure is to be raised gradually until the required pressure is reached. This pressure is to be maintained for 1 minute during which time the samples shall not burst or leak. Leakage is to be determined visually; for example, by examination of the sample for release of the test medium or as evidenced by a decreasing hydrostatic gauge pressure.

*Exception: If gaskets are employed in components of refrigeration systems employing Refrigerant 12, 22, or 134a, leakage at gaskets is not considered to be a failure provided such leakage occurs at a pressure greater than 40 percent of the required pressure. The component shall not rupture at the required test pressure even though leakage occurs at the gaskets or seals.*

## 8.25 Shelf strength test

8.25.1 A food storage component shall (1) remain in position and (2) comply with Clause 8.25.3 after being subjected to three impacts as indicated in Items (a) and (b). In addition, the test shall not result in exposure of live parts, damage to electrical components or wiring, or reduction of electrical spacings due to the following:

- a) the release from a height of 101.6 mm (4 inches) as measured from the bottom of a bag containing lead shot equal to one-half the mass of the test load specified by Clause 8.25.3, but not exceeding 10 kg (22 pounds); and
- b) if the maximum loading height of the component is less than 254 mm (10 inches), the bag of lead shot is to be released from a height equal to the maximum loading height minus 152.4 mm (6 inches).

*Exception No. 1: This requirement does not apply to refrigerators having a storage capacity of 0.06 m<sup>3</sup> (2 cubic feet) or less.*

*Exception No. 2: This requirement does not apply to food storage components in chest-type units.*

*Exception No. 3: This requirement does not apply to (1) a cover that forms a shelf over a drawer, or (2) a drawer that has a clearance of 50.8 mm (2 inches) or less from a compartment bottom below it.*

8.25.2 The lead shot is to be trade size No. 9 to No. 6, or approximately 2 – 2.8 mm (0.08 – 0.11 inch) in diameter. The bag is to be approximately spherical and is to impact the food-storage component approximately at the center.

8.25.3 A food-storage component shall remain in position and retain a test load applied for 1 hour as follows:

- a) the maximum number of solid steel cylinders, each with a mass of 1 kg (2.2 pounds) with a diameter of 80 mm (3.15 inch), that can be placed in a single tier, axis vertical, on the food-storage component without overhanging the front edge of the component;
- b) if the maximum loading height of a shelf does not exceed 150 mm (5.9 inch), the solid steel cylinders used are to be 80 mm (3.15 inch) in diameter and are to have a mass of 500 grams (1.1 pounds) each;
- c) if necessary, because of the shape of door storage shelves, the solid steel cylinders are to be reduced to a nonoverhanging diameter to adapt them for support by the door shelves. The diameter of the cylinder is to be reduced in increments of 5 mm (0.197 inch). The mass per unit area of the cylinder is to be maintained as specified in Item (a) or (b), as applicable; or
- d) if more than one food-storage component is supported by a bracket (for example, a pilaster arrangement), the bracket shall remain in position when all support components are simultaneously loaded as indicated in Item (a), (b), or (c) as applicable. Adjustable food-storage components shall be approximately equally spaced during this test.

8.25.4 Other loading means may be used in lieu of cylinders, provided the load is equivalent to that calculated on the basis of Clause 8.25.3.

8.25.5 The tests in Clauses 8.25.1 and 8.25.3 are to be conducted with any arrangement or removal of food-storage components, and if the food-storage component or its structural support parts are constructed of polymeric materials, the tests in Clauses 8.25.1 and 8.25.3 are to be conducted at a temperature as specified in Item (a) or (b):

- a) 15 to 32°C (59 to 90°F) for components in the fresh-food storage area; or
- b) minus 17.8±1.5°C (0±2.5°F) for components in the frozen-food storage area. In this case, the components are to be maintained at the test temperature for a period of not less than 24 hours prior to loading.

## 8.26 Component restraint test

8.26.1 A slideout food-storage component (drawer, shelf, or the like) shall be restrained to prevent its being unintentionally pulled free of its supporting means.

8.26.2 The restraint specified in Clause 8.26.1 is acceptable if it will prevent the food storage component from being pulled clear of the refrigerator with the application of a statically applied force equal to the weight of the component loaded in accordance with Clause 8.25.3, but not more than 133 N (30 pounds-force). The component is to be loaded in accordance with Clause 8.25.3 and is to be placed in its restrained position and remain in position. The force is to be applied horizontally by hanging a weight from a cord running over a pulley and attached to the center of the leading edge of the component.

## 8.27 Glass strength test

8.27.1 Glass components, other than lamps, used inside refrigerators shall have smooth edges where exposed to contact during routine use, including cleaning. Additionally, exposed edges with the glass component in its normal storage position shall be fire polished, heat-toughened or tempered, or be covered by permanently attached smooth framing.

8.27.2 Glass components, other than lamps, shall:

- a) be of a nonshattering or tempered type that, when broken, complies with the Safety Performance Specifications and Methods of Test for Glazing Materials Used in Buildings, ANSI Z97.1-1984; or
- b) withstand, without breakage, a 2.2 J (1.6 foot-pound) impact from a 50.8 mm (2 inch) diameter, 0.54 kg (1.18 pound) steel ball. The impact energy is to be imposed on the sample by the steel ball, either falling vertically or by swinging as a pendulum from a height of 413 mm (16.26 inches). The sample component is to be struck within 25.4 mm (1 inch) of its center.

## 8.28 Door latch release test

8.28.1 An interior latch release device shall permit the door to open with a force of 66.7 N (15 pounds-force) or less applied at the rate of 13.3 – 17.8 N/s (3 – 4 pounds-force per second). This test shall be conducted before and after the conditioning specified in Clauses 8.28.4 and 8.28.5.<sup>a</sup>

*Exception: This requirement does not apply to units in which the storage space has a minor dimension of less than 203.2 mm (8 inches) or a volume of less than 0.06 m<sup>3</sup> (2 cubic feet).*

<sup>a</sup>16 CFR 1750

8.28.2 If the test in Clause 8.28.1 is applied to a door with an adjustable spring closing or counterbalancing mechanism, the mechanism is to be adjusted to the position requiring maximum opening force permitted by the design.

8.28.3 The release force measurements shall be made by means of a force gauge at three points on the inside accessible door or door liner edge on the side opposite the hinges. One point shall be near the top of the door, one point near the bottom of the door, and one point midway between these two points. The test shall be conducted with the entire refrigerator in any convenient ambient temperature. The force measurements may be made at points on the outer door surface corresponding to the three internal points.<sup>a</sup>

*Exception: If a force on an interior bar, lever, or similar actuator is required to release the door latch, the force is to be applied to this actuator.*

<sup>a</sup>16 CFR 1750

8.28.4 A refrigerator or combination refrigerator-freezer door shall be subjected to 300,000 cycles of door operation. A freezer door shall be subjected to 150,000 cycles of operation. The door shall be opened sufficiently on each cycle to provide a complete cycle of operation of the latch mechanism. At the conclusion of this test, the latch release device shall comply with the requirements of Clause 8.28.1.<sup>a</sup>

<sup>a</sup>16 CFR 1750

8.28.5 Components of a latch release mechanism that permit the refrigerator door to open as a result of pushing an actuator shall not break, crack, or permanently deform from the application of 50 successive 89 N (20 pounds-force) pushing operations followed by 50 successive 89 N (20 pound-force) pulling operations (if either or both are applicable, depending on the component construction). The test force is to be applied by dropping a 9.1 kg (20 pound) weight 152.4 mm (6 inches).<sup>a</sup>

<sup>a</sup>16 CFR 1750

## **8.29 Door hinge strength test**

8.29.1 After the operation specified in Clause 8.28.4, the hinges of a horizontally swinging exterior refrigerator door shall not separate from the cabinet or door when tested in accordance with Clause 8.29.2.

*Exception: This requirement does not apply to units having a storage volume of 0.06 m<sup>3</sup> (2 cubic feet) or less.*

8.29.2 The door shelves are to be loaded in accordance with Clause 8.25.3. A 34 kg (75 pound) load is then to be applied vertically downward at the edge of the door farthest from the hinges, with the door opened to 15 degrees for 1 hour, and to 90 degrees for 1 hour, from the closed position. If the refrigerator construction provides for change in the door swing from left- to right-hand, and vice versa, the hinge mountings are to be removed and replaced three times on the same side prior to the test. The refrigerator may be counterbalanced to prevent overturning.

### 8.30 Impact test

8.30.1 If an enclosure is used to isolate uninsulated live parts, it shall withstand an impact of 6.8 J (5 foot-pounds) without denting, breaking, or cracking in a manner that would (1) reduce electrical spacings below those specified in Clauses 6.1 and 6.2, or (2) expose uninsulated live parts as judged by the requirements of Clauses 4.4.1 and 4.4.3.

*Exception: If the enclosure is protected because of its location within the confines of the refrigerator, it shall withstand an impact of 2.0 J (1.5 foot-pounds).*

No Text on This Page

8.30.2 If an enclosure is used to provide mechanical protection in accordance with Clauses 4.3.1 – 4.3.7, it shall withstand an impact of 2.0 J (1.5 foot-pounds) without denting, breaking, or cracking in a manner that would expose moving parts as judged by the requirements of assembly, Clause 4.5.

8.30.3 A polymeric functional (structural) part protected because of its location within the confines of the refrigerator shall withstand an impact of 2.0 J (1.5 foot-pounds) without breaking or cracking in a manner that would (1) reduce electrical spacings below those specified in Clauses 6.1 and 6.2, or (2) expose uninsulated live parts as judged by the requirements of Clauses 4.4.1 and 4.4.3.

8.30.4 The impacts are to be produced by a 50.8 mm (2 inch) diameter, 0.54 kg (1.18 pound) steel ball. The ball may be swung through an arc as a pendulum or allowed to fall freely to produce the impact. A vertical distance of 1291 mm (50.8 inches) is required to produce a 6.8 J (5 foot-pound) impact and 387.3 mm (15.25 inches) is needed to produce a 2.0 J (1.5 foot-pound) impact. Three complete as-received samples shall be used for this test. The test is to be conducted at an ambient air temperature of approximately 25°C (77°F). Each sample is to be mounted in its intended position and is to be subjected to a single impact directed at a different location. If the manufacturer so elects, fewer samples may be used if the sample can withstand repeated impacts.

*Exception: If a polymeric enclosure or part is used within a freezer compartment, samples are to be (1) subjected to a temperature of  $18 \pm 1.4^{\circ}\text{C}$  ( $0 \pm 2.5^{\circ}\text{F}$ ) for a period of 3 hours and (2) impacted while still cold.*

## **9 Polymeric Materials – Performance**

### **9.1 Electrical enclosure flammability**

9.1.1 This test is to be conducted on polymeric electrical enclosures using the samples, apparatus, and test method described in the section for enclosure flammability – 5 inch flame test of Polymeric Materials-Use in Electrical Equipment Evaluations, UL 746C, and Evaluation of Properties of Polymeric Materials, CSA Standard C22.2 No. 0.17. Samples of the complete finished part shall be subjected to the test with the flame applied to the interior areas of the part judged as likely to be ignited because of proximity to live or arcing parts, such as coils, wiring, and the like.

9.1.2 The finished part shall not support combustion for more than 60 seconds after the fifth application of the test flame, nor shall it be destroyed to such an extent as to:

- a) reduce electrical spacings below those specified in Clauses 6.1 and 6.2; and
- b) expose uninsulated live parts in line-voltage circuits as determined by the requirements for assembly, Clause 4.5.

## 9.2 Vertical burning test – 5VA, 5VB, materials

9.2.1 This test is to be conducted for the purpose of classifying polymeric materials as 5VA, or 5VB using the samples, apparatus, and test method described for vertical burning test for classifying materials 5VA, or 5VB in the Standard for Tests for Flammability of Plastic Materials for Parts in Devices and Appliances, UL 94, and Evaluation of Properties of Polymeric Materials, CSA Standard C22.2 No. 0.17. Test samples are to be 127 mm (5 inches) long, 12.7 mm (1/2 inch) wide and in the minimum and maximum thicknesses used in the finished part.

## 9.3 Vertical burning test – V-0, V-1, or V-2 solid materials

9.3.1 This test is to be conducted for the purpose of classifying polymeric materials as V-0, V-1, or V-2. The test is to be conducted on specimens obtained from a representative sample of the material using the apparatus and test method described in the vertical burning test for classifying materials V-0, V-1, or V-2 in the Standard for Tests for Flammability of Plastic Materials for Parts in Devices and Appliances, UL 94, and Evaluation of Properties of Polymeric Materials, CSA Standard C22.2 No. 0.17. Test samples are to be 127 mm (5 inches) long, 12.7 mm (1/2 inch) wide, and in the thickness used in the finished part. Two sets of five samples each are required for test.

*Exception: In the case of vacuum-formed parts, test specimens may be selected from the sheet stock prior to forming. The specimens are to be in the minimum thickness of the sheet.*

## 9.4 Horizontal burning test – HB materials

9.4.1 This test is to be conducted for the purpose of classifying polymeric materials as HB. The test is to be conducted on specimens obtained from a representative sample of the material, using the apparatus and test method described in the requirements for the horizontal burning test for classifying materials HB in the Standard for Tests for Flammability of Plastic Materials for Parts in Devices and Appliances, UL 94, and Evaluation of Properties of Polymeric Materials, CSA Standard C22.2 No. 0.17.

9.4.2 Test specimens, 127 mm (5 inches) long, 12.7 mm (1/2 inch) wide and in the thickness of the finished part, are to be provided for this test. The edges of the test specimen are to be smooth.

*Exception: In the case of vacuum-formed parts, test specimens may be selected from the sheet stock prior to forming. The specimens are to be in the minimum thickness of the sheet.*

9.4.3 If specimens of HB materials undergo significant longitudinal shrinkage during the burning test, due to relief of strains or molecular orientation by heat from the burning portion, as may be the case with specimens taken from finished parts, the dimensional change may be taken into account in determining the rate of burning. Measurements may be made of the changes in dimensions of representative specimens of the plastic after annealing between glass plates at an appropriate temperature and a correction for such dimensional changes applied to the observed rate of burning, or the burning tests may be conducted on specimens that have been annealed.



## **9.5 Horizontal burning test – HBF, HF-1, or HF-2 foamed materials**

9.5.1 This test is to be conducted for the purpose of classifying polymeric materials as HBF, HF-1, or HF-2. The test is to be conducted on specimens obtained from a representative sample of the material, using the apparatus and test method described in the horizontal burning test for classifying materials HBF, HF-1, or HF-2 in the Standard for Tests for Flammability of Plastic Materials for Parts in Devices and Appliances, UL 94, and Evaluation of Properties of Polymeric Materials, CSA Standard C22.2 No. 0.17.

9.5.2 Test specimens are to be cut from a representative sample of the material. The specimens are to be 152.4 mm (6 inches) long, 50.8 mm (2 inches) wide, and in the thickness of the finished part but not greater than 12.7 mm (1/2 inch). Edges are to be smooth and the radius on the corners is not to exceed 1.27 mm (0.05 inch). Any loose particles are to be removed from the specimen surfaces.

No Text on This Page

## 9.6 Mold stress-relief test

9.6.1 Conditioning, as described in Clause 9.6.3, of polymeric materials used as enclosures or as functional (structural) parts shall not cause softening of the material as determined by handling immediately after the conditioning, nor shall there be shrinkage, warpage, or other distortion of the enclosure, as judged after cooling to room temperature, that results in any of the conditions specified in Items (a) – (d):

- a) reduction of electrical spacings below those specified in Clauses 6.1 and 6.2;
- b) exposure of uninsulated live parts in line-voltage circuits or moving parts to contact as judged by the requirements of assembly, Clause 4.5;
- c) defeating the integrity of the enclosure or functional part so that acceptable mechanical protection is not afforded to internal parts of the equipment; or
- d) causing interference with the intended operation or servicing of the equipment.

*Exception: This test is not required for rigid thermosetting materials.*

9.6.2 A part subjected to liquid in normal use, where failure of the part could result in the liquid impinging on live parts, shall exhibit no cracking or leaking as determined by visual examination.

9.6.3 One sample of the complete enclosure or part or an appropriate section of the assembly is to be placed in a full-draft air-circulating oven maintained at a uniform temperature at least 10°C (18°F) higher than the maximum temperature of the material measured during the temperature and pressure test, Clause 8.6, or defrost test, Clause 8.9, but not less than 70°C (158°F) in any case. The sample is to remain in the oven for 7 hours. After its removal from the oven and return to room temperature, the sample is to be examined for compliance with Clause 9.6.1.

## 9.7 Fastener strength test

9.7.1 The test is applicable to polymeric materials secured by ultrasonic, solvent, or heat welds; to polymeric screws and nuts; and to metal screws threaded into polymeric materials. The tightening torque and pull-off strength of such fasteners shall be not less than 50 percent of the as-received value.

9.7.2 Three sets of samples, each set consisting of three specimens, shall be conditioned as follows:

Set 1 – As-received (no conditioning).

Set 2 – Oven aging – 300 hours at the service temperature plus 10°C (18°F) but not less than 70°C (158°F). Service temperature is considered to be the temperature measured during the temperature and pressure test, Clause 8.6, and defrost test, Clause 8.9.

Set 3 – Heat cycling – 40 cycles of alternate heating and cooling at the temperatures specified in the following table. Each cycle is to consist of 4 hours at the upper temperature followed by 4 hours at the lower temperature.

Location	Upper Temperature	Lower Temperature
Nonrefrigerated areas	Service temperature plus 10°C (18°F) but not less than 70°C (158°F)	25°C (77°F)
Refrigerator compartment	32°C (90°F)	0°C (32°F)
Freezer compartment	32°C (90°F)	minus 17.8°C (0°F)

## 9.8 Adhesive test

9.8.1 These tests apply to adhesives that are relied on to maintain the integrity of a polymeric enclosure or functional part with regard to the likelihood of a risk of fire, electric shock, or injury to persons. Bond strength shall be considered as the critical property.

9.8.2 The test is to be conducted using the samples, apparatus, and test method described for adhesives in the requirements for Polymeric Materials-Use in Electrical Equipment Evaluations, UL 746C, and Evaluation of Properties of Polymeric Materials, CSA Standard C22.2 No. 0.17.

9.8.3 Table 9.1 is a tabulation of methods commonly used to evaluate adhesion properties.

**Table 9.1 – Commonly used methods to evaluate adhesion properties**

Method evaluation test		Type of material being joined
A.	Shear Strength by Tension Loading (ASTM D1002)	Rigid/Rigid
B.	Tensile Strength by Bar and Rod Samples (ASTM D2095)	Any
C.	Peel Strength by U-Bend Samples (ASTM D903)	Extremely Flexible/Any
D.	Peel Strength by Climbing Drum Apparatus (ASTM D1781)	Flexible/Rigid
E.	Peel Resistance by T Samples (ASTM D1876)	Flexible/Flexible

## 9.9 Flame spread test

9.9.1 The flame spread rating of a polymeric enclosure that exceeds 0.93 m<sup>2</sup>(10 square feet) total area in one plane shall not exceed 75 as determined by the Test for Surface Burning Characteristics of Building Materials, UL 723. See Tables 4.2 and 4.3. As an alternate, the radiant panel method in the Standard Test Method for Surface Flammability of Materials Using a Radiant Heat Energy Source, ASTM E162 can be employed.

*Exception: The material may have a flame spread rating not exceeding 200 if internal ignition sources are enclosed in metal, in a polymeric material that complies with the 127 mm (5 inch) flame test, Clause 9.1, or in a 5V material.*

### 9.10 Volume resistivity test

9.10.1 This test is to be conducted on polymeric materials that (1) enclose uninsulated live parts where electrical spacings between the enclosure and live part are less than required by line-voltage circuits, Clause 6.1, or extra-low voltage (Class 2) circuits, Clause 6.2, or (2) provide indirect or direct support of uninsulated live parts where electrical spacings between the support and live part are less than required by Clause 6.1 or 6.2. The volume resistivity of such materials shall be as specified in Items (a) and (b):

- a) not less than 50 megohm-centimeters after conditioning for 40 hours at  $23\pm 2.0^{\circ}\text{C}$  ( $73.4\pm 3.6^{\circ}\text{F}$ ) and  $50\pm 5$  percent relative humidity; and
- b) not less than 10 megohm-centimeters after exposure for 96 hours to air having a relative humidity of  $90\pm 5$  percent at a temperature of  $35.0\pm 2.0^{\circ}\text{C}$  ( $95.0\pm 3.6^{\circ}\text{F}$ ).

9.10.2 The volume resistivity is to be determined in accordance with requirements for Short Term Property Evaluations of Polymeric Materials, UL 746A, and Evaluation of Properties of Polymeric Materials, CSA Standard C22.2 No. 0.17.

### 9.11 High-current arc ignition test

9.11.1 A polymeric material used to enclose uninsulated live parts or to provide indirect support for such parts shall resist ignition by a high-current arc. See Table 4.3. The material is to be tested in accordance with the requirements for Short Term Property Evaluations of Polymeric Materials, UL 746A, and Evaluation of Properties of Polymeric Materials, CSA Standard C22.2 No. 0.17. There shall be no ignition of:

- a) an enclosure subjected to 60 arcs; and
- b) a functional or structural part subjected to (1) 15 arcs for materials classed as V-0, (2) 30 arcs for materials classed as V-1, or V-2, or (3) 60 arcs for materials classed as HB.

### 9.12 Hot wire ignition test

9.12.1 If a polymeric material is within 12.7 mm (1/2 inch) of electrically-heated wires, resistors, or the like, it shall not ignite in less than 15 seconds if the material is used as an enclosure; or in less than 10 seconds for a V-0 material, 15 seconds for a V-1 material, and 30 seconds for V-2, or HB materials if the material is used as a functional part. The material is to be tested in accordance with the requirements for Short Term Property Evaluations of Polymeric Materials, UL 746A, and Evaluation of Properties of Polymeric Materials, CSA Standard C22.2 No. 0.17. See Table 4.3.

### 9.13 Burnout test – impedance protected motors

9.13.1 This test is to be conducted on impedance protected motors if such motors are not enclosed in metal or in 5V material and are located adjacent to other than 5V polymeric materials. Three samples of the motor are to be tested as described in Clause 9.13.2.

9.13.2 Each motor is to be equipped with a thermocouple for measurement of winding temperatures. The rotor is to be locked. The motor is to be mounted as intended in use, completely wrapped in dry absorbent surgical cotton, and connected to a variable voltage source. The motor is then to be energized at rated voltage and operated until the winding temperature stabilizes. The voltage is then to be progressively increased in 5 V increments, allowing the winding temperature to stabilize after each increase in voltage. Operation is to continue until burnout occurs. There shall be no ignition of cotton surrounding the motor.

9.13.3 As an alternate to testing the individual motor as described in Clause 9.13.2, the test may be conducted on the complete refrigerator. The test arrangement and test method is to be as described in Clause 9.13.2 except that the motor is not to be wrapped in cotton. There shall be no ignition of flammable materials surrounding the motor.

### 9.14 Electrical disturbance test

9.14.1 If HB, or HBF polymeric materials are used in accordance with Exception No. 4 of Clause 4.8.1.4, the material shall not ignite when subjected to electrical disturbance tests in which 22, 27, and 40 A (110, 135, and 200 percent of the rating of the branch circuit overcurrent device) is passed through wires in proximity to the material for periods of 4 hours, 1 hour, and 2 minutes, respectively.

9.14.2 The test is to be conducted in the refrigerator or on a representative section of the refrigerator with a fault introduced in the wiring adjacent to the polymeric material. The wiring is to be prepared by peeling back insulation 12.7 mm (1/2 inch) and removing approximately 80 percent of the wire strands (80 percent of the cross-sectional area for solid conductors) for a distance of 6.4 mm (1/4 inch). The insulation is then to be replaced over the treated section. The wiring is connected in series with a load bank and an electrical supply. Current, as specified in Clause 9.14.1, is caused to flow through the test circuit for the indicated periods of time.

### 9.15 Grounding continuity test

9.15.1 After conditioning as specified in Clause 9.15.2, a grounding connection that relies on the integrity of a polymeric part shall have a resistance of not more than 150 percent of the as-received value. In any case, the resistance of the connection shall not exceed 0.1 ohm.

9.15.2 Five sets of the connection, each set consisting of three samples, are to be provided for test. If the connection is secured by a threaded fastener, it is to be tightened to the manufacturer's production specification. Connection resistances are to be measured after conditioning as follows:

Set 1 – As-received (no conditioning).

Set 2 – Oven aging – 1000 hours at the service temperature plus 10°C (18°F) but not less than 35°C (95°F). Service temperature is considered to be the temperature measured during the temperature and pressure test, Clause 8.6, and defrost test, Clause 8.9.

Set 3 – Oven aging – 7 hours at 70°C (158°F).

Set 4 – Heat cycling – 40 cycles of alternate heating and cooling at the temperatures specified in the following table. Each cycle is to consist of 4 hours at the upper temperature followed by 4 hours at the lower temperature.

No Text on This Page



Location	Upper temperature	Lower temperature
Nonrefrigerated areas	Service temperature plus 10°C (18°F) but not less than 35°C (95°F)	25°C (77°F)
Refrigerator compartment	32°C (90°F)	0°C (32°F)
Freezer compartment	32°C (90°F)	minus 17.8°C (0°F)

Set 5 – Current overload – A current of 40 A (for 120 V units) or 30 A (for 208 or 240 V units) passed through the connection for 2 minutes.

### 9.16 Distortion test

9.16.1 There shall be no distortion of adjacent combustible material when a lamp is operated for 30 minutes with the refrigerator door open and no refrigeration. The wattage rating of the lamp shall be that recommended by the manufacturer.

### 9.17 Heating test – condensate wiring

9.17.1 Where required by Clause 4.10.1.4, the temperature measured on the insulation of a resistance type heater wire used to prevent condensation in a refrigerator shall not exceed its recognized temperature limit when tested under the conditions outlined in Clause 9.17.2.

9.17.2 To determine compliance with the requirements of Clause 9.17.1, the heater shall be energized at the test voltage (see Clause 8.2.1) until constant temperatures, as measured by thermocouples on the insulation, are attained. The test is to be conducted at approximately 25°C (77°F) ambient temperature with the refrigerator in the OFF position.

## 10 Manufacturing and Production Tests

### 10.1 Pressure tests

10.1.1 Each refrigerator shall be tested and proved tight at not less than the design pressure as determined during the temperature and pressure test, Clause 8.6, nor less than the following:

Refrigerant	Minimum Design Pressure, kPa (Psia) <sup>a</sup>	
	Low-side	High-side
12	690 (100)	1269 (184)
22	1097 (159)	2021 (293)
123	207 (30)	228 (33)
134a	710 (103)	1386 (201)
401 (53/13/34)	690 (100)	1359 (197)
401 (61/11/28)	745 (108)	1448 (210)
402 (38/2/60)	1276 (185)	2338 (339)
402 (60/2/38)	1366 (198)	1932 (288)
500	807 (117)	1503 (218)
502	1221 (177)	2186 (317)
717	958 (139)	2020 (293)

<sup>a</sup> Psia pressure based on conversion of 0 (Zero) psig = 15 psia

For other refrigerants, the minimum design pressure shall not be less than the values recorded during the temperature and pressure test, Clause 8.6, nor less than the saturation pressure of the refrigerant at the following temperatures:

- a) 26.5°C (80°F) for low sides; and
- b) 51.7°C (125°F) for air cooled high sides.

*Exception: A method other than pressure testing at the design pressure may be employed if it can be demonstrated that the alternate test method produces results that are at least equivalent to the pressure test method.*

10.1.2 If the final assembly is completed with flare-type fittings or telescoped tubing joints that are sealed with silver solder, brazing, or the equivalent, pressure test of the complete system may be at the low-side design pressure provided that the high-side parts are individually tested either by the refrigerator manufacturer or by the manufacturer of the part at not less than the high-side design pressure.

10.1.3 At least once each year, a strength test shall be conducted on refrigerant-containing parts of the shell type that have an inside diameter greater than 76.2 mm (3 inches) including motor-compressor enclosures. The tests shall be conducted on at least one sample of each size and type. The part shall comply with the requirements indicated under strength tests – pressure containing components, Clause 8.24. Such tests may be conducted either by the refrigerator manufacturer or by the manufacturer of the component.

## 10.2 Production line dielectric voltage-withstand tests

10.2.1 Each product shall withstand without electrical breakdown, as a routine production-line test, the application of a potential at a frequency within the range of 40 – 70 hertz, or a dc potential

- a) Between the primary wiring, including connected components, and accessible dead metal parts that are likely to become energized; and
- b) Between primary wiring and accessible extra-low-voltage, 42.4 volts peak or less, metal parts, including terminals.

10.2.2 The production-line test shall be conducted in the time and at the potential specified in either Condition A or Condition B of Table 10.1.

**Table 10.1 – Production-line test conditions**

Product rating	Condition A			Condition B		
	Potential, volts ac <sup>c</sup>	volts dc	Time, seconds	Potential, volts ac <sup>c</sup>	volts dc	Time, seconds
250 volts or less with no motor rated more than 1/2 horsepower (373 watts output)	1000	1400	60	1200	1700	1
250 volts or less with a motor rated more than 1/2 horsepower (373 watts output)	$1000 + 2V^a$	$1400 + 2.8V^a$	60	$1200 + 2.4V^a$	$1700 + 3.4V^a$	1
251 – 600 volts	$1000 + 2V^b$	$1400 + 2.8V^b$	60	$1200 + 2.4V^b$	$1700 + 3.4V^b$	1
<p><sup>a</sup> Maximum marked voltage but not less than 120 volts if the maximum marked voltage is within the range 105 – 120 volts, and not less than 240 volts if the maximum marked voltage is within the range 210 – 240 volts.</p> <p><sup>b</sup> Maximum marked voltage.</p> <p><sup>c</sup> Where there are capacitors across the insulation under test (e.g radio-frequency filter capacitors), it is recommended that direct-current test voltages are used.</p>						

10.2.3 For equipment employing extra-low-voltage circuits, the test is to be conducted with the extra-low-voltage circuit connected to the cabinet, chassis, or other dead metal part so that the potential applied between the line-voltage live parts and dead metal parts will simultaneously be applied between line-voltage live parts and extra-low-voltage circuits.

10.2.4 The test shall be conducted when the product is fully assembled. It is not intended that the product be unwired, modified, or disassembled for the test.

*Exception No. 1: A part, such as a snap cover or friction-fit knob, that would interfere with performance of the test need not be in place.*

*Exception No. 2: The test may be performed before final assembly if the test represents that for the completed product. Any component not included shall not affect the results with respect to determination of possible risk of electric shock resulting from miswiring, defective component, insufficient spacings, and the like.*

10.2.5 Solid-state and similar components that might be damaged by a secondary effect (induced voltage surge, excessive heating, and the like), of the test may be short-circuited by means of a temporary electrical jumper or the test may be conducted electrically connected, providing the wiring and terminal spacings are maintained. Additionally, components providing a direct-current path in parallel with the insulation to be tested (primary to dead-metal) may be disconnected during the test. Examples of such components are discharge resistors for filter capacitors and voltage limiting devices such as transient voltage suppressors (other than capacitors).

10.2.6 The test equipment shall have a means of:

- a) Indicating the test potential,
- b) An audible or visual indicator of electrical breakdown, and
- c) Either a manually reset device to restore the equipment after electrical breakdown or an automatic reject feature of any noncomplying unit.

When an ac test potential is applied, the test equipment shall include a transformer having an essentially sinusoidal output.

10.2.7 If the output of the test-equipment transformer is less than 500 volt-amperes, the equipment shall include a voltmeter in the output circuit to directly indicate the test potential.

10.2.8 If the output of the test-equipment transformer is 500 volt-amperes or more, the test potential may be indicated:

- a) By a voltmeter in the primary circuit or in a tertiary-winding circuit;
- b) By a selector switch marked to indicate the test potential; or
- c) For equipment having a single test-potential output, by a marking in a readily visible location to indicate the test potential. If a marking is used without an indicating voltmeter, the equipment shall include a positive means, such as an indicator lamp, to indicate that the manually reset switch has been reset following a dielectric breakdown.

10.2.9 Test equipment other than that described in the preceding paragraphs may be used if determined to accomplish the intended factory control.

10.2.10 During the test,

- a) The primary switch is to be in the on position,
- b) Both sides of the primary circuit of the product are to be connected together and to one terminal of the test equipment, and
- c) The second test-equipment terminal is to be connected to accessible dead metal.

*Exception: A product having circuitry that is resistive, high-impedance winding, or the like and is not subject to excessive secondary-voltage build-up in case of electrical breakdown during the test may be tested:*

- a) With a single-pole primary switch, if used, in the off position; or*
- b) With only one side of the primary circuit connected to the test equipment when the primary switch is in the on position or when a primary switch is not used.*

### **10.3 Production line grounding continuity test**

10.3.1 The manufacturer shall test each refrigerator that has a power-supply cord to determine that electrical continuity exists between the appliance and the grounding blade of the attachment-plug cap.

10.3.2 An indicating device, such as an ohmmeter, low-voltage battery- and buzzer-combination, or the like, may be employed in the test mentioned in Clause 10.3.1.

## **11 Marking**

*Advisory Note: In Canada, there are two official languages, therefore, it is necessary to have CAUTION, WARNING, and DANGER markings in both English and French. Acceptable translations are provided in Appendix B for the markings specified in this Standard. When a product is not intended for use in Canada, cautionary markings may be provided in English only.*

### **11.1 General**

11.1.1 A marking that is required to be permanent shall be molded, die-stamped, paint-stenciled, stamped, or etched metal that is permanently secured, or indelibly stamped on pressure-sensitive labels secured by adhesive. Pressure-sensitive labels and adhesive shall comply with the Standard for Marking and Labeling Systems, UL 969, and the Standard for Adhesive Labels, CSA Standard C22.2 No. 0.15.

11.1.2 Each refrigerator shall be permanently marked with the following:

- a) the manufacturer's or private labeler's name or identifying symbol;
- b) a distinctive type or model designation;
- c) the electrical rating. See Clause 11.1.3;
- d) the kind and amount of refrigerant. See Clause 11.1.6; and
- e) the date of manufacture that will enable the product to be identified as being manufactured within a consecutive 3-month period. This information may be in code and shall be located on or near the nameplate. A date code marking shall be such that it does not repeat in less than 10 years.

11.1.3 Refrigerators shall be marked with the operating voltage, frequency, and total load in amperes. The marked ampere rating shall include all individual loads that may operate concurrently. Permanently-connected units shall also be marked with the number of phases.

*Exception: If a refrigerator incorporates an electric defrost heater, the defrost load in amperes may be marked in addition to the refrigeration load or, if the defrost load exceeds the refrigeration load, only the larger load need be marked.*

11.1.4 A refrigerator that requires its supply circuit to be protected by a time delay fuse to permit starting, operation, or defrosting (see Clause 8.7.3) shall be visibly marked with the following, or equivalent wording:

IF CONNECTED TO A CIRCUIT PROTECTED BY FUSES, USE TIME DELAY FUSE.

11.1.5 There shall be replacement marking adjacent to each fuse or fuseholder that is intended to reduce the risk of fire. The marking shall be readily visible during replacement of the fuse, and shall consist of the word "CAUTION" and the following or the equivalent: "To reduce the risk of fire, replace only with same type \_\_\_\_\_ fuse." The rating of the fuse is to be marked in the blank space. For a fuse that is soldered in place and is perceptible during user servicing, the marking shall also include the following or the equivalent: "To be replaced only by qualified service personnel."

11.1.6 The kind of refrigerant shall be designated by number according to the Standard for Number Designation and Safety Classification of Refrigerants, ANSI/ASHRAE 34-1992. The number shall be prefixed or suffixed with the word "Refrigerant" or it shall be prefixed with the letter "R" or the trade name of the refrigerant. Combinations of these marks are acceptable, with the exception of employing the letter "R" and the word "Refrigerant" in the same marking group. Examples of refrigerant marking are as follows: R 12, Refrigerant 12, or 12 Refrigerant, (Trade Name) 12, (Trade Name) RISK, or (Trade Name) 12 Refrigerant.

11.1.7 The information specified in Clause 11.1.2 shall be on a nameplate(s) that can be read without requiring the use of tools, removal of panels, or the like.

11.1.8 The information specified in Clause 11.1.2 shall be located so that it can be read after installation of the appliance.

11.1.9 A refrigerator that is intended only for freestanding installation shall have a legible marking on or in the vicinity of the nameplate, with letters not less than 4.8 mm (3/16 inch) high, reading: "Free-Standing Installation Only."

11.1.10 A refrigerator that has been evaluated for recessed or built-in installation and tested with the enclosure spaced from the refrigerator shall have a legible marking, on or in the vicinity of the nameplate, specifying the minimum installation clearances to be maintained.

*Exception: A refrigerator that has been evaluated for recessed or built-in installation and tested with zero clearances on the top, back, and sides need not be so marked.*

11.1.11 With reference to Clauses 11.1.9 and 11.1.10, a paper sticker glued, shellacked, or both, to the unit, or an ink stamp is acceptable.

11.1.12 An electrical accessory intended for field installation in or on a refrigerator shall be permanently marked with the name or identifying symbol of the manufacturer or private labeler, and with a catalog number or equivalent designation. The identification shall be on the accessory or the carton in which it is shipped. The associated refrigerator shall be marked to indicate the catalog number or equivalent designation of such an accessory and the name of the manufacturer or private labeler of that accessory if other than the refrigerator manufacturer.

11.1.13 With regard to Clause 11.1.12, instructions for installing the accessory shall be provided on or with the accessory. A statement shall be included in the instructions warning the installer that the refrigerator must be disconnected from the source of electrical supply before attempting the installation and that the accessory is intended for use only with a refrigerator that is marked to indicate such use.

*Exception: If the accessory is designed to be installed by means of receptacles and plug-in connectors that have been investigated to make and break circuits under load, and if such connection or disconnection does not result in exposure of uninsulated live parts, the statement that the appliance must be disconnected from the source of electrical supply need not be employed.*

11.1.14 If a manufacturer produces refrigerators at more than one factory, each unit shall have a permanent distinctive marking to identify it as the product of a particular factory.

11.1.15 With regard to Clause 4.7.7(d), a lock key shall be permanently marked with the word "CAUTION" and with the following or equivalent statement:

"To Prevent A Child From Being Entrapped, Keep Out Of Reach Of Children And Not In The Vicinity Of Freezer (Or Refrigerator)."

A marking calling attention to the notice above shall be placed over the key slot of the lock or immediately adjacent to it. This marking may be removable.

11.1.16 Unless correct field-wiring connections are obvious, a wiring diagram shall be attached to each permanently-connected refrigerator to show the intended method of making field-wiring connections. A paper sticker, cemented to an accessible cover, is considered as complying with this requirement.

11.1.17 A refrigerator with field wiring terminals shall be marked:

- a) "Use Copper Conductors Only" if the unit is not intended for field connection with aluminum wire; or
- b) "Use Copper Or Aluminum Conductors", "Use Copper Or Copper-Clad Aluminum Conductors", or "Use Copper, Copper-Clad Aluminum, or Aluminum Conductors" if the unit is intended for field connection with either copper or aluminum wire.

In either case, an equivalent statement that identifies the proper wiring material may be used. The marking shall be independent of any marking on the terminal connector and may appear on an attached wiring diagram. The marking shall be visible during installation of the unit and also when the terminals are exposed for inspection after the unit has been installed.

11.1.18 With regard to Exception No. 2 of Clause 4.9.1.5, the statement "CAUTION, DO NOT USE EXTENSION CORD" or equivalent shall also appear on the refrigerator in order to use a power supply cord less than 1.5 m (5 feet) long.

11.1.19 With regard to the Exception to Clause 4.9.2.4, if an ac/dc refrigerator is intended for simultaneous connection to the power supplies and disconnection from one supply does not result in automatic de-energization of all circuits within the unit, it shall be permanently marked with the word "CAUTION" and with the following or equivalent wording: "Risk of electric shock. More than one power supply. Disconnect all power supplies before servicing."

11.1.20 The warning marking indicated in Clause 11.1.19 shall be in letters no less than 3.2 mm (1/8 inch) high and shall be located so as to be visible before or immediately upon removal of a cover, panel, or the like, which encloses or protects uninsulated live parts. The marking shall not be on the back of a removable cover or panel.



11.1.21 With respect to Clause 11.1.20, if the marking is located on the front of a removable panel or cover, the design of the panel or cover or its means of attachment shall be such that the panel cannot be reversed or inverted when it is replaced so as to obscure the warning.

11.1.22 With reference to Clause 5.5.1, a refrigerator provided with a lamp rated more than 150 V shall have a legible marking on or in the vicinity of the nameplate indicating that it is intended for use only where 250 V incandescent lamps are used for general household lighting.

11.1.23 A refrigerator marked in accordance with Clause 11.1.22 shall also be marked: "Replace lamp with 250 V lamp only." This marking shall be readily visible to the user during relamping.

No Text on This Page

11.1.24 With reference to Clauses 11.1.22 and 11.1.23, the marking shall be in letters not less than 4.8 mm (3/16 inch) high.

11.1.25 A refrigerator shall be permanently marked with the maximum rating of the lamp as determined by Clause 9.16.1. The marking shall appear on or adjacent to the lampholder.

11.1.26 When a refrigerator is intended to be disassembled by means of a tool for the purpose of cleaning or servicing by the user, when instructed by the manufacturer, and when such disassembly involves the exposure of persons to unintentional contact with any otherwise enclosed or protected moving part, hot part, or uninsulated live part, the refrigerator shall be permanently marked with the word "DANGER" or "WARNING" or "CAUTION" and the applicable statement(s) indicated in Table 11.1. The marking shall be in letters no less than 1/8 inch (3.2 mm) high and shall be located so as to be visible before or immediately upon removal of a cover, panel, or similar device that encloses or protects the moving part, hot part, or live part. The marking shall not be on the back of a removable cover or panel.

**Table 11.1**

<b>Moving parts</b>	<b>Uninsulated live parts</b>	<b>Hot parts</b>
Moving parts. Do not Operate Unit with <u>a</u> Removed	Risk of Electric Shock. Disconnect Power Before Servicing Unit	Hot Parts. Do Not Operate Unit With <u>a</u> Removed
<sup>a</sup> Specify appropriate part.		

## 11.2 Installation and operating instructions

11.2.1 A refrigerator shall be provided with installation and operating instructions. The instructions shall contain directions and information that the manufacturer considers necessary for installation, use, and user maintenance of the refrigerator.

11.2.2 A copy of the manufacturer's instructions, or equivalent information, intended to accompany each refrigerator is to be furnished with the sample submitted for investigation. These instructions are to be used as a guide in the examination and test of the refrigerator. For this purpose, a printed edition is not required initially if rough draft instructions or information as to what the instructions will include are submitted for review as part of the investigation.

11.2.3 The mounting hardware and installation instructions for a wall-hung refrigerator shall be shipped with the refrigerator.

11.2.4 Instructions for cord-connected refrigerators shall include the manufacturer's recommendations regarding the use of extension cords. If use of an extension cord is not recommended, the instructions shall state this. Recommendations for the use of an extension cord shall specify at least the use of an extension cord with an equipment grounding conductor, grounding-type attachment plug, and grounding-type connector (load fitting); and the ampacity and voltage rating of the extension cord. These recommendations may be provided in or with other instructions accompanying the refrigerator; or may be in the form of an ink stamping or a decal, paper label, or the like secured by adhesive to the cabinet.

11.2.5 A child entrapment warning statement shall be included in either the operating instructions or in a use an care manual provided with each refrigerator.

11.2.6 The child entrapment warning statement shall include the following or equivalent wording:

DANGER: Risk of child entrapment. Before you throw away your old refrigerator or freezer:

- Take off the doors
- Leave the shelves in place so that children may not easily climb inside.

## **SUPPLEMENT SA - REQUIREMENTS FOR REFRIGERATORS AND FREEZERS EMPLOYING A FLAMMABLE REFRIGERANT IN THE REFRIGERATING SYSTEM**

### **SA1 Scope**

SA1.1 These requirements cover household refrigerators and freezers that employ a refrigerant that has been identified as having flammable characteristics.

SA1.2 These requirements do not apply to household refrigerators and freezers that employ ammonia as the refrigerant.

SA1.3 The requirements in this supplement are in addition to the applicable requirements in the Standard for Household Refrigerators and Freezers, UL 250/CSA C22.2 No. 63.

### **SA2 Definitions**

SA2.1 **Protected Cooling System** – A system in which:

- a) All refrigerant tubing and refrigerant containing components are located external to the refrigerated compartment, or
- b) Any part of a rollbond type cooling system, which is located inside a refrigerated compartment, is constructed so that the refrigerant is contained within an enclosure with at least two layers of metallic materials separating the refrigerant from the refrigerated compartment. The enclosure has no joints other than the bonded seams of the evaporator where the bonded seam has a width of at least 6 mm (0.24 in.), or
- c) Any part of the cooling system which is located inside a refrigerated compartment has the refrigerant contained in an enclosure which itself is contained within a separate protective enclosure. If leakage from the containing enclosure occurs, the leaked refrigerant is contained within the protective enclosure and the appliance will not function as in normal use. The protective enclosure contains no joints within the refrigerated compartment, or
- d) All parts of the cooling system are located within a refrigerated air handling compartment. This compartment separates all refrigerant containing components from the food storage compartment.

SA2.2 **Unprotected Cooling System** – A refrigeration system where refrigerant tubing or refrigerant containing components are located inside the food storage compartment, and these parts do not have additional protection as defined in SA2.1 (b), (c) or (d).

SA2.3 **Refrigerated Compartment** – The internal portion of the refrigerator which contains the refrigerated air. A food storage compartment and an air handling compartment can be separate parts of the refrigerated compartment.

SA2.4 **Ignition Source** – Any electrical switching component. Heaters, motors, etc. that comply with the temperature test requirements in SA5.3 are not considered ignition sources.

SA2.5 **Critical Points** – Interconnecting joints between parts of the refrigeration circuit.

SA2.6 **Dead Space** – A space with a bottom and sides with no intentional air flow that could contain a leaked quantity of refrigerant as determined by testing in Section SA5.

### SA3 General

SA3.1 Refrigerants are categorized for toxicity as either lower toxicity or higher toxicity in accordance with the Standard for Number Designation of Refrigerants, ANSI/ASHRAE 34. Refrigerants intended for use in household refrigerators and freezers shall be in the lower toxicity group, Group A.

SA3.2 Refrigerants shall be evaluated for flammability in accordance with the Standard for Refrigerants, UL 2182.

SA3.3 The charge size for refrigerators or freezers shall be as follows for the kind of refrigerant used:

- a) No charge limit - Has no limits of flammability, has either an autoignition temperature less than or equal to 750°C (1382°F) or no autoignition temperature.
- b) No charge limit - When the blend complies with the exception to SA3.4.
- c) 225 grams (8.0 oz) - Has limits of flammability, and heat of combustion less than 19,000 kJ/kg (8,174 Btu/lb). When the leaked amount of refrigerant during leak scenario testing of the refrigerating system, does not exceed 225 grams (8.0 oz), a larger amount of charge is not prohibited from being used.
- d) 50 grams (1.7 oz) - Has limits of flammability and heat of combustion greater than 19,000 kJ/kg (8,174 Btu/lb). When the leaked amount of refrigerant during leak scenario testing of the refrigerating system does not exceed 50 grams (1.7 oz), a larger amount of charge is not prohibited from being used.

SA3.4 Refrigerant blends with a flammable component that fractionate due to a system leak which results in a change in flammability, shall be treated according to their worst case classification.

*Exception: Refrigerant blends that do not fractionate into a flammable mixture, as determined by fractionation testing, (1) within the refrigerating system during operation of the refrigerator and freezer or during standby conditions, (2) as a result of a system leak, and (3) during a charge-recharge scenario are determined to be blends that do not have limits of flammability.*

SA3.5 Refer to Section 4.8 for requirements regarding the use of thermal insulating foam with a flammable blowing agent.

SA3.6 Protective enclosures shall withstand the Strength Test in Section 8.24.

## SA4 CONSTRUCTION

### SA4.1 General

SA4.1.1 The overall design of the refrigerator shall be such that there are no dead spaces where a leaked refrigerant that is heavier than air can accumulate and be ignited by an external ignition source.

*Exception: The spaces described in Items (a) – (d) need not comply with the above requirement:*

- a) a drawer in the refrigerated compartment;*
- b) the refrigerated compartment of a chest type freezer where all refrigerant containing parts are located external to the refrigerated compartment;*
- c) condensate pans, drain tubes, and the like, with a volume of less than 0.014 m<sup>3</sup> (0.5 ft<sup>3</sup>); or*
- d) spaces where the accumulated leaked refrigerant under a leak condition will not exceed 50 percent of the lower flammable limit of the refrigerant by volume percent as specified in Table SA5.1.*

SA4.1.2 Refrigerant tubing shall be protected or enclosed to avoid mechanical damage. The tubing shall be protected to the extent that it will not be grasped or handled during moving of the product. Tubing located within the confines of the cabinet is considered to be protected from mechanical damage.

### SA4.2 Valves/Fittings

SA4.2.1 A refrigerator or freezer that employs a flammable refrigerant shall not employ quick connect fittings, flare fittings, compression fittings, or packed stem valves.

SA4.2.2 All joints in the refrigeration system containing a flammable refrigerant shall be brazed or welded and shall be located within the confines of the overall enclosure.

*Exception: Joining methods that have been evaluated with respect to corrosion resistance, mechanical stress, leak rates, and similar methods are not required to comply.*

### SA4.3 Resistance to Corrosion

SA4.3.1 The refrigeration system containing a flammable refrigerant shall be protected against corrosion, see clause 7.2.2.

## SA5 PERFORMANCE

### SA5.1 Leakage Test

SA5.1.1 Refrigerators and freezers shall be constructed so that leaked refrigerant will not accumulate near ignition sources and dead spaces in quantities that exceed the volume percent of the refrigerant as noted in Clauses SA5.1.2.7, SA5.1.3.7 or SA5.1.4.5. Compliance is to be determined by means of the tests in Clauses SA5.1.2, SA5.1.3, and SA5.1.4. See also Clause SA4.1.1.

*Exception No. 1: Refrigerators employing switching components that comply with the ignition test, Clause SA5.2 need not comply with this requirement.*

*Exception No. 2: Inherent motor protectors located in the windings of a motor (excluding the compressor overload protector) need not comply with this requirement.*

SA5.1.2 Refrigerators and freezers with a protected cooling system are tested in accordance with the following:

SA5.1.2.1 Refrigerant leakage is to be simulated at the most critical point of the cooling system. The method for simulating a leakage at the most critical point is to inject the refrigerant vapor through a capillary tube at a joint which may need to be positioned before foaming the appliance. The capillary tube shall have a diameter of 0.7 mm  $\pm$  0.05 mm and a length between 2 m and 3 m. More than one test may be necessary to find the most critical point of the cooling system.

SA5.1.2.2 During this test the appliance is to be tested with doors and lids closed, and is switched off or operated whichever gives the most unfavorable results.

SA5.1.2.3 During a test in which the appliance is operated, refrigerant vapor injection is to be started at the same time as the appliance is first switched on.

SA5.1.2.4 The quantity of refrigerant of the type indicated by the manufacturer to be injected is equal to 80% of the nominal charge of the refrigerant or the maximum which can be injected in one hour, whichever is the smaller.

SA5.1.2.5 The quantity injected is to be taken from the vapor side of a refrigerant container which shall contain a sufficient quantity of liquid refrigerant to ensure that at the end of the test there is still liquid refrigerant remaining in the container. The refrigerant container is to be kept at a temperature of 32°C  $\pm$  1°C (89  $\pm$  1.8°F) for leakage simulation of low-side pressure circuits and 70°C  $\pm$  1°C (158  $\pm$  1.8°F) for leakage simulation of high-side pressure circuits. If the test refrigerant is a blend, care is to be taken to ensure that the refrigerant does not separate during the test.



SA5.1.2.6 The concentration of leaked refrigerant inside the food storage compartments and inside any internal or external electrical component compartment is to be measured continuously from the beginning of the test and for at least one hour after the injection of the refrigerant vapor has stopped. The instrument used for monitoring the refrigerant concentration, such as gas chromatography which uses infrared sensing techniques, should have a fast speed of response (typically 2 or 3 seconds) and not influence the result of the test.

SA5.1.2.7 The measured value shall not exceed 75% of the lower flammable limit of the refrigerant as specified in Table SA5.1 and also shall not exceed 50% of the lower flammable limit of the refrigerant as specified in Table SA5.1 for a period exceeding 5 min, otherwise the appliance shall be considered as having an unprotected cooling system and it shall comply with sub-clause SA5.1.3.

SA5.1.3 Refrigerators and freezers with an unprotected cooling system, are to be tested in accordance with the following:

SA5.1.3.1 The test is to be performed in a draft-free location with the appliance switched off or operated, whichever gives the most unfavorable result. During a test in which the appliance is operated, refrigerant vapor injection is started at the same time as the appliance is first switched on. The test is repeated three times.

SA5.1.3.2 Through an appropriate orifice, 80% of the nominal refrigerant charge in the vapor state is to be injected into a food storage compartment within 10 min, the orifice is then closed. The injection shall be as close as possible to the center of the back wall of the compartment at a distance from the top of the compartment approximately 1/3 of the height of the compartment. Thirty minutes after the injection is completed, the door or lid is opened to an angle of 90° at a uniform rate in a time between 2 and 4 seconds.

SA5.1.3.3 For appliances having more than one door or lid, the most unfavorable sequence or combination of opening the lids or doors is to be used.

SA5.1.3.4 For appliances fitted with a motor(s) the test is to be done with the most unfavorable combination of motor operation.

SA5.1.3.5 The concentration of leaked refrigerant close to the electrical components and in dead spaces is to be measured continuously from the beginning of the test. The concentration values are to be recorded until they go down.

SA5.1.3.6 The measured value shall not exceed 75% of the lower flammable limit of the refrigerant as specified in Table SA5.1 and also shall not exceed 50% of the lower flammable limit of the refrigerant as specified in Table SA5.1 for a period exceeding 5 min.

SA5.1.3.7 The above test is to be repeated except that the door or lid is subjected to an open/close sequence at a uniform rate in a time of between 2 and 4 seconds, with the door or lid being opened to an angle of 90° during the sequence.

SA5.1.4 Refrigerant leakage outside the food storage area is to be tested in accordance with the following:

SA5.1.4.1 The test is to be performed in a draft free location with the appliance switched off or operated, whichever gives the most unfavorable result. During a test in which the appliance is operated, refrigerant vapor injection is to be started at the same time as the appliance is first switched on.

SA5.1.4.2 A quantity equal to 80% of the refrigerant charge is to be injected into the specified area.

SA5.1.4.3 Injection is to be at a constant rate over a period of one hour and is to be at the point of closest approach of joints in external parts of the cooling circuit to the electrical components under consideration, any direct injection shall be avoided.

SA5.1.4.4 The concentration of leaked refrigerant close to the electrical components and in dead spaces is to be measured continuously from the beginning of the test until it starts to decrease.

SA5.1.4.5 The measured value shall not exceed 75% of the lower flammable limit of the refrigerant as specified in Table SA5.1 and shall also not exceed 50% of the lower flammable limit of the refrigerator as specified in Table SA5.1 for a period exceeding 5 min.

## **SA5.2 Ignition test**

SA5.2.1 This test is to be conducted on switching components that are exposed to the flammable refrigerant as detailed by Clause SA5.1.1. The test determines if the components will ignite the specific flammable refrigerant under consideration.

SA5.2.2 The test shall be conducted in accordance with the test procedures described in the Standard Test Method for Concentration Limits of Flammability of Chemicals (Vapors and Gases), ASTM E681-98, except that the component shall be used as the ignition device. The component shall be connected to its rated load. Components which comply with the requirements of Section 3 clause 16 and Section 4 of IEC 60079-15 (for Group II A gases or the flammable refrigerant) or UL 1604, Electrical Equipment for Use in Class I and II, Division 2, and Class III Hazardous (Classified) Locations are considered to comply with this requirement.

SA5.2.3 The test is to be conducted at room ambient and at 50°C (122°F).

SA5.2.4 The number of trials for ignition shall be fifty after a preconditioning cycling of 6000 trials at rated load.

SA5.2.5 The component is to be placed in a stoichiometric mixture of air/leaked refrigerant.

### SA5.3 Temperature test

SA5.3.1 Surface temperatures of parts that may be exposed to a leaked refrigerant shall not exceed the ignition temperature of the refrigerant as specified in Table SA5.1, reduced by 100°C (180°F). See Clauses 8.6 (Temperature and pressure test) and 8.9 (Defrost test) for test methods.

*Exception No. 1: Parts that do not ignite the leaked refrigerant as determined by ignition tests, need not comply with the above requirement.*

*Exception No. 2: Defrost heaters, when the refrigerant under any leak condition (see Leakage test, SA5.1) will not contact the heater in quantities, volume percent, that exceed 50 percent of the lower flammable limit of the refrigerant, need not comply with the above requirement.*

SA5.3.2 In regards to Clause SA5.3.1 glass tube defrost heaters may be employed if the element temperature does not exceed the ignition temperature of the refrigerant as specified in Table SA5.1 reduced by 100°C(180°F).

**Table SA5.1**  
**Refrigerant flammability parameters**

Refrigerant number	Refrigerant name	Refrigerant formula	Refrigerant ignition temperature <sup>a</sup> °C	Refrigerant lower flammable limit % v/v <sup>b,c</sup>
R50	Methane	CH <sub>4</sub>	645	4.9
R290	Propane	CH <sub>3</sub> CH <sub>2</sub> CH <sub>3</sub>	470	2.1
R600	n-Butane	CH <sub>3</sub> CH <sub>2</sub> CH <sub>2</sub> CH <sub>3</sub>	365	1.5
R600a	Isobutane	CH(CH <sub>3</sub> ) <sub>3</sub>	460	1.8

<sup>a</sup>Values for other flammable refrigerants can be obtained from IEC 60079-4A and IEC/TR3 60079-20.  
<sup>b</sup>Values for other flammable refrigerants can be obtained from EN 50054 or ANSI/NFPA 325-1994.  
<sup>c</sup>Concentration of refrigerant in dry air.

**NOTE: UL 340, Standard for Tests for Comparative Flammability of Liquids and ASTM E659-78 (1994) e1, Standard Test Method for Autoignition Temperature of Liquid Chemicals are similar (not identical) to IEC 60079-4A, Method of Test for Ignition Temperature.**

### SA5.4 Scratch test

SA5.4.1 All accessible surfaces of protected cooling system components, including accessible surfaces in intimate contact with a protected cooling system, are scratched using the tool shown in figure SA5.1.

Figure SA5.1  
Scratching tool

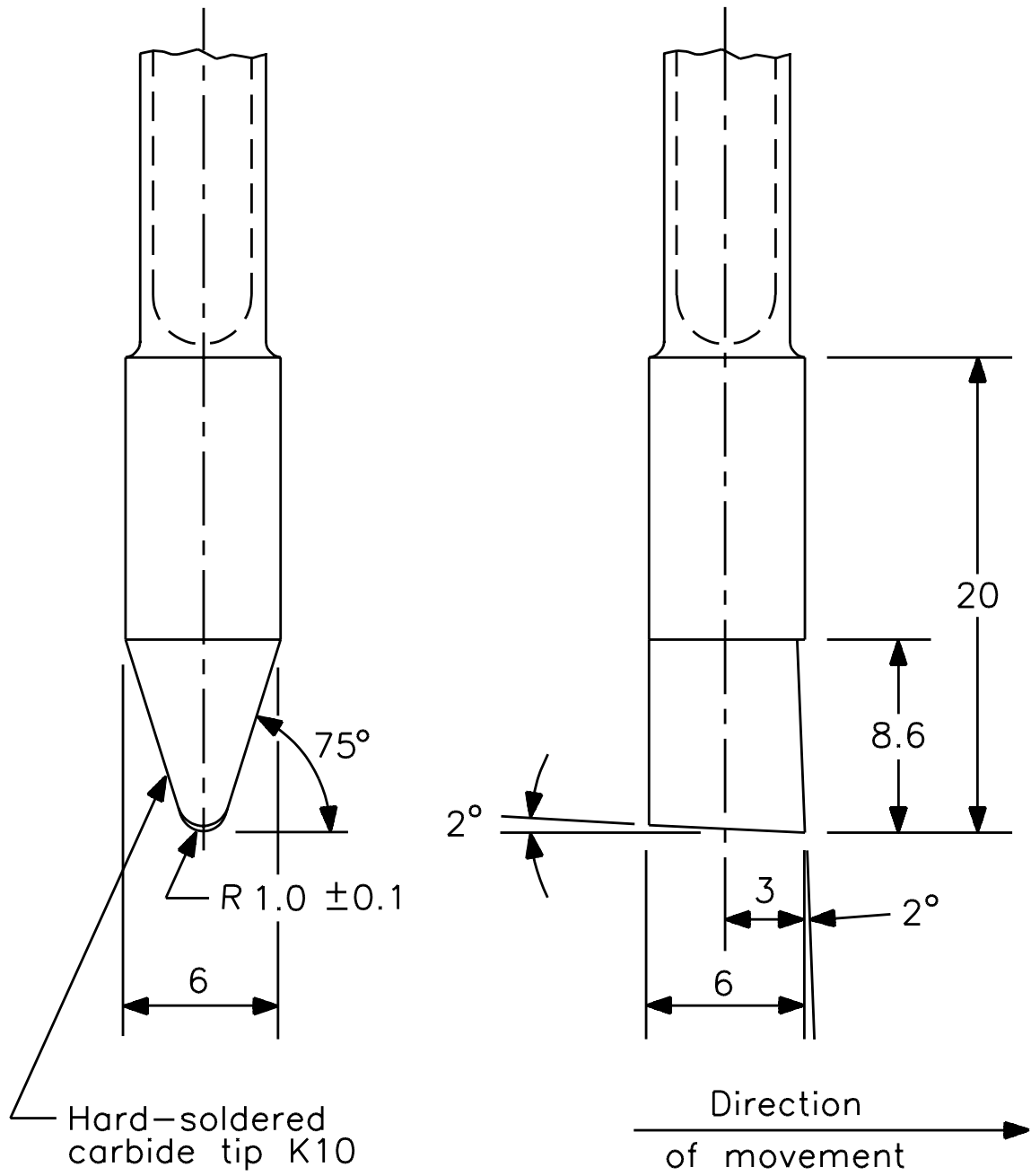

S3881

Dimensions in millimeters

SA5.4.2 The tool is applied using the following parameters:

- a) Force at right angles to the surface to be tested ..... 35 N ± 3N (8 lb ± 0.5 lb)
- b) Force parallel to the surface to be tested ..... Not exceeding 250 N (56 lb)
- c) The tool is to be drawn across the surface to be tested at a rate of 1 mm/s (0.04 in/s)

SA5.4.3 The test surface is to be scratched 3 times in a direction at right angles to the axis of the channel and 3 times in a direction parallel to the channel; the length of each scratch shall be 50 mm (2 in.).

SA5.4.4 The applicable part of the appliance shall then withstand the Strength Test of Section 8.24 the test pressure being reduced by 50%.

## SA6 MARKING AND INSTALLATION AND OPERATING INSTRUCTIONS

### SA6.1 Marking

SA6.1.1 The following markings, or the equivalent, shall be provided and shall be permanent when a flammable refrigerant is used:

- a) "DANGER – Risk Of Fire or Explosion. Flammable Refrigerant Used. Do Not Use Mechanical Devices To Defrost Refrigerator. Do Not Puncture Refrigerant Tubing".
- b) "DANGER – Risk Of Fire Or Explosion. Flammable Refrigerant Used. To Be Repaired Only By Trained Service Personnel. Do Not Puncture Refrigerant Tubing".
- c) "CAUTION – Risk Of Fire Or Explosion. Flammable Refrigerant Used. Consult Repair Manual/Owner's Guide Before Attempting To Service This Product. All Safety Precautions Must be Followed".
- d) "CAUTION – Risk Of Fire Or Explosion. Dispose Of Property In Accordance With Federal Or Local Regulations. Flammable Refrigerant Used".
- e) "CAUTION – Risk Of Fire Or Explosion Due To Puncture Of Refrigerant Tubing; Follow Handling Instructions Carefully. Flammable Refrigerant Used".

*Exception: Markings specified are not required for refrigerators and freezers using a refrigerant blend that complies with the exception to SA3.4.*

SA6.1.2 The marking described in item (a) of Clause SA6.1.1 shall be provided on or near any evaporators that can be contacted by the consumer. The markings described in items (b) and (c) of Clause SA6.1.1 shall be provided near the machine compartment. The marking described in item (d) of Clause SA6.1.1 shall be provided on the exterior of the refrigerator. The marking described in item (e) of Clause SA6.1.1 shall be provided near any and all exposed refrigerant tubing. The markings shall be in letters no less than 3.2 mm (1.8 inch) high.

SA6.1.3 The refrigeration system processing tubes shall be color coded to indicate the refrigerant used. The color coding shall be in accordance with Air Conditioning and Refrigeration Institute (ARI) Guideline N. The minimum color area shall be  $100\text{mm}^2(0.155\text{ in.}^2)$  and be clearly visible from the repair access area. Color coding may be waived if the process tube is located near the compressor and a label is affixed nearby indicating the refrigerant type.

SA6.1.4 The marking in item SA6.1.1 (b) shall also contain the symbol "Caution, risk of fire" (Fire in a triangle).



The color and format of this sign shall be as given in ISO 3864, symbol B.3.2. The perpendicular height of the triangle containing the "Caution, risk of the fire" sign shall be at least 15 mm (9/16 in).

## **SA6.2 Installation and operating instructions**

SA6.2.1 Installation and operating instructions shall be provided with cautionary statements concerning the handling, moving and use of the refrigerator or freezer to avoid either damaging the refrigerant tubing, or increasing the risk of a leak.

SA6.2.2 The shipping carton of a refrigerator or freezer that employs a flammable refrigerant shall be marked with proper handling instructions in compliance with the U.S. and Canadian government regulations. The warning marking described in item (e) of Clause SA6.1.1 shall also appear on the shipping carton.

SA6.2.3 The installation and operating instructions shall indicate that component parts shall be replaced with like components and that servicing shall be done by factory authorized service personnel, so as to minimize the risk of possible ignition due to incorrect parts or improper service.

## Appendix A

### Standards for Components

#### A1 Component Standards

A1.1 CSA and UL Standards listed below are used for evaluation of components and features of products covered by this Standard.

A1.2 Where reference is made to CSA Standards of the Canadian Electrical Code, Parts I and II, or to UL Standards, such reference shall be considered to refer to the latest edition and revision thereto, unless otherwise specified. This Standard refers to the following such Standards:

#### UL Standards

UL 1,  
*Flexible Metal Conduit;*

UL 4,  
*Armored Cable;*

UL 6,  
*Rigid Metal Conduit;*

UL 20,  
*General-Use Snap Switches;*

UL 44,  
*Rubber-Insulated Wires and Cables;*

UL 62,  
*Flexible Cord and Fixture Wire;*

UL 83,  
*Thermoplastic-Insulated Wires and Cables;*

UL 94,  
*Tests for Flammability of Plastic Materials for Parts in Devices and Appliances;*

UL 98,  
*Enclosed and Dead-Front Switches;*

UL 207,  
*Refrigerant-Containing Components and Accessories, Nonelectrical;*

UL 310,  
*Electrical Quick-Connect Terminals;*

UL 353,  
*Limit Controls;*

UL 429,  
*Electrically-Operated Valves;*

UL 458,  
*Power Converters and Power-Converter Systems for Recreational Vehicles;*

UL 486A,  
*Wire Connectors and Soldering Lugs for Use With Copper Conductors;*

UL 496,  
*Edison-Base Lampholders;*

UL 498,  
*Attachment Plugs and Receptacles;*

UL 506,  
*Specialty Transformers;*

UL 508,  
*Industrial Control Equipment;*

UL 512,  
*Fuseholders;*

UL 514A,  
*Metallic Outlet Boxes;*

UL 719,  
*Nonmetallic-Sheathed Cables;*

UL 746A,  
*Polymeric Materials - Short Term Property Evaluations;*

UL 746C,  
*Polymeric Materials - Use in Electrical Equipment Evaluations;*

UL 796,  
*Printed-Wiring Boards;*

UL 797,  
*Electrical Metallic Tubing;*

UL 810,  
*Capacitors;*

UL 817,  
*Cord Sets and Power-Supply Cords;*

UL 858,  
*Household Electric Ranges;*

UL 873,  
*Temperature-Indicating and -Regulating Equipment;*

UL 917,  
*Clock-Operated Switches;*



UL 969,  
*Marking and Labeling Systems;*

UL 984,  
*Hermetic Refrigerant Motor-Compressors;*

UL 1004,  
*Electric Motors;*

UL 1012,  
*Power Units Other Than Class 2;*

UL 1020,  
*Thermal Cutoffs for Use in Electrical Appliances and Components;*

UL 1054,  
*Special-Use Switches;*

UL 1059,  
*Terminal Blocks;*

UL 1097,  
*Double Insulation Systems for Use in Electrical Equipment;*

UL 1581,  
*Reference Standard for Electrical Wires, Cables, and Flexible Cords;*

UL 1585,  
*Class 2 and Class 3 Transformers.*

UL 2111,  
*Overheating Protection for Motors.*

### **CSA Standards**

C22.1-1990,  
*Canadian Electrical Code, Part I;*

CAN/CSA C22.2 No. 0-1982,  
*General Requirements - Canadian Electrical Code, Part II;*

C22.2 No. 0.1-M1985,  
*General Requirements for Double Insulated Equipment;*

C22.2 No. 0.3-92,  
*Test Methods for Electrical Wires and Cables;*

C22.2 No. 0.4-1982,  
*Bonding and Grounding of Electrical Equipment (Protective Grounding);*

C22.2 No. 0.5-1982,  
*Threaded Conduit Entries;*

C22.2 No. 0.15-M90,  
*Adhesive Labels;*

C22.2 No. 0.17-92,  
*Evaluation of Properties of Polymeric Materials;*

C22.2 No. 1-M90,  
*Radio, Television, and Electronic Apparatus;*

C22.2 No. 4-M89,  
*Enclosed Switches;*

C22.2 No. 8-M1986,  
*Electromagnetic Interference (EMI) Filters;*

C22.2 No. 13-1962(R1968),  
*Transformers for Luminous-Type Signs, Oil or Gas-Burner Ignition Equipment, Cold-Cathode Interior Lighting;*

C22.2 No. 14-M91,  
*Industrial Control Equipment;*

C22.2 No. 18-M1987,  
*Outlet Boxes, Conduit Boxes and Fittings;*

C22.2 No. 19-1935,  
*Construction and Test of Soldering Lugs;*

C22.2 No. 21-M90,  
*Cord Sets and Power-Supply Cords;*

C22.2 No. 24-1987,  
*Temperature-Indicating and -Regulating Equipment;*

C22.2 No. 38-M1986,  
*Thermoset Insulated Wires and Cables;*

C22.2 No. 39-M1987,  
*Fuseholder Assemblies;*

C22.2 No. 42-M1984,  
*General Use Receptacles, Attachment Plugs, and Similar Wiring Devices;*

C22.2 No. 43-M1984,  
*Lampholders;*

C22.2 No. 45-M1981,  
*Rigid Metal Conduit;*

C22.2 No. 48-M90,  
*Nonmetallic Sheathed Cable;*

C22.2 No. 51-M89,  
*Armoured Cable;*

C22.2 No. 55-M1986,  
*Special-Use Switches;*

C22.2 No. 56-1977,  
*Flexible Metal Conduit and Liquid-Tight Flexible Metal Conduit;*

C22.2 No. 61-M1985,  
*Household Electric Ranges;*

C22.2 No. 65-M1988,  
*Wire Connectors;*

C22.2 No. 66-1988,  
*Specialty Transformers;*

C22.2 No. 74-M92,  
*Equipment for Use With Electrical Discharge Lamp;*

C22.2 No. 75-M1983,  
*Thermoplastic-Insulated Wires and Cables;*

C22.2 No. 77-1988,  
*Motors with Inherent Overheating Protection;*

C22.2 No. 83-M1985,  
*Electrical Metallic Tubing;*

C22.2 No. 96-M92,  
*Portable Power Cables;*

C22.2 No. 100-M1985,  
*Motors and Generators;*

C22.2 No. 107.1-M91,  
*Commercial and Industrial Power Supplies;*

C22.2 No. 111-M1986,  
*General Use Switches;*

C22.2 No. 139-1982,  
*Electrically-Operated Valves;*

C22.2 No. 140.2-M91,  
*Hermetic Refrigerant Motor-Compressors;*

C22.2 No. 140.3-M1987,  
*Refrigerant-Containing Components for Use in Electrical Equipment;*

C22.2 No. 153-M1981,  
*Quick Connect Terminals;*

C22.2 No. 158-1987,  
*Terminal Blocks;*

C22.2 No. 177-1981,  
*Clock-Operated Switches;*

C22.2 No. 190-M1985,  
*Capacitors for Power Factor Correction;*

C22.2 No. 199-M89,  
*Combustion Safety Controls and Solid State Igniters for Gas- and Oil-Burning Equipment;*

C22.2 No. 209-M1985,  
*Thermal Cutoffs;*

C22.2 No. 223-M91,  
*Power Supplies with Extra-Low-Voltage Class Outputs;*

C22.2 No. 234-M90,  
*Safety of Component Power Supplies;*

Z240 RV Series-M86,  
*Recreational Vehicles.*

## **A2 Other Standards**

ANSI MC96.1-1982,  
*Temperature Measurement Thermocouples;*

ANSI Z21.1-1990,  
*Household Cooking Gas Appliances;*

ANSI Z21.57-1990,  
*Recreational Vehicle Cooking Gas Appliances;*

ANSI Z97.1-1984,  
*Safety Performance Specifications and Methods of Test for Glazing Materials Used in Buildings;*

ANSI/ASHRAE 15-1989,  
*Safety Code for Mechanical Refrigeration;*

ANSI/ASHRAE 34-1992,  
*Number Designation and Safety Classification of Refrigerants;*

ANSI/NEMA WD6-1988,  
*Wiring Devices – Dimensional Requirements;*

ANSI/NFPA No. 70-1993,  
*National Electrical Code;*

ANSI/SAE J513-1990,  
*Refrigeration Tube Fittings;*

ASME,  
*Unfired Pressure Vessel Code;*

ASTM E162-1990,  
*Standard Test Method for Surface Flammability of Materials Using A Radiant Heat Energy Source; BOCA,  
National Mechanical Code;*

*CAN3-C235-83, Preferred Voltage Levels for AC Systems, 0 to 50,000 V;*

*CAN/CGA-B149.1-M86, Natural Gas Installation Code;*

*CAN/CGA-B149.2-M86, Propane Installation Code;*

*CAN/ULC-S102-M88, Surface Burning Characteristics of Building Materials and Assemblies;*

CSA B52-92,  
*Mechanical Refrigeration Code;*

IEC 417,  
*Graphical Symbols for Use on Equipment;*

*The Standard Mechanical Code;*

*The Uniform Mechanical Code.*

#### **Abbreviations**

*ANSI - American National Standards Institute*

*ASHRAE - American Society of Heating, Refrigerating, Air-Conditioning Engineers*

*ASME - American Society of Mechanical Engineers*

*ASTM - American Society for Testing and Materials*

*BOCA - Building Officials and Code Administrators International*

*CFR - Code of Federal Regulations*

*CGA - Canadian Gas Association*

*IEC - International Electrotechnical Commission*

*NEMA - National Electrical Manufacturers Association*

*NFPA - National Fire Protection Association*

*SAE - Society of Automotive Engineers*

*ULC - Underwriters' Laboratories of Canada*

No Text on This Page

## Appendix B

### Marking Translations

This Appendix is provided for information only.

#### French Translation, Clause 11.1.4:

1. Si vous branchez cet appareil à un circuit protégé par des fusibles, utilisez un fusible à retardement.

#### French Translation, Clause 11.1.5:

2. ATTENTION: Pour réduire les risques d'incendie, utilisez un fusible de rechange de même type. Confier le remplacement à un technicien qualifié.

#### French Translation, Clause 11.1.9:

3. Installation non encastrée seulement.

#### French Translation, Clause 11.1.15:

4. ATTENTION: Pour empêcher qu'un enfant soit piégé, placez hors de la portée des enfants et loin du congélateur (ou du réfrigérateur).

#### French Translation, Clause 11.1.17:

5. ATTENTION: Utilisez des conducteurs en cuivre seulement.

#### French Translation, Clause 11.1.17:

6. ATTENTION: Utilisez des conducteurs en cuivre ou en aluminium.

#### French Translation, Clause 11.1.17:

7. ATTENTION: Utilisez des conducteurs en cuivre ou en aluminium avec recouvrement cuivré.

#### French Translation, Clause 11.1.17:

8. ATTENTION: Utilisez des conducteurs en cuivre, en aluminium avec recouvrement cuivré, ou en aluminium.

#### French Translation, Clause 11.1.18:

9. ATTENTION: N'UTILISEZ PAS DE PROLONGATEUR.

**French Translation, Clause 11.1.19:**

10. ATTENTION: Danger de choc électrique. Plus d'une source d'alimentation. Débranchez toutes les sources d'alimentation avant d'effectuer le service.

**French Translation, Clause 11.1.23:**

11. Remplacez par des ampoules 250 volts seulement.