

UL 291

ISBN 0-7629-0534-4

Automated Teller Systems

Underwriters Laboratories Inc. (UL)
333 Pfingsten Road
Northbrook, IL 60062-2096

UL Standard for Safety for Automated Teller Systems, UL 291

Fifth Edition, Dated May 28, 2001

UL is in the process of converting its Standards for Safety to the Standard Generalized Markup Language (SGML), and implementing an SGML compliant document management and publishing system. SGML - an international standard (ISO 8879-1986) - is a descriptive markup language that describes a document's structure and purpose, rather than its physical appearance on a page. Significant benefits that will result from UL's use of SGML and these new systems include increased productivity, reduced turnaround times, and data and information consistency, reusability, shareability, and portability. However, the fonts, pagination, and general formatting of UL's new electronic publishing system differ from that of UL's previous publishing system. Consequently, when revision pages are issued for a Standard with the new publishing system, these differences may result in the printing of pages on which no requirements have been changed - these additional pages result from relocation of text due to repagination and reformatting of the Standard with the new publishing system.

The master for this Standard at UL's Northbrook Office is the official document insofar as it relates to a UL service and the compliance of a product with respect to the requirements for that product and service, or if there are questions regarding the accuracy of this Standard.

UL's Standards for Safety are copyrighted by UL. Neither a printed copy of a Standard, nor the distribution diskette for a Standard-on-Diskette and the file for the Standard on the distribution diskette should be altered in any way. All of UL's Standards and all copyrights, ownerships, and rights regarding those Standards shall remain the sole and exclusive property of UL.

All rights reserved. No part of this publication may be reproduced, stored in a retrieval system, or transmitted in any form by any means, electronic, mechanical photocopying, recording, or otherwise without prior permission of UL.

Revisions of UL Standards for Safety are issued from time to time. A UL Standard for Safety is current only if it incorporates the most recently adopted revisions.

UL provides this Standard "as is" without warranty of any kind, either expressed or implied, including but not limited to, the implied warranties of merchantability or fitness for any purpose.

In no event will UL be liable for any special, incidental, consequential, indirect or similar damages, including loss of profits, lost savings, loss of data, or any other damages arising out of the use of or the inability to use this Standard, even if UL or an authorized UL representative has been advised of the possibility of such damage. In no event shall UL's liability for any damage ever exceed the price paid for this Standard, regardless of the form of the claim.

UL will attempt to answer support requests concerning electronic versions of its Standards. However, this support service is offered on a reasonable efforts basis only, and UL may not be able to resolve every support request. UL supports the electronic versions of its Standards only if they are used under the conditions and operating systems for which it is intended. UL's support policies may change from time-to-time without notification.

UL reserves the right to change the format, presentation, file types and formats, delivery methods and formats, and the like of both its printed and electronic Standards without prior notice.

Purchasers of the electronic versions of UL's Standards for Safety agree to defend, indemnify, and hold UL harmless from and against any loss, expense, liability, damage, claim, or judgement (including reasonable attorney's fees) resulting from any error or deviation introduced while purchaser is storing an electronic Standard on the purchaser's computer system.

If a single-user version electronic Standard was purchased, one copy of this Standard may be stored on the hard disk of a single personal computer, or on a single LAN file-server or the permanent storage device of a multiple-user computer in such a manner that this Standard may only be accessed by one user at a time and for which there is no possibility of multiple concurrent access.

If a multiple-user version electronic Standard was purchased, one copy of the Standard may be stored on a single LAN file-server, or on the permanent storage device of a multiple-user computer, or on an Intranet server. The number of concurrent users shall not exceed the number of users authorized.

Electronic Standards are intended for on-line use, such as for viewing the requirements of a Standard, conducting a word search, and the like. Only one copy of the Standard may be printed from each single-user version of an electronic Standard. Only one copy of the Standard may be printed for each authorized user of a multiple-user version of an electronic Standard. Because of differences in the computer/software/printer setup used by UL and those of electronic Standards purchasers, the printed copy obtained by a purchaser may not look exactly like the on-line screen view or the printed Standard.

An employee of an organization purchasing a UL Standard can make a copy of the page or pages being viewed for their own fair and/or practical internal use.

The requirements in this Standard are now in effect, except for those paragraphs, sections, tables, figures, and/or other elements of the Standard having future effective dates as indicated in the note following the affected item. The prior text for requirements that have been revised and that have a future effective date are located after the Standard, and are preceded by a "SUPERSEDED REQUIREMENTS" notice.

New product submittals made prior to a specified future effective date will be judged under all of the requirements in this Standard including those requirements with a specified future effective date, unless the applicant specifically requests that the product be judged under the current requirements. However, if the applicant elects this option, it should be noted that compliance with all the requirements in this Standard will be required as a condition of continued Listing, Recognition and Follow-Up Services after the effective date, and understanding of this should be signified in writing.

Copyright © 2001 Underwriters Laboratories Inc.

This Standard consists of pages dated as shown in the following checklist:

Page	Date
1-68.....	May 28, 2001
A1-A2.....	May 28, 2001

May 28, 2001

1

UL 291

Standard for Automated Teller Systems

First Edition – October, 1976
Second Edition – November, 1977
Third Edition – July, 1987
Fourth Edition – August, 1995

Fifth Edition

May 28, 2001

An effective date included as a note immediately following certain requirements is one established by Underwriters Laboratories Inc.

Revisions of this Standard will be made by issuing revised or additional pages bearing their date of issue. A UL Standard is current only if it incorporates the most recently adopted revisions, all of which are itemized on the transmittal notice that accompanies the latest set of revised requirements.

ISBN 0-7629-0534-4

COPYRIGHT © 1986, 2001 UNDERWRITERS LABORATORIES INC.

No Text on This Page

CONTENTS

FOREWORD	6
----------------	---

INTRODUCTION

1 Scope	7
2 General	7
2.1 Components	7
2.2 Units of measurement	8
2.3 Undated references	8
2.4 Terminology	8
3 Glossary	8
4 Installation and Operating Instructions	11

CONSTRUCTION

5 Enclosures	11
5.1 General	11
5.2 Openings	14
5.3 Cast metal	17
5.4 Sheet metal	18
5.5 Nonmetallic	20
5.6 Accessibility of live or hazardous parts	20
5.7 Interlocks and protective devices	24
5.8 Covers	24
6 Corrosion Protection	25
7 Field-Wiring Connections	25
7.1 General	25
7.2 Supply connections	25
7.3 Field-wiring terminals	26
7.4 Leads	27
7.5 Equipment grounding connection	28
7.6 Grounded supply conductor connection	29
7.7 Field-wiring compartments	29
7.8 Strain relief	29
8 Internal Wiring	30
8.1 General	30
8.2 Barriers	30
8.3 Wireways	31
8.4 Splices	31
8.5 Bushings	31
8.6 Strain relief	32
9 Bonding for Grounding	32
10 Electrical Components	33
10.1 Printed-wiring boards	33
10.2 Coil windings	33
10.3 Switches	33
10.4 Semiconductors	33
10.5 Lampholders and lamps	33
10.6 Protective devices	34
10.7 Current-carrying parts	34

10.8 Insulating material	34
10.9 Mounting of components	35
10.10 Motors	35
10.11 Overload protection	35
11 Spacings	36
12 Customer Access Panel	38
13 Security Container	38
13.1 General	38
13.2 24-hour service – level 1	40
13.3 24-hour service – level 2	40
13.4 Business hour service	40
14 Protection of Service Personnel	41

PERFORMANCE

OVERALL PRODUCT

15 General	41
16 Normal Operation Test	42
17 Input Test	42
18 Voltage Variations Test	42
19 Jarring Test	43
20 Temperature Test	44
21 Overload Test	48
22 Endurance Test	48
23 Variable Ambient Temperature Test	49
24 Humidity Test	49
25 Leakage Current Test	49
26 Transient Test	51
27 Rain Test	52
28 Ignition Test	55
28.1 General	55
28.2 Hot flaming oil	55
29 Dielectric Withstand Test	56
30 Strain Relief Tests	57
30.1 Power supply cord	57
30.2 Field-wiring leads	57
30.3 Internal wiring	57
31 Flexure Test	57

RESISTANCE TO EXPERT ATTACK

32 Objective	57
33 Indicators	58
34 Test of Customer Access Panel – 24-Hour Service	58
34.1 General	58
34.2 Tools	58
34.3 Time	59
34.4 Methods	59
35 Test of Currency Security Container – 24-Hour Service	59
35.1 General	59
35.2 Tools – level 1	60
35.3 Tools – level 2	60

35.4	Time60
35.5	Methods61
36	Test of Business Hour Service Automated Teller System62
36.1	General62
36.2	Tools62
36.3	Attack62
36.4	Methods63
37	Record Protection63
38	Depository Tests64
38.1	General64
38.2	Depository container64
38.3	Depository mechanism64

MANUFACTURING AND PRODUCTION TESTS FOR HIGH-VOLTAGE PRODUCTS

39	Production-Line Dielectric Voltage Withstand Test64
40	Production-Line Grounding Continuity Test65

MARKING

41	General65
----	---------------	-----

ACCESSORY EQUIPMENT

42	General67
43	Construction67
44	Performance (Installation) Test68
45	Marking68

APPENDIX A

Standards for Components.....	A1
-------------------------------	----

FOREWORD

A. This Standard contains basic requirements for products covered by Underwriters Laboratories Inc. (UL) under its Follow-Up Service for this category within the limitations given below and in the Scope section of this Standard. These requirements are based upon sound engineering principles, research, records of tests and field experience, and an appreciation of the problems of manufacture, installation, and use derived from consultation with and information obtained from manufacturers, users, inspection authorities, and others having specialized experience. They are subject to revision as further experience and investigation may show is necessary or desirable.

B. The observance of the requirements of this Standard by a manufacturer is one of the conditions of the continued coverage of the manufacturer's product.

C. A product which complies with the text of this Standard will not necessarily be judged to comply with the Standard if, when examined and tested, it is found to have other features which impair the level of safety contemplated by these requirements.

D. A product employing materials or having forms of construction which conflict with specific requirements of the Standard cannot be judged to comply with the Standard. A product employing materials or having forms of construction not addressed by this Standard may be examined and tested according to the intent of the requirements and, if found to meet the intent of this Standard, may be judged to comply with the Standard.

E. UL, in performing its functions in accordance with its objectives, does not assume or undertake to discharge any responsibility of the manufacturer or any other party. The opinions and findings of UL represent its professional judgment given with due consideration to the necessary limitations of practical operation and state of the art at the time the Standard is processed. UL shall not be responsible to anyone for the use of or reliance upon this Standard by anyone. UL shall not incur any obligation or liability for damages, including consequential damages, arising out of or in connection with the use, interpretation of, or reliance upon this Standard.

F. Many tests required by the Standards of UL are inherently hazardous and adequate safeguards for personnel and property shall be employed in conducting such tests.

INTRODUCTION

1 Scope

1.1 These requirements cover the construction and security of equipment intended to automatically dispense currency when operated as intended by an authorized customer, and to provide a limited degree of protection against unauthorized removal of currency.

1.2 If the product also receives deposits, the same degree of protection shall also be provided for the deposits.

1.3 Records shall be made in order that the authorized customer may be debited for the currency dispensed. A limited degree of protection against unauthorized manipulation or removal of the records that will prevent proper debit shall be provided.

1.4 A teller's cash dispenser is not required to make records.

1.5 These requirements cover products intended for permanent connection to 600-volts or lower-potential branch circuits, and products intended for cord connection to 300-volt or lower-potential branch circuits. The branch circuits and the means of supplying the units from them are intended to comply with the National Electrical Code, ANSI/NFPA 70.

1.6 A product that contains features, characteristics, components, materials, or systems new or different from those covered by the requirements in this standard, and that involves a risk of fire or of electric shock or injury to persons shall be evaluated using appropriate additional component and end-product requirements to maintain the level of safety as originally anticipated by the intent of this standard. A product whose features, characteristics, components, materials, or systems conflict with specific requirements or provisions of this standard does not comply with this standard. Revision of requirements shall be proposed and adopted in conformance with the methods employed for development, revision, and implementation of this standard.

2 General

2.1 Components

2.1.1 Except as indicated in 2.1.2, a component of a product covered by this standard shall comply with the requirements for that component. See Appendix A for a list of standards covering components used in the products covered by this standard.

2.1.2 A component is not required to comply with a specific requirement that:

- a) Involves a feature or characteristic not required in the application of the component in the product covered by this standard, or
- b) Is superseded by a requirement in this standard.

2.1.3 A component shall be used in accordance with its rating established for the intended conditions of use.

2.1.4 Specific components are incomplete in construction features or restricted in performance capabilities. Such components are intended for use only under limited conditions, such as certain temperatures not exceeding specified limits, and shall be used only under those specific conditions.

2.2 Units of measurement

2.2.1 Values stated without parentheses are the requirement. Values in parentheses are explanatory or approximate information.

2.2.2 Unless otherwise indicated, all voltage and current values mentioned in this standard are root-mean-square (rms).

2.3 Undated references

2.3.1 Any undated reference to a code or standard appearing in the requirements of this standard shall be interpreted as referring to the latest edition of that code or standard.

2.4 Terminology

2.4.1 The term "product" as used in this standard refers to any equipment covered by this standard.

3 Glossary

3.1 For the purpose of this standard, the following definitions apply.

3.2 AUTHORIZED CUSTOMER – A person authorized to conduct transactions at an automated teller system.

3.3 AUTOMATED TELLER MACHINE (ATM) – An unattended machine that will dispense currency when operated as intended by an authorized customer and which will provide a limited degree of protection against unauthorized removal of currency. The product may also receive deposits.

3.4 BUSINESS HOUR SERVICE – A product that is available during business hours only, is under observation by responsible persons, and is emptied of all valuables at the close of business.

3.5 CIRCUITS, ELECTRICAL –

a) HIGH-VOLTAGE – A circuit involving a potential of not more than 600 volts and having circuit characteristics in excess of those of a low-voltage, power-limited circuit;

b) LOW-VOLTAGE (POWER-LIMITED) – A circuit involving a potential of not more than 30 volts alternating current (AC) rms, 42.4 volts direct current (DC) or AC peak, and providing not more than 100 volt-amperes (VA) rated output. The 100 VA limit shall be provided by the design of the transformer, a fixed impedance, a non-interchangeable fuse, a nonadjustable manual reset circuit protective device, or a reliable regulating network;

c) LINE-VOLTAGE – The voltage of any field-connected source of supply other than batteries, nominally 50 – 60 hertz (Hz); 115, 208, or 230 volts.

3.6 CUSTOMER ACCESS PANEL – That portion of an automated teller system that is made available to an authorized customer for the performance of transactions.

3.7 ENCLOSURE – The word enclosure refers only to parts that enclose electrical components, including uninsulated live parts involving a shock or energy hazard. It may be an integral part of a component, a separate item, part of the ultimate enclosure, or the ultimate enclosure (outer cabinet).

3.8 ENERGY, RISK OF RELEASE OF – A risk of fire or electric shock due to release of energy is considered to exist at any exposed live part of a piece of equipment if, between the exposed live part and an adjacent exposed live or dead metal part of different polarity, there exists a potential of 2 volts or more and either:

- a) An available continuous power level of 240 VA (or more) or
- b) A reactive energy level of 20 joules (or more).

3.9 FISHING – Introducing into the product any form of lines, wires, or similar items to which one or more hooks or other devices may be attached, that may be manipulated so as to grasp the currency or a deposit and then withdraw it.

3.10 FORCING – The use of pry bars, screwdrivers, wrenches, or similar tools, to enlarge an opening, or to create an opening by breaking out or distorting a part, to gain access to the currency, deposits or records.

3.11 FREESTANDING INSTALLATION – The installation of an automated teller machine that is not through a building wall, a counter structure, or within a kiosk or similar structure that restricts the physical removal of the unit by requiring the damage or destruction of the structure. The freestanding automated teller machine may be recessed into a wall, but is open on one or more sides.

3.12 LIVE PARTS – Denotes metal or other conductive parts that, in normal use, have a potential difference with respect to ground or any other conductive part.

3.13 MAXIMUM NORMAL LOAD – In testing a product, maximum normal load is considered to be the load that approximates as closely as possible the most severe conditions of normal use. It is not a deliberate overload except as the conditions of actual use can be more severe than the maximum load conditions that are recommended by the manufacturer of the product.

3.14 OPERATOR PERSONNEL – Persons authorized to perform the functions defined in 3.15.

3.15 OPERATOR SERVICING – Any form of servicing that might be performed by personnel other than those who are trained to maintain the particular product. Changing ribbons is considered to be a serviceman's function rather than operator servicing if the act involves extensive disassembly of the machine. Some examples of operator servicing are as follows:

- a) The attachment of accessories by means of attachment-plug caps and receptacles or by means of other separable connectors;
- b) The changing of tapes or ribbons that do not involve complicated operations;
- c) The replacement of recording tapes, discs, program boards, punched cards, or paper forms;

- d) Resetting of circuit breakers, replacement of fuses, replacement of lamps that are accessible without the use of tools; and replacement of lamps likely to require frequent replacement, such as lamps of the projector type, whether or not the operation requires the use of tools;
- e) The making of routine operating adjustments necessary to adapt the product for its different intended functions;
- f) Routine cleaning, or removal of jams of data-handling media, currency, deposits and records; and
- g) The loading and removal of currency, removal of deposits, or removal of items retained by the product.

3.16 **PRODUCT** – A product is a freestanding portion of a system to which an identification number is applied. It is supported by a frame or frames and is self-enclosed or designed to be attached to another device.

- a) **FIXED** – A fixed product is one that is fastened or otherwise secured to the building at a specific location;
- b) **STATIONARY** – A stationary product is one that is not easily moved from one place to another in its intended use;
- c) **PORTABLE** – A portable product is one that actually is moved or can easily be moved from one place to another in its intended use.

3.17 **REMOTE AND AUTOMATIC CONTROL** – A unit of a product is considered to be remotely controlled if it is out of sight of and removed from the user. A unit of a product is considered to be automatically controlled if:

- a) Energization of such as a motor, solenoid, or magnet will occur without manual intervention or
- b) During any single predetermined cycle of operation, automatic changing of the mechanical load can reduce the speed of a motor sufficiently to reestablish starting-winding connections to the branch circuit.

3.18 **SECURITY CONTAINER** – An enclosure used to provide physical security for the currency used for dispensing, deposits received, and components that can be operated by unauthorized persons to obtain currency without debiting to proper accounts. The security container is rated as follows:

- a) Business Hour Service,
- b) 24-Hour Service – Level 1, and
- c) 24-Hour Service – Level 2.

3.19 **SHOCK, RISK OF ELECTRIC** – A risk of electric shock is considered to exist at any exposed live part of a product or system if the available open-circuit potential is higher than 42.4 volts peak and the available current through a 1500-ohm resistance is more than 5 milliamperes.

3.20 TELLER'S CASH DISPENSER – A product that will dispense currency when properly operated by an authorized teller or other employee of the financial institution using the product. The currency may be dispensed directly to a customer or to the teller.

3.21 TRAPPING (CURRENCY DISPENSER) – The use of a device or materials which may be introduced into the product in such a manner as to avoid detection, by an authorized user, in order to prevent the dispensed currency from reaching the customer. The dispensed currency can then be withdrawn after the customer has left.

3.22 TRAPPING (DEPOSITS) – The use of a device or materials which may be introduced into the product in such a manner as to avoid detection, by an authorized user, in order to prevent the deposit from reaching its security container. The deposit can then be withdrawn after the customer has left.

3.23 TWENTY-FOUR HOUR SERVICE – A product that is available for use at any time during both business and non-business hours.

4 Installation and Operating Instructions

4.1 A copy or draft of the installation and operating instructions intended to accompany each product or component, or equivalent information, is to be used as a guide in the examination and test of the product or component.

4.2 The instructions shall include such directions and information as deemed by the manufacturer to be necessary for the proper and safe installation, maintenance, and operation of the product.

CONSTRUCTION

5 Enclosures

5.1 General

5.1.1 Additional requirements contained in Security Container, Section 13, apply to parts of the product enclosure where resistance to physical attack is involved.

5.1.2 The frame and enclosure of a product shall be sufficiently strong and rigid to resist total or partial collapse with attendant reduction of spacings, loosening or displacement of parts and development of other conditions which could impair operation of the product and increase the risk of fire, electric shock, or personal injury.

5.1.3 The mounting means of an enclosure shall be accessible without disassembly of any operating part of the product. Removal of a completely assembled panel to mount the enclosure is not considered to be disassembly of an operating part.

5.1.4 An enclosure containing other than power-limited circuits shall be constructed to minimize the possibility of emission of flame, molten metal, flaming or glowing particles, or flaming drops. See the Ignition Test, Section 28.

5.1.5 The requirement in 5.1.4 necessitates either a noncombustible bottom in accordance with 5.2.4, or a protective barrier as described in Figure 5.1 under all areas containing flammable materials.

Exception: Materials or assemblies classified as V-1, when tested in accordance with the Standard for Tests for Flammability of Plastic Materials for Parts in Devices and Appliances, UL 94, need not comply with this requirement.

Figure 5.1
Protective pan

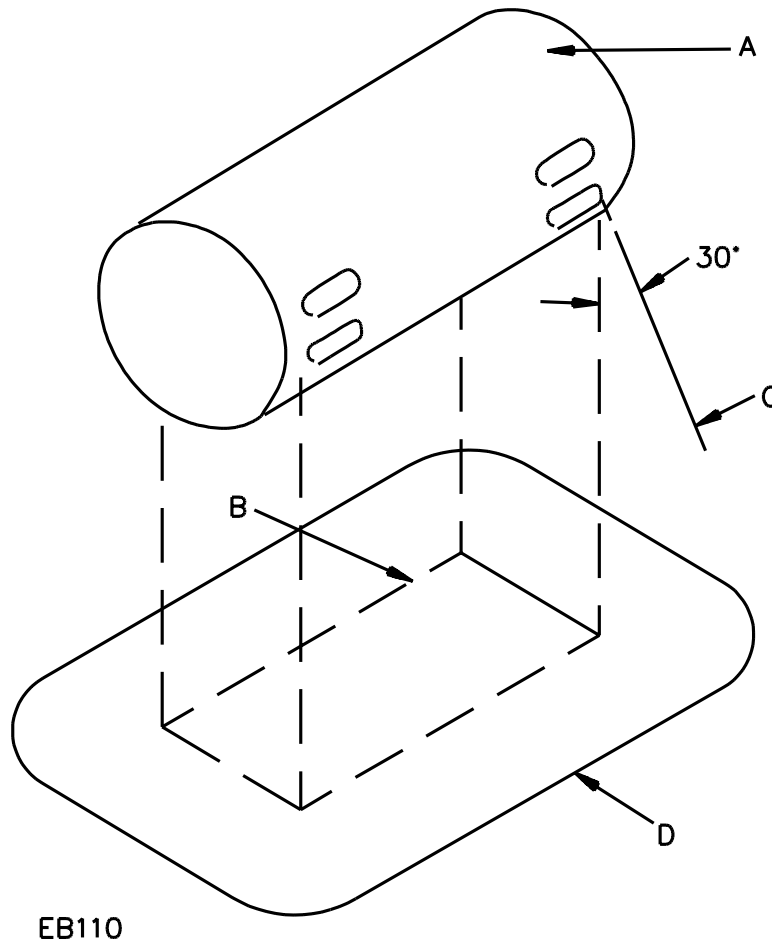

EB110

A – The entire component under which a barrier (flat or dished with or without a lip or other raised edge) of noncombustible material is to be provided. The figure above is of a metal enclosed component with ventilating openings to show that the protective barrier is required only for those openings from which flaming parts might come. If the component or assembly does not have its own noncombustible enclosure, the area to be protected would be the entire area occupied by the component or assembly.

B – Projection of the outline of the area of (A) which needs a bottom barrier vertically downward onto the horizontal plane of the lowest point on the outer edge (D) of the barrier.

C – Inclined line that traces out an area (D) on the horizontal plane of the barrier. Moving around the perimeter of the area (B) which needs a bottom barrier, this line projects at a 30-degree angle from the line extending vertically at every point around the perimeter of (A) and oriented to trace out the largest area, except that the angle may be less than 30 degrees if the barrier or portion of the bottom cover contacts a vertical barrier or side panel of noncombustible material, or if the horizontal extension of the barrier (B) to (D) would exceed 6 inches (150 mm).

D – Minimum outline of the barrier, except that the extension B–D need not exceed 6 inches (150 mm) (flat or dished with or without lip or other raised edge). The bottom of the barrier may be flat or formed in any manner provided that every point of area (D) is at or below the lowest point on the outer edge of the barrier.

5.1.6 A construction using individual barriers under components, groups of components or assemblies, as specified in Figure 5.1, is to be considered as complying with the requirement in 5.1.4.

5.2 Openings

5.2.1 Openings in the top of the enclosure of desk mounted products and in the top of the enclosure of floor mounted products more than 48 inches (1.2 m) in height shall be so located and of such size as to prevent entry of foreign objects. Openings directly over uninsulated live parts shall not exceed 0.187 inch (4.75 mm) in any dimension unless the configuration of the openings prevents direct entry to such parts. See Figure 5.2 for examples of acceptable top cover designs.

Figure 5.2
Cross sections of top cover designs

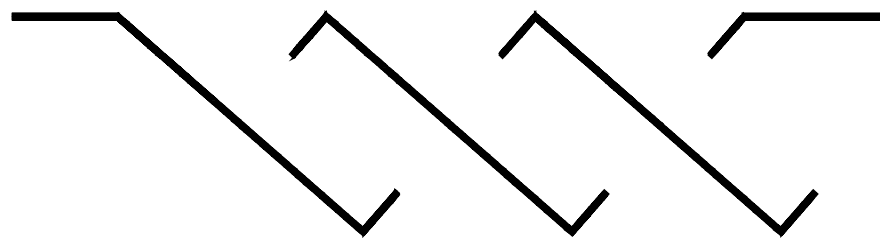

SLANTED OPENINGS

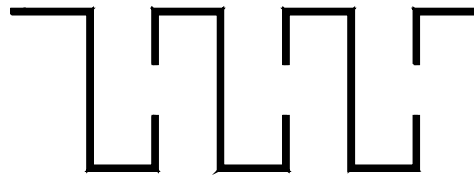

EC500

VERTICAL OPENINGS

5.2.2 There shall not be openings directly over uninsulated live parts involving risk of electric shock and release of energy in the top of the enclosure of a floor mounted unit 48 inches (1.2 m) or less in height.

5.2.3 Openings in the sides of the enclosure shall be so located and of such size as to prevent entry of a foreign object and to prevent personnel contact with internal parts. See also 5.6.1 – 5.6.12. Louvers may be used if shaped to deflect external falling objects outward. See Figure 5.3 for examples of louver designs.

Figure 5.3
Louvers

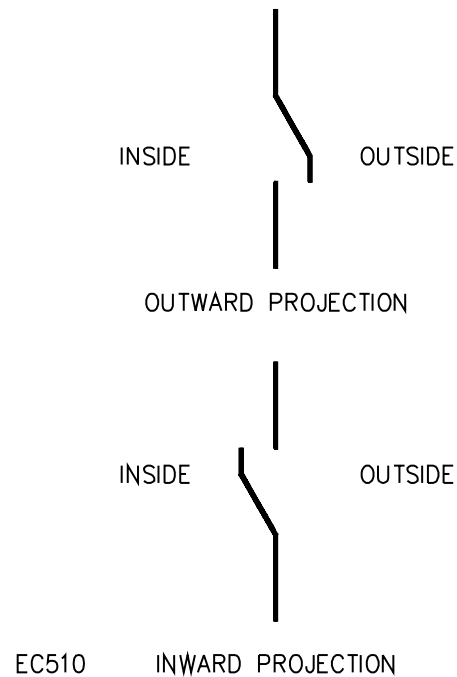

5.2.4 Ventilating openings may be provided in the bottom panels or protective pans under areas containing materials not classified at least V-1 (see 5.1.5), if constructed in a manner that prevents materials from falling directly from the interior of the product onto the supporting surface or into an air-handling area or any other location under the product. Figure 5.4 illustrates a type of baffle that meets this requirement. A second type of construction which may be used is a 0.040-inch (1.02-mm) sheet-steel bottom panel in which 5/64-inch (2.0-mm) maximum round holes are spaced no closer than 1/8 inch (3.2 mm) center-to-center. Other constructions may be used provided they comply with the requirements of the Ignition Test, Section 28.

Figure 5.4
Baffle

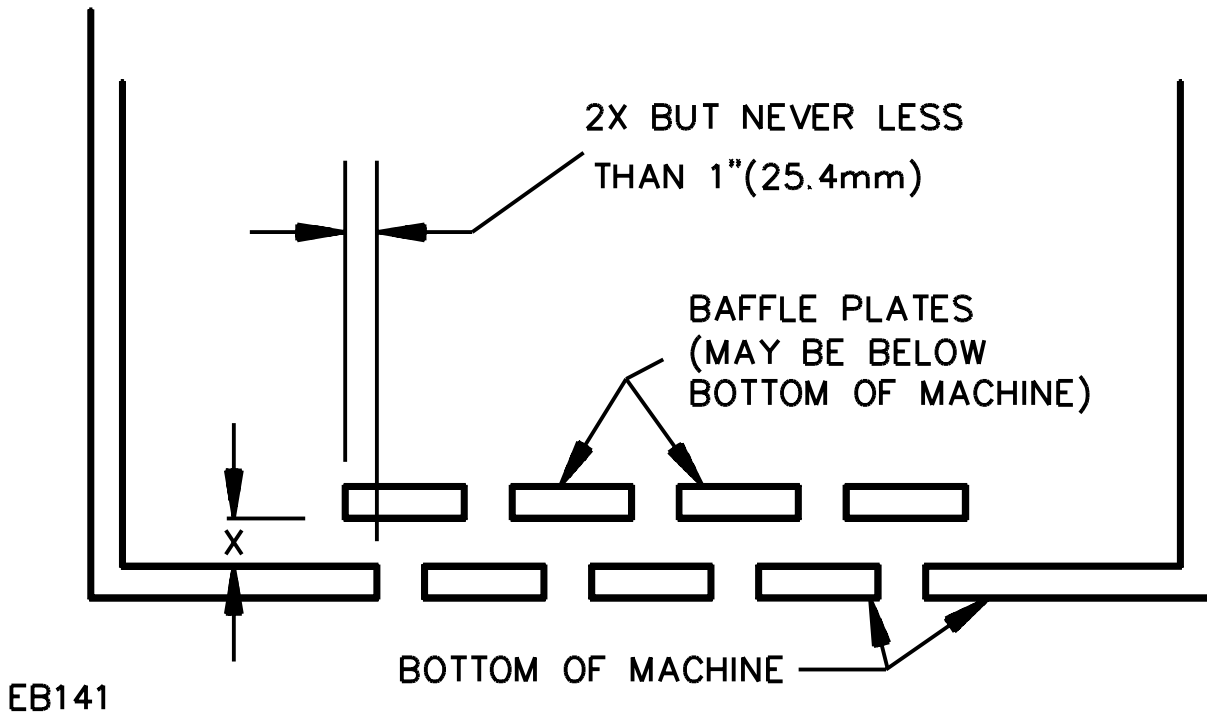

EB141

5.2.5 The bottom of the enclosure under areas containing only materials classified as at least V-1 (see 5.1.5) may have openings not larger than $1/16$ inch² (40.3 mm²).

5.2.6 Openings may be used without limitation of the size or number of openings in areas:

- a) Containing PVC, TFE, CTFE, FEP, or neoprene insulated wire cable;
- b) Containing plugs and receptacles; and
- c) Under impedance protected or thermally protected motors.

5.2.7 Openings in the enclosure shall not give access to any relays, terminals, controls, or related components that might be subject to tampering by hand or with tools smaller in diameter than the probe shown in Figure 5.5 that will affect the security of the product.

Figure 5.5
Probe for hand-held units and hand-held portions of units

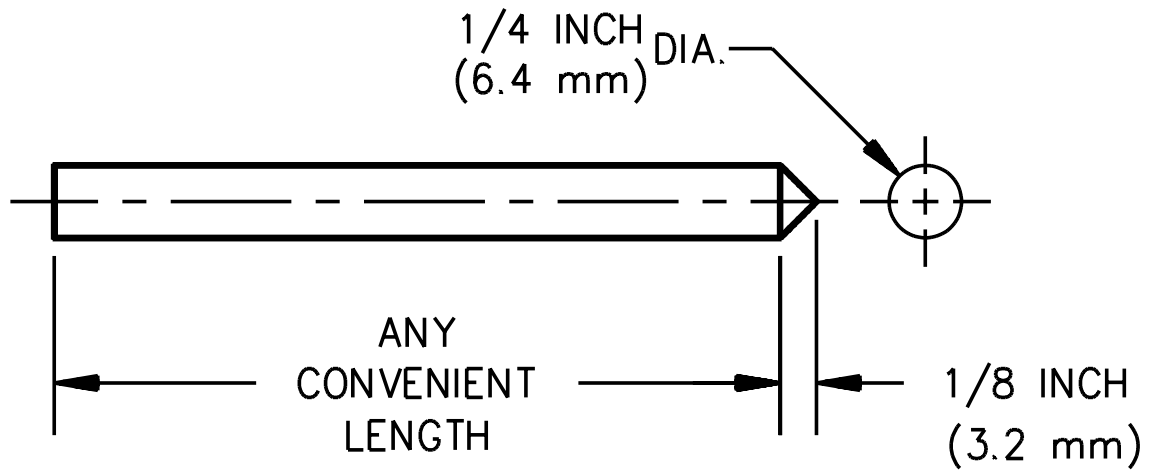

PA190

5.3 Cast metal

5.3.1 The thickness of cast metal for an enclosure shall be as indicated in Table 5.1.

Table 5.1
Cast-metal enclosures

Use, or dimensions of area involved ^a	Minimum thickness			
	Die-cast metal,		Cast metal of other	
	inch	(mm)	inch	(mm)
Area of 24 square inches (155 cm ²) or less having no dimension greater than 6 inches (152 mm)	1/16	1.6	1/8	3.2
Area greater than 24 square inches (155 cm ²) or having any dimension greater than 6 inches (152 mm)	3/32	2.4	1/8	3.2
At a threaded conduit hole	1/4	6.4	1/4	6.4
At an unthreaded conduit hole	1/8	3.2	1/8	3.2

^a The area limitation for metal 1/16 inch (1.6 mm) in thickness may be obtained by the provision of reinforcing ribs subdividing a larger area.

5.4 Sheet metal

5.4.1 The thickness of sheet metal used for the enclosure of a product shall not be less than that indicated in Table 5.2 or 5.3, whichever applies.

Table 5.2
Minimum thickness of sheet metal for electrical enclosures
carbon steel or stainless steel

Without supporting frame ^a		With supporting frame or equivalent reinforcing ^a		Minimum thickness			
Maximum width, ^b		Maximum length, ^c		Uncoated,		Metal coated,	
inches	(cm)	inches	(cm)	inch	(mm)	inch	(mm)
				[MSG]		[GSG]	
4.0	(10.2)	Not limited	6.25 (15.9)	Not limited	0.020 (0.51)	0.023 (0.58)	
4.75	(12.1)	5.75 (14.6)	6.75 (17.1)	8.25 (21.0)	[24]	[24]	
6.0	(15.2)	Not limited	9.5 (24.1)	Not limited	0.026 (0.66)	0.029 (0.74)	
7.0	(17.8)	8.75 (22.2)	10.0 (25.4)	12.5 (31.8)	[22]	[22]	
8.0	(20.3)	Not limited	12.0 (30.5)	Not limited	0.032 (0.81)	0.034 (0.86)	
9.0	(22.9)	11.5 (29.2)	13.0 (33.0)	16.0 (40.6)	[20]	[20]	
12.5	(31.8)	Not limited	19.5 (49.5)	Not limited	0.042 (1.07)	0.045 (1.14)	
14.0	(35.6)	18.0 (45.7)	21.0 (53.3)	25.0 (63.5)	[18]	[18]	
18.0	(45.7)	Not limited	27.0 (68.6)	Not limited	0.053 (1.35)	0.056 (1.42)	
20.0	(50.8)	25.0 (63.5)	29.0 (73.7)	36.0 (91.4)	[16]	[16]	
22.0	(55.9)	Not limited	33.0 (83.8)	Not limited	0.060 (1.52)	0.063 (1.60)	
25.0	(63.5)	31.0 (78.7)	35.0 (88.9)	43.0 (109.2)	[15]	[15]	
25.0	(63.5)	Not limited	39.0 (99.1)	Not limited	0.067 (1.70)	0.070 (1.78)	
29.0	(73.7)	36.0 (91.4)	41.0 (104.1)	51.0 (129.5)	[14]	[14]	
33.0	(83.8)	Not limited	51.0 (129.5)	Not limited	0.080 (2.03)	0.084 (2.13)	
38.0	(96.5)	47.0 (119.4)	54.0 (137.2)	66.0 (167.6)	[13]	[13]	
42.0	(106.7)	Not limited	64.0 (162.6)	Not limited	0.093 (2.36)	0.097 (2.46)	
47.0	(119.4)	59.0 (149.9)	68.0 (172.7)	84.0 (213.4)	[12]	[12]	
52.0	(132.1)	Not limited	80.0 (203.2)	Not limited	0.108 (2.74)	0.111 (2.82)	
60.0	(152.4)	74.0 (188.0)	84.0 (213.4)	103.0 (261.6)	[11]	[11]	
63.0	(160.0)	Not limited	97.0 (246.4)	Not limited	0.123 (3.12)	0.126 (3.20)	
73.0	(185.4)	90.0 (228.6)	103.0 (261.6)	127.0 (322.6)	[10]	[10]	

^a A supporting frame is a structure of angle or channel or a folded rigid section of sheet metal which is rigidly attached to and has essentially the same outside dimensions as the enclosure surface and which has sufficient torsional rigidity to resist the bending moments which may be applied via the enclosure surface when it is deflected. Construction that is considered to have equivalent reinforcing may be accomplished by designs that will produce a structure that is as rigid as one built with a frame of angles or channels. Construction considered to be without supporting frame includes:

- 1) A single sheet with single formed flanges (formed edges),
- 2) A single sheet which is corrugated or ribbed, and
- 3) An enclosure surface loosely attached to a frame, for example, with spring clips.

^b The width is the smaller dimension of a rectangular sheet metal piece which is part of an enclosure. Adjacent surfaces of an enclosure may have supports in common and be made of a single sheet.

^c For panels which are not supported along one side, for example, side panels of boxes, the length of the unsupported side shall be limited to the dimensions specified unless the side in question is provided with a flange at least 1/2 inch (12.7 mm) wide.

Table 5.3
Minimum thickness of sheet metal for electrical enclosures
aluminum, copper, or brass

Without supporting frame ^a		With supporting frame or equivalent reinforcing ^a				Minimum thickness, inch (mm)	
Maximum width, ^b inches (cm)	Maximum length, ^c inches (cm)	Maximum width, ^b inches (cm)	Maximum length, inches (cm)	Maximum width, ^b inches (cm)	Maximum length, inches (cm)		
3.0 3.5	7.6 8.9	Not limited 4.0 10.2	7.0 17.8 8.5 21.6	Not limited 9.5 24.1	Not limited 9.5 24.1	0.023 0.58	0.58
4.0 5.0	10.2 12.7	Not limited 6.0 15.2	10.0 25.4 10.5 26.7	Not limited 13.5 34.3	Not limited 13.5 34.3	0.029 0.74	0.74
6.0 6.5	15.2 16.5	Not limited 8.0 20.3	14.0 35.6 15.0 38.1	Not limited 18.0 45.7	Not limited 18.0 45.7	0.036 0.91	0.91
8.0 9.5	20.3 24.1	Not limited 11.5 29.2	19.0 48.3 21.0 53.3	Not limited 25.0 63.5	Not limited 25.0 63.5	0.045 1.14	1.14
12.0 14.0	30.5 35.6	Not limited 16.0 40.6	28.0 71.1 30.0 76.2	Not limited 37.0 94.0	Not limited 37.0 94.0	0.058 1.47	1.47
18.0 20.0	45.7 50.8	Not limited 25.0 63.4	42.0 106.7 45.0 114.3	Not limited 55.0 139.7	Not limited 55.0 139.7	0.075 1.91	1.91
25.0 29.0	63.5 73.7	Not limited 36.0 91.4	60.0 152.4 64.0 162.6	Not limited 78.0 198.1	Not limited 78.0 198.1	0.095 2.41	2.41
37.0 42.0	94.0 106.7	Not limited 53.0 134.6	87.0 221.0 93.0 236.2	Not limited 114.0 289.6	Not limited 114.0 289.6	0.122 3.10	3.10
52.0 60.0	132.1 152.4	Not limited 74.0 188.0	123.0 312.4 130.0 330.2	Not limited 160.0 406.4	Not limited 160.0 406.4	0.153 3.89	3.89

^a A supporting frame is a structure of angle or channel or a folded rigid section of sheet metal which is rigidly attached to and has essentially the same outside dimensions as the enclosure surface and which has sufficient torsional rigidity to resist the bending moments which may be applied via the enclosure surface when it is deflected. Construction that is considered to have equivalent reinforcing may be accomplished by designs that will produce a structure which is as rigid as one built with a frame of angles or channels. Construction considered to be without supporting frame includes:

- 1) A single sheet with single formed flanges (formed edges),
- 2) A single sheet which is corrugated or ribbed, and
- 3) An enclosure surface loosely attached to a frame, for example, with spring clips.

^b The width is the smaller dimension of a rectangular sheet metal piece which is part of an enclosure. Adjacent surfaces of an enclosure may have supports in common and be made of a single sheet.

^c For panels which are not supported along one side, for example, side panels of boxes, the length of the unsupported side shall be limited to the dimensions specified unless the side in question is provided with a flange at least 1/2 inch (12.7 mm) wide.

5.4.2 A sheet metal member to which a wiring system is to be connected in the field shall have a thickness of not less than 0.032 inch (0.81 mm) if of uncoated steel, of not less than 0.034 inch (0.86 mm) if of galvanized steel, and of not less than 0.045 inch (1.14 mm) if of nonferrous metal.

5.5 Nonmetallic

5.5.1 If nonmetallic material is used for an enclosure, it shall be judged in accordance with 5.5.2 and shall have a wall thickness of not less than 1/16 inch (1.6 mm).

5.5.2 Among the factors taken into consideration when evaluating the acceptability of a nonmetallic enclosure are:

- a) The mechanical strength;
- b) Resistance to impact;
- c) Moisture-absorptive properties;
- d) Flammability and resistance to ignition from electrical sources;
- e) Dielectric strength, insulation resistance, and resistance to arc tracking; and
- f) Resistance to distortion and creeping at temperatures to which the material may be subjected.

All these factors are considered with respect to aging.

5.6 Accessibility of live or hazardous parts

5.6.1 The uninsulated live parts and hazardous parts of a product shall be so located or enclosed that protection is provided against the risk of fire, electric shock or accident from unintentional contact with them. Insulated brush caps do not require an additional enclosure.

5.6.2 Devices using glass envelopes, such as electron tubes, glass-enclosed relays, and similar parts, shall be enclosed or protected against mechanical damage.

5.6.3 Fan blades, blower wheels, pulleys, belts, and similar parts shall be so enclosed or guarded as to reduce the likelihood of injury to persons.

5.6.4 An interlocking mechanism which operates to disconnect power to a motor when a cover or panel is removed or opened for access to moving parts is considered to provide compliance with 5.6.3.

5.6.5 The degree of protection required in 5.6.3 depends upon the general design and the intended use of the product. The location where the product ordinarily will be used is considered when judging the acceptable degree of exposure of mechanical parts. Other factors taken into consideration in evaluating the acceptability of exposed moving parts are the:

- a) Degree of exposure;
- b) Sharpness of the moving parts;
- c) Risk of accidental contact with the moving parts;
- d) Speed of movement of those parts; and
- e) Risk of fingers, arms, or clothing being drawn into the moving parts such as at points where belts travel onto a pulley or where moving parts close in a pinching or shearing action.

5.6.6 Where the starting or restarting of a motor driving a moving part such as described in 5.6.3 is provided by an automatic cycling device such as an overcurrent device or thermal protector, the requirement of 5.6.3 will require the use of a guard if the part is exposed when making operating adjustments or changing replaceable parts or if the part is accessible without requiring the use of tools.

5.6.7 With reference to 5.6.6, the scroll of a centrifugal blower may be used as a guard for the blower wheel.

5.6.8 If any part of the external enclosure of a product must be removed for operator servicing, that part shall be removed before the product is examined in connection with the requirement in 5.6.1.

5.6.9 The following parts may be used for securing doors, covers, and panels that are not opened or removed for operator servicing if supplementary guards or similar parts are provided as described in 14.1 – 14.3:

- a) Thumbscrews;
- b) Finger latches;
- c) Screwdriver-, wrench-, and coin-operated latches;
- d) Magnetic and spring latches that cannot be accidentally bumped open; and
- e) Similar parts that result in reliable holding of a door or cover or support of a panel.

5.6.10 Panels as described in 5.6.9 are not to be opened or removed for the application of the probes mentioned in 5.6.4 and 5.6.5 in connection with the investigation of the accessibility of live or hazardous parts. See also 5.6.7.

5.6.11 In the enclosure of a unit an opening that does not permit entrance of 3/4-inch (19.1-mm) diameter rod may be used if a probe as illustrated in:

- a) Figure 5.6 cannot be made to touch any uninsulated live part or hazardous moving part while inserted through the opening and
- b) Figure 5.7 cannot be made to touch film-coated wire while inserted through the opening.

An opening that permits entrance of a 3/4-inch diameter rod may be used under the conditions described in 5.6.6. See Figure 5.8.

Figure 5.6
Probe for uninsulated live parts

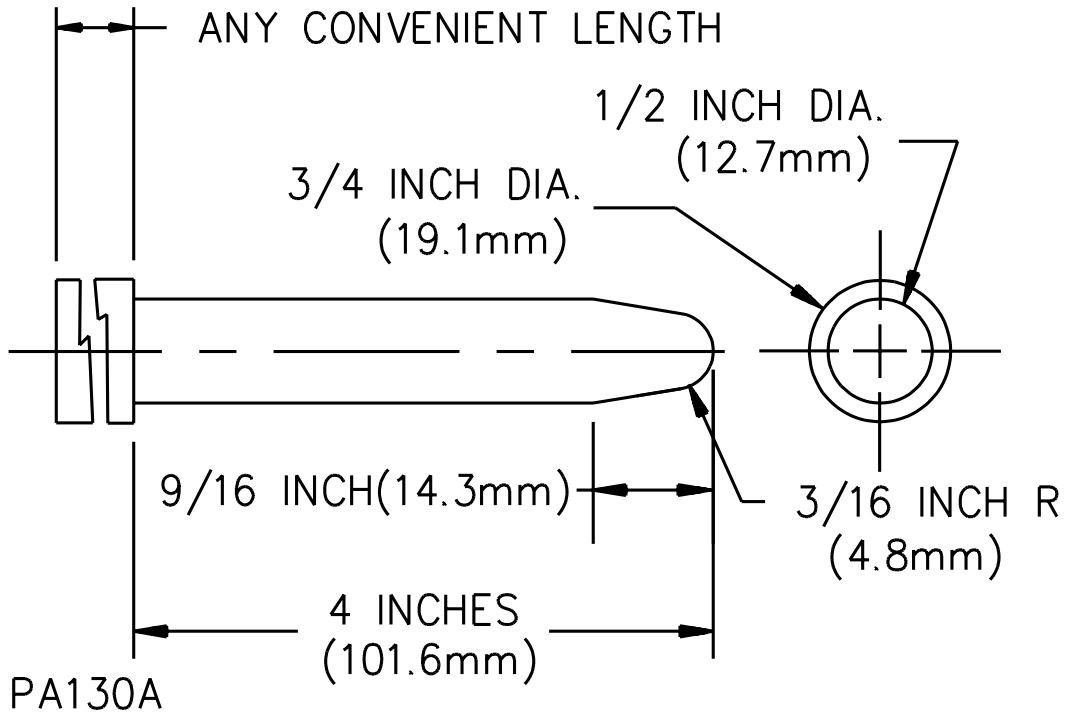

Figure 5.7
Probe for film-coated wire

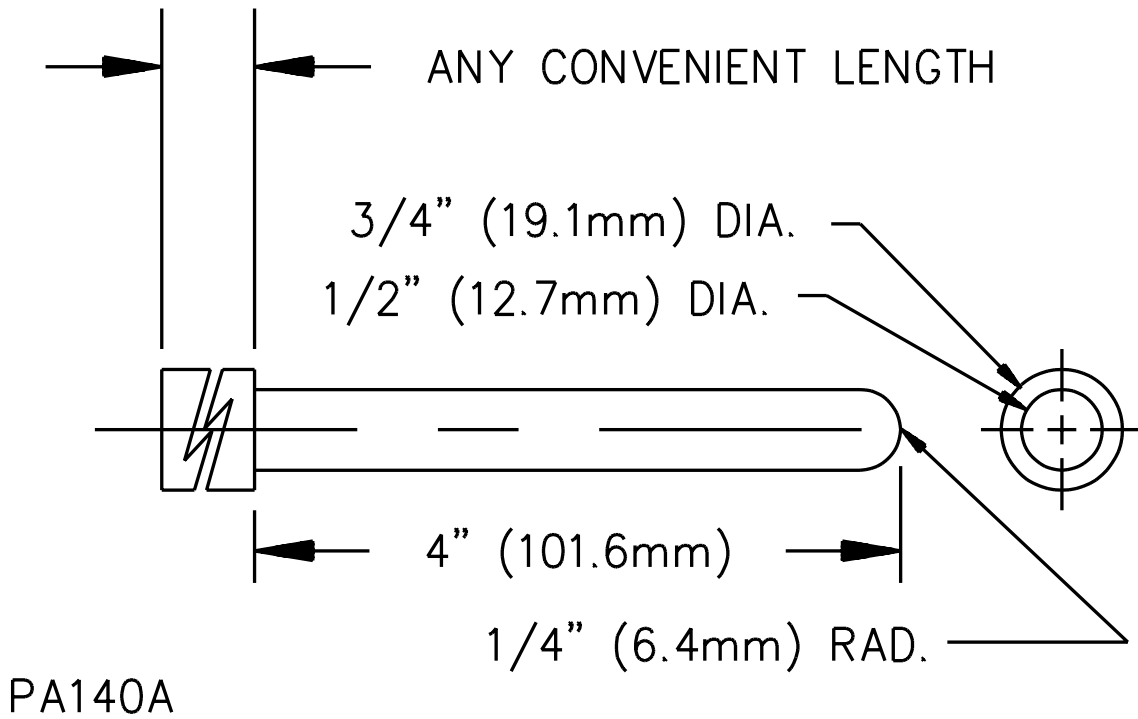
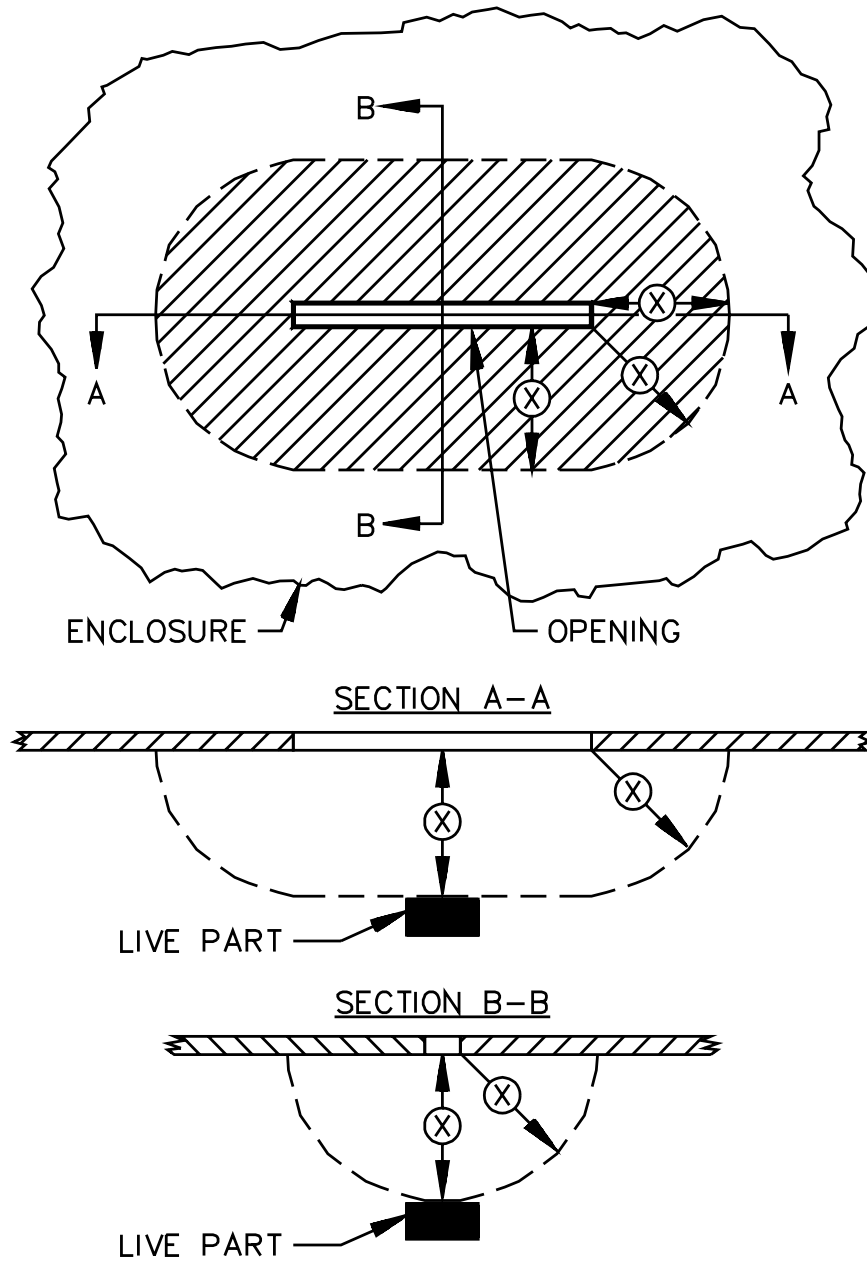

Figure 5.8
Opening in enclosure



EC100A

The opening may be used if, within the enclosure, there is no uninsulated live part or film-coated wire less than X inches (mm) from the perimeter of the opening, as well as within the volume generated by projecting the perimeter X inches (mm) normal to its plane. X equals five times the diameter of the largest diameter rod which can be inserted through the opening, but not less than 4 inches (102 mm).

5.6.12 The opening illustrated in Figure 5.8 may be used if, within the enclosure, there is no uninsulated live part or film-coated wire:

- a) Less than "X" inches from the perimeter of the opening, as well as
- b) Within the volume generated by projecting the perimeter "X" inches normal to its plane.

"X" equals five times the diameter of the largest-diameter rod that can be inserted through the opening, but is not less than 4 inches (102 mm). In evaluating an opening, any barrier located within the volume is to be ignored unless it intersects the boundaries of the volume in a continuous closed line.

5.7 Interlocks and protective devices

5.7.1 An interlock provided for the purpose of protecting an operator or serviceman against injury or electric shock shall be of a type or in such a location that it requires an intentional operation to bypass.

5.7.2 The bypass means shall be such that the interlock is self-restoring as the unit is returned to its intended operation.

5.7.3 A protective device provided to remove a stored-energy charge from an internal circuit shall operate automatically when the circuit is de-energized.

5.8 Covers

5.8.1 An enclosure cover shall be hinged, sliding, pivoted or similarly attached so as to prevent its being removed if it:

- a) Gives access to fuses or any other overcurrent protective device, the intended functioning of which requires renewal; or
- b) Is necessary to open the cover in connection with the intended operation of the product.

5.8.2 If the fuse(s) enclosed is intended to provide protection to portions of internal circuits, such as may be used on a separate printed-wiring board or circuit subassembly to prevent excessive circuit damage resulting from a fault, a hinged cover is not required. The following or equivalent marking shall be indicated on the cover if the risk of electric shock is present:

"CAUTION – Circuit Fuse(s) – Disconnect Power Prior To Servicing."

5.8.3 Where a hinged cover is required, it shall be provided with a latch, screw, or catch to hold it closed. The hinged cover of a product intended to be installed where it will be accessible to other than authorized personnel shall be provided with a key lock or with a screw requiring a tool for removal.

6 Corrosion Protection

6.1 Iron and steel parts, other than bearings and similar parts where such protection is impractical, shall be protected against corrosion by enameling, galvanizing, sherardizing, plating, or other means determined to be equivalent.

Exception No. 1: This requirement does not apply to minor parts, such as washers, screws, bolts, and similar parts if the failure of such unprotected parts would not be likely to result in a hazardous condition or adversely affect the operation of the product.

Exception No. 2: Parts made of stainless steel, polished or treated, if necessary, do not require additional protection against corrosion.

6.2 The requirement in 6.1 applies to all enclosures of sheet steel or cast iron and to all springs and other parts upon which proper mechanical operation may depend.

6.3 Bearing surfaces shall be of such materials and design as to resist binding due to corrosion.

6.4 Metal shall not be used in combinations such as to cause galvanic action.

7 Field-Wiring Connections

7.1 General

7.1.1 Wiring terminals or leads shall be provided for connection of conductors of at least the size required by the National Electrical Code, ANSI/NFPA 70.

7.2 Supply connections

7.2.1 Permanently-connected equipment

7.2.1.1 A product intended for permanent installation shall have provision for connection of metal-clad cable or conduit, or a nonmetallic-enclosed wiring system, for example, nonmetallic sheathed cable.

Exception: An enclosure without provision for the connection of metal-clad cable, conduit, or a nonmetallic-enclosed wiring system may be used if there are furnished with it definite instructions indicating the section(s) of the product intended to be drilled in the field for the connection(s).

7.2.2 Cord-connected equipment

7.2.2.1 Portable equipment and fixed or stationary equipment, requiring cord connections to facilitate use or disconnection for maintenance and repair, may be provided with a flexible cord and attachment plug for connection to the supply source.

7.2.2.2 The type of cord and plug used for the connection shall be determined to be acceptable for the maximum current and voltage to which the product will be subjected in service. The flexible cord shall be SJO, SJT, SJTO, SO, ST, or STO and not less than 6 feet (1.8 m) in length. The cord may be less than 6 feet if the use of the longer cord may result in a hazard.

7.2.2.3 A field-wiring terminal shall comply with the requirements in:

- a) The Standard for Wire Connectors and Soldering Lugs for Use with Copper Conductors, UL 486A;
- b) The Standard for Equipment Wiring Terminals for Use with Aluminum and/or Copper Conductors, UL 486E;
- c) The field-wiring requirements (Code 2) in the Standard for Terminal Blocks, UL 1059;
- d) The field-wiring requirements in the Standard for Electrical Quick-Connect Terminals, UL 310; or
- e) 7.3.1.3 – 7.3.1.6.

The current-carrying parts shall be silver, copper, a copper alloy, or a similar nonferrous conductive material. Securing screws and similar parts may be plated steel. Equipment provided with quick-connect terminals intended for field termination of electrical conductors to the equipment and complying with UL 310 shall be provided with strain relief and the installation instructions shall include instructions for effecting the strain relief and include reference to the specific connectors to be used.

7.3 Field-wiring terminals

7.3.1 High-voltage circuits

7.3.1.1 The terminals to which wiring connections are made are to consist of binding screws with terminal plates having upturned lugs or the equivalent to hold the wires in position. Other terminal connections may be provided if determined to be equivalent. See 7.2.2.3.

7.3.1.2 A field-wiring terminal shall be secured against turning or shifting in position. This may be accomplished by the following means:

- a) Two screws or rivets;
- b) Square shoulders or mortises;
- c) A dowel pin, lug, or offset; or
- d) A connecting strap or clip fitted into an adjacent part.

Friction between surfaces shall not be provided as the sole means for preventing movement of the terminals.

7.3.1.3 A wire binding screw intended for connection to the power supply (line voltage) source shall not be smaller than No. 10 (4.8 mm diameter). The screw may be of plated steel.

Exception: A No. 8 (4.2 mm diameter) screw may be used for the connection of one No. 14 AWG (2.1 mm²) or smaller conductor and a No. 6 (3.5 mm diameter) screw may be used for the connection of one No. 16 AWG (1.3 mm²) or smaller conductor.

7.3.1.4 A wire binding screw shall thread into metal.

7.3.1.5 Except as noted in 7.3.1.6, a terminal plate tapped for a wire binding screw shall be of metal not less than 0.050 inch (1.27 mm) in thickness for a No. 8 (4.2 mm diameter) or larger screw, and not less than 0.030 inch (0.76 mm) in thickness for a No. 6 (3.5 mm diameter) screw and shall have no fewer than two full threads in the metal.

7.3.1.6 A terminal plate formed from stock having the minimum required thickness may have the metal extruded at the tapped hole for the binding screw so as to provide two full threads; except that two full threads are not required if a lesser number of threads results in a connection in which the threads will not strip using tightening torques conforming with the values indicated in the Standard for Wire Connectors and Soldering Lugs for Use with Copper Conductors, UL 486A.

7.3.2 Low-voltage circuits

7.3.2.1 Terminals in low-voltage circuits to which field connections are to be made shall consist of any of the following configurations:

- a) Same as for high-voltage circuits, see 7.3.1.1 – 7.3.1.6.
- b) Nonferrous wiring binding screws not smaller than No. 4 (2.8 mm diameter) for a No. 19 AWG (0.65 mm²) or smaller conductor.
- c) Nonferrous solder lugs.
- d) Terminal connections determined to be equivalent to any of the above.

7.4 Leads

7.4.1 General

7.4.1.1 Wiring of circuits which operate at different potentials shall be separated by barriers, clamps, routing, or other means determined to be equivalent, unless all conductors are provided with insulation rated for the highest voltage involved.

7.4.2 High-voltage circuits

7.4.2.1 Leads provided for field connections in high-voltage circuits may be less than 6 inches (152 mm) in length if the use of longer leads might result in damage to the insulation. In addition, leads shall not be smaller than No. 14 AWG (2.1 mm²), have insulation not less than 1/32 inch (0.8 mm) thick or that determined to be equivalent, and be provided with strain relief.

7.4.3 Low-voltage circuits

7.4.3.1 Leads provided for field connections in low-voltage circuits may be less than 6 inches (152 mm) in length if the use of longer leads might result in damage to the insulation. In addition, leads shall not be smaller than No. 22 AWG (0.36 mm²), have insulation not less than 1/64 inch (0.4 mm) thick or that determined to be equivalent, and be provided with strain relief.

Exception: Solid copper leads as small as No. 26 AWG (0.13 mm²) may be used if:

- a) The current does not exceed 1 ampere for lengths up to 2 feet (61 cm) and the current does not exceed 0.4 ampere for lengths up to 10 feet (3.05 m),*
- b) There are two or more conductors and they are covered by a common jacket or that determined to be equivalent,*
- c) The assembled conductors comply with the requirement in 30.2.1 for strain relief, and*
- d) The installation instructions shall indicate that the lead shall not be spliced to a conductor larger than No. 18 AWG (0.82 mm²).*

7.5 Equipment grounding connection

7.5.1 A product shall be provided with an identified separate equipment grounding terminal or lead. The grounding means shall be connected to all exposed dead metal parts and all dead metal parts within the enclosure which are exposed to contact during servicing or use.

7.5.2 The following are considered to constitute means for grounding:

- a) A knockout or equivalent opening in the metal enclosure, in a product intended to be permanently connected by a metal-enclosed wiring system or
- b) An equipment grounding terminal or lead, in a product intended to be connected by a nonmetal-enclosed wiring system such as nonmetallic-sheathed cable or multiple-conductor cord.

7.5.3 A field-wiring terminal screw intended for the connection of an equipment-grounding conductor shall have a green-colored head that is hexagonal, slotted, or both. A pressure wire connector intended for connection of such a conductor shall be plainly identified, using an appropriate symbol such as "G," "GR," "GROUND," "GROUNDING," or equivalent marking, or by a marking on a wiring diagram provided on the product. The field-wiring terminal shall be so located that it is unlikely to be removed during normal servicing of the product and shall be of such size as to receive a conductor as large as the supply conductors to the product.

7.5.4 The surface of an insulated lead intended solely for the connection of an equipment-grounding conductor shall be green, with or without one or more yellow stripes. No other lead shall be so identified. The lead shall be at least 6 inches (152 mm) long unless it is evident that the use of longer leads would result in a hazard. The lead shall be a conductor as large as the supply conductors for the product.

7.5.5 If a multiple-conductor cord is used, the insulation of the grounding conductor shall be green, with or without one or more yellow stripes. The grounding conductor shall be secured to the grounding terminal or lead at the enclosure and to the grounding blade or equivalent contacting member of an attachment-plug cap. In no case shall a green-identified conductor of a cord be used as a circuit conductor. Ordinary solder alone shall not be used for securing the grounding conductor.

7.6 Grounded supply conductor connection

7.6.1 A field-wiring lead intended for the connection of a grounded power-supply conductor shall be finished to show a white or natural grey color and shall be readily distinguishable from the other leads.

7.6.2 A field-wiring terminal intended for the connection of a grounded (neutral) power-supply conductor shall be identified by means of a metallic plated coating substantially white in color and shall be readily distinguishable from the other terminals, or proper identification of the terminal shall be clearly shown in some other manner, such as on an attached or referenced wiring diagram.

7.7 Field-wiring compartments

7.7.1 A compartment provided for making field connections in a product shall be of sufficient volume to assure proper connections to all field-wiring terminals and/or leads without damage to wire insulation or internal components.

7.7.2 Protection from sharp edges for the internal components and wire insulation shall be provided by insulation or metal barriers having smooth, rounded edges.

7.8 Strain relief

7.8.1 A strain relief means shall be provided for a power supply cord and supply leads to prevent the transmission of stress to terminals, internal connections, or components.

7.8.2 Clamps of any material (metal or otherwise) may be used on cords and supply leads without varnished-cloth insulating tubing or the equivalent under the clamp unless the tubing or the equivalent is necessary to prevent the clamp from damaging the cord or supply leads.

7.8.3 Means shall be provided to prevent the supply cord or supply leads from being pushed into the product through the cord-entry hole if such displacement is likely to subject the cord or supply leads to mechanical damage, or to exposure to a temperature higher than that for which the cord or supply leads are rated, or is liable to reduce spacings (such as to a metal strain-relief clamp) below the minimum acceptable values, or is likely to damage internal connections or components.

8 Internal Wiring

8.1 General

8.1.1 Internal wiring shall have insulation rated for the potential involved and the temperatures to which it may be subjected. The wiring shall be routed away from moving parts and sharp projections and held in place with clamps, string ties, or equivalent means, unless it is of sufficient rigidity to retain a shape form. Conductors that are used for grounding do not require insulation unless needed for identification.

8.1.2 Leads or a cable assembly connected to parts mounted on hinged covers or moving parts shall be flexible and of sufficient length to permit the full opening of the cover without applying stress to the leads or their connections. The leads shall be secured or equivalently arranged to prevent abrasion of insulation and jamming between parts of the enclosure.

8.1.3 If the use of a short length of insulated conductor is not feasible (for example, short coil lead or the like), electrical insulating tubing may be used. The tubing is not to be subjected to sharp bends, tension, compression, or repeated flexing, and is not to contact sharp edges, projections, or corners. The wall thickness shall conform to the requirements for such tubing, except that for smaller sizes of polyvinyl chloride tubing, 3/8-inch (9.5-mm) or less, the wall thickness at any point shall not be less than 0.017 inch (0.43 mm). For insulating tubing of other types, the thickness shall not be less than that required to provide the required mechanical strength, dielectric properties, heat- and moisture-resistant characteristics at least equal to 0.107-inch thick polyvinyl chloride tubing.

8.1.4 Internal wiring of circuits which operate at different potentials shall be separated by barriers, clamps, routing, or other means determined to be equivalent unless all conductors are provided with insulation which is rated for the highest potential and temperature involved.

8.1.5 Stranded conductor clamped under wire binding screws or similar parts shall have the individual strands soldered together or equivalently arranged.

8.2 Barriers

8.2.1 If a barrier of insulating material is used to separate wiring, it shall not be less than 0.028 inch (0.71 mm) thick and shall be of thickness sufficient to ensure that movement of the wires during servicing or normal product operation will not deform the barrier and reduce the separation. Any clearance between the edge of a barrier and a compartment wall shall not be more than 1/16 inch (1.6 mm).

8.3 Wireways

8.3.1 Wireways shall be smooth and free from sharp edges, burrs, fins, or moving parts which may cause abrasion of the conductor insulation. See 8.5.1 – 8.5.6.

8.4 Splices

8.4.1 All splices and connections shall be mechanically secure and bonded electrically.

8.4.2 A splice shall be provided with insulation equivalent to that of the wires involved if permanence of spacings between the splice and uninsulated metal parts is not assured.

8.4.3 Splices shall be located, enclosed, or supported so they are not subject to damage, flexing, motion, or vibration.

8.5 Bushings

8.5.1 At a point where a lead or wire harness passes through an opening in a wall, barrier, or enclosing case, there shall be a bushing or the equivalent which shall provide a smooth, rounded surface against which the wire may bear.

8.5.2 If the cord hole is in phenolic or other non-conductive material or in a metal of thickness greater than 0.042 inch (1.07 mm), a smooth, rounded surface at the hole is considered to be the equivalent of a bushing.

8.5.3 Ceramic materials and some molded compositions may be used for insulating bushings; but bushings of wood or hot-molded shellac may not be used.

8.5.4 Ordinary vulcanized fiber may be used where:

- a) It will not be subjected to a temperature higher than 90°C (194°F) under intended operating conditions,
- b) The bushing is not less than 3/64 inch (1.2 mm) in thickness, and
- c) It will not be exposed to moisture.

8.5.5 A soft rubber bushing may be used in the frame of a motor if the bushing is not less than 3/64 inch (1.2 mm) in thickness and if the bushing is so located that it will not be exposed to oil, grease, oily vapor, or other substances which may have a deleterious effect on rubber. If a soft rubber bushing is used in a hole in metal, the hole shall be free from sharp edges, burrs, projections, and similar defects, which could cut into the rubber.

8.5.6 An insulating metal grommet may be used in lieu of an insulating bushing, provided that the insulating material:

- a) Is not less than 1/32 inch (0.8 mm) thick and
- b) Fills completely the space between the grommet and the metal in which it is mounted.

8.6 Strain relief

8.6.1 A strain relief means shall be provided for internal wires or wire harnesses and cables which are subject to movement in conjunction with the operation or servicing of any product to prevent the transmission of stress to terminals, connections, or components. Movement of conductors provided with a metal ring type of strain relief shall not damage connections or components.

9 Bonding for Grounding

9.1 Exposed noncurrent carrying metal parts likely to become energized shall be bonded to the point of connection of the field equipment grounding terminal or lead and to the metal surrounding the knockout, hole, or bushing provided for field power supply connections.

9.2 Uninsulated metal parts of cabinets, electrical enclosures, and mounting brackets, capacitors, and other electrical components likely to become energized are to be bonded if they may be contacted by the user or by service personnel in servicing the equipment.

9.3 A bonding conductor shall be of material determined to be acceptable for use as an electrical conductor. If of ferrous metal, it shall be protected against corrosion by painting, plating, or the equivalent. The conductor shall have the current carrying capacity of the maximum size wire used in the circuit wiring of the component or part, and shall be installed so that it is protected from mechanical damage.

9.4 The bonding shall be by a positive means, such as clamping, riveting, bolted or screwed connection, brazing, or welding. The bonding connection shall reliably penetrate non-conductive coatings such as paint. Bonding around a resilient mount shall not depend on the clamping action of rubber or similar material.

9.5 A bolted or screwed connection that incorporates a star washer under the screwhead may be used for penetrating non-conductive coatings where required for compliance with 9.4.

9.6 Two or more screws or two full threads of a single screw engaging metal may be used where the bonding means depends upon screw threads.

9.7 Two full threads for a single screw are not required if a lesser number of threads results in a secure connection in which the threads will not strip using the tightening torques conforming with the values indicated in the Standard for Wire Connectors and Soldering Lugs for Use with Copper Conductors, UL 486A.

9.8 Splices shall not be used in wire conductors used to bond electrical enclosures or other electrical components.

10 Electrical Components

10.1 Printed-wiring boards

10.1.1 The securing of components to the board shall be made in a reliable manner and the spacings between circuits shall comply with the requirements in Spacings, Section 11. The board shall be mounted so that deflection of the board during servicing shall not result in damage to the board or in a risk of fire or electric shock.

10.2 Coil windings

10.2.1 Insulation of coil windings or relays, transformers, and similar parts shall be of the moisture resistant type.

10.2.2 Film-coated wire is not required to be given additional treatment to prevent moisture absorption.

10.3 Switches

10.3.1 A switch provided as part of a product shall be rated for the current and voltage of the circuit that it controls when the product is operated under any condition of intended service.

10.4 Semiconductors

10.4.1 Semiconductors shall be rated for the intended application under all environmental conditions to which they will be exposed in service.

10.4.2 The performance tests of the complete product are intended to show the effects of these conditions. The specified tests may be supplemented where conditions exceeding those represented by the tests indicated in this standard may be encountered.

10.5 Lampholders and lamps

10.5.1 Lampholders and lamps shall be rated for the current and voltage in the circuit in which they are used when the product is operated under intended service conditions.

10.5.2 The outer shell of any lampholder in a product shall be connected to the identified (grounded) conductor, if it is in a high-voltage circuit.

10.5.3 A lampholder shall be installed so that uninsulated high-voltage live parts other than an outer shell will not be exposed to contact by persons removing or replacing lamps.

10.6 Protective devices

10.6.1 Fuseholders, fuses, and circuit breakers provided on a product shall be rated for the application.

10.7 Current-carrying parts

10.7.1 A current-carrying part shall be of silver, copper, a copper alloy, or other material that will provide equivalent performance.

10.7.2 Bearings, hinges, and similar parts, shall not be used for carrying current between interrelated fixed and moving parts.

10.8 Insulating material

10.8.1 Material for the mounting of current-carrying parts shall be porcelain, phenolic composition, cold molded composition, or material determined to be equivalent.

10.8.2 Polymeric materials may be used for the sole support of uninsulated live parts if found to have mechanical strength and rigidity, dielectric withstand, resistance to heat, flame propagation, arcing, creep, moisture, and other properties equal to or exceeding the minimum level as a result of aging.

10.8.3 Vulcanized fiber may be used for insulating bushings, washers, separators, and barriers, but not as the sole support of live parts.

10.8.4 The thickness of a flat sheet of insulating material such as impregnated composition or phenolic composition, used for panel-mounting of parts, shall not be less than that indicated in Table 10.1.

Table 10.1
Thickness of flat sheets of insulating material

Maximum dimensions				Minimum thickness, ^a	
Length or width,		Area,			
inches	(cm)	inches ²	(cm ²)	inch	(mm)
24	60.9	360	2322	3/8	9.5
48	122.0	1152	7432	1/2	12.7
48	122.0	1728	11,148	5/8	15.9
over 48	122.0	over 1728	11,148	3/4	19.1

^a Material less than 3/8 inch (9.5 mm) thick may be used for a panel if the panel is adequately supported or reinforced to provide rigidity not less than that of a 3/8 inch sheet. Material less than 1/8 inch (3.2 mm) may be used for subassemblies, such as supports for terminals for internal wiring, resistors, and other components.

10.8.5 A terminal block mounted on a metal surface shall be provided with an insulating barrier between the mounting surface and all live parts on the underside of the base that are not staked, upset, sealed, or equivalently prevented from loosening so as to prevent such parts and the ends of replaceable terminal screws from coming in contact with the supporting surface.

10.8.6 A countersunk part that is sealed shall be covered with a waterproof insulating compound that will not melt at a temperature 15°C (27°F) higher than the maximum normal operating temperature of the assembly, and at not less than 65°C (149°F) in any case. The depth or thickness of sealing compound shall not be less than 1/8 inch (3.2 mm).

10.9 Mounting of components

10.9.1 All components of a product shall be securely mounted in position and prevented from turning or loosening if such motion may reduce electrical spacings or affect the performance of the product.

10.9.2 Uninsulated live parts, including terminals, shall be secured to their supporting surfaces by methods other than friction between surfaces so that they will be prevented from turning or shifting in position if such motion may result in reduction of spacings to less than those required.

10.9.3 Friction between surfaces shall not be the sole means of preventing a device from turning in its mounting. A small stem-mounted switch or other device having a single hole mounting may be prevented from turning with the use of a lock washer having both spring take-up and an interference lock.

10.10 Motors

10.10.1 Each motor shall drive its maximum intended load during operation of the product without introducing a risk of electric shock or fire.

10.10.2 A motor winding shall resist the absorption of moisture.

10.11 Overload protection

10.11.1 A continuous-duty motor in a permanently-connected product, an automatically controlled fractional-horsepower motor in a product, the motor of a product intended to be operated remotely or unattended, a motor whose operation or failure to operate will not be evident to the operator, and a continuous-duty integral-horsepower motor, shall be provided with overload protection. The protection provided shall be as specified in 10.11.3. For a multispeed motor, the protection shall be effective at all speed settings. See also 10.11.4.

10.11.2 If overloading or stalling of a motor can result from manipulation of the controls in any part of the system, that motor shall be provided with overload protection as described in 10.11.3.

10.11.3 The overload protection required in 10.11.2 shall consist of one of the following:

- a) Thermal protection complying with the Standard for Overheating Protection for Motors, UL 2111;
- b) Impedance protection complying with UL 2111, when tested as used in the application; or
- c) Other protection that tests show is equivalent to the protection mentioned in (a).

10.11.4 A motor that drives only a blower or fan is considered to have the necessary overload protection if it is protected against locked-rotor conditions only.

10.11.5 A shaded-pole motor having a difference of 1 ampere or less between no-load and locked-rotor currents and having a 2:1 or smaller ratio between locked-rotor and no-load currents is considered to have the necessary overload protection if it is protected against locked-rotor conditions only.

10.11.6 Devices providing overload protection for motors shall be recognized for use on branch circuits to which the product can be connected unless recognized additional protection is provided in the product.

10.11.7 A thermal or overload protective device shall not open the circuit during intended use of the product.

10.11.8 The functioning of an overload protective device provided for a motor as part of a product, whether or not such a device is required, shall not result in a risk of fire, electric shock, or casualty.

10.11.9 If a product includes a motor and if the overload protection of a branch circuit to which the product can be connected does not provide protection for the motor in accordance with the National Electrical Code, ANSI/NFPA 70, such protection shall be included in the product.

11 Spacings

11.1 A product shall provide reliably maintained spacings between uninsulated live parts and dead metal parts and between uninsulated current-carrying parts of opposite polarity. The spacings shall not be less than those indicated in Table 11.1.

Table 11.1
Minimum spacings

Point of application	Voltage range, ^a volts	Minimum spacings ^{b, c}			
		Through air,		Over surface,	
		inch	(mm)	inch	(mm)
To walls of enclosure:					
Cast metal enclosures	0 – 300	1/4	6.4	1/4	6.4
Sheet metal enclosures	0 – 300	1/2	12.7	1/2	12.7
Installation wiring terminals:					
With barriers	0 – 30	1/8	3.2	1/8	3.2
	31 – 150	1/8	3.2	1/4	6.4
	151 – 300	1/4	6.4	3/8	9.5
Without barriers	0 – 30	3/16	4.8	3/16	4.8
	31 – 150	1/4	6.4	1/4	6.4
	151 – 300	1/4	6.4	1/4	6.4
Rigidly clamped assemblies: ^d					
100 volt-amperes maximum ^e	0 – 30	1/32	0.8	1/32	0.8
Other parts except motors	0 – 30	3/64	1.2	3/64	1.2
	31 – 150	1/16	1.6	1/16	1.6
	151 – 300	3/32	2.4	3/32	2.4

^a These are rms values. Equivalent direct current or peak voltages are 42.4 volts for 30 volts rms, 212 volts for 150 volts rms, and 424 volts for 300 volts rms.

Table 11.1 Continued on Next Page

Table 11.1 Continued

Point of application	Voltage range, ^a volts	Minimum spacings ^{b, c}	
		Through air, inch (mm)	Over surface, inch (mm)
<p>^b Measurements are to be made with solid wire of adequate ampacity for the applied load connected to each terminal. In no case is the wire be smaller than No. 18 AWG (0.82 mm²), except that, if the maximum current input to the device is 1 ampere, the measurement may be made with a No. 22 AWG wire (0.32 mm²).</p> <p>^c An insulating liner or barrier of vulcanized fiber, varnished cloth, mica, phenolic composition, or similar material used where spacings would otherwise be insufficient, shall not be less than 0.028 inch (0.71 mm) thick; except that a liner or barrier not less than 0.013 inch (0.33 mm) thick may be used in conjunction with an air spacing of not less than one-half of the through air spacing required. The liner shall be located so that it will not be affected adversely by arcing. Insulating material having a thickness less than that specified may be used if it is suitable for the particular application.</p> <p>^d Rigidly clamped assemblies include such parts as contact springs on relays or cam switches, printed-wiring boards, and similar parts.</p> <p>^e Spacings less than those indicated, but not less than 1/64 inch (0.4 mm), may be used for the connection of integrated circuits and similar components where the spacing between adjacent connecting wires on the component is less than 1/32 inch (0.8 mm).</p>			

11.2 The spacings "To walls of enclosure" in Table 11.1 apply between an uninsulated live part and a:

- a) Wall or cover of a metal enclosure,
- b) Fitting for conduit or metal-clad cable, and
- c) Metal piece attached to a metal enclosure where deformation of the enclosure is liable to reduce spacings.

They are not to be applied to an individual enclosure of a component part within an outer enclosure.

11.3 Within motors, the spacings between uninsulated live parts of opposite polarity and between an uninsulated live part and a dead metal part shall not be less than indicated in Table 11.2.

Table 11.2
Minimum spacings within motors at other than field-wiring terminals

Potential at the points between which the spacings are measured	Parts involved	Diameter of motor frame	Minimum spacings			
			Through air, inch (mm)		Over the surface, inch (mm)	
0 – 125 volts	Commutator or collector rings	7 inches (178 mm) or less ^a	1/16	1.6	1/16	1.6
		More than 7 inches (178 mm) ^a	1/8 ^b	3.2 ^b	3/16 ^b	4.8 ^b
	Elsewhere in the motor	7 inches (178 mm) or less ^a	3/32 ^c	2.4 ^c	3/32 ^c	2.4 ^c
		More than 7 inches (178 mm) ^a	1/8 ^{b, d}	3.2 ^{b, d}	1/4 ^{b, d}	6.4 ^{b, d}
126 – 250 volts	Commutator or collector rings	7 inches (178 mm) or less ^a	1/16	1.6	1/16	1.6
		More than 7 inches (178 mm) ^a	3/16 ^b	4.8 ^b	3/16 ^b	4.8 ^b
	Elsewhere in the motor	7 inches (178 mm) or less ^a	3/32	2.4	3/32	2.4

Table 11.2 Continued on Next Page

Table 11.2 Continued

Potential at the points between which the spacings are measured	Parts involved	Diameter of motor frame	Minimum spacings			
			Through air, inch (mm)		Over the surface, inch (mm)	
251 – 600 volts	Commutator or collector rings and live parts of the brush rigging	More than 7 inches (178 mm) ^a	1/4 ^{b, d}	6.4 ^{b, d}	1/4 ^{b, d}	6.4 ^{b, d}
		7 inches (178 mm) or less ^a	1/8	3.2	1/4	6.4
	Elsewhere in the motor	More than 7 inches (178 mm) ^a	1/4	6.4	3/8	9.5
		7 inches (178 mm) or less ^a	3/8 ^d	9.5 ^d	1/2 ^d	12.7 ^d
		More than 7 inches (178 mm) ^a	3/8 ^d	9.5 ^d	1/2 ^d	12.7 ^d

^a The frame diameter is the diameter, measured in the plane of the laminations, of the circle circumscribing the stator frame, excluding lugs, boxes, and similar parts, used solely for motor mounting, cooling, assembly or connection.

^b Spacings of not less than 3/32 inch (2.4 mm) may be used throughout a universal motor.

^c For a motor rated at 1/3 horsepower (249 watts) or less, these spacings may not be less than 1/16 inch (1.6 mm).

^d Film-coated wire is considered to be an uninsulated live part. However, a spacing of not less than 3/32 inch or (2.4 mm) (over the surface and through air) may be used between film-coated wire (rigidly supported and held in place on a coil) and a dead metal part.

11.4 Film-coated wire is considered to be a bare current-carrying part in determining compliance of a product with the spacing requirements, but film-coating may be used as turn-to-turn insulation in coils.

12 Customer Access Panel

12.1 If the customer access panel is to be exposed to weather, it shall be designed or shielded to prevent accumulations of dust, ice, snow, or rain within the product, and to prevent severe weather conditions from causing a risk of fire or shock or compromising the security of the currency or deposits, or the accuracy of the records.

13 Security Container

13.1 General

13.1.1 These requirements shall apply to any enclosure as defined in 3.18.

13.1.2 A security container shall be provided with a lock as follows:

- a) For a business-hour service security container, a lock complying with the Standard for Key Locks, UL 437, or Combination Locks, UL 768 (Group 1, 1R, 2, or 2M), or the Standard for Delayed-Action Timelocks, UL 887, or high-security electronic locks, Type 1 or Type 2, complying with the requirements for high-security electronic locks.
- b) For a 24-hour service Level 1 security container, a lock complying with UL 768 (Group 1, 1R, or 2M), or UL 887, or a high-security electronic lock, Type 1, complying with the requirements for high-security electronic locks.

c) For a 24-hour service Level 2 security container, a lock complying with UL 768 (Group 1 or 1R), or UL 887, or a high-security electronic lock, Type 1, complying with the requirements for high-security electronic locks.

13.1.3 The locking mechanism is to be so designed and constructed that it may be operated to unlock and lock the security container. The various parts of the locking mechanism shall be so constructed and assembled that any unit or part may be repaired or replaced.

13.1.4 The moving parts of the locking mechanism and the wearing surfaces of parts such as hinges or boltwork shall be so designed that they will resist, without detrimental effects, the wear and tear incident to intended use.

13.1.5 The product and its locking mechanism shall be so constructed as to resist, without detrimental effects, the corrosive influences to which they may be subjected in service.

13.1.6 The frames and door hinges shall be designed to ensure proper alignment of doors and smooth operation of locking bolts.

13.1.7 The security container of a 24-Hour Service, Level 1 or Level 2, automated teller machine that is intended for a freestanding installation (see 3.11) shall be equipped with an anchoring device or devices, that when installed in accordance with the manufacturer's instructions, will withstand the 22,000 pound (97,861 N) static force of an attempt to remove the security container from its location. The force is to be applied in both the vertical and horizontal direction. The release mechanism of each anchoring device shall only be accessible when the door of the security container is open. The ability to withstand a 22,000 pound vertical or horizontal force can be determined by calculating the tensile and shear strength of the anchoring device or devices.

Exception: If the freestanding installation is within a building and the anchoring device(s) cannot be secured to the building structure, it shall be attached to a steel plate at least 4 feet by 8 feet by 1/2 inch thick (1.22 m by 2.44 m by 12.7 mm thick) or the equivalent so as to restrict the removal of the teller machine from the building.

13.1.8 A 24-Hour Service, Level 1 or Level 2, freestanding automated teller machine shall not be equipped with wheels, skids or devices, or with features that will assist in engaging lifting devices, unless they can be removed or rendered inoperative after the unit has been installed.

13.2 24-hour service – level 1

13.2.1 The metal in the security container body shall be equal to solid open-hearth steel at least 1 inch (25.4 mm) in thickness, having an ultimate tensile strength of 50,000 psi (344.7 MPa), either cast or fabricated, and shall be fastened in a manner equal to a continuous 1/4 inch (6.4 mm) penetration weld of open-hearth steel having an ultimate tensile strength of 50,000 psi.

13.2.2 The security container shall have a door with a minimum thickness of material equal to 1 inch (25.4 mm) of open-hearth steel or the equivalent.

13.2.3 Materials other than solid metal may be used for the security container body construction if attack tests using the tools specified in 35.2.1 – 35.2.3 indicate that the material has the resistance to attack at least equal to 1 inch (25.4 mm) thick open-hearth steel having a tensile strength of 50,000 psi (344.7 MPa). See 13.2.4.

13.2.4 The acceptance of materials other than solid metal or solid metal that does not comply with 13.2.1 for the security container body construction is to be based on the Test of Currency Security Container – 24-Hour Service, Section 35.

13.2.5 The acceptance of a Level 1, 24-hour service security container door and locking mechanism is to be based on the Test of Currency Security Container – 24-Hour Service, Section 35.

13.3 24-hour service – level 2

13.3.1 The clearance between the door and jamb shall not exceed 0.006 inch (0.15 mm) or shall be designed so that no direct access is provided through the door or jamb.

13.3.2 The acceptance of a Level 2, 24-hour service security container and its locking mechanism is to be based on the Test of Currency Security Container – 24-Hour Service, Section 35.

13.4 Business hour service

13.4.1 The security container shall be assembled in a manner that will not allow disassembly from the outside without unlocking the container.

13.4.2 The metal of the security container body shall comply with Table 5.1, 5.2, or 5.3 and the minimum sheet thickness shall be 0.053 inch (1.35 mm) for uncoated steel, 0.056 inch (1.42 mm) for zinc-coated steel, and 0.075 inch (1.91 mm) for brass or aluminum.

13.4.3 The acceptance of a business hour service security container and locking mechanism is to be based on the Test of Business Hour Service Automated Teller System, Section 36.

14 Protection of Service Personnel

14.1 Uninsulated parts that involve a risk of release of energy or operate at high-voltage that are made accessible by opening or removing a cover, door, panel, or other closure on or within the unit (see 5.6.9), shall be provided with guards over the parts to minimize the possibility of service personnel unintentionally touching them during any servicing of the product. See also 14.2 and 14.3.

14.2 If parts that must be in motion during servicing operations present a pinching, snagging, cutting, or other mechanical hazard while made accessible by opening or removing a cover, door, panel, or other closure on the unit for the purpose of affording access to the interior of the product, guards shall be provided over the hazardously moving parts to prevent service personnel from unintentionally touching them. See also 14.3.

14.3 If the guards mentioned in 5.6.9, 14.1, and 14.2 must be removed during servicing of the parts mentioned in 14.1 and 14.2, the guards shall be designed and arranged so they can be removed and replaced.

14.4 Internal components (especially those that are likely to involve frequent replacement or adjustment) shall be isolated from the power-supply-connection areas and other locations in which parts are likely to be live during servicing.

14.5 Each power-supply switch for which there is an "off" position marked on a unit shall disconnect all ungrounded conductors of the power-supply circuit when placed in the "off" position.

PERFORMANCE

OVERALL PRODUCT

15 General

15.1 Unless otherwise specified, the performance of an automated teller system shall be investigated by subjecting a representative sample to the following tests.

15.2 Products are to be tested at the test voltage indicated in Table 15.1 and 15.3 for each test unless specified otherwise.

Table 15.1
Test voltages

Nameplate voltage rating ^a	Test voltage
110 to 120	120
220 to 240	240
Other	Marked nameplate rating
^a Products rated at frequencies other than 60 Hz are to be tested at their rated nameplate voltage and frequency.	

15.3 If a product is rated for a range of voltages, such as 110 – 120 volts, the test voltage is to be the highest value of the range.

16 Normal Operation Test

16.1 An automated teller system shall be capable of operating as intended when tested in conjunction with related equipment which may be combined with the product to perform additional functions.

16.2 To determine if the product complies with the requirement of 16.1, it is to be connected to a rated source of supply and to the optional equipment with which it may be intended to operate.

16.3 All program loading or other necessary functions involved in preparing the product to verify and document transactions shall be performed.

17 Input Test

17.1 The input of a product shall not be more than 110 percent of the product current, wattage, or volt-ampere rating when the product is connected to a test voltage in accordance with the requirements in 17.2 and operating at maximum intended load conditions.

17.2 The test voltage for this test is to be the maximum rated voltage for the product. For a product having a single voltage rating, such as 115 volts, maximum rated voltage is to be that single voltage. If the voltage is given in terms of a range of voltages, such as 110 – 120 volts, the maximum rated voltage is the highest value of the range.

18 Voltage Variations Test

18.1 A product shall function at 85 – 110 percent of test voltage without readjustment. Tests shall be conducted at maximum and minimum input voltages.

18.2 The product may fail to operate as intended, but the security of the currency shall not be affected, incorrect records of transactions shall not be made, and a risk of fire or electric shock shall not be created.

19 Jarring Test

19.1 Parts of the product most likely to be affected by jarring resulting from impact or vibration such as might be encountered under service conditions shall withstand the test described in 19.2. Subsequent operation of the product shall not be impaired.

19.2 A product that is capable of being mounted on a wall without extra support or reinforcement is to be mounted as intended to the center of a 6- by 4-foot (1.8- by 1.2-m), 3/4-inch (19.1-mm) thick plywood board which is to be secured in place at four corners. A 3 foot-pound (4.08 J) impact is to be applied to the center of the reverse side of this board by means of a 1.18 pound (0.53 kg), 2 inch (50.8 mm) diameter steel sphere:

- a) Swung through a pendulum arc from a height (h) of 30.5 inches (0.77 m) or
- b) Dropped from a height (h) of 30.5 inches depending upon the mounting of the equipment.

See Figure 19.1.

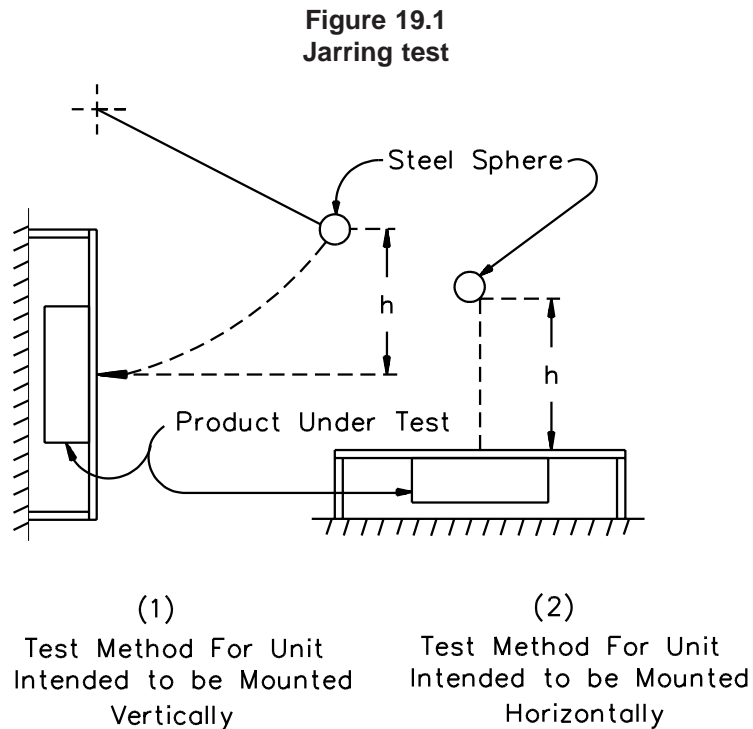

IP110

19.3 A product that is freestanding or requires extra support or reinforcement of the wall for mounting, shall have the impact applied directly to the product at points most likely to affect it.

19.4 For this test, the product is to be energized in a normal ready to serve mode and connected to a rated source of supply. Following the jarring, the product shall be tested for its intended operation.

20 Temperature Test

20.1 The materials used in the construction of a product shall not be adversely affected by the temperatures attained under any condition of intended operation while connected to a source of test voltage and frequency.

20.2 A material will be considered as being adversely affected if it is subject to a temperature rise greater than that indicated in Table 20.1.

Table 20.1
Maximum temperature rises

Materials and components	Ready to serve,		Normal service,	
	°C	(°F)	°C	(°F)
A. MOTORS^{a, b}				
1. Class A insulation systems on coil windings of alternating-current motors 7 inches (178 mm) or less in diameter (not including universal motors):				
a. In open motors:				
Thermocouple or resistance method	75	135	75	135
b. In totally enclosed motors:				
Thermocouple or resistance method	80	144	80	144
2. Class A insulation systems on coil windings of alternating-current motors more than 7 inches (178 mm) in diameter and or direct-current and universal motors:				
a. In open motors:				
Thermocouple or resistance method	65	177	65	117
Resistance method	75	135	75	135
b. In totally enclosed motors:				
Thermocouple method	70	126	70	126
Resistance method	80	144	80	144
3. Class B insulation systems on coil windings of alternating-current motors 7 inches (178 mm) or less in diameter (not including universal motors):				
a. In open motors:				
Thermocouple or resistance method	95	171	95	171
b. In totally enclosed motors:				
Thermocouple or resistance method	100	180	100	180
4. Class B insulation systems on coil windings of alternating-current motors more than 7 inches (178 mm) in diameter and of direct-current and universal motors:				
a. In open motors:				
Thermocouple method	85	153	85	153
Resistance method	95	171	95	171
b. In totally enclosed motors:				
Thermocouple method	90	162	90	162
Resistance method	100	180	100	180
B. COMPONENTS				
1. Capacitors: ^{c, d}				
a. Electrolytic types:	25	45	40	72

Table 20.1 Continued on Next Page

Table 20.1 Continued

Materials and components	Ready to serve,		Normal service,	
	°C	(°F)	°C	(°F)
b. Other types:	25	45	65	117
2. Rectifiers – at any point				
a. Germanium:	25	45	50	90
b. Selenium:	25	45	50	90
c. Silicon:				
(1) Maximum 60 percent of rated volts	50	90	75	135
(2) 61 percent or more of rated volts	25	45	75	135
3. Relay, solenoid, transformer, and other coils with:				
a. Class 105 insulation system:				
Thermocouple method	25	45	65	117
Resistance method	35	63	85	153
Class 130 insulation system:				
Thermocouple method	45	81	85	153
Resistance method	55	99	105	189
c. Class 155 insulation system:				
(1) Class 2 transformers				
Thermocouple method	–	–	95	171
Resistance method	–	–	115	207
(2) Power transformers:				
Thermocouple method	–	–	110	198
Resistance method	–	–	115	207
d. Class 180 insulation system				
(1) Class 2 transformers:				
Thermocouple method	–	–	115	207
Resistance method	–	–	135	243
(2) Power transformers:				
Thermocouple method	–	–	125	225
Resistance method	–	–	135	243
4. Resistors: ^e				
a. Carbon	25	45	50	90
b. Wire wound	50	90	125	225
c. Other	25	45	50	90
5. Solid-state devices			See note f	
6. Other components and materials:				
a. Fiber used as electrical insulation or cord bushings	25	45	65	117
b. Varnished cloth insulation	25	45	60	108
c. Thermoplastic materials	Rise based on temperature limits of the material			
d. Phenolic composition used as electrical insulation or as parts where failure will result in a hazardous condition ^g	25	45	125	225
e. Wood or other combustibles	25	45	125	225
f. Sealing compound	15°C (27°F) less than the melting point			
g. Fuses	25	45	65	117
C. CONDUCTORS				
1. Appliance wiring material ^h	25°C (45°F) less than the temperature limit of the wire			
2. Flexible cord (for example, SJO, SJT)	35	63	35	63
3. Conductors of field-wired circuits to be permanently connected to the product	35	63	35	63

Table 20.1 Continued on Next Page

Table 20.1 Continued

Materials and components	Ready to serve,		Normal service,	
	°C	(°F)	°C	(°F)
D. GENERAL				
1. All surfaces of the product and surfaces adjacent to or upon which the product may be mounted	25	45	65	117
2. Surfaces normally contacted by the user in operating the unit (control knobs, push buttons, levers, and similar parts):				
a. Metal	–	–	35	63
b. Nonmetallic	–	–	60	108
3. Surfaces subjected to casual contact by the user (enclosure, customer access panels, and similar parts):				
a. Metal	–	–	45	81
b. Nonmetallic	–	–	65	117
<p>^a The motor diameter is to be measured in the plane of the laminations of the circle circumscribing the stator frame, excluding lugs, boxes, and similar parts, used solely for motor cooling, mounting, assembly, or connection.</p> <p>^b If the coil is inaccessible for mounting thermocouples (for example, a coil immersed in sealing compound) or if the coil wrap includes thermal insulation or more than two layers, 1/32 inch (0.8 mm) maximum, of cotton, paper, rayon, or similar materials, the resistance method is to be used. For a thermocouple measured temperature of a coil of an alternating-current motor, other than a hermetic motor compressor having a diameter of 7 inches (178 mm) or less, the thermocouple is to be mounted on the integrally applied insulation on the conductor. At a point on the surface of a coil where the temperature is affected by an external source of heat, the temperature measured by a thermocouple may be increased by (not including hermetic motor compressors):</p> <ol style="list-style-type: none"> 1) 5°C (9°F) for Class A insulation on coil windings of alternating-current motors having a diameter of 7 inches (178 mm) or less, open type. 2) 10°C (18°F) for Class B insulation on coil windings of alternating-current motors having a diameter of 7 inches (178 mm) or less, open type. 3) 15°C (27°F) for Class A insulation on coil windings of alternating-current motors having a diameter of more than 7 inches (178 mm), open type. 4) 20°C (36°F) for Class B insulation on coil windings of alternating-current motors having a diameter of more than 7 inches (178 mm), open type. <p>^c For an electrolytic capacitor which is physically integral with or attached to a motor, the temperature rise on insulating material integral with the capacitor enclosure may not be more than 65°C (117°F).</p> <p>^d A capacitor which operates at a temperature higher than a 65°C (117°F) rise may be judged on the basis of its marked temperature rating.</p> <p>^e The temperature rise of a resistor may exceed the values shown if the power dissipation is 50 percent or less of the manufacturer's rating.</p> <p>^f The temperature of a solid-state device (for example, Transistor, SCR, Integrated Circuits) shall not exceed 50 percent of its rating during the Normal Standby Condition. The temperature of a solid-state device shall not exceed 75 percent of its rated temperature under the Alarm Condition or any other condition of operation which produces the maximum temperature dissipation of its components. For reference purposes, 0°C (32°F) shall be considered as 0 percent. For integrated circuits, the loading factor shall not exceed 50 percent of its rating under the Normal Standby Condition and 75 percent under any other condition of operation. Both solid-state devices and integrated circuits may be operated up to the maximum ratings under any one of the following conditions:</p> <ol style="list-style-type: none"> 1) The component complies with the requirements of Test Method for Standard Microcircuits, MIL-STD-883E. 2) A quality control program is established by the manufacturer consisting of an inspection stress test followed by operation of 100 percent of all components, either on an individual basis, as part of a subassembly, or equivalent. 3) Each assembled production unit is subjected to a burn-in test, under the condition which results in the maximum temperatures, for 24 hours while connected to a source of rated voltage and frequency in an ambient of at least 49°C (120°F) followed by a recalibration of the sensitivity and retested. <p>^g The limitations on phenolic composition and on rubber and thermoplastic insulation do not apply to compounds which have been investigated and found to have special heat-resistant properties.</p> <p>^h For standard insulated conductors other than those mentioned, reference should be made to the National Electrical Code, ANSI/NFPA 70. The maximum allowable temperature rise in any case is 25°C (45°F) less than the temperature limit of the wire in question.</p>				

20.3 All values for temperature rises apply to a product intended for use with ambient temperatures normally prevailing, which are usually not higher than 25°C (77°F). If the product is intended specifically for use with a prevailing ambient temperature constantly more than 25°C, the test of the product is made at such higher ambient temperature, and the allowable temperature rises specified in Table 20.1 are to be reduced by the amount of the difference between the higher ambient temperature and 25°C.

20.4 Temperature measurements on a product intended for recessed mounting shall be made with the product installed in an enclosure of 3/4 inch (19.1 mm) plywood having clearances of 2 inches (50.8 mm) on the top, sides, and rear, and the front extended to be flush with the cover of the product. If other clearances are specified in installation instructions, they shall be used.

20.5 A temperature is considered to be constant when three successive readings, taken at 5 minutes, or greater intervals, indicate no change.

20.6 Except at coils, temperatures are to be measured by means of thermocouples consisting of wires not larger than No. 24 AWG (0.21 mm²). The preferred method of measuring the temperature of a coil is the thermocouple method, but a temperature measurement by either the thermocouple or resistance method is acceptable, except that the thermocouple method is not to be used for a temperature measurement at any point where supplementary thermal insulation is used.

20.7 If thermocouples are used in the determination of temperatures in connection with the heating of electrical devices, it is standard practice to use thermocouples consisting of No. 30 AWG (0.05 mm²) iron and constantan wires and a potentiometer-type indicating instrument. Such equipment will be used whenever referee temperature measurements by thermocouples are necessary.

20.8 The temperature rise of a winding is to be calculated using the formula:

$$\Delta t = \frac{R}{r} (k + t_1) - (k + t_2)$$

in which:

Δt is the temperature rise in °C,

R is the resistance of the coil at the end of the test,

r is the resistance of the coil (coil at t_1) at the beginning of the test,

k is 234.5 for copper or 225.0 for electrical-conductor grade aluminum,

t_1 is the temperature in °C at the beginning of the test, and

t_2 is the temperature in °C at the end of the test.

The winding is to be at room temperature at the start of the test.

20.9 As it is generally necessary to de-energize the winding before measuring R, the value of R at shutdown may be determined by taking several resistance measurements at short intervals, beginning as quickly as possible after the instant of shutdown. A curve of the resistance values and the time may be plotted and extrapolated to give the value of R at shutdown.

20.10 To determine compliance with this test, a product is to be connected to a supply circuit of test voltage and frequency and operated under the following conditions:

- a) READY TO SERVE – (7 hours – Constant temperatures).
- b) NORMAL SERVICE, MAXIMUM NORMAL LOAD – (1 hour – Constant temperatures).

20.11 "Normal service" shall be the repeated operation of the dispense function. Other operations shall also be conducted if they energize components not used in the dispense function or if they cause a more severe load condition. The rate of operation shall not exceed 15 operations per minute.

21 Overload Test

21.1 A product shall be subjected to 50 cycles of operation for each of its major functions with the supply circuit energized at 115 percent of test voltage and at rated frequency. Each cycle shall consist of starting with the product energized in the ready to serve mode, "normal service" operation, and restoration to the ready to serve mode.

21.2 A current-interrupting device intended to control loads that are not connected to the product supply terminals and that require a separate supply circuit shall be tested with an overload current of 150 percent of its ampere rating and at the maximum test voltage for 50 cycles.

21.3 The product may be cycled at any rate up to 15 cycles per minute.

21.4 Failure of a component is acceptable if the security of the currency is not affected, if incorrect records of transactions are not made, and a risk of fire or electric shock is not created.

21.5 The Overload Test shall be conducted prior to the Endurance Test, Section 22.

22 Endurance Test

22.1 A product shall be subjected to 6000 cycles of operation at a rate of not more than 15 cycles per minute, with the supply circuit energized at test voltage and at rated frequency. Each cycle shall consist of starting with the product energized in the ready to serve mode, "normal service" operation, and restoration to the ready to serve mode. There shall not be electrical or mechanical failure or evidence of failure by the components.

22.2 Failure of a component is acceptable if the security of the currency or deposits is not affected, if incorrect records of transactions are not made, and a risk of fire or electric shock is not created.

23 Variable Ambient Temperature Test

23.1 A product meant for indoor use shall be exposed to temperatures of 0°C (32°F) and 49°C (120°F).

23.2 If meant for outdoor use, the product or the part of the product designed to be exposed to outdoor conditions shall be subjected to ambient air temperatures of minus 35°C (minus 30°F) and 66°C (150°F).

23.3 A product that is to be used during business hours only shall be exposed to temperatures of 13°C (55°F) and 35°C (95°F).

23.4 The product is to be maintained at each temperature for a sufficient length of time, at least 4 hours, to ensure that thermal equilibrium has been reached and then tested at that temperature for intended operation while connected to a source of rated voltage and frequency.

23.5 The product may fail to operate as intended, but the security of the currency shall not be affected, incorrect records of transactions shall not be made, and a risk of fire or electric shock shall not be created.

24 Humidity Test

24.1 A product shall be operated while energized from a rated source of voltage and frequency during and following exposure for 24 hours to moist air having a relative humidity of 85 percent at a temperature of $30 \pm 2^\circ\text{C}$ ($86 \pm 3^\circ\text{F}$). The performance shall be determined with the product in the humidity environment.

24.2 The product may fail to operate as intended but the security of the currency shall not be affected, incorrect records of transactions shall not be made, and a risk of fire or electric shock shall not be created.

25 Leakage Current Test

25.1 The leakage current of a cord-connected product intended to be located in an area accessible to contact by a person, or which is interconnected to a product that is accessible to contact by a person shall be determined in accordance with the American National Standard for Leakage Current for Appliances, ANSI C101-1992, immediately after exposure to the Humidity Test, Section 24.

25.2 A product that is accessible to contact by a person and which is interconnected to a cord-connected product, shall be tested for leakage current as specified in 25.1 while it is interconnected to the cord-connected product.

25.3 The leakage current test sequence, with reference to the measurement circuit in Figure 25.1, is to be as follows:

a) With switch S1 open, the product is to be connected to the measurement circuit. Leakage current is to be measured using both positions of switch S2. All manual switching devices are then to be operated in their intended manner. Leakage current is to be measured using both positions of switch S2.

b) With the product switching devices in their intended operation positions, switch S1 is then to be closed, energizing the product, and within a period of 5 seconds, the leakage current is to be measured using both positions of switch S2. All manual switching devices are then to be operated in their intended manner, and leakage currents measured using both positions of switch S2.

c) The product switching devices are then to be returned to their intended operating positions and the product allowed to operate until thermal equilibrium is obtained. Leakage current is to be monitored continuously. For this test, thermal equilibrium is defined as that condition where leakage current is found to be constant or decreasing in value. Both positions of switch S2 are to be used in determining this measurement.

d) Immediately following the test, any single-pole switch on the product is to be opened, and the leakage current monitored until constant or decreasing values are recorded. Readings are to be taken in both positions of switch S2.

Figure 25.1
Leakage current measurement circuits

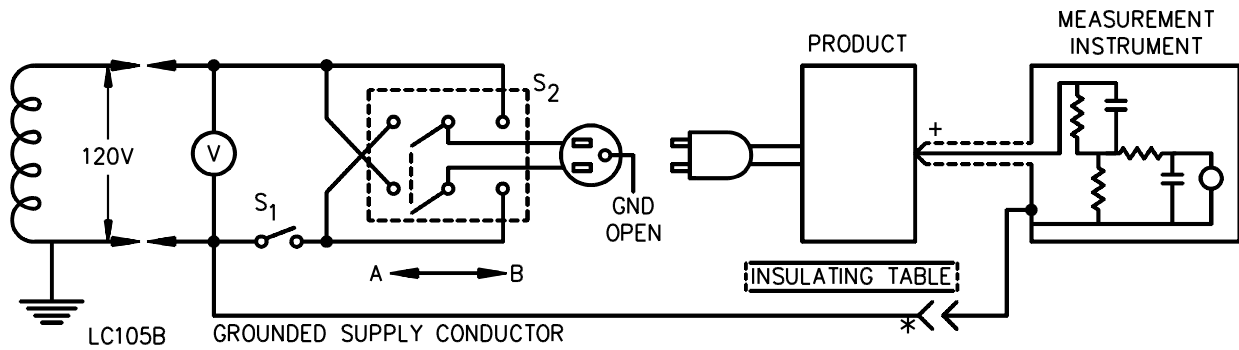

Circuit used for products intended for connection to 120-volt circuits

Figure 25.1 Continued

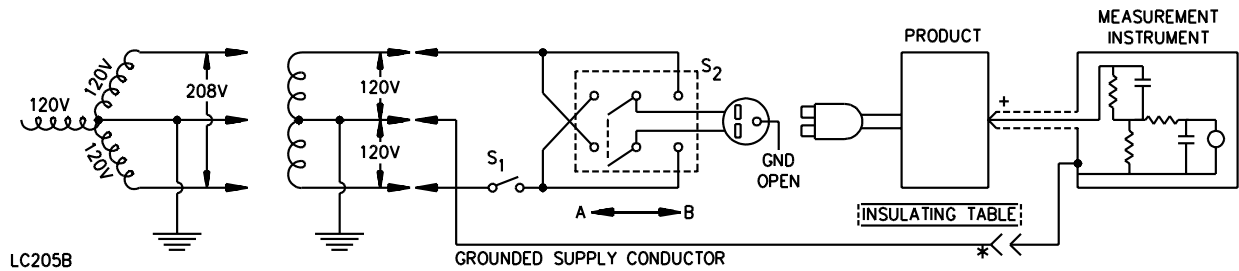

Circuit used for grounded or ungrounded 208-volt or 240-volt products intended for connection to three-wire neutral grounded circuits

* Separated and used as a clip when measuring currents from one part of product to another.

+ Probe with shielded lead.

NOTES

1 All voltages shown are nominal.

2 If it is not feasible to isolate the product from ground, the supply circuit shall be isolated from ground. It may then also be necessary to reverse the leads of the measurement instrument.

26 Transient Test

26.1 A product shall be subjected to 500 externally induced transients while energized from a test voltage source of supply.

26.2 The primary of a 120/240-volt, 60-Hz, 2-kilovolt-ampere (kVA) isolating power transformer with the secondary open circuited is to be connected to the same branch circuit as the product. The input to the transformer is to be de-energized for approximately 1 second by an automatic switching device at a rate of not more than 6 cycles per minute for 500 cycles. During the test, the product is to be energized in the ready to serve condition. Following the test the product is to be operated for its intended service operation to determine whether transients, generated by the random collapse of the magnetic field of the transformer, result in a component failure or adversely affect its intended performance.

26.3 The product may fail to operate as intended, but the security of the currency shall not be affected, incorrect records of transactions shall not be made, and a risk of fire or electric shock shall not be created.

26.4 The electrical characteristics of the testing transformer are specified in Table 26.1.

Table 26.1
Electrical characteristics of the testing transformer

Winding	Voltage, volts (V)	Frequency, hertz (Hz)	Inductance, millihenries (mH)	Quality factor, (Q)	DC resistance ohms (Ω), 73.4°F (23°C)
Primary	120	1000	21.2	11.50	0.244
Secondary	240	1000	109.3	4.65	0.371

NOTE – A transformer suitable for this purpose is Jefferson Electric Model 211-091 rated 2 kVA, 120/240 volt, 1 phase, 60 Hz.

27 Rain Test

27.1 The parts of a product exposed to weather shall withstand a rain exposure for 1 hour without creating a risk of electric shock or affecting its subsequent operation. The assembly shall also comply with 27.8 after the test.

27.2 The product is to be operated so that electrical components are energized and the product tested under the conditions judged most likely to cause the entrance of water into or on electrical components. It may be necessary to operate the product under various modes of operation or to de-energize the product if more adverse conditions could result. In any case, each exposure is to be for 1 hour. If more than one exposure is required, the product is to be prepared for test as indicated in 27.4 before the test is repeated.

27.3 Field-wiring connections are to be made in accordance with the wiring method specified for the product. Openings intended to terminate conduit are to be sealed. Openings intended for the entry of a conductor or conductors for Class 2 wiring in a low-voltage circuit are not to be sealed unless a seal is provided as a part of the product.

27.4 Except as indicated in 27.5, the product is to be examined to determine that all electrical parts, including motor windings, are not wetted and that there is no accumulation of water within the enclosures of electrical parts prior to rain exposure.

27.5 Drying of the product prior to the second or subsequent exposure is not required if, without such preparation, the product complies with the requirement in 27.6.

27.6 After each exposure the product is to have an insulation resistance between live parts and dead metal parts of not less than 50,000 ohms. The insulation resistance is measured 1 minute after application of the voltage obtained by using the series-voltmeter method, or means determined to be equivalent, and a direct current circuit. After measurement of the insulation resistance, the complete product is to be subjected to the Dielectric Withstand Test, Section 29.

27.7 The rain test apparatus is to consist of three spray heads mounted in a water supply pipe rack as shown in Figure 27.1. Spray heads are to be constructed in accordance with the details shown in Figure 27.2. The water pressure for all tests is to be maintained at 5 psig (34.5 kPa) at each spray head. The distance between the center nozzle and the product is to be approximately 5 feet (1.5 m). The product is to be brought into the focal area of the three spray heads in such a position and under such conditions that the greatest quantity of water will enter the product. The spray is to be directed at an angle of 45 degrees to the vertical toward the louvers or other openings closest to live parts.

Figure 27.1
Rain test apparatus
PLAN VIEW

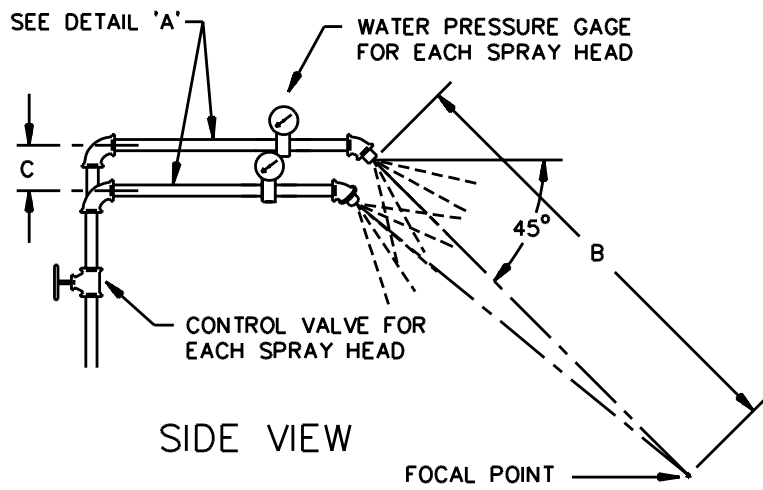
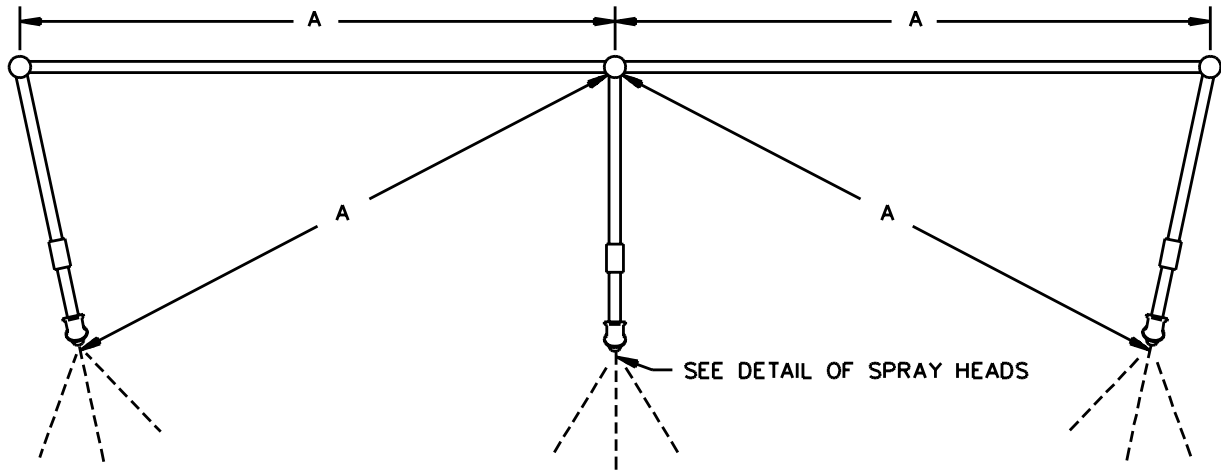

PIEZOMETER ASSEMBLY
DETAIL 'A'

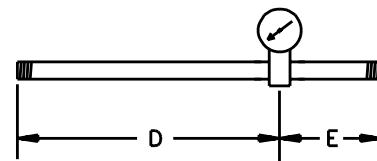

Item	inch	mm
A	28	710
B	55	1400
C	2-1/4	55
D	9	230
E	3	75

RT101E

Figure 27.2
Rain-test spray head

ASSEMBLY^a

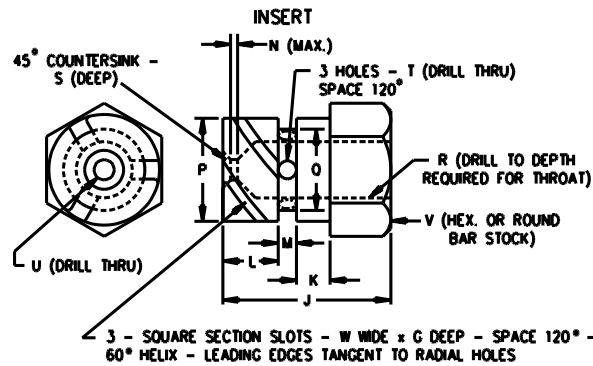
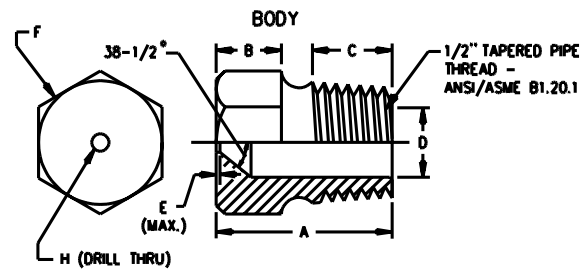
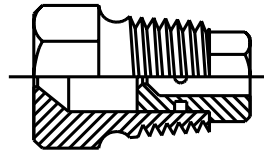

Item	inch	mm	Item	inch	mm	
A	1-7/32	31.0	N	1/32	0.80	
B	7/16	11.0	P	.575	14.61	
C	9/16	14.0	Q	.576	14.63	
D	.578	14.68	R	.453	11.51	
E	.580	14.73	S	.454	11.53	
F	1/64	0.40	T	1/4	6.35	
G	c	c	U	1/32	0.80	
H	(No. 9) ^b	5.0	V	(No. 35) ^b	2.80	
J	23/32	18.3	W	(No. 40) ^b	2.50	
K	5/32	3.97		V	5/8	16.0
L	1/4	6.35		W	0.06	1.52
M	3/32	2.38				

^a Nylon Rain-Test Spray Heads are available from Underwriters Laboratories

^b ANSI B94.11M Drill Size

^c Optional - To serve as a wrench grip.

RT100E

27.8 The test is not to result in the entrance of water into enclosures above the lowest electrical component other than insulated wire or the wetting of high-voltage live parts, except that:

- a) Motor windings may be judged on the basis of the insulation resistance and by the Dielectric Withstand Test, Section 29, if the motor is within the enclosure and is shielded from openings in the top of the enclosure.
- b) Water may enter an enclosure above the lowest electrical component if the point of entrance is not in proximity to high-voltage live parts and high-voltage live parts are not wetted during the Rain Test.

28 Ignition Test

28.1 General

28.1.1 Both of the bottom-panel constructions described in 5.2.4 are not required to be tested. Other constructions are capable of being used when they pass the test described in 28.2.1 – 28.2.4.

Exception: This test does not apply to low-voltage, power-limited products in which an internal fault does not produce flame, molten metal, flaming or glowing particles, or flaming drops.

28.2 Hot flaming oil

28.2.1 Openings in a bottom panel shall be so arranged and sufficiently small in size and few in number that hot flaming No. 2 fuel oil poured three times onto the openings from a position above the panel is extinguished as it passes through the openings.

28.2.2 A sample of the complete, finished bottom panel is to be securely supported in a horizontal position several inches above a horizontal surface under a hood or in another area that is well ventilated but free from significant drafts. Bleached cheesecloth running 14 – 15 square yards to the pound (26 – 28 m²/kg) and having a thread count of 32 by 28 per inch square (per 25.4 mm square) is to be draped in one layer over a shallow, flat-bottomed pan that is of sufficient size and shape to cover completely the pattern of openings in the panel but is not large enough to catch any of the oil that runs over the edge of the panel or otherwise does not pass through the openings. The pan is to be positioned with its center under the center of the pattern of openings in the panel. The center of the cheesecloth is to be 2 inches (50.8 mm) below the openings. Use of a metal screen or wired-glass enclosure surrounding the test area is recommended to prevent splattering of the oil from causing injury and doing other damage.

28.2.3 A metal ladle [preferably not more than 2-1/2 inches (64 mm) in diameter], with a pouring lip and a long handle whose longitudinal axis remains horizontal during pouring, is to be partially filled with 10 cubic centimeters of No. 2 fuel oil, which is a medium-volatile distillate having an API gravity of 32 – 36 degrees, a flash point of 110 – 190°F (43 – 88°C), and an average calorific value of 136,900 Btu per gallon (38.12 MJ/liter). See Specifications for Fuel Oils, ASTM D396-98. The ladle containing the oil is to be heated and the oil ignited and allowed to burn for 1 minute, at which time all of the hot, flaming oil is to be poured at the rate of approximately and not less than 1 cubic centimeter per second in a steady stream onto the center of the pattern of openings from a position 4 inches (102 mm) above the openings. It is to be observed whether the oil ignites the cheesecloth.

28.2.4 Five minutes after completion of the pouring of the oil, the cheesecloth is to be replaced with a clean piece and a second 10 cubic centimeters of hot, flaming oil is to be poured from the ladle onto the openings and it is again to be observed whether the cheesecloth is ignited. Five minutes later, a third identical pouring is to be made. The openings are not acceptable if the cheesecloth is ignited in any of the three pourings.

29 Dielectric Withstand Test

29.1 A product shall be capable of withstanding for 1 minute without breakdown, the application of a 40 – 70 Hz alternating potential between all live parts and the enclosure, between all live parts and exposed dead-metal parts, except as indicated in 29.2, and between live parts of circuits operating at different potentials or at different frequencies. The test potential between live parts of circuits operating at different potentials or frequencies shall be the value determined by the higher voltage of the different circuits. The test potential shall be:

- a) 500 volts for low-voltage circuits;
- b) 1000 volts between the frame and windings of a motor rated 1/2 horsepower (373 watts) or less and 250 volts or less; and
- c) 1000 volts plus twice the rated voltage for high-voltage circuits.

29.2 Exposed dead-metal parts referred to in 29.1 are noncurrent-carrying metal parts which are likely to become energized and accessible from outside of the enclosure of a product during normal operation with the door of the enclosure closed.

29.3 To determine compliance with 29.1 and 29.2, a 500 VA or larger transformer, the output-voltage of which is essentially sinusoidal and can be varied, is to be used. The applied potential is to be increased gradually from zero until the required test value is reached and is to be held at that value for 1 minute. The requirement of a 500 VA or larger transformer can be waived if the high potential testing equipment used is such that it maintains the specified high potential voltage at the product for the duration of the test.

29.4 A printed-wiring assembly shall be capable of withstanding without breakdown, for a period of 1 minute, the application of a direct current potential between printed-wiring parts of opposite polarity and between printed-wiring parts of different potential or different frequency. The test potential between printed-wiring parts of different potential or frequency shall be the value determined by the higher voltage of the different circuits. The test potential shall be as follows:

- a) 1000 volts plus twice the rated voltage for high-voltage circuits and
- b) 500 volts for low-voltage circuits where the location and relative arrangement of the parts are such that separation is assured.

29.5 Rated voltage is the maximum peak potential between direct current circuit parts and the maximum rms potential between alternating current circuit parts, measured with the product connected to a supply circuit of maximum rated voltage as described in 15.3.

30 Strain Relief Tests

30.1 Power supply cord

30.1.1 When tested in accordance with 30.1.2, the strain relief means provided for the flexible cord shall be capable of withstanding for 1 minute without displacement, a force of 35 pounds (156 N) applied to the cord with the connections within the product disconnected.

30.1.2 A weight is to be suspended on the cord and so supported by the product that the strain relief means will be stressed from any angle which the construction of the product permits. The strain relief is not acceptable if, at the point of disconnection of the conductors, there is such movement of the cord as to indicate that stress would have resulted on the connections.

30.2 Field-wiring leads

30.2.1 Each lead used for field connections shall be capable of withstanding for 1 minute a force of 10 pounds (44.4 N) without any evidence of damage or of transmitting the stress to internal connections.

30.3 Internal wiring

30.3.1 When tested for compliance with 8.6.1 the strain relief means provided for internal wiring shall withstand for 1 minute a force of 10 pounds (44.4 N) without any evidence of damage or transmission of stress to connections.

31 Flexure Test

31.1 Leads or cables subject to movement during servicing shall be subjected to a flexure test by operating the movable parts for a total of 6000 cycles without developing a risk of fire or electric shock or affecting the security of the currency or deposits, or the accuracy of the records.

31.2 Following the 6000 cycles, the product shall be subjected to the Dielectric Withstand Test, Section 29.

RESISTANCE TO EXPERT ATTACK

32 Objective

32.1 Since the objective of the tests is to arrive at satisfactory conclusions as to the resistance of a product to expert attack, the testing party may select a number of attacks within the scope of the test procedure and try each attack for the full allotted time. The test will be considered acceptable if the product resists the best method or combination of methods applied to a given point or area for the net working time specified.

32.2 The net working time is understood to cover only the period during which an attack is actively in progress on the sample, exclusive of preparations for test, time required for safety-first precautions, and delays which cannot be anticipated.

32.3 Except for trapping, successful attack shall consist of the removal of a minimum of 10 percent of the currency indicators in the product within the specified time, or the exposure of the indicators so that they can all be removed.

32.4 A trapping attack must operate successfully to trap three dispenses without being detected or disrupting the operation of the product. The trap may be adjusted between operations.

32.5 All attacks shall be carried out by one or two experienced operators familiar with the design.

33 Indicators

33.1 The product shall be loaded to its maximum with a representative amount of currency (or equivalent paper) before being subjected to test.

33.2 The product shall not allow the indicators to be removed without being mutilated.

33.3 A currency indicator is not to be considered as being mutilated if three-fifths or more of it remains undamaged as measured from the end. Visible holes produced in the indicator are to be considered as constituting damage, but tears which can be readily mended are not to be judged as damage. Water-soaked indicators are not to be considered as being damaged.

34 Test of Customer Access Panel – 24-Hour Service

34.1 General

34.1.1 A 24-hour service automated teller system shall resist, for a period of 30 working minutes, attempts to remove currency through the customer access panel by means of fishing, trapping, or forcing.

34.1.2 All tests are to be limited to attacks on the customer access panel.

34.2 Tools

34.2.1 The tests are considered relatively quiet attacks, and tools are limited to lines, wires, hooks, pry bars, wrenches, screwdrivers, hacksaw blades, and similar tools, which can be concealed on the clothing of two operators. Except for devices that can be coiled or folded, such as lines, wires, and hooks, no tool shall exceed 24 inches (0.6 m) in length.

34.3 Time

34.3.1 A number of attacks may be attempted, each for the full 30 minutes working time.

34.3.2 Any one attack method shall only be attempted once. Damage caused in one attack may be used in another attack, if the time used to cause the damage in the first attack is deducted from the 30 minute time of the second attack.

34.4 Methods

34.4.1 Fishing, forcing, and trapping attempts, as defined in 3.9, 3.10, 3.21, and 3.22, respectively, shall be determined by the design of the product.

34.4.2 A hammer limited to a 3 pound (1.4 kg) head weight, used separately or with chisels, punches, and screwdrivers limited to 24 inches (0.6 m) in length, may be used for up to a total time of 30 seconds during the test.

35 Test of Currency Security Container – 24-Hour Service

35.1 General

35.1.1 Any or all of the methods of attack specified in 35.5.1 – 35.5.10 may be used at the option of the testing party in an attempt to remove currency from the currency security container.

35.1.2 The door clearances of the test sample shall represent the maximum clearances of the manufacturer's subsequent production.

35.1.3 In addition, complete drawings of the construction together with specifications of the materials shall be furnished.

35.1.4 The test sample shall be accompanied by two tensile strength test specimens, prepared as described in Tension Testing of Metallic Materials, ASTM E8-99, of steel from which the door and body are constructed. The test specimens shall be of 1/2 inch (12.7 mm) diameter and 2 inch (50.8 mm) length.

Exception: If material other than steel is used, these samples are not required.

35.2 Tools – level 1

35.2.1 The test equipment may include any common hand tools, mechanical or portable electric tools, grinding points, carbide drills and picking tools, but shall exclude magnetic drill presses and other pressure-applying mechanisms, abrasive wheels, and rotating saws.

35.2.2 Common hand tools are defined as chisels, drifts, wrenches, screwdrivers, pliers, hammers, and sledges not exceeding 8 pounds mass (3.6 kg) in size, pry bars, ripping tools not exceeding 5 feet (1.5 m) in length, and socket sets.

35.2.3 Picking tools may consist of common or standard patterns, but shall not be specifically designed for use against a special make of product. Portable electric tools are defined as high speed hand held drills of 1/2 inch (12.7 mm) size.

35.3 Tools – level 2

35.3.1 The test equipment may include any tools specified in 35.2.1 – 35.2.3, and may further include impact tools, an oxy-fuel gas cutting or welding torch, abrasive wheels, rotating saws, a magnetic drill press, and other pressure-applying mechanisms.

35.3.2 The quantity of gas consumed in any one test shall be limited to 1000 cubic feet (28.3 m³), combined total oxygen and fuel gas.

35.4 Time

35.4.1 A 24-hour, Level 1 and Level 2 service currency container shall resist expert attack for a period of 15 working minutes. All methods outlined in 35.5.1 – 35.5.10 may be used, each for the full 15 minutes, and using the tools specified.

35.4.2 Any one attack method shall only be attempted once. Damage caused in one attack may be used in another attack, if the time used to cause the damage in the first attack is deducted from the 15 minute time of the second attack.

35.4.3 The container shall be loaded with currency indicators as if in service. A successful attack shall be based on the requirements specified in 32.3.

35.5 Methods

35.5.1 COMBINATION DRIFTING AND DRILLING – An attempt shall be made, by means of picking tools, wire, hooks, or other common hand tools, to knock off the combination dial, punch or drill the spindle, and then release the lock mechanism.

35.5.2 LOCK MECHANISM – An attempt shall be made to gain access through the lock box, lug, carrying bar, or other parts of the mechanism and then release the boltwork by punching, prying, picking, or cutting.

35.5.3 LOCK BOLTS – Through openings made in the door, an attempt shall be made to cut off or drive the main locking bolts out of engagement.

35.5.4 CUTTING LOCK BOLTS – An attempt shall be made to cut through the door jamb and sever the main locking bolts.

35.5.5 RELOCK DRIFTING AND DRILLING – Through means of punching or drilling the combination lock spindle while simultaneously applying force to operate the door handle, an attempt shall be made to release the relocking mechanism. An attempt shall also be made to release the relocking mechanism by using picking tools or other common hand tools.

35.5.6 HANDLE FORCING – An attempt shall be made to force the bolt-operating lever by means of a wrench or pipe applied to rotate the bolt handle, or by punching the bolt handle so as to free the lock connection.

35.5.7 DOOR SLEDGING AND WEDGING – An attempt shall be made to pierce or open the door by means of wedges, chisels, and sledges so as to give access to the currency.

35.5.8 CREATING AN OPENING – LEVEL 1 CONTAINER – An attempt shall be made to create an opening in the door of the currency container by drilling a series of holes in close proximity and then breaking out the section of metal with a sledge hammer.

35.5.9 CREATING AN OPENING – LEVEL 2 CONTAINER – An attempt shall be made to create an opening in the door or body of the currency container using the tools described in 35.3.1.

35.5.10 CURRENCY CONTAINER OPENINGS – An attempt shall be made to force open and fish out the currency through openings that are part of the design in the top, sides, and bottom of the container. Powered tools, such as electric, pneumatic, and similar tools, shall not be used in this test against a Level 1 container but may be used against a Level 2 container. See 35.2.1 – 35.3.2.

36 Test of Business Hour Service Automated Teller System

36.1 General

36.1.1 Attacks against a business hour service automated teller system shall be directed against any door, opening, or seam that may give access to the currency.

36.1.2 Any or all of the methods of attack specified in 36.4.1 – 36.4.10 may be used at the option of the testing party.

36.1.3 The door clearances of the test sample shall represent the maximum clearances of the manufacturer's subsequent production.

36.1.4 In addition, complete drawings of the construction, together with specifications of the materials shall be furnished.

36.2 Tools

36.2.1 The attack tools shall be limited to lines, wires, hooks, pry bars, wrenches, screwdrivers, saws, punches, hammers, chisels, picking tools, and similar tools, which can be concealed on the clothing of two operators.

36.2.2 Except for devices that can be coiled or folded, such as lines, wires, and hooks, no tool is to exceed 24 inches (0.6 m) in length, and hammers are not to exceed 3 pounds (1.4 kg) in head weight.

36.2.3 Powered tools (for example, electric, pneumatic, and similar tools) are not to be used.

36.2.4 Picking tools may consist of common or standard patterns, but are not to be specifically designed for use against a special make of product.

36.3 Attack

36.3.1 A business hour service automated teller system shall resist attempts to remove the currency for periods of time as indicated below.

36.3.2 Attacks that are quiet and unlikely to attract attention are to have a time of 5 working minutes.

36.3.3 Attacks that are carried out without regard to the noise and damage caused, are to have a time of 2 working minutes.

36.4 Methods

36.4.1 The following methods of attack are to be used as well as additional attacks determined by the design of the product.

36.4.2 Any one attack method is to be attempted only once. Damage caused in one attack may be used in another attack, if the time used to cause the damage in the first attack is deducted from the time of the second attack.

36.4.3 The container shall be loaded with currency indicators as if in service. A successful attack shall be judged on the requirements of 32.3.

36.4.4 DOOR FORCING – An attempt is to be made to open any door giving access to the currency by forcing it with pry bars, chisels, hammers, and similar tools.

36.4.5 HANDLE FORCING – An attempt is to be made to force the locking mechanism by means of a wrench or pipe applied to rotate the lock handle, or by punching the handle so as to free the lock connection.

36.4.6 OPENINGS AND SEAMS – Any opening or seam in the product is to be subject to attack in an attempt to gain access to the currency.

36.4.7 KEY LOCK FORCING AND PULLING – Attempts are to be made to disengage a key locking cylinder by forcing or pulling the cylinder and releasing the locking mechanism.

36.4.8 COMBINATION LOCK ATTACK – An attempt is to be made to knock off a combination dial, punch the spindle, and then release the lock mechanism.

36.4.9 FISHING – Attempts are to be made to fish currency from the product as defined in 3.9 and are to be subject to the 5 minute time limit as specified in 36.3.2.

36.4.10 Fishing attacks are to be conducted only if the operation can be performed while appearing to use the automated teller system in the intended manner.

37 Record Protection

37.1 Records of all transactions shall be within the security container or its equivalent or located in one of the following manners.

37.2 The records shall be located in a container complying with the construction requirements as specified in 13.1.1, 13.1.4 – 13.2.1, 13.2.2, and 13.2.3, and the attack resistance requirements as specified in 32.1, 32.2, 32.5, 36.1.1 – 36.2.4, and 36.4.1 – 36.4.9. The attack time is to be limited to 5 minutes without regard to the noise and damage caused.

37.3 If complete duplicate records are separately located within the product where they are intended to be accessible only to authorized operators or service personnel, specific attack resistance is not required.

37.4 If complete records are remotely located in another room or building where they are intended to be accessible only to authorized operators or service personnel, specific attack resistance is not required.

38 Depository Tests

38.1 General

38.1.1 If a product also has a feature for receiving deposits, it shall comply with the requirements as specified in 38.2.1 – 38.3.3 as well as those of Sections 1– 32 and 39 – 41.

38.2 Depository container

38.2.1 The container of the product used for receiving and storing deposits shall comply with the same construction and performance requirements as the container used to protect the currency used for dispensing.

38.3 Depository mechanism

38.3.1 The mechanism of the product used to make deposits shall offer protection against removal or trapping of deposits that is equal to the protection against the removal or trapping of the currency used for dispensing. The mechanism is not acceptable if the attacker is able to remove three envelope deposits for an envelope depository, or one bag for a bag depository.

38.3.2 These requirements are specified in the Test of Customer Access Panel – 24-Hour Service, Section 34, or the Test of Business Hour Service Automated Teller System, Section 36, depending on the service of the product. Trapping is not a requirement of Section 36.

38.3.3 The test is to be conducted with the depository security container filled.

MANUFACTURING AND PRODUCTION TESTS FOR HIGH-VOLTAGE PRODUCTS

39 Production-Line Dielectric Voltage Withstand Test

39.1 The manufacturer shall conduct a dielectric voltage withstand test on each high-voltage product. A 40 – 70 Hz potential shall be applied between high-voltage live parts and dead metal parts for a period of 1 minute.

Exception: The time of application of the potential may be reduced to 1 second if the value of the test potential is 120 percent of the value shown:

- a) 1000 volts for units rated 250 volts or less and*
- b) 1000 volts plus twice rated voltage for units rated over 250 volts.*

39.2 For products using high-voltage and low-voltage circuits, the test is to be conducted with the low-voltage circuit connected to the cabinet, chassis, or other dead metal parts so that the potential which is applied between the high-voltage live parts and dead metal parts will simultaneously be applied between high-voltage live parts and low-voltage circuits.

39.3 Printed-wiring assemblies and other electronic-circuit components that would be affected adversely by application of the test potential or which would short circuit the test potential are to be removed, disconnected, or otherwise rendered inoperative before the dielectric withstand tests are made. A representative subassembly may be tested instead of an entire unit. Rectifier diodes in the power supply may be individually shunted before the test is made to avoid destroying them in the case of a fault elsewhere in the secondary circuits.

39.4 A 500 volt-ampere or larger transformer, the output voltage of which is essentially sinusoidal and can be varied, is to be used to determine compliance with 39.1. The requirement of a 500 volt-ampere or larger transformer can be waived if the high potential testing equipment used is such that it maintains the specified high potential voltage at the product for the duration of the test.

39.5 The test equipment used for the test as specified in 39.1 is to include a visible indication of application of the test potential and an audible indication, a visible indication of breakdown, or both. In the event of breakdown, manual reset of an external switch is to be required, or an automatic reject of the product under test is to result. Other arrangements may be used if found to achieve the results contemplated.

40 Production-Line Grounding Continuity Test

40.1 For cord-connected products the manufacturer shall test each product, or component of a product, to verify electrical continuity between the product and the grounding blade of the attachment plug cap.

40.2 For this test, the manufacturer is to use a resistance-indicating instrument determined to be acceptable, with leads and terminals by which the grounding circuit continuity may be determined.

40.3 Where the investigation of the product has shown all exposed dead-metal parts and all dead-metal parts within the enclosure which are exposed to contact during servicing to be adequately bonded to the frame and enclosure of the product, a test which determines the electrical continuity between the grounding blade and the frame or enclosure is sufficient.

MARKING

41 General

41.1 An automated teller system shall be legibly and permanently marked at a location that is visible after installation with the following information. The marking in (d) may be on a separate installation diagram referenced in the marking on the product.

- a) Manufacturer's or private labeler's name or identifying symbol;
- b) Model number or equivalent;
- c) Electrical rating, in volts, inputs in amperes or watts, and frequency. The ratings shall include the inputs at any accessory that may be supplied from the unit;
- d) Correct mounting position if a product is intended to be mounted in a definite position;
- e) Rating of the fuse in each fuseholder if required to comply with the requirements of this standard. The marking shall be located in close proximity to the fuseholder;
- f) Reference to an installation wiring diagram, if not attached to the product, by drawing number and issue date;

g) The security container's service rating:

- 1) Business Hour Service;
- 2) 24-Hour Service – Level 1;
- 3) 24-Hour Service – Level 2.

h) Date of manufacture by week, month, or quarter, and year, which may be abbreviated or written in an established or otherwise acceptable code. The date marking shall be such that it does not repeat itself in less than 20 years.

The rating marking specified in item (g) shall be located where it cannot be seen by the general public.

41.2 All markings shall be permanent. Markings affixed to a product shall be sufficiently durable as to resist the deleterious effects of handling, cleaning agents and similar actions expected in the intended use.

41.3 If a manufacturer produces automated teller systems at more than one factory, each product shall have a distinctive marking to identify it as the product of a particular factory.

41.4 If an automated teller system is for business hour service, it shall be additionally marked: "Intended Only For Use During Normal Business Hours," or the equivalent.

41.5 When a warning notice is required to be marked on a product, the letter height shall not be less than 7/64 inch (2.8 mm) for a signal word such as "DANGER," "WARNING," "CAUTION," or similar signal words, and not less than 3/32 inch (2.4 mm) for the remainder of the notice.

41.6 If the design of a product is such that replacing lamps or fuses or resetting circuit breakers exposes persons to accidental contact with normally enclosed live parts, the product shall be marked to indicate plainly that such servicing is to be performed only while the equipment is electrically disconnected from the branch-circuit supply. The marking shall be adjacent to every door or cover that requires opening.

41.7 There shall be legible and durable markings for each fuse used to meet the requirements in this standard indicating the ampere rating (and voltage rating if more than 125 volts) of the fuse to be used for replacement. The marking is to be located so that it is obvious to which fuse or fuseholder the marking applies. In addition, the following prominent marking shall be provided (a single marking may be used for a group of fuses) where it will be clearly visible to persons replacing fuses: "WARNING – For Continued Protection Against Fire Hazard, Replace Only With Same Type And Rating Of Fuse."

41.8 If a separate grounding conductor is necessary as part of the installation wiring for a product, a suitable marking shall be included on the product to indicate this fact. The marking shall make reference to the installation instructions unless complete instructions are attached to the appropriate unit.

41.9 If the wires in a terminal box or compartment of a product intended for power-supply connections may attain a temperature higher than 60°C (140°F) during the Temperature Test, Section 20, the unit shall be marked "For Supply Connections, Use Wires Suitable For At Least ___°C (___°F)," or with an equivalent statement at or near the point at which the supply connections are to be made. The marking shall be in a position in which it will be readily visible during and after installation of the unit. The temperature to be used in the marking shall be as indicated in the second column of Table 41.1.

Table 41.1
Temperature for marking

Temperature attained in terminal box or compartment,		Temperature in marking,	
°C	°F	°C	°F
61– 75	142 – 167	75	167
76 – 90	168 – 194	90	194

ACCESSORY EQUIPMENT

42 General

42.1 Accessory equipment shall comply with all applicable requirements as well as the requirements of 43.1 – 45.4.

42.2 For the purposes of these requirements, "accessory equipment" is defined as pieces of equipment designed to be attached or added to a unit of an automated teller system and of such size that they may be marked for identification by a suitable catalog number or its equivalent. Accessory equipment usually is dependent upon a basic unit of a system for mechanical and/or electrical support or input and may or may not, by itself, perform a complete function.

42.3 The term "accessory equipment" is not intended to cover individual items of circuitry or components that, for reasons of improving, modifying, or repairing the product, are added to the product subsequent to the time of initial assembly, and that lose their identity in the process.

43 Construction

43.1 Accessory equipment shall be designed and constructed so that it can be added to a unit of a product without creating a risk of electric shock, energy, casualty, or fire.

43.2 The installation of accessory equipment by an operator shall be restricted to an arrangement that can be accomplished mechanically by means of ordinary tools, for example, screwdrivers, pliers, adjustable wrenches, and similar tools, and electrically by means of plug-in connections to receptacles available on the basic product or as a part of the building wiring.

43.3 The installation of accessory equipment by qualified service personnel shall be such that the:

- a) Mechanical positioning can be accomplished by means of ordinary tools normally available, for example, screwdrivers, pliers, adjustable wrenches, or similar tools, or by means of special tools provided by the manufacturer as a part of the installation kit and
- b) Electrical connections can be readily accomplished by making use, wherever possible, of existing terminals and connections in the product.

43.4 The requirement in 43.3 does not preclude the addition, removal, or rerouting of insulated conductors to accomplish the desired change as long as the alterations in the wiring:

- a) Can be accomplished by the use of materials and reference to instructions and
- b) Do not require the use of makeshift or substitute parts not normally used in the basic construction of the product.

43.5 All wiring provided as part of an item of accessory equipment or related to its installation shall be rated for use at the highest voltage and temperature that can be encountered in the area in which the wire is to be installed.

44 Performance (Installation) Test

44.1 Each piece of accessory equipment shall be installed in its intended manner on the product for which it is designed by following the instructions provided. See 45.3 and 45.4.

44.2 Particular attention is to be paid to the mechanical mounting arrangements and types of plugs provided with operator-installed accessory equipment to determine that the equipment can be properly positioned and that the plug-in connections cannot be inadvertently interchanged in a manner that introduces a hazard.

44.3 With the item of accessory equipment installed and operating, the basic unit of the product shall be subjected to each of the tests set forth in the preceding sections of this standard that are considered necessary in determining that the performance of the product is not altered so as to not comply with the requirements of this standard.

45 Marking

45.1 Each item of accessory equipment shall be marked with the manufacturer's or private labeler's name and a distinctive catalog number or equivalent identification.

45.2 If the accessory equipment is supplied with power from a separate branch-circuit source of supply, it shall be marked with an input rating and related information as required under Marking, General, Section 41.

45.3 Accessory equipment intended to be installed by an operator shall be marked to indicate the product for which it is intended and shall include instructions on the equipment that will provide sufficient information to enable the accessory equipment to be mounted on and interconnected with the basic product.

45.4 Accessory equipment intended to be installed by qualified personnel shall have instructions for each item for accessory equipment that provide a step-by-step outline of the mechanical and electrical alterations that can be accomplished to ensure intended installation and operation. The instructions may be provided either on or packed with each item of accessory equipment or may be included in the service manual.

APPENDIX A

Standards for Components

Standards under which components of the products covered by this standard are evaluated include the following:

Title of Standard – UL Standard Designation

Attachment Plugs and Receptacles – UL 498

Audio/Video and Musical Instrument Apparatus for Household, Commercial, and Similar General Use – UL 6500

Ballasts, Fluorescent-Lamp – UL 935

Capacitors – UL 810

Circuit-Breakers, Molded-Case, Molded-Case Switches, and Circuit-Breaker Enclosures – UL 489

Cord Sets and Power-Supply Cords – UL 817

Controls for Household and Similar Use, Part 1: General Requirements, Automatic Electrical – UL 60730-1

Fittings for Cable and Conduit – UL 514B

Flexible Cord and Fixture Wire – UL 62

Fuseholders – UL 512

Lampholders, Edison-Base – UL 496

Lampholders, Starters, and Starter Holders for Fluorescent Lamps – UL 542

Locks, Combination – UL 768

Locks, Key – UL 437

Marking and Labeling Systems – UL 969

Motors, Electric – UL 1004

Motors, Overheating Protection for – UL 2111

Outlet Boxes, Flush-Device Boxes, and Covers, Nonmetallic – UL 514C

Outlet Boxes, Metallic, – UL 514

Plastic Materials for Parts in Devices and Appliances, Tests for Flammability of – UL 94

Polymeric Materials – Fabricated Parts – UL 746D

Polymeric Materials – Industrial Laminates, Filament Wound Tubing, Vulcanized Fibre, and Materials Used in Printed-Wiring Boards – UL 746E

Polymeric Materials – Long Term Property Evaluations – UL 746B

Polymeric Materials – Short Term Property Evaluations – UL 746A

Polymeric Materials – Use in Electrical Equipment Evaluations – UL 746C

Printed-Wiring Boards – UL 796

Radio Receivers, Audio Systems, and Accessories – UL 1270

Switches, General-Use Snap – UL 20

Switches, Special-Use – UL 1054

Tape, Polyvinyl Chloride, Polyethylene, and Rubber Insulating – UL 510

Temperature-Indicating and -Regulating Equipment – UL 873

Temperature Sensing Controls, Automatic Electrical Controls for Household and Similar Use; Part 2: Particular Requirements for – UL 60730-2-9

Terminal Blocks – UL 1059

Terminals, Electrical Quick-Connect – UL 310

Thermal Cutoffs for Use in Electrical Appliances and Components – UL 1020

Timelocks, Delayed-Action – UL 887

Tubing, Extruded Insulating – UL 224

Wire Connectors and Soldering Lugs for Use with Copper Conductors – UL 486A

Wires and Cables, Thermoplastic-Insulated – UL 83
Wires and Cables, Thermoset-Insulated – UL 44