

# Household and similar electrical appliances — Safety —

## Part 2-9: Particular requirements for grills, toasters and similar portable cooking appliances

The European Standard EN 60335-2-9:2003, with the incorporation of amendment A1:2004, has the status of a British Standard

ICS 13.120; 97.040.50

## National foreword

This British Standard is the official English language version of EN 60335-2-9:2003, including amendment A1:2004. It was derived by CENELEC from IEC 60335-2-9:2002, including amendment 1:2004. It supersedes BS EN 60335-2-9:1996 which will be withdrawn on 2006-03-01.

The CENELEC common modifications have been implemented at the appropriate places in the text and are indicated by tags **[C]** **[C]**.

The start and finish of text introduced or altered by amendment is indicated in the text by tags **[A1]** **[A1]**. Tags indicating changes to IEC text carry the number of the IEC amendment. For example, text altered by IEC amendment 1 is indicated by **[A1]** **[A1]**.

The UK participation in its preparation was entrusted by Technical Committee CPL/61, Safety of household electrical appliances, to Subcommittee CPL/61/07, Heated appliances group, which has the responsibility to:

- aid enquirers to understand the text;
- present to the responsible European committee any enquiries on the interpretation, or proposals for change, and keep the UK interests informed;
- monitor related international and European developments and promulgate them in the UK.

A list of organizations represented on this subcommittee can be obtained on request to its secretary.

### Cross-references

The British Standards which implement international or European publications referred to in this document may be found in the *BSI Catalogue* under the section entitled “International Standards Correspondence Index”, or by using the “Search” facility of the *BSI Electronic Catalogue* or of British Standards Online.

This publication does not purport to include all the necessary provisions of a contract. Users are responsible for its correct application.

**Compliance with a British Standard does not of itself confer immunity from legal obligations.**

### Summary of pages

This document comprises a front cover, an inside front cover, the EN title page, pages 2 to 30, an inside back cover and a back cover.

The BSI copyright notice displayed in this document indicates when the document was last issued.

### Amendments issued since publication

Amd. No.	Date	Comments
15203	8 July 2004	See national foreword

This British Standard was published under the authority of the Standards Policy and Strategy Committee on 9 September 2003

© BSI 8 July 2004

ISBN 0 580 42558 4

EUROPEAN STANDARD

NORME EUROPÉENNE

EUROPÄISCHE NORM

**EN 60335-2-9**

August 2003

**+ A1**

May 2004

ICS 13.120; 97.040.50

Supersedes EN 60335-2-9:1995 + A1:1998 + A2:2000 + A11:2000 + A12:2002 + A13:2002

English version

**Household and similar electrical appliances –  
Safety**  
**Part 2-9: Particular requirements for grills, toasters  
and similar portable cooking appliances**  
(including amendment A1:2004)  
(IEC 60335-2-9:2002, modified + A1:2004)

Appareils électrodomestiques et analogues –  
Sécurité

Partie 2-9: Règles particulières  
pour les grils, grille-pain et  
appareils de cuisson mobiles analogues  
(inclut l'amendement A1:2004)  
(CEI 60335-2-9:2002, modifiée + A1:2004)

Sicherheit elektrischer Geräte für den  
Hausgebrauch und ähnliche Zwecke

Teil 2-9: Besondere Anforderungen  
für Grillgeräte, Brotröster und  
ähnliche ortsveränderliche Kochgeräte  
(enthält Änderung A1:2004)  
(IEC 60335-2-9:2002, modifiziert + A1:2004)

This European Standard was approved by CENELEC on 2003-03-01; amendment A1 was approved by CENELEC on 2004-03-01. CENELEC members are bound to comply with the CEN/CENELEC Internal Regulations which stipulate the conditions for giving this European Standard the status of a national standard without any alteration.

Up-to-date lists and bibliographical references concerning such national standards may be obtained on application to the Central Secretariat or to any CENELEC member.

This European Standard exists in three official versions (English, French, German). A version in any other language made by translation under the responsibility of a CENELEC member into its own language and notified to the Central Secretariat has the same status as the official versions.

CENELEC members are the national electrotechnical committees of Austria, Belgium, Cyprus, Czech Republic, Denmark, Estonia, Finland, France, Germany, Greece, Hungary, Iceland, Ireland, Italy, Latvia, Lithuania, Luxembourg, Malta, Netherlands, Norway, Poland, Portugal, Slovakia, Slovenia, Spain, Sweden, Switzerland and United Kingdom.

**CENELEC**

European Committee for Electrotechnical Standardization  
Comité Européen de Normalisation Electrotechnique  
Europäisches Komitee für Elektrotechnische Normung

**Central Secretariat: rue de Stassart 35, B - 1050 Brussels**

## Foreword

The text of document 61/2100/FDIS, future fifth edition of IEC 60335-2-9, prepared by the IEC Technical Committee 61, was submitted to the IEC-CENELEC parallel vote.

A proposal for an amendment, document CLC/TC 61(SEC)1371, was discussed during the Kista meeting of CENELEC TC 61 in May 2002, when it was decided to submit a draft amendment prA11 to the formal vote. As a result of the Kista meeting, a draft amendment prAA containing the relevant existing common modifications was also submitted to the formal vote.

The texts of the FDIS, prA11 and prAA were approved by CENELEC as a new edition of EN 60335-2-9 on 2003-03-01.

This European Standard replaces EN 60335-2-9:1995 + A1:1998 + A2:2000 + A11:2000 + A12:2002 + A13:2002.

The following dates are applicable:

- latest date by which the EN has to be implemented  
at national level by publication of an identical  
national standard or by endorsement (dop) 2004-03-01
- date on which national standards  
conflicting with the EN have to be withdrawn (dow) 2006-03-01

This part 2 has to be used in conjunction with EN 60335-1, Household and similar electrical appliances – Safety – Part 1: General requirements. It was established on the basis of the 2002 edition of that standard. Amendments and revisions of Part 1 have also to be taken into account and the dates when such changes become applicable will be stated in the relevant amendment or revision of Part 1.

This part 2 supplements or modifies the corresponding clauses of EN 60335-1, so as to convert it into the European Standard: Safety requirements for electric grills, toasters and similar portable cooking appliances.

When a particular subclause of Part 1 is not mentioned in this part 2, that subclause applies as far as is reasonable. When this standard states "addition", "modification" or "replacement", the relevant text of Part 1 is to be adapted accordingly.

NOTE 1 The following numbering system is used:

- subclauses, tables and figures that are numbered starting from 101 are additional to those in Part 1;
- unless notes are in a new subclause or involve notes in Part 1, they are numbered starting from 101, including those in a replaced clause or subclause;
- additional annexes are lettered AA, BB, etc.;
- subclauses, notes and annexes that are additional to those in the IEC standard are prefixed with the letter Z.

NOTE 2 The following print types are used:

- requirements: in roman type;
- *test specifications: in italic type;*
- notes: in small roman type.

Words in **bold** in the text are defined in Clause 3. When a definition concerns an adjective, the adjective and the associated noun are also in bold.

There are no special national conditions causing a deviation from this European Standard, other than those listed in Annex ZA to EN 60335-1.

There are no national deviations from this European Standard, other than those listed in Annex ZB to EN 60335-1.

p NOTE In this document, p is used in the margin to indicate instructions for preparing the printed version.

## Introduction

An investigation by CENELEC TC 61 has shown that all risks from products within the scope of this standard are fully covered by the Low Voltage Directive, 73/23/EEC. For products having mechanical moving parts, a risk assessment in accordance with the Machinery Directive, 98/37/EC, has shown that the risks are mainly of electrical origin and consequently this directive is not applicable. However, the relevant essential safety requirements of the Machinery Directive are covered by this standard together with the principal objectives of the Low Voltage Directive.

---

## Endorsement notice

The text of the International Standard IEC 60335-2-9:2002 was approved by CENELEC as a European Standard with agreed common modifications .

## Foreword to amendment A1

The text of document 61/2535/FDIS, future amendment 1 to IEC 60335-2-9:2002, prepared by the IEC Technical Committee 61, Safety of household and similar electrical appliances, was submitted to the IEC-CENELEC parallel vote and was approved by CENELEC as amendment A1 to EN 60335-2-9:2003 on 2004-03-01.

The following dates are applicable:

- latest date by which the amendment has to be implemented at national level by publication of an identical national standard or by endorsement (dop) 2004-12-01
- date on which national standards conflicting with the amendment have to be withdrawn (dow) 2007-03-01

This amendment supplements or modifies the corresponding clauses of EN 60335-2-9:2003.

There are no special national conditions causing a deviation from this amendment.

There are no national deviations from this amendment.

p NOTE In this document, p is used in the margin to indicate instructions for preparing the printed version.

---

## Endorsement notice

The text of amendment 1:2004 to the International Standard IEC 60335-2-9:2002 was approved by CENELEC as an amendment to the European Standard without any modification.

## CONTENTS

INTRODUCTION.....	5
1 Scope.....	6
2 Normative references .....	7
3 Definitions .....	7
4 General requirement.....	10
5 General conditions for the tests .....	10
6 Classification.....	11
7 Marking and instructions.....	11
8 Protection against access to live parts.....	13
9 Starting of motor-operated appliances .....	13
10 Power input and current .....	13
11 Heating .....	14
12 Void .....	15
13 Leakage current and electric strength at operating temperature.....	15
14 Transient overvoltages .....	16
15 Moisture resistance .....	16
16 Leakage current and electric strength.....	17
17 Overload protection of transformers and associated circuits .....	17
18 Endurance.....	17
19 Abnormal operation .....	17
20 Stability and mechanical hazards .....	19
21 Mechanical strength .....	20
22 Construction .....	20
23 Internal wiring.....	22
24 Components .....	23
25 Supply connection and external flexible cords .....	24
26 Terminals for external conductors.....	24
27 Provision for earthing .....	24
28 Screws and connections.....	24
29 Clearances, creepage distances and solid insulation .....	24
30 Resistance to heat and fire.....	24
31 Resistance to rusting.....	25
32 Radiation, toxicity and similar hazards.....	25
Annexes .....	29
Bibliography.....	30
Figure 101 – Examples of appliances.....	26
Figure 102 – Load for testing rotating spits .....	27
Figure 103 – Vessel for testing hotplates .....	28
Figure 104 – Vessel for testing induction hotplates .....	28
Table 101 – Quantity of liquid in the vessel.....	8

## INTRODUCTION

It has been assumed in the drafting of this International Standard that the execution of its provisions is entrusted to appropriately qualified and experienced persons.

This standard recognizes the internationally accepted level of protection against hazards such as electrical, mechanical, thermal, fire and radiation of appliances when operated as in normal use taking into account the manufacturer's instructions. <sup>(A1)</sup> It also covers abnormal situations that can be expected in practice and takes into account the way in which electromagnetic phenomena can affect the safe operation of appliances. <sup>(A1)</sup>

This standard takes into account the requirements of IEC 60364 as far as possible so that there is compatibility with the wiring rules when the appliance is connected to the supply mains. However, national wiring rules may differ.

If an appliance within the scope of this standard also incorporates functions that are covered by another part 2 of IEC 60335, the relevant part 2 is applied to each function separately, as far as is reasonable. If applicable, the influence of one function on the other is taken into account.

This standard is a product family standard dealing with the safety of appliances and takes precedence over horizontal and generic standards covering the same subject.

An appliance that complies with the text of this standard will not necessarily be considered to comply with the safety principles of the standard if, when examined and tested, it is found to have other features which impair the level of safety covered by these requirements.

An appliance employing materials or having forms of construction differing from those detailed in the requirements of this standard may be examined and tested according to the intent of the requirements and, if found to be substantially equivalent, may be considered to comply with the standard.

## HOUSEHOLD AND SIMILAR ELECTRICAL APPLIANCES – SAFETY –

### Part 2-9: Particular requirements for grills, toasters and similar portable cooking appliances

#### 1 Scope

This clause of Part 1 is replaced by the following.

This International Standard deals with the safety of electric **portable appliances** for household purposes that have a cooking function such as baking, roasting and grilling, their **rated voltage** being not more than 250 V.

NOTE 101 Examples of appliances that are within the scope of this standard are

- barbecues for indoor use;
- **breadmakers**; **breadmakers**;
- **contact grills** (griddles);
- **cookers**;
- **food dehydrators**;
- **hotplates**;
- **portable ovens**;
- **raclette grills**;
- **radiant grills**;
- **roasters**;
- **rotary grills**;
- rotisseries;
- **toasters**;
- **waffle irons**;

Examples are illustrated in Figure 101.

As far as is practicable, this standard deals with the common hazards presented by appliances that are encountered by all persons in and around the home. However, in general, it does not take into account

- the use of appliances by young children or infirm persons without supervision;
- playing with the appliance by young children.

NOTE 102 Attention is drawn to the fact that

- for appliances intended to be used in vehicles or on board ships or aircraft, additional requirements may be necessary;
- in many countries additional requirements are specified by the national health authorities, the national authorities responsible for the protection of labour and similar authorities.

NOTE 103 This standard does not apply to

- **stationary ovens** and **stationary grills** (IEC 60335-2-6);
- warming plates (IEC 60335-2-12);
- frying pans and deep fat fryers (IEC 60335-2-13);
- microwave ovens (IEC 60335-2-25);
- barbecues for outdoor use (IEC 60335-2-78);
- appliances intended for commercial catering;
- appliances intended to be used in locations where special conditions prevail, such as the presence of a corrosive or explosive atmosphere (dust, vapour or gas).



## 2 Normative references

**A1**) This clause of Part 1 is applicable except as follows.

*Addition:*

IEC 60068-2-52, *Environmental testing — Part 2: Tests — Test Kb: Salt mist, cyclic (sodium chloride solution)* **A1**

## 3 Definitions

This clause of Part 1 is applicable except as follows.

### 3.1.9 Replacement:

#### normal operation

**A1**) Operation of the appliance as specified in the following subclauses. **A1**

NOTE 101 Appliances not mentioned but which nevertheless perform one of the functions are operated as specified for this function as far as possible.

**3.1.9.101 Toasters** are loaded with the maximum number of slices of white bread specified in the instructions and operated in cycles, each cycle consisting of an operating period and a rest period. The bread is approximately 24 h old and the dimensions of the slices are approximately 100 mm × 100 mm × 10 mm. The rest periods have a duration of 30 s or the minimum period needed for the resetting of a control, whichever is longer. The slices of bread are replaced during each rest period. The operating period is established by adjusting controls to give the bread a golden-brown colour. For toasters without a control, each operating period is terminated as soon as the colour of the bread turns golden-brown.

**Toasters** incorporating a device for heating rolls are loaded with the maximum number of rolls specified in the instructions. The **toaster** is operated in cycles, each cycle consisting of an operating period followed by a rest period of 30 s when the rolls are turned or replaced. The control is adjusted in accordance with the instructions. If instructions are not given, the control is adjusted for the toasting operation.

**Sandwich-toasting attachments** are loaded with one or more sandwiches that are positioned in accordance with the instructions to produce the most unfavourable result. Each sandwich comprises two slices of white bread filled with a single slice of suitable cheese having an area equal to a slice of bread and a thickness of approximately 5 mm. The toaster is then operated in accordance with the instructions in cycles, each cycle consisting of a toasting operation followed by a rest period of 30 s, or the minimum period needed for the resetting of a control, whichever is longer.

NOTE Processed cheese and other cheeses that readily melt when heated are suitable.

**3.1.9.102 Rotary grills** are operated with the load on the rotating spit shown in Figure 102.

**3.1.9.103 Waffle irons** having a **thermostat** are operated with the **thermostat** adjusted to the highest setting. Other **waffle irons** are operated so that the temperature at the centre of the heated surface is maintained at 210 °C ± 15 °C by switching the supply on and off.

**3.1.9.104 Ovens** are operated with the door closed. **Ovens** having a **thermostat** are operated so that the mean temperature in the centre of the cavity is maintained at 240 °C ± 4 °C or at the value obtained with the **thermostat** adjusted to its highest setting, if this results in a lower temperature. Other **ovens** are operated so that the temperature in the centre of the cavity is maintained at 240 °C ± 15 °C by switching the supply on and off.

**3.1.9.105 Roasters** are operated with the lid closed. The mean temperature in the centre of the container is maintained at 240 °C ± 4 °C, if necessary by switching the supply on and off.

**3.1.9.106 Radiant grills, rotary grills and raclette appliances** are operated with the controls adjusted in accordance with the instructions, or if instructions are not provided with the controls adjusted to the highest setting. Doors or lids are open unless otherwise specified in the instructions.

**Contact grills** having a **thermostat** are operated with the **thermostat** adjusted to the highest setting. Other **contact grills** are operated so that the temperature at the centre of the heated surface is maintained at  $275\text{ °C} \pm 15\text{ °C}$  by switching the supply on and off.

**Raclette grills** are operated with doors or lids open, unless otherwise specified in the instructions. Controls are adjusted in accordance with the instructions, pans being in position or removed, whichever is more unfavourable.

**3.1.9.107 Barbecues** are operated with food supports in the lowest position. Controls are adjusted to the highest setting, any covers or shields being positioned in accordance with the instructions.

NOTE **Barbecues** are operated without water even if the use of water is recommended.

**3.1.9.108 Hotplates**, other than **induction hotplates**, are operated with vessels containing water. The vessels are made of unpolished commercial quality aluminium, have a flat bottom and are covered with a lid. A suitable vessel is specified in Figure 103. Controls are adjusted to their highest setting until the water boils and then adjusted so that the water simmers. Water is added to maintain the level during boiling.

NOTE 1 The lid is positioned so that steam does not affect the test.

**Induction hotplates** are operated with vessels, as specified in Figure 104, containing cooking oil. Controls are adjusted to their highest setting until the oil temperature reaches  $180\text{ °C} \pm 4\text{ °C}$  and are then adjusted so that this temperature is maintained. The oil temperature is measured 1 cm above the centre of the bottom of the vessel.

For all **hotplates**, the diameter of the bottom of the vessel is approximately equal to the diameter of the **cooking zone** and the quantity of liquid is specified in Table 101. The vessel is positioned centrally on the **cooking zone**.

**Table 101 – Quantity of liquid in the vessel**

Diameter of cooking zone mm	Quantity of water or oil l
$\leq 110$	0,6
$>110$ and $\leq 145$	1,0
$>145$ and $\leq 180$	1,5
$>180$ and $\leq 220$	2,0
$>220$ and $\leq 300$	3,0

NOTE 2 If several **cooking zones** are marked for one **hotplate**, the most unfavourable zone is used for the test.

NOTE 3 For non-circular **cooking zones**, the smallest non-circular vessel is used that will cover the **cooking zone** as far as possible, taking into account the **hob** rim and other vessels. The quantity of liquid is determined on the basis of the minor diameter of the **cooking zone**.

**3.1.9.109 Raclette appliances** are operated with the controls adjusted in accordance with the instructions, or if instructions are not provided, with the controls adjusted to the highest setting.

**3.1.9.110 Food dehydrators** are operated empty.

**3.1.9.111 Breadmakers** are operated using the most unfavourable cycle and ingredients specified in the instructions.

NOTE The most unfavourable cycle may be for a function such as jam-making that allows the heating element and the kneading motor to operate simultaneously. **A1**

**3.101  
toaster**

appliance intended for toasting slices of bread by radiant heat

**3.102  
waffle iron**

appliance having two heated hinged plates that are shaped to contain batter

**3.103  
oven**

appliance having a heated cavity with a door and constructed so that food that may be in a container can be placed on a shelf

**3.104  
roaster**

appliance having a heated container with a lid and constructed so that food can be placed in it

**3.105  
rotary grill**

appliance having a **visible glowing heating element** and a rotating spit to support the food

NOTE A **rotary grill** is also known as a rotisserie.

**3.106  
radiant grill**

appliance having a **visible glowing heating element** and a support on which food can be placed

NOTE A **radiant grill** may be placed in a compartment with or without a door.

**3.107  
contact grill**

appliance having a heated surface on which food is placed. It may have a second heated surface to cover the food

NOTE A **contact grill** with only one heated surface is known as a griddle.

**3.108  
sandwich-toasting attachment**

accessory for use with a **toaster** for toasting sandwiches

**3.109  
raclette grill**

appliance for melting slices of cheese placed in small pans positioned under the heating element

NOTE **Raclette grills** may have a surface that is used as a griddle.

**3.110  
raclette appliance**

**radiant grill** for melting the surface of a large piece of cheese

**3.111  
barbecue**

**radiant grill** having a heating element located under the food support

**3.112****hotplate**

appliance having one or more **heating units** on which vessels can be placed for cooking purposes

NOTE **Hotplates** do not incorporate an **oven** or grill.

**3.113****induction hotplate**

**hotplate** that can heat at least one metallic vessel by means of eddy currents

NOTE The eddy currents are induced in the bottom of the vessel by the electromagnetic field of a coil.

**3.114****cooker**

appliance incorporating a **hotplate** and an **oven**

NOTE **Cookers** may incorporate a grill.

**3.115****food dehydrator**

appliance for dehydrating food by means of heated air

NOTE The appliance may incorporate a fan.

**3.116****heating unit**

part of the appliance that fulfils an independent cooking or warming function

**3.117****cooking zone**

area marked on a **hotplate** where the vessel is placed for heating food

**3.118****touch control**

control actuated by contact or proximity of a finger, with little or no movement of the contact surface

**A<sub>1</sub> 3.119****breadmaker**

appliance intended for making bread comprising a heated compartment incorporating dough kneading facilities A<sub>1</sub>

**4 General requirement**

This clause of Part 1 is applicable.

**5 General conditions for the tests**

This clause of Part 1 is applicable except as follows.

**5.2 Addition:**

NOTE 101 If the test of 15.101 has to be carried out, three additional samples are required.

**5.3 Addition:**

*If it is evident from the construction of the appliance that the test of one function will produce more favourable results than another, this function is not tested.*

**5.6 Addition:**

If two or more cooking functions can be performed simultaneously, they are tested at the same time.

**5.101 Induction hotplates** are operated as specified for **motor-operated appliances**. Other appliances are tested as specified for **heating appliances**, even if they incorporate motors.

**6 Classification**

**A1** This clause of Part 1 is applicable except as follows.

**6.2 Addition:**

Appliances intended for outdoor use shall be at least IPX4. **A1**

**7 Marking and instructions**

This clause of Part 1 is applicable except as follows.

**7.1 Addition:**

The **rated power input** or **rated current** of **induction hotplates** shall also be marked.

Appliances intended to be partially immersed in water for cleaning shall be marked with the maximum level of immersion and the substance of the following:

Do not immerse beyond this level.

**C** **Cookers, portable ovens and rotary grills** shall be marked with symbol 5041 of IEC 60417-1 or with the substance of the following:

CAUTION: Hot surface.

NOTE Z101 Symbol 5041 of IEC 60417-1 is a warning sign and the rules of ISO 3864 apply. However the colours may vary to ensure legibility. **C**

**C 7.6 Addition:**

[symbol 5041 of IEC 60417-1]

Caution, hot surface **C**

**7.12 Addition:**

The instructions for appliances incorporating an appliance inlet, and intended to be partially or fully immersed in water for cleaning, shall state that the connector must be removed before the appliance is cleaned and that the appliance inlet must be dried before the appliance is used again.

The instructions for appliances intended to be used with a connector incorporating a **thermostat** shall state that only the appropriate connector must be used.

Ⓐ) The instructions for appliances intended for outdoor use shall include the substance of the following:

- the appliance is suitable for outdoor use;
- the supply cord should be regularly examined for signs of damage, and if the cord is damaged, the appliance must not be used;
- the appliance must be supplied through a residual current device (RCD) having a rated residual operating current not exceeding 30 mA;
- the appliance is to be connected to a socket-outlet having an earthing contact (for **class I appliances**). Ⓐ)

Ⓒ) The instructions for appliances having **accessible metal surfaces**, other than working surfaces, that have a temperature rise exceeding 90 K during the test of Clause 11 shall include the substance of the following:

The temperature of accessible surfaces may be high when the appliance is operating. Ⓒ)

The door or the outer surface may get hot when the appliance is operating.

The instructions for **toasters** shall include the substance of the following:

The bread may burn, therefore do not use the **toaster** near or below combustible material, such as curtains.

The instructions for **barbecues** shall include the substance of the following:

WARNING: Charcoal or similar combustible fuels must not be used with this appliance.

The instructions for **barbecues** intended to be used with water shall state the maximum quantity of water to be poured into the appliance.

The instructions for **hotplates** having surfaces of glass-ceramic or similar material protecting **live parts** shall include the substance of the following:

WARNING: If the surface is cracked, switch off the appliance to avoid the possibility of electric shock.

The instructions for **induction hotplates** shall include the substance of the following:

Metallic objects such as knives, forks, spoons and lids should not be placed on the hotplate since they can get hot.

Ⓒ) The instructions shall include details on how to clean surfaces in contact with food. For **toasters**, they shall include details on how to remove breadcrumbs, when applicable.

If symbol 5041 of IEC 60417-1 is marked on the appliance, the instructions shall state that the surfaces are liable to get hot during use.

Ⓐ) The instructions for **breadmakers** shall state the maximum quantities of flour and raising agent that may be used. Ⓐ)

#### 7.14 Addition:

The height of the triangle used with symbol 5041 of IEC 60417-1 shall be at least 12 mm. Ⓒ)

## 8 Protection against access to live parts

This clause of Part 1 is applicable except as follows.

### 8.1.1 Addition:

*For **toasters** having a crumb tray, the test finger is not applied through the crumb-tray opening to **live parts** that are disconnected by the operation of a double pole switch. However, it shall not be possible to touch these parts with test probe 41 of IEC 61032.*

## 9 Starting of motor-operated appliances

This clause of Part 1 is not applicable.

## 10 Power input and current

This clause of Part 1 is applicable except as follows.

### 10.1 Addition:

*The power input of **induction hotplates** is measured separately.*

### 10.2 Addition:

*The current of **induction hotplates** is measured separately.*

## 11 Heating

This clause of Part 1 is applicable except as follows.

### 11.1 Addition:

Compliance for **toasters** is also checked by the test of 11.Z101.

**11.Z101 Toasters** in which the bread is inserted through the top are operated at **rated power input**. They are operated for three cycles under **normal operation**.

The temperature rise of **accessible surfaces** of metallic sides that are at a height lower than 25 mm below the top surface shall not exceed 90 K.

NOTE There are no temperature rise limits specified for other surfaces. C

### 11.2 Addition:

**Radiant grills** and **raclette grills** that are loaded from the front, **rotary grills**, **ovens**, A<sub>1</sub> **breadmakers**, **cookers** and **hotplates** A<sub>1</sub> are placed with their backs as near as possible to one of the walls of the test corner and away from the other wall. Other appliances are placed away from the walls.

### 11.3 Addition:

NOTE 101 If the magnetic field of an **induction hotplate** unduly influences the results, the temperature rises can be determined using platinum resistances with twisted connecting wires or any equivalent means.

### 11.4 Addition:

If the temperature rise limits are exceeded in appliances incorporating motors, transformers or **electronic circuits**, and the power input is lower than the **rated power input**, the test is repeated with the appliance supplied at 1,06 times **rated voltage**.

### 11.7 Replacement:

A<sub>1</sub> **Breadmakers** are operated for one cycle. A<sub>1</sub>

**Toasters** are operated for 15 min. Unless they are constructed to toast only one slice of bread, they are tested for a further 5 min with one slice of bread inserted in the most unfavourable position.

**Toasters** incorporating a device for heating rolls are operated for five cycles.

**Toasters** having **sandwich-toasting attachments** are also tested for five cycles of operation. They are also tested for one cycle of operation with the sandwich in the most unfavourable position.

**Radiant grills** are operated for a period of 30 min, for the maximum period indicated in the instructions or for the maximum period allowed by a timer, whichever is the longer.

**Ovens**, **roasters** and **rotary grills** are operated until steady conditions are established but for not longer than 60 min. However, if a **rotary grill** has a timer, the timer is reset as many times as necessary to establish steady conditions.

**Contact grills** having **thermostats** are operated until steady conditions are established. Other **contact grills** are operated for 30 min after the centre of the heating surface attains a temperature of 275 °C.

**Waffle irons** are operated until steady conditions are established but for not longer than 30 min after the centre of the heating surface attains a temperature of 210 °C.



**Raclette grills, barbecues and food dehydrators** are operated until steady conditions are established.

**Induction hotplates** are operated for 30 min. Other **hotplates** are operated for 60 min.

For **cookers**, combinations of **heating units** that can be energised simultaneously are tested together, the **heating units** being switched on for the duration specified.

NOTE 101 If the appliance is subjected to more than one test, it is cooled to room temperature before each test.

#### 11.8 Modification:

For **radiant grills, rotary grills, raclette grills, hotplates and cookers**, instead of 65 K, the temperature rise of the wall of the test corner shall not exceed 75 K.

#### Addition:

When an appliance connector incorporates a **thermostat**, the temperature rise limit for the pins of the appliance inlet does not apply.

The temperature rise limits of motors, transformers and components of **electronic circuits**, including parts directly influenced by them, may be exceeded when the appliance is operated at 1,15 times **rated power input**.

Cheese used in **sandwich toasting attachments** shall not flow into places where it could give rise to a hazard, such as reducing **clearances** or **creepage distances** below the values specified in Clause 29.

## 12 Void

## 13 Leakage current and electric strength at operating temperature

This clause of Part 1 is applicable except as follows.

### 13.1 Addition:

If a grill is incorporated in an **oven**, either the **oven** or the grill is operated, whichever is more unfavourable.

### 13.2 Addition:

If there is earthed metal between **live parts** and the surface of glass-ceramic or similar material of **hotplates**, the leakage current is measured between **live parts** and each vessel in turn connected to the earthed metal. It shall not exceed 0,75 mA. If there is no earthed metal, the leakage current, measured between **live parts** and each of the vessels in turn, shall not exceed 0,25 mA.

### 13.3 Addition:

If there is earthed metal between **live parts** and the surface of glass-ceramic or similar material of **hotplates**, a test voltage of 1 000 V is applied between **live parts** and all the vessels connected to the earthed metal. If there is no earthed metal, a test voltage of 3 000 V is applied between **live parts** and the vessels.

## 14 Transient overvoltages

This clause of Part 1 is applicable.

## 15 Moisture resistance

This clause of Part 1 is applicable except as follows.

### 15.2 Addition:

*For ovens, 0,5 l of water containing approximately 1 % NaCl is poured uniformly over the bottom surface of the oven.*

*Hotplates and cookers are positioned so that the top surface is horizontal. A vessel having the largest diameter shown in Figure 103, which does not exceed the diameter of the **cooking zone**, is completely filled with water containing approximately 1 % NaCl and positioned centrally over the **cooking zone**. A further quantity of approximately 0,5 l of the solution is poured steadily into the vessel over a period of 15 s. The test is carried out on each **cooking zone** in turn, after removing any residual solution from the appliance.*

*If the heating element of a **hotplate** incorporates a thermal control, 0,02 l of the saline solution is poured over the **cooking zone** so that it flows over the control. A vessel is then placed on the **cooking zone** to depress any movable part.*

*For **hotplates** having ventilating openings in the heated surface, 0,2 l of the saline solution is poured steadily through the funnel onto the ventilating openings. The funnel has an outlet diameter of 8 mm and is positioned vertically with the outlet 200 mm above the heated surface. The funnel is positioned above the ventilating openings so that the solution enters the appliance in the most unfavourable way.*

NOTE 101 If the opening is protected, the funnel is positioned so that the solution falls onto the heated surface as close as possible to the opening.

*For other appliances with heating elements that are covered by vessels in normal use, the spillage test is carried out by steadily pouring saline solution onto the heating surface over a period of 1 min, 0,1 l of solution being used for every 100 cm<sup>2</sup> of the heating surface.*

*The spillage test is not carried out on **roasters**.*

**15.101** Appliances intended to be partially or completely immersed in water for cleaning shall have adequate protection against the effects of immersion.

*Compliance is checked by the following tests, which are carried out on three additional appliances.*

*The appliances are operated under **normal operation** at 1,15 times **rated power input**, until the **thermostat** operates for the first time. Appliances without a **thermostat** are operated until steady conditions are established. The appliances are disconnected from the supply, any appliance connector being withdrawn. They are then completely immersed in water containing approximately 1 % NaCl and having a temperature between 10 °C and 25 °C, unless they are marked with the maximum level of immersion, in which case they are immersed 5 cm deeper than this level.*

*After 1 h, the appliances are removed from the saline solution, dried and subjected to the leakage current test of 16.2.*

NOTE Care is to be taken to ensure that all moisture is removed from the insulation around the pins of appliance inlets.

*This test is carried out four more times, after which the appliances shall withstand the electric strength test of 16.3, the voltage being as specified in Table 4.*

*The appliance having the highest leakage current after the fifth immersion is dismantled and inspection shall show that there is no trace of liquid on insulation that could result in a reduction of **clearances** and **creepage distances** below the values specified in Clause 29.*

*The remaining two appliances are operated under **normal operation** for 240 h at 1,15 times **rated power input**. After this period, the appliances are disconnected from the supply and immersed again for 1 h. They are then dried and subjected to the electric strength test of 16.3, the voltage being as specified in Table 4.*

*Inspection shall show that there is no trace of liquid on insulation that could result in a reduction of **clearances** and **creepage distances** below the values specified in Clause 29.*

## 16 Leakage current and electric strength

This clause of Part 1 is applicable except as follows.

### 16.1 Addition:

*For **hotplates**, the tests are carried out with a vessel as specified for **normal operation** placed on each **cooking zone**.*

### 16.2 Addition:

*If there is earthed metal between **live parts** and the surface of glass-ceramic or similar material of **hotplates**, the leakage current is measured between **live parts** and each vessel in turn connected to the earthed metal. It shall not exceed 0,75 mA. If there is no earthed metal, the leakage current, measured between **live parts** and each of the vessels in turn, shall not exceed 0,25 mA.*

### 16.3 Addition:

*If there is earthed metal between **live parts** and the surface of glass-ceramic or similar material of **hotplates**, a test voltage of 1 250 V is applied between **live parts** and all the vessels connected to the earthed metal. If there is no earthed metal, a test voltage of 3 000 V is applied between **live parts** and the vessels.*

## 17 Overload protection of transformers and associated circuits

This clause of Part 1 is applicable.

## 18 Endurance

This clause of Part 1 is not applicable.

## 19 Abnormal operation

This clause of Part 1 is applicable except as follows.

**19.1** Addition:

*The tests of 19.4 and 19.5 are only applicable to*

- **☐A1** **breadmakers**;
- **contact grills**;
- **food dehydrators**; **☐A1**
- *the following appliances, if they incorporate a timer or if their instructions indicate a cooking operation longer than 1 h:*
  - **ovens**;
  - **roasters**;
  - **hotplates**;
  - **cookers**;
  - **rotary grills**.

*Toasters are also subjected to the tests of 19.101 and 19.102.*

*Induction hotplates are also subjected to the tests of 19.103 and 19.104.*

**19.2** Addition:

**Radiant grills** and **raclette grills** that are loaded from the front, **rotary grills**, **ovens**, **hotplates** and **cookers** are placed as near to the walls of the test corner as possible.

*Appliances are tested empty. Lids and doors are open or closed, whichever is more unfavourable. Detachable parts are in position or removed, whichever is more unfavourable.*

*Hotplates are operated without a vessel and with the controls adjusted to the highest setting.*

*Induction hotplates are operated under the conditions of Clause 11 but with empty vessels, controls being adjusted to the highest setting.*

**Cookers** are only tested with the **heating unit** that results in the most unfavourable conditions, their controls being adjusted to the highest setting. However **ovens** are operated if they do not have an indicating lamp to show when they are switched on, controls being adjusted to the highest setting.

NOTE 101 A lamp used for illuminating the **oven**, which is visible through the door and is automatically switched on and off with the **oven**, is considered to be an indicating lamp.

**19.4** Addition:

*Air-circulating fans of **food dehydrators** are disconnected.*

**19.8** Not applicable.**19.10** Not applicable.**☐C** **19.11.2** Addition:

For appliances having electronic controls, the fault conditions a) to f) are also simulated with the appliance supplied at **rated voltage** but with the controls switched off. Heating elements shall not become energized. **☐C**

**19.13** Addition:

*During the test of 19.102 any flames or smoke from the bread are ignored.*

The temperature rise of the windings of **induction hotplates** shall not exceed the values specified in 19.7.

The electric strength test of **induction hotplates** is carried out immediately after switching off the appliance.

**19.101 Toasters** are operated at **rated power input** and under **normal operation**, but without bread, for six cycles of operation. The appliance is then allowed to cool to approximately room temperature.

This test is carried out 500 times.

The mechanism shall operate satisfactorily and no sustained arcing shall occur. Electrical connections shall not work loose and the appliance shall withstand the electric strength test of 16.3.

NOTE 1 Forced cooling may be used.

NOTE 2 A simulated load may be necessary to operate the mechanism.

NOTE 3 Subclause 19.13 does not apply.

**19.102 Toasters**, loaded with the bread specified for **normal operation**, are operated at **rated power input**. The ejector mechanism is prevented from releasing and the supply is maintained to the heating elements after the timer has completed its cycle. The test is terminated after any fire has extinguished, after which any residual bread is removed from the toaster.

**19.103 Induction hotplates** are supplied at **rated voltage** and operated with a steel disk placed on the centre of the **cooking zone**. The disk has a thickness of 6 mm and the smallest diameter, rounded up to the nearest centimetre, which allows the appliance to operate.

**19.104 Induction hotplates** are supplied at **rated voltage** and operated under **normal operation** but with any control that limits the temperature during the test of Clause 11 short-circuited.

NOTE If the appliance incorporates more than one control, they are short circuited in turn.

The temperature rise of the oil shall not exceed 270 K.

## 20 Stability and mechanical hazards

This clause of Part 1 is applicable except as follows.

**20.101 Ovens** having doors with a horizontal hinge at their lower edge and on which a load is likely to be placed shall have adequate stability.

Compliance is checked by the following test.

The **oven** is placed on a horizontal surface with the door open and a mass of 3,5 kg is gently placed on the geometric centre of the door.

NOTE A sandbag may be used for the load.

The **oven** shall not tilt.

This test is not carried out on **ovens** with doors having a dimension less than 225 mm from the hinge to the opposite edge or on **ovens** with doors which cannot support dishes in the fully open position.

## 21 Mechanical strength

This clause of Part 1 is applicable except as follows.

### **A<sub>1</sub>** 21.1 Addition:

*For appliances intended for outdoor use, the impact energy is increased to 0,7 J. **A<sub>1</sub>***

*If the appliance incorporates **visibly glowing heating elements** enclosed in glass tubes, the blows are applied to the tubes as mounted in the appliance if they are*

- located at the top of the oven and accessible to test probe 41 of IEC 61032;*
- located elsewhere in the oven and accessible to test probe B of IEC 61032.*

*For **hotplates** having surfaces of glass-ceramic or similar material, three blows are applied to parts of the surface that are not exposed to impacts during the test of 21.101, the impact energy being  $0,70 \text{ J} \pm 0,05 \text{ J}$ . The blows are not applied to surfaces within 20 mm of knobs.*

NOTE 101 If the surface comprises a single piece of material, except for the outer frame, this test is not carried out.

**21.101** Surfaces of **hotplates** of glass-ceramic or similar material shall withstand the stresses liable to occur in normal use.

*Compliance is checked by the following test.*

*The **hotplate** is operated at **rated power input** with its control adjusted to the highest setting. **Induction hotplates** are operated as specified in Clause 11. When steady conditions are established, the **hotplate** is switched off and a vessel with its base horizontal is dropped from a height of 150 mm onto the **cooking zone**. The vessel has a copper or aluminium base that is flat over a diameter of  $120 \text{ mm} \pm 10 \text{ mm}$ , its edges being rounded with a radius of at least 10 mm. It is uniformly filled with at least 1,3 kg of sand or shot so that the total mass is  $1,80 \text{ kg} \pm 0,01 \text{ kg}$ .*

*The vessel is dropped 10 times onto each **cooking zone**. It is removed and the appliance is operated at **rated power input** until steady conditions are established.*

*A quantity of  $1^{+0,1}_0$  l of water containing approximately 1 % NaCl is poured steadily over the **hotplate**.*

*The appliance is then disconnected from the supply. After 15 min all excess liquid is removed and the appliance is allowed to cool to approximately room temperature. The same quantity of the saline solution is poured over the **hotplate** after which excess liquid is removed again.*

*The surface of the **hotplate** shall not be broken and the appliance shall withstand the electric strength test of 16.3.*

## 22 Construction

This clause of Part 1 is applicable except as follows.

### **22.24** Addition:

Heating elements shall be constructed or supported so they are unlikely to become displaced in normal use.

*Compliance is checked by inspection.*

**22.101 Radiant grills** shall not incorporate a timer that is intended to delay the operation of a heating element, unless they have a **thermostat** and are incorporated in an **oven** or other compartment.

*Compliance is checked by inspection.*

**22.102 Barbecues** shall not have bare heating elements.

Bare heating elements for **ovens** shall only be located at the top of the heated compartment.

*Compliance is checked by inspection.*

**22.103 Oven** vents shall be constructed so that they do not discharge moisture or grease in such a way that **clearances** and **creepage distances** are affected.

*Compliance is checked by inspection.*

**22.104 Ovens** shall be constructed so that shelves can easily slide in the supports and do not fall out of position when the sides are displaced as much as possible.

*Compliance is checked by inspection and by manual test.*

**22.105** Appliances shall not have openings on the underside that would allow small items to penetrate and touch **live parts**.

*Compliance is checked by inspection and by measuring the distance between the supporting surface and **live parts** through openings. This distance shall be at least 6 mm. However, if the appliance is fitted with legs, this distance is increased to 10 mm if the appliance is intended to stand on a table and to 20 mm if it is intended to stand on the floor.*

**22.106** Grills and **barbecues** shall be constructed so that their heating elements are fixed in position or prevented from operating when they are not in their normal position of use.

*Compliance is checked by inspection.*

**22.107 Hotplates** shall be constructed so that heating elements are prevented from rotating about a vertical axis and are adequately supported in all positions of adjustment of their supports.

NOTE If a heating element is clamped by a nut on a central stud, an additional means is required to prevent its rotation.

*Compliance is checked by inspection.*

**22.108 Hotplates** shall be constructed so that inadvertent operation of **touch controls** is unlikely if this could give rise to a hazardous situation due to

- spillage of liquids, including that caused by a vessel boiling over;
- a damp cloth placed on the control panel.

*Compliance is checked by the following test, the appliance being supplied at **rated voltage**.*

*Sufficient water to completely cover the control panel to a depth not exceeding 2 mm, with a minimum of 140 ml, is poured steadily over the control panel so that bridging occurs between combinations of touch pads.*

*The test is carried out with each heating element energised in turn and then without energising any heating element.*

*A cloth having a mass between 140 g/m<sup>2</sup> and 170 g/m<sup>2</sup> and dimensions of 400 mm × 400 mm is folded four times into a square pad and saturated with water. It is placed over the control panel in any position.*

*There shall be no inadvertent operation of any heating element for longer than 10 s.*

**22.109 Hotplates** incorporating **touch controls** shall require at least two manual operations to switch on a heating element but only one to switch it off.

NOTE Touching the contact surface at the same point twice is not considered to be two operations.

*Compliance is checked by manual test.*

**22.110 Induction hotplates** shall be constructed so that they can only be operated with a suitable vessel placed on the **cooking zone**.

*Compliance is checked by the following test, the appliance being supplied at **rated voltage**.*

*An iron bar 2 mm thick having dimensions 100 mm × 20 mm is placed in the most unfavourable position on the **cooking zone**. The controls are adjusted to their maximum setting.*

*The temperature rise of the bar shall not exceed 35 K.*

**A1** **22.111** Heating elements in **breadmakers** shall be located so that they are not exposed to dough that may rise over the edge of the dough container during normal use of the appliance.

*Compliance is checked by inspection.*

**22.112** Reconnection of the power supply to a **breadmaker** after an interruption shall not result in a fire due to an extended heating period.

*Compliance is checked by the following test.*

*All batteries are removed and the **breadmaker** is supplied at **rated voltage** and operated in its heating mode without a load.*

*After 1 min, the power supply is interrupted for a period of 5 min and then restored. The appliance shall continue to operate in its heating mode from the same point in the cycle, or a manual operation shall be required to restart it.*

*If the appliance continues to operate automatically, the test is repeated but with a 5 min longer period of interruption. If the appliance still continues to operate automatically, the test is repeated but with the periods of interruption increased by at least 5 min each time.*

*The appliance shall eventually require a manual operation to restart it. **A1***

## 23 Internal wiring

This clause of Part 1 is applicable except as follows.



**23.3 Addition:**

For appliances which can be opened to two positions, 1 000 flexings are made with the part moved to the fully open position and the remaining flexings to the other position.

**24 Components**

This clause of Part 1 is applicable except as follows.

**24.1.3 Addition:**

Switches controlling heating elements of **hotplates** are subjected to 50 000 cycles of operation.

**24.1.4 Modification**

The following numbers of cycles of operation apply:

- energy regulators
  - for automatic action 100 000
  - for manual action 10 000
- **self-resetting thermal cut-outs** for heating elements of glass-ceramic **hotplates** 100 000

**24.1.5 Addition:**

For appliance couplers incorporating **thermostats**, **thermal cut-outs** or fuses in the connectors, IEC 60320-1 is applicable except that

- the earthing contact of the connector is allowed to be accessible, provided that this contact is not likely to be gripped during insertion or withdrawal of the connector;
- the temperature required for the test of Clause 18 is that measured on the pins of the appliance inlet during the test of Clause 11 of this standard;
- the breaking-capacity test of Clause 19 is carried out using the inlet of the appliance;
- the temperature rise of current-carrying parts specified in Clause 21 is not determined.

NOTE 101 Thermal controls are not allowed in connectors complying with the standard sheets of IEC 60320-1.

**24.101 Thermostats** and energy regulators incorporating an **off position** shall not switch on as a result of variations in ambient temperature.

Compliance is checked by the following test that is carried out on three devices.

The device, set at the **off position**, is placed for 2 h in an ambient temperature of  $-20 \frac{0}{5}^{\circ}\text{C}$  and then at

- $t^{\circ}\text{C}$ , where  $t$  is the temperature according to the  $T$ -marking;
- $55^{\circ}\text{C}$ , for devices without a  $T$ -marking.

During the test the **off position** shall be maintained.

A test voltage of 500 V is applied across the contacts for 1 min. No breakdown shall occur.

**24.102 Thermal cut-outs** incorporated in **food dehydrators** for compliance with 19.4 shall not be self-resetting.

Compliance is checked by inspection.

## 25 Supply connection and external flexible cords

This clause of Part 1 is applicable except as follows.

### 25.1 Addition:

Appliances incorporating an appliance inlet that does not comply with the standard sheets of IEC 60320-1 shall be supplied with a cord set.

### **A<sub>1</sub>** 25.7 Addition:

The **supply cord** of appliances intended for outdoor use shall be polychloroprene sheathed. **A<sub>1</sub>**

## 26 Terminals for external conductors

This clause of Part 1 is applicable.

## 27 Provision for earthing

This clause of Part 1 is applicable except as follows.

### 27.1 Addition:

Earthing continuity shall not depend upon flexible metallic tubes, coiled springs or cord anchorages.

## 28 Screws and connections

This clause of Part 1 is applicable.

## 29 Clearances, creepage distances and solid insulation

This clause of Part 1 is applicable except as follows.

### 29.2 Addition:

The microenvironment is pollution degree 3 unless the insulation is enclosed or located so that it is unlikely to be exposed to pollution during normal use of the appliance.

### 29.3 Addition:

This requirement does not apply to the sheath of a **visibly glowing heating element** that is inaccessible to test probe 41 of IEC 61032.

## 30 Resistance to heat and fire

This clause of Part 1 is applicable except as follows.

### 30.1 Addition:

*Temperature rises occurring during the test of 19.101 are not taken into account.*

**30.2 Addition:**

Ⓐ<sub>1</sub> The tests of 30.2.3 are applicable to

- **breadmakers;**
- **food dehydrators;**
- *the following appliances if they incorporate a timer or if their instructions indicate a cooking operation longer than 1 h:*
  - **cookers;**
  - **ovens;**
  - **roasters;**
  - **rotary grills.**

*For other appliances, the tests of 30.2.2 are applicable.* Ⓐ<sub>1</sub>

**31 Resistance to rusting**

Ⓐ<sub>1</sub> This clause of Part 1 is applicable except as follows.

*Addition:*

*For appliances intended for outdoor use, compliance is checked by the salt mist test, Kb of IEC 60068-2-52, severity 2 being applicable.*

*Before the test, enclosures having a coating are scratched by means of a hardened steel pin, the end of which has the form of a cone with a top angle of 40°. Its tip is rounded with a radius of 0,25 mm ± 0,02 mm. The pin is loaded so that the force exerted along its axis is 10 N ± 0,5 N. The pin is held at an angle of 80° – 85° to the horizontal and scratches are made by drawing the pin along the surface of the coating at a speed of approximately 20 mm/s. Five scratches are made at least 5 mm apart and at least 5 mm from the edges.*

*After the test, the appliance shall not have deteriorated to such an extent that compliance with this standard, in particular with Clauses 8 and 27, is impaired. The coating shall not be broken and shall not have loosened from the surface.* Ⓐ<sub>1</sub>

**32 Radiation, toxicity and similar hazards**

This clause of Part 1 is applicable.

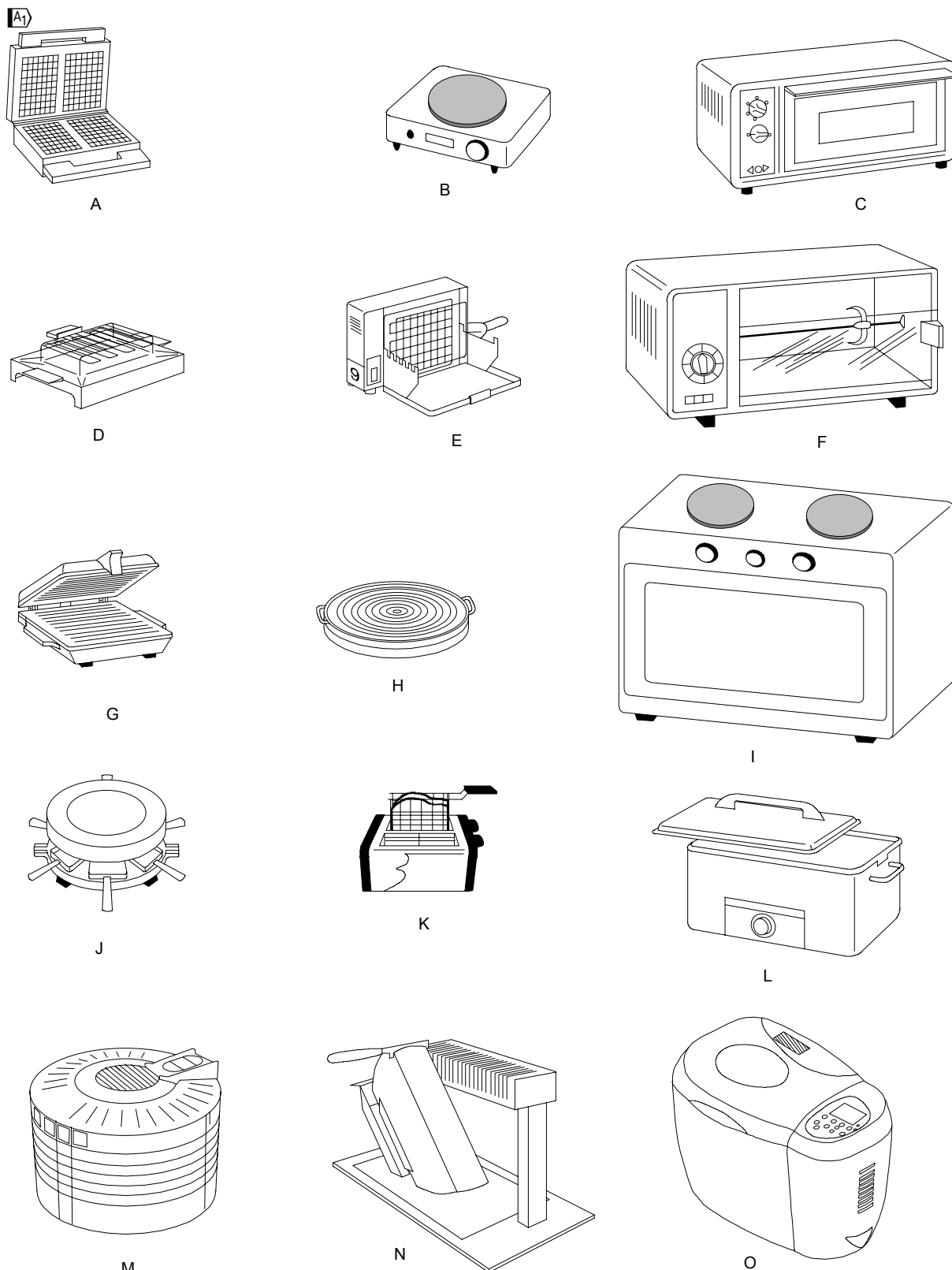

**Key**

- A Waffle iron
- B Hotplate
- C Oven
- D Barbecue
- E Radiant grill
- F Rotary grill
- G Contact grill

- H Griddle
- I Cooker
- J Raclette grill
- K Toaster and sandwich-toasting attachment
- L Roaster
- M Food dehydrator
- N Raclette appliance
- O Breadmaker

IEC 161/04

**Figure 101 – Examples of appliances** A1

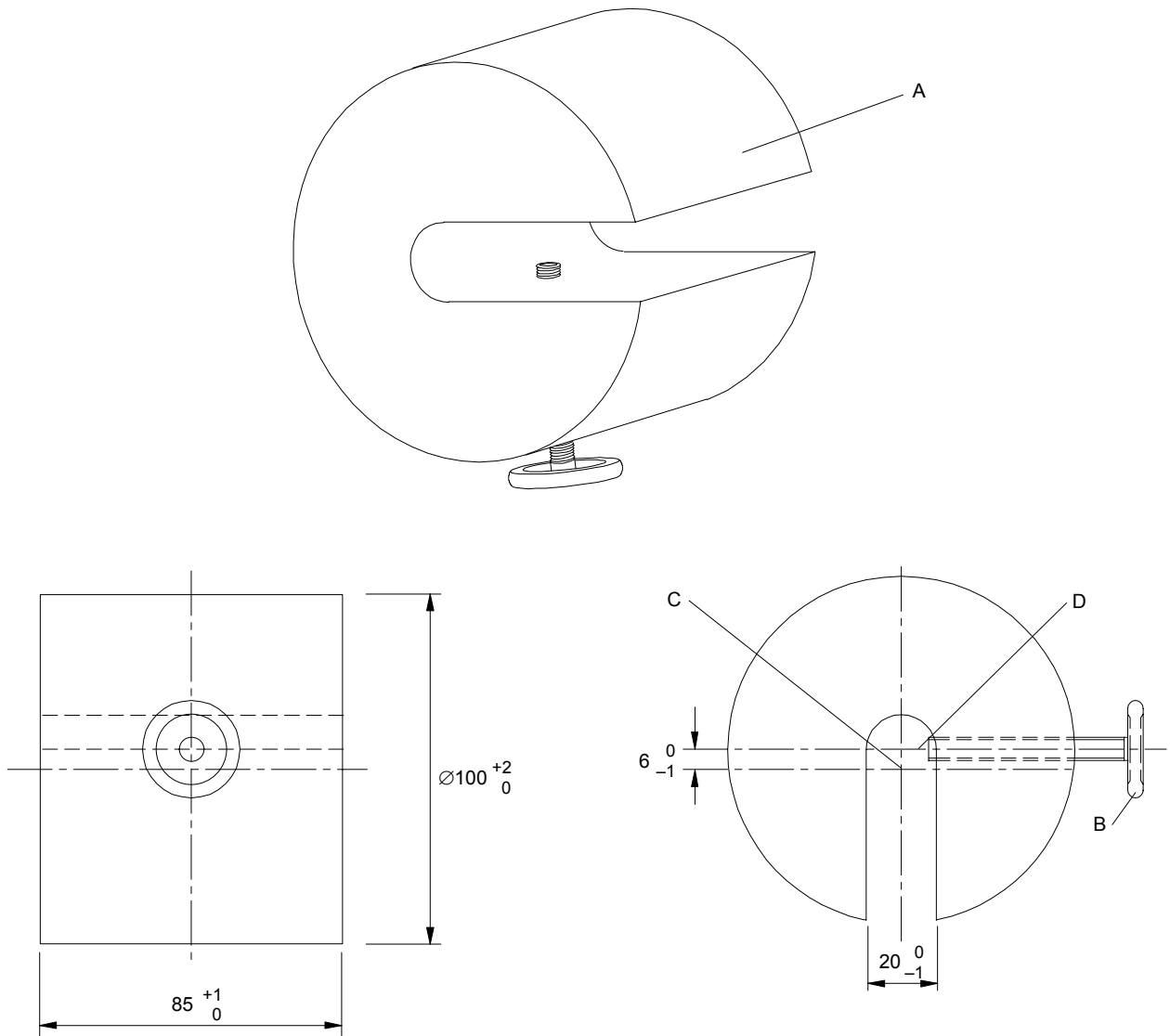

IEC 804/02

Dimensions in millimetres

**Key**

- A Load, mass approximately 4,5 kg
- B Fixing screw
- C Axis of load
- D Axis of fixing screw

NOTE The load is positioned on the rotary spit so that the fixing screw contacts the diameter of the spit.

**Figure 102 – Load for testing rotating spits**

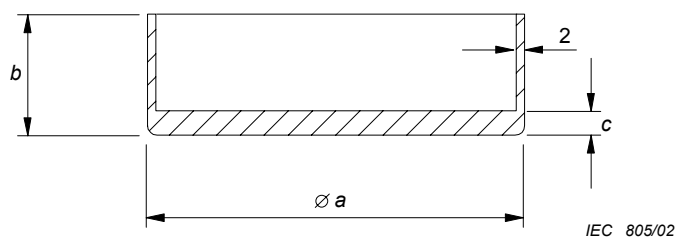

Dimensions in millimetres

Diameter of cooking zone mm	Approximate dimension		
	a mm	b mm	c mm
≤110	110	140	8
>110 ≤ 145	145	140	8
>145 ≤ 180	180	140	9
>180 ≤ 220	220	120	10
>220 ≤ 300	300	100	10

NOTE The maximum concavity of the vessel is to be not more than 0,05 mm. The base of the vessel is not to be convex.

Figure 103 – Vessel for testing hotplates

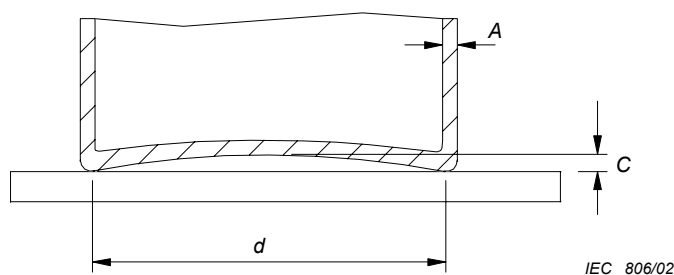

**Key**

A Base and wall thickness, 2 mm ± 0,5 mm

C Maximum concavity

$\boxed{A_1}$  d Diameter of the flat area of the base  $\boxed{A_1}$

NOTE The vessel is made of low carbon steel having a maximum carbon content of 0,08 %. It is cylindrical without metallic handles or protrusions. The diameter of the flat area of the base of the vessel is to be at least the diameter of the **cooking zone**. The maximum concavity of the base of the vessel is 0,006 d. The base of the vessel is not to be convex.

Figure 104 – Vessel for testing induction hotplates

## Annexes

The annexes of Part 1 are applicable except as follows.

### Annex C (normative)

#### Ageing test on motors

*Modification:*

The value of  $p$  in Table C.1 is 2 000.



### Annex ZC (normative)

#### Normative references to international publications with their corresponding European publications

*Addition:*

<u>Publication</u>	<u>Year</u>	<u>Title</u>	<u>EN/HD</u>	<u>Year</u>
IEC 60068-2-52	- <sup>1)</sup>	Environmental testing – Part 2: Tests – Test Kb: Salt mist, cyclic (sodium chloride solution)	EN 60068-2-52	1996 <sup>2)</sup>



1) undated reference

2) valid edition at date of issue

## **Bibliography**

The bibliography of Part 1 is applicable except as follows.

*Addition:*

IEC 60335-2-6, *Household and similar electrical appliances – Safety – Part 2-6: Particular requirements for stationary cooking ranges, hobs, ovens and similar appliances*

IEC 60335-2-12, *Household and similar electrical appliances – Safety – Part 2-12: Particular requirements for warming plates and similar appliances*

IEC 60335-2-13, *Household and similar electrical appliances – Safety – Part 2-13: Particular requirements for deep fat fryers, frying pans and similar appliances*

IEC 60335-2-25, *Household and similar electrical appliances – Safety – Part 2-25: Particular requirements for microwave ovens*

IEC 60335-2-78, *Household and similar electrical appliances – Safety – Part 2-78: Particular requirements for outdoor barbecues*

---





---

---

## BSI — British Standards Institution

BSI is the independent national body responsible for preparing British Standards. It presents the UK view on standards in Europe and at the international level. It is incorporated by Royal Charter.

### Revisions

British Standards are updated by amendment or revision. Users of British Standards should make sure that they possess the latest amendments or editions.

It is the constant aim of BSI to improve the quality of our products and services. We would be grateful if anyone finding an inaccuracy or ambiguity while using this British Standard would inform the Secretary of the technical committee responsible, the identity of which can be found on the inside front cover. Tel: +44 (0)20 8996 9000. Fax: +44 (0)20 8996 7400.

BSI offers members an individual updating service called PLUS which ensures that subscribers automatically receive the latest editions of standards.

### Buying standards

Orders for all BSI, international and foreign standards publications should be addressed to Customer Services. Tel: +44 (0)20 8996 9001. Fax: +44 (0)20 8996 7001. Email: [orders@bsi-global.com](mailto:orders@bsi-global.com). Standards are also available from the BSI website at <http://www.bsi-global.com>.

In response to orders for international standards, it is BSI policy to supply the BSI implementation of those that have been published as British Standards, unless otherwise requested.

### Information on standards

BSI provides a wide range of information on national, European and international standards through its Library and its Technical Help to Exporters Service. Various BSI electronic information services are also available which give details on all its products and services. Contact the Information Centre. Tel: +44 (0)20 8996 7111. Fax: +44 (0)20 8996 7048. Email: [info@bsi-global.com](mailto:info@bsi-global.com).

Subscribing members of BSI are kept up to date with standards developments and receive substantial discounts on the purchase price of standards. For details of these and other benefits contact Membership Administration. Tel: +44 (0)20 8996 7002. Fax: +44 (0)20 8996 7001. Email: [membership@bsi-global.com](mailto:membership@bsi-global.com).

Information regarding online access to British Standards via British Standards Online can be found at <http://www.bsi-global.com/bsonline>.

Further information about BSI is available on the BSI website at <http://www.bsi-global.com>.

### Copyright

Copyright subsists in all BSI publications. BSI also holds the copyright, in the UK, of the publications of the international standardization bodies. Except as permitted under the Copyright, Designs and Patents Act 1988 no extract may be reproduced, stored in a retrieval system or transmitted in any form or by any means – electronic, photocopying, recording or otherwise – without prior written permission from BSI.

This does not preclude the free use, in the course of implementing the standard, of necessary details such as symbols, and size, type or grade designations. If these details are to be used for any other purpose than implementation then the prior written permission of BSI must be obtained.

Details and advice can be obtained from the Copyright & Licensing Manager. Tel: +44 (0)20 8996 7070. Fax: +44 (0)20 8996 7553. Email: [copyright@bsi-global.com](mailto:copyright@bsi-global.com).