

INTERNATIONAL STANDARD

IEC
60335-2-6

Fifth edition
2002-07

Household and similar electrical appliances – Safety –

Part 2-6: Particular requirements for stationary cooking ranges, hobs, ovens and similar appliances

*Appareils électrodomestiques et analogues –
Sécurité –*

*Partie 2-6:
Règles particulières pour les cuisinières, les tables
de cuisson, les fours et appareils fixes analogues*



Reference number
IEC 60335-2-6:2002(E)

Publication numbering

As from 1 January 1997 all IEC publications are issued with a designation in the 60000 series. For example, IEC 34-1 is now referred to as IEC 60034-1.

Consolidated editions

The IEC is now publishing consolidated versions of its publications. For example, edition numbers 1.0, 1.1 and 1.2 refer, respectively, to the base publication, the base publication incorporating amendment 1 and the base publication incorporating amendments 1 and 2.

Further information on IEC publications

The technical content of IEC publications is kept under constant review by the IEC, thus ensuring that the content reflects current technology. Information relating to this publication, including its validity, is available in the IEC Catalogue of publications (see below) in addition to new editions, amendments and corrigenda. Information on the subjects under consideration and work in progress undertaken by the technical committee which has prepared this publication, as well as the list of publications issued, is also available from the following:

- **IEC Web Site** (www.iec.ch)

- **Catalogue of IEC publications**

The on-line catalogue on the IEC web site (www.iec.ch/catlg-e.htm) enables you to search by a variety of criteria including text searches, technical committees and date of publication. On-line information is also available on recently issued publications, withdrawn and replaced publications, as well as corrigenda.

- **IEC Just Published**

This summary of recently issued publications (www.iec.ch/JP.htm) is also available by email. Please contact the Customer Service Centre (see below) for further information.

- **Customer Service Centre**

If you have any questions regarding this publication or need further assistance, please contact the Customer Service Centre:

Email: custserv@iec.ch
Tel: +41 22 919 02 11
Fax: +41 22 919 03 00

INTERNATIONAL STANDARD

IEC 60335-2-6

Fifth edition
2002-07

Household and similar electrical appliances – Safety –

Part 2-6: Particular requirements for stationary cooking ranges, hobs, ovens and similar appliances

*Appareils électrodomestiques et analogues –
Sécurité –*

*Partie 2-6:
Règles particulières pour les cuisinières, les tables
de cuisson, les fours et appareils fixes analogues*

© IEC 2002 — Copyright - all rights reserved

No part of this publication may be reproduced or utilized in any form or by any means, electronic or mechanical, including photocopying and microfilm, without permission in writing from the publisher.

International Electrotechnical Commission, 3, rue de Varembé, PO Box 131, CH-1211 Geneva 20, Switzerland
Telephone: +41 22 919 02 11 Telefax: +41 22 919 03 00 E-mail: inmail@iec.ch Web: www.iec.ch



Commission Electrotechnique Internationale
International Electrotechnical Commission
Международная Электротехническая Комиссия

PRICE CODE

R

For price, see current catalogue

CONTENTS

FOREWORD	4
INTRODUCTION	7
1 Scope	8
2 Normative references.....	8
3 Definitions	9
4 General requirement.....	12
5 General conditions for the tests	12
6 Classification	12
7 Marking and instructions	12
8 Protection against access to live parts	15
9 Starting of motor-operated appliances	15
10 Power input and current.....	15
11 Heating.....	16
12 Void	20
13 Leakage current and electric strength at operating temperature	20
14 Transient overvoltages.....	20
15 Moisture resistance.....	21
16 Leakage current and electric strength	22
17 Overload protection of transformers and associated circuits.....	22
18 Endurance	23
19 Abnormal operation.....	23
20 Stability and mechanical hazards.....	24
21 Mechanical strength.....	25
22 Construction	27
23 Internal wiring	30
24 Components	31
25 Supply connection and external flexible cords.....	32
26 Terminals for external conductors	32
27 Provision for earthing.....	32
28 Screws and connections	32
29 Clearances, creepage distances and solid insulation	32
30 Resistance to heat and fire	32
31 Resistance to rusting	33
32 Radiation, toxicity and similar hazards	33
Annexes.....	38
Bibliography.....	38

Figure 101 – Vessel for testing hob elements34
Figure 102 – Vessel for testing induction hob elements35
Figure 103 – Load for testing rotating spits36
Figure 104 – Probe for measuring surface temperatures37

INTERNATIONAL ELECTROTECHNICAL COMMISSION

**HOUSEHOLD AND SIMILAR ELECTRICAL APPLIANCES –
SAFETY –**

**Part 2-6: Particular requirements for stationary cooking ranges,
hobs, ovens and similar appliances**

FOREWORD

- 1) The IEC (International Electrotechnical Commission) is a worldwide organization for standardization comprising all national electrotechnical committees (IEC National Committees). The object of the IEC is to promote international co-operation on all questions concerning standardization in the electrical and electronic fields. To this end and in addition to other activities, the IEC publishes International Standards. Their preparation is entrusted to technical committees; any IEC National Committee interested in the subject dealt with may participate in this preparatory work. International, governmental and non-governmental organizations liaising with the IEC also participate in this preparation. The IEC collaborates closely with the International Organization for Standardization (ISO) in accordance with conditions determined by agreement between the two organizations.
- 2) The formal decisions or agreements of the IEC on technical matters express, as nearly as possible, an international consensus of opinion on the relevant subjects since each technical committee has representation from all interested National Committees.
- 3) The documents produced have the form of recommendations for international use and are published in the form of standards, technical specifications, technical reports or guides and they are accepted by the National Committees in that sense.
- 4) In order to promote international unification, IEC National Committees undertake to apply IEC International Standards transparently to the maximum extent possible in their national and regional standards. Any divergence between the IEC Standard and the corresponding national or regional standard shall be clearly indicated in the latter.
- 5) The IEC provides no marking procedure to indicate its approval and cannot be rendered responsible for any equipment declared to be in conformity with one of its standards.
- 6) Attention is drawn to the possibility that some of the elements of this International Standard may be the subject of patent rights. The IEC shall not be held responsible for identifying any or all such patent rights.

This part of International Standard IEC 60335 has been prepared by IEC technical committee 61: Safety of household and similar electrical appliances.

This fifth edition cancels and replaces the fourth edition published in 1997 and its amendment 1 (2000). It constitutes a technical revision.

The text of this part of IEC 60335 is based on the following documents:

FDIS	Report on voting
61/2137/FDIS	61/2162/RVD

Full information on the voting for the approval of this standard can be found in the report on voting indicated in the above table.

This part 2 is to be used in conjunction with the latest edition of IEC 60335-1 and its amendments. It was established on the basis of the fourth edition (2001) of that standard.

NOTE 1 When "Part 1" is mentioned in this standard, it refers to IEC 60335-1.

This part 2 supplements or modifies the corresponding clauses in IEC 60335-1, so as to convert that publication into the IEC standard: Safety requirements for stationary electric cooking ranges, hobs, ovens and similar appliances.

When a particular subclause of Part 1 is not mentioned in this part 2, that subclause applies as far as is reasonable. When this standard states "addition", "modification" or "replacement", the relevant text in Part 1 is to be adapted accordingly.

NOTE 2 The following numbering system is used:

- subclauses, tables and figures that are numbered starting from 101 are additional to those in Part 1;
- unless notes are in a new subclause or involve notes in Part 1, they are numbered starting from 101, including those in a replaced clause or subclause;
- additional annexes are lettered AA, BB, etc.

NOTE 3 The following print types are used:

- requirements: in roman type;
- *test specifications: in italic type;*
- notes: in small roman type.

Words in **bold** in the text are defined in Clause 3. When a definition concerns an adjective, the adjective and the associated noun are also in bold.

The committee has decided that the contents of this publication will remain unchanged until 2003. At this date, the publication will be

- reconfirmed;
- withdrawn;
- replaced by a revised edition, or
- amended.

The following differences exist in the countries indicated below.

- 3.1.6: The diversity factor is not used (USA).
- 3.1.9: Other test conditions are used (USA).
- 6.1: Class 0I appliances are allowed (Japan).
- 7.1: Instructions for pyrolytic self-cleaning ovens are to be marked on the outside of the oven (USA).
- 7.1: Miniature fuse links are not to be used to protect socket-outlets (USA).
- 7.12: The minimum indicated water pressure is 1 MPa (Norway).
- 7.12.4: The instructions shall state the name of the manufacturer and model number of the control panel to be used with built-in appliances (USA).
- 11.7: The duration of the test is different (Canada and USA).
- 11.8: 65 K applies for all wooden surfaces (Norway, Sweden and USA).
- 11.8: Lower temperature limits apply to handles, knobs and other surfaces accessible during the self-cleaning operation (USA).
- 11.101: The test is different (Australia, Canada and USA).
- 13.2: Leakage current measurements are not carried out (USA).
- 13.3: The electric strength test is not carried out (USA).
- 15.2: Tests are only carried out on controls mounted in the hob surface (USA).
- 16.2: Leakage current measurements are not carried out (USA).
- 19.4: The temperature limit is 315 °C (USA).
- 19.101: Different disc sizes are used (USA).
- 20.101: Heavier loads are used (USA).
- 21.101: Additional requirements for oven shelves are specified (Australia, New Zealand and USA).
- 21.102: Different test loads and test methods are used (USA).
- Clause 22: Ovens installed at a height below 80 cm above the floor shall be constructed so that the oven door cannot be opened by a simple operation (Sweden).
- Clause 22: Hob elements are required to be inaccessible to children (Sweden).
- 22.2: For appliances with more than one heating unit, each unit shall be provided with all-pole disconnection (Norway).

- 22.107: The requirement does not apply (USA).
- 22.108: The test is different (USA).
- 22.109: A centre oven temperature of 315 °C is specified (USA).
- 22.110: Larger quantities of different soils are used (USA).
- 22.111: Larger quantities of different soils are used (USA).
- 22.113: The test is not carried out (USA).
- 22.115: The test is not carried out (USA).
- 24.1.4: The number of cycles of operation is different (USA).
- 24.101: Socket-outlets have to be provided with residual current devices which may be combined with the overcurrent protective device (Australia).
- 24.102: The current limitation is different and socket-outlets are required to be de-energized when the cooking elements are in use (USA).
- 25.3: Ranges that are not built-in shall not be permanently connected to the fixed wiring (New Zealand and Norway).
- Clause 27: Earthing terminals are permitted to be connected to the neutral (USA).

INTRODUCTION

It has been assumed in the drafting of this International Standard that the execution of its provisions is entrusted to appropriately qualified and experienced persons.

This standard recognizes the internationally accepted level of protection against hazards such as electrical, mechanical, thermal, fire and radiation of appliances when operated as in normal use taking into account the manufacturer's instructions. It also covers abnormal situations that can be expected in practice.

This standard takes into account the requirements of IEC 60364 as far as possible so that there is compatibility with the wiring rules when the appliance is connected to the supply mains. However, national wiring rules may differ.

If an appliance within the scope of this standard also incorporates functions that are covered by another part 2 of IEC 60335, the relevant part 2 is applied to each function separately, as far as is reasonable. If applicable, the influence of one function on the other is taken into account.

This standard is a product family standard dealing with the safety of appliances and takes precedence over horizontal and generic standards covering the same subject.

An appliance that complies with the text of this standard will not necessarily be considered to comply with the safety principles of the standard if, when examined and tested, it is found to have other features that impair the level of safety covered by these requirements.

An appliance employing materials or having forms of construction differing from those detailed in the requirements of this standard may be examined and tested according to the intent of the requirements and, if found to be substantially equivalent, may be considered to comply with the standard.

HOUSEHOLD AND SIMILAR ELECTRICAL APPLIANCES – SAFETY –

Part 2-6: Particular requirements for stationary cooking ranges, hobs, ovens and similar appliances

1 Scope

This clause of Part 1 is replaced by the following.

This International Standard deals with the safety of **stationary electric cooking ranges, hobs, ovens** and similar appliances for household use, their **rated voltage** being not more than 250 V for single-phase appliances connected between one phase and neutral, and 480 V for other appliances.

NOTE 101 Examples of appliances that are within the scope of this standard are

- **griddles;**
- **grills;**
- **induction hobs;**
- **pyrolytic self-cleaning ovens;**
- **steam ovens.**

As far as is practicable, this standard deals with the common hazards presented by appliances that are encountered by all persons in and around the home. However, in general, it does not take into account

- the use of appliances by young children or infirm persons without supervision;
- playing with the appliance by young children.

NOTE 102 Attention is drawn to the fact that

- for appliances intended to be used in vehicles or on board ships or aircraft, additional requirements may be necessary;
- in many countries additional requirements are specified by the national health authorities, the national authorities responsible for the protection of labour, the national water supply authorities and similar authorities.

NOTE 103 This standard does not apply to

- appliances intended for commercial catering;
- appliances intended to be used in locations where special conditions prevail, such as the presence of a corrosive or explosive atmosphere (dust, vapour or gas);
- grills, toasters and similar portable cooking appliances (IEC 60335-2-9);
- microwave ovens (IEC 60335-2-25).

2 Normative references

This clause of Part is applicable except as follows.

Addition:

IEC 60584-1, *Thermocouples – Part 1: Reference tables*

3 Definitions

This clause of Part 1 is applicable except as follows.

3.1.6 Addition:

NOTE 101 For appliances having more than three **heating units** per phase, a diversity factor is applied to the **rated current** or **rated power input** when determining the current used to establish the size of the terminals and the nominal cross-sectional area of the **supply cord**. The diversity factor F is calculated from the following formula, where N is the number of **heating units** per phase that can be energized together:

$$F = 0,35 + \frac{0,65}{\sqrt{N}}$$

3.1.9 Replacement:

normal operation

operation of the appliance as specified in 3.1.9.101 to 3.1.9.107

3.1.9.101 Hob elements, other than **induction hob elements**, are operated with vessels containing cold water. The vessel is made of unpolished commercial quality aluminium, has a flat bottom and is covered with a lid. Thermal controls are adjusted to their highest setting until the water boils and then adjusted so that the water boils gently. Water is added to maintain the level during boiling.

NOTE 1 The lid is positioned so that steam does not affect the test.

In case of doubt, vessels as specified in Figure 101 are used.

Induction hob elements are operated with vessels as specified in Figure 102 that contain approximately half their capacity of cooking oil at room temperature. Thermal controls are adjusted to their highest setting until the oil temperature reaches $180\text{ °C} \pm 4\text{ °C}$ and then adjusted so that this temperature is maintained.

For all **hob elements** the diameter of the bottom of the vessel is approximately equal to the diameter of the **cooking zone** and the quantity of liquid is specified in Table 101. The vessel is positioned centrally on the **cooking zone**.

NOTE 2 If several **cooking zones** are marked for one **hob element**, the most unfavourable zone is used for the test.

NOTE 3 For non-circular **cooking zones**, the smallest non-circular vessel is used which will cover the **cooking zone** as far as possible, taking into account the **hob rim** and the other vessels. The quantity of liquid is determined on the basis of the minor diameter of the **cooking zone**.

Table 101 – Quantity of liquid in the vessel

Diameter of cooking zone mm	Quantity of water or oil l
≤ 110	0,6
> 110 and ≤ 145	1,0
> 145 and ≤ 180	1,5
> 180 and ≤ 220	2,0
> 220 and ≤ 300	3,0

3.1.9.102 Ovens are operated empty with the door closed. Thermal controls are adjusted so that the mean temperature in the centre of the **oven** is maintained at

- $220\text{ °C} \pm 4\text{ °C}$ for **ovens** with forced air circulation;
- $240\text{ °C} \pm 4\text{ °C}$ for other **ovens**.

NOTE If the temperature cannot be attained, the thermal control is adjusted to its highest setting.

Ovens without thermal controls are switched on and off so that the temperature in the centre of the **oven** is maintained at $240\text{ °C} \pm 15\text{ °C}$.

Steam ovens are operated in accordance with the instructions. Controls are adjusted to their highest setting until the cooking temperature is reached and then adjusted to the lowest setting that maintains this temperature.

Steam generators intended to be filled by hand are filled according to the instructions, water being added to maintain the steam generation.

Steam generators intended to be filled automatically are connected to a water supply, the pressure of which is set according to the instructions.

The supply water has a temperature of

- $15\text{ °C} \pm 5\text{ °C}$ for appliances to be connected to a cold water supply;
- $60\text{ °C} \pm 5\text{ °C}$ or the temperature indicated in the instructions, whichever is the higher, for appliances to be connected to a hot water supply.

Steam ovens are also operated while generating steam but with the thermal controls adjusted as for operation without steam.

3.1.9.103 Grills are operated empty with the grill pan and food supports in the most unfavourable position for normal use, the door and any other accessories being positioned in accordance with the instructions. In the absence of such instructions, the door and other accessories are placed in the most unfavourable position in which they may be left. Thermal controls are adjusted to their highest setting. However, if the instructions for **grills** incorporated in **ovens** specify a lower setting, this setting is used. Any reflectors intended to be placed above heating elements are in position.

3.1.9.104 Rotating spits in **ovens** or **grills** are operated with the load on the rotating spit as shown in Figure 103. The appliance is operated taking into account the instructions with regard to

- the heating elements to be operated;
- the setting of the thermal control;
- the position of the door and grill pan.

In the absence of such instructions, the control is adjusted to its highest setting and the door is fully open or is placed in the most unfavourable intermediate position in which it may be left.

Any grill pan is placed in its lowest position.

3.1.9.105 Warming drawers and similar compartments are operated in the closed position with their controls adjusted to the highest setting.

3.1.9.106 Griddles are operated so that the temperature at the centre of the heated surface is maintained at $275\text{ °C} \pm 15\text{ °C}$ by adjusting their thermal controls or by switching the supply on or off.

3.1.9.107 Cooking ranges are operated with their individual **heating units** being operated under their stated conditions of **normal operation**.

3.101

oven

appliance having a heated cavity with a door and constructed so that food, which may be in a container, can be placed on a shelf

3.102

grill

heating unit constructed so that the food is supported on a grid or spit and is cooked by radiant heat

NOTE The cooking operation in a **grill** is known as grilling or broiling.

3.103**hob**

appliance that incorporates a **hob surface** and one or more **hob elements**, and is built in or part of a **cooking range**

3.104**cooking range**

appliance incorporating a **hob** and an **oven** and which may incorporate a **grill** or **griddle**

3.105**pyrolytic self-cleaning oven**

oven in which cooking deposits are removed by heating the **oven** to a temperature exceeding 350 °C

3.106**steam oven**

oven intended for cooking food by steam generated at atmospheric pressure in the appliance

3.107**griddle**

heating unit having a surface on which the food is placed directly for cooking

3.108**induction hob**

hob containing at least one **induction hob element**

3.109**heating unit**

any part of the appliance that fulfils an independent cooking or warming function

NOTE Examples are **hob elements**, **ovens**, **grills** and warming drawers.

3.110**hob surface**

horizontal part of the appliance on which vessels can be placed

3.111**hob element**

heating unit attached to the **hob surface** or positioned below the **cooking zone**

3.112**induction hob element**

hob element that heats metallic vessels by means of eddy currents

NOTE The eddy currents are induced in the bottom of the vessel by the electromagnetic field of a coil.

3.113**pan detector**

device incorporated in a **hob element** that prevents its operation unless a vessel is placed on the **cooking zone**

3.114**cooking zone**

area marked on a **hob surface** where the vessel is placed for heating food

NOTE When a **hob element** protrudes above the **hob surface**, its surface is the **cooking zone**.

3.115

touch control

control actuated by contact or proximity of a finger, with little or no movement of the contact surface

3.116

temperature-sensing probe

device that is inserted into the food to measure its temperature and which is a part of an **oven** control

3.117

rated water pressure

water pressure assigned to the appliance by the manufacturer

4 General requirement

This clause of Part 1 is applicable.

5 General conditions for the tests

This clause of Part 1 is applicable except as follows.

5.3 Addition:

*For **pyrolytic self-cleaning ovens**, the tests of 22.108 to 22.111 are carried out before the tests of Clause 19.*

5.4 Addition:

*Appliances that also use gas are supplied with gas at the appropriate rated pressure. Vessels having a diameter of approximately 220 mm are filled with 2 l of water, covered with a lid and placed on the **hob** burners. The controls are adjusted to their highest setting until the water boils. They are then adjusted so that the water simmers, water being added when necessary to maintain the level.*

5.101 Class III temperature-sensing probes are only subjected to the tests of Clause 19.

6 Classification

This clause of Part 1 is applicable except as follows.

6.1 Modification:

Appliances shall be **class I**, **class II** or **class III**.

7 Marking and instructions

This clause of Part 1 is applicable except as follows.

7.1 Addition:

The total **rated power input** or **rated current** of **induction hob elements** shall be marked.

If a **cooking range** incorporates a socket-outlet protected by means of fuses, other than D type fuses, it shall be marked with the rated current of the relevant fuse. When a miniature fuse-link is provided, this marking shall indicate that the fuse-link is to have a high breaking capacity.

7.6 Addition:



[symbol 5010 of IEC 60417-1] ON/OFF (push-push)

7.10 Addition:

The **off position** of **touch controls** for hobs shall be marked by the figure O and the on position by the figure I. If there is no **touch control** for the **hob**, this requirement applies to the **touch controls** for each **hob element**.

NOTE 101 If the same **touch control** is used for switching on and off, symbol 5010 of IEC 60417-1 may be used.

7.12 Addition:

If the **hob surface** is of glass-ceramic or similar material and protects **live parts**, the instructions shall include the substance of the following:

WARNING: If the surface is cracked, switch off the appliance to avoid the possibility of electric shock.

The instructions for **cooking ranges** and **ovens** shall include the substance of the following:

During use the appliance becomes hot. Care should be taken to avoid touching heating elements inside the oven.

If the instructions state that the **oven** can be used as a **grill** with the door open, they shall contain the substance of the following:

WARNING: Accessible parts may become hot when the grill is in use. Children should be kept away.

The instructions for **pyrolytic self-cleaning ovens** shall state that excess spillage must be removed before cleaning and shall specify which utensils can be left in the oven during cleaning.

If, for cleaning, the manufacturer instructs the user to set the controls to a position higher than for normal cooking purposes, the instructions shall state that under such conditions the surfaces may get hotter than usual and children should be kept away.

The instructions for **ovens** incorporating a fan with a guard that can be removed for cleaning shall state that the **oven** must be switched off before removing the guard and that, after cleaning, the guard must be replaced in accordance with the instructions.

The instructions for **ovens** provided with a facility to use a **temperature-sensing probe** shall include the substance of the following:

Only use the temperature probe recommended for this oven.

The instructions for **cooking ranges, hobs** and **ovens** shall state that a steam cleaner is not to be used.

The instructions for **induction hobs** shall include the substance of the following:

Metallic objects such as knives, forks, spoons and lids should not be placed on the hob surface since they can get hot.

The instructions for **hobs** incorporating a lid shall state that any spillage should be removed from the lid before opening. They shall also state that the hob surface should be allowed to cool before closing the lid.

The instructions for **hobs** incorporating halogen lamps shall warn the user not to stare at the hob elements.

The instructions for **hobs** incorporating a **pan detector** shall include the substance of the following:

After use, switch off the hob element by its control and do not rely on the pan detector.

If the appliance incorporates a lamp for illumination, and does not incorporate a switch providing full disconnection under overvoltage category III conditions, the instructions shall include the substance of the following:

WARNING: Ensure that the appliance is switched off before replacing the lamp to avoid the possibility of electric shock.

7.12.1 *Addition:*

The installation instructions for **cooking ranges** that are placed on the floor shall state that if the range is placed on a base, measures have to be taken to prevent the appliance slipping from the base.

NOTE 101 This statement is not required if the instructions specify that the range should not be placed on a base.

The installation instructions for appliances intended to be connected to the water mains shall include the maximum **rated water pressure** in megapascals.

7.12.3 *Addition:*

If a **cooking range** does not have a **supply cord**, the instructions shall state the type of cord to be used, taking into account the temperature of the rear surface of the appliance.

7.12.4 *Addition:*

The instructions for **built-in appliances** having separate control panels shall state that the control panel is only to be connected to the **heating units** specified in order to avoid a possible hazard.

7.15 *Addition:*

When it is not practical for the marking of **fixed appliances** to be visible after the appliance has been installed, the relevant information shall be included in the instructions or on an additional label that can be fixed near the appliance after installation.

NOTE 101 An example of such an appliance is a **built-in hob**.

The marking for the rated current of the fuse protecting a socket-outlet shall be placed on or near the socket-outlet.

7.101 Steam generators intended to be filled manually shall be marked with the maximum water level, which shall be visible during filling.

Compliance is checked by inspection.

7.102 The **cooking zone** of **hob surfaces** shall be identified by appropriate marking unless it is obvious.

Compliance is checked by inspection.

8 Protection against access to live parts

This clause of Part 1 is applicable except as follows.

8.1.2 Addition:

*Test probe 12 of IEC 61032 is applied without appreciable force to parts liable to be touched accidentally in normal use by a fork or similar pointed object. It shall not be possible to touch **live parts**.*

8.1.3 Modification:

*The use of test probe 41 instead of test probe B and test probe 13 is only allowed when **visibly glowing heating elements** are situated at the top of an **oven** or grilling compartment.*

9 Starting of motor-operated appliances

This clause of Part 1 is not applicable.

10 Power input and current

This clause of Part 1 is applicable except as follows.

10.1 Addition:

*The power input of **induction hob elements** is measured separately and the tolerances for **motor-operated appliances** apply.*

The contribution of a socket-outlet to the power input is considered to be 1 kW.

NOTE 101 Socket-outlets are not loaded during the test.

10.2 Addition:

*The current of **induction hob elements** is measured separately and the tolerances for **motor-operated appliances** apply.*

*The contribution of a socket-outlet to the current is considered to be 1 kW divided by the **rated voltage**.*

NOTE 101 Socket-outlets are not loaded during the test.

11 Heating

This clause of Part 1 is applicable except as follows.

11.1 Addition:

*For **cooking ranges and ovens**, compliance is also checked by the test of 11.101.*

11.2 Addition:

*For appliances intended to stand on the floor, a closed rectangular box is placed as close as possible to the free side of the appliance and against the rear wall of the test corner. The box is made of dull black painted plywood 10 mm thick. It has a width of 150 mm, its top being level with the **hob surface** and its front flush with the front surface of the appliance.*

*Appliances having a lid to cover the **hob surface** are tested with the lid open. Lids that can be removed without the aid of a **tool** are removed, unless the **hob element** cannot operate with the lid removed.*

***Temperature-sensing probes** are placed in the **oven** in any position likely to occur during normal use. They are not connected to control the **oven** temperature. The test for **pyrolytic self-cleaning ovens** is carried out with **temperature-sensing probes** in position, unless otherwise specified in the instructions.*

***Detachable parts** that are intended to be used to reduce the temperature of control panels are removed.*

NOTE 101 A retractable part is not considered to be a **detachable part**.

11.3 Addition:

*The temperature of the centre of the **oven** and the temperature rises of the surface of the rectangular box are determined using the thermocouples specified for the walls of the test corner.*

NOTE 101 If the magnetic field of an **induction hob element** unduly influences the results, the temperature rises can be determined using platinum resistances with twisted connecting wires or any equivalent means.

11.4 Addition:

***Induction hob elements** are supplied separately and operated as specified for **motor-operated appliances**.*

***Cooking ranges** are operated at 1,15 **rated power input** under **normal operation**. The supply voltage is measured when the power input has stabilized. This voltage is used to supply the **heating units** of the **cooking range** during the tests.*

11.6 Replacement:

***Combined appliances** are operated as specified for **heating appliances**.*

*If the temperature rise limits are exceeded in appliances incorporating motors, transformers or **electronic circuits**, and the power input is lower than the **rated power input**, the test is repeated with the appliance supplied at 1,06 times **rated voltage**.*

11.7 Replacement:

Appliances are operated for the duration specified in 11.7.101 to 11.7.106.

NOTE 101 Steady conditions are considered to be established if the temperature does not rise by more than 1 K in 15 min.

11.7.101 Induction hob elements are operated for 30 min. Other **hob elements** are operated for 60 min.

11.7.102 Ovens are operated for 60 min. If a rotating spit is provided, it is in operation.

NOTE 1 **Steam ovens** are operated in each mode of operation.

NOTE 2 Lamps in **ovens** are not manually switched on.

*If an appliance incorporates two **ovens** that can be energized simultaneously, they are tested together.*

***Pyrolytic self-cleaning ovens** are also operated under the cleaning conditions specified in the instructions for the maximum time allowed by the control or until steady conditions are established, whichever is shorter. During this period, other **heating units** that can be energized are operated under **normal operation**.*

11.7.103 Grills are operated for 30 min. However, **grills** having means to reduce the power input are operated for 15 min with their controls adjusted to the highest setting and then for 15 min at a setting which reduces the average power input by approximately 50 %.

***Grills** provided with a rotating spit are also operated with the spit rotating for 60 min.*

11.7.104 Griddles incorporating a thermal control are operated until steady conditions are established. Other **griddles** are operated for 30 min after the centre of the heating surface attains a temperature of 275 °C.

11.7.105 Warming drawers and similar compartments are operated for 30 min.

11.7.106 For cooking ranges, combinations of **heating units** that can be energized simultaneously are tested together for the durations specified in 11.7.101 to 11.7.105, **heating units** that have a test duration of 30 min being operated for the last 30 minutes of the test.

NOTE For example, the sequence of tests for a **cooking range** incorporating a **grill** in the **oven** and a rotating spit is as follows:

- operation of the **hob** and **oven** and, if possible, with the spit rotating, for 60 min;
- cooling down to approximately room temperature;
- operation of the **hob** for 60 min, the **grill** being operated simultaneously for the last 30 minutes;
- cooling down to approximately room temperature;
- operation of the **hob** and **grill** with the spit rotating, for 60 min.

11.7.107 *If the appliance incorporates a socket-outlet, an appropriate plug complying with IEC 60083 is engaged. The plug is connected to a 1 kW resistive load by means of an ordinary polyvinyl chloride sheathed flexible cord (code designation 60227 IEC 53) having a cross-sectional area of 0,75 mm². The temperature rise of the plug is determined during the last 30 min of the test.*

11.8 Modification:

Instead of the temperature rises stated in Table 3 for wood, the following applies.

Temperature rises of the floor and walls of the test corner, wooden cabinets and the rectangular box shall not exceed the following values:

- | | |
|---|------|
| – appliances intended to stand on a table | 65 K |
| – grills | 75 K |
| – other appliances | 70 K |

*The temperature rise of parts of the underside of **built-in hobs**, accessible to a 75 mm diameter probe having a hemispherical end, shall not exceed 70 K unless the instructions specify that a board is to be installed underneath the **hob**.*

Addition:

*The temperature rise of handles of inner glass doors, grill pans, **temperature-sensing probes** and rotating parts in **ovens** or **grills** is not limited.*

*During the additional test for **pyrolytic self-cleaning ovens**, the temperature rise of the surface of knobs, handles and levers shall not exceed the following values:*

- | | |
|------------------------------------|------|
| – metal | 55 K |
| – porcelain or vitreous material | 65 K |
| – moulded material, rubber or wood | 80 K |

The temperature rises of knobs, handles and levers associated with functions that cannot be performed during the cleaning operation are not determined.

*The temperature rise limits of motors, transformers and components of **electronic circuits**, including parts directly influenced by them, may be exceeded when the appliance is operated at 1,15 times **rated power input**.*

The temperature rise of the plug, measured 2 mm below the surface at the centre of the engagement face, shall not exceed 45 K.

11.101 Cooking ranges and ovens are placed as specified in 11.2. However, appliances intended to stand on the floor are positioned with their backs against one of the walls of the test corner and away from the other wall. A rectangular box as specified in 11.2 is placed against one of the sides of the appliance. The appliance is supplied at **rated voltage** and operated under **normal operation**.

*All **heating units**, other than **grills**, that can be connected to the supply mains at the same time during normal use are switched on.*

***Ovens** are operated without accessories. The mean temperature in the centre of the **oven** is maintained at 200 °C ± 4 °C.*

***Hob elements** and **griddles** are operated in accordance with 11.7.*

Warming drawers and similar compartments are operated with the controls adjusted to the highest setting.

The appliance is operated for 60 min or until steady conditions are established, whichever is shorter.

Temperature rises of the front and side surfaces are measured using the probe of Figure 104. The probe is applied with a force of $4\text{ N} \pm 1\text{ N}$ to the surface in such a way that the best possible contact between the probe and the surface is ensured.

NOTE 1 Any measuring instrument giving the same results as the probe may be used.

Temperature rises are not measured on

- surfaces that are inaccessible to a 75 mm diameter probe having a hemispherical end, unless they are protected by a **detachable guard**;
- surfaces of **cooking ranges** that are within 25 mm below the level of the **hob surface** or are above the **hob surface**;
- small parts such as **oven** vents, hinges and trim where the width of the **accessible surface** is less than 10 mm;
- surfaces within 10 mm of the edge of the **oven** door.

During the test, the temperature rise of surfaces shall not exceed the values specified in Table 102.

Table 102 – Temperature rise limits for accessible surfaces

Surface	Temperature rise K	
	Front surfaces of oven doors	Other parts
Metal and painted metal	45	60
Vitreous-enamelled metal	50	65
Glass and ceramic	60	80
Plastic having a thickness exceeding 0,3 mm	80	100

NOTE 1 The temperature rise limit of 100 K also applies for plastic material having a metal finish of thickness less than 0,1 mm.

NOTE 2 When the thickness of the plastic coating does not exceed 0,3 mm, the temperature rise limits of the supporting material apply.

NOTE 2 If the door is protected by a guard, the temperature rises specified for the front surface of **oven** doors apply to the guard.

However, for **oven** doors the temperature rise limits specified for other parts apply to

- parts protected by a **detachable guard**;
- those parts of the door of **built-in ovens** situated more than 850 mm above the floor after installation of the **oven**;
- **ovens** intended to be used on a working surface.

If the **oven** can be used for grilling and the instructions state that for grilling the door should be closed, the test is repeated but with the **oven** operating in the grilling mode with the controls set according to the instructions. The **grill** is operated for 30 min in accordance with 11.7.103. However, if the **oven** has a rotating spit, the duration of the test is 60 min, with the controls set to give the most unfavourable conditions specified in the instructions. The measurements are only carried out on surfaces for which temperature rises for the front surface of **oven** doors apply.

12 Void

13 Leakage current and electric strength at operating temperature

This clause of Part 1 is applicable except as follows.

13.1 Addition:

*If a **grill** is incorporated in the **oven**, either the **oven** or the **grill** is operated, whichever is more unfavourable.*

*For **hobs**, the tests are carried out with a vessel filled as specified in 3.1.9.101 placed on each **cooking zone**.*

***Induction hob elements** are tested as specified for **motor-operated appliances**.*

13.2 Modification:

After the appliance has been operated for the duration specified in 11.7, the controls are adjusted to their highest setting and the leakage current is measured within 10 s of it attaining its highest value.

*For **stationary class I appliances**, the leakage current shall not exceed the following values:*

- *for appliances with heating elements that are detachable or can be switched off separately* *1 mA, or 1 mA kW power input for each element with a limit of 10 mA, whichever is higher. If the appliance has more than three **heating units**, only 75 % of the measured leakage current is taken into account;*
- *for other appliances* *1 mA, or 1 mA per kW **rated power input** with a limit of 10 mA, whichever is higher.*

*If there is earthed metal between **live parts** and the surface of glass-ceramic or similar material of **hobs**, the leakage current is measured between **live parts** and each vessel in turn connected to the earthed metal. If there is no earthed metal, the leakage current, measured between **live parts** and each of the vessels in turn, shall not exceed 0,25 mA.*

13.3 Addition:

*If there is earthed metal between **live parts** and the surface of glass-ceramic or similar material of **hobs**, a test voltage of 1 000 V is applied between **live parts** and all the vessels connected to the earthed metal. If there is no earthed metal, a test voltage of 3 000 V is applied between **live parts** and the vessels.*

14 Transient overvoltages

This clause of Part 1 is applicable.

15 Moisture resistance

This clause of Part 1 is applicable except as follows.

15.2 Addition:

Cooking ranges and hobs are positioned so that the **hob surface** is horizontal. A vessel having the largest diameter shown in Figure 101, which does not exceed the diameter of the **cooking zone**, is completely filled with water containing approximately 1 % NaCl and positioned centrally over the **cooking zone**. A further quantity of 0,5 l of the solution is poured steadily into the vessel over a period of 15 s. The test is carried out on each **cooking zone** in turn, after removing any residual solution from the appliance.

For **hob elements** incorporating a switch or a thermal control, 0,02 l of the saline solution is poured over the **hob element** so that it flows over the switch or control. A vessel is then placed on the **hob element** to depress any movable part. If controls are mounted below the **hob surface**, 0,5 l of the saline solution is poured steadily over the top of the **hob** near the controls over a period of 15 s. If the controls are mounted in the **hob surface**, the saline solution is poured over them.

For **hobs** having ventilating openings in the **hob surface**, 0,2 l of the saline solution is poured steadily through a funnel onto the ventilating openings. The funnel has an outlet diameter of 8 mm and is positioned vertically with the outlet 200 mm above the **hob surface**. The funnel is positioned above the ventilating openings so that the solution enters the appliance in the most unfavourable way.

NOTE 101 If the opening is protected, the funnel is positioned so that the solution falls onto the **hob surface** as close as possible to the opening.

NOTE 102 Care is to be taken to ensure that the saline solution is not poured over controls located close to ventilating openings.

For **ovens and grills**, 0,5 l of the saline solution is poured over the floor of the **oven** or grilling compartment.

For appliances having a drip tray or similar receptacle, the receptacle is filled with the saline solution. A further quantity of the solution, equal to 0,01 l per 100 cm² of the area of the top surface of the receptacle, is poured onto the receptacle through openings in the **hob surface**. However, the total quantity of solution shall not exceed 3 l.

For **hobs** having a lid, 0,5 l of the saline solution is poured uniformly over the closed lid. When the solution has run off, the surface is dried and a further 0,125 l of the solution is poured steadily from a height of approximately 50 mm onto the centre of the lid over a period of 15 s. The lid is then opened as in normal use.

Steam generators intended to be connected to the water mains are supplied at **rated water pressure**. Control devices for the supply of water are held open. Water is allowed to flow for 1 min after the first evidence of overflow, unless the inflow stops automatically.

NOTE 103 Only one device is held open at a time.

15.101 Temperature-sensing probes shall be constructed so that their insulation is not affected by water.

Compliance is checked by the following test.

The probe is completely immersed in water containing approximately 1 % NaCl and having a temperature of 20 °C ± 5 °C. The water is heated to the boiling point in approximately 15 min.

The probe is then removed from the boiling water and immersed in water having a temperature of 20 °C ± 5 °C for 30 min.

This procedure is carried out five times after which the probe is removed from the water. All traces of liquid are then removed from the surface.

The probe shall then withstand the leakage current test of 16.2.

NOTE **Detachable temperature-sensing probes** are not connected to the appliance for this test. **Non-detachable temperature-sensing probes** are tested in the oven, the probe being immersed as much as possible.

16 Leakage current and electric strength

This clause of Part 1 is applicable except as follows.

16.1 Addition:

*For **hobs**, the tests are carried out with a vessel filled as specified in 3.1.9.101 placed on each **cooking zone**.*

***Induction hob elements** are tested as specified for **motor-operated appliances**.*

16.2 Modification:

*For **stationary class I appliances**, the leakage current shall not exceed the following values:*

- *for appliances with heating elements that are detachable or can be switched off separately* *1 mA, or 1 mA per kW power input for each element with a limit of 10 mA, whichever is higher. If the appliance has more than three **heating units**, only 75 % of the measured leakage current is taken into account;*
- *for other appliances* *1 mA, or 1 mA per kW **rated power input** with a maximum of 10 mA, whichever is higher.*

NOTE 101 If the **oven** incorporates a **grill**, or if the appliance incorporates a means to limit the total power input, only the leakage current of those elements that can be switched on at the same time is taken into consideration.

*If there is earthed metal between **live parts** and the surface of glass-ceramic or similar material of **hobs**, the leakage current is measured between **live parts** and each vessel in turn connected to the earthed metal. If there is no earthed metal, the leakage current, measured between **live parts** and each of the vessels in turn, shall not exceed 0,25 mA.*

16.3 Addition:

*If there is earthed metal between **live parts** and the surface of glass-ceramic or similar material of **hobs**, a test voltage of 1 250 V is applied between **live parts** and all the vessels connected to the earthed metal. If there is no earthed metal, a test voltage of 3 000 V is applied between **live parts** and the vessels.*

17 Overload protection of transformers and associated circuits

This clause of Part 1 is applicable.

18 Endurance

This clause of Part 1 is not applicable.

19 Abnormal operation

This clause of Part 1 is applicable except as follows.

19.1 Addition:

*For **induction hobs**, compliance is also checked by the tests of 19.101 and 19.102, but 19.4 is not applicable.*

***Temperature-sensing probes** are placed in the **oven** in any position likely to occur during normal use except that they are not connected to control the **oven** temperature.*

19.2 Addition:

***Hob elements** are operated without a vessel, **pan detectors** being rendered inoperative. **Oven** doors are open or closed, whichever is more unfavourable. **Hob** lids are closed unless the **hob elements** are interlocked with the lid or an indicator lamp shows that a **hob element** is switched on.*

NOTE 101 A lamp that is switched on and off by a **thermostat** or energy regulator does not show that the **hob element** is switched on.

*For appliances incorporating more than one **heating unit**, the test is only carried out with the **heating unit** resulting in the most unfavourable conditions, its control being adjusted to the highest setting. If the appliance incorporates an **oven** without an indicator lamp to show that the **oven** is switched on, the oven is also operated, its control being adjusted to the highest setting.*

NOTE 102 A lamp used for illuminating the **oven**, visible through the door and which is automatically switched on and off together with the **oven**, is considered to be an indicator lamp.

*If an **induction hob element** has a metallic lid, a force of 30 N is applied to the closed lid in the most unfavourable place by means of test probe B of IEC 61032.*

***Pyrolytic self-cleaning ovens** are also operated under cleaning conditions, motors that operate during cleaning being switched off or disconnected in turn.*

NOTE 103 Examples are motors of fans and timers.

***Induction hob elements** are operated under the conditions of Clause 11 but with empty vessels, the controls being adjusted to the highest setting.*

***Steam ovens** are operated without water.*

*Doors of separate grill compartments incorporated in a **cooking range** are open or closed, whichever is more unfavourable.*

19.9 Not applicable.

19.11.2 Addition:

*During simulation of the fault conditions, it shall be possible to switch off any energized **hob element**.*

The fault conditions are also simulated with all **hob elements** switched off, the appliance being supplied at **rated voltage**. If a **pan detector** is incorporated, a suitable vessel is placed on the **cooking zone**.

The **hob elements** shall not become energized.

19.13 Addition:

The temperature rise limit of 150 K also applies to wooden cabinets and rectangular boxes.

The temperature in the centre of **pyrolytic self-cleaning ovens** during the test of 19.4 shall not exceed 425 °C whenever the **oven door** can be opened.

The temperature rise of the windings of **induction hob elements** shall not exceed the values specified in 19.7.

The electric strength test of **induction hob elements** is carried out immediately after switching off the appliance.

19.101 Induction hob elements are supplied at **rated voltage** and operated with a steel disc placed on the centre of the **cooking zone**. The disc has a thickness of 6 mm and the smallest diameter, rounded up to the nearest centimetre, that allows the **hob element** to operate.

19.102 Induction hob elements are supplied at **rated voltage** and operated under **normal operation** but with thermal controls short-circuited.

The temperature rise of the oil shall not exceed 270 K.

20 Stability and mechanical hazards

This clause of Part 1 is applicable except as follows.

20.101 Cooking ranges and **ovens** shall have adequate stability when the open door is subjected to a load.

Compliance is checked by the following test.

Appliances with horizontally hinged doors are placed on a horizontal surface and a mass is placed on the centre of the open door. For non-rectangular doors, the mass is placed on the part farthest from the hinge where it could be placed in normal use.

For appliances normally placed on the floor the mass is

- 22,5 kg, for **oven doors**;
- 7 kg, for other doors.

For appliances normally placed on a table, the mass is 7 kg.

For appliances normally placed on the floor and having vertically hinged doors, a mass of 15 kg is placed in the most unfavourable position on the open door.

NOTE 1 The **oven** shelves are placed in the most unfavourable position.

NOTE 2 A sandbag may be used for the load.

NOTE 3 For an appliance having more than one door, the test is carried out on each door separately.

*For **cooking ranges** incorporating a storage compartment adjacent to the oven and in which the shelves are pulled out simultaneously, the shelves are also loaded. The shelves are placed in the most unfavourable position and loaded with a uniformly distributed mass. The mass in grams is equal to the area of the shelf in square centimetres multiplied by*

- 7,5, if the free height above the shelf does not exceed 20 cm;
- 15, if the free height above the shelf exceeds 20 cm.

The appliance shall not tilt.

NOTE 4 Damage and deformation of doors and hinges are neglected.

21 Mechanical strength

This clause of Part 1 is applicable except as follows.

Addition:

If the appliance has glass doors, three blows are applied to the centre of the glass, the door being in the closed position. If the door has horizontal hinges, the blows are also applied to the inside of the door when it is in the open position.

The glass shall not fracture.

*If the appliance incorporates **visibly glowing heating elements** enclosed in glass tubes, the blows are applied to the tubes as mounted in the appliance if they are*

- located at the top of the **oven** and accessible to test probe 41 of IEC 61032;
- located elsewhere in the **oven** and accessible to test probe B of IEC 61032.

*For **hob surfaces** of glass-ceramic or similar material, three blows are applied to parts of the surfaces that are not exposed to impacts during the test of 21.102, the impact energy being increased to $0,70 \text{ J} \pm 0,05 \text{ J}$. The blows are not applied to surfaces within 20 mm of knobs.*

NOTE 101 If the **hob surface** comprises a single piece of material except for the outer frame, this test is not carried out.

NOTE 102 Additional support is not provided for the door in the open position.

*After the test, **temperature-sensing probes** are subjected to one cycle of the procedure described in 15.101 and shall then withstand the leakage current test of 16.2.*

21.101 Oven shelves and their supports shall have adequate mechanical strength.

Compliance is checked by the following test.

*A vessel filled with sand or shot is placed on the **oven** shelf. The total mass in kilograms is equal to 220 times the volume of the useful **oven** space in cubic metres, or 24 kg, whichever is less.*

*The shelf, with the vessel placed centrally on it, is inserted into the **oven** and moved as close as possible to one of the side walls. It is left in this position for 1 min and then withdrawn. It is then reinserted, moved as close as possible to the other sidewall and left for 1 min.*

The test is repeated for each supporting position of the shelf. The shelf and supports shall show no distortion impairing their further use and the shelf shall not fall from the supports.

21.102 Hob surfaces of glass-ceramic or similar material shall withstand the stresses liable to occur in normal use.

Compliance is checked by the following test.

*Each **hob element** is operated at **rated power input** with its control adjusted to the maximum setting. **Induction hob elements** are operated as specified in Clause 11. When steady conditions are established, the **hob element** is switched off and a loaded vessel is dropped flat 10 times from a height of 150 mm onto the **cooking zone**.*

The vessel has a flat copper or aluminium base over a diameter of 120 mm ± 10 mm, its edges being rounded with a radius of at least 10 mm. It is uniformly filled with at least 1,3 kg of sand or shot so that the total mass is 1,80 kg ± 0,01 kg.

*After subjecting each **cooking zone** in turn to this impact, the vessel is removed and all **hob elements** are operated simultaneously until steady conditions are established.*

*A quantity of $1^{+0,1}_0$ l of water having a temperature of 15 °C ± 5 °C and containing approximately 1 % NaCl is poured steadily over the **hob surface**. The appliance is then disconnected from the supply. After 15 min all excess water is removed and the appliance allowed to cool to approximately room temperature. The same quantity of the saline solution is poured over the **hob surface** after which excess water is removed again.*

*The **hob surface** shall not crack and the appliance shall withstand the electric strength test of 16.3.*

21.103 Temperature-sensing probes shall be constructed so that they are not damaged when trapped in the **oven** door.

Compliance is checked by the following test.

*The probe is connected as in normal use and the sensing part or cord allowed to rest in any position likely to occur. The **oven** door is closed against the sensing part or cord and a force of 90 N is applied to the door in the most unfavourable place for 5 s.*

The probe shall then comply with 8.1, 15.101 and Clause 29.

NOTE The **oven** is not operated during this test.

21.104 Glass panels of horizontally hinged **oven** doors shall withstand the thermal shock liable to occur in normal use.

Compliance is checked by the following test.

The appliance is operated as specified in Clause 11. The door is then opened and 0,2 l of water having a temperature of 15 °C ± 5 °C is poured within 5 s onto the centre of the glass panel.

The glass shall not fracture.

NOTE The test is not carried out after the cleaning cycle of **pyrolytic self-cleaning ovens**.

22 Construction

This clause of Part 1 is applicable except as follows.

22.21 Addition:

NOTE 101 Magnesium oxide and mineral ceramic fibres used for the electrical insulation of heating elements are not considered to be hygroscopic materials.

22.101 Hobs shall be constructed so that **hob elements** are prevented from rotating about a vertical axis and are adequately supported in all positions of adjustment of their supports.

NOTE If a **hob element** is clamped by a nut on a central stud, an additional means is required to prevent its rotation.

Hobs with detachable hob elements shall be constructed so that damage is unlikely to occur while the **hob elements** are being removed or replaced.

Compliance is checked by inspection.

22.102 Timers intended to delay the operation of a heating element shall not control a radiant **grill**, unless the **grill** is thermally controlled and incorporated in an **oven** or other compartment.

Compliance is checked by inspection.

22.103 Oven vents shall be constructed so that any moisture or grease discharged through them cannot affect **clearances** and **creepage distances** between **live parts** and other parts of the appliance.

Compliance is checked by inspection.

22.104 Steam ovens shall be constructed so that steam vents and ducts are unlikely to become blocked during normal use.

Compliance is checked by inspection.

22.105 Built-in ovens shall only be vented through the front, unless provision is made for venting through a duct.

Compliance is checked by inspection.

22.106 Grills shall be constructed so that grill pans can be easily positioned without jamming.

The grill pans shall not fall from the support when moved sideways.

Compliance is checked by inspection and by manual test.

22.107 Pyrolytic self-cleaning ovens shall switch off automatically at the end of the cleaning process and require a manual operation to start another cleaning cycle.

Compliance is checked by inspection.

22.108 Pyrolytic self-cleaning ovens shall be constructed so that opening and closing of the door does not impair the interlock system or damage the door seal.

Compliance is checked by the following test.

The door is opened at least 10 cm and is then closed by applying a force of 90 N to the handle. This operation is carried out 5 000 times. Every 1 000 cycles, the interlock system for the self-cleaning function is operated.

After the test, the interlock system shall be fit for further use and the door seal shall not be damaged.

22.109 Pyrolytic self-cleaning ovens shall incorporate an interlock so that access to the **oven** cannot be gained when the temperature in the centre of the **oven** exceeds 350 °C, even if the interlock is defective.

Compliance is checked by inspection and by the following test.

*The **oven** is supplied at **rated voltage** and operated under cleaning conditions, after which it is allowed to cool. While the temperature in the centre of the **oven** exceeds 350 °C, a force of 90 N is applied to levers and handles, and a torque of 2 Nm is applied to rotary knobs. It shall not be possible to open the door.*

The test is repeated with any defect that may be expected in normal use applied to the interlock system, including interruption of the supply, only one defect being simulated at a time.

NOTE 1 Examples of defects are the breakage of a spring, or a gravity-operated part failing to drop into position.

NOTE 2 Fault conditions applied during the tests of Clause 19 are not repeated.

22.110 Pyrolytic self-cleaning ovens shall be constructed so that ignitable gases cannot be discharged through vents during the cleaning process.

Compliance is checked by the following test.

*A mixture of 30 g of gravy and 15 g of hydrogenated oil shortening is spread evenly over the interior of the **oven**, including the door. The **oven** is operated for 3 h at the maximum setting of the **thermostat**.*

NOTE 1 The gravy consists of two-thirds by mass of beef extract and one-third water.

*The **oven** is then operated under cleaning conditions and attempts are made to ignite gases that may be discharged through vents by bursts of sparks. The sparks are approximately 3 mm long, each spark having an energy of at least 0,5 J.*

*The sparks are applied when the temperature in the centre of the **oven** reaches 300 °C and at each subsequent temperature rise of 50 K.*

NOTE 2 The electrodes used to produce the sparks are moved in and around the vents through which gases may be discharged.

There shall be no continuous burning of gases.

*If the **oven** incorporates a heating element intended to eliminate smoke, the test is repeated with this heating element disconnected if the temperature in the centre of the **oven** exceeds 450 °C under cleaning conditions.*

22.111 Pyrolytic self-cleaning ovens shall be constructed so that there is no risk of emission of flames during the cleaning process.

Compliance is checked by the following test.

*A suitable vessel containing 100 g of salt-free butter is placed on the centre of the **oven** floor.*

The electrodes of a spark generator are positioned approximately 7,5 cm above the surface of the butter.

*The **oven** is then operated under cleaning conditions and bursts of sparks are produced. The sparks are approximately 3 mm long, each spark having an energy of at least 0,5 J. The sparks are generated when the temperature in the centre of the **oven** reaches 300 °C and at each subsequent temperature rise of 50 K.*

There shall be no emission of flames through door seals, vents or other openings.

22.112 Hobs shall be constructed so that hinged lids cannot close accidentally.

Compliance is checked by inspection and by manual test.

NOTE This requirement may be met if the hinge incorporates a click stop or similar means, or if the lid can be opened through an angle of at least 100°, when the appliance is placed against a wall.

22.113 Hobs shall be constructed so that inadvertent operation of **touch controls** is unlikely if this could give rise to a hazardous situation due to

- spillage of liquids, including that caused by a vessel boiling over;
- a damp cloth placed on the control panel.

*Compliance is checked by the following test, the appliance being supplied at **rated voltage**. The test is carried out with each **hob element** energized in turn and then without energizing any **hob elements**.*

Sufficient water to completely cover the control panel to a depth not exceeding 2 mm, with a minimum of 140 ml, is poured steadily over the control panel so that bridging occurs between combinations of touch pads.

A cloth having a mass between 140 g/m² and 170 g/m², and dimensions approximately 400 mm x 400 mm, is folded four times into a square pad, saturated with water and placed over the control panel in any position.

*There shall be no operation of any **hob element** for longer than 10 s.*

*During the test, it shall be possible to switch off the energized **hob element** by operating the **touch controls**, unless it switches off automatically.*

22.114 Hobs having **touch controls** shall require at least two manual operations to switch on a **hob element** but only one operation to switch it off. However, additional **hob elements** may be switched on by a single manual operation. In this case, 1 min after all the **hob elements** have been switched off, two manual operations are required to re-energize one **hob element**.

NOTE Touching the contact surface at the same point twice is not considered to be two operations.

Hobs having **touch controls** shall incorporate visual means to indicate when each **hob element** is energized.

Compliance is checked by inspection and by manual test.

22.115 Induction hob elements, and other **hob elements** incorporating a **pan detector**, shall be constructed so that the **hob element** can only be operated when a vessel is placed on the **cooking zone**.

*Compliance is checked by the following test, the appliance being supplied at **rated voltage**.*

*An iron bar 2 mm thick having dimensions approximately 100 mm x 20 mm is placed in the most unfavourable position on each **cooking zone** in turn. The controls are adjusted to their highest setting.*

*For **induction hob elements**, the temperature rise of the bar shall not exceed 35 K. Other **hob elements** shall not operate.*

22.116 Hob elements incorporating a **pan detector** shall be constructed so that the **hob element** is not switched on by the vessel if it has been removed for more than 10 min.

Compliance is checked by manual test.

22.117 In appliances incorporating a **pan detector**, a signal lamp shall indicate when the control for the **hob element** is not switched to the **off position**.

Compliance is checked by inspection.

22.118 It shall not be possible to operate a **grill** while the plug of a **supply cord** is engaged in a socket-outlet located directly above the door.

Compliance is checked by inspection and by manual test.

22.119 Cooking ranges incorporating a retractable deflector to prevent excessive temperatures on control knobs shall be constructed so that the user is unlikely to touch hot surfaces of the deflector when operating the controls.

Compliance is checked by measuring the distance between the deflector in its extended position and that part of the control knob touched in normal use. It shall be at least 25 mm, or the temperature rise of those parts within 25 mm of the knob shall not exceed the limits for handles, knobs, grips and similar parts held for short periods only, as specified in Table 3.

23 Internal wiring

This clause of Part 1 is applicable except as follows.

23.3 Addition:

The requirement also applies if parts of a **cooking range** are folded onto the **hob surface**, or separated from their normal position, for transportation purposes.

24 Components

This clause of Part 1 is applicable except as follows.

24.1.3 Addition:

*Switches controlling **hob elements** are subjected to 30 000 cycles of operation.*

NOTE This does not apply to switches having only one closed position.

24.1.4 Addition:

- *energy regulators*
 - *for automatic action* 100 000
 - *for manual action* 10 000
- **self-resetting thermal cut-outs**
 - *for heating elements of glass-ceramic **hobs*** 100 000
 - *for heating elements of other **hobs*** 10 000
- **thermostats controlling the cleaning process in pyrolytic self-cleaning ovens** 3 000

24.101 Thermostats and energy regulators incorporating an **off position** shall not switch on as a result of variations in ambient temperatures.

Compliance is checked by the following test that is carried out on three samples of the control.

*The control, adjusted to the **off position**, is placed for 2 h in an ambient temperature of -20_{-5}^0 °C, and then at*

- *t °C, where t is the temperature according to the T-marking;*
- *55 °C, for controls without a T-marking.*

*During the test, the **off position** shall be maintained.*

A test voltage of 500 V is applied across the contacts for 1 min. No breakdown shall occur.

24.102 Socket-outlets incorporated in **cooking ranges** shall be single-phase, incorporate an earthing contact and have a rated current not exceeding 16 A. Both poles shall be protected by fuses or miniature circuit-breakers having a rated current not exceeding the rated current of the socket-outlet. They shall be placed behind a **non-detachable cover**. However, if the **cooking range** is intended to be permanently connected to fixed wiring or is fitted with a polarized plug, the neutral pole need not be protected.

Compliance is checked by inspection.

NOTE 1 The actuating member of miniature circuit-breakers may be accessible.

NOTE 2 A **non-detachable cover** is not required if fuses become accessible after opening a drawer or other compartment.

25 Supply connection and external flexible cords

This clause of Part 1 is applicable except as follows.

25.3 *Addition:*

Hobs, built-in ranges and built-in ovens may be connected to the supply mains before the appliance is installed.

25.14 *Addition:*

*For **temperature-sensing probes**, the total number of flexings is 5 000. Probes with circular-section cords are turned through 90° after 2 500 flexings.*

26 Terminals for external conductors

This clause of Part 1 is applicable.

27 Provision for earthing

This clause of Part 1 is applicable.

28 Screws and connections

This clause of Part 1 is applicable.

29 Clearances, creepage distances and solid insulation

This clause of Part 1 is applicable except as follows.

29.2 *Addition:*

The microenvironment is pollution degree 3 unless the insulation is enclosed or located so that it is unlikely to be exposed to pollution during normal use of the appliance.

29.3 *Addition:*

This requirement does not apply to the sheath of a **visibly glowing heating element** inaccessible to test probe 41 of IEC 61032.

30 Resistance to heat and fire

This clause of Part 1 is applicable except as follows.

30.2 *Addition:*

*For **grills and griddles** that do not incorporate a timer, 30.2.2 is applicable. For other appliances, 30.2.3 is applicable.*

31 Resistance to rusting

This clause of Part 1 is applicable.

32 Radiation, toxicity and similar hazards

This clause of Part 1 is applicable except as follows.

32.101 Pyrolytic self-cleaning ovens shall be constructed so that carbon monoxide is not discharged in hazardous quantities during cleaning.

Compliance is checked by the following test.

*Twice the quantity of the mixture specified in 22.110 is spread evenly over the interior of the **oven**, including the door. The **oven** is supplied at **rated voltage** and operated for 3 h at the maximum setting of the **thermostat**.*

*The **oven** is then allowed to cool to room temperature and placed in a closed test room having a volume of 20 m³ to 25 m³, in which the air is circulated by a low-speed fan. The **oven** is operated under cleaning conditions and the concentration of carbon monoxide is measured 1 m above the centre of the floor.*

The concentration of carbon monoxide shall not exceed 0,015 %.

*If the **oven** incorporates a heating element intended to eliminate smoke, the test is repeated with this heating element disconnected, unless the cleaning process can only be performed when the heating element is in circuit.*

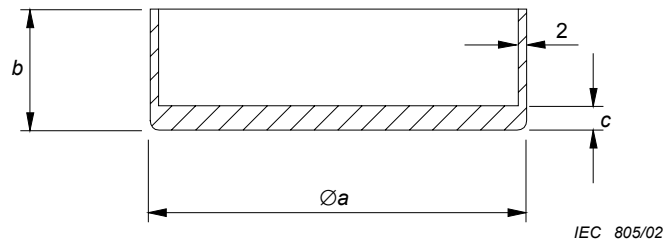

Dimensions in millimetres

Diameter of cooking zone mm	Approximate dimension		
	a mm	b mm	c mm
≤ 110	110	140	8
>110 ≤145	145	140	8
>145 ≤180	180	140	9
>180 ≤220	220	120	10
>220 ≤300	300	100	10

NOTE The maximum concavity of the base of the vessel is to be not more than 0,05 mm. The base of the vessel is not to be convex.

Figure 101 – Vessel for testing hob elements

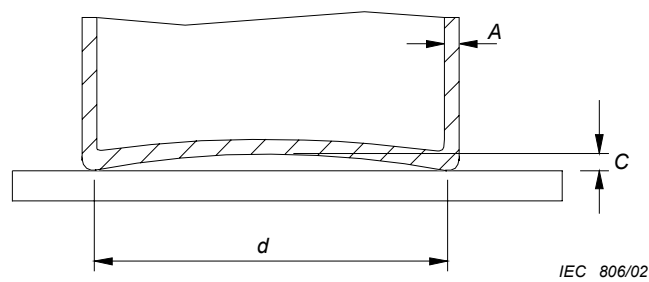
**Key**

A Base and wall thickness, $2 \text{ mm} \pm 0,5 \text{ mm}$

C Maximum concavity

d Diameter of the flat area of the base

NOTE The vessel is made of low carbon steel having a maximum carbon content of 0,08 %. It is cylindrical without metallic handles or protrusions. The diameter of the flat area of the base of the vessel is to be at least the diameter of the **cooking zone**. The maximum concavity of the base of the vessel is $0,006 d$. The base of the vessel is not to be convex.

Figure 102 – Vessel for testing induction hob elements

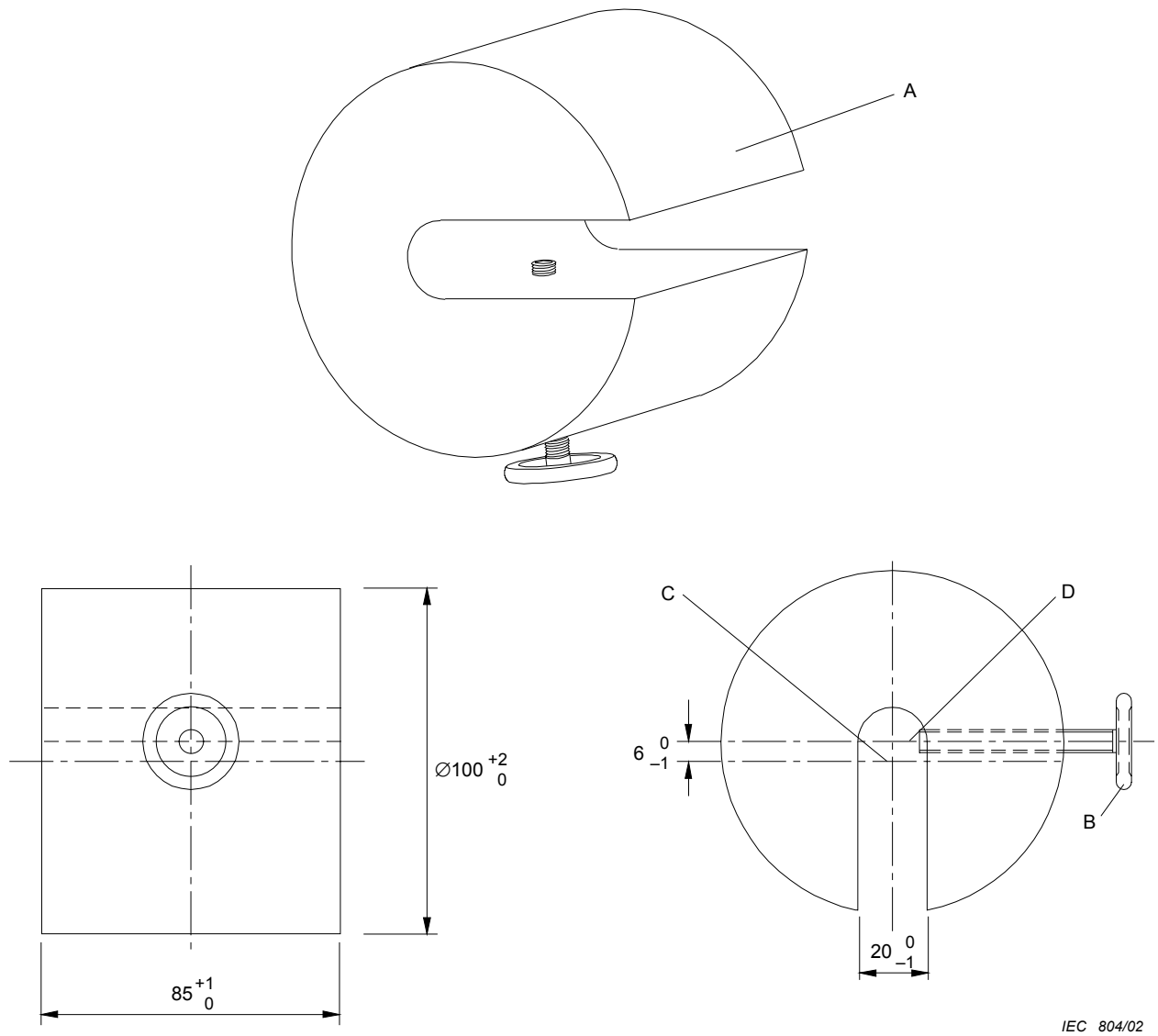

IEC 804/02

Dimensions in millimetres

Key

- A Load, mass approximately 4,5 kg
- B Fixing screw
- C Axis of load
- D Axis of fixing screw

NOTE The load is positioned on the rotary spit so that the fixing screw contacts the diameter of the spit.

Figure 103 – Load for testing rotating spits

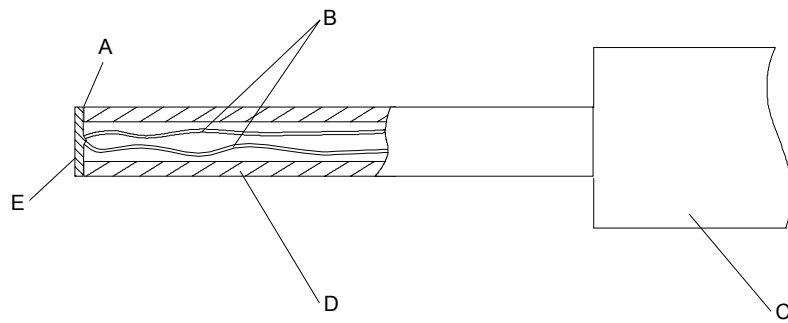

IEC 807/02

Key

- A Adhesive
- B Thermocouple wires 0,3 mm diameter to IEC 60584-1 Type K (chrome alumel)
- C Handle arrangement permitting a contact force of $4 \text{ N} \pm 1 \text{ N}$
- D Polycarbonate tube: inside diameter 3 mm, outside diameter 5 mm
- E Tinned copper disc: 5 mm diameter, 0,5 mm thick

NOTE The contact face of the disc is to be flat.

Figure 104 – Probe for measuring surface temperatures

Annexes

The annexes of Part 1 are applicable.

Bibliography

The bibliography of Part 1 is applicable except as follows.

Addition:

IEC 60335-2-9, *Household and similar electrical appliances – Safety – Part 2-9: Particular requirements for grills, toasters and similar portable cooking appliances*

IEC 60335-2-25, *Household and similar electrical appliances – Safety – Part 2-25: Particular requirements for microwave ovens including combination microwave ovens*



Standards Survey

The IEC would like to offer you the best quality standards possible. To make sure that we continue to meet your needs, your feedback is essential. Would you please take a minute to answer the questions overleaf and fax them to us at +41 22 919 03 00 or mail them to the address below. Thank you!

Customer Service Centre (CSC)

International Electrotechnical Commission

3, rue de Varembé

1211 Genève 20

Switzerland

or

Fax to: **IEC/CSC** at +41 22 919 03 00

Thank you for your contribution to the standards-making process.

A Prioritaire

Nicht frankieren
Ne pas affranchir



Non affrancare
No stamp required

RÉPONSE PAYÉE

SUISSE

Customer Service Centre (CSC)

International Electrotechnical Commission

3, rue de Varembé

1211 GENEVA 20

Switzerland



Q1 Please report on **ONE STANDARD** and **ONE STANDARD ONLY**. Enter the exact number of the standard: (e.g. 60601-1-1)

.....

Q2 Please tell us in what capacity(ies) you bought the standard (tick all that apply). I am the/a:

- purchasing agent
- librarian
- researcher
- design engineer
- safety engineer
- testing engineer
- marketing specialist
- other.....

Q3 I work for/in/as a: (tick all that apply)

- manufacturing
- consultant
- government
- test/certification facility
- public utility
- education
- military
- other.....

Q4 This standard will be used for: (tick all that apply)

- general reference
- product research
- product design/development
- specifications
- tenders
- quality assessment
- certification
- technical documentation
- thesis
- manufacturing
- other.....

Q5 This standard meets my needs: (tick one)

- not at all
- nearly
- fairly well
- exactly

Q6 If you ticked NOT AT ALL in Question 5 the reason is: (tick all that apply)

- standard is out of date
- standard is incomplete
- standard is too academic
- standard is too superficial
- title is misleading
- I made the wrong choice
- other

Q7 Please assess the standard in the following categories, using the numbers:

- (1) unacceptable,
- (2) below average,
- (3) average,
- (4) above average,
- (5) exceptional,
- (6) not applicable

- timeliness.....
- quality of writing.....
- technical contents.....
- logic of arrangement of contents
- tables, charts, graphs, figures.....
- other

Q8 I read/use the: (tick one)

- French text only
- English text only
- both English and French texts

Q9 Please share any comment on any aspect of the IEC that you would like us to know:

.....

.....

.....

.....

.....

.....

.....

.....

.....

.....

.....

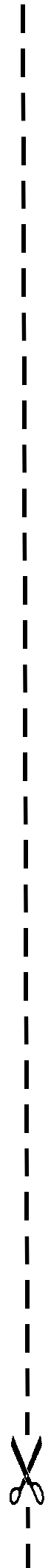

ISBN 2-8318-6386-4



9 782831 863863

ICS 97.040.20; 13.120

Typeset and printed by the IEC Central Office
GENEVA, SWITZERLAND