



Step-Up DC/DC Converter

■ Features

- A Guaranteed Start-Up from less than 0.9 V.
- High Efficiency.
- Low Quiescent Current.
- Less Number of External Components needed.
- Low Ripple and Low Noise.
- Space Saving **Pb-Free** Packages: SOT23-6

■ Applications

- Pagers.
- Cameras.
- Wireless Microphones.
- Pocket Organizers.
- Battery Backup Suppliers.
- Portable Instruments.

■ Pin Assignments

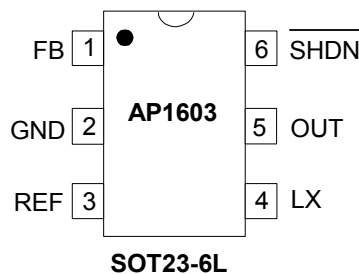

■ General Description

The AP1603 is a high efficiency step-up DC/DC converter for applications using 1 to 2 NiMH battery cells. Only three external components are required to deliver a fixed output voltage of 3.3V. The AP1603 starts up from less than 0.9V input with 1mA load. Pulse Frequency Modulation scheme brings optimized performance for applications with light output loading and low input voltages. The output ripple and noise are lower compared with the circuits operating in PSM mode.

The PFM control circuit operating in 150KHz (max.) switching rate results in smaller passive components. The space saving SOT23-6 packages make the AP1603 an ideal choice of DC/DC converter for space conscious applications, like pagers, electronic cameras, and wireless microphones.

■ Pin Descriptions

Name	Description
REF	1.2V Reference Voltage. Bypass with a 0.1 μ F capacitor.
OUT	Power Output. OUT provides bootstrap power to the IC.
LX	N-Channel and P-Channel Power MOSFET Drain
GND	Ground
SHDN	Shutdown Input. Drive high (>80% of V_{OUT}) for operating mode. Drive low (<20% of V_{OUT}) for shutdown mode. Connect to OUT for normal operation.
FB	Feedback

■ Ordering Information

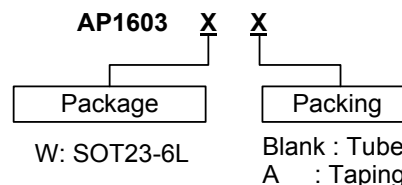

Step-Up DC/DC Converter

■ Block Diagram

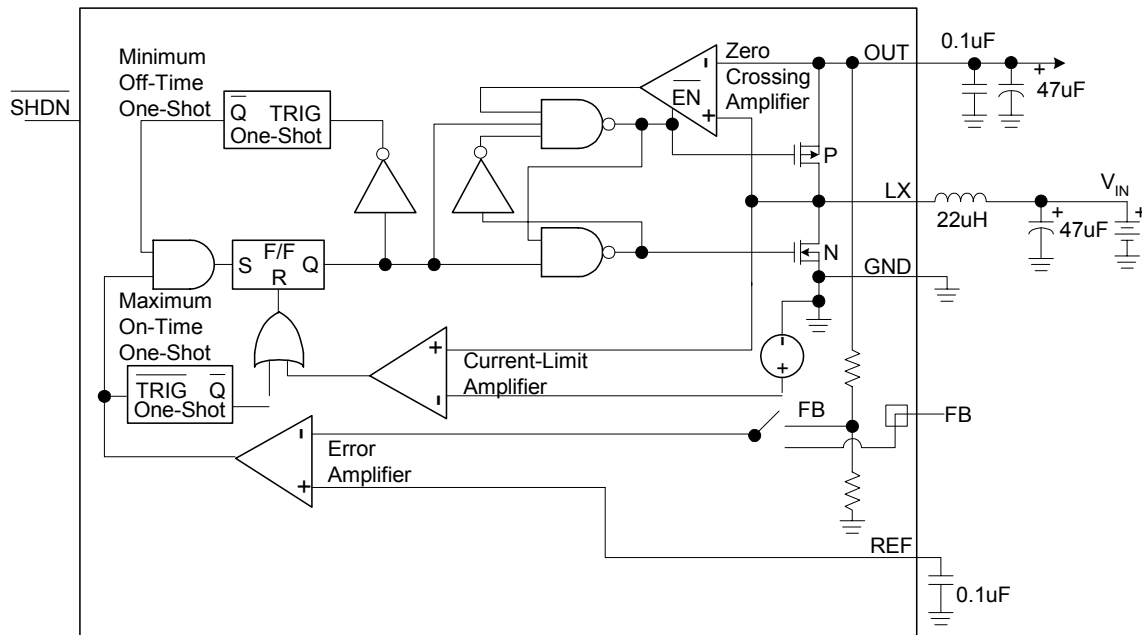

■ Absolute Maximum Ratings

Symbol	Parameter	Rating	Unit
V_{CC}	Supply Voltage (OUT to GND)	-0.3 to 5.5	V
V_{REF}	REF to GND	-0.3 to $V_{OUT}+0.3$	V
V_{SW}	Switch Voltage (LX to GND)	-0.3 to $V_{OUT}+0.3$	V
I_{OUT}	Output Current (OUT)	-0.8 to 0.2	A
I_{SW}	Switch Current (LX)	-0.8 to 0.2	A
T_{ST}	Storage Temperature Range	-65 to +150	°C
T_{OT}	Operation Temperature Range	-40 to +80	°C



■ Electrical Characteristics

($V_{IN}=2V$, $FB=V_{OUT}$, $R_L = \infty$, $T_A = 0^{\circ}C$ to $+85^{\circ}C$, unless otherwise noted. Typical values are at $T_A = +25^{\circ}C$.)

Symbol	Parameter	Conditions	Min.	Typ.	Max.	Unit
	Minimum Input Voltage		-	0.9	-	V
V_{IN}	Operating Voltage	$T_A = +25^{\circ}C$	1.1	-	5.5	V
	Start-Up Voltage	$T_A = +25^{\circ}C$, $R_L = 3k\Omega$ (Note 1)	-	0.9	1.1	V
	Start-Up Voltage Tempco		-	-4	-	mV/ $^{\circ}C$
	Output Voltage Range		2	-	5.5	V
I_{OUT}	Steady-State Output Current (Note2)	$FB=V_{OUT}=3.3V$	100	150	-	mA
		$V_{IN}=2.4V$, $FB=GND$, $V_{OUT}=5V$	-	80	-	
V_{REF}	Reference Voltage	$I_{REF}=0$	1.196	1.22	1.244	V
V_{OUT}	Output Voltage	$FB=V_{OUT}$	3.17	3.3	3.43	V
		$FB=GND$	4.8	5	5.2	
TEMPCO	Reference Voltage Tempco		-	0.05	-	mV/ $^{\circ}C$
V_{REF_LOAD}	Reference Voltage Load Regulation	$I_{REF}=0$ to 20 μA	-	15	80	mV
V_{REF_LINE}	Reference Voltage Line Regulation	$V_{IN}=1.1V$ to 3.6V	-	0.08	1.5	mV/V
$R_{DS(ON)}$	Internal NFET, PFET On-Resistance	$I_{LX}=100mA$	-	0.6	1.0	Ω
I_{LIM}	LX Switch Current Limit (NFET)		0.3	0.35	0.4	A
I_{LEAK}	LX Leakage Current	$V_{LX}=0, 5.5V$; $V_{OUT}=5.5V$	-	0.05	1	μA
	Operating Current into OUT	$V_{OUT}=3.3V$	-	16	35	μA
	Shutdown Current into OUT	$SHDN = GND$	-	0.1	1	μA
	Efficiency	$V_{OUT}=3.3V$, $I_{LOAD}=100mA$	-	90	-	%
t_{ON}	LX Switch On-Time		3	4	7	μs
t_{OFF}	LX Switch Off-Time		1.0	1.2	1.4	μs
I_{SHDN}	SHDN Input Current	$V_{SHDN}=0$ or V_{OUT}	-	0.07	50	nA
V_{IL}	SHDN Input Voltage	Based on V_{OUT} Voltage	-	-	0.2	V_{OUT}
V_{IH}			0.8	-	-	

Note 1: Start-up voltage operation is guaranteed with the addition of a Schottky 1N5819 external diode between the input and output.

Note 2: Steady-state output current indicates that the device maintains output voltage regulation under load.

Step-Up DC/DC Converter

■ Typical Application Circuit

(1) $V_{OUT}=5V$

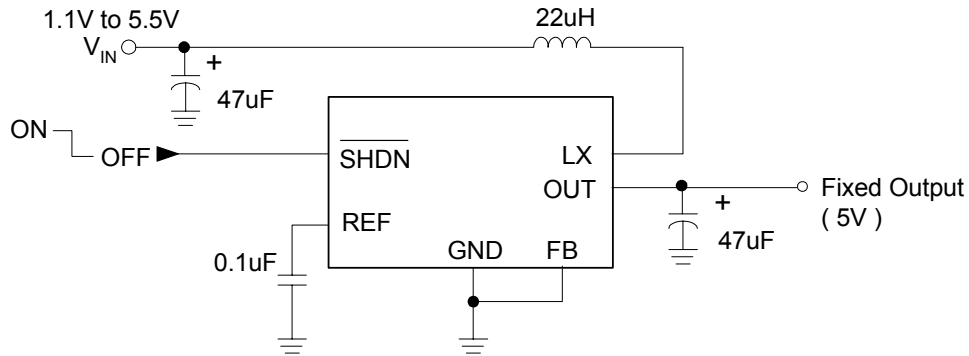

(2) $V_{OUT}=3.3V$

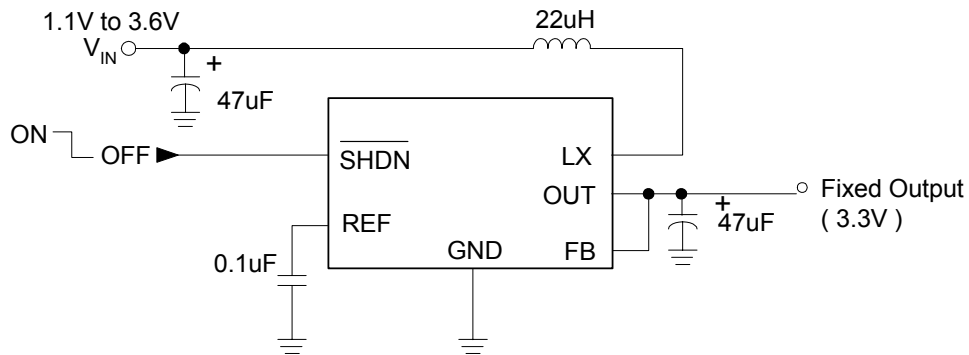

(3) $V_{OUT}=Adj$

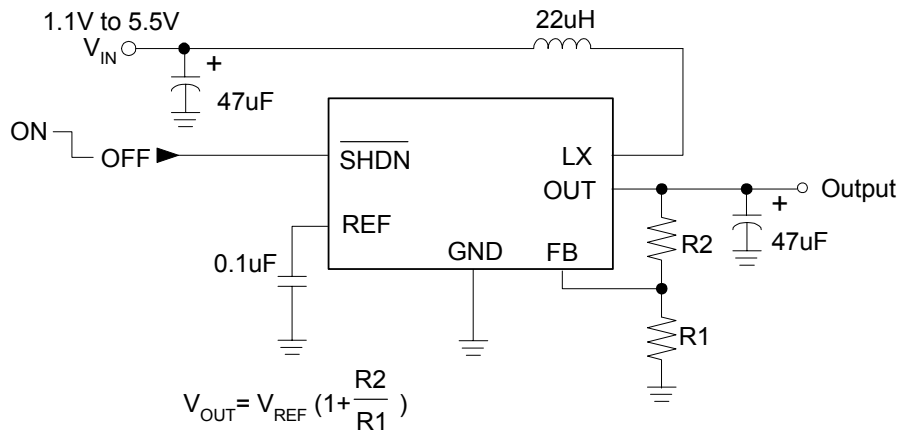

Step-Up DC/DC Converter

■ Typical Performance Characteristics

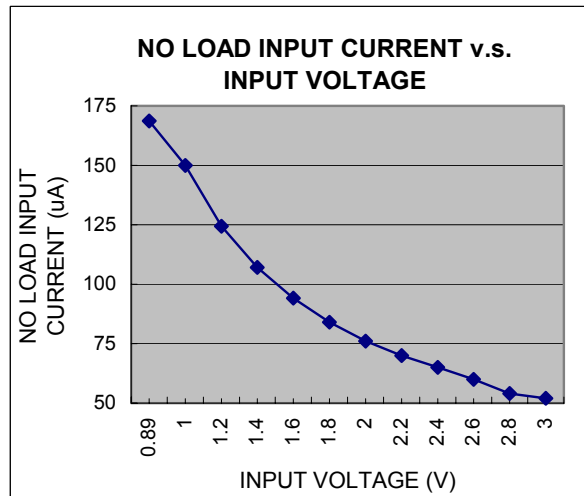
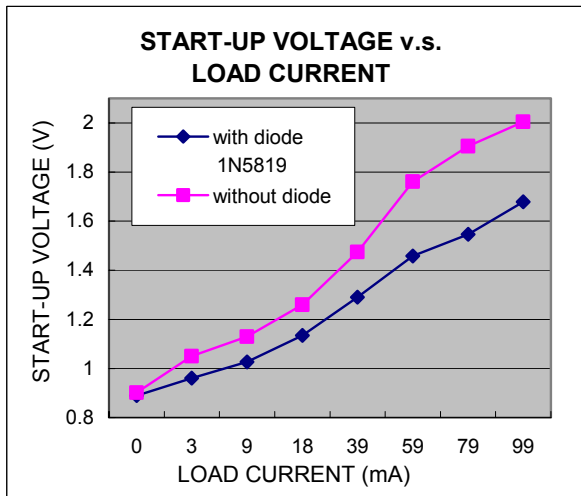
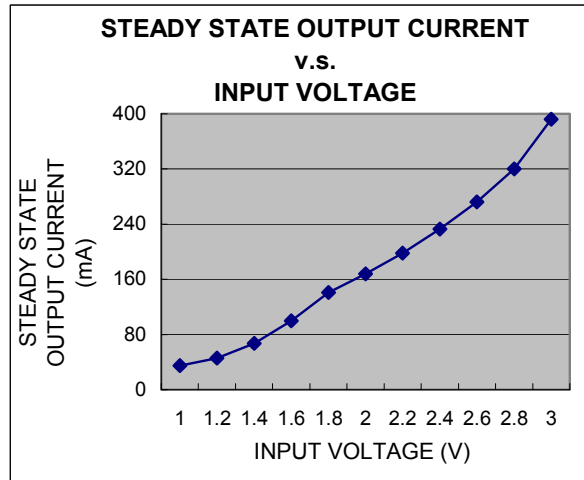
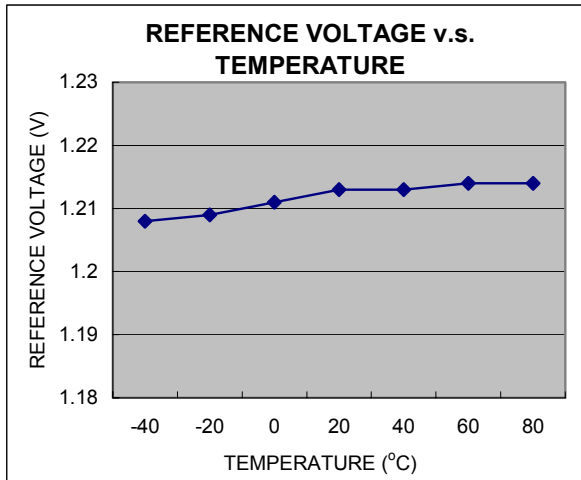

Step-Up DC/DC Converter

Typical Performance Characteristics (Continued)

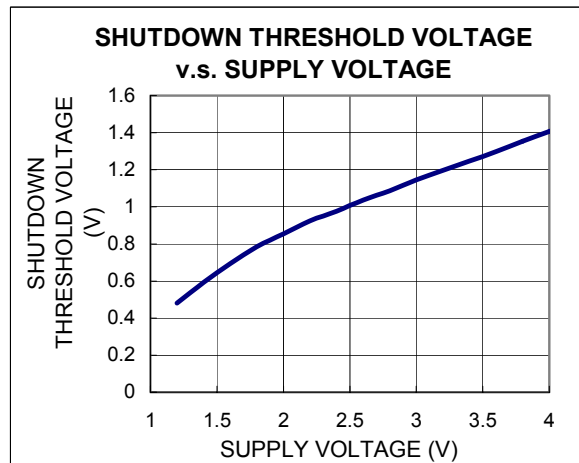
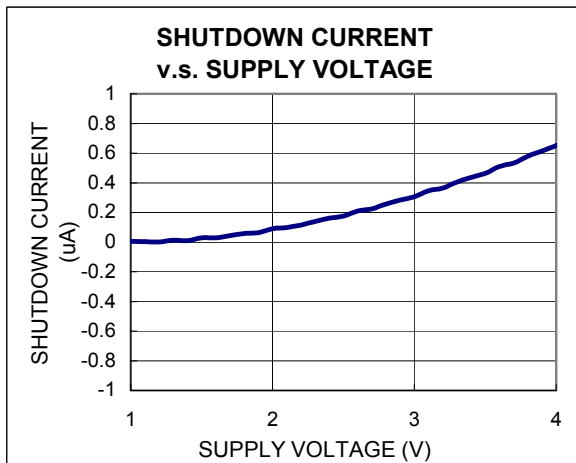
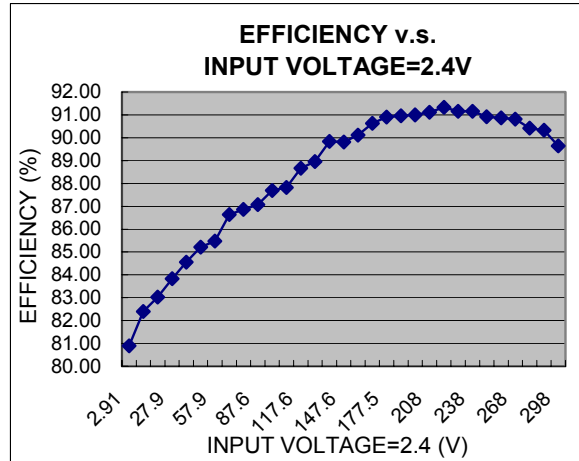
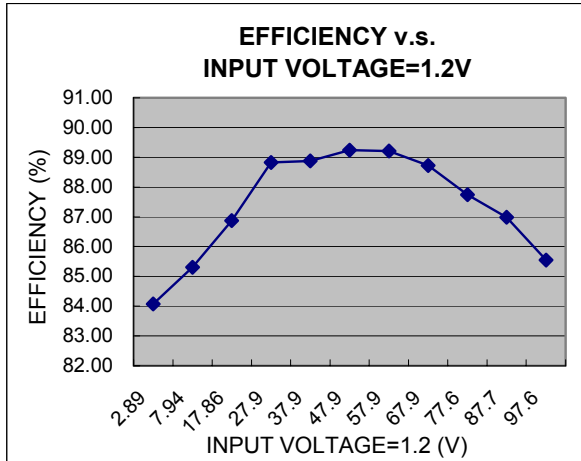

Marking Information

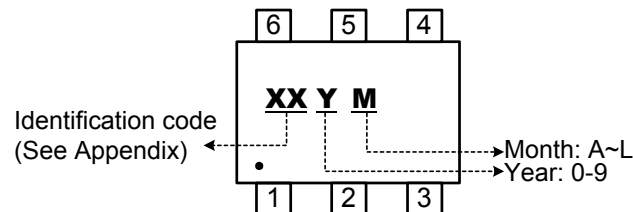

Appendix

Part Number	Package	Identification Code
AP1603	SOT23-6	EY



■ Function Descriptions

General Description

AP1603 PFM (pulse frequency modulation) converter IC series combine a switch mode converter, power MOSFET, and precision voltage reference in a single monolithic device. They offer both extreme low quiescent current, high efficiency, and very low gate threshold voltage to ensure start-up with low battery voltage (0.9V typ.). Designed to maximize battery life in portable products, and minimize switching losses by only switching as needed service the load. PFM converters transfer a discrete amount of energy per cycle and regulate the output voltage by modulating switching frequency with the constant turn-on time. Switching frequency depends on load, input voltage, and inductor value, and it can range up to 150KHz. The SW on resistance is typically 1 to 1.5 W to minimize switch losses. When the output voltage drops, the error comparator enables 150KHz oscillator that turns on the MOSFET around 7.5us and 2.5ms off time. Turning on the MOSFET allows inductor current to ramp up, storing energy in a magnetic field and when MOSFET turns off that force inductor current through diode to the output capacitor and load. As the stored energy is depleted, the current ramp down until the diode turns off. At this point, inductor may ring due to residual energy and stray capacitance. The output capacitor stores charge when current flowing through the diode is high, and release it when current is low, thereby maintaining a steady voltage across the load. As the load increases, the output capacitor discharges faster and the error comparator initiates cycles sooner, increasing the switching frequency. The maximum duty cycle ensure adequate time for energy transfer to output during the second half each cycle. Depending on circuit, PFM converter can operate in either discontinuous mode or continuous conduction mode. Continuous conduction mode means that the inductor current does not ramp to zero during each cycle.

Inductor Selection

To operate as an efficient energy transfer element, the inductor must fulfill three requirements. First, the inductance must be low enough for the inductor to store adequate energy under the worst case condition of minimum input voltage and switch ON time. Second, the inductance must also be high enough so maximum current rating of AP1603 and inductor are not exceed at the other worst case condition of maximum input voltage and ON time. Lastly, the inductor must have sufficiently low DC resistance so excessive power is not lost as heat in the windings. But unfortunately this is inversely related to physical size. Minimum and Maximum input voltage, output voltage and output current must be established before and inductor can be selected.

Capacitor Selection

A poor choice for a output capacitor can result in poor efficiency and high output ripple. Ordinary aluminum electrolyzers, while inexpensive may have unacceptably poor ESR and ESL. There are low ESR aluminum capacitors for switch mode DC-DC converters which work much better than general propose unit. Tantalum capacitors provide still better performance at more expensive. OS-CON capacitors have extremely low ESR in a small size. If capacitance is reduced, output ripple will increase. Most of the input supply is supplied by the input bypass capacitor. The capacitor voltage rating should be at least 1.25 times greater than a maximum input voltage.

■ Package Information

Package Type: SOT23-6L

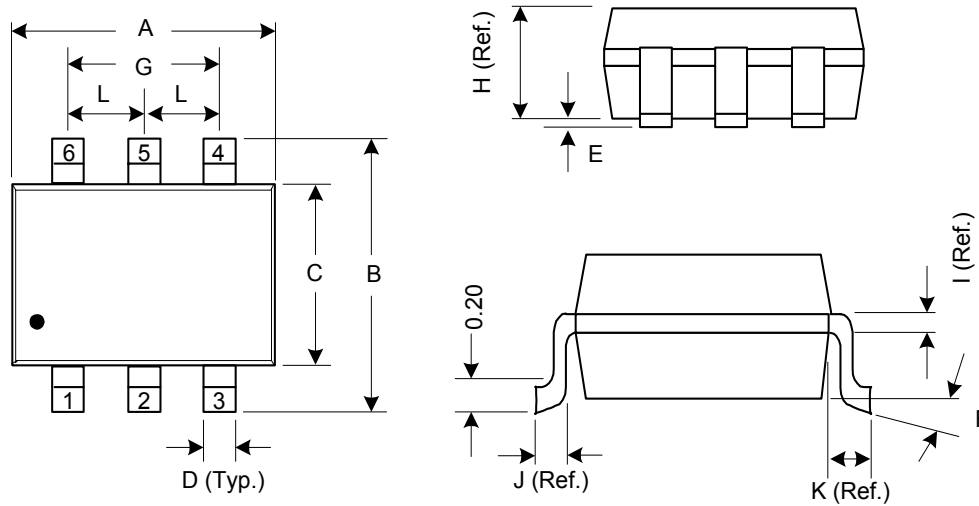

Symbol	Dimensions In Millimeters			Dimensions In Inches		
	Min.	Nom.	Max.	Min.	Nom.	Max.
A	2.70	2.90	3.10	0.106	0.114	0.122
B	2.60	2.80	3.00	0.102	0.110	0.118
C	1.40	1.60	1.80	0.055	0.063	0.071
D	0.30	0.43	0.55	0.012	0.017	0.022
E	0	0.05	0.10	0.000	0.002	0.004
F	0°	-	10°	0°	-	10°
G	1.90 Ref.			0.075 Ref.		
H	1.20 Ref.			0.047 Ref.		
I	0.12 Ref.			0.005 Ref.		
J	0.37 Ref.			0.015 Ref.		
K	0.60 Ref.			0.024 Ref.		
L	0.95 Ref.			0.037 Ref.		