

# Lamp controlgear —

## Part 1: General and safety requirements

The European Standard EN 61347-1:2001 has the status of a  
British Standard

ICS 29.140.01

## National foreword

This British Standard is the official English language version of EN 61347-1:2001. It is identical with IEC 61347-1:2000. Together with BS EN 61347-2-1:2001 it supersedes BS EN 60926:1996; with BS EN 61347-2-2:2001 it supersedes BS EN 61046:1995; with BS EN 61347-2-3:2001 it supersedes BS EN 60928:1995; with BS EN 61347-2-4, 2-5, 2-6 and 2-7:2001 it supersedes BS EN 60924:1991; with BS EN 61347-2-8:2001 it supersedes BS EN 60920:1991 and with BS EN 61347-2-9:2001 it supersedes BS EN 60922:1997. All these superseded parts will be withdrawn on 1 November 2003.

The UK participation in its preparation was entrusted by Technical Committee CPL/34, Lamps and related equipment, to Subcommittee CPL/34/3, Auxiliaries for Lamps, which has the responsibility to:

- aid enquirers to understand the text;
- present to the responsible international/European committee any enquiries on the interpretation, or proposals for change, and keep the UK interests informed;
- monitor related international and European developments and promulgate them in the UK.

A list of organizations represented on this subcommittee can be obtained on request to its secretary.

From 1 January 1997, all IEC publications have the number 60000 added to the old number. For instance, IEC 27-1 has been renumbered as IEC 60027-1. For a period of time during the change over from one numbering system to the other, publications may contain identifiers from both systems.

### Cross-references

Attention is drawn to the fact that CEN and CENELEC Standards normally include an annex which lists normative references to international publications with their corresponding European publications. The British Standards which implement these international or European publications may be found in the BSI Standards Catalogue under the section entitled "International Standards Correspondence Index", or by using the "Find" facility of the BSI Standards Electronic Catalogue.

A British Standard does not purport to include all the necessary provisions of a contract. Users of British Standards are responsible for their correct application.

**Compliance with a British Standard does not of itself confer immunity from legal obligations.**

### Summary of pages

This document comprises a front cover, an inside front cover, the EN title page, pages 2 to 59 and a back cover.

The BSI copyright date displayed in this document indicates when the document was last issued.

### Amendments issued since publication

Amd. No.	Date	Comments

This British Standard, having been prepared under the direction of the Electrotechnical Sector Committee, was published under the authority of the Standards Committee and comes into effect on 15 May 2001

© BSI 05-2001

ISBN 0 580 37386 X

EUROPEAN STANDARD

**EN 61347-1**

NORME EUROPÉENNE

EUROPÄISCHE NORM

January 2001

ICS 29.140.99

English version

**Lamp controlgear**  
**Part 1: General and safety requirements**  
**(IEC 61347-1:2000)**

Appareillages de lampes  
Partie 1: Prescriptions générales et  
prescriptions de sécurité  
(CEI 61347-1:2000)

Geräte für Lampen  
Teil 1: Allgemeine und  
Sicherheitsanforderungen  
(IEC 61347-1:2000)

This European Standard was approved by CENELEC on 2000-11-01. CENELEC members are bound to comply with the CEN/CENELEC Internal Regulations which stipulate the conditions for giving this European Standard the status of a national standard without any alteration.

Up-to-date lists and bibliographical references concerning such national standards may be obtained on application to the Central Secretariat or to any CENELEC member.

This European Standard exists in three official versions (English, French, German). A version in any other language made by translation under the responsibility of a CENELEC member into its own language and notified to the Central Secretariat has the same status as the official versions.

CENELEC members are the national electrotechnical committees of Austria, Belgium, Czech Republic, Denmark, Finland, France, Germany, Greece, Iceland, Ireland, Italy, Luxembourg, Netherlands, Norway, Portugal, Spain, Sweden, Switzerland and United Kingdom.

**CENELEC**

European Committee for Electrotechnical Standardization  
Comité Européen de Normalisation Electrotechnique  
Europäisches Komitee für Elektrotechnische Normung

**Central Secretariat: rue de Stassart 35, B - 1050 Brussels**

© 2001 CENELEC - All rights of exploitation in any form and by any means reserved worldwide for CENELEC members.

Ref. No. EN 61347-1:2001 E

## Foreword

The text of document 34C/508/FDIS, future edition 1 of IEC 61347-1, prepared by SC 34C, Auxiliaries for lamps, of IEC TC 34, Lamps and related equipment, was submitted to the IEC-CENELEC parallel vote and was approved by CENELEC as EN 61347-1 on 2000-11-01.

This EN 61347-1, together with the parts 2-1 to 2-9 of EN 61347, supersedes EN 60920, EN 60922, EN 60924, EN 60926, EN 60928 and EN 61046.

The following dates were fixed:

- latest date by which the EN has to be implemented at national level by publication of an identical national standard or by endorsement (dop) 2001-08-01
- latest date by which the national standards conflicting with the EN have to be withdrawn (dow) 2003-11-01

This part 1 of EN 61347 is to be used in conjunction with the appropriate part 2, which contains clauses to supplement or modify the corresponding clauses in part 1 to provide the relevant requirements for each type of product.

NOTE In this standard, the following print types are used:

- requirements: in roman type;
- *test specifications: in italic type;*
- notes: in smaller roman type.

Annexes designated "normative" are part of the body of the standard. In this standard, annexes A to H and ZA are normative. Annex ZA has been added by CENELEC.

---

## Endorsement notice

The text of the International Standard IEC 61347-1:2000 was approved by CENELEC as a European Standard without any modification.

---

**CONTENTS**

	Page
INTRODUCTION .....	5
<b>Clause</b>	
1 Scope .....	6
2 Normative references .....	6
3 Definitions .....	7
4 General requirements .....	11
5 General notes on tests .....	11
6 Classification .....	12
7 Marking .....	12
7.1 Items to be marked .....	12
7.2 Durability and legibility of marking .....	13
8 Terminals .....	13
9 Provisions for protective earthing .....	14
10 Protection against accidental contact with live parts .....	14
11 Moisture resistance and insulation .....	15
12 Electric strength .....	15
13 Thermal endurance test for windings of ballasts .....	16
14 Fault conditions .....	19
15 Construction .....	21
15.1 Wood, cotton, silk, paper and similar fibrous material .....	21
15.2 Printed circuits .....	21
16 Creepage distances and clearances .....	22
17 Screws, current-carrying parts and connections .....	24
18 Resistance to heat, fire and tracking .....	24
19 Resistance to corrosion .....	25
Annex A (normative) Test to establish whether a conductive part is a live part which may cause an electric shock .....	28
Annex B (normative) Particular requirements for thermally protected lamp controlgear .....	29
Annex C (normative) Particular requirements for electronic lamp controlgear with means of protection against overheating .....	36
Annex D (normative) Requirements for carrying out the heating tests of thermally protected lamp controlgear .....	39
Annex E (normative) Use of constant S other than 4 500 in $t_w$ tests .....	42
Annex F (normative) Draught-proof enclosure .....	45
Annex G (normative) Explanation of the derivation of the values of pulse voltages .....	46
Annex H (normative) Tests .....	51
Annex ZA (normative) Normative references to international publications with their corresponding European publications .....	58
Bibliography .....	57

	Page
Figure 1 – Relation between winding temperature and endurance test duration.....	26
Figure 2 – Creepage distances between conductors on printed boards not conductively connected to the supply mains .....	27
Figure D.1 – Exemple of heating enclosure for thermally protected ballasts .....	41
Figure E.1 – Assessment of claimed value of S.....	44
Figure G.1 – Circuit for measuring short-duration pulse energy.....	49
Figure G.2 – Suitable circuit for producing and applying long-duration pulses .....	50
Figure H.1 – Test arrangement for heating test .....	56
Table 1 – Electric strength test voltage .....	16
Table 2 – Theoretical test temperatures for ballasts subjected to an endurance test duration of 30 days .....	18
Table 3 – Minimum distances for a.c. (50/60 Hz) sinusoidal voltages .....	23
Table 4 – Minimum distances for non-sinusoidal pulse voltages .....	23
Table B.1 – Thermal protection operation.....	33
Table B.2 – Thermal protection operation.....	34

## INTRODUCTION

This first edition of IEC 61347-1, published in conjunction with parts 2-1 to 2-9, represents an editorial review IEC 60926, IEC 61046, IEC 60928, IEC 60924, IEC 60920 and IEC 60922. The formatting into separately published parts provides for ease of future amendments and revisions. Additional requirements will be added as and when a need for them is recognized.

The different parts which make up IEC 61347-2 are technically equivalent to the original IEC standards on which they are based. As such, products which have been shown to comply with IEC 60920, IEC 60922, IEC 60924, IEC 60926, IEC 60928 and IEC 61046 can be considered as complying with the requirements of the part 2 of IEC 61347 which replaces them. Similarly, where other standards call for compliance with IEC 60920, IEC 60922, IEC 60924, IEC 60926, IEC 60928 and IEC 61046, conformity with the equivalent part 2 of IEC 61347 is considered to meet this requirement.

This part of IEC 61347 provides a set of general and safety requirements and tests which are considered to be generally applicable to most types of lamp controlgear and which can be called up as required by the different parts that make up IEC 61347-2. This part 1 is thus not to be regarded as a specification in itself for any type of lamp controlgear, and its provisions apply only to particular types of lamp controlgear, to the extent determined by the appropriate part 2 of IEC 61347.

The parts which make up IEC 61347-2, in referring to any of the clauses of this part, specify the extent to which such a clause is applicable and the order in which the tests are to be performed; they also include additional requirements as necessary. The order in which the clauses of this part are numbered has no particular significance, as the order in which their provisions apply is determined for each type of lamp controlgear by the appropriate part 2 of IEC 61347-2 series. All such parts are self-contained and therefore do not contain references to each other.

Where the requirements of any of the clauses of this part of IEC 61347 are referred to in the various parts that make up IEC 61347-2 by the phrase "The requirements of clause n of IEC 61347-1 apply", this phrase will be interpreted as meaning that all requirements of the clause in question of part 1 apply, except any which are clearly inapplicable to the particular type of lamp controlgear covered by the part 2 concerned.

Lamp controlgear which complies with the text of this standard will not necessarily be judged to comply with the safety principles of the standard if, when examined and tested, it is found to have other features which impair the level of safety covered by these requirements.

Lamp controlgear employing materials or having forms of construction differing from those detailed in the requirements of this standard may be examined and tested according to the intent of the requirement and, if found to be substantially equivalent, may be judged to comply with the safety principles of the standard.

Performance requirements for lamp controlgear are the subject of IEC 60921, IEC 60923, IEC 60925, IEC 60927, IEC 60929 and IEC 61047 as appropriate for the type of lamp controlgear.

**NOTE** Safety requirements ensure that electrical equipment constructed in accordance with these requirements does not endanger the safety of persons, domestic animals or property when properly installed and maintained and used in applications for which it was intended.

Requirements for electronic lamp controlgear for other types of lamps will be the subject of a separate standard, as the need arises.

## LAMP CONTROLGEAR –

### Part 1: General and safety requirements

#### 1 Scope

This part of IEC 61347 specifies general and safety requirements for lamp controlgear for use on d.c. supplies up to 250 V and/or a.c. supplies up to 1 000 V at 50 Hz or 60 Hz.

This standard also covers lamp controlgear for lamps which are not yet standardized.

Tests dealt with in this standard are type tests. Requirements for testing individual lamp controlgear during production are not included.

Requirements for semi-luminaires are given in IEC 60598.

In addition to the requirements given in this standard, annex B sets out general and safety requirements applicable to thermally protected lamp controlgear.

Annex C sets out additional general and safety requirements as they apply to electronic lamp controlgear with means of protection against overheating.

#### 2 Normative references

The following normative documents contain provisions which, through reference in this text, constitute provisions of this part of IEC 61347. For dated references, subsequent amendments to, or revisions of, any of these publications do not apply. However, parties to agreements based on this part of IEC 61347 are encouraged to investigate the possibility of applying the most recent editions of the normative documents indicated below. For undated references, the latest edition of the normative document referred to applies. Members of IEC and ISO maintain registers of currently valid International Standards.

IEC 60065, *Audio, video and similar electronic apparatus – Safety requirements*

IEC 60081, *Double-capped fluorescent lamps – Performance specifications*

IEC 60112, *Method for determining the comparative and the proof tracking indices of solid insulating materials under moist conditions*

IEC 60249 (all parts), *Base materials for printed circuits*

IEC 60249-1, *Base materials for printed circuits – Part 1: Test methods*

IEC 60317-0-1, *Specifications for particular types of winding wires – Part 0: General requirements – Section 1: Enamelled round copper wire*

IEC 60417 (all parts), *Graphical symbols for use on equipment*

IEC 60529, *Degrees of protection provided by enclosures (IP Code)*

IEC 60598-1, *Luminaires – Part 1: General requirements and tests*

IEC 60691, *Thermal-links – Requirements and application guide*



IEC 60695-2-1/0, *Fire hazard testing – Part 2: Test methods – Section 1/sheet 0: Glow-wire test methods – General*

IEC 60695-2-2, *Fire hazard testing – Part 2: Test methods – Section 2: Needle-flame test*

IEC 60730-2-3, *Automatic electrical controls for household and similar use – Part 2: Particular requirements for thermal protectors for ballasts for tubular fluorescent lamps*

IEC 60901, *Single-capped fluorescent lamps – Performance specifications*

IEC 60921, *Ballasts for tubular fluorescent lamps – Performance requirements*

IEC 60923, *Auxiliaries for lamps – Ballasts for discharge lamps (excluding tubular fluorescent lamps) – Performance requirements*

IEC 60929, *AC supplied electronic ballasts for tubular fluorescent lamps – Performance requirements*

IEC 60990, *Methods of measurement of touch-current and protective conductor current*

IEC 61347-2-2, *Lamp controlgear – Part 2-2: Particular requirements for d.c. or a.c. supplied electronic step-down convertors for filament lamps*<sup>1)</sup>

IEC 61347-2-8, *Lamp controlgear – Part 2-8: Particular requirements for ballasts for fluorescent lamps*<sup>1)</sup>

IEC 61347-2-9, *Lamp controlgear – Part 2-9: Particular requirements for ballasts for discharge lamps (excluding fluorescent lamps)*<sup>1)</sup>

ISO 4046:1978, *Paper, board, pulp and related terms – Vocabulary*

### 3 Definitions

For the purpose of this part of IEC 61347, the following definitions apply.

#### 3.1

##### **lamp controlgear**

one or more components between the supply and one or more lamps which may serve to transform the supply voltage, limit the current of the lamp(s) to the required value, provide starting voltage and preheating current, prevent cold starting, correct power factor or reduce radio interference.

##### 3.1.1

##### **built-in lamp controlgear**

lamp controlgear generally designed to be built into a luminaire, a box, an enclosure or the like and not intended to be mounted outside a luminaire, etc. without special precautions. The controlgear compartment in the base of a road lighting column is considered to be an enclosure

---

<sup>1)</sup> To be published.

### 3.1.2

#### **independent lamp controlgear**

lamp controlgear consisting of one or more separate elements so designed that it can be mounted separately outside a luminaire, with protection according to the marking of the lamp controlgear and without any additional enclosure. This may consist of a built-in lamp controlgear housed in a suitable enclosure which provides all the necessary protection according to its markings

### 3.1.3

#### **integral lamp controlgear**

lamp controlgear which forms a non-replaceable part of a luminaire and which cannot be tested separately from the luminaire

## 3.2

### **ballast**

unit inserted between the supply and one or more discharge lamps which by means of inductance, capacitance, or a combination of inductance and capacitance, serves mainly to limit the current of the lamp(s) to the required value.

It may also include means for transforming the supply voltage and arrangements which help provide starting voltage and pre-heating current

### 3.2.1

#### **d.c. supplied electronic ballast**

d.c. to a.c. inverter using semiconductor devices which may include stabilizing elements for supplying power to one or more fluorescent lamps

### 3.2.2

#### **reference ballast**

special inductive ballast designed for the purpose of providing comparison standards for use in testing ballasts and for the selection of reference lamps. It is essentially characterized by a stable voltage-to-current ratio, which is relatively uninfluenced by variations in current, temperature and magnetic surroundings, as outlined in annex C of IEC 60921 and annex A of IEC 60923

## 3.3

### **reference lamp**

lamp selected for testing ballasts which, when associated with a reference ballast, has electrical characteristics which are close to the nominal values as stated in the relevant lamp standard

## 3.4

### **calibration current of a reference ballast**

value of the current on which are based the calibration and control of the reference ballast

NOTE Such a current should preferably be approximately equal to the nominal running current of the lamps for which the reference ballast is suitable.

## 3.5

### **supply voltage**

voltage applied to the complete circuit of lamp(s) and lamp controlgear

## 3.6

### **working voltage**

highest r.m.s. voltage which may occur across any insulation at rated supply voltage, transients being neglected, in open-circuit conditions or during normal operation

**3.7****design voltage**

voltage declared by the manufacturer to which all the lamp controlgear characteristics are related. This value is not less than 85 % of the maximum value of the rated voltage range

**3.8****voltage range**

range of supply voltage over which the ballast is intended to be operated

**3.9****supply current**

current supplied to the complete circuit of lamp(s) and lamp controlgear

**3.10****live part**

conductive part which may cause an electric shock in normal use. The neutral conductor is, however, regarded as a live part

NOTE The test to determine whether or not a conductive part is a live part which may cause an electric shock is given in annex A.

**3.11****type test**

test or series of tests made on a type-test sample for the purpose of checking compliance of the design of a given product with the requirements of the relevant standard

**3.12****type-test sample**

sample consisting of one or more similar units submitted by the manufacturer or responsible vendor for the purpose of a type test

**3.13****circuit power factor** $\lambda$ 

power factor of the combination of lamp controlgear and the lamp or lamps for which the lamp controlgear is designed

**3.14****high power factor ballast**

ballast having a circuit power factor of at least 0,85 (leading or lagging)

NOTE 1 The value 0,85 takes into account the distortion of the current waveform.

NOTE 2 For North America, a high power factor is defined as a power factor of at least 0,9.

**3.15****rated maximum temperature** $t_c$ 

highest permissible temperature which may occur on the outer surface (at the indicated place, if marked) under normal operating conditions and at the rated voltage or the maximum of the rated voltage range

**3.16****rated maximum operating temperature of a lamp controlgear winding** $t_w$ 

winding temperature assigned by the manufacturer as the highest temperature at which 50/60 Hz lamp controlgear may be expected to have a service life of at least 10 years' continuous operation

**3.17****rectifying effect**

effect which may occur at the end of lamp life when one cathode is either broken or has insufficient electron emission, resulting in the arc current being constantly unequal in consecutive half-cycles

**3.18****test duration of endurance test****D**

optional duration of the endurance test on which the temperature conditions are based

**3.19****degradation of insulation of a ballast winding****S**

constant which determines the degradation of ballast insulation

**3.20****ignitor**

device intended to generate voltage pulses to start discharge lamps and which does not provide for the preheating of electrodes

NOTE The element that releases the starting voltage pulse may be either triggered or non-triggered.

**3.21****protective earth (ground)**

(5019 of IEC 60417)

terminal to which are connected parts which are connected to earth for safety reasons

**3.22****functional earth (ground)**

(5017 of IEC 60417)

terminal to which are connected parts which may be necessary to connect to earth for reasons other than safety

NOTE 1 In some instances, starting aids adjacent to the lamp(s) are connected to one of the output terminals but need not be connected to the earth on the supply side.

NOTE 2 In some cases, functional earthing may be necessary to facilitate starting or for e.m.c. purposes.

**3.23****frame (chassis)**

(5020 of IEC 60417)

terminal whose potential is taken as reference

## 4 General requirements

Lamp controlgear shall be so designed and constructed that in normal use it operates without danger to the user or surroundings.

Compliance is checked by carrying out all the tests specified.

In addition, independent lamp controlgear shall comply with the requirements of IEC 60598-1, including the classification and marking requirements of that standard such as IP classification,  marking, etc.

## 5 General notes on tests

### 5.1 Tests according to this standard are type tests.

**NOTE** The requirements and tolerances permitted by this standard are related to testing of a type-test sample submitted by the manufacturer for that purpose. Compliance of the type-test sample does not ensure compliance of the whole production of a manufacturer with this safety standard.

Conformity of production is the responsibility of the manufacturer and may include routine tests and quality assurance in addition to type testing.

**5.2** Unless otherwise specified, the tests are carried out at an ambient temperature of 10 °C to 30 °C.

**5.3** Unless otherwise specified, the type test is carried out on one sample consisting of one or more items submitted for the purpose of the type test.

In general, all tests are carried out on each type of lamp controlgear or, where a range of similar lamp controlgear is involved, for each wattage in the range or on a representative selection from the range, as agreed with the manufacturer.

Certain countries require that three samples of lamp controlgear be tested and, in such cases, if more than one sample fails, then the type is rejected. If one sample fails, the test is repeated using three other samples and all of these shall comply with the test requirements.

**5.4** The tests shall be carried out in the order listed in this standard unless otherwise specified in parts 2 of IEC 61347.

**5.5** For the thermal test, independent lamp controlgear shall be mounted in a test corner consisting of three dull-black painted wooden/wood fibre boards 15 mm to 20 mm thick and arranged so as to resemble two walls and the ceiling of a room. The lamp controlgear is secured to the ceiling as close as possible to the walls, the ceiling extending at least 250 mm beyond the other side of the lamp controlgear.

**5.6** For d.c. supplied ballasts intended for use from a battery supply it is permissible to substitute a d.c. power source other than a battery, provided that the source impedance is equivalent to that of a battery.

**NOTE** A non-inductive capacitor of appropriate rated voltage and with a capacitance of at least 50 µF, connected across the supply terminals of the unit under test normally provides a source impedance simulating that of a battery.

## 6 Classification

Lamp controlgear is classified, according to the method of installation, as

- built-in;
- independent;
- integral.

## 7 Marking

### 7.1 Items to be marked

The parts that make up IEC 61347-2 state which of the following items shall be marked as mandatory markings or provided as information to be given either on the lamp controlgear or made available in the manufacturer's catalogue or similar.

- a) Mark of origin (trade mark, manufacturer's name or name of the responsible vendor/supplier).
- b) Model number or type reference of the manufacturer.

- c) Symbol for independent lamp controlgear  if applicable.

- d) The correlation between replaceable and interchangeable parts, including fuses, of lamp controlgear shall be marked unambiguously by legends on the lamp controlgear or, with the exception of fuses, be specified in the manufacturer's catalogue.
- e) Rated supply voltage (or voltages, if there are several), voltage range, supply frequency and supply current(s); the supply current may be given in the manufacturer's literature.

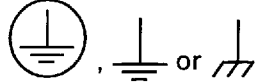
- f) The earthing terminals (if any) shall be identified by the symbol,  These symbols shall not be placed on screws or other easily removable parts.
- g) The claimed value of the rated maximum operating temperature of the winding following the symbol  $t_w$ , values increasing in multiples of 5 °C.

- h) Indication that the lamp controlgear does not rely upon the luminaire enclosure for protection against accidental contact with live parts.

- i) Indication of the cross-section of conductors for which the terminals, if any, are suitable.

Symbol: relevant value(s) in square millimetres (mm<sup>2</sup>) followed by a small square.

- j) The lamp type and rated wattage or wattage range for which the lamp controlgear is suitable, or the designation as indicated on the lamp data sheet of the type(s) of lamp(s) for which the lamp controlgear is designed. If the lamp controlgear is intended to be used with more than one lamp, the number and rated wattages of each lamp shall be indicated.

NOTE 1 For lamp controlgear specified in IEC 61347-2-2, it is assumed that a marked wattage range includes all ratings within the range unless otherwise indicated in the manufacturer's literature.

k) Wiring diagram indicating the position and purpose of terminals. In the case of lamp controlgear having no terminals, a clear indication shall be given on the wiring diagram of the significance of the code used for connecting wires. Lamp controlgear that operates in specific circuits only shall be identified accordingly, for example by marking or wiring diagram.

l) Value of  $t_c$ .

If this relates to a certain place on the lamp controlgear, this place shall be indicated or specified in the manufacturer's catalogue.

m) Symbol for temperature declared, thermally protected controlgear  (see annex B). The dots in the triangle shall be replaced by the value of the rated maximum case temperature in degrees Celsius assigned by the manufacturer, values increasing in multiples of 10.

n) Heat sink(s) required additional to the lamp controlgear.

o) The limiting temperature of the winding under abnormal conditions which shall be respected when the controlgear is built into a luminaire, as information for luminaire design.

NOTE 2 In the case of lamp controlgear intended for circuits which do not produce abnormal conditions, or are for use only with starting devices which exempt the lamp controlgear from the abnormal conditions of annex C of IEC 60598-1, the winding temperature under abnormal conditions is not indicated.

p) The test period for the endurance test for lamp controlgear which, at the manufacturer's choice, shall be tested for a period longer than 30 days, may be indicated with the symbol D, followed by the appropriate number of days, 60, 90 or 120 in 10-day periods, the whole being placed between the brackets immediately after the  $t_w$  indication. For example, (D6) for controlgear to be tested for a period of 60 days.

NOTE 3 The standard endurance test period of 30 days need not be indicated.

q) For lamp controlgear for which a constant S other than 4 500 is claimed by the manufacturer, the symbol S together with its appropriate value in thousands, for example "S6", if S has a value of 6 000.

NOTE 4 Preferred values of S are: 4 500, 5 000, 6 000, 8 000, 11 000, 16 000.

## 7.2 Durability and legibility of marking

Marking shall be durable and legible.

*Compliance is checked by inspection and by trying to remove the marking by rubbing lightly, for 15 s each time, with two pieces of cloth, one soaked with water and the other with petroleum spirit.*

*The marking shall be legible after the test.*

NOTE The petroleum spirit used should consist of a solvent hexane with a content of aromatics of maximum 0,1 % volume percentage, a kauri-butanol value of 29, an initial boiling-point of approximately 65 °C, a dry-point of approximately 69 °C and a density of approximately 0,68 g/cm<sup>3</sup>.

## 8 Terminals

Screw terminals shall comply with section 14 of IEC 60598-1.

Screwless terminals shall comply with section 15 of IEC 60598-1.

## 9 Provisions for protective earthing

Earthing terminals shall comply with the requirements of clause 8. The electrical connection/clamping means shall be adequately locked against loosening, and it shall not be possible to loosen the electrical connection/clamping means by hand without the use of a tool. For screwless terminals, it shall not be possible to loosen the clamping means/electrical connection unintentionally.

Earthing of lamp controlgear (other than independent lamp controlgear) via means of fixing the lamp controlgear to earthed metal is permitted. However, if a lamp controlgear has an earthing terminal, this terminal shall only be used for earthing the lamp controlgear.

All parts of an earthing terminal shall be such as to minimize the danger of electrolytic corrosion resulting from contact with the earth conductor or any other metal in contact with them.

The screw and the other parts of the earthing terminal shall be made of brass or other metal no less resistant to corrosion, or material with a non-rusting surface and at least one of the contact surfaces shall be bare metal.

Compliance is checked by inspection, by manual test and according to the requirements of clause 8.

Lamp controlgear with conductors for protective earthing provided by tracks on printed circuit boards shall be tested as follows.

*A current from an a.c. source of 25 A is passed for 1 min between the earthing terminal or earthing contact via the track on the printed board and each of the accessible metal parts in turn.*

*After the test, the requirements of 7.2.1 of IEC 60598-1 shall apply.*

## 10 Protection against accidental contact with live parts

**10.1** Lamp controlgear which do not rely upon the luminaire enclosure for protection against electric shock shall be sufficiently protected against accidental contact with live parts (see annex A) when installed as in normal use.

Integral lamp controlgear, which relies upon the luminaire enclosure for protection, shall be tested according to its intended use.

Lacquer or enamel is not considered to be adequate protection or insulation for the purpose of this requirement.

Parts providing protection against accidental contact shall have adequate mechanical strength and shall not work loose in normal use. It shall not be possible to remove them without the use of a tool.

*Compliance is checked by inspection and by a manual test, and with regard to protection against accidental contact, by means of the test finger as shown in figure 1 of IEC 60529 using an electrical indicator to show contact. This finger is applied in all possible positions, if necessary, with a force of 10 N.*



It is recommended that a lamp be used for the indication of contact and that the voltage be not less than 40 V.

**10.2** Lamp controlgear incorporating capacitors of total capacitance exceeding 0,5  $\mu\text{F}$  shall be constructed so that the voltage at the lamp controlgear terminations does not exceed 50 V, 1 min after disconnection of the lamp controlgear from a source of supply at rated voltage.

## 11 Moisture resistance and insulation

Lamp controlgear shall be moisture-resistant. They shall not show any appreciable damage after being subjected to the following test.

The lamp controlgear is placed in the most unfavourable position of normal use, in a humidity cabinet containing air with a relative humidity maintained between 91 % and 95 %. The temperature of the air at all places where samples can be located shall be maintained within 1 °C of any convenient value  $t$  between 20 °C and 30 °C.

*Before being placed in the humidity cabinet, the sample is brought to a temperature between  $t$  and  $(t + 4)$  °C. The sample shall be kept in the cabinet for 48 h.*

NOTE In most cases, the sample may be brought to the specified temperature between  $t$  and  $(t + 4)$  °C by keeping it in a room at this temperature for at least 4 h before the humidity treatment.

In order to achieve the specified conditions within this cabinet, it is necessary to ensure constant circulation of the air within, and, in general, to use a cabinet which is thermally insulated.

*Before the insulation test, visible drops of water, if any, are removed by means of blotting paper.*

*Immediately after the moisture treatment, the insulation resistance shall be measured with a d.c. voltage of approximately 500 V, 1 min after application of the voltage. Lamp controlgear having an insulating cover or envelope shall be wrapped with metal foil.*

Insulation resistance shall be not less than 2 M $\Omega$  for basic insulation.

Insulation shall be adequate

- a) between live parts of different polarity which are or can be separated;
- b) between live parts and external parts, including fixing screws;
- c) between live parts and control terminals, where relevant.

In the case of lamp controlgear having an internal connection or component between one or more output terminals and the earth terminal, such a connection shall be removed during this test.

## 12 Electric strength

Lamp controlgear shall have adequate electric strength.

Immediately after the measurement of the insulation resistance, the lamp controlgear shall withstand an electric strength test for 1 min applied between the parts specified in clause 11.

The test voltage of substantially sine-wave form, having a frequency of 50 Hz or 60 Hz shall correspond to the values in table 1. Initially, not more than half the specified voltage shall be applied, the voltage then being raised rapidly to the prescribed value.

**Table 1 – Electric strength test voltage**

Working voltage $U$	Test voltage V
Up to and including 42 V	500
Above 42 V up to and including 1 000 V	$2 U + 1\ 000$
NOTE For converters, the electric strength test between parts separated by reinforced insulation shall be in accordance with figure 9, curve B, of IEC 60065.	

No flashover or breakdown shall occur during the test.

The high-voltage transformer used for the test shall be so designed that when the output terminals are short-circuited after the output voltage has been adjusted to the appropriate test voltage, the output current is at least 200 mA.

The overcurrent relay shall not trip when the output current is less than 100 mA.

The r.m.s. value of the test voltage applied shall be measured to within  $\pm 3\%$ .

The metal foil referred to in clause 11 shall be placed so that no flashover occurs at the edges of the insulation.

Glow discharges without drop in voltage are neglected.

### 13 Thermal endurance test for windings of ballasts

Windings of ballasts shall have adequate thermal endurance.

*Compliance is checked by the following test.*

*The purpose of this test is to check the validity of the rated maximum operating temperature ( $t_w$ ) marked on the ballast. The test is carried out on seven new ballasts which have not been subjected to the preceding tests. They shall not be used for further testing.*

*This test may also be applied to ballasts which form an integral part of a luminaire and which cannot be tested separately, thereby enabling such integral ballasts to be made with a  $t_w$  value.*

*Before the test, each ballast shall start and operate a lamp normally, and the lamp arc current shall be measured under normal conditions of operation and at a rated voltage. Details of the thermal endurance test are prescribed below. The thermal conditions shall be so adjusted that the objective duration of the test is as indicated by the manufacturer. If no indication is given, the test period shall be 30 days.*

*The test is carried out in an appropriate oven.*

The ballast shall function electrically in a manner similar to that in normal use, and, in the case of capacitors, components or other auxiliaries not subjected to the test, these shall be disconnected and reconnected again in the circuit but outside the oven. Other components which do not influence the operating conditions of the windings may be removed.

NOTE 1 Where it is necessary to disconnect capacitors, components or other auxiliaries, it is recommended that the manufacturer supplies special ballasts with these parts removed and any necessary additional connections brought out from the ballast.

*In general, to obtain normal operating conditions, the ballast is tested with the appropriate lamp.*

*The ballast container, if of metal, is earthed. Lamps are always kept outside the oven.*

*For certain inductive ballasts of simple impedance (for example, switch-start choke ballasts), the test is made without a lamp or resistor, provided the current is adjusted to the same value as found with the lamp at rated supply voltage.*

*The ballast is connected to the power supply so that the voltage stress between the lamp controlgear winding and earth is similar to the one in the lamp method.*

*Seven ballasts are placed in the oven, and the rated supply voltage applied to each of the circuits.*

*The oven thermostats are then regulated so that the internal temperature of the oven attains a value such that the temperature of the hottest winding in each of the ballasts is approximately equal to the theoretical value given in table 2.*

For ballasts subject to a test duration longer than 30 days, the theoretical test temperatures shall be calculated by means of equation (2) as explained in note 3 of this clause.

*After 4 h, the actual temperature of the winding is determined by the "change-in-resistance" method, and, if necessary, the oven thermostats are readjusted to approximate as closely as possible the desired test temperature. Thereafter, a daily reading of the air temperature in the oven is taken to ensure that the thermostats are maintained at the correct value to within  $\pm 2$  °C.*

*The winding temperatures are measured again after 24 h and the final test period for each lamp controlgear is determined from equation (2). Figure 1 illustrates this in graphical form. The permissible difference between the actual temperature of the hottest winding of any of the ballasts under test and the theoretical value shall be such that the final test period is at least equal to, but not more than twice, the foreseen test period.*

**Table 2 – Theoretical test temperatures for ballasts subjected to an endurance test duration of 30 days**

Constant S	Theoretical test temperature					
	°C					
	S4,5	S5	S6	S8	S11	S16
For $t_w =$ 90	163	155	142	128	117	108
95	171	162	149	134	123	113
100	178	169	156	140	128	119
105	185	176	162	146	134	125
110	193	183	169	152	140	130
115	200	190	175	159	146	136
120	207	197	182	165	152	141
125	215	204	189	171	157	147
130	222	211	196	177	163	152
135	230	219	202	184	169	158
140	238	226	209	190	175	163
145	245	233	216	196	181	169
150	253	241	223	202	187	175

NOTE Unless otherwise indicated on the ballast, the theoretical test temperatures specified in column S4,5 apply. The use of a constant other than S4,5 must be justified in accordance with annex E.

NOTE 2 For the measurement of winding temperature by the "change-in-resistance" method, the following equation (1) is applicable:

$$t_2 = \frac{R_2}{R_1} (234,5 + t_1) - 234,5 \tag{1}$$

where

$t_1$  is the initial temperature in degrees Celsius;

$t_2$  is the final temperature in degrees Celsius;

$R_1$  is the resistance at temperature  $t_1$ ;

$R_2$  is the resistance at temperature  $t_2$ .

The constant 234,5 relates to copper windings; for aluminium, this constant should be 229.

*No attempt shall be made to hold the winding temperature constant after the measurement taken after 24 h. Only the ambient air temperature shall be stabilized by the thermostatic control.*

*The test period for each ballast starts from the time the ballast is connected to the supply. At the end of its test, the relevant ballast is disconnected from the supply but is not removed from the oven until the tests on the other ballast have been completed.*

NOTE 3 The theoretical test temperatures given in figure 1 correspond to a working life of 10 years' continuous operation at the rated maximum operating temperature  $t_w$ .

They are computed using the following equation:

$$\log L = \log L_o + S \left( \frac{1}{T} - \frac{1}{T_w} \right) \quad (2)$$

where

$L$  is the objective endurance test life in days (30, 60, 90 or 120);

$L_o = 3\,652$  days (10 years);

$T$  is the theoretical test temperature in kelvins ( $t + 273$ );

$T_w$  is the rated maximum operating temperature in kelvins ( $t_w + 273$ );

$S$  is the constant depending on the design of the lamp controlgear and the winding insulation used.

After the test, when the ballasts have returned to room temperature, they shall satisfy the following requirements.

- a) At rated voltage, the ballast shall start the same lamp and the lamp arc current shall not exceed 115 % of the value measured before the test, as described above.

NOTE 4 This test is to determine any adverse change in the ballast setting.

- b) The insulation resistance between the winding and the ballast case, measured at approximately 500 V d.c. shall be not less than 1 M $\Omega$ .

The result of the test is considered to be satisfactory if at least six of the seven ballasts satisfy these requirements. The test is considered to have failed if more than two ballasts fail the test.

In the case of two failures, the test is repeated with seven more ballasts and no failure of these is permitted.

## 14 Fault conditions

Lamp controlgear shall be so designed that, when operated under fault conditions, there shall be no emission of flames or molten material or production of flammable gases. The protection against accidental contact in accordance with 10.1 shall not be impaired.

Operation under fault conditions denotes that each of the conditions specified in 14.1 to 14.4 is applied in turn and, associated with it, those other fault conditions which are a logical consequence thereof, with the provision that only one component at a time should be subjected to a fault condition.

Examination of the apparatus and its circuit diagram will generally show the fault conditions which should be applied. These are applied in sequence in the order which is most convenient.

Totally enclosed lamp controlgear or components shall not be opened for examination nor for the application of internal fault conditions. However, in case of doubt, in conjunction with the examination of the circuit diagram, either the output terminals shall be short-circuited or, in agreement with the manufacturer, a specially prepared lamp controlgear shall be submitted for testing.

A lamp controlgear or component is considered to be totally enclosed if it is encapsulated in a self-hardening compound bonded to the relevant surfaces so that clearances in air do not exist.

Components in which, according to the manufacturer's specifications, a short circuit cannot occur, or which eliminate a short circuit, shall not be bridged. Components in which, according to the manufacturer's specification, an open circuit cannot occur shall not be interrupted.

The manufacturer shall show evidence that the components behave in the foreseen way, for example by showing compliance with the relevant specification.

Capacitors, resistors or inductors not complying with a relevant standard shall be short-circuited or disconnected, whichever is the more unfavourable.

For lamp controlgear marked with , the lamp controlgear case temperature at any place shall not exceed the marked value.

NOTE Lamp controlgear and filter coils without these symbols are checked together with the luminaire in accordance with IEC 60598-1.

**14.1** Short circuit across creepage distances and clearances, if less than the values specified in clause 16, taking into account any reduction allowed in 14.1 to 14.4

NOTE 1 Creepage distances and clearances below the values of clause 16 are not allowed between live parts and accessible metal parts.

Between conductors protected from surge energy from the supply (for example, by choke winding or capacitor) which are on a printed board complying with the pull-off and peel strength requirements specified in IEC 60249, the creepage distance requirements are modified. The distances of table 3 are replaced by the values calculated from the following equation:

$$\log d = 0,78 \log \frac{\hat{V}}{300} \quad (3)$$

with a minimum of 0,5 mm

where

$d$  is the distance, in millimetres;

$\hat{V}$  is the peak value of the voltage in volts.

These distances can be determined by reference to figure 2.

NOTE 2 Coverings of lacquer or the like on printed circuit boards are ignored when calculating the distances.

Creepage distances of printed circuit boards may have lower values than described above if coating according to IEC 60664-3 is used. This applies also for creepage distances between live parts and parts which are connected to accessible metal parts. Tests according to the relevant clauses of IEC 60664-3 shall show compliance with the requirement.

**14.2** Short circuit across or, if applicable, interruption of semi-conductor devices

Only one component at a time shall be short-circuited (or interrupted).

### 14.3 Short circuit across insulation consisting of covering of lacquer, enamel or textile

Such coverings are ignored in assessing the creepage distances and clearances specified in table 3. However, if enamel forms the insulation of a wire and withstands the voltage test prescribed in clause 13 of IEC 60317-0-1, it is considered as contributing 1 mm to those creepage distances and clearances in air.

This subclause does not imply a need to short-circuit the insulation between turns of coils, insulating sleeves or tubing.

### 14.4 Short circuit across electrolytic capacitors

Compliance is checked by operating the lamp controlgear at any voltage between 0,9 and 1,1 times the rated supply voltage with the lamp connected and with the lamp controlgear case at  $t_c$ ; then, each of the fault conditions outlined in 14.1 to 14.4 inclusive shall be applied in turn.

The test is continued until stable conditions are obtained, and the lamp controlgear case temperature is measured. When making the tests of 14.1 to 14.4, components such as resistors, capacitors, semiconductors, fuses, etc. may fail. It is permitted to replace such components so as to continue the test.

After the tests, when the lamp controlgear has returned to ambient temperature, the insulation resistance measured at approximately 500 V d.c. shall be not less than 1 M $\Omega$ .

To check whether gases liberated from component parts are flammable or not, a test with a high-frequency spark generator is made.

To check whether accessible parts have become live, the test according to annex A is carried out.

To check whether emission of flames or molten material might present a safety hazard, the test specimen is wrapped with a tissue paper, as specified in 6.86 of ISO 4046, and shall not ignite.

## 15 Construction

### 15.1 Wood, cotton, silk, paper and similar fibrous material

Wood, cotton, silk, paper and similar fibrous material shall not be used as insulation, unless impregnated.

*Compliance is checked by inspection.*

### 15.2 Printed circuits

Printed circuits are permitted for internal connections.

*Compliance is checked by reference to clause 14 of this standard.*

## **16 Creepage distances and clearances**

Creepage distances and clearances shall be not less than the values given in tables 3 and 4, as appropriate, unless otherwise specified in clause 14.

The contribution to the creepage distance of any groove less than 1 mm wide shall be limited to its width.

Any air gap of less than 1 mm shall be ignored in computing the total air path.

NOTE 1 Creepage distances are distances in air, measured along the external surface of the insulating material.

NOTE 2 Distances between ballast windings are not measured because they are checked with the endurance test. This applies also to distances between taps.

A metal enclosure shall have an insulating lining in accordance with IEC 60598-1 if, in the absence of such a lining, the creepage distance or clearance between the live parts and the enclosure would be smaller than the value prescribed in the relevant tables.

Lamp controlgear, where the components are so encapsulated in a self-hardening compound bonded to the relevant surfaces that no clearances exist, are not checked.

Printed circuit boards are exempt from the requirements of this clause because they are tested according to clause 14.



**Table 3 – Minimum distances for a.c. (50/60 Hz) sinusoidal voltages**

	RMS working voltage not exceeding					
	V					
	50	150	250	500	750	1 000
<b>Minimum clearance mm</b>						
a) between live parts of different polarity, and						
b) between live parts and accessible metal parts which are permanently fixed to the lamp controlgear, including screws or devices for fixing covers or fixing the lamp controlgear to its support						
– Creepage distances						
Insulation PTI ≥ 600	0,6	1,4	1,7	3	4	5,5
< 600	1,2	1,6	2,5	5	8	10
– Clearances	0,2	1,4	1,7	3	4	5,5
c) between live parts and a flat supporting surface or a loose metal cover, if any, if the construction does not ensure that the values under b) above are maintained under the most unfavourable circumstances						
– Clearances	2	3,2	3,6	4,8	6	8
NOTE 1 PTI (proof tracking index) in accordance with IEC 60112.						
NOTE 2 In the case of creepage distances to parts not energized or not intended to be earthed where tracking cannot occur, the values specified for material with PTI ≥ 600 apply for all materials (in spite of the real PTI).						
For creepage distances subjected to working voltages of less than 60 s duration, the values specified for materials with PTI ≥ 600 apply for all materials.						
NOTE 3 For creepage distances not liable to contamination by dust or moisture, the values specified for materials with PTI ≥ 600 apply (regardless of the real PTI).						
NOTE 4 For lamp controlgear specified in IEC 61347-2-1, accessible metal parts are rigidly placed in relation to live parts.						
NOTE 5 The creepage distances and clearances specified in this clause do not apply to those devices specified in IEC 61347-2-1 which comply with the dimensions specified in IEC 60155. In such instances, the requirements of that standard apply.						

**Table 4 – Minimum distances for non-sinusoidal pulse voltages**

	Rated pulse voltage																	
	peak kV																	
	2,0	2,5	3,0	4,0	5,0	6,0	8,0	10	12	15	20	25	30	40	50	60	80	100
<b>Minimum clearance in mm</b>	1,0	1,5	2	3	4	5,5	8	11	14	18	25	33	40	60	75	90	130	170

For distances subjected to both sinusoidal voltage as well as non-sinusoidal pulses, the minimum required distance shall be not less than the highest value indicated in either table 3 or 4.

Creepage distances shall be not less than the required minimum clearance.

## 17 Screws, current-carrying parts and connections

Screws, current-carrying parts and mechanical connections, the failure of which might cause the lamp controlgear to become unsafe, shall withstand the mechanical stresses occurring in normal use.

*Compliance is checked by inspection and the tests of 4.11 and 4.12 of section 4 of IEC 60598-1.*

## 18 Resistance to heat, fire and tracking

**18.1** Parts of insulating material either retaining live parts in position or providing protection against electric shock shall be sufficiently resistant to heat.

For materials other than ceramic, compliance is checked by subjecting the parts to the ball-pressure test according to section 13 of IEC 60598-1.

**18.2** External parts of insulating material providing protection against electric shock and parts of insulating material retaining live parts in position shall be sufficiently resistant to flame and ignition/fire.

For materials other than ceramic, compliance is checked by the tests of 18.3 or 18.4, as appropriate.

Printed circuit boards are not tested as above, but in accordance with 4.3 of IEC 60249-1.

**18.3** External parts of insulating material providing protection against electric shock shall be subjected for 30 s to the glow-wire test in accordance with IEC 60695-2-1, subject to the following details:

- the test sample shall be one specimen;
- the test specimen shall be a complete lamp controlgear;
- the temperature of the tip of the glow-wire shall be 650 °C;
- any (self-sustaining) flame or glowing of the specimen shall extinguish within 30 s of removal of the glow wire and any flaming drops shall not ignite a piece of tissue paper, as specified in 6.86 of ISO 4046, spread out horizontally 200 mm ± 5 mm below the test specimen.

**18.4** Parts of insulating material retaining live parts in position shall be subjected to the needle-flame test in accordance with IEC 60695-2-2, subject to the following details:

- the test sample shall be one specimen;
- the test specimen shall be a complete lamp controlgear. If it is necessary to take away parts of the lamp controlgear to perform the test, care shall be taken to ensure that the test conditions are not significantly different from those occurring in normal use;
- the test flame is applied to the centre of the surface to be tested;

- the duration of application is 10 s;
- any self-sustaining flame shall extinguish within 30 s of removal of the gas flame, and any flaming drops shall not ignite a piece of tissue paper as specified in 6.86 of ISO 4046, spread out horizontally 200 mm ± 5 mm below the test specimen.

**18.5** Lamp controlgear intended for building into luminaires other than ordinary, independent lamp controlgear, and lamp controlgear having insulation subject to starting voltages with a peak value higher than 1 500 V shall be resistant to tracking.

For materials other than ceramic, compliance is checked by subjecting the parts to the tracking test according to section 13 of IEC 60598-1.

## **19 Resistance to corrosion**

Ferrous parts, the rusting of which might cause the lamp controlgear to become unsafe, shall be adequately protected against rusting.

*Compliance is checked by the test of 4.18.1 of section 4 of IEC 60598-1.*

Protection by varnish is deemed to be adequate for the outer surfaces.

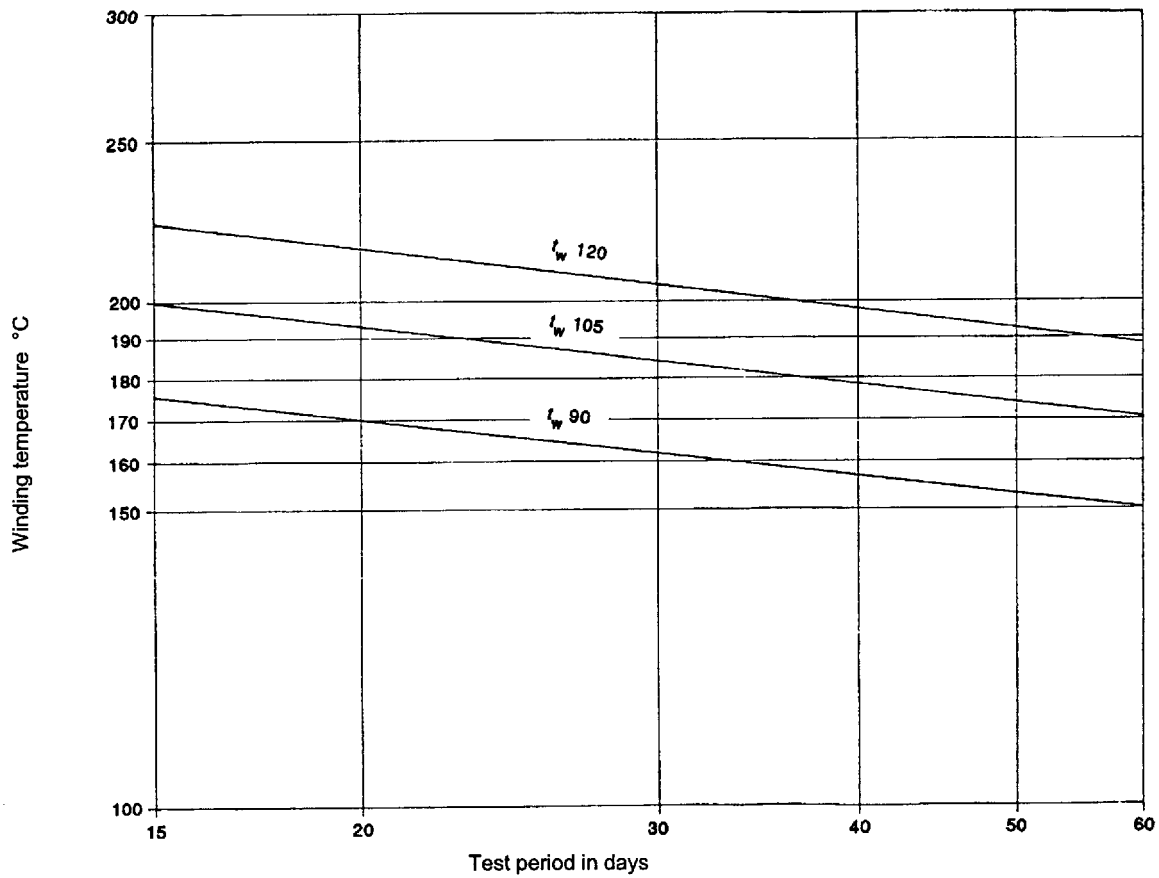

IEC 586/2000

NOTE These curves are for information only and illustrate equation (2) using a constant S of 4 500 (see annex E).

Figure 1 – Relation between winding temperature and endurance test duration

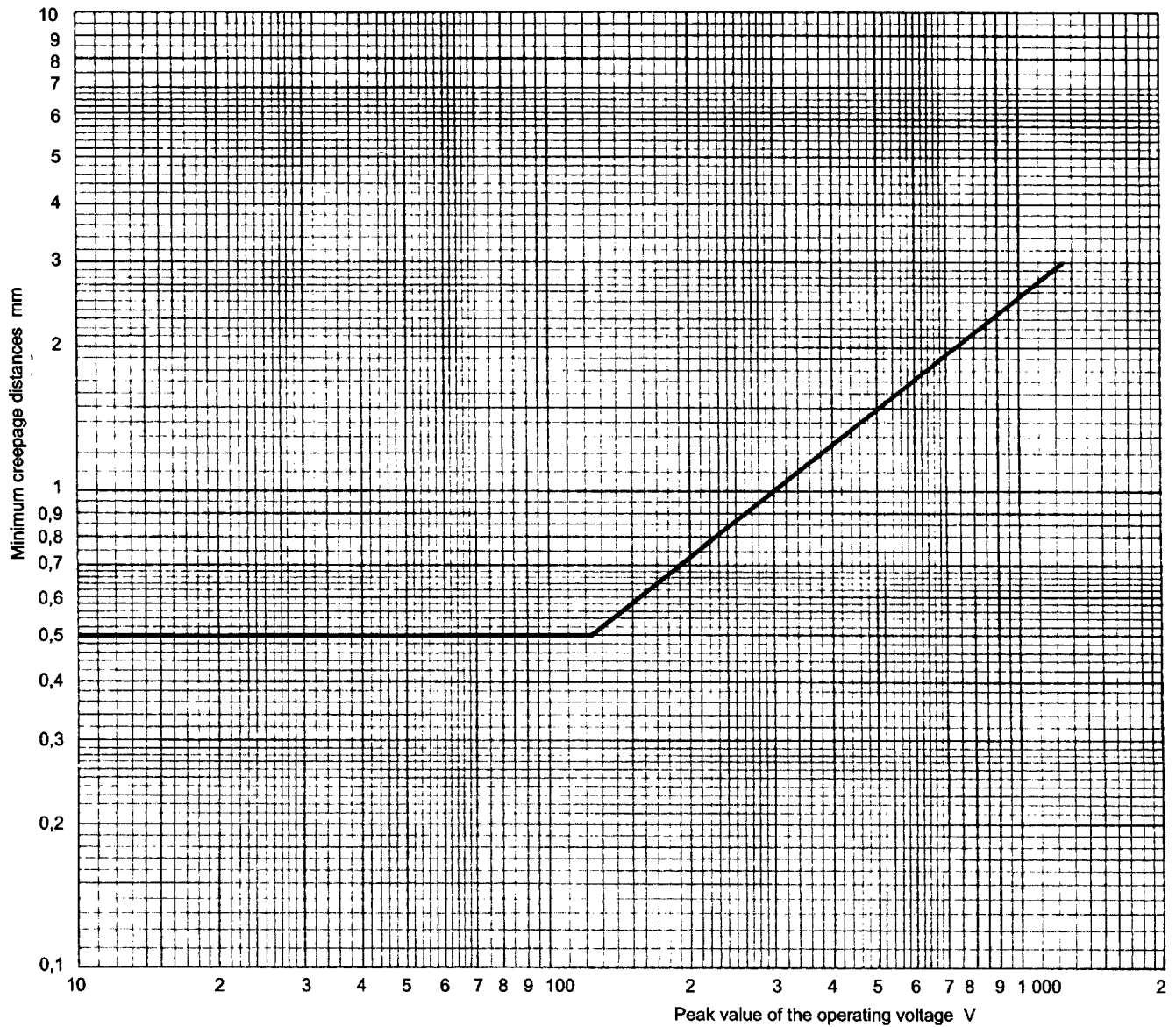

IEC 587/2000

**Figure 2 – Creepage distances between conductors on printed boards not conductively connected to the supply mains**

## Annex A (normative)

### Test to establish whether a conductive part is a live part which may cause an electric shock

In order to determine whether a conductive part is a live part which may cause an electric shock, the lamp controlgear is operated at rated voltage and nominal supply frequency, and the following tests are conducted.

**A.1** The part concerned is a live part if a current of more than 0,7 mA (peak) or 2 mA d.c. is measured.

For frequencies above 1 kHz, the limit of 0,7 mA (peak) is multiplied by the value of the frequency in kilohertz, but the result shall not exceed 70 mA (peak).

*The current flowing between the part concerned and earth is measured.*

*Compliance is checked by measurement in accordance with figure 4 and 7.1 of IEC 60990.*

**A.2** The voltage between the part concerned and any accessible part is measured, the measuring circuit having a non-inductive resistance of 50 k $\Omega$ . The part concerned is a live part if a voltage of more than 34 V (peak) is measured.

*For the above test, one pole of the test supply shall be at earth potential.*

## Annex B (normative)

### Particular requirements for thermally protected lamp controlgear

#### B.1 Introductory remark

Two different categories of thermally protected lamp controlgear are covered by this annex. The first category comprises "class P" USA lamp controlgear, referred to in this standard as "protected lamp controlgear", which are intended to prevent lamp controlgear overheating under any conditions of use including protection of the luminaire mounting surface against overheating due to end-of-life effects.

The second category comprises "temperature declared thermally protected lamp controlgear". This category provides thermal protection of the mounting surface which, depending on the marked operating temperature of the thermal protection in combination with the luminaire construction, provides protection against overheating due to end-of-life effects on the lamp controlgear.

**NOTE** A third category of thermal lamp controlgear protection is recognized where the thermal protection of the mounting surface is achieved by a thermal protector external to the lamp controlgear. Relevant requirements may be found in IEC 60598-1.

The clauses listed in this annex supplement the corresponding clauses in the main part of the standard. Where there is no corresponding clause or subclause in this annex, the clause or subclause of the main part applies without modification.

#### B.2 Scope

This annex applies to lamp controlgear for discharge lamps, intended to be built into luminaires and incorporating a means of thermal protection that is intended to disconnect the supply circuit to the lamp controlgear before the lamp controlgear case temperature exceeds the specified limits.

#### B.3 Definitions

##### B.3.1

##### "class P" thermally protected lamp controlgear



lamp controlgear incorporating a thermal protector which is intended to prevent overheating under any conditions of use and which will protect the luminaire mounting surface against overheating due to end-of-life effects

##### B.3.2

##### temperature declared thermally protected lamp controlgear



lamp controlgear incorporating means of protection against overheating to prevent the lamp controlgear case temperature under any conditions of use from exceeding the indicated value

**NOTE** The dots in the triangle are replaced by the value of the rated maximum case temperature in degrees Celsius at any place on the outer surface of the lamp controlgear case, as claimed by the manufacturer under the conditions in clause B.9.

Lamp controlgear marked with values up to 130 provide protection against overheating due to end-of-life effects in accordance with luminaire marking requirements. See IEC 60598-1.

If the value exceeds 130,  marked luminaires shall in addition be tested in accordance with IEC 60598-1 with respect to luminaires without temperature sensing controls.

### B.3.3

#### rated opening temperature

the no-load temperature at which a protector is designed to open

## B.4 General requirements for thermally protected lamp controlgear

Thermal protectors shall be an integral part of lamp controlgear and located so as to be protected against mechanical damage. Renewable parts, if any, shall only be accessible by means of a tool.

If functioning of the protection means depends on polarity, then for cord-connected equipment where the plug is not polarized, the protection shall be in both leads.

*Compliance is checked by inspection and by the tests of IEC 60730-2-3 or IEC 60691, as appropriate.*

## B.5 General notes on tests



The appropriate number of specially prepared samples according to clause B.9 shall be submitted.

Only one sample need be subjected to the most onerous fault condition described in B.9.2 and only one sample need be subjected to the conditions described in B.9.3 or B.9.4. In addition, for both protected and temperature-declared lamp controlgear, at least one lamp controlgear shall be submitted, prepared to represent the most onerous of the fault conditions described in B.9.2.

## B.6 Classification

Lamp controlgear are classified according to B.6.1 or B.6.2.

### B.6.1 According to the class of protection

- a) "class P" thermally protected lamp controlgear, symbol  ;
- b) temperature declared thermally protected lamp controlgear, symbol .



### B.6.2 According to the type of protection

- a) automatic resetting (cyclic) type;
- b) manual resetting (cyclic) type;
- c) non-renewable, non-resetting (fuse) type;
- d) renewable, non-resetting (fuse) type;
- e) other type of protective method providing equivalent thermal protection.



## B.7 Marking

**B.7.1** Lamp controlgear incorporating means of protection against overheating shall be marked according to the class of protection:

- the symbol  for "class P" thermally protected lamp controlgear;
- the symbol  for temperature declared thermally protected lamp controlgear, values increasing in multiples of 10.

The terminal(s) to which the protector(s) is(are) connected shall be identified by this symbol.

In addition, for renewable protectors, the marking shall include the type of protector to be used.

NOTE 1 This marking is required by the luminaire manufacturer to ensure that the marked terminal is not connected to the lamp side of the lamp controlgear.

NOTE 2 Local wiring rules may require the protector to be connected in the line conductor. This is essential in class I equipment where polarized supplies are used.

**B.7.2** In addition to the above marking, the lamp controlgear manufacturer shall declare the type of protection in accordance with clause B.6.

## B.8 Thermal endurance of windings

Lamp controlgear incorporating a thermal protector shall comply with the thermal endurance test of windings with the protector short-circuited.

NOTE For type testing, the manufacturer may be asked to supply samples with short-circuited protectors.

## B.9 Lamp controlgear heating

### B.9.1 Preselection test

*Before starting the tests of this clause, the lamp controlgear shall be placed (non-energized) for at least 12 h in an oven, the temperature of which is maintained at 5 K less than the rated operating temperature of the protector.*

*In addition, lamp controlgear with thermal fuses are allowed to cool to a temperature at least 20 K less than the rated operating temperature of the protector before being removed from the oven.*

*At the end of this period, a small current, for example not more than 3 % of the nominal supply current of the lamp controlgear, shall be passed through the lamp controlgear in order to determine whether the protector is closed.*

*Lamp controlgear in which the protector has operated shall not be used for further testing.*

### B.9.2 "Class P" thermally protected lamp controlgear

These lamp controlgear are limited to a maximum case temperature of the lamp controlgear of 90 °C, a rated maximum winding temperature ( $t_w$ ) of 105 °C and a capacitor rated maximum operating temperature ( $t_c$ ) of 70 °C.

NOTE These lamp controlgear are suited to present practice in the USA.

The lamp controlgear is operated at thermal equilibrium under normal conditions in the test enclosure of which a typical example is described in annex D, at an ambient temperature of  $40_{-5}^{+0}$  °C.

The protector shall not open under these conditions of operation.

The most onerous of the following fault conditions shall then be introduced and applied throughout the complete test.

To obtain these conditions, specially prepared lamp controlgear will be necessary.

**B.9.2.1** For transformers, the following relevant abnormal conditions apply (in addition to those specified in annex C of IEC 60598-1):

- a) For lamp controlgear specified in IEC 61347-2-8
  - the outer 10 % of the turns of primary winding is short-circuited;
  - the outer 10 % of the turns of any secondary power winding is short-circuited;
  - any power capacitor short-circuited, if such condition will not short-circuit the ballast primary winding.
- b) For lamp controlgear specified in IEC 61347-2-9
  - the outer 20 % of the turns of primary winding is short-circuited;
  - the outer 20 % of the turns of any secondary power winding is short-circuited;
  - any power capacitor short-circuited, if such condition will not short-circuit the ballast primary winding.

**B.9.2.2** For chokes, the following abnormal conditions apply (in addition to those specified in annex C of IEC 60598-1):

- a) For lamp controlgear specified in IEC 61347-2-8
  - the outer 10 % of the turns of each winding is short-circuited;
  - a series capacitor is short-circuited, if applicable.
- b) For lamp controlgear specified in IEC 61347-2-9
  - the outer 20 % of the turns of each winding is short-circuited;
  - a series capacitor is short-circuited, if applicable.

Three cycles of heating and cooling shall be applied for the purpose of this measurement. For non-resetting type protectors, only one cycle shall be applied on each specially prepared lamp controlgear.

Temperatures on the case of the lamp controlgear shall continue to be measured after the protector opens. Except when testing for protector reclosing temperatures, the test may be discontinued when case temperatures start to decrease following the opening of the protector, or when the specified temperature limit is exceeded.

**NOTE** If the case reaches a temperature not exceeding 110 °C and either remains at that temperature or starts to decrease, the test may be discontinued after 1 h of operation after the peak temperature is first reached.

*During the test, the temperature on the case of the lamp controlgear shall not exceed 110 °C and shall be no more than 85 °C when the protector recloses the circuit (with a resetting type protector), except that, during any cycle of operation of the protector during the test, the case temperature may be more than 110 °C, provided that the length of time between the instant when the case temperature first exceeds the limit and the instant of attainment of the maximum temperature indicated in table B.1 does not exceed the time correspondingly indicated in that table.*

*The temperature on the enclosure of a capacitor provided as part of such lamp controlgear shall be no more than 90 °C except that the capacitor temperature may be more than 90 °C when the case temperature is more than 110 °C.*

**Table B.1 – Thermal protection operation**

Maximum temperature of the lamp controlgear case °C	Maximum time for attainment of the maximum temperature from 110 °C min
Over 150	0
Between 145 and 150	5,3
Between 140 and 145	7,1
Between 135 and 140	10
Between 130 and 135	14
Between 125 and 130	20
Between 120 and 125	31
Between 115 and 120	53
Between 110 and 115	120

**B.9.3 Temperature declared thermally protected lamp controlgear as specified in IEC 61347-2-8, with a rated maximum case temperature of 130 °C or lower**

The lamp controlgear is operated at thermal equilibrium under normal conditions in the test enclosure described in annex D, in an ambient temperature such that a winding temperature of  $(t_w + 5)$  °C is obtained.

The protection means shall not operate under these conditions.

The most onerous of the fault conditions described in B.9.2 shall then be introduced and applied throughout the complete test.

**NOTE** It is permitted to operate the lamp controlgear at a current producing a winding temperature equivalent to that of the most onerous of the fault conditions described in B.9.2.

*During the test, the temperature on the case of the lamp controlgear shall not exceed 135 °C and shall be no more than 110 °C when the protector recloses the circuit (with a resetting type protector). However, during any cycle of operation of the protector during the test, the case temperature may be more than 135 °C, provided that the length of time between the instant when the case temperature first exceeds the limit and the instant of attainment of the maximum temperature indicated in table B.2 does not exceed the time corresponding to that indicated in that table.*

The temperature on the enclosure of a capacitor provided as part of such a lamp controlgear shall be no more than 50 °C or  $t_c$  under conditions of normal operation and not more than 60 °C or  $(t_c + 10)$  °C under conditions of abnormal operation for capacitors with or without indication of rated maximum operating temperature ( $t_c$ ) respectively.

**Table B.2 – Thermal protection operation**

Maximum temperature of the lamp controlgear case °C	Maximum time for attainment of the maximum temperature from 135 °C min
Over 180	0
Between 175 and 180	15
Between 170 and 175	20
Between 165 and 170	25
Between 160 and 165	30
Between 155 and 160	40
Between 150 and 155	50
Between 145 and 150	60
Between 140 and 145	90
Between 135 and 140	120

**B.9.4 Temperature declared thermally protected lamp controlgear as specified in IEC 61347-2-8 with a rated maximum case temperature exceeding 130 °C**

- a) *The lamp controlgear shall be operated at thermal equilibrium under conditions as specified in D.4 at a short-circuit current producing a winding temperature of  $(t_w + 5)$  °C.*

*The protection means shall not open under this condition.*

- b) *The lamp controlgear shall then be operated at a current producing a winding temperature identical to that under the most onerous of the fault conditions described in B.9.2.*

*During the test, the lamp controlgear case temperature shall be measured.*

*Then, if necessary, the current through the windings shall be increased slowly and continuously until the protection means operates.*

*Time intervals and increments in current shall be such that thermal equilibrium between winding temperatures and lamp controlgear surface temperatures is achieved as far as is possible.*

*During the test, the highest temperature of the lamp controlgear surface shall be continuously measured.*

*For lamp controlgear fitted with automatic resetting thermal cut-outs/protectors (see B.6.2a) or protective mechanism of another type (see B.6.2e)), the test shall be continued until stable surface temperature is achieved.*

*The automatic-resetting thermal cut-out/protector shall work three times by switching the lamp controlgear off and on under the given conditions.*

*For lamp controlgear fitted with manual reset thermal cut-outs/protectors, the test shall be repeated three times allowing a 30-min interval between tests. At the end of each 30 min interval, the cut-outs/protectors shall be reset.*

*For lamp controlgear fitted with non-renewable, non-resetting type, and for lamp controlgear with renewable type of thermal protectors, only one test is carried out.*

*Compliance is achieved if the highest temperature of any part of the lamp controlgear surface does not exceed the marked value.*

*An overshoot of 10 % of the declared value is permissible within 15 min after the protection means has operated. After that period, the declared value shall not be exceeded.*

#### **B.9.5 Temperature declared thermally protected lamp controlgear as specified in IEC 61347-2-9**

- a) *The lamp controlgear shall be operated at thermal equilibrium, under conditions as specified in H.12, at a short-circuit current producing a winding temperature of  $(t_w + 5)$  °C. The protector shall not open under this condition.*

*The lamp controlgear shall then be operated at a current producing a winding temperature identical to that under the most onerous of the fault conditions described in B.9.2. During the test, the lamp controlgear case temperature shall be measured.*

*The circuit subjected to abnormal conditions shall be operated with a slowly and steadily increasing current through the windings until the thermal protector operates. Time intervals and increments in current shall be such that thermal equilibrium between winding temperatures and lamp controlgear surface temperatures is achieved as far as is practicable.*

*During the test, the highest temperature of any part of the lamp controlgear surface shall be continuously measured.*

*For lamp controlgear fitted with automatic resetting thermal protectors (see B.6.2a)), or with a protective method of another type (see B.6.2e)), the test shall be continued until a stable surface temperature is achieved. The automatic setting thermal protector shall work three times by switching the lamp controlgear off and on under the given conditions.*

*For lamp controlgear fitted with a manual resetting thermal protector, the test shall be repeated three times allowing a 30 min interval between tests. At the end of each 30 min interval, the cut-outs shall be reset.*

*For lamp controlgear fitted with non-renewable, non-resetting type, and for ballasts with renewable types of thermal protectors, only one test is carried out.*

*For lamp controlgear where a combination of the protective devices mentioned is used, the lamp controlgear shall be tested as for the protection device that provides the primary protection for temperature control, as declared by the manufacturer.*

*Compliance is achieved if the highest temperature of any part of the lamp controlgear surface does not exceed the marked value.*

*An overshoot of 10 % of the marked value is permissible within 15 min after the protection means has operated. After that period, the marked value shall not be exceeded.*

## Annex C (normative)

### Particular requirements for electronic lamp controlgear with means of protection against overheating

#### C.1 Scope

This annex applies to electronic lamp controlgear incorporating a means of thermal protection that is intended to open the supply circuits to the lamp controlgear before the lamp controlgear case temperature exceeds the declared limits.

#### C.2 Definition

##### C.2.1 Temperature declared thermally protected lamp controlgear

lamp controlgear incorporating means of protection against overheating to prevent the lamp controlgear case temperature exceeding the indicated value

NOTE The three dots in the triangle are replaced by the value of the rated maximum case temperature in degrees Celsius at any place on the outer surface of the lamp controlgear case as claimed by the manufacturer under the conditions in clause C.7.

Lamp controlgear marked with values up to 130 provide protection against overheating due to end-of-life effects in accordance with luminaire  marking requirements. See IEC 60598-1.

If the value exceeds 130,  marked luminaires shall, in addition, be tested in accordance with IEC 60598-1 with respect to luminaires without temperature sensing controls.

#### C.3 General requirements for electronic lamp controlgear with means of protection against overheating

**C.3.1** Thermal protection means shall be an integral part of lamp controlgear and located so as to be protected against mechanical damage. Renewable parts, if any, shall be accessible only by means of a tool.

If the functioning of the protection means depends on polarity, then, for cord-connected equipment where the plug is not polarized, the protection shall be in both leads.

*Compliance is checked by inspection and by the tests of IEC 60730-2-3 or IEC 60691, as appropriate.*

**C.3.2** The circuit breaking of the protection means shall not give rise to any fire risk.

*Compliance is checked by the tests of clause C.7.*

#### C.4 General notes on tests

The appropriate number of specially prepared samples according to clause C.7 shall be submitted.

Only one sample need be subjected to the most onerous fault conditions described in C.7.2.

#### C.5 Classification

Thermally protected lamp controlgear are classified according to the type of protection:

- a) automatic resetting type;
- b) manual resetting type;
- c) non-renewable, non-resetting type;
- d) renewable, non-resetting type;
- e) protective method of another type providing equivalent thermal protection.

#### C.6 Marking

Thermally protected lamp controlgear shall be marked as follows.

**C.6.1** The symbol  is used for temperature declared thermally protected lamp controlgear, values increasing in multiples of 10.

**C.6.2** In addition to the above marking, the lamp controlgear manufacturer shall declare the type of protection in accordance with clause C.5. This information may be given in the manufacturer's catalogue or similar.

#### C.7 Limitation of heating

##### C.7.1 Preselection test

Before starting the tests of this clause, the lamp controlgear shall be placed (non-energized) for at least 12 h in an oven the temperature of which is maintained at 5 K less than the case temperature  $t_c$ .

Lamp controlgear in which the protector has operated shall not be used for further testing.

##### C.7.2 Functioning of the protection means

The lamp controlgear is operated at thermal equilibrium under normal conditions in the test enclosure described in annex D, at an ambient temperature such that a case temperature of  $(t_c^{+0}_{-5})$  °C is obtained.

The protection means shall not operate under these conditions.

The most onerous of the fault conditions described in 14.1 to 14.4 shall then be introduced and be applied throughout the complete test.

If the lamp controlgear under test contains windings such as filter coils for suppressing harmonics according to 12.1 of IEC 60929, which are connected to mains supply, the output connections of these windings shall be short-circuited and the remaining part of the lamp controlgear shall be operated as under normal conditions. Filter coils for radio interference suppression are not subjected to the test.

NOTE This can be realized by specially prepared test samples.

Then, if necessary, the current through the windings shall be increased slowly and continuously until the protection means operates. Time intervals and increments in current shall be such that the thermal equilibrium between winding temperatures and lamp controlgear surface temperatures is achieved as far as possible. During the test, the highest temperature of the lamp controlgear surface shall be continuously measured.

For lamp controlgear fitted with automatic-resetting thermal protectors (see C.5a)), or a protective method of another type (see C.5e)), the test shall be continued until a stable surface temperature is achieved.

The automatic-resetting thermal protector shall work three times by switching the lamp controlgear off and on under the given conditions.

For lamp controlgear fitted with manual reset thermal protectors, the test shall be repeated six times allowing a 30-min interval between tests. At the end of each 30 min interval, the protectors shall be reset.

For lamp controlgear fitted with a non-renewable, non-resetting type protectors and for lamp controlgear with renewable type thermal protectors, only one test is carried out.

*Compliance is achieved if the highest temperature of any part of the lamp controlgear surface does not exceed the marked value.*

An overshoot of 10 % of the marked value is permissible within 15 min after the protection means has operated. After that period, the marked value shall not be exceeded.



## Annex D (normative)

### Requirements for carrying out the heating tests of thermally protected lamp controlgear

#### D.1 Test enclosure

The heating tests are made in an enclosure in which the temperature of the ambient air is maintained as specified (see figure D.1). The entire test enclosure shall be constructed of heat resistant material 25 mm thick. The test compartment of this enclosure shall have internal dimensions of 610 mm × 610 mm × 610 mm. The floor of the test compartment shall measure 560 mm × 560 mm, permitting an air space of 25 mm all around the platform for circulation of the heated air. A 75 mm heater compartment shall be provided below the floor of the test area for the heating elements. One side of the test compartment may be removable, but shall be so constructed that it can be securely fastened to the remainder of the enclosure. One of the sides shall have a 150 mm square opening located centrally at the bottom edge of the test compartment, and the enclosure so constructed that the only possibility of air circulation will be through this opening. The opening shall be covered by an aluminium shield as shown in figure D.1.

#### D.2 Heating of enclosure

The heat source used for the test enclosure described above shall consist of four 300 W strip heaters having approximate heating surface dimensions of 40 mm × 300 mm. These elements shall be connected in parallel to the supply source. The elements shall be mounted in the 75 mm heater compartment midway between the test compartment floor and the base, and so arranged that they form a square with the outside edge of each element 65 mm from the adjacent inside wall of the enclosure. The elements shall be controlled by a suitable thermostat.

#### D.3 Lamp controlgear operating conditions

During the test, the frequency of the supply circuit shall be the rated frequency of the lamp controlgear, and the voltage of the supply circuit shall be the rated supply voltage of the lamp controlgear. During the test, the temperature in the enclosure shall be maintained at  $40_{-5}^{+0}$  °C; prior to the test, the lamp controlgear (not energized) shall be placed in the chamber for a sufficient interval of time to allow all parts to attain the temperature of the air therein. If the temperature in the chamber at the end of the test differs from that at the beginning of the test, this temperature differential shall be taken into account in determining the temperature rise of the components of the lamp controlgear. The lamp controlgear shall supply the number and size of lamps for which it is intended. Lamps shall be placed outside the enclosure.

#### D.4 Lamp controlgear position in the enclosure

During the test, the lamp controlgear shall be in its normal operating position supported 75 mm above the floor of the test compartment by two 75 mm wooden blocks, and shall be centrally located with respect to the sides of the enclosure. Electrical connections may be brought out of the enclosure through the 150 mm square opening illustrated in figure D.1. During the test, the enclosure shall be so located that the shielded opening is not exposed to draughts or rapid air currents.

### **D.5 Temperature measurements**

The average ambient temperature in the enclosure is assumed to be the average air temperature at positions not less than 76 mm from the nearest wall and on a level with the centre of the lamp controlgear.

The temperature is usually measured by a glass thermometer. An alternative sensor is a thermocouple or 'thermistor' attached to a small metal vane shielded against radiation.

Temperatures on the case are usually measured by means of thermocouples. A temperature is considered to be constant when three successive readings, taken at intervals of 10 % of the previously elapsed duration of the test (but not less than 5 min intervals), indicate no change.

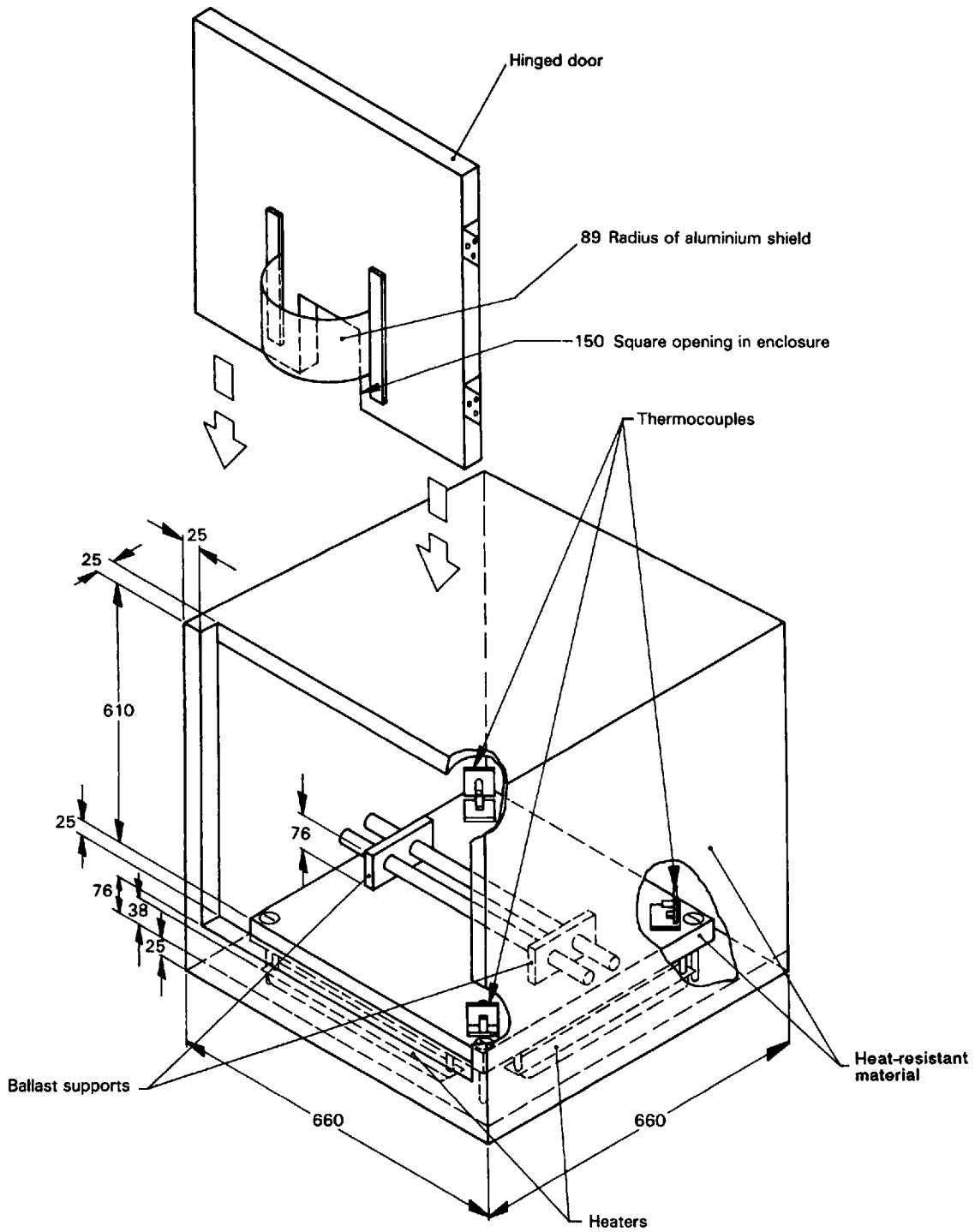

IEC 588/2000

Dimensions in millimetres

Figure D.1 – Exemple of heating enclosure for thermally protected ballasts

## Annex E (normative)

### Use of constant $S$ other than 4 500 in $t_w$ tests

**E.1** The tests outlined in this annex are intended to enable the manufacturer to prove a claimed value of  $S$  other than 4 500.

Theoretical test temperatures  $T$  for use in ballast endurance tests are calculated from equation (2) given in clause 13.

If no claim is made to the contrary,  $S$  shall be taken to be 4 500 but a manufacturer may claim the use of any of the values in table 2 if this can be justified by procedures A or B below.

If the use of a constant other than 4 500 for a particular ballast has been proved on the basis of procedures A or B, then that constant may be used in endurance tests for that ballast and others using the same construction and materials.

#### **E.2 Procedure A**

The manufacturer submits experimental data relating life expectancy to winding temperature for the ballast design concerned, based on enough samples, but no fewer than 30.

From this data, the regression line relating  $T$  to  $\log L$ , together with the 95 % confidence lines associated with it, are computed.

A straight line is then drawn through the points where the 10 days and 120 days abscissae intersect the upper and lower 95 % confidence lines respectively. See figure E.1 for a typical presentation. If the inverse of the slope of this line is greater than, or equal to, the claimed value of  $S$ , then the latter has been proved within 95 % confidence limits. For failure criteria, see procedure B.

NOTE 1 The points at 10 days and 120 days represent the smallest interval needed for the application of the confidence lines. Other points may be used provided a similar or greater interval is covered.

NOTE 2 Information in respect of the techniques involved and the method of calculating regression lines and confidence limits are given in IEC 60216 and in IEEE 101.

#### **E.3 Procedure B**

The testing authority shall test 14 new ballasts submitted by the manufacturer in addition to those required for the endurance test, divided at random into two groups of seven. The manufacturer shall state the value of  $S$  claimed and the test temperature  $T_1$  – required to achieve a nominal average ballast life of 10 days – together with the corresponding test temperature  $T_2$  – for a nominal average ballast life of at least 120 days – calculated using  $T_1$ , and the claimed value of  $S$  in the following version of equation (2):

$$\frac{1}{T_2} = \frac{1}{T_1} + \frac{1}{S} \log \frac{120}{10} \quad \text{or} \quad \frac{1}{T_2} = \frac{1}{T_1} + \frac{1,079}{S} \quad (\text{E.1})$$

where

$T_1$  is the theoretical test temperature in kelvins for 10 days;

$T_2$  is the theoretical test temperature in kelvins for 120 days;

$S$  is the claimed constant.

Endurance tests are then carried out using the basic method described in clause 13 on the two groups of seven ballasts, based on the theoretical temperature  $T_1$  (test 1) and  $T_2$  (test 2), respectively.

If the current deviates by more than 15 % from the initial value measured 24 h after the commencement of the test, the test shall be repeated at a lower temperature. The duration of the test is calculated with the help of equation (2). Ballasts are considered to have failed if during operation in the oven

- a) the ballast becomes open-circuit;
- b) breakdown of the insulation occurs, as indicated by the operation of a fast-acting fuse with a current rating of 150 % to 200 % of the initial supply current measured after 24 h.

Test 1, the duration of which shall be equal to, or greater than, 10 days, is continued until all the ballasts have failed and the mean life  $L_1$  has been calculated from the mean of the logarithm of the individual lives at temperature  $T_1$ . From this, the corresponding mean life  $L_2$  at temperature  $T_2$  is calculated with the help of another arrangement (E.2) of equation (2):

$$L_2 = L_{1\text{exp}} \left[ \frac{S}{\log_e} \left( \frac{1}{T_2} - \frac{1}{T_1} \right) \right] \quad (\text{E.2})$$

NOTE 1 Care should be taken to ensure that the failure of one or more of the ballasts does not affect the temperature of the remaining ballast on test.

Test 2 is continued until such time as the mean life at temperature  $T_2$  exceeds  $L_2$ ; this result implies that the constants for the sample is at least that claimed. However, if all the samples in test 2 fail before the mean life reaches  $L_2$ , then the constant  $S$  claimed for the samples has not been verified.

The test lives shall be normalized from the actual test temperature to the theoretical test temperature using the claimed constant  $S$ .

NOTE 2 It is not generally necessary to continue test 2 until all the ballasts have failed. Calculation of the necessary duration of the test is simple but needs to be updated whenever a failure occurs.

In the case of ballasts incorporating temperature-sensitive materials, a nominal ballast life of 10 days might not be appropriate. In such cases, the manufacturer may adopt a longer life providing this is shorter than the appropriate endurance test period, for example, 30, 60, 90 or 120 days. In such cases, the longer nominal ballast life shall be at least 10 times that of the shorter (for example, 15/150 days, 18/180 days, etc.).

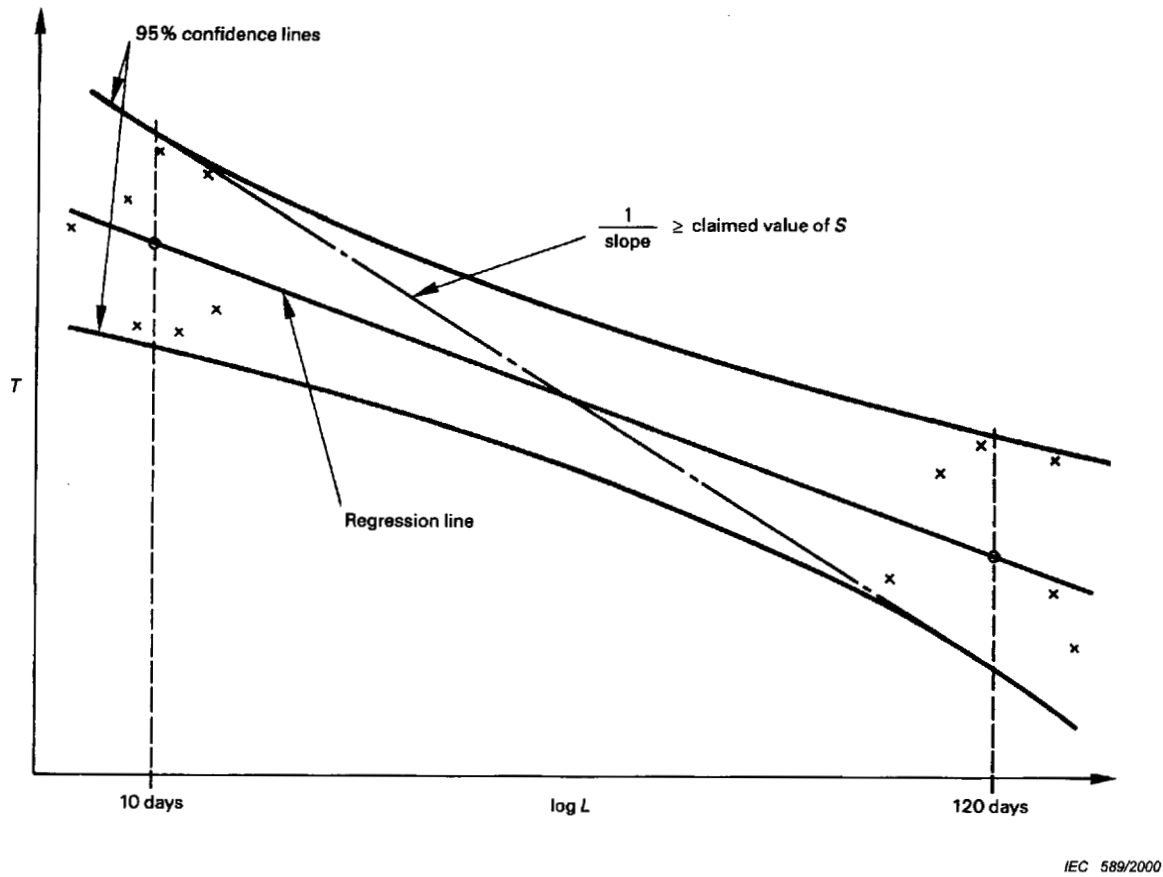

Figure E.1 – Assessment of claimed value of S

## Annex F (normative)

### Draught-proof enclosure

The following recommendations refer to the construction and use of a suitable draught-proof enclosure, as required for the test of lamp controlgear heating. Alternative constructions for draught-proof enclosures are permitted if it is established that similar results are obtained.

The draught-proof enclosure should be rectangular, with a double skin on top and on at least three sides, and with a solid base. The double skins should be of a perforated metal, spaced apart by approximately 150 mm, with regular perforations of 1 mm to 2 mm in diameter, occupying about 40 % of the whole area of each skin.

The internal surfaces should be painted with a matt paint. The three principal internal dimensions should each be at least 900 mm. There should be a clearance of at least 200 mm between the internal surfaces and the top and four sides of the largest lamp controlgear for which the enclosure is designed.

**NOTE** If it is required to test two or more sets of lamp controlgear in a large enclosure, care is taken that radiation from one lamp controlgear cannot affect any other.

There should be a clearance of at least 300 mm above the top of the enclosure and around the perforated sides. The enclosure should be at a location protected, as far as possible, from draughts and sudden changes in air temperature. It should also be protected from sources of radiant heat.

Lamp controlgear under test should be positioned as far as possible from the five internal surfaces of the enclosure, the lamp controlgear with wooden blocks standing on the bottom of the enclosure, as required by annex D.

## Annex G (normative)

### Explanation of the derivation of the values of pulse voltages

**G.1** The pulse voltage rise time  $T$  is intended to shock-excite the input filter of the inverter and produce a "worst-case" effect. The time of  $5 \mu\text{s}$  is chosen to be less than the rise time of a very poor input filter.

$$T = \pi \sqrt{LC} \quad (\text{G.1})$$

where

$L$  is the input filter inductance;

$C$  is the input filter capacitance.

**G.2** The peak value for long-duration pulse voltages is given as two times the design voltage. See figure G.2.

For 13 V and 26 V inverters, this gives a voltage applied to the inverter as follows:

$$(13 \times 2) + 15 = 41 \text{ and}$$

$$(26 \times 2) + 30 = 82.$$

NOTE Fifteen and 30 are the maximum values of the voltage ranges of 13 V and 26 V inverters respectively.

**G.3** The peak value for short-duration pulse voltages is given as eight times the design voltage.

For 13 V and 26 V inverters this gives a voltage applied to the inverter as follows:

$$(13 \times 8) + 15 = 119 \text{ V and}$$

$$(26 \times 8) + 30 = 238 \text{ V.}$$

NOTE Fifteen and 30 are the maximum values of the voltage ranges of 13 V and 26 V inverters respectively.

**G.4** Explanations referring to the choice of values for the components of the circuit for measuring short-duration pulse energy illustrated in figure G.1.

The discharge shall be made aperiodic in order that the Zener diode receives one pulse only. Consequently, the resistance  $R$  shall be sufficiently large to ensure that

- a) the influence of the self-inductance  $L$  of the circuit, due to the wiring, is sufficiently small; this implies that the time-constant  $L/R$  is definitely smaller than the time constant  $RC$ ;
- b) the maximum value of the current (which may be assessed by  $(V_{pk} - V_Z)/R$ ) should be compatible with the good operation of the Zener diode.

On the other hand, this resistance  $R$  should not be too large if the pulse has to remain short-lived.



With a total inductance of 14 μH to 16 μH (as indicated in the notes to figure G.1) and the values for C indicated below, it appears that the previous conditions may be fulfilled with values of R of the order of magnitude of 20 Ω for an inverter whose design voltage is 13 V rising to about 200 Ω for a design voltage of 110 V.

It should be noted that it is not necessary to insert a separate inductance L in the circuit of figure G.1.

Assuming an aperiodic discharge, the value of the capacity C is related to the energy E<sub>Z</sub> applied to the Zener diode (which takes the place of the inverter) and to the voltages involved by the expression:

$$C = \frac{E_Z}{(V_{pk} - V_Z - V_{CT}) \times V_Z} \quad (G.2)$$

where

V<sub>pk</sub> is the voltage initially applied to capacitor C;

V<sub>Z</sub> is the voltage of the Zener diode;

V<sub>CT</sub> is the final voltage on capacitor C<sub>T</sub>.

Let us denote by

V<sub>d</sub> the design voltage of the inverter to be tested;

V<sub>max</sub> the maximum value of its rated voltage range (1,25 V<sub>d</sub>);

one will choose

V<sub>Z</sub> = V<sub>max</sub> (the best possible approximation);

V<sub>pk</sub> = 8 V<sub>d</sub> + V<sub>max</sub>

and, moreover, V<sub>CT</sub> will remain equal to or less than 1 V.

This last condition allows this voltage V<sub>CT</sub> to be neglected with respect to the difference (V<sub>pk</sub> - V<sub>Z</sub>) and one may thus write

$$C = \frac{E_Z}{(V_{pk} - V_Z) \times V_Z} \quad (G.3)$$

With the values for the voltages indicated above and with the prescribed conditions E<sub>Z</sub> = 1 mJ, the expression of C becomes

$$C (\mu F) = \frac{125}{V_d \times V_{max}} \quad (G.4)$$

On the other hand, a minimum value for the capacity C<sub>T</sub> may be computed starting from

$$E_Z = C_T V_{CT} V_Z \quad (G.5)$$

and, adopting 1 mJ for E<sub>C</sub> and 1 V for V<sub>CT</sub>, we are led to

$$C_T (\mu\text{F}) + \frac{1\ 000}{V_{\text{max}}} \quad (\text{G.6})$$

Considering the case where  $V_{\text{max}} = 1,25 V_d$ , the values of capacities  $C$  and  $C_T$  may then be expressed as a function of the design voltage  $V_d$  as follows:

$$C (\mu\text{F}) + \frac{100}{(V_d)^2} \quad (\text{G.7})$$

and

$$C_T (\mu\text{F}) + \frac{800}{V_d} \quad (\text{G.8})$$

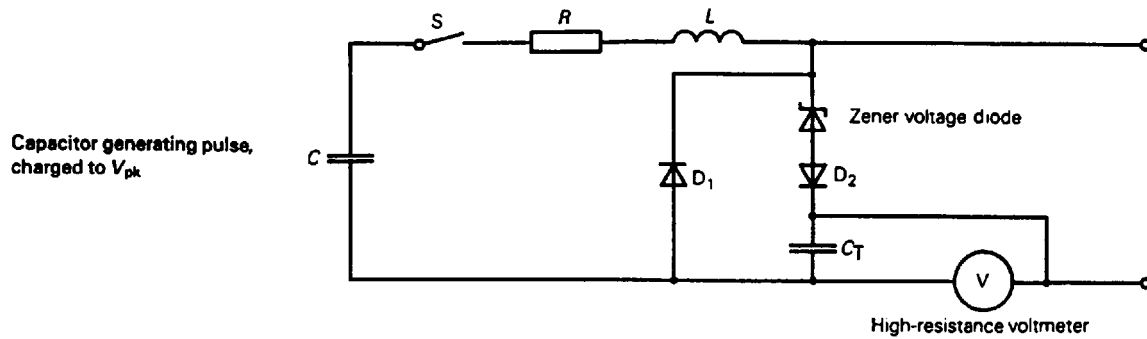

IEC 590/2000

**Components**

- R** resistance of the circuit (for the discussion on its value, see annex G)
  - L** inductance representing the self-inductance of the circuit (it is thus not necessary to materialize it by a separate element in this measuring circuit)
  - Z** Zener diode whose voltage  $V_z$  will be chosen as near as possible to the maximum value voltage range ( $V_{max}$ )
  - C** capacitor initially charged to a voltage  $V_{pk}$  equal to eight times the design voltage of the inverter and intended to deliver an energy of 1 mJ into the diode Z.
- As indicated in annex G, the value of its capacity is given by

$$C (\mu F) \frac{125}{V_d \times V_{max}} \text{ or } \left( \frac{100}{(V_d)^2} \text{ if } V_{max} = 1,25 V_a \right)$$

$C_T$  integration capacitor chosen so that after discharge, the voltage  $V$  on it is equal to or less than 1 V.

As indicated in annex G, the minimal value of its capacity (corresponding to a voltage equal to 1 V) is given by

$$C_T (\mu F) \frac{1000}{V_{max}} \text{ or } \left( \frac{800}{V_d} = \text{if } V_{max} = 1,25 V_a \right)$$

This capacitor must be of a non-electrolytic type so that a voltage is not induced by the dielectric film before the initial charge.

- D1** reverse current by-pass diode, PIV rated 20 times design voltage, fast  $t$  on and  $t$  off 200 ns.
- D2** blocking diode for PSU<sub>2</sub>. Prevents output impedance of PSU<sub>2</sub>, loading voltage pulse source (PSU<sub>1</sub>). Shall be fast type (approximately 1  $\mu$ s turn-off) with voltage rating equal to twice the maximum pulse voltage.
- S** switch

**Figure G.1 – Circuit for measuring short-duration pulse energy**

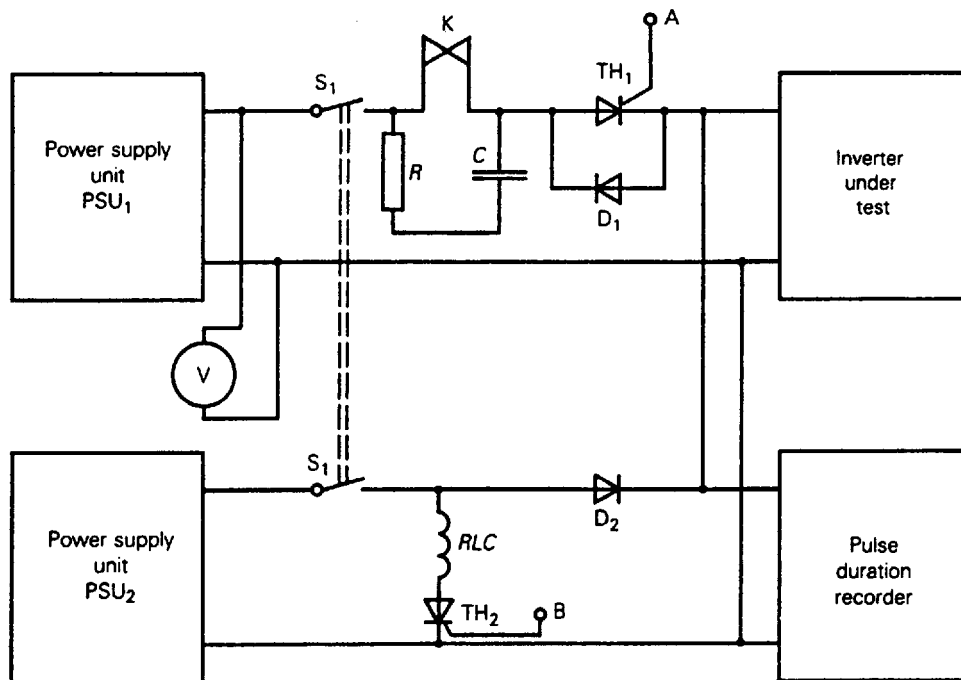

IEC 591/2000

**Components**

PSU<sub>1</sub> power supply unit, capable of supplying maximum pulse voltage required (maximum of voltage range + X design voltage) with pulse current demanded by inverter at this voltage with 2 % regulation (no load to full load).

PSU<sub>2</sub> power supply unit adjusted to maximum of input voltage range.

NOTE 1 Preferably both PSUs should be fitted with current limits to prevent damage in the event of the inverter under test breaking down.

TH<sub>1</sub> main switching thyristor used to apply voltage pulse to the inverter. Many common thyristors should be suitable for this job. They shall have a turn-on time of about 1 μs and adequate pulse current capability.

TH<sub>2</sub> thyristor controlling the action of the relay RLC.

D<sub>1</sub> reverse current by-pass diode for TH<sub>1</sub>. Allows initial oscillatory transients to operate. Shall be fast type (200 ns to 500 ns) with voltage rating equal to twice the maximum pulse voltage.

D<sub>2</sub> blocking diode for PSU<sub>2</sub>. Prevents output impedance of PSU<sub>2</sub>, loading voltage pulse source (PSU<sub>1</sub>). Shall be fast type (approximately 1 μs turn off) with voltage rating equal to twice the maximum pulse voltage.

RLC pulse termination relay with contacts K.

R and C spark suppression components.

Suggested values are 100 Ω and 0,1 μF (for 26 V inverters).

S<sub>1</sub> switch used as ON/OFF or reset control.

NOTE 2 The delay system for securing the correct duration of the pulse is not represented on the figure. It shall ensure the triggering of thyristor TH<sub>2</sub> 500 ms after the action of TH<sub>1</sub>, account being taken of the operating time of the relay.

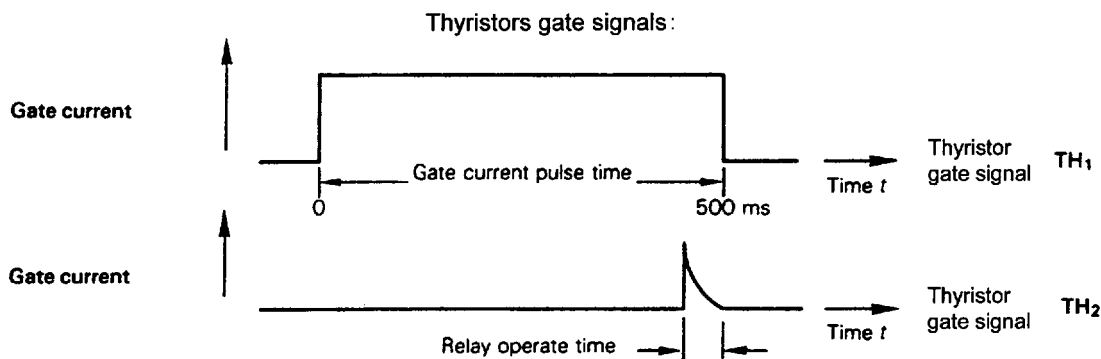

IEC 592/2000

**Figure G.2 – Suitable circuit for producing and applying long-duration pulses**

## Annex H (normative)

### Tests

#### H.1 Ambient temperature and test room

**H.1.1** Measurements shall be made in a draught-free room and at an ambient temperature within the range of 20 °C to 27 °C.

For those tests which require constant lamp performance, the ambient temperature around the lamp shall be within the range of 23 °C to 27 °C and shall not vary by more than 1 °C during the test.

**H.1.2** Apart from the ambient temperature, air circulation also influences the temperature of the lamp controlgear. For reliable results, the test room shall be free from draughts.

**H.1.3** Before measuring the resistance of a winding in the cold state, the lamp controlgear shall be left in the test room for a sufficient time prior to the test to ensure that it reaches the ambient temperature of the test room.

There may be differences in the ambient temperatures before and after heating of the lamp controlgear. This is difficult to correct because the temperature of the lamp controlgear will lag behind the changed ambient temperature. An additional lamp controlgear of the type to be tested shall be installed in the test room and its cold resistance measured at the beginning and end of the temperature test. The difference in resistance can be used as a basis for correcting the readings of the lamp controlgear under test, using the equation for determining the temperature.

The above difficulties can be eliminated by carrying out the measurements in a temperature-stabilized room, for which no corrections are necessary.

#### H.2 Supply voltage and frequency

##### H.2.1 Test voltage and frequency

Unless otherwise specified, the controlgear to be tested shall be operated at its design voltage and the reference ballast at its rated voltage and frequency.

##### H.2.2 Stability of supply and frequency

Unless otherwise specified, the supply voltage, and, where appropriate for the reference ballasts, the frequency shall be maintained constant within  $\pm 0,5$  %. However, during the actual measurement, the voltage shall be adjusted to within  $\pm 0,2$  % of the specified testing value.

##### H.2.3 Supply voltage waveform for reference ballast only

The total harmonic content of the supply voltage shall not exceed 3 %, harmonic content being defined as the root-mean-square (r.m.s.) summation of the individual components using the fundamental as 100 %.

### H.3 Electrical characteristics of lamps

The ambient temperature may affect the electrical characteristics of lamps (see H.1). In addition, lamps show an initial spread of characteristics independent of the ambient temperature; furthermore, such characteristics may change during the lamp's life.

For measurement of lamp controlgear temperatures at 100 % and 110 % of rated supply voltage, it is sometimes possible (for example, for chokes used in starter-operated circuits), to eliminate the influence of the lamp by operating the lamp controlgear at a short-circuit current equal to the value obtained with a reference lamp at 100 % or 110 % of rated voltage. The lamp is short-circuited and the supply voltage adjusted so that the required current passes through the circuit.

In case of doubt, the measurement shall be made with a lamp. These lamps shall be selected in the same manner as reference lamps, but disregarding the narrow tolerances on lamp voltage and wattage as required for reference lamps.

When assigning the temperature rise of lamp controlgear, the current flowing through the winding being measured shall be recorded.

### H.4 Magnetic effects

Unless otherwise specified, no magnetic object shall be allowed within 25 mm of any face of the reference ballast or the lamp controlgear under test.

### H.5 Mounting and connection of reference lamps

In order to ensure that the reference lamps repeat their electrical values with the greatest consistency, it is recommended that the lamps be mounted horizontally and be allowed to remain permanently in their test lampholders. As far as identification of lamp controlgear terminals will permit, reference lamps should be connected in circuit maintaining the polarity of the connections used during ageing.

### H.6 Reference lamp stability

**H.6.1** A lamp shall be brought to a condition of stable operation before carrying out measurements. No swirling shall be present.

**H.6.2** The characteristics of a lamp shall be checked immediately before and after each series of tests.

### H.7 Instrument characteristics

#### H.7.1 Potential circuits

Potential circuits of instruments connected across the lamp shall not pass more than 3 % of the nominal running current.

#### H.7.2 Current circuits

Current circuits of instruments connected in series with the lamp shall have a sufficiently low impedance such that the voltage drop shall not exceed 2 % of the objective lamp voltage. Where measuring instruments are inserted into parallel heating circuits, the total impedance of the instruments shall not exceed 0,5  $\Omega$ .

### H.7.3 RMS measurements

Instruments shall be essentially free from errors due to waveform distortion and shall be suitable for the operating frequencies. Care shall be taken to ensure that the earth capacitance of instruments does not disturb the operation of the unit under test. It may be necessary to ensure that the measuring point of the circuit under test is at earth potential.

### H.8 Inverter power sources

Where lamp controlgear are intended for use from battery supplies, it is permissible to substitute a d.c. power source other than a battery, provided that the source impedance is equivalent to that of a battery.

**NOTE** A non-inductive capacitor of appropriate rated voltage and with a capacitance of at least 50  $\mu\text{F}$ , connected across the supply terminals of the units under test normally provides a source impedance simulating that of a battery.

### H.9 Reference ballast

When measured in accordance with the requirements given in IEC 60921, reference ballasts shall have those characteristics specified both in that standard and on the appropriate lamp data sheets in IEC 60081 and IEC 60901.

### H.10 Reference lamps

Reference lamps shall be measured and selected as outlined in IEC 60921 and have the characteristics specified on the appropriate lamp data sheet in IEC 60081 and IEC 60901.

### H.11 Test conditions

#### H.11.1 Resistance measurement delays

Since the lamp controlgear may cool rapidly after switch-off, a minimum delay is recommended between switch-off and measurement of resistance. It is therefore recommended that the coil resistance be determined as a function of the elapsed time, from which the resistance at the moment of switch-off can be established.

#### H.11.2 Electrical resistance of contacts and leads

Connections shall be eliminated from the circuit wherever possible. If switches are used to switch from operating to test conditions, a regular check shall be made to verify that contact resistances in the switches remain sufficiently low not to affect the test results. Due account shall also be taken of the resistance of any connecting leads between the lamp controlgear and the resistance measuring instruments.

To ensure an improvement in measuring accuracy, it is recommended to apply the so-called four-point measurement with double wiring.

## H.12 Lamp controlgear heating

### H.12.1 Built-in lamp controlgear

#### H.12.1.1 Temperatures of lamp controlgear parts

The lamp controlgear shall be placed in an oven as detailed in clause 13 for the thermal endurance test of windings.

The lamp controlgear shall function electrically in a manner similar to that in normal use at rated supply voltage, as detailed in H.12.4.

The oven thermostats are then regulated in such a way that the internal temperature of the oven attains a value such that the temperature of the hottest winding is approximately equal to the claimed value of  $t_w$ .

After 4 h, the actual temperature of the winding is determined by the "change-in-resistance" method (see clause 13, equation (1)) and, if the difference with the value  $t_w$  is more than  $\pm 5$  K, the oven thermostats are readjusted to approximate as closely as possible the  $t_w$  temperature.

After thermal stability has been obtained, winding temperatures are measured, if possible by the "change-in-resistance" method (see clause 13, equation (1)) and, in other cases, by means of a thermocouple or the like.

The temperatures of lamp controlgear parts corrected for the difference between  $t_w$  and the measured winding temperature shall comply with clause 13.

#### H.12.1.2 Temperature of lamp controlgear windings

For lamp controlgear for which a temperature rise of the windings under normal conditions is claimed, the test arrangement is as follows:

*The lamp controlgear shall be placed in a draught-proof enclosure as detailed in annex F, the lamp controlgear being supported by two wooden blocks as shown in figure H.1.*

*The wooden blocks shall be 75 mm high, 10 mm thick and of a width equal to, or greater than, the width of the lamp controlgear. Furthermore, the blocks shall be positioned with the extreme end of the lamp controlgear aligned with the outer vertical sides of the block.*

*Where the lamp controlgear consists of more than one unit, each unit may be tested on separate blocks. Capacitors, unless enclosed with the lamp controlgear case, shall not be placed in the draught-proof enclosure.*

*The lamp controlgear shall be tested under normal conditions at rated supply voltage and frequency until steady temperatures are obtained.*

*Winding temperatures are measured, if possible by the "change-in-resistance" method (see clause 13, equation (1)).*



### H.12.2 Independent lamp controlgear

*The lamp controlgear shall be placed in a draught-proof enclosure as detailed in annex F, the lamp controlgear being mounted in a test corner consisting of three dull-black painted boards 15 mm to 20 mm thick and arranged so as to imitate two walls and the ceiling of a room. The lamp controlgear is secured to the ceiling of the test corner as close as possible to the walls, the ceiling extending at least 250 mm beyond the other sides of the lamp controlgear.*

*Other test conditions are the same as specified for luminaires in IEC 60598-1.*

### H.12.3 Integral lamp controlgear

*Integral lamp controlgear are not separately tested for limitation of lamp controlgear heating because they are tested as part of the luminaire in accordance with IEC 60598-1.*

### H.12.4 Test conditions

For the test under normal conditions, where lamp controlgear are operated with appropriate lamps, these shall be placed in such a way that the heat generated does not contribute to the heating of the lamp controlgear.

Lamps to be used for the limitation of lamp controlgear heating tests shall be deemed to be appropriate if, when associated with a reference ballast and operating in an ambient temperature of 25 °C, the lamp's running current does not deviate by more than 2,5 % from the corresponding objective values given in the relevant IEC lamp standard, or declared by the manufacturer for those lamps not yet standardized.

NOTE It is permitted, at the manufacturer's discretion, for reactor type lamp controlgear (simple choke impedance in series with the lamp), that the test and measurement be made without a lamp provided that the current is adjusted to the same value as found with the lamp at rated supply voltage.

With a non-reactor type lamp controlgear, it is necessary to ensure that representative losses are obtained.

*For starterless lamp controlgear with transformer parallel cathode heating, and where IEC 60081 and IEC 60901 show that lamps of the same rating are available with either low or high resistance cathodes, the tests shall be carried out using lamps having low resistance cathodes.*

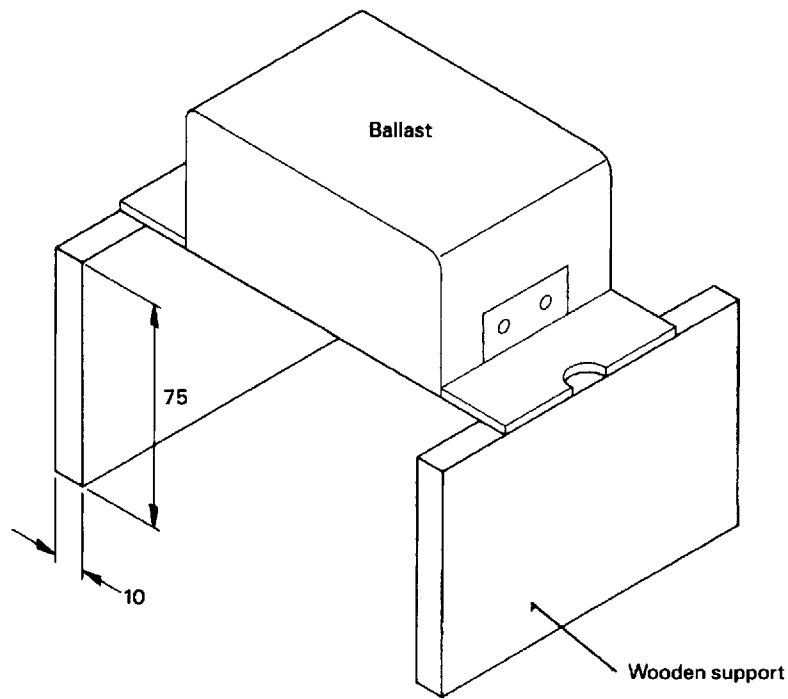

IEC 593/2000

(±1,0 mm tolerance on dimensions)

Dimensions in millimetres

Figure H.1 – Test arrangement for heating test

## Bibliography

- [1] IEC 60155, *Glow-starters for fluorescent lamps*
- [2] IEC 60216 (all parts), *Guide for the determination of thermal endurance properties of electrical insulating materials*
- [3] IEC 60479 (all parts), *Effects of current on human beings and livestock*
- [4] IEC 60598 (all parts), *Luminaires*
- [5] IEC 60664-1, *Insulation coordination for equipment within low-voltage systems – Part 1: Principles, requirements and tests*
- [6] IEC 60664-3, *Insulation coordination for equipment within low-voltage systems – Part 3: Use of coatings to achieve insulation coordination of printed board assemblies*
- [7] IEC 60925, *DC supplied electronic ballasts for tubular fluorescent lamps – Performance requirements*
- [8] IEC 60927, *Auxiliaries for lamps – Starting devices (other than glow starters) – Performance requirements*
- [9] IEC 61047, *DC or a.c. supplied electronic step-down convertors for filament lamps – Performance requirements*
- [10] IEC 61347-2-1, *Lamp controlgear – Part 2-1: Particular requirements for starting devices (other than glow starters)*
- [11] IEEE 101:1987, *IEEE Guide for the Statistical Analysis of Thermal Life Test Data*

## Annex ZA (normative)

### Normative references to international publications with their corresponding European publications

This European Standard incorporates by dated or undated reference, provisions from other publications. These normative references are cited at the appropriate places in the text and the publications are listed hereafter. For dated references, subsequent amendments to or revisions of any of these publications apply to this European Standard only when incorporated in it by amendment or revision. For undated references the latest edition of the publication referred to applies (including amendments).

NOTE When an international publication has been modified by common modifications, indicated by (mod), the relevant EN/HD applies.

<u>Publication</u>	<u>Year</u>	<u>Title</u>	<u>EN/HD</u>	<u>Year</u>
IEC 60065 (mod)	<sup>1)</sup>	Audio, video and similar electronic apparatus - Safety requirements	EN 60065 + corr. June	1998 <sup>2)</sup> 1999
IEC 60081	<sup>1)</sup>	Double-capped fluorescent lamps - Performance specifications	EN 60081	1998 <sup>2)</sup>
IEC 60112	<sup>1)</sup>	Method for determining the comparative and the proof tracking indices of solid insulating materials under moist conditions	HD 214 S2	1980 <sup>2)</sup>
IEC 60249	Series	Base materials for printed circuits	EN 60249	Series
IEC 60249-1	<sup>1)</sup>	Base materials for printed circuits Part 1: Test methods	EN 60249-1	1993 <sup>2)</sup>
IEC 60317-0-1	<sup>1)</sup>	Specifications for particular types of winding wires Part 0-1: General requirements - Enamelled round copper wire	EN 60317-0-1	1994 <sup>2)</sup>
IEC 60417	Series	Graphical symbols for use on equipment	EN 60417	Series
IEC 60529	<sup>1)</sup>	Degrees of protection provided by enclosures (IP Code)	EN 60529 + corr. May	1991 <sup>2)</sup> 1993
IEC 60598-1 (mod)	<sup>1)</sup>	Luminaires Part 1: General requirements and tests	EN 60598-1 + A11	2000 <sup>2)</sup> 2000
IEC 60691	<sup>1)</sup>	Thermal-links - Requirements and application guide	EN 60691	1995 <sup>2)</sup>
IEC 60695-2-1/0	<sup>1)</sup>	Fire hazard testing Part 2: Test methods -- Section 1/sheet 0: Glow-wire test methods - General	EN 60695-2-1/0	1996 <sup>2)</sup>

<sup>1)</sup> undated reference.

<sup>2)</sup> valid edition at date of issue.

<u>Publication</u>	<u>Year</u>	<u>Title</u>	<u>EN/HD</u>	<u>Year</u>
IEC 60695-2-2	1)	Part 2: Test methods -- Section 2: Needle-flame test	EN 60695-2-2	1994 <sup>2)</sup>
IEC 60730-2-3 (mod)	1)	Automatic electrical controls for household and similar use Part 2-3: Particular requirements for thermal protectors for ballasts for tubular fluorescent lamps	EN 60730-2-3	1992 <sup>2)</sup>
IEC 60901	1)	Single-capped fluorescent lamps - Performance specifications	EN 60901	1996 <sup>2)</sup>
IEC 60921 (mod)	1)	Ballasts for tubular fluorescent lamps - Performance requirements	EN 60921	1991 <sup>2)</sup>
IEC 60923	1)	Auxiliaries for lamps - Ballasts for discharge lamps (excluding tubular fluorescent lamps) - Performance requirements	EN 60923	1996 <sup>2)</sup>
IEC 60929	1)	A.C. supplied electronic ballasts for tubular fluorescent lamps - Performance requirements	EN 60929	1992 <sup>2)</sup>
IEC 60990	1)	Methods of measurement of touch current and protective conductor current	EN 60990	1999 <sup>2)</sup>
IEC 61347-2-2	1)	Lamp controlgear Part 2-2: Particular requirements for d.c. or a.c. supplied electronic step-down convertors for filament lamps	EN 61347-2-2	2001 <sup>2)</sup>
IEC 61347-2-8	1)	Part 2-8: Particular requirements for ballasts for fluorescent lamps	EN 61347-2-8	2001 <sup>2)</sup>
IEC 61347-2-9	1)	Part 2-9: Particular requirements for ballasts for discharge lamps (excluding fluorescent lamps)	EN 61347-2-9	2001 <sup>2)</sup>
ISO 4046	1)	Paper, board, pulp and related terms - Vocabulary	-	-

**BS EN**  
**61347-1:2001**  
**IEC**  
**61347-1:2000**

---

## **BSI — British Standards Institution**

BSI is the independent national body responsible for preparing British Standards. It presents the UK view on standards in Europe and at the international level. It is incorporated by Royal Charter.

### **Revisions**

British Standards are updated by amendment or revision. Users of British Standards should make sure that they possess the latest amendments or editions.

It is the constant aim of BSI to improve the quality of our products and services. We would be grateful if anyone finding an inaccuracy or ambiguity while using this British Standard would inform the Secretary of the technical committee responsible, the identity of which can be found on the inside front cover. Tel: 020 8996 9000. Fax: 020 8996 7400.

BSI offers members an individual updating service called PLUS which ensures that subscribers automatically receive the latest editions of standards.

### **Buying standards**

Orders for all BSI, international and foreign standards publications should be addressed to Customer Services. Tel: 020 8996 9001. Fax: 020 8996 7001. Standards are also available from the BSI website at <http://www.bsi-global.com>.

In response to orders for international standards, it is BSI policy to supply the BSI implementation of those that have been published as British Standards, unless otherwise requested.

### **Information on standards**

BSI provides a wide range of information on national, European and international standards through its Library and its Technical Help to Exporters Service. Various BSI electronic information services are also available which give details on all its products and services. Contact the Information Centre. Tel: 020 8996 7111. Fax: 020 8996 7048.

Subscribing members of BSI are kept up to date with standards developments and receive substantial discounts on the purchase price of standards. For details of these and other benefits contact Membership Administration. Tel: 020 8996 7002. Fax: 020 8996 7001. Further information about BSI is available on the BSI website at <http://www.bsi-global.com>.

### **Copyright**

Copyright subsists in all BSI publications. BSI also holds the copyright, in the UK, of the publications of the international standardization bodies. Except as permitted under the Copyright, Designs and Patents Act 1988 no extract may be reproduced, stored in a retrieval system or transmitted in any form or by any means – electronic, photocopying, recording or otherwise – without prior written permission from BSI.

This does not preclude the free use, in the course of implementing the standard, of necessary details such as symbols, and size, type or grade designations. If these details are to be used for any other purpose than implementation then the prior written permission of BSI must be obtained.

If permission is granted, the terms may include royalty payments or a licensing agreement. Details and advice can be obtained from the Copyright Manager. Tel: 020 8996 7070.

BSI  
 389 Chiswick High Road  
 London  
 W4 4AL