

Top Victory Electronics	Spec Standard	Part No : 80LL17T-2-T G
-------------------------	---------------	-------------------------

- 2.8 PIN 4&12 CUT OFF. PIN 2 CUT OFF AFTER SOLDER.
 2.9 THE TRANSFORMER IS A LEAD-FREE SOLDER CORRESPONDENCE PRODUCT

3、CONDITION OF WORK

- 3.1 THE PART NORMAL WORK BE ALLOWED AMBIENT TEMPERATURE : -25 ~ +85 .
 3.2 THE PART MUST BE ALLOWED HIGH TEMPERATURE: +125 .
 3.3 THE PART NORMAL WORK BE ALLOWED TEMPERATURE-DEPENDENT: 40
 3.4 AMBIENT TEMPERATURE OF THE PART BE ALLOWED STORAGE: -25 ~ +85
 3.5 THE PART BE ALLOWED WORK AMBIENT FREQUENCY: 1Hz ~ 95KHz
 3.6 STORAGE:(1)STORGE CONDITION:TEMPERATURE:-10 ~40 ,UMI DITY: <80%
 (2)STORGE PERIOD:THE PRODUCTS WHICH STORAGE IN TPV OVER 6 MONTHS AGOOR PRODUCED IN TDK OVER 12MONTHS SHOULD BE EXAMINED AND USED.

4、SCHEMATIC & WINDING CONSTRUCTION

4.1 SCHEMATIC

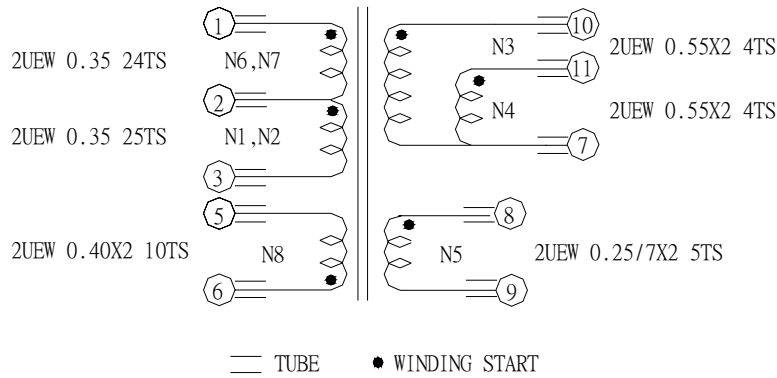

4.2 WINDING CONSTRUCTION

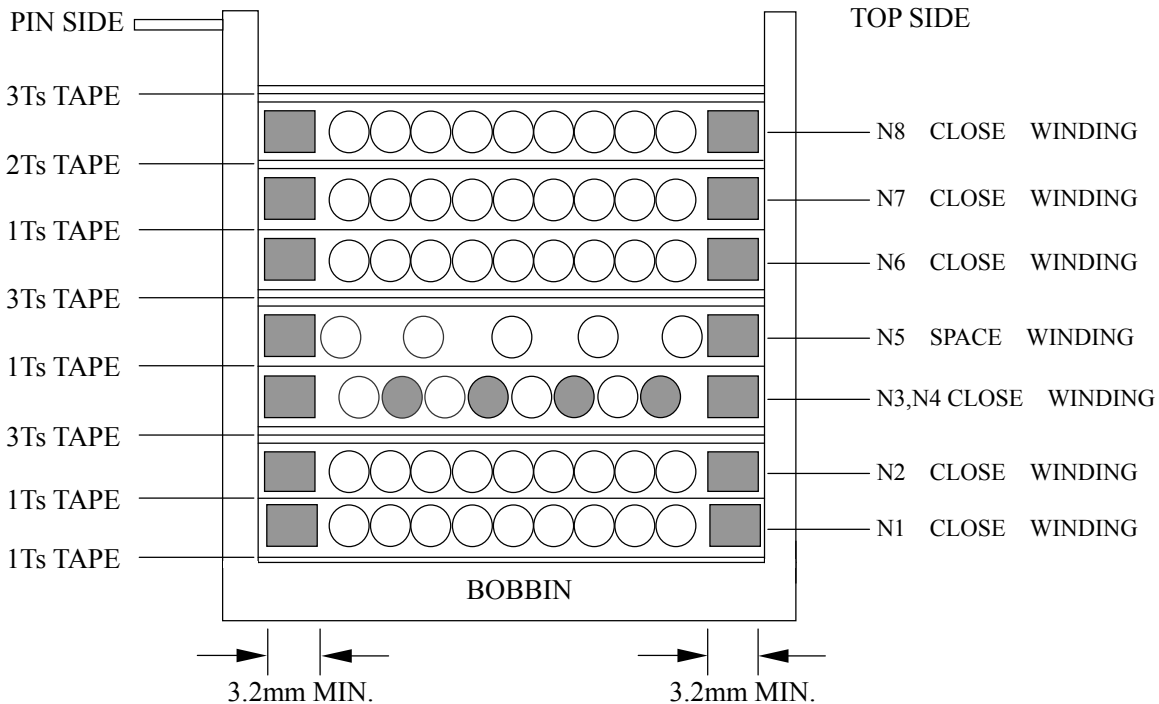

4.3 WINDING MODE:

WINDING	S	F	WIRE	TURNS	TAPE	LAYER	BOTTOM MARGIN	TOP TAPE
					1			
N1	2	3	0.35X1	25Ts	1	1	3.2	3.2
N2	2	3	0.35X1	25Ts	3	1	3.2	3.2
N3	10	7	0.55X2	4Ts			3.2	3.2
N4	11	7	0.55X2	4Ts	1	1		
N5	8	9	0.25/7X2	5Ts	3	1	3.2	3.2
N6	1	2	0.35X1	24Ts	1	1	3.2	3.2
N7	1	2	0.35X1	24Ts	2	1	3.2	3.2
N8	6	5	0.40X2	10Ts	3	1	3.2	3.2

4.4 WINDING DIRECTION: IT IS CLOCKWISE FROM PIN1-6 SIDE.

5、 ELECTRIC CHARACTERISTICS

5.1 INDUCTANCE :

L (1 -3)=700.0 μ H \pm 5 % @ 10 KHz,1 Vrms, 25 °C

L (1 -3)=698.4 μ H \pm 5 % @ 40 KHz,1 Vrms, 25 °C

L (1 -3)=703.1 μ H \pm 5 % @ 100KHz,1 Vrms, 25 °C

5.2 BIAS:

L (1 -3)1.0A=L(0A)x90%MIN @ 10 KHz,1 Vrms , 25 or100

5.3 LEAKAGE INDUCTANCE :

Le (1 -3)=12.0uH MAX @10 KHz,1 Vrms , 25°C .

SECONDARY WINDING SHORTED.

5.4 VOLTAGE:

V (6 -5)=207 mV \pm 5 % V (10-7)=82 mV \pm 5 %

V (11-7)=82 mV \pm 5 % V (8 -9)=103 mV \pm 5 %

APPLY 20 KHz, 1 Vrms, 25°C BETWEEN PRIMARY WINDING (1 -3) .

5.5 DC RESISTANCE:

R(1 -3)=290 mOHM MAX R(6 -5)=70 mOHM MAX

R(10-7)=18 mOHM MAX R(11 -7)=18 mOHM MAX

R(8 -9)=16 mOHM MAX

6、 INSULATION CHARACTERISTICS :

6.1 HI-POT TEST:

P—S: AC 3750 V, 50/60 Hz, 1 mA , 1 Minute.

P,S—CORE: AC 1875 V, 50/60 Hz, 1 mA , 1 Minute.

P—P: AC 1875 V, 50/60 Hz, 1 mA , 1 Minute.

6.2 INSULATION RESISTANCE:

P—S: DC 500 V, 100 M Ω MIN

P,S—CORE: DC 500 V, 100 M Ω MIN

P—P: DC 500 V, 100 M Ω MIN

6.3 LAYER SHORT TEST:

APPLY A VOLTAGE OF 1.0 KVp-p AC BETWEEN THE PRIMARY WINDING (1 -3)

WITHOUT DAMAGE AS ARKING ,ETC.