

UL 60335-1

ISBN 0-7629-0541-7

**Safety of Household and
Similar Electrical Appliances,
Part 1: General Requirements**

Underwriters Laboratories Inc. (UL)
333 Pfingsten Road
Northbrook, IL 60062-2096

UL Standard for Safety
for
Safety of Household and Similar Electrical Appliances, Part 1: General Requirements, UL 60335-1

Second Edition, Dated March 2, 2000

The master for this Standard at UL's Northbrook Office is the official document insofar as it relates to a UL service and the compliance of a product with respect to the requirements for that product and service, or if there are questions regarding the accuracy of this Standard.

UL's Standards for Safety are copyrighted by UL. Neither a printed copy of a Standard, nor the distribution diskette for a Standard-on-Diskette and the file for the Standard on the distribution diskette should be altered in any way. All of UL's Standards and all copyrights, ownerships, and rights regarding those Standards shall remain the sole and exclusive property of UL.

All rights reserved. No part of this publication may be reproduced, stored in a retrieval system, or transmitted in any form by any means, electronic, mechanical photocopying, recording, or otherwise without prior permission of UL.

Revisions of UL Standards for Safety are issued from time to time. A UL Standard for Safety is current only if it incorporates the most recently adopted revisions.

UL provides this Standard "as is" without warranty of any kind, either expressed or implied, including but not limited to, the implied warranties of merchantability or fitness for any purpose.

In no event will UL be liable for any special, incidental, consequential, indirect or similar damages, including loss of profits, lost savings, loss of data, or any other damages arising out of the use of or the inability to use this Standard, even if UL or an authorized UL representative has been advised of the possibility of such damage. In no event shall UL's liability for any damage ever exceed the price paid for this Standard, regardless of the form of the claim.

UL will attempt to answer support requests concerning WordPerfect, Envoy, and Standards-on-Diskette. However, this support service is offered on a reasonable efforts basis only, and UL may not be able to resolve every support request. UL supports a Standards-on-Diskette only if it is used under the conditions and operating systems for which it is intended. UL's support policies may change from time-to-time without notification.

UL reserves the right to change the format, presentation, file types and formats, delivery methods and formats, and the like of both its printed and electronic Standards without prior notice.

Standards-on-Diskette purchasers agree to defend, indemnify, and hold UL harmless from and against any loss, expense, liability, damage, claim, or judgement (including reasonable attorney's fees) resulting from any error or deviation introduced while purchaser is storing a Standard-on-Diskette on the purchaser's computer system.

If a single-user version Standards-on-Diskette was purchased, one copy of this Standard may be stored on the hard disk of a single personal computer, or on a single LAN file-server or the permanent storage device of a multiple-user computer in such a manner that this Standard may only be accessed by one user at a time and for which there is no possibility of multiple concurrent access. The original distribution diskette should be stored in a safe place.

If a multiple-user version Standards-on-Diskette was purchased, one copy of the Standard may be stored on a single LAN file-server, or on the permanent storage device of a multiple-user computer. The number of concurrent users shall not exceed the number of users authorized for the Standards-on-Diskette version. The original distribution diskette should be stored in a safe place.

Standards-on-Diskette are intended for on-line use, such as for viewing the requirements of a Standard, conducting a word search, and the like. Only one copy of the Standard may be printed from each single-user version of a Standards-on-Diskette. Only one copy of the Standard may be printed for each authorized user of a multiple-user version of a Standards-on-Diskette. An employee of an organization purchasing a Standard-on-Diskette can make a copy of the page or pages being viewed for their own fair and/or practical internal use. Because of differences in the computer/software/printer setup used by UL and those of Standards-on-Diskette purchasers, the printed copy obtained by a purchaser may not look exactly like the on-line screen view or the printed Standard.

The requirements in this Standard are now in effect, except for those paragraphs, sections, tables, figures, and/or other elements of the Standard having future effective dates as indicated in the note following the affected item. The prior text for requirements that have been revised and that have a future effective date are located after the Standard, and are preceded by a "SUPERSEDED REQUIREMENTS" notice.

New product submittals made prior to a specified future effective date will be judged under all of the requirements in this Standard including those requirements with a specified future effective date, unless the applicant specifically requests that the product be judged under the current requirements. However, if the applicant elects this option, it should be noted that compliance with all the requirements in this Standard will be required as a condition of continued Listing, Recognition, and Follow-Up Services after the effective date, and understanding of this should be signified in writing.

Copyright 2000 Underwriters Laboratories Inc.

MARCH 2, 2000

1

UL 60335-1

Standard for

**Safety of Household and Similar Electrical Appliances,
Part 1: General Requirements**

First Edition – November, 1998

Second Edition

March 2, 2000

An effective date included as a note immediately following certain requirements is one established by Underwriters Laboratories Inc.

Revisions of this standard will be made by issuing revised or additional pages bearing their date of issue. A UL Standard is current only if it incorporates the most recently adopted revisions, all of which are itemized on the transmittal notice that accompanies the latest set of revised requirements.

ISBN 0-7629-0482-8

COPYRIGHT 1998, 2000 UNDERWRITERS LABORATORIES INC.

CONTENTS

| | |
|----------------------|---|
| Preface (UL) | 3 |
| Foreword (UL) | 4 |
| Foreword (IEC) | 6 |

INTRODUCTION

| | |
|--|-----|
| 1 Scope | 15 |
| 2 Definitions | 16 |
| 3 General requirement | 23 |
| 4 General conditions for the tests | 23 |
| 5 Void | 27 |
| 6 Classification | 27 |
| 7 Marking and instructions | 27 |
| 8 Protection against access to LIVE PARTS | 35 |
| 9 Starting of motor-operated appliances | 39 |
| 10 Power input and current | 39 |
| 11 Heating | 41 |
| 12 Void | 49 |
| 13 Leakage current and electric strength at operating temperature | 49 |
| 14 Void | 52 |
| 15 Moisture resistance | 52 |
| 16 Leakage current and electric strength | 54 |
| 17 Overload protection of transformers and associated circuits | 58 |
| 18 Endurance | 58 |
| 19 Abnormal operation | 58 |
| 20 Stability and mechanical hazards | 66 |
| 21 Mechanical strength | 67 |
| 22 Construction | 68 |
| 23 Internal wiring | 79 |
| 24 Components | 81 |
| 25 Supply connection and external flexible cords | 84 |
| 26 Terminals for external conductors | 94 |
| 27 Provision for earthing | 98 |
| 28 Screws and connections | 107 |
| 29 CREEPAGE DISTANCES, CLEARANCES and distances through insulation | 110 |
| 30 Resistance to heat, fire and tracking | 116 |
| 31 Resistance to rusting | 120 |
| 32 Radiation, toxicity, and similar hazards | 120 |

| | |
|---|-----|
| Figures | 121 |
| Annex A – Normative References | 136 |
| Annex B – Appliances Powered by Rechargeable Batteries | 139 |
| Annex C – Ageing Test on Motors | 142 |
| Annex D – Alternative Requirements for Protected Motor Units | 144 |
| Annex E – Measurement of Creepage Distances and Clearances | 145 |
| Annex F – Motors Not Isolated from the Supply Mains | 152 |
| Annex G – Circuit for Measuring Leakage Currents | 155 |
| Annex H – Selection and Sequence of the Tests of Clause 30 | 157 |
| Annex J – Burning Test | 158 |
| Annex K – Glow – Wire Test | 159 |
| Annex L – Bad – Connection Test With Heaters | 160 |
| Annex M – Needle – Flame Test | 162 |
| Annex N – Proof Tracking Test | 163 |
| Annex P – Severity of Duty Conditions of Insulating Material | 164 |
| Annex Q – Capacitors | 166 |
| Annex R – Safety Isolating Transformers | 168 |
| Annex S – Switches | 169 |
| Annex DVA – Glossary of Equivalent Terms | 170 |
| Annex DVB – Terminology | 171 |
| Annex DVC – UL Component Requirements | 172 |
| Annex DVD – US Regulatory Requirements | 177 |
| Annex DVE – UL Leakage Current Requirements | 189 |

Preface (UL)

This UL Standard is based on IEC Publication 60335-1: third edition Safety of Household and Similar Appliances, part 1: General Requirements as revised by Amendments 1 and 2. IEC publication 60335-1 is copyrighted by the IEC.

This is the UL Standard for Safety of Household and Similar Electrical Appliances, Part 1: General Requirements. This UL part 1 is to be used in conjunction with the appropriate UL part 2, which contains clauses to supplement or modify the corresponding clauses in part 1, to provide the relevant requirements for each type of product.

The text, figures and tables of IEC publication 60335-1, Safety of Household and Similar Appliances, part 1: General Requirements copyright 1991 as amended November 1994 are used in this Standard with the consent of the IEC and the American National Standards Institute (ANSI). The IEC copyrighted material has been reproduced with permission from ANSI. ANSI should be contacted regarding the reproduction of any portion of the IEC material. The IEC Foreword and Introduction are not a part of the requirements of this Standard but are included for information purposes only.

Copies of IEC Publication 60335-1 may be purchased from ANSI, 11 West 42nd street, New York, New York, 10036, (212) 642-4900.

Note – Although the intended primary application of this Standard is stated in its Scope, it is important to note that it remains the responsibility of the users of the Standard to judge its suitability for their particular purpose.

FOREWORD

A. This Standard contains basic requirements for products covered by Underwriters Laboratories Inc. (UL) under its Follow-Up Service for this category within the limitations given below and in the Scope section of this Standard. These requirements are based upon sound engineering principles, research, records of tests and field experience, and an appreciation of the problems of manufacture, installation, and use derived from consultation with and information obtained from manufacturers, users, inspection authorities, and others having specialized experience. They are subject to revision as further experience and investigation may show is necessary or desirable.

B. The observance of the requirements of this Standard by a manufacturer is one of the conditions of the continued coverage of the manufacturer's product.

C. A product which complies with the text of this Standard will not necessarily be judged to comply with the Standard if, when examined and tested, it is found to have other features which impair the level of safety contemplated by these requirements.

D. A product employing materials or having forms of construction differing from those detailed in the requirements of this Standard may be examined and tested according to the intent of the requirements and, if found to be substantially equivalent, may be judged to comply with the Standard.

E. UL, in performing its functions in accordance with its objectives, does not assume or undertake to discharge any responsibility of the manufacturer or any other party. The opinions and findings of UL represent its professional judgment given with due consideration to the necessary limitations of practical operation and state of the art at the time the Standard is processed. UL shall not be responsible to anyone for the use of or reliance upon this Standard by anyone. UL shall not incur any obligation or liability for damages, including consequential damages, arising out of or in connection with the use, interpretation of or reliance upon this Standard.

F. Many tests required by the Standards of UL are inherently hazardous and adequate safeguards for personnel and property shall be employed in conducting such tests.

DEVIATIONS

GENERAL

Deviations from the text of International Electrotechnical Commission (IEC) publication 60335-1, Safety of Household and Similar Appliances, part 1: General Requirements copyright 1991 as amended November 1994 are indicated by notations (deviations) and are presented in bold text.

There are five types of deviations as noted below. The deviation type is noted on the first line of the deviation in the standard. The standard may not include all types of these deviations.

DR – These are deviations based on the National Electrical Code (NEC) and other U.S. Regulatory Requirements.

D1 – These are deviations which are based on basic safety principles and requirements, elimination of which compromise safety for U.S. consumers and users of products.

D2 – These are deviations based on safety practices. These are deviations for IEC requirements that may be acceptable, but adopting the IEC requirements would require considerable retesting or redesign on the manufacturer's part.

DC – These are deviations based on the component standards and will not be deleted until a particular component standard is harmonized with the IEC component standard.

DE – These are deviations based on editorial comments or corrections.

Annex DVA contains equivalent North American terms for some of the IEC terms used in this standard. Annex DVB contains appropriate replacement text for some of the IEC text used in this standard

INTERNATIONAL ELECTROTECHNICAL COMMISSION

SAFETY OF HOUSEHOLD AND SIMILAR ELECTRICAL APPLIANCES

Part 1: General requirements

FOREWORD

- 1) The IEC (International Electrotechnical Commission) is a worldwide organization for standardization comprising all national electrotechnical committees (IEC National Committees). The object of the IEC is to promote international cooperation on all questions concerning standardization in the electrical and electronic fields. To this end and in addition to other activities, the IEC publishes International Standards. Their preparation is entrusted to technical committees; any IEC National Committee interested in the subject dealt with may participate in this preparatory work. International, governmental and non-governmental organizations liaising with the IEC also participate in this preparation. The IEC collaborates closely with the International Organization for Standardization (ISO) in accordance with conditions determined by agreement between the two organizations.
- 2) The formal decisions or agreements of the IEC on technical matters, prepared by technical committees on which all the National Committees having a special interest therein are represented, express, as nearly as possible, an international consensus of opinion on the subjects dealt with.
- 3) They have the form of recommendations for international use published in the form of standards, technical reports or guides and they are accepted by the National Committees in that sense.
- 4) In order to promote international unification, IEC National Committees undertake to apply IEC International Standards transparently to the maximum extent possible in their national and regional standards. Any divergence between the IEC Standard and the corresponding national or regional standard shall be clearly indicated in the latter.
- 5) The IEC provides no marking procedure to indicate its approval and cannot be rendered responsible for any equipment declared to be in conformity with one of its Standards.

This standard has been prepared by IEC technical committee 61: Safety of household and similar electrical appliances.

The text of this standard is based on the following documents:

| DIS | Report on voting | | Amendment to DIS | Report on voting |
|-----------|------------------|--|------------------|------------------|
| 61(CO)612 | 616(CO)649 | | 61(CO)650 | 61(CO)667 |

Full information on the voting for the approval of this standard can be found in the voting reports indicated in the above table.

This second impression of IEC 60335-1 third edition incorporates many editorial corrections compared to the first impression (1991-04). However, they do not affect the technical content of this standard. Except the foreword, page, clause and subclause numbering is identical to the first impression.

This standard contains amendments No. 1 and No. 2 to IEC 60335-1.

These amendments have been prepared by IEC technical committee 61: Safety of household and similar electrical appliances.

The text of these amendments are based on the following documents:

| DIS | Report on voting |
|--------------|------------------|
| 61(CO)792 | 61/866/RVD |
| 61/1569/FDIS | 61/1623/RVD |

Full information on the voting for the approval of these amendments can be found in the reports on voting indicated in the above table.

Annex B contained in amendment No. 1 cancels and replaces IEC 335-2-18 (1984). IEC 335-2-19 (1984) et IEC 335-2-20 (1984).

References to IEC 817 (1984) has been replaced by reference to IEC 68-2-63 which is technically equivalent. Part 2's of IEC 335 which refer to the original impression of this third edition can be used with this second impression.

This part 1 is to be used in conjunction with the appropriate part 2, which contains clauses to supplement or modify the corresponding clauses in part 1, to provide the relevant requirements for each type of product.

Individuals countries may wish to consider its application, so far as is reasonable, to appliances not mentioned in part 2, and to appliances designed on new principles.

If the functions of an appliance are covered by different part 2's of IEC 335, the relevant part 2 is applied to each function separately, so far as is reasonable. If applicable, the influence of one function on the other is taken into account.

Normative references to other IEC and ISO standards are given in annex A.

All annexes are normative except annex H.

NOTE – The following print types are used:

- Requirements: in roman type
- *Test specifications: in italic type*
- **Notes: In small roman type.**
- Words in SMALL CAPITAL LETTERS in the text are defined in clause 2.

The following differences exist in some countries:

- 2: Steady conditions are defined (Poland).
- 2.5.2: The SAFETY EXTRA-LOW VOLTAGE shall not exceed 30 V (42,4 V peak) (U.S.A.).
- 3: The d.c. component in the appliance neutral is limited (Australia).
- 4.7: The ambient testing temperature is 25EC ± 10EC (China, Japan and U.S.A.).

- 4.14: Accessible metal parts that are not liable to become energized (such as a metal nameplate or decorative part on a plastic enclosure) do not need to be earthed. Accessible non-metallic parts need only provide BASIC INSULATION (U.S.A.).
- 6.1: CLASS 0 AND CLASS 0I APPLIANCES are not allowed (Australia, Austria, Czechoslovakia, Finland, France, Germany, Greece, Hungary, Israel, India, Ireland, Italy, Netherlands, New Zealand, Norway, Poland, Singapore, Sweden, Switzerland United Kingdom, Yugoslavia).
- 6.2: Protection against harmful ingress of water is determined by methods other than those given in IEC 529 (U.S.A.).
- 7.1: The IP number is not required to be marked (U.S.A.).
- 7.6: Some of these symbols are not used (U.S.A.).
- 7.8: Additional methods are permitted for identifying earthing terminals and terminals for neutral conductors (U.S.A.).
- 7.12.2: The 3 mm contact separation does not apply (Australia, Japan, New Zealand, U.S.A.).
- 7.14: Different tests are used (U.S.A.).
- 8.1.1: The test is not necessarily repeated with the 20 N force (U.S.A.).
- 8.1.1: Protection against contact with LIVE PARTS of the lamp cap is not required (U.S.A.).
- 8.1.2 and 8.1.3: The test pin and test probe are not used (U.S.A.).
- 8.1.5: BUILT-IN APPLIANCES, FIXED APPLIANCES and appliances delivered in separate units are not required to be protected by at least BASIC INSULATION before installation (U.S.A.).
- 9: The ability of a motor to start without blowing a quick-acting fuse is required (U.S.A.).
- 10.1 and 10.2: Positive limits of 5% for HEATING APPLIANCES and 10% for MOTOR-OPERATED APPLIANCES are required and in general there are no negative deviations (U.S.A.).
- 11.4, 11.5 and 11.6: HEATING APPLIANCES and heater circuits of COMBINED APPLIANCES are operated at RATED POWER INPUT or RATED VOLTAGE, whichever is the more severe; all other appliances and circuits are operated at RATED VOLTAGE (U.S.A.).
- 11.8, table 3: Temperature rise limits for certain materials are different (U.S.A.).
- 13.2: The test circuit and some leakage current limits are different (U.S.A., India).
- 13.3: The values of certain test voltages are different depending on the RATED VOLTAGE (U.S.A.).
- 13.3: A 500 VA test transformer is used (U.S.A.).

-
- 15.1.1 and 15.1.2: The IP system is not used and the tests are different (U.S.A.).
 - 15.3: The test is conducted with a relative humidity of $(88 \pm 2) \%$ at a temperature of $32\text{EC} \pm 2\text{EC}$ (U.S.A.).
 - 16.2: The test is conducted at nominal supply voltage and some of the leakage current values are different (U.S.A.).
 - 16.3: Some test voltages and methods are different (U.S.A.).
 - 19.1: The circuit protection device is permitted to provide necessary protection (U.S.A.).
 - 19.2 to 19.4: Generally the tests are conducted at nominal supply voltage or RATED POWER INPUT (U.S.A.).
 - 19.13: the temperature rise limits of table 7 are not applicable (U.S.A.).
 - 20.1: A stability test at 15 degrees is not conducted and an appliance tested in an overturned position is judged under abnormal test criteria (U.S.A.).
 - 21: Impact force is applied with a falling steel ball instead of the spring operated impact test apparatus (U.S.A.).
 - 22.1: The IP system is not used and tests are not the same as specified in IEC 529 (U.S.A.).
 - 22.2: The second paragraph of this subclause dealing with single-phase CLASS I APPLIANCES with heating elements cannot be complied with because of the supply system (France and Norway).
 - 22.2: Double-pole switches or PROTECTIVE DEVICES are required (Norway).
 - 22.2: Disconnection of the neutral is not necessary for all STATIONARY APPLIANCES (U.S.A.).
 - 22.2: The SUPPLY CORD is not required to be fitted with a plug (Ireland).
 - 22.6: This test is not conducted (U.S.A.).
 - 22.11: Different criteria for snap-on constructions are required (U.S.A.).
 - 22.12: Positive forms of securement are required (U.S.A.).
 - 22.14: Sharp edges are evaluated by means of a sharp edge testing device (U.S.A.).
 - 22.35 and 22.36: Metal parts are generally not required to be separated by DOUBLE OR REINFORCED INSULATION (U.S.A.).
 - 22.44: Appliances may be acceptable based on additional evaluation (U.S.A.).
 - 23.5: Requirements for insulated internal wiring are different (U.S.A.).
 - 23.7: Green wiring may be used instead of green/yellow wiring (New Zealand and U.S.A.).

- 23.7: The requirement only applies to wiring that is accessible when making supply connections (U.S.A.).
- 24.1.2: A different number of cycles is required and note 2 does not apply (U.S.A.).
- 24.1.3: The numbers of cycles is different and the note does not apply (U.S.A.).
- 24.3: The requirement for 3 mm contact separation does not apply (U.S.A.).
- 25.1: The SUPPLY CORD is not required to be fitted with a plug (Ireland).
- 25.3: A set of SUPPLY LEADS is not permitted (Norway, Sweden, Denmark, Finland, Netherlands).
- 25.3: The use of a set of terminals for connection of a flexible cord is not generally permitted (U.S.A.).
- 25.8: Conductor cross-sectional areas are different (Australia, New Zealand and U.S.A.).
- 25.8: 0,5 mm² SUPPLY CORDS are not allowed for CLASS I APPLIANCES (Australia and New Zealand).
- 25.10: green insulation is also permitted (U.S.A.).
- 25.14.2: No more than one separate insulation is required (U.S.A.).
- 25.16: Fully removable cord anchorages are allowable (New Zealand, Australia).
- 25.16: A pull of 35 lbs is applied except for small appliances and generally the torque test is not used (U.S.A.).
- 26.2: Cross-sectional areas are specified according to American Wire Gauge (AWG) (U.S.A.).
- 26.4 and 26.5: The tests only apply to terminals for connection to fixed wiring (U.S.A.).
- 27.2: The requirements for screwless terminals are different (U.S.A.).
- 27.6: The requirement does not apply (U.S.A.).
- 28.1: Generally, tests of this type are not required (U.S.A.).
- 29.1: Different CREEPAGE DISTANCES and CLEARANCES may be applicable (U.S.A.).
- 30.1: The minimum value for the ball-pressure test for parts retaining LIVE PARTS is 95EC or 40 K higher than the clause 11 temperature rise. For enclosures, the minimum value is 75EC or a mold-stress test is conducted at 10 K above the clause 11 temperature (U.S.A.).
- 30.2.1: An ignition test cannot be used to assure a slow burning rate (U.S.A.).
- 30.2.4: Printed circuits boards operated at mains voltage are required to be FV-0 or FV-1 or to meet the needle-flame test (Australia).

-
- B.7.12: Appliances having non-replaceable batteries shall be marked with an appropriate symbol when the batteries have a content of mercury or cadmium exceeding 0.025% by weight (Sweden and Switzerland).
 - B.21.101: The requirement is different (U.S.A.).
 - F.1.1: The annex applies to motors having a WORKING VOLTAGE not exceeding 30 V (U.S.A.).
 - B.7.12: Appliances having non - replaceable batteries shall be marked with an appropriate symbol when the batteries have a content of mercury or cadmium exceeding 0.025% by weight (Sweden and Switzerland).
 - B.21.101: The requirement is different (U.S.A)

DV.1 DE Replace the fifth paragraph following the amendment table with the following paragraph:

This standard must only be used with an appropriate UL 60335 part 2 standard.

DV.2 DE Deleted the sixth paragraph following the amendment table.

DV.3 DE Add the following after the last item in the first note:

The numbering system in the standard uses a space instead of a comma to indicate thousands and uses a comma instead of a period to indicate a decimal point. For example, 1 000 means 1, 000 and 1,01 means 1.01

DV.4 DE Replacement in the country clause list:

Replace "25.14.2" with "25.13.2".

DV.5 D2 Addition at the end of the clause list:

The USA differences have been reviewed and developed into UL deviations in this part one standard or in the applicable part two standards.

INTRODUCTION

It has been assumed in the drafting of this international standard that the execution of its provisions is entrusted to appropriately qualified and experienced people.

Moreover, when elaborating this standard, TC 61 took into account as far as possible the requirements given in IEC 60364⁴ so that an appliance may be installed in accordance with these wiring rules. However national wiring rules may differ.

This standard recognizes the internationally accepted level of protection against hazards such as electrical, mechanical, thermal, fire and radiation of electrical household and similar appliances when operated as in normal use taking into account the manufacturer's instructions; it also covers abnormal situations which can be expected in practice.

A product which complies with the text of this standard will not necessarily be judged to comply with the safety principles of the standard if, when examined and tested, it is found to have other features which impair the level of safety covered by these requirements.

A product employing materials or having forms of construction differing from those detailed in the requirements of this standard may be examined and tested according to the intent of the requirements and, if found to be substantially equivalent, may be judged to comply with the safety principles of the standard.

Individual countries may wish to consider the application of the standard, so far as reasonable, to appliances not mentioned in part 2, and to appliances designed on new principles.

If the functions of an appliance are covered by different parts 2 of IEC 60335, the relevant part 2 is applied to each function separately, so far as is reasonable. If applicable, the influence of one function on the other is taken into account.

Standards dealing with non-safety aspects of household appliances are:

- IEC Standards published by TC 59 concerning methods of measuring performance;
- CISPR 11¹⁾ and CISPR 14-1²⁾ concerning electromagnetic emissions;
- CISPR 14-2³⁾ and IEC 61000 series concerning electromagnetic compatibility.

* IEC 60364: Electrical installation of buildings

¹⁾ CISPR 11: Electromagnetic disturbance characteristics – Industrial, scientific and medical (ISM) radio-frequency equipment – Limits and methods of measurement

²⁾ CISPR 14-1: Limits and methods of measurement of radio disturbance characteristics of electrical motor operated and thermal appliances for household and similar purposes, electric tools and electrical apparatus

³⁾ CISPR 14-2: Electromagnetic compatibility – Requirements for household appliances, electric tools and similar apparatus – Part 2: Immunity – Product family standard

SAFETY OF HOUSEHOLD AND SIMILAR ELECTRICAL APPLIANCES –
PART 1: GENERAL REQUIREMENTS

1 Scope

This standard deals with the safety of electrical appliances for household and similar purposes, the RATED VOLTAGE of the appliances being not more than 250 V for single-phase appliances and 480 V for other appliances.

Appliances may incorporate motors, heating elements or their combination.

Appliances not intended for normal household use but which nevertheless may be a source of danger to the public, such as appliances intended to be used by laymen in shops, in light industry and on farms, are within the scope of this standard.

NOTE 1 – Examples of such appliances are catering equipment, cleaning appliances for industrial and commercial use and appliances for hairdressers.

So far as is practicable, this standard deals with the common hazards presented by appliances which are encountered by all persons in and around the home. However, this standard does not in general take into account

- the use of appliances by young children or infirm persons without supervision;
- playing with the appliance by young children.

NOTES

2 Attention is drawn to the fact that

- for appliances intended to be used in vehicles or on board ships or aircraft, additional requirements may be necessary;
- for appliances intended to be used in tropical countries, special requirements may be necessary;
- in many countries additional requirements are specified by the national health authorities, the national authorities responsible for the protection of labour, the national water supply authorities and similar authorities.

3 This standard does not apply to

- appliances intended exclusively for industrial purposes;
- appliances intended to be used in locations where special conditions prevail, such as the presence of corrosive or explosive atmosphere (dust, vapor or gas);
- radio and television receivers, record players and similar equipment (IEC 60065);

- appliances for medical purposes (IEC 60601);
- hand-held motor-operated electric TOOLS (IEC 60745);
- personal computers and similar equipment I (IEC 60950);
- transportable motor-operated electric TOOLS (IEC 61029).

1DV.1 D1 Add the following text after "playing with the appliances by young children:"

The articulate probe of figure 1DV shall replace the test finger of figure 1 when the product is:

- a) a hand-held product,
- b) a hand-held part of a product,
- c) used by children,
- d) accessible to children while the product is operating, or
- e) one that has special concerns for the accessibility of live parts or mechanical hazards.

1DV.2 DR Add the following below note 3 of last paragraph:

This standard is applicable to household and similar electrical appliances and equipment which are designed to be installed in accordance with the National Electrical Code (NEC), ANSI/NFPA 70. Annex DVD provides examples of and references for regulatory requirements that may apply to appliances.

2 Definitions

For the purpose of this standard, the following definitions apply.

2.1 Where the terms voltage and current are used they imply r.m.s. values, unless otherwise specified.

2.2.1 RATED VOLTAGE: Voltage assigned to the appliance by the manufacturer.

NOTE – For three-phase supply it is the voltage between phases.

2.2.2 RATED VOLTAGE RANGE: Voltage range assigned to the appliance by the manufacturer, expressed by its lower and upper limits.

2.2.3 WORKING VOLTAGE: Maximum voltage to which the part under consideration is subjected when the appliance is supplied at its RATED VOLTAGE and operating under NORMAL OPERATION.

NOTE – When deducing the WORKING VOLTAGE, the effect of transient voltages is ignored.

2.2.4 RATED POWER INPUT: Power input assigned to the appliance by the manufacturer.

2.2.5 RATED POWER INPUT RANGE: Power input range assigned to the appliance by the manufacturer, expressed by its lower and upper limits.

2.2.6 RATED CURRENT: Current assigned to the appliance by the manufacturer.

NOTE – If no current is assigned to the appliance, the RATED CURRENT is:

- for HEATING APPLIANCES, the current calculated from the RATED POWER INPUT and the RATED VOLTAGE;
- for MOTOR-OPERATED APPLIANCES, the current measured when the appliance is supplied at RATED VOLTAGE and operated under NORMAL OPERATION at RATED VOLTAGE.
- For COMBINED APPLIANCES, the current measured when the appliance is operated under NORMAL OPERATION supplied at RATED VOLTAGE.

2.2.7 RATED FREQUENCY: Frequency assigned to the appliance by the manufacturer.

2.2.8 RATED FREQUENCY RANGE: Frequency range assigned to the appliance by the manufacturer, expressed by its lower and upper limits.

2.2.9 NORMAL OPERATION: Conditions under which the appliance is operated in normal use when connected to the supply.

2.3.1 DETACHABLE CORD: Flexible cord, for supply or interconnection, intended to be connected to the appliance by means of a suitable appliance coupler.

2.3.2 INTERCONNECTION CORD: External flexible cord provided as part of a complete appliance for purposes other than connection to the supply mains.

NOTE – A remote hand-held switching device, an external interconnection between two parts of an appliance and a cord connecting an accessory to the appliance or to a separate signaling circuit are example of INTERCONNECTION CORDS.

2.3.3 SUPPLY CORD: Flexible cord, for supply purposes, which is fixed to the appliance.

2.3.4 TYPE X ATTACHMENT: Method of attachment of the SUPPLY CORD such that it can easily be replaced.

NOTES

1 The SUPPLY CORD may be specially prepared and only available from the manufacturer or its service agent.

2 A specially prepared cord may also include a part of the appliance.

2.3.5 TYPE Y ATTACHMENT: Method of attachment of the SUPPLY CORD such that any replacement is intended to be made by the manufacturer, its service agent or similar qualified person.

NOTE – TYPE Y ATTACHMENT may be used either with an ordinary flexible cord or with a special cord.

2.3.6 TYPE Z ATTACHMENT: Method of attachment of the SUPPLY CORD such that it cannot be replaced without breaking or destroying the appliance.

2.3.7 SUPPLY LEADS: Set of wires intended for connecting the appliance to fixed wiring and accommodated in a compartment within or attached to the appliance.

2.4.1 BASIC INSULATION: Insulation applied to LIVE PARTS to provide basic protection against electric shock.

NOTE – BASIC INSULATION does not necessarily include insulation used exclusively for functional purposes.

2.4.2 SUPPLEMENTARY INSULATION: Independent insulation applied in addition to the BASIC INSULATION in order to provide protection against electric shock in the event of a failure of the BASIC INSULATION.

2.4.3 DOUBLE INSULATION: Insulation system comprising both BASIC INSULATION and SUPPLEMENTARY INSULATION.

2.4.4 REINFORCED INSULATION: Single insulation applied to LIVE PARTS, which provides a degree of protection against electric shock equivalent to DOUBLE INSULATION under the conditions specified in this standard.

NOTE – It is not implied that the insulation is one homogeneous piece. The insulation may comprise several layers which cannot be tested singly as SUPPLEMENTARY INSULATION or BASIC INSULATION.

2.4.5 CLASS 0 APPLIANCE: Appliance in which protection against electric shock relies upon BASIC INSULATION; this implies that there are no means for the connection of conductive ACCESSIBLE PARTS, if any, to the protective conductor in the fixed wiring of the installation, reliance in the event of a failure of the BASIC INSULATION being placed upon the environment.

NOTE – CLASS 0 APPLIANCES have either an enclosure of insulating material which may form a part or the whole of the BASIC INSULATION, or a metal enclosure which is separated from LIVE PARTS by an appropriate insulation. If an appliance with an enclosure of insulating material has provision for earthing internal parts, it is considered to be a CLASS I APPLIANCE or CLASS 0I APPLIANCE.

2.4.6 CLASS 0I APPLIANCE: Appliance having at least BASIC INSULATION throughout and incorporating an earthing terminal but with a SUPPLY CORD without earthing conductor and a plug without earthing contact.

2.4.7 CLASS I APPLIANCE: Appliance in which protection against electric shock does not rely on BASIC INSULATION only but which includes an additional safety precaution in that conductive ACCESSIBLE PARTS are connected to the PROTECTIVE EARTHING CONDUCTOR in the fixed wiring of the installation in such a way that conductive ACCESSIBLE PARTS cannot become live in the event of a failure of the BASIC INSULATION.

NOTE – This provision includes a protective conductor in the SUPPLY CORD.

2.4.8 CLASS II APPLIANCE: Appliance in which protection against electric shock does not rely on BASIC INSULATION only but in which additional safety precautions, such as DOUBLE INSULATION OR REINFORCED INSULATION, are provided, there being no provision for protective earthing or reliance upon installation conditions.

NOTES

1 Such an appliance may be of one of the following types:

a) An appliance having a durable and substantially continuous enclosure of insulating material which envelops all metal parts, with the exception of small parts, such as nameplates, screws and rivets, which are isolated from LIVE PARTS by insulation at least equivalent to REINFORCED INSULATION; such an appliance is called an insulation-encased CLASS II APPLIANCE;

b) an appliance having a substantially continuous metal enclosure, in which DOUBLE INSULATION OR REINFORCED INSULATION is used throughout; such an appliance is called a metal-encased CLASS II APPLIANCE;

c) an appliance which is a combination of types a) and b).

2 The enclosure of an insulation-encased CLASS II APPLIANCE may form a part or the whole of the SUPPLEMENTARY INSULATION or of the REINFORCED INSULATION.

3 If an appliance with DOUBLE INSULATION OR REINFORCED INSULATION throughout has provision for earthing, it is considered to be a CLASS I or a CLASS 0I APPLIANCE.

2.4.9 CLASS II CONSTRUCTION: Part of an appliance for which protection against electric shock relies upon DOUBLE INSULATION OR REINFORCED INSULATION.

2.4.10 CLASS III APPLIANCE: Appliance in which protection against electric shock relies on supply at SAFETY EXTRA-LOW VOLTAGE and in which voltages higher than those of SAFETY EXTRA-LOW VOLTAGE are not generated.

NOTE – Appliances intended to be operated at SAFETY EXTRA-LOW VOLTAGE and having internal circuits which operate at a voltage other than SAFETY EXTRA-LOW VOLTAGE, are not included in the classification and are subject to additional requirements.

2.4.11 CLASS III CONSTRUCTION: Part of an appliance for which protection against electric shock relies upon SAFETY EXTRA-LOW VOLTAGE and in which voltages higher than those of SAFETY EXTRA-LOW VOLTAGES are not generated.

2.4.12 CREEPAGE DISTANCE: Shortest path between two conductive parts or between a conductive part and the accessible surface of the appliance, measured along the surface of the insulating material.

2.4.13 CLEARANCE: Shortest distance between two conductive parts or between a conductive part and the accessible surface of the appliance, measured through air.

2.5.1 EXTRA-LOW VOLTAGE: Voltage supplied from a source within the appliance which, when the appliance is supplied at RATED VOLTAGE does not exceed 50 V between conductors and between conductors and earth.

2.5.2 SAFETY EXTRA-LOW VOLTAGE: Voltage not exceeding 42 V between conductors and between conductors and earth, the no-load voltage not exceeding 50 V.

When SAFETY EXTRA-LOW VOLTAGE is obtained from the supply mains, it is to be through a SAFETY ISOLATING TRANSFORMER or a convertor with separate windings, the insulation of which complies with DOUBLE INSULATION or REINFORCED INSULATION requirements.

NOTE – The voltage limits specified are based on the assumption that the SAFETY ISOLATING TRANSFORMER is supplied at its RATED VOLTAGE.

2.5.2DV D1 *Replace the first paragraph by the following:*

SAFETY EXTRA-LOW VOLTAGE: Voltage not exceeding 30 Vr.m.s. or 42.4 Vpeak or dc between conductors and between conductors and earth. Where wet contact is likely to occur, the limit is 15 Vr.m.s. or 21.2 Vpeak or dc.

2.5.3 SAFETY ISOLATING TRANSFORMER: Transformer, the input winding of which is electrically separated from the output winding by an insulation at least equivalent to DOUBLE INSULATION OR REINFORCED INSULATION and which is intended to supply an appliance or circuit at SAFETY EXTRA-LOW VOLTAGE.

2.6.1 PORTABLE APPLIANCE: Either an appliance which is intended to be moved while in operation or an appliance, other than a FIXED APPLIANCE, having a mass less than 18 kg.

2.6.2 HAND-HELD APPLIANCE: PORTABLE APPLIANCE intended to be held in the hand during normal use, the motor, if any, forming an integral part of the appliance.

2.6.3 STATIONARY APPLIANCE: Either a FIXED APPLIANCE or an appliance which is not portable.

2.6.4 FIXED APPLIANCE: Appliance which is intended to be used while fastened to a support or otherwise secured in a specific situation.

NOTE – Adhesives are not recognized as a means for fastening a FIXED APPLIANCE to a support.

2.6.5 BUILT-IN APPLIANCE: FIXED APPLIANCE intended to be installed in a cabinet, in a prepared recess in a wall or in a similar situation.

2.7.1 NON-DETACHABLE PART: Part which can only be removed or opened with the aid of a TOOL or a part which fulfills the test of 22.11.

2.7.3 TOOL: Screwdriver, coin or any other object which may be used to operate a screw or similar fixing means.

2.8.1 THERMOSTAT: Temperature-sensing device, the operating temperature of which may be either fixed or adjustable and which during NORMAL OPERATION keeps the temperature of the controlled part between certain limits by automatically opening and closing a circuit.

2.8.2 TEMPERATURE LIMITER: Temperature-sensing device, the operating temperature of which may be either fixed or adjustable and which during NORMAL OPERATION operates by opening or closing a circuit when the temperature of the controlled part reaches a pre-determined value.

NOTE – It does not make the reverse operation during the normal duty cycle of the appliance. It may or may not require manual resetting.

2.8.3 THERMAL CUT-OUT: Device which during abnormal operation limits the temperature of the controlled part by automatically opening the circuit or by reducing the current and constructed so that its setting cannot be altered by the user.

2.8.4 SELF-RESETTING THERMAL CUT-OUT: THERMAL CUT-OUT which automatically restores the current after the relevant part of the appliance has cooled down sufficiently.

2.8.5 NON-SELF-RESETTING THERMAL CUT-OUT: THERMAL CUT-OUT which requires a manual operation for resetting or replacement of a part, in order to restore the current.

NOTE – Manual operation includes disconnection of the supply.

2.8.6 PROTECTIVE DEVICE: Device, the operation of which prevents a hazardous situation under abnormal operation conditions.

2.8.7 THERMAL LINK: THERMAL CUT-OUT which operates only once and then requires partial or complete replacement.

2.9.1 ALL-POLE DISCONNECTION: For single-phase appliances disconnection of both supply conductors by a single initiating action or, for three-phase appliances, disconnection of all supply conductors except the earthed (grounded) conductor, by a single initiating action.

NOTE – The PROTECTIVE EARTHING CONDUCTOR is not considered to be a supply conductor.

2.9.2 OFF POSITION: Stable position of a switching device in which the circuit controlled by the switch is disconnected from its supply.

NOTE – The OFF POSITION does not imply an ALL-POLE DISCONNECTION.

2.9.3 ACCESSIBLE PART: Part or surface which can be touched by means of the test finger of figure 1, including any conductive part connected to accessible metal parts.

2.9.4 LIVE PART: Any conductor or conductive part intended to be energized in normal use, including a neutral conductor but, by convention, not a PEN conductor.

NOTES

1 Parts, accessible or not, complying with 8.1.4 are not considered to be LIVE PARTS.

2 A PEN conductor is a protective earthed neutral conductor combining the functions of both protective conductor and neutral conductor.

2.9.5 VISIBLE GLOWING HEATING ELEMENT: Heating element which is partly or completely visible from the outside of the appliance and has a temperature of at least 650EC when the appliance has been operated under NORMAL OPERATION at RATED POWER INPUT until steady conditions have been established.

2.9.6 HEATING APPLIANCE: Appliance incorporating heating elements but without any motor.

2.9.7 MOTOR-OPERATED APPLIANCE: Appliance incorporating motors but without any heating element.

NOTE - Magnetically driven appliances are considered to be MOTOR-OPERATED APPLIANCES.

2.9.8 COMBINED APPLIANCE: Appliance incorporating heating elements and motors.

2.9.9 USER MAINTENANCE: Any maintenance operation stated in the instructions for use or marked on the appliance which the user is intended to perform.

2.10.1 ELECTRONIC COMPONENT: Part in which conduction is achieved principally by electrons moving through a vacuum, gas or semiconductor.

NOTE - Neon indicators are not considered to be ELECTRONIC COMPONENTS.

2.10.2 ELECTRONIC CIRCUIT: Circuit incorporating at least one ELECTRONIC COMPONENT.

2.10.3 PROTECTIVE IMPEDANCE: Impedance connected between LIVE PARTS and accessible conductive parts of Class II construction such that the current, in normal use and under likely fault conditions in the appliance, is limited to a safe value.

2.10.4 PTC HEATING ELEMENT: Element intended for heating consisting mainly of positive temperature coefficient resistors which are thermally sensitive and which have a rapid non-linear increase in resistance when the temperature is raised through a particular range.

2.11DV D2 Addition:

LIMITED POWER SOURCE: A source complying with subclause 8.3DV.

2.12DV D2 Addition:

PROTECTIVE EARTHING CONDUCTOR: A conductor in the building installation wiring, or in the power SUPPLY CORD, connecting a main protective earthing terminal in the equipment to an earth point in the building installation.

2.13DV D2 Addition:

PROTECTIVE BONDING CONDUCTOR: A conductor in the equipment, or a combination of conductive parts in the equipment, connecting a main protective earthing terminal to a part of the equipment that is required to be earthed.

3 General requirement

Appliances shall be constructed so that in normal use they function safely so as to cause no danger to persons or surroundings, even in the event of carelessness that may occur in normal use.

In general this principle is achieved by fulfilling the relevant requirements specified in this standard and compliance is checked by carrying out all the relevant tests.

NOTES

1 A product which complies with the text of this standard will not necessarily be judged to comply with the safety principles of the standard if, when examined and tested, it is found to have other features which impair the level of safety covered by these requirements.

2 A product employing materials or having forms of construction differing from those detailed in the requirements of this standard may be examined and tested according to the intent of the requirements and, if found to be substantially equivalent, may be judged to comply with the standard.

3 This standard recognizes the internationally accepted level of protection against hazards such as electrical, mechanical, thermal, fire and radiation of electrical household and similar appliances when operated as in normal use taking into account the instructions for use; it also covers abnormal situations likely to be encountered in practice.

3DV DE Modification of the first paragraph to add the following:

Examples of the phrase "or surroundings" are water damage, discoloration, etc.

4 General conditions for the tests

Unless otherwise specified, the tests are carried out in accordance with this clause.

4.1 *Tests according to this standard are type tests.*

4.2 *The tests are carried out on a single appliance, which shall withstand all the relevant tests. However, the tests of clauses 20, 22 (except 22.11 and 22.18) to 26, 28, 30 and 31 may be carried out on separate appliances.*

NOTES

1 Additional samples may be required for example if the appliance can be supplied with different voltages.

If the test of annex C has to be made, six samples of the motor are needed.

The testing of components may require the submission of additional samples of these components.

If the tests of 24.1.3 are carried out, three switches or three additional appliances are needed.

If an intentionally weak part becomes open-circuit during the tests of clause 19, an additional appliance is needed.

If the tests of annex R are carried out, four additional transformers are needed.

2 The cumulative stress resulting from successive tests on ELECTRONIC CIRCUITS is to be avoided. It may be necessary to replace components or to use additional samples. The number of additional samples should be kept to a minimum by an evaluation of the relevant ELECTRONIC CIRCUITS.

3 If an appliance has to be dismantled in order to carry out a test, care is to be taken to insure that it is reassembled as originally supplied. In case of doubt subsequent tests may be carried out on a separate sample.

4.2DV D2 Replace the first paragraph with the following:

The tests may be carried out on a number of samples as agreed upon by the parties involved.

4.3 *The tests are carried out in the order of the clauses. However, the test of 22.11 on the appliance at room temperature is made before the tests of clause 8.*

If it is evident from the construction of the appliance that a particular test is not applicable, the test is not made.

4.3DV D2 Replace the first paragraph with the following:

Unless specified otherwise, the tests may be carried out in any order. However, the test of 13 is conducted when the sample is in a well-heated condition simulating NORMAL OPERATION (clause 11) of the appliance: the test of 16 is conducted immediately after the test of 15 and the test of 22.11 is conducted before the test 8.

4.4 *When testing appliances which are also supplied by other energies such as gas, the influence of their consumption has to be taken into account.*

4.5 *The tests are carried out with the appliance or any movable part of it placed in the most unfavourable position which may occur in normal use.*

4.6 *Appliances provided with controls or switching devices are tested with these controls or devices adjusted to their most unfavourable setting, if the setting can be altered by the user.*

NOTES

1 If the adjusting means of the control is accessible without the aid of a **TOOL**, this subclause applies whether the setting can be altered by hand or with the aid of a **TOOL**. If the adjusting means is not accessible without the aid of a **TOOL** and if the setting is not intended to be altered by the user, this subclause does not apply.

2 Adequate sealing is regarded as preventing alteration of the setting by the user.

4.7 *The tests are carried out in a draught free location and in general at an ambient temperature of 20EC ±5EC.*

If the temperature attained by any part is limited by a temperature sensitive device or is influenced by the temperature at which a change of state occurs, for example when water boils, the ambient temperature is maintained at 23EC ± 2EC in case of doubt.

4.8.1 *Appliances for a.c. only are tested with a.c. at RATED FREQUENCY, if marked, and those for a.c./d.c. are tested at the more unfavourable supply.*

Appliances for a.c. which are not marked with RATED FREQUENCY or marked with a frequency range of 50 Hz to 60 Hz are tested with either 50 Hz or 60 Hz, whichever is the more unfavourable.

4.8.2 *Appliances having more than one RATED VOLTAGE are tested on the basis of the most unfavourable voltage.*

When it is specified, for MOTOR-OPERATED APPLIANCES and COMBINED APPLIANCES marked with a RATED VOLTAGE RANGE, that the supply voltage is equal to the RATED VOLTAGE multiplied by a factor, the supply voltage is equal to

- the upper limit of the RATED VOLTAGE RANGE multiplied by this factor, if greater than 1;*
- the lower limit of the RATED VOLTAGE RANGE multiplied by this factor, if smaller than 1.*

When a factor is not specified, the supply voltage is the most unfavourable within the RATED VOLTAGE RANGE.

NOTES

1 If a **HEATING APPLIANCE** has a **RATED VOLTAGE RANGE**, the upper limit of the voltage range will usually be the most unfavourable voltage within the range.

2 For **COMBINED APPLIANCES** and **MOTOR-OPERATED APPLIANCES** and for appliances having more than one **RATED VOLTAGE** or **RATED VOLTAGE RANGE**, it may be necessary to make some of the tests at the minimum, the mean and the maximum values of the **RATED VOLTAGE** or the **RATED VOLTAGE RANGE** in order to establish the most unfavourable voltage.

4.8.3 When it is specified, for HEATING APPLIANCES and COMBINED APPLIANCES marked with a RATED POWER INPUT RANGE, that the power input is equal to the RATED POWER INPUT multiplied by a factor, the power input is equal to

- the upper limit of the RATED POWER INPUT RANGE multiplied by this factor, if greater than 1;
- the lower limit of the RATED POWER INPUT RANGE multiplied by this factor, if smaller than 1.

When a factor is not specified, the power input is the most unfavourable within the RATED POWER INPUT RANGE.

4.8.4 For appliances marked with a RATED VOLTAGE RANGE and RATED POWER INPUT corresponding to the mean of the RATED VOLTAGE RANGE, when it is specified that the power input is equal to RATED POWER INPUT multiplied by a factor, the power input is equal to:

- the calculated power input corresponding to the upper limit of the RATED VOLTAGE RANGE multiplied by this factor if greater than 1;
- the calculated power input corresponding to the lower limit of the RATED VOLTAGE RANGE multiplied by this factor if smaller than 1.

When a factor is not specified, the power input corresponds to the power input at the most unfavourable voltage within the RATED VOLTAGE RANGE.

4.9 When alternative heating elements or accessories are made available by the appliance manufacturer, the appliance is tested with those elements or accessories which give the most unfavourable results.

4.10 The tests are made on the appliance as supplied. However, an appliance constructed as a single appliance but supplied in a number of units is tested after assembly in accordance with the instructions provided with the appliance.

BUILT-IN APPLIANCES and FIXED APPLIANCES are installed in accordance with the instructions provided with the appliance before testing.

4.11 Appliances intended to be supplied by means of a flexible cord are tested with the appropriate flexible cord connected to the appliance.

4.12 When, for COMBINED APPLIANCES and HEATING APPLIANCES, it is specified that the appliance has to operate at a power input multiplied by a factor, this applies only to heating elements without appreciable positive temperature coefficient of resistance.

For other heating elements, other than PTC HEATING ELEMENTS, the supply voltage is determined by supplying the appliance at RATED VOLTAGE until the heating element reaches its operating temperature. The supply voltage is then rapidly increased to the value necessary to give the power input required for the relevant test, this value of the supply voltage being maintained throughout the test.

NOTE – In general, the temperature coefficient is considered to be appreciable if, at RATED VOLTAGE, the power input of the appliance in cold condition differs by more than 25% from the power input at operating temperature.

4.13 The tests for appliances with PTC HEATING ELEMENTS are made at a voltage corresponding to the specified power input. When a power input greater than the RATED POWER INPUT is specified, the factor for multiplying the voltage is equal to the square root of the factor for multiplying the power input.

4.14 If CLASS 0I APPLIANCES or CLASS I APPLIANCES have accessible metal parts which are not earthed and are not separated from LIVE PARTS by an intermediate metal part which is earthed, such parts are checked for compliance with the appropriate requirements specified for CLASS II CONSTRUCTION.

If CLASS 0I APPLIANCES or CLASS I APPLIANCES have accessible non-metallic parts, such parts are checked for compliance with the appropriate requirements specified for CLASS II CONSTRUCTION unless these parts are separated from LIVE PARTS by an intermediate metal part which is earthed.

4.15 If appliances have parts operating at SAFETY EXTRA-LOW VOLTAGE, such parts are checked for compliance with the appropriate requirements specified for CLASS III CONSTRUCTION.

4.16 When testing ELECTRONIC CIRCUITS, the supply is to be free from perturbations from external sources that can influence the results of the tests.

4.17 Appliances powered by rechargeable batteries are tested according to annex B.

5 Void

6 Classification

6.1 Appliances shall be of one of the following classes with respect to protection against electric shock:

CLASS 0, CLASS 0I, CLASS I, CLASS II, CLASS III.

Compliance is checked by inspection and by the relevant tests.

6.2 Appliances shall have the appropriate degree of protection against harmful ingress of water.

Compliance is checked by inspection and by the relevant tests.

NOTE – The degrees of protection against harmful ingress of water are given in IEC 60529.

7 Marking and instructions

7.1 Appliances shall be marked with the

- RATED VOLTAGE or RATED VOLTAGE RANGE in volts;
- symbol for nature of supply, unless the RATED FREQUENCY is marked;
- RATED POWER INPUT in watts or kilowatts or RATED CURRENT in amperes;
- name, trade mark or identification mark of the manufacturer or responsible vendor;
- model or type reference;
- symbol for CLASS II CONSTRUCTION, for CLASS II APPLIANCES only;
- IP number according to degree of protection against ingress of water, other than IPX0.

Compliance is checked by inspection.

NOTES

- 1 The first numeral of the IP number need not be marked on the appliance.**
- 2 Additional markings are allowed provided they do not give rise to misunderstanding.**
- 3 If components are marked separately, the marking of the appliance and that of the components is to be such that there can be no doubt with regard to the marking of the appliance itself.**

7.2 STATIONARY APPLIANCES for multiple supply shall be marked with the substance of the following:

Warning: Before obtaining access to terminals, all supply circuits must be disconnected.

This warning shall be placed in the vicinity of the terminal cover.

Compliance is checked by inspection.

7.3 Appliances having a range of rated values and which can be operated without adjustment throughout the range, shall be marked with the lower and upper limits of the range separated by a hyphen.

NOTE 1 – Example: 115-230 V: The appliance is suitable for any value within the marked range (a curling iron with a PTC HEATING ELEMENT).

Appliances having different rated values and which have to be adjusted for use at a particular value by the user or installer, shall be marked with the different values separated by an oblique stroke.

NOTES

- 2 Example: 115/230 V: The appliance is only suitable for the marked values (a shaver with a selector switch).**
- 3 This requirement is also applicable to appliances with provision for connection to both single-phase and multi-phase supplies.**

Example: 230 V/400 V: The appliance is only suitable for the voltage values indicated where 230 V is for single-phase operation and 400 V for three-phase operation (a dishwasher with terminals for both supplies).

Compliance is checked by inspection.

7.4 If the appliance can be adjusted for different RATED VOLTAGES, the voltage to which the appliance is adjusted shall be clearly discernible.

NOTE – For appliances where frequent changes in voltage setting are not required, this requirement is considered to be met if the RATED VOLTAGE to which the appliance is to be adjusted can be determined from a wiring diagram fixed to the appliance. The wiring diagram may be on the inside of a cover which has to be removed to connect the supply conductors. It is not to be on a label loosely attached to the appliance.







Compliance is checked by inspection.







7.5 For appliances marked with more than one RATED VOLTAGE or with more than one RATED VOLTAGE RANGE, the RATED POWER INPUT for each of these voltages or ranges shall be marked. However, if the difference between the limits of a RATED VOLTAGE RANGE does not exceed 10 % of the mean value of the range, the marking for RATED POWER INPUT may be related to the mean value of the range.

The upper and lower limits of the RATED POWER INPUT shall be marked on the appliance so that the relation between input and voltage is clear.

Compliance is checked by inspection.

7.6 When symbols are used, they shall be as follows:

| | | |
|--|-------|--|
| V | | volts |
| A | | amperes |
| Hz | | hertz |
| W | | watts |
| F | | farads |
| l | | litres |
| g | | grammes |
| Pa | | pascals |
| bar | | bars (see note 4) |
| h | | hours |
| min | | minutes |
| s | | seconds |
|  | | or d.c. direct current |
|  | | or a.c. alternating current |
| 2  | | two-phase alternating current |
| 2N  | | two-phase alternating current with neutral |
| 3  | | three-phase alternating current |
| 3N  | | three-phase alternating current with neutral |

| | | |
|---|-------|--|
|  | | RATED CURRENT of the appropriate fuse-link in amperes |
|  | | time-lag miniature fuse-link where X is the symbol for the time/current characteristic as given in IEC 60127 |
|  | | information symbol |
|  | | caution |
|  | | protective earth |
|  | | CLASS II APPLIANCE |
| IPXX | | IP number |

If the first numeral for the IP numbering is omitted, the omitted numeral shall be replaced by the letter X, for example IPX3.

The symbol for nature of supply shall be placed next to the marking for RATED VOLTAGE.

The dimensions for the symbol for CLASS II APPLIANCES shall be such that the length of the sides of the outer square is about twice the length of the sides of inner square.

The symbol for CLASS II APPLIANCES shall be placed so that it will be obvious that it is a part of the technical information and is unlikely to be confused with any other marking.

When other units are used the units and their symbols shall be those of the international standardized system.

Compliance is checked by inspection and by measurement.

NOTES

- 1 Multiple or submultiple units are also allowed.
- 2 Additional symbols are allowed provided they do not give rise to misunderstanding.
- 3 Symbols specified in IEC 417 may be used.
- 4 Bars may be used but only together with pascals and placed in brackets.

7.6DV D2 Addition

See 27.5DV.11 for additional requirements covering the class II appliance symbol.

7.7 Appliances to be connected to more than two supply conductors and appliances for multiple supply shall have a connection diagram fixed to them, unless the correct mode of connection is obvious.

Compliance is checked by inspection.

NOTES

- 1 The correct mode of connection is considered to be obvious if for three-phase appliances the terminals for the supply conductors are indicated by arrows pointing towards the terminals. The earthing conductor is not a supply conductor.
- 2 Marking in words is an acceptable means of indicating the correct mode of connection.
- 3 The connection diagram may be the wiring diagram referred to in 7.4.

7.8 Except for TYPE Z ATTACHMENT, terminals used for connection to the supply mains shall be indicated as follows:

- terminals intended exclusively for the neutral conductor shall be indicated by the letter N;
- protective earthing terminals shall be indicated by the symbol



IEC417, Symbol 5019

These indications shall not be placed on screws, removable washers or other parts which can be removed when conductors are being connected.

If, for single-phase CLASS I APPLIANCES intended to be permanently connected to fixed wiring, a single-pole PROTECTIVE DEVICE is inserted in the phase conductor inside the appliance, the corresponding terminal shall be clearly indicated.

Compliance is checked by inspection.

7.9 Unless it is obviously unnecessary, switches which may give rise to a hazard when operated shall be marked or placed so as to indicate clearly which part of the appliance they control.

Indications used for this purpose shall, wherever practicable, be comprehensible without a knowledge of languages or national standards.

Compliance is checked by inspection.

7.10 The different positions of switches on STATIONARY APPLIANCES and the different positions of controls on all appliances shall be indicated by figures, letters or other visual means.

NOTE 1 – This requirement also applies to switches which are part of a control.

If figures are used for indicating the different positions, the OFF POSITION shall be indicated by the figure 0 and the position for a greater output, input, speed, cooling effect, etc., shall be indicated by a higher figure.

The figure 0 shall not be used for any other indication, unless it is positioned and associated with other numbers so that it does not give rise to confusion with the indication of the OFF POSITION.

Compliance is checked by inspection.

NOTE 2 – The figure 0 may, for example, also be used on a digital programming keyboard.

7.11 Controls intended to be adjusted during installation or in normal use shall be provided with an indication for the direction of adjustment.

Compliance is checked by inspection.

NOTE – An indication of + and - is sufficient.

7.12 Instructions for use shall be provided with the appliance so that the appliance can be used safely.

Compliance is checked by inspection.

NOTE – Instructions for use may be marked on the appliance as long as they are visible in normal use.

7.12.1 If it is necessary to take special precautions for installation or USER MAINTENANCE, details of these shall be supplied.

Compliance is checked by inspection.

7.12.2 If a STATIONARY APPLIANCE is not provided with a SUPPLY CORD and a plug or with other means for disconnection from the supply having a contact separation of at least 3 mm in all poles, the instructions shall state that means for disconnection must be incorporated in the fixed wiring according to the wiring rules.

Compliance is checked by inspection.

7.12.3 If the insulation of the supply wires of an appliance intended to be permanently connected to fixed wiring can come into contact with parts which have a temperature rise exceeding 50 K during the test of clause 11, the instructions shall state that the appliance must be connected by means of wires having an appropriate temperature rating (T-marking).

Compliance is checked by inspection and during the test of clause 11.

NOTE – This requirement will become applicable as soon as there is an IEC standard for high temperature cords and wires.

7.12.4 The instructions for BUILT-IN APPLIANCES shall include clear information with regard to the following:

- dimensions of the space to be provided for the appliance;
- dimensions and position of the means for supporting and fixing the appliance within this space;
- minimum distances between the various parts of the appliance and the surrounding parts of the fitment;
- minimum dimensions of ventilating openings and their correct arrangement;
- connection of the appliance to the supply and the interconnection of any separate components;
- necessity to have the plug accessible after installation, unless the appliance is provided with a switch complying with 24.3.

Compliance is checked by inspection.

7.12.5 The instructions shall contain the substance of the following:

- for appliances with TYPE X ATTACHMENT having a specially prepared cord:

If the SUPPLY CORD is damaged, it must be replaced by a special cord or assembly available from the manufacturer or its service agent;

- for appliances with TYPE Y ATTACHMENT:

If the SUPPLY CORD is damaged, it must be replaced by the manufacturer or its service agent or a similarly qualified person in order to avoid a hazard;

- for appliances with TYPE Z ATTACHMENT:

The SUPPLY CORD cannot be replaced. If the cord is damaged the appliance should be scrapped.

Compliance is checked by inspection.

7.13 Instructions and other texts required by this standard shall be written in the official language of the country in which the appliance is to be sold.

Compliance is checked by inspection.

7.14 The markings required by the standard shall be clearly legible and durable.

Compliance is checked by inspection and by rubbing the marking by hand for 15 s with a piece of cloth soaked with water and again for 15 s with a piece of cloth soaked with petroleum spirit.

After all the tests of this standard, the marking shall be clearly legible, it shall not be easily possible to remove marking plates and they shall show no curling.

NOTES

1 In considering the durability of the marking, the effect of normal use is taken into account. For example, marking by means of paint or enamel, other than vitreous enamel, on containers that are likely to be cleaned frequently, is not considered to be durable.

2 The petroleum spirit to be used for the test is aliphatic solvent hexane having a maximum aromatics content of 0,1% by volume, a kauri-butanol value of 29, an initial boiling point of approximately 65EC, a dry point of approximately 69EC and a specific mass of approximately 0,66 kg/l.

7.15 The markings specified in 7.1 to 7.5 shall be on a main part of the appliance.

Markings on the appliance shall be clearly discernible from the outside of the appliance but if necessary after removal of a cover. For PORTABLE APPLIANCES it shall be possible to remove or open this cover without the aid of a TOOL.

For STATIONARY APPLIANCES at least the name or trade mark or identification mark of the manufacturer or responsible vendor and the model or type reference shall be visible when the appliance is installed as in normal use. These markings may be beneath a detachable cover. Other markings may be beneath a cover only if they are near to the terminals.

For FIXED APPLIANCES, this requirement applies after the appliance has been installed according to the instructions provided with the appliance.

Indications for switches and controls shall be placed on or near these components. They shall not be placed on parts which can be positioned or repositioned in such a way that the marking is misleading.

Compliance is checked by inspection.

7.16 If compliance with this standard depends upon the operation of a replaceable THERMAL LINK or fuse link, the reference number or other means for identifying the link shall be marked at such a place that it is clearly visible when the appliance has been dismantled to the extent necessary for replacing the link.

NOTE – Marking on the link is allowed as long as the marking is legible after the link has functioned.

This requirement does not apply to links which can only be replaced together with a part of the appliance.

Compliance is checked by inspection.

8 Protection against access to LIVE PARTS

8.1 Appliances shall be constructed and enclosed so that there is adequate protection against accidental contact with LIVE PARTS.

Compliance is checked by inspection and by the tests of 8.1.1 to 8.1.3 as applicable, taking into account 8.1.4 and 8.1.5.

8.1.1 The requirement of 8.1 applies for all positions of the appliance when it is operated as in normal use, even after opening lids and doors and removal of DETACHABLE PARTS.

NOTE – This excludes the use of screw-type fuses and screw-type miniature circuit breakers which are accessible without the aid of a TOOL.

Lamps located behind a detachable cover are not removed, provided the appliance can be isolated from the supply by means of a plug or an all-pole switch. However, during insertion or removal of lamps which are located behind a detachable cover, protection against contact with LIVE PARTS of the lamp cap shall be ensured.

The test finger of figure 1 is applied without appreciable force, the appliance being in every possible position except that appliances normally used on the floor and having a mass exceeding 40 kg are not tilted. Through openings, the test finger is applied to any depth that the finger will permit and is rotated or angled before, during and after insertion to any position. If the opening does not allow the entry of the finger, the force on the finger in the straight position is increased to 20 N. If the finger then enters the opening, the test is repeated with the finger in the angled position.

It shall not be possible to touch LIVE PARTS or LIVE PARTS protected only by lacquer, enamel, ordinary paper, cotton, oxide film, beads or sealing compound except self-hardening resins, with the test finger.

8.1.1DV D1 Add the following after the third paragraph:

The articulate probe of figure 1DV shall replace the test finger of figure 1 when the product is:

- a) a hand-held product,**
- b) a hand-held part of a product,**
- c) used by children,**
- d) accessible to children while the product is operating, or**
- e) one that has special concerns for the accessibility of LIVE PARTS or mechanical hazards.**

8.1.2 *The test pin of figure 2 is applied without appreciable force through openings in CLASS 0 APPLIANCES, CLASS II APPLIANCES or CLASS II CONSTRUCTIONS, except for those giving access to lamp caps and LIVE PARTS in socket-outlets.*

The test pin is also applied through openings in earthed metal enclosures having a non conductive coating such as enamel or lacquer.

It shall not be possible to touch LIVE PARTS with the test pin.

NOTE – Appliance outlets are not considered to be socket-outlets.

8.1.3 *Instead of the test finger and the test pin, for appliances other than those of CLASS II, the test probe of figure 3 is applied without appreciable force to LIVE PARTS of VISIBLY GLOWING HEATING ELEMENTS, all poles of which can be disconnected by a single switching action. It is also applied to parts supporting such elements, provided that it is obvious from the outside of the appliance, without removing covers and similar parts, that these supporting parts are in contact with the element.*

It shall not be possible to touch these LIVE PARTS.

NOTE – For appliances provided with a SUPPLY CORD and without a switching device in their supply circuit, the withdrawal of the plug from a socket-outlet is considered to be a single switching action.

8.1.4 An ACCESSIBLE PART is not considered to be live if

– the part is supplied at SAFETY EXTRA-LOW VOLTAGE provided that:

- for a.c., the peak value of the voltage does not exceed 42,4 V;
- for d.c., the voltage does not exceed 42,4 V;

or

– the part is separated from LIVE PARTS by PROTECTIVE IMPEDANCE.

In the case of PROTECTIVE IMPEDANCE, the current between the part and the supply source shall not exceed 2mA for d.c. and its peak value shall not exceed 0,7 mA for a.c. and moreover:

– for voltages having a peak value over 42,4 V up to and including 450 V, the capacitance shall not exceed 0,1 μ F;

– for voltages having a peak value over 450 V up to and including 15 kV, the discharge shall not exceed 45 μ C.

Compliance is checked by measurement with the appliance supplied at RATED VOLTAGE.

Voltages and currents are measured between the relevant parts and each pole of the supply source. Discharges are measured immediately after the interruption of the supply.

NOTE – Details of a suitable measuring circuit for leakage current are given in annex G.

8.1.5 LIVE PARTS of BUILT-IN APPLIANCES, FIXED APPLIANCES and appliances delivered in separate units, shall be protected at least by BASIC INSULATION before installation or assembly.

Compliance is checked by inspection and by the test of 8.1.1.

8.2 CLASS II APPLIANCES and CLASS II CONSTRUCTIONS shall be constructed and enclosed so that there is adequate protection against accidental contact with BASIC INSULATION and metal parts separated from LIVE PARTS by BASIC INSULATION only.

It shall only be possible to touch parts which are separated from LIVE PARTS by DOUBLE INSULATION OR REINFORCED INSULATION.

Compliance is checked by inspection and by applying the test finger of figure 1, as described in 8.1.1.

NOTES

1 This requirement applies for all positions of the appliance when it is operated as in normal use, even after opening lids and doors and removal of DETACHABLE PARTS.

2 BUILT-IN APPLIANCES and FIXED APPLIANCES are tested after installation.

8.3DV D1 Addition of 8.3DV.1 to 8.3 DV.6:

8.3DV.1 Limited power sources

8.3DV.1.1 A LIMITED POWER SOURCE operated from an a.c. mains supply, or a battery operated limited power source that is recharged from an a.c. mains supply while supplying the load, shall incorporate an isolating transformer.

8.3DV.1.2 A LIMITED POWER SOURCE shall have a SAFETY EXTRA-LOW VOLTAGE output and comply with one of the following:

– the output is inherently limited in compliance with table 8.3DV.1.2.1

– an impedance limits the output in compliance with table 8.3DV.1.2.1 If a positive temperature coefficient device is used, it shall pass the tests specified in the third edition of UL 60730-1, clauses 15 and 17, and clauses J15 and J17; or

– an overcurrent PROTECTIVE DEVICE is used and the output is limited in compliance with table 8.3DV.1.2.2:

– a regulating network limits the output in compliance with table 8.3DV.1.2.1, both under normal operating conditions and after any single fault in the regulating network (open circuit or short circuit); or

– a regulating network limits the output in compliance with table 8.3DV.1.2.1 under normal operating conditions, and an overcurrent PROTECTIVE DEVICE limits the output in compliance with table 8.3DV.1.2.2 after any single fault in the regulating network (open circuit or short circuit).

Table 8.3DV.1.2.1 D1 Addition:

Table 8.3DV.1.2.1 – Limits for inherently LIMITED POWER SOURCES (see 8.3DV)

| Output voltage ¹⁾ (U_{OC}) | | Output current ²⁾ (I_{SC}) | Apparent power ³⁾ (S) VA |
|---|-----------------------|---|---|
| V a.c. | V d.c. | A | VA |
| # 20 | # 20 | # 8,0 | # $5 \times U_{OC}$ |
| $20 < U_{OC} \# 30$ | $20 < U_{OC} \# 30$ | # 8,0 | # 100 |
| – | $30 < U_{OC} \# 42.4$ | # $150 / U_{OC}$ | # 100 |

1) U_{OC} : Output voltage measured with all load circuits disconnected. Voltages are for substantially sinusoidal a.c. and ripple free d.c. For non-sinusoidal a.c. and d.c. with ripple greater than 10% of the peak, the peak voltage shall not exceed 42.4 V.

2) I_{SC} : Maximum output current with any non-capacitive load, including a short circuit measured 60 s after application of the load.

3) S (VA): Maximum output VA with any load. Initial transients lasting less than 60 s are permitted to exceed the limit.

Table 8.3DV.1.2.2 D1 Addition:

Table 8.3DV.1.2.2 – Limits for power sources not inherently limited

(Overcurrent PROTECTIVE DEVICE required)

| Output Voltage ¹⁾ | | Output current ²⁾ (I_{SC}) A | Apparent power ³⁾ (S) VA | Current rating of overcurrent PROTECTIVE DEVICE A |
|------------------------------|-------------------------|---|---|---|
| (U_{OC}) | | | | |
| V a.c. | V d.c. | | | |
| # 20 | # 20 | $1\ 000/U_{OC}$ | 250 | 5,0 |
| $20 < U_{OC} \leq 30$ | $20 < U_{OC} \leq 30$ | | | $100/U_{OC}$ |
| – | $30 < U_{OC} \leq 42.4$ | | | $100/U_{OC}$ |

1) U_{OC} : Output voltage measured with all load circuits disconnected. Voltages are for substantially sinusoidal a.c. and ripple free d.c. For non-sinusoidal a.c. and for d.c. with ripple greater the 10% of the peak, the peak voltage shall not exceed 42,4 V.

2) I_{SC} : Maximum output current with any non-capacitive load, including a short circuit, measured 60 s after application of the load. Current limiting impedances in the equipment remain in the circuit during measurement, but overcurrent PROTECTIVE DEVICES are bypassed.

3) VA: Maximum output VA with any load. Current limiting impedances in the equipment remain in the circuit during measurement, but overcurrent PROTECTIVE DEVICES are bypassed. Initial transients lasting less than 60 s are permitted to exceed the limit.

NOTE – The reason for making measurements with overcurrent PROTECTIVE DEVICES bypassed is to determine the amount of energy that is available to cause the possible overheating during the operating time of the overcurrent PROTECTIVE DEVICES.

8.3DV.1.3 Where an overcurrent PROTECTIVE DEVICE is used, it shall be a fuse which is not accessible to the user or a non-adjustable, non-autoreset, electromechanical device.

8.3DV.1.4 Compliance is checked by inspection and measurement and, where appropriate, by examination of the manufacturer's data for batteries. Batteries are to be fully charged when conducting the measurements for U_{OC} and I_{SC} according to tables 8.3DV.1.2.1 and 8.3DV.1.2.2

8.3DV.1.5 The load referenced in items 2) and 3) of tables 8.3DV.1.2.1 and 8.3DV.1.2.2, is adjusted to develop maximum current and power transfer respectively. Single Faults in a regulating network are applied under these current and power conditions.

9 Starting of motor-operated appliances

Requirements and tests are specified in part 2 when necessary.

10 Power input and current

10.1 The power input of the appliance at RATED VOLTAGE and at normal operating temperature shall not deviate from the RATED POWER INPUT by more than the deviation shown in table 1.

The deviation for MOTOR-OPERATED APPLIANCES applies for COMBINED APPLIANCES if the power input of the motors is more than 50% of the total RATED POWER INPUT.

NOTE 1 – In case of doubt the power input of the motors is measured separately.

Compliance is checked by measurement when the power input has stabilized:

- all circuits which can operate simultaneously being in operation;
- the appliance being supplied at RATED VOLTAGE;
- the appliance being operated under NORMAL OPERATION.

If the power input varies throughout the operating cycle, the power input is determined as the mean value of the power input occurring during a representative period.

NOTES

2 The test is made at both the upper and lower limits of the ranges for appliances marked with one or more RATED VOLTAGE RANGES, unless the marking of the RATED POWER INPUT is related to the mean value of the relevant voltage range, in which case the test is made at a voltage equal to the mean value of that range.

3 The permissible deviations apply for both limits of the range for appliances marked with a RATED VOLTAGE RANGE having limits differing by more than 10% of the mean value of the range.

4 The negative deviation is not limited for MOTOR-OPERATED APPLIANCES and for all appliances having a RATED POWER INPUT of 25 W or less.

Table 1 - Power input deviation

| Type of appliance | RATED POWER INPUT | Deviation |
|--|-------------------|---|
| | W | |
| All appliances | # 25 | + 20% |
| HEATING APPLIANCES and COMBINED APPLIANCES | > 25 and # 200 | ± 10% |
| | > 200 | + 5% or 20 W (whichever is the greater) - 10% |
| MOTOR-OPERATED APPLIANCES | > 25 and # 300 | +20% |
| | > 300 | + 15% or 60 W (whichever is the greater) |

10.2 If an appliance is marked with RATED CURRENT, the current at normal operating temperature shall not deviate from RATED CURRENT by more than the corresponding deviation shown in table 2.

Compliance is checked by measurement when the current has stabilized:

- all circuits which can operate simultaneously being in operation;
- the appliance being supplied at RATED VOLTAGE;
- the appliance being operated under NORMAL OPERATION.

If the current varies throughout the operating cycle, the current is determined as the mean value of the current occurring during a representative period.

NOTES

1 The test is made at both the upper and lower limits of the ranges for appliances marked with one or more RATED VOLTAGE RANGES, unless the marking of the RATED CURRENT is related to the mean value of the relevant voltage range, in which case the tests are made at a voltage equal to the mean value of that range.

2 The permissible deviations apply for both limits of the range for appliances marked with a RATED VOLTAGE RANGE having limits differing by more than 10% of the mean value of the range.

3 The negative deviation is not limited for MOTOR-OPERATED APPLIANCES and for all appliances having a RATED CURRENT of 0,2 A or less.

Table 2 – Current deviation

| Type of appliance | RATED CURRENT | Deviation |
|--|-----------------|--|
| | A | |
| All appliances | # 0,2 | + 20% |
| HEATING APPLIANCES and COMBINED APPLIANCES | > 0,2 and # 1,0 | ± 10% |
| | > 1,0 | + 5% or 0,10 A (whichever is the greater) - 10% |
| MOTOR-OPERATED APPLIANCES | > 0,2 and # 1,5 | + 20% |
| | > 1,5 | + 15% or 0,30 A (whichever is the greater) |

11 Heating

11.1 Appliances and their surroundings shall not attain excessive temperatures in normal use.

Compliance is checked by determining the temperature rise of the various parts under the conditions specified in 11.2 to 11.7 but if the temperature rise of the motor winding exceeds the value specified in table 3 or if there is doubt with regard to the classification of the insulation system employed in a motor, by the tests of annex C.

11.2 *HAND-HELD APPLIANCES* are held in their normal position of use.

BUILT-IN APPLIANCES are installed in accordance with the instructions for installation.

Other *HEATING APPLIANCES* and other *COMBINED APPLIANCES* are placed in a test corner as follows:

- appliances normally placed on a floor or table in use, are placed on the floor as near to the walls as possible;
- appliances normally fixed to a wall are fixed on one of the walls, as near to the other wall and to the floor or ceiling as is likely to occur in normal use, unless otherwise stated in the instructions for installation;
- appliances normally fixed to a ceiling are fixed to the ceiling as near to the walls as is likely to occur in normal use, unless otherwise stated in the instructions for installation.

Other *MOTOR-OPERATED APPLIANCES* are positioned as follows:

- appliances normally placed on a floor or table in use, are placed on a horizontal support;
- appliances normally fixed to a wall are fixed to a vertical support;
- appliances normally fixed to a ceiling are fixed underneath a horizontal support.

Dull black-painted plywood approximately 20 mm thick is used for the test corner, the supports and for the installation of *BUILT-IN APPLIANCES*.

For appliances provided with an automatic cord reel, one-third of the total length of the cord is unreeled. The temperature rise of the cord sheath is determined as near as possible to the hub of the reel and also between the two outermost layers of the cord on the reel.

For cord storage devices other than automatic cord reels, which are intended to accommodate the *SUPPLY CORD* partially while the appliance is in operation, 50 cm of the cord is unwound. The temperature rise of the stored part of the cord is determined at the most unfavourable place.

11.3 *Temperature rises other than those of windings are determined by means of fine-wire thermocouples positioned so that they have minimum effect on the temperature of the part under test.*

NOTE 1 – Thermocouples having wires with a diameter not exceeding 0,3 mm are considered to be fine-wire thermocouples.

Thermocouples used for determining the temperature rise of the surface of walls, ceiling and floor are attached to the back of small blackened disks of copper or brass, 15 mm in diameter and 1 mm thick. The front of the disk is flush with the surface of the board.

So far as is possible, the appliance is positioned so that the thermocouples detect the highest temperatures.

The temperature rise of electrical insulation, other than that of windings, is determined on the surface of the insulation, at places where failure could cause a short circuit, contact between LIVE PARTS and accessible metal parts, bridging of insulation or reduction of CREEPAGE DISTANCES or CLEARANCES below the values specified in 29.1.

Temperature rises of windings are determined by the resistance method unless the windings are non-uniform or if it is difficult to make the necessary connections, in which case the temperature rise is determined by means of thermocouples.

NOTES

2 If it is necessary to dismantle the appliance to position thermocouples, care is taken to ensure that the appliance has been correctly reassembled and the power input is measured again.

3 The point of separation of the cores of a multicore cord and the point where insulated wires enter lampholders, are examples of places where thermocouples are positioned.

11.3DV D2 Modification of the first paragraph of 11.3 to add the following:

Measuring motor winding temperatures by thermocouples is not prohibited.

11.4 *HEATING APPLIANCES are operated under NORMAL OPERATION, at 1,15 times the RATED POWER INPUT.*

11.5 *MOTOR-OPERATED APPLIANCES are operated under NORMAL OPERATION, supplied with the most unfavourable voltage between 0,94 times and 1,06 times the RATED VOLTAGE.*

11.6 *COMBINED APPLIANCES are operated under NORMAL OPERATION, supplied with the most unfavourable voltage between 0,94 times and 1,06 times the RATED VOLTAGE.*

11.7 *The appliance is operated for a duration corresponding to the most unfavourable conditions of normal use.*

NOTE – The duration of the test may consist of more than one cycle of operation.

11.8 *During the test the temperature rises are monitored continuously and shall not exceed the values shown in table 3, PROTECTIVE DEVICES shall not operate and sealing compound shall not flow out.*

NOTES

1 The values in the table are based on an ambient temperature not normally exceeding 25°C but occasionally reaching 35°C. However, the temperature rise values specified are based on 25°C.

2 The temperature rise of a winding is calculated from the formula:

$$\Delta t = \frac{R_2 - R_1}{R_1} (k \cdot t_1) + (t_2 - t_1)$$

where

Δt is the temperature rise of the winding;

R_1 is the resistance at the beginning of the test;

R_2 is the resistance at the end of the test;

k is equal to 234,5 for copper windings and 225 for aluminum windings;

t_1 is the room temperature at the beginning of the test;

t_2 is the room temperature at the end of the test.

At the beginning of the test, the windings are to be at room temperature. It is recommended that the resistance of windings at the end of the test be determined by taking resistance measurements as soon as possible after switching off and then at short intervals so that a curve of resistance against time can be plotted for ascertaining the resistance at the instant of switching off.

3 The temperature rise limit for metal applies to parts having a metal coating at least 0,1 mm thick and to metal parts having a plastic coating less than 0,3 mm thick.

4 The temperature of the terminals of switches is measured if the switch is tested in accordance with annex S.

Table 3 – Maximum normal temperature rises

| <i>Part</i> | <i>Temperature rise K</i> |
|--|--|
| <i>Windings¹⁾, if the winding insulation according to IEC 60085 is:</i> <i>class A</i> <i>class E</i> <i>class B</i> <i>class F</i> <i>class H</i> <i>class 200</i> <i>class 220</i> <i>class 250</i> | 75 (65) 90 (80) 95 (85) 115 140 160 180 210 |
| <i>Pins of appliance inlets:</i> – for very hot conditions – for hot conditions – for cold conditions | 130 95 45 |
| <i>Terminals, including earthing terminals, for external conductors of STATIONARY APPLIANCES, unless they are provided with a SUPPLY CORD</i> | 60 |
| <i>Ambient of switches, THERMOSTATS and TEMPERATURE LIMITERS²⁾:</i> – without T-marking – with T-marking | 30 T-25 |
| <i>Rubber or polyvinyl chloride insulation of internal and external wiring including SUPPLY CORDS:</i> – without temperature rating ³⁾ – with temperature rating (T) | 50 T-25 |
| <i>Cord sheaths used as SUPPLEMENTARY INSULATION</i> | 35 |
| <i>Sliding contacts of cord reels</i> | 65 |

| | |
|---|---|
| <p><i>Rubber, other than synthetic, used for gaskets or other parts, the deterioration of which could affect safety:</i></p> <ul style="list-style-type: none"> – when used as SUPPLEMENTARY INSULATION or as REINFORCED INSULATION – in other cases | <p style="text-align: right;">40</p> <p style="text-align: right;">50</p> |
| <p><i>Lampholders with T – marking ⁹⁾:</i></p> <ul style="list-style-type: none"> – B15 and B22 marked T1 – B15 and B22 marked T2 – other lampholders | <p style="text-align: right;">140</p> <p style="text-align: right;">185</p> <p style="text-align: right;">T-25</p> |
| <p><i>Lampholders without T – marking ⁹⁾:</i></p> <ul style="list-style-type: none"> – E14 and B15 – B22, and E26 and E27 – other lampholders and starter holders for fluorescent lamps | <p style="text-align: right;">110</p> <p style="text-align: right;">140</p> <p style="text-align: right;">55</p> |
| <p><i>Material used as insulation other than that specified for wires and windings ⁴⁾</i></p> <ul style="list-style-type: none"> – impregnated or varnished textile, paper or press board – laminates bonded with: <ul style="list-style-type: none"> • melamine-formaldehyde, phenol-formaldehyde or phenol-furfural resins • urea-formaldehyde resin – printed circuit boards bonded with epoxy resin – Moulding of: <ul style="list-style-type: none"> • phenol-formaldehyde with cellulose fillers • phenol-formaldehyde with mineral fillers • melamine-formaldehyde • urea-formaldehyde – polyester with glass-fibre reinforcement – silicone rubber – polytetrafluoroethylene – pure mica and tightly sintered ceramic material when such materials are used as SUPPLEMENTARY INSULATION or REINFORCED INSULATION – thermoplastic material ⁵⁾ | <p style="text-align: right;">70</p> <p style="text-align: right;">85 (175)</p> <p style="text-align: right;">65 (150)</p> <p style="text-align: right;">120</p> <p style="text-align: right;">85 (175)</p> <p style="text-align: right;">100 (200)</p> <p style="text-align: right;">75 (150)</p> <p style="text-align: right;">65 (150)</p> <p style="text-align: right;">110</p> <p style="text-align: right;">145</p> <p style="text-align: right;">265</p> <p style="text-align: right;">400</p> <p style="text-align: right;">–</p> |
| <p><i>Wood, in general ⁶⁾</i></p> <ul style="list-style-type: none"> – wooden supports, walls, ceiling and floor of the test corner and wooden cabinets: <ul style="list-style-type: none"> • STATIONARY APPLIANCES liable to be operated continuously for long periods • other appliances | <p style="text-align: right;">65</p> <p style="text-align: right;">60</p> <p style="text-align: right;">65</p> |

| | |
|--|---|
| <p>Outer surface of capacitors⁷⁾:</p> <ul style="list-style-type: none"> – with marking of maximum operating temperature (T)⁸⁾ – without marking of maximum operating temperature: <ul style="list-style-type: none"> • small ceramic capacitors for radio and television interference suppression • capacitors complying with IEC 60384-14 • other capacitors | <p>T-25</p> <p>50</p> <p>50</p> <p>20</p> |
| <p>External enclosure of MOTOR-OPERATED APPLIANCES, except handles held in normal use</p> | <p>60</p> |
| <p>Handles, knobs, grips and similar parts which are continuously held in normal use (e.g. soldering irons):</p> <ul style="list-style-type: none"> – of metal – of porcelain or vitreous material – of moulded material, rubber or wood | <p>30</p> <p>40</p> <p>50</p> |
| <p>Handles, knobs, grips and similar parts which are held for short periods only in normal use (e.g. switches):</p> <ul style="list-style-type: none"> – of metal – of porcelain or vitreous material – of moulded material, rubber or wood | <p>35</p> <p>45</p> <p>60</p> |
| <p>Parts in contact with oil having a flash-point of t EC</p> | <p>$t-50$</p> |
| <p>Any point where the insulation of wires can come into contact with parts of a terminal block or compartment for fixed wiring of a STATIONARY APPLIANCE not provided with a SUPPLY CORD:</p> <ul style="list-style-type: none"> – when the instructions requires the use of supply wires with temperature rating (T) – in other cases³⁾ | <p>T-25</p> <p>50</p> |

Notes to table 3

1) To allow for the fact that the average temperature of windings of universal motors, relays, solenoids and similar components, is usually above the temperature at the points on the windings where thermocouples are placed, the figures without parentheses apply when the resistance method is used and those within parentheses apply when thermocouples are used. For windings of vibrator coils and a.c. motors, the figures without parentheses apply in both cases.

For motors constructed so that the circulation of air between the inside and the outside of the case is prevented but which are not necessarily sufficiently enclosed to be considered airtight, the temperature rise limits may be increased by 5 K.

2) *T* means the maximum ambient temperature in which the component or its switch head can operate.

The ambient is the temperature of the air at the hottest point at a distance of 5 mm from the surface of the component concerned.

However, if a thermostat or a temperature limiter is mounted on a heat-conducting part, the declared temperature limit of the mounting surface (*T_s*) is also applicable. Therefore, the temperature rise of the mounting surface has to be measured.

For the purpose of this test, switches and THERMOSTATS marked with individual ratings may be considered as having no marking for the maximum operating temperature, if requested by the appliance manufacturer.

3) This limit applies to cords and wires complying with the relevant IEC standards; for others it may be different.

4) The values in parentheses apply if the material is used for handles, knobs, grips and similar parts and is in contact with hot metal.

5) There is no specific limit for thermoplastic material. However the temperature rise has to be determined in order that the tests of 30.1 can be carried out.

6) The limit specified concerns the deterioration of wood and it does not take into account deterioration of surface finishes.

7) There is no limit for the temperature rise of capacitors which are short-circuited in 19.11.

8) Temperature marking for capacitors mounted on printed circuit boards may be given in the technical sheet.

9) Locations for measuring the temperature rises are specified in table 12.1 of IEC 60598-1.

If these or other materials are used, they shall not be subjected to temperatures in excess of the thermal capabilities as determined by aging tests made on the materials themselves.

11.8DV DC Deletion of note in table 3:**Delete note 4 to table 3**

12 Void

13 Leakage current and electric strength at operating temperature

13.1 At operating temperature, the leakage current of the appliance shall not be excessive and its electric strength shall be adequate.

Compliance is checked by the tests of 13.2 and 13.3.

The appliance is operated under NORMAL OPERATION for the duration specified in 11.7.

HEATING APPLIANCES are operated at 1,15 times the RATED POWER INPUT.

MOTOR-OPERATED APPLIANCES and COMBINED APPLIANCES are supplied at 1,06 times the RATED VOLTAGE.

Three-phase appliances which, according to the instructions for installation, are also suitable for single-phase supply are tested as single-phase appliances with the three circuits connected in parallel.

PROTECTIVE IMPEDANCE and radio interference filters are disconnected before carrying out the tests.

13.2 *The leakage current is measured by means of the circuit described in annex G, between any pole of the supply and accessible metal parts connected to metal foil having an area not exceeding 20 cm x 10 cm which is in contact with accessible surfaces of insulating materials.*

For single-phase appliances, the measuring circuit is shown in the following figures:

- if of CLASS II, figure 4;*
- if other than CLASS II, figure 5.*

The leakage current is measured with the selector switch in each of the positions 1 and 2.

For three-phase appliances, the measuring circuit is shown in the following figures:

- if of CLASS II, figure 6;*
- if other than CLASS II, figure 7.*

For three-phase appliances, the leakage current is measured with the switches a, b and c in the closed position. The measurements are then repeated with each of the switches a, b and c open in turn, the other two switches remaining closed. For appliances intended to be connected in star connection only, the neutral is not connected.

After the appliance has been operated for a duration as specified in 11.7, the leakage current shall not exceed the following values:

| | |
|--|--|
| – for CLASS 0, CLASS 0I AND CLASS III APPLIANCES | 0,5 mA |
| – for portable CLASS I APPLIANCES | 0,75 mA |
| – for stationary CLASS I MOTOR-OPERATED APPLIANCES | 3,5 mA |
| – for STATIONARY CLASS I HEATING APPLIANCES | 0,75 mA or 0,75 mA per kW RATED POWER input of the appliance, whichever is the greater, with a maximum of 5 mA. |
| – for CLASS II APPLIANCES | 0,25 mA |

For COMBINED APPLIANCES the total leakage current may be within the limits specified for HEATING APPLIANCES or for MOTOR-OPERATED APPLIANCES, whichever is the greater, but the two limits are not added.

If the appliance incorporates capacitors and is provided with a single-pole switch, the measurements are repeated with the switch in the OFF POSITION.

If the appliance incorporates a thermal control which operates during the test of clause 11, the leakage current is measured immediately before the control opens the circuit.

NOTES

- 1 The test with the switch in the OFF POSITION is made to verify that capacitors connected behind a single-pole switch do not cause an excessive leakage current.
- 2 It is recommended that the appliance is applied through an isolating transformer; otherwise it is to be insulated from earth.
- 3 The metal foil has the largest area possible on the surface under test without exceeding the dimensions specified. If its area is smaller than the surface under test, it is moved to test all parts of the surface.

The heat dissipation of the appliance is not to be affected by the metal foil.

13.2DV D1 Replacement:

Replace subclause 13.2 with the requirements in Annex DVE.

13.3 The insulation is subjected for 1 min to a voltage of substantially sinusoidal waveform and having a frequency of 50 Hz or 60 Hz. For single-phase appliances, the connections are shown in figure 8. Motors and three-phase appliances are tested immediately after the appliance has been disconnected from the supply.

The test voltage is applied between LIVE PARTS and ACCESSIBLE PARTS, non-metallic parts being covered with metal foil. For CLASS II CONSTRUCTIONS having intermediate metal between LIVE PARTS and ACCESSIBLE PARTS, the voltage is applied across the BASIC INSULATION and the SUPPLEMENTARY INSULATION.

The value of the test voltage is

- 500 V for BASIC INSULATION subjected in normal use to SAFETY EXTRA-LOW VOLTAGE;
- 1 000 V for other BASIC INSULATION;
- 2 750 V for SUPPLEMENTARY INSULATION;
- 3 750 V for REINFORCED INSULATION.

Initially, not more than half the prescribed voltage is applied, then it is raised gradually to the full value.

No breakdown shall occur during the test.

NOTES

- 1 Glow discharges without drop in voltage are neglected.
- 2 The high-voltage source used for the test is to be capable of supplying a short circuit current I_s between the output terminals after the output voltage has been adjusted to the appropriate test voltage U . The overload release of the circuit is not to operate for any current below the tripping current I_r . The voltmeter used to measure the r.m.s. value of the test voltage is to be at least of class 2.5 according to IEC 60051-2. The values of I_s and I_r are given in table 4 for various high voltage sources.
- 3 If the secondary winding of the isolating transformer is not provided with a tap at the midpoint, the output winding of the high-voltage transformer can be connected to the midpoint of a potentiometer having a total resistance not exceeding 2 000 Ω and connected across the output winding of the isolating transformer.
- 4 Care should be taken to avoid overstressing the components of ELECTRONIC CIRCUITS.

Table 4 – Characteristic of high-voltage sources

| Test voltage U V | Minimum current mA | |
|---------------------------|-----------------------|-------|
| | I_s | I_r |
| $U < 4\ 000$ | 200 | 100 |
| $4\ 000 \# U < 10\ 000$ | 80 | 40 |
| $10\ 000 \# U \# 20\ 000$ | 40 | 20 |

1) The currents are calculated on the basis of short circuit and release energies of 800 VA and 400 VA respectively at the upper end of the voltage ranges.

2) The measurement uncertainty of the high voltage shall not exceed $\pm 3\%$ of the measured voltage for a leakage current up to 50% of I_r .

14 Void

15 Moisture resistance

15.1 The enclosure of the appliance shall provide the degree of protection against moisture in accordance with the classification of the appliance.

Compliance is checked as specified in 15.1.1 taking into account 15.1.2, the appliance not being connected to the supply.

The appliance then shall withstand the electric strength test of 16.3 and inspection shall show that there is no trace of water on insulation which could result in a reduction of CREEPAGE DISTANCES and CLEARANCES below the values specified in 29.1.

NOTE – The external enclosure is carefully wiped to remove any surplus water before inspection. Care has to be taken when dismantling to avoid displacing any water within the appliance.

15.1.1 *Appliances other than IPX0, are subjected to the tests of IEC 60529 as follows:*

- IPX1 appliances as described in subclause 14.2.1;*
- IPX2 appliances as described in subclause 14.2.2;*
- IPX3 appliances as described in subclause 14.2.3a;*
- IPX4 appliances as described in subclause 14.2.4a;*
- IPX5 appliances as described in subclause 14.2.5;*
- IPX6 appliances as described in subclause 14.2.6;*
- IPX7 appliances as described in subclause 14.2.7.*

For this test the appliance is immersed in water containing approximately 1% NaCl.

NOTE – The hand-held spray nozzle may be used for testing appliances which cannot be placed under the oscillating tube specified in IEC 60529.

15.1.2 *HAND-HELD APPLIANCES are turned continuously through the most unfavourable positions during the test.*

BUILT-IN APPLIANCES are installed in accordance with the instructions.

Appliances normally used on the floor or table are placed on a horizontal unperforated support having a diameter of twice the oscillating tube radius minus 15 cm.

Appliances normally fixed to a wall are mounted as in normal use in the centre of a wooden board having dimensions which are 15 cm \pm 5 cm in excess of those of the orthogonal projection of the appliance on the board. The wooden board is placed at the centre of the oscillating tube.

For IPX3, the base of wall-mounted appliances is placed at the same level as the pivot axis of the oscillating tube.

For IPX4, the horizontal centre line of the appliance is aligned with the pivot axis of the oscillating tube. However, for appliances normally used on the floor or table, the movement is limited to two times 90E from the vertical for a period of 5 min, the support being placed at the level of the pivot axis of the oscillating tube.

If, for wall-mounted appliances, the instructions for installation state that the appliance is to be placed close to the floor level and specifies a distance, a board is placed under the appliance at that distance. The dimensions of the board are 15 cm more than the horizontal projection of the appliance.

Appliances with TYPE X ATTACHMENTS, except those having a specially prepared cord, are fitted with the lightest permissible type of flexible cord of the smallest cross-sectional area specified in table 11.

DETACHABLE PARTS are removed and subjected, if necessary, to the relevant treatment with the main part. However, if the instructions state that a part has to be removed for USER MAINTENANCE and a TOOL is needed, this part is not removed.

15.2 Appliances subject to spillage of liquid in normal use shall be constructed so that such spillage does not affect their electrical insulation.

Compliance is checked by the following test.

Appliances with TYPE X ATTACHMENT, except those having a specially prepared cord, are fitted with the lightest permissible type of flexible cord of the smallest cross-sectional area specified in table 11.

Appliances incorporating an appliance inlet are tested with or without an appropriate connector in position, whichever is most unfavourable.

DETACHABLE PARTS are removed.

The liquid container of the appliance is completely filled with water containing approximately 1% NaCl and a further quantity, equal to 15% of the capacity of the container or 0,25 l, whichever is the greater, is poured in steadily over a period of 1 min.

The appliance shall then withstand the electric strength test of 16.3 and inspection shall show that there is no trace of water on insulation which could result in a reduction of CREEPAGE DISTANCES and CLEARANCES below the values specified in 29.1.

15.3 Appliances shall be proof against humid conditions which may occur in normal use.

Compliance is checked by the following humidity treatment.

Appliances subjected to the test of 15.1 or 15.2 are kept in a test room having a normal atmosphere for 24 h before being subjected to the test.

Cable entries, if any, are left open; if knock-outs are provided, one of them is opened.

DETACHABLE PARTS are removed and subjected, if necessary, to the humidity test with the main part.

The humidity test is carried out for 48 h in a humidity cabinet containing air with a relative humidity of $(93 \pm 3)\%$. The temperature of the air is maintained within 1 K of any convenient value t between 20EC and 30EC. Before being placed in the humidity cabinet, the appliance is brought to a temperature of t^{+4}_0 EC.

The appliance shall then withstand the tests of clause 16 in the humidity cabinet or in the room in which the appliance was brought to the prescribed temperature after reassembly of those parts which may have been removed.

NOTES

1 In most cases, the appliance may be brought to the specified temperature by keeping it at this temperature for at least 4 h before the humidity test.

2 A relative humidity of $(93 \pm 3)\%$ can be obtained by placing, in the humidity cabinet, a saturated solution of Na_2SO_4 or KNO_3 in water, the container having a sufficient large contact surface with the air.

3 The specified conditions may be achieved by ensuring a constant circulation of the air within a thermally insulated cabinet.

16 Leakage current and electric strength

16.1 The leakage current of the appliance shall not be excessive and its electric strength shall be adequate.

Compliance is checked by the tests of 16.2 and 16.3.

PROTECTIVE IMPEDANCE is disconnected from LIVE PARTS before carrying out the tests.

The tests are made on the appliance at room temperature and not connected to the supply.

16.2 An a.c. test voltage is applied to items 1 and 3 specified in table 5, the metal foil having a size not exceeding 20 cm x 10 cm and being moved, if necessary, so that all parts of the surface are tested.

The test voltage is

- 1,06 times RATED VOLTAGE for single-phase appliances,
- 1,06 times RATED VOLTAGE, divided by $\sqrt{3}$, for three-phase appliances.

The leakage current is measured within 5 s after the application of the test voltage.

The leakage current shall not exceed the following values:

| | |
|--|---|
| – for CLASS 0, CLASS 0I AND CLASS III APPLIANCES | 0,5 mA |
| – for PORTABLE CLASS I APPLIANCES | 0,75 mA |
| – for STATIONARY CLASS I MOTOR-OPERATED APPLIANCES | 3,5 mA |
| – for STATIONARY CLASS I HEATING APPLIANCES | 0,75 mA or 0,75 mA per kW RATED POWER INPUT of the appliance, whichever is the greater, with a maximum of 5 mA |
| – for CLASS II APPLIANCES | 0,25 mA |

The values specified above are doubled if all controls have an OFF POSITION in all poles. They are also doubled if

- the appliance has no control other than a THERMAL CUT-OUT or
- all THERMOSTATS, TEMPERATURE LIMITERS and energy regulators do not have an OFF POSITION, or
- the appliance has radio interference filters. In this case the leakage current with the filter disconnected shall not exceed the limits specified.

For COMBINED APPLIANCES the total leakage current may be within the limits specified for HEATING APPLIANCES or for MOTOR-OPERATED APPLIANCES, whichever is the greater, but the two limits are not added.

16.2DV D1 Replacement:

Replace subclause 16.2 with the requirements in Annex DVE.

16.3 Immediately after the test of 16.2 the insulation is subjected for 1 min to a voltage of substantially sinusoidal waveform and having a frequency of 50 Hz or 60 Hz. The value of the test voltage and the points of application are shown in table 5.

ACCESSIBLE PARTS of insulating material are covered with metal foil.

The value of 1 250 V is reduced to 1 000 V for appliances with a RATED VOLTAGE not exceeding 130 V.

Initially, not more than half the prescribed voltage is applied, then it is raised gradually to the full value.

No breakdown shall occur during the test.

NOTES

- 1 Care is taken that the metal foil is placed so that no flashover occurs at the edges of the insulation.
- 2 The high-voltage source used for the test is described in note 2 of 13.3.
- 3 For CLASS II CONSTRUCTION incorporating both REINFORCED INSULATION and DOUBLE INSULATION, care is taken that the voltage applied to the REINFORCED INSULATION does not overstress the BASIC INSULATION or the SUPPLEMENTARY INSULATION.
- 4 In constructions where BASIC INSULATION and SUPPLEMENTARY INSULATION cannot be tested separately, the insulation provided is subjected to the test voltages specified for REINFORCED INSULATION.
- 5 When testing insulating coatings, the metal foil may be pressed against the insulation by means of a sandbag so that the pressure is approximately 5 kPa. The test may be limited to places where the insulation is likely to be weak, for example where there are sharp metal edges under the insulation.
- 6 If practicable, insulating linings are tested separately.
- 7 Care is taken to avoid overstressing the components of ELECTRONIC CIRCUITS.

Table 5 – test voltages

| Points of application | Test voltage V | | |
|--|--|--|------------------|
| | CLASS III APPLIANCES and CLASS III CONSTRUCTIONS | CLASS II APPLIANCES and CLASS II CONSTRUCTIONS | Other appliances |
| 1. Between LIVE PARTS and ACCESSIBLE PARTS separated from LIVE PARTS by –BASIC INSULATION only –REINFORCED INSULATION | 500 – | – 3 750 | 1 250 3 750 |
| 2. For parts with DOUBLE INSULATION, between metal parts separated from LIVE PARTS by BASIC INSULATION only and –LIVE PARTS –ACCESSIBLE PARTS | – – | 1 250 2 500 | 1 250 2 500 |
| 3. Between metal enclosures or covers lined with insulating material and metal foil in contact with the inner surface of the lining, if the distance between LIVE PARTS and these metal enclosures or covers, measured through the lining, is less than the appropriate CLEARANCE as specified in 29.1 | – | 2 500 | 1 250 |
| 4. Between metal foil in contact with handles, knobs, grips and similar parts and their shafts, if these shafts can become live in the event of an insulation fault ¹⁾ | – | 2 500 | 2 500 (1 250) |
| 5. Between ACCESSIBLE PARTS and the SUPPLY CORD wrapped with metal foil, where the cord is fitted in inlet bushings of insulating material, cord guards, cord anchorages and similar parts ^{2), 3)} | – | 2 500 | 1 250 |
| 6. Between the point where a winding and a capacitor are connected together, if a resonance voltage U occurs between this point and any terminal for external conductors, and –ACCESSIBLE PARTS –metal parts separated from LIVE PARTS by BASIC INSULATION only ⁴⁾ | – – | – 2 U + 1 000 | 2 U + 1 000 |
| 1) The value in parentheses applies to CLASS 0 APPLIANCES. 2) The outer surface of the cord guard is not wrapped with the metal foil. 3) The torque applied to clamping screws of the cord anchorages is 2/3 of the torque specified in 28.1. 4) The test between the point where a winding and a capacitor are connected together and ACCESSIBLE PARTS or metal parts is only made where the insulation is subjected to the resonance voltage under NORMAL OPERATION. Other parts are disconnected and the capacitor is short-circuited. | | | |

17 Overload protection of transformers and associated circuits

Appliances incorporating circuits supplied from a transformer shall be constructed so that in the event of short circuits which are likely to occur in normal use, excessive temperatures do not occur in the transformer or in the circuits associated with the transformer.

Compliance is checked by applying the most unfavourable short circuit or overload which is likely to occur in normal use, the appliance being supplied with 1,06 times or 0,94 times RATED VOLTAGE, whichever is the more unfavourable.

The temperature rise of the insulation of the conductors of SAFETY EXTRA-LOW VOLTAGE circuits shall not exceed the relevant value specified in table 3 by more than 15 K.

The temperature of the windings shall not exceed the values specified in table 6. However, these limits do not apply to fail-safe transformers complying with subclause 15.5 of IEC 61558-1.

NOTES

- 1 Examples of short circuits which are likely to occur in normal use are the short-circuiting of bare or inadequately insulated conductors of SAFETY EXTRA-LOW VOLTAGE circuits which are accessible.
- 2 Failure of BASIC INSULATION is not considered likely to occur in normal use.
- 3 Protection of transformer windings may be obtained by the inherent impedance of the winding or by means of fuses, automatic controls, THERMAL CUT-OUTS or similar devices incorporated in the transformer or located inside the appliance, provided these devices are only accessible with the aid of a TOOL.

18 Endurance

Requirements and tests are specified in part 2 where necessary.

19 Abnormal operation

19.1 Appliances shall be constructed so that the risk of fire, mechanical damage impairing safety or protection against electric shock as a result of abnormal or careless operation, is obviated as far as is practicable.

ELECTRONIC CIRCUITS shall be designed and applied so that a fault condition will not render the appliance unsafe with regard to electric shock, fire hazard, mechanical hazard or dangerous malfunction.

Appliances incorporating heating elements are subjected to the tests of 19.2 and 19.3. In addition, such appliances provided with a control limiting the temperature during clause 11 are subjected to the tests of 19.4 and where applicable to the test of 19.5. Appliances incorporating PTC HEATING ELEMENTS are also subjected to the test of 19.6.

Appliances incorporating motors are subjected to the tests of 19.7 to 19.10 as applicable.

Appliances incorporating ELECTRONIC CIRCUITS are also subjected to the tests of 19.11 and 19.12 as applicable.

Unless otherwise specified, the tests are continued until a NON-SELF-RESETTING THERMAL CUT-OUT operates or until steady conditions are established. If a heating element or an intentionally weak part becomes permanently open-circuited, the relevant test is repeated on a second sample. This second test shall be terminated in the same mode unless the test is otherwise satisfactorily completed.

Only one abnormal condition is simulated each time.

Unless otherwise specified, compliance with the tests of this clause is checked as described in 19.13.

NOTES

1 An intentionally weak part is a part intended to rupture under conditions of abnormal operation to prevent the occurrence of a condition which could impair compliance with this standard. Such a part may be a replaceable component, such as a resistor or a capacitor or a part of a component to be replaced, such as an inaccessible THERMAL LINK incorporated in a motor.

2 Fuses, THERMAL CUT-OUTS, overcurrent protection devices or similar devices, incorporated in the appliance, may be used to provide the necessary protection. The PROTECTIVE DEVICE in the fixed wiring does not provide the necessary protection.

3 If more than one of the tests are applicable to the same appliance, these tests are made consecutively after the appliance has cooled down to room temperature.

4 For COMBINED APPLIANCES, the tests are carried out with motors and heating elements operating simultaneously under conditions of NORMAL OPERATION, the appropriate tests being applied one at a time to each motor and heating element.

5 When it is stated that a control is short-circuited, it may be rendered inoperative instead.

19.2 *Appliances with heating elements are tested under the conditions specified in clause 11 but with restricted heat dissipation. The supply voltage, determined prior to the test, is that required to provide a power input of 0,85 times RATED POWER INPUT under NORMAL OPERATION when the power input has stabilized. This voltage is maintained throughout the test.*

19.3 *The test of 19.2 is repeated but with a supply voltage, determined prior to the test, equal to that required to provide a power input of 1,24 times RATED POWER INPUT under NORMAL OPERATION when the power input has stabilized. This voltage is maintained throughout the test.*

19.4 *The appliance is tested under the conditions specified in clause 11, the power input being 1,15 times RATED POWER INPUT. Any control which limits the temperature during the test of clause 11 is short-circuited.*

NOTE – If the appliance is provided with more than one control, these are short-circuited in turn.

19.5 *The test of 19.4 is repeated on CLASS 0/APPLIANCES and CLASS I/APPLIANCES incorporating tubular sheathed or embedded heating elements. However, controls are not short-circuited but one end of the element is connected to the sheath of the heating element.*

This test is repeated with the polarity of the supply to the appliance reversed and with the other end of the element connected to the sheath.

The test is not carried out on appliances intended to be permanently connected to fixed wiring and on appliances where an ALL-POLE DISCONNECTION occurs during the test of 19.4.

NOTES

- 1 Appliances with a neutral are tested with the neutral connected to the sheath.
- 2 For embedded heating elements, the metal enclosure is considered to be the sheath.

19.6 *Appliances with PTC HEATING ELEMENTS are supplied at RATED VOLTAGE until steady conditions with regard to power input and temperature are established.*

The WORKING VOLTAGE of the PTC HEATING ELEMENT is increased by 5% and the appliance is operated until steady conditions are re-established. The voltage is then increased in similar steps until 1,5 times WORKING VOLTAGE is reached or until the PTC HEATING ELEMENTS ruptures, whichever occurs first.

19.7 *The appliance is operated under stalled conditions by*

- *locking the rotor if the locked rotor torque is smaller than the full load torque;*
- *locking moving parts of other appliances.*

NOTES

- 1 If an appliance has more than one motor, the test is made for each motor separately.
- 2 Alternative tests for protected motor units are given in annex D.

Appliances incorporating motors and having capacitors in the circuit of an auxiliary winding, are operated with the rotor locked, the capacitors being open-circuited one at a time. The test is repeated with the capacitors short-circuited one at a time unless they are of class P2 of IEC 60252.

NOTE 3 – *This test is made with the rotor locked because certain motors with capacitors may or may not start so that variable results could be obtained.*

For each of the tests, appliances provided with a timer or programmer are supplied at RATED VOLTAGE for a period equal to the maximum period allowed by the timer or programmer.

Other appliances are supplied at RATED VOLTAGE for a period

– *of 30 s for:*

- *HAND-HELD APPLIANCES;*
- *appliances which have to be kept switched on by hand or foot;*

- *appliances which are continuously loaded by hand;*
- *of 5 min for other appliances operated while attended;*
- *until steady conditions are established for the other appliances.*

NOTE 4 – Appliances which are tested for 5 min are indicated in the relevant part 2.

During the test, the temperature of the windings shall not exceed the values shown in table 6.

Table 6 – Maximum winding temperature

| Type of appliance | Temperature EC | | | | | | | |
|--|-------------------|---------|---------|---------|---------|-----------|-----------|-----------|
| | Class A | Class E | Class B | Class F | Class H | Class 200 | Class 220 | Class 250 |
| Appliances other than those operated until steady conditions are established | 200 | 215 | 225 | 240 | 260 | 280 | 300 | 330 |
| Appliances operated until steady conditions are established | | | | | | | | |
| – if impedance protected | 150 | 165 | 175 | 190 | 210 | 230 | 250 | 280 |
| – if protected by PROTECTIVE DEVICES | | | | | | | | |
| • during the first hour, maximum value | 200 | 215 | 225 | 240 | 260 | 280 | 300 | 330 |
| • after first hour, maximum value | 175 | 190 | 200 | 215 | 235 | 255 | 275 | 305 |
| • after first hour, arithmetic average | 150 | 165 | 175 | 190 | 210 | 230 | 250 | 280 |

19.8 One phase of appliances incorporating three-phase motors is disconnected. The appliance is then operated under NORMAL OPERATION and supplied at RATED VOLTAGE for the period specified in 19.7.

19.9 A running overload test is made on appliances incorporating motors which are either intended to be remotely or automatically controlled or liable to be operated continuously.

The appliance is operated under NORMAL OPERATION and supplied at RATED VOLTAGE until steady conditions are established. The load is then increased so that the current through the motor windings is raised by 10% and the appliance is operated again until steady conditions are established, the supply voltage being maintained at its original value. The load is again increased and the test is repeated until the PROTECTIVE DEVICE operates or the motor stalls.

During the test the winding temperature shall not exceed

- 140EC for class A;
- 155EC for class E;
- 165EC for class B;
- 180EC for class F;
- 200EC for class H;
- 220EC for class 200;
- 240EC for class 220;
- 270EC for class 250.

NOTES

1 If the load cannot be increased in appropriate steps, the motor is removed from the appliance and tested separately.

2 Alternative tests for protected motor units are given in annex D.

19.10 *Appliances incorporating series motors are operated with the lowest possible load and supplied at 1,3 times RATED VOLTAGE for 1 min.*

During the test, parts shall not be ejected from the appliance.

19.11 *Compliance for ELECTRONIC CIRCUITS is checked by evaluation of the fault conditions specified in 19.11.2 for all circuits or parts of circuits, unless they comply with the conditions specified in 19.11.1.*

If the safety of the appliance under any of the fault conditions depends on the operation of a miniature fuse-link complying with IEC 60127, the test of 19.12 is made.

During and after each test, the temperature of the windings shall not exceed the values specified in table 6. However, these limits do not apply to fail-safe transformers complying with subclause 15.5 of IEC 61558-1. The appliance shall comply with the conditions specified in 19.13. Any current flowing through PROTECTIVE IMPEDANCE shall not exceed the limits specified in 8.1.4.

If a conductor of a printed circuit board becomes open-circuited, the appliance is considered to have withstood the particular test, provided all three of the following conditions are met:

- the material of the printed circuit board withstands the burning test of subclause 20.1 of IEC 60065;*
- any loosened conductor does not reduce the CREEPAGE DISTANCES or CLEARANCES between LIVE PARTS and accessible metal parts below the values specified in clause 29;*
- the appliance withstands the tests of 19.11.2 with the open-circuited conductor bridged.*

NOTES

1 Unless it is necessary to replace components after any of the tests, the electric strength test of 19.13 need only be carried out after the final test on the ELECTRONIC CIRCUIT.

2 In general, examination of the appliance and its circuit diagram will reveal the fault conditions which have to be simulated, so that testing can be limited to those cases which may be expected to give the most unfavourable results.

19.11.1 *Fault conditions a) to f) specified in 19.11.2 are not applied to circuits or parts of circuits where both of the following conditions are met:*

- the ELECTRONIC CIRCUIT is a low-power circuit as described below;*
- the protection against electric shock, fire hazard, mechanical hazard or dangerous malfunction in other parts of the appliance does not rely on the correct functioning of the ELECTRONIC CIRCUIT.*

A low-power circuit is determined as follows; an example is shown in figure 9.

The appliance is supplied at RATED VOLTAGE and a variable resistor adjusted to its maximum resistance is connected between the point to be investigated and the opposite pole of the supply source.

The resistance is then decreased until the power consumed by the resistor reaches a maximum. Points closest to the supply at which the maximum power delivered to this resistor does not exceed 15 W at the end of 5 s are called low-power points. The part of the circuit farther from the supply source than a low-power point is considered to be a low-power circuit.

NOTES

- 1 The measurements are made from only one pole of the supply source, preferably the one that gives the fewest low-power points.**
- 2 When determining the low-power points, it is recommended to start with points close to the supply source.**
- 3 The power consumed by the variable resistor is measured by a wattmeter.**

19.11.2 *The following fault conditions are considered and, if necessary, applied one at a time. Consequential faults are taken into consideration.*

- a) Short circuit of CREEPAGE DISTANCES and CLEARANCES between LIVE PARTS of different potential, if these distances are less than the values specified in 29.1, unless the relevant part is adequately encapsulated.*
- b) Open circuit at the terminals of any component.*
- c) Short circuit of capacitors, unless they comply with IEC 60384-14.*
- d) Short circuit of any two terminals of an ELECTRONIC COMPONENT, other than integrated circuits. This fault condition is not applied between the two circuits of an optocoupler.*
- e) Failure of triacs in the diode mode.*
- f) Failure of an integrated circuit. In this case the possible hazardous situations of the appliance are assessed to ensure that safety does not rely on the correct functioning of such a component.*

All possible output signals are considered under fault conditions within the integrated circuit. If it can be shown that a particular output signal is unlikely to occur, then the relevant fault is not considered.

NOTES

1 Components such as thyristors and triacs are not subjected to fault condition f).

2 Microprocessors are tested as integrated circuits.

In addition, each low-power circuit is short-circuited by connecting the low-power point to the pole of the supply from which the measurements were made.

For simulation of the fault conditions, the appliance is operated under the conditions specified in clause 11 but supplied at RATED VOLTAGE.

When any of the fault conditions are simulated, the duration of the test is

- as specified in 11.7 but only for one operating cycle and only if the fault cannot be recognized by the user, for example, change in temperature;*
- as specified in 19.7, if the fault can be recognized by the user, for example, when the motor of a kitchen machine stops;*
- until steady conditions are established, for circuits continuously connected to the supply mains, for example, stand-by circuits.*

In each case, the test is ended if interruption of the supply occurs within the appliance.

If the appliance incorporates an electronic circuit which operates to ensure compliance with clause 19, the relevant test is repeated with a single fault simulated, as indicated in a) to f) above.

Fault condition f) is applied to encapsulated and similar components if the circuit cannot be assessed by other methods.

Positive temperature coefficient resistors (PTC's), negative temperature coefficient resistors (NTC's) and voltage dependent resistors (VDR's) are not short-circuited if they are used within their manufacturer's declared specification.

19.12 If, for any of the fault conditions specified in 19.11.2, the safety of the appliance depends on the operation of a miniature fuse-link complying with IEC 60127, the test is repeated but with the miniature fuse-link replaced by an ammeter.

If the current measured does not exceed 2,1 times the RATED CURRENT of the fuse-link, the circuit is not considered to be adequately protected and the test is carried out with the fuse-link short-circuited.

If the current measured is at least 2,75 times the RATED CURRENT of the fuse-link, the circuit is considered to be adequately protected.

If the current measured exceeds 2,1 times the RATED CURRENT of the fuse-link but does not exceed 2,75 times the RATED CURRENT, the fuse link is short-circuited and the test is carried out

- for quick acting fuse-links, for the relevant period or for 30 min, whichever is the shorter;*
- for time lag fuse-links, for the relevant period or for 2 min, whichever is the shorter.*

NOTES

1 In case of doubt, the maximum resistance of the fuse-link has to be taken into account when determining the current.

2 The verification whether the fuse-link acts as a PROTECTIVE DEVICE is based on the fusing characteristics specified in IEC 127, which also gives the information necessary to calculate the maximum resistance of the fuse-link.

3 Other fuses are considered to be intentionally weak parts in accordance with 19.1.

19.13 During the tests the appliance shall not emit flames, molten metal, poisonous or ignitable gas in hazardous amounts and temperature rises shall not exceed the values shown in table 7.

After the tests and when the appliance has cooled to approximately room temperature, enclosures shall not have deformed to such an extent that compliance with clause 8 is impaired and, if the appliance can still be operated, it shall comply with 20.2.

After the tests, the insulation other than that of CLASS III APPLIANCES, when it has cooled down to approximately room temperature, shall withstand the electric strength test in 16.3, the test voltage however being

- 1 000 V for BASIC INSULATION;
- 2 750 V for SUPPLEMENTARY INSULATION;
- 3 750 V for REINFORCED INSULATION.

For appliances which are immersed in or filled with conducting liquid in normal use, the appliance is immersed in or filled with water for 24 h before the electric strength test is made.

NOTE – The humidity treatment of 15.3 is not applied before this electric strength test.

Table 7 – Maximum abnormal temperature rise

| Part | Temperature rise K |
|---|---|
| Wooden supports, walls, ceiling and floor of the test corner and wooden cabinets ¹⁾ | 150 |
| Insulation of the SUPPLY CORD ¹⁾ | 150 |
| SUPPLEMENTARY INSULATION and REINFORCED INSULATION other than thermoplastic materials ³⁾ | 1,5 times the relevant value specified in table 3 ²⁾ |
| Notes to table 7 | |
| 1) For motor-operated appliances these temperature rises are not determined. | |
| 2) This value is under consideration. | |
| 3) There is no specific limit for SUPPLEMENTARY INSULATION and REINFORCED INSULATION of thermoplastic material. However, the temperature rise has to be determined so that the test of 30.1 can be carried out. | |

20 Stability and mechanical hazards

20.1 Appliances, other than FIXED APPLIANCES and HAND-HELD APPLIANCES, intended to be used on a surface such as the floor or a table shall have adequate stability.

Compliance is checked by the following test, appliances incorporating an appliance inlet being fitted with an appropriate connector and flexible cord.

The appliance is placed in any normal position of use on a plane inclined at an angle of 10E to the horizontal, the SUPPLY CORD resting on the inclined plane in the most unfavourable position. However, if part of an appliance comes into contact with the horizontal supporting surface when the appliance is tilted through an angle of 10E, the appliance is placed on a horizontal support and tilted in the most unfavourable direction through an angle of 10E

NOTES

- 1 The appliance is not connected to the supply.
- 2 The test on the horizontal support may be necessary for appliances provided with rollers, castors or feet.

Appliances provided with doors are tested with the doors open or closed, whichever is the more unfavourable.

Appliances intended to be filled with liquid by the user in normal use are tested empty or filled with the most unfavourable quantity of water up to the capacity indicated in the instructions for use.

The appliance shall not overturn.

The test is repeated on appliances with heating elements with the angle of inclination increased to 15E. If the appliance overturns in one or more positions, it is subjected to the tests of clause 11 in each of these overturned positions.

During this test, temperature rises shall not exceed the values shown in table 7.

NOTE 3 – Castors or wheels are blocked to prevent the appliance from rolling.

20.2 Moving parts of appliances shall, as far as is compatible with the use and working of the appliance, be positioned or enclosed to provide adequate protection against personal injury in normal use.

Protective enclosures, guards and similar parts shall be NON-DETACHABLE PARTS and shall have adequate mechanical strength.

The unexpected reclosure of SELF-RESETTING THERMAL CUT-OUTS and overcurrent PROTECTIVE DEVICES shall not cause a hazard.

Compliance is checked by inspection, by the tests of clause 21 and by applying a force not exceeding 5 N by means of a test finger similar to that shown in figure 1 but having a circular stop face with a diameter of 50 mm, instead of the non-circular face.

For appliances provided with movable devices such as those intended for varying the tension of belts, the test with the test finger is made with these devices adjusted to the most unfavourable position within their range of adjustment; if necessary, belts are removed.

It shall not be possible to touch dangerous moving parts with this test finger.

NOTES

- 1 For some appliances complete protection is impracticable, for example sewing machines, food mixers and electric knives.
- 2 Examples of appliances in which SELF-RESETTING THERMAL CUT-OUTS and overcurrent PROTECTIVE DEVICES could cause a hazard are food mixers and wringers.
- 3 Enclosures which can be opened by overriding an interlock by applying the test finger are considered to be DETACHABLE PARTS.

20.2DV D1 Add the following after the fourth paragraph:

The articulate probe of figure 1DV shall replace the test finger of figure 1 when the product is:

- a) a hand-held product,
- b) a hand-held part of a product,
- c) used by children,
- d) accessible to children while the product is operating, or
- e) one that has special concerns for the accessibility of LIVE PARTS or mechanical hazards.

21 Mechanical strength

21.1 Appliances shall have adequate mechanical strength and be constructed to withstand such rough handling that may be expected in normal use.

Compliance is checked by applying blows to the appliance by means of the spring hammer as specified in IEC 60068-2-75.

The appliance is rigidly supported and three blows are applied to every point of the enclosure that is likely to be weak with an impact energy of $0,5 J \pm 0,04 J$.

If necessary, the blows are also applied to handles, levers, knobs and similar parts and to signal lamps and their covers but only if the lamps or covers protrude from the enclosure by more than 10 mm or if their surface area exceeds 4 cm^2 . Lamps within the appliance and their covers are only tested if they are likely to be damaged in normal use.

After the test, the appliance shall show no damage which could impair compliance with this standard; in particular, compliance with 8.1, 15.1 and 29.1 shall not be impaired. In case of doubt, SUPPLEMENTARY INSULATION or REINFORCED INSULATION is subjected to the electric strength test of 16.3.

If there is doubt as to whether a defect has occurred by the application of the preceding blows, this defect is neglected and the group of three blows is applied to the same place on a new sample which shall then withstand the test.

NOTES

1 When applying the release cone to the guard of a visibly glowing heating element, care is to be taken that the hammer head passing through the guard does not strike the heating element.

2 Damage to the finish, small dents which do not reduce CREEPAGE DISTANCES and CLEARANCE below the values specified in 29.1 and small chips which do not adversely affect protection against access to LIVE PARTS or moisture are neglected.

3 Cracks not visible to the naked eye and surface cracks in fibre-reinforced moldings and similar materials are ignored.

4 If a decorative cover is backed by an inner cover, fracture of the decorative cover is neglected if the inner cover withstands the test after removal of the decorative cover.

5 To ensure that the appliance is rigidly supported, it may be necessary to place it against a solid wall of brick, concrete or similar material, covered by a sheet of polyamide which is tightly fixed to the wall, care being taken that there is no appreciable air gap between the sheet and the wall. The sheet has a Rockwell hardness of HR 100, a thickness of at least 8 mm and a surface area such that no part of the appliance is mechanically overstressed due to insufficient supporting area.

21.1DV D2 Replace the 2nd, 3rd, 4th and 6th paragraphs of subclause 21.1 by the following and delete NOTES 1, 3, and 5.

STATIONARY APPLIANCES shall be able to withstand a minimum impact of 6.8 J (5 ft-lbs force) and counter-top appliances shall be able to withstand a minimum impact of 2 J (1,5 ft-lbs force) in accordance with the Standard for Polymeric Materials – Use in Electrical Equipment Evaluations, UL 746C. HAND-HELD APPLIANCES are subjected to the drop impact test of UL 746C.

22 Construction

22.1 If the appliance is marked with the first numeral of the IP system, the relevant requirements of IEC 60529 shall be fulfilled.

Compliance is checked by the relevant tests.

22.2 For STATIONARY APPLIANCES means shall be provided to ensure ALL-POLE DISCONNECTION from the supply. Such means shall be one of the following:

- a SUPPLY CORD fitted with a plug;
- a switch complying with 24.3;
- a statement in the instructions for installation that a disconnection incorporated in the fixed wiring is to be provided;
- an appliance coupler.

If a single-phase CLASS I APPLIANCE with heating elements, which is intended to be permanently connected to fixed wiring, incorporates single-pole switches or single-pole PROTECTIVE DEVICES intended to disconnect the heating element from the supply, these shall be connected in the phase conductor.

Compliance is checked by inspection.

22.3 Appliances with pins for insertion into socket-outlets shall not impose undue strain on these socket-outlets.

Compliance is checked by inserting the pins of the appliance, as in normal use, into a socket-outlet without earthing contact. The socket-outlet has a horizontal pivot at a distance of 8 mm behind the engagement face of the socket-outlet and in the plane of the contact tubes.

The torque which has to be applied to maintain the engagement face of the socket-outlet in the vertical plane shall not exceed 0,25 Nm.

NOTE – The torque which has to be applied to the socket-outlet without the appliance is not included in this value.

22.4 Appliances for heating liquids and appliances causing undue vibration shall not be provided with pins for insertion into socket-outlets.

Compliance is checked by inspection.

22.5 Appliances intended to be connected to the supply by means of a plug shall be constructed so that in normal use there is no risk of electric shock from charged capacitors when touching the pins of the plug.

Compliance is checked by the following test, which is made 10 times.

The appliance is supplied at RATED VOLTAGE. Any switch is then placed in the OFF POSITION and the appliance is disconnected from the supply. One second after disconnection, the voltage between the pins of the plug is measured with an instrument which does not appreciably affect the value to be measured.

The voltage shall not exceed 34 V.

NOTE – Capacitors having a rated capacitance less than or equal to 0,1 uF are not considered to entail a risk of electric shock.

22.6 Appliances shall be constructed so that their electrical insulation cannot be affected by water which could condense on cold surfaces or by liquid which could leak from containers, hoses, couplings and similar parts of the appliance. Moreover, the electrical insulation of CLASS II APPLIANCES and CLASS II CONSTRUCTIONS shall not be affected, if a hose ruptures or a seal leaks.

Compliance is checked by inspection and in case of doubt by the following test:

Drops of coloured water solution are supplied by means of a syringe to those parts inside the appliance where leakage of a liquid could occur and affect the electrical insulation. The appliance is in operation or at rest, whichever is the most unfavourable.

After this test, inspection shall show that there is no trace of liquid on windings or insulation which could result in a reduction of CREEPAGE DISTANCES below the values specified in 29.1.

22.7 Appliances containing liquid or gases in normal use or provided with steam-producing devices, shall incorporate adequate safeguards against the risk of excessive pressure.

Compliance is checked by inspection and, if necessary, by an appropriate test.

22.8 For appliances having compartments to which access can be gained without the aid of a TOOL and which are likely to be cleaned in normal use, the electrical connections shall be arranged so that they are not subject to pulling during cleaning.

Compliance is checked by inspection and by manual test.

22.9 Appliances shall be constructed so that parts such as insulation, internal wiring, windings, commutators and slip rings are not exposed to oil, grease or similar substances.

However, if the construction is such that insulation is exposed to substances such as oil or grease, the substance shall have adequate insulating properties so that compliance with the standard is not impaired.

Compliance is checked by inspection and by the tests of this standard.

22.10 Reset buttons of NON-SELF-RESETTING CONTROLS shall be located or protected so that their accidental resetting is unlikely to occur if this could result in a hazard.

Compliance is checked by inspection.

NOTE – For example, this requirement precludes reset buttons on the back of an appliance so that they can be reset by pushing the appliance against a wall.

22.11 NON-DETACHABLE PARTS which provide the necessary degree of protection against hazards to LIVE PARTS, moisture or contact with moving parts, shall be fixed in a reliable manner and shall withstand the mechanical stress occurring in normal use.

Snap-in devices used for fixing such parts shall have an obvious locked position. The fixing properties of snap-in devices used in parts which are likely to be removed during installation or servicing shall not deteriorate.

Compliance is checked by the following tests.

Parts which are likely to be removed for installation or during servicing are disassembled and assembled 10 times before the test is carried out.

NOTE – Servicing includes replacement of the SUPPLY CORD.

The appliance is at room temperature. However, in cases where compliance may be affected by temperature, the test is also carried out immediately after the appliance has been operated under the conditions specified in clause 11.

The test is applied to all parts which are likely to be detachable whether or not they are fixed by screws, rivets or similar parts.

A force is applied for 10 s in the most unfavourable direction without jerks to those areas of the cover or part which are likely to be weak. The force is as follows:

- Push force 50 N
- Pull force
 - a) If the shape of the part is such that the fingertips cannot easily slip off 50 N
 - b) If the projection of the part which is gripped is less than 10 mm in the direction of removal 30 N

The push force is applied by means of a rigid test finger similar in dimensions to the test finger shown in figure 1.

The pull force is applied by a suitable means such as a suction cup, so that the test results are not affected.

While the pull test of a) or b) is being applied, the test fingernail of figure 10 is inserted in any aperture or joint with a force of 10 N. The fingernail is then slid sideways with a force of 10 N; it is not twisted or used as a lever.

If the shape of the part is such that an axial pull is unlikely, no pull force is applied but the test fingernail of figure 10 is inserted in any aperture or joint with a force of 10 N and is then pulled for 10 s by means of the loop with a force of 30 N in the direction of removal.

If the cover or part is likely to be subjected to a twisting force, a torque as detailed below is applied at the same time as the pull or push force:

- for major dimensions up to and including 50 mm 2 Nm;
- for major dimensions over 50 mm 4 Nm.

This torque is also applied when the test finger nail is pulled by means of the loop.

If the projection of the part which is gripped is less than 10 mm, the above torque is reduced to 50% of the value.

Parts shall not become detached and they shall remain in the locked position.

22.12 Handles, knobs, grips, levers and similar parts shall be fixed in a reliable manner so that they will not work loose in normal use if loosening could result in a hazard.

If handles, knobs and similar parts are used to indicate the position of switches or similar components, it shall not be possible to fix them in a wrong position if this could result in a hazard.

Compliance is checked by inspection, by manual test and by trying to remove the handle, knob, grip or lever by applying, for 1 min, an axial force as follows:

– if the shape of these parts is such that an axial pull is unlikely to be applied in normal use, the force is 15 N;

– if the shape is such that an axial pull is likely to be applied, the force is 30 N.

NOTE – Sealing compound and similar materials, other than self-hardening resins, are not considered to be adequate to prevent loosening.

22.13 Handles shall be constructed so that, when gripped as in normal use, contact between the operator's hand and parts having a temperature rise exceeding the value specified for handles which are held for short periods only in normal use, is unlikely.

Compliance is checked by inspection and, if necessary, by determining the temperature rise.

22.14 Appliances shall have no ragged or sharp edges, other than those necessary for the function of the appliance or accessory, that could create a hazard for the user in normal use or during USER MAINTENANCE.

There shall be no exposed pointed ends of self-tapping screws or other fasteners that are liable to be touched by the user in normal use or during USER MAINTENANCE.

Compliance is checked by inspection.

22.15 Storage hooks and similar devices for flexible cords shall be smooth and well-rounded.

Compliance is checked by inspection.

22.16 Automatic cord reels shall be constructed so that they cause

- no undue abrasion or damage to the sheath of the flexible cord;*
- no breakage of conductor strands;*
- no undue wear of contacts.*

Compliance is checked by the following test, which is made without passing current through the flexible cord.

Two-thirds of the total length of the cord is unreeled. An additional length of 75 cm of the cord is then unreeled and allowed to be recoiled by the reel 6 000 times at a rate of approximately 30 times per min. or at the maximum rate permitted by the construction of the cord reel if this is less.

The cord is pulled in a direction such that the greatest abrasion occurs to the sheath, taking into account the normal position of use of the appliance. Where the cord leaves the appliance, the angle between the axis of the cord during the test and the axis of the cord when it is unreeled without substantial resistance, is to be approximately 60E.

NOTES

1 If the cord does not recoil at the angle of 60E, this angle is adjusted to the maximum that will allow recoil.

2 It may be necessary to interrupt the test to allow the cord to cool.

If the total withdrawable length of the cord is less than 225 cm, the cord is initially unreeled to such an extent that a length of 75 cm remains on the reel. This length is then tested as specified.

After this test, the cord and cord reel are inspected. In case of doubt the cord is subjected to the electric strength test of 16.3, a test voltage of 1 000 V being applied between the conductors of the cord connected together and metal foil wrapped around the cord.

22.17 Spacers intended to prevent the appliance from overheating walls shall be fixed so that it is not possible to remove them from the outside of the appliance by hand or by means of a screwdriver or a spanner.

Compliance is checked by inspection and by manual test.

22.18 Current-carrying parts and other metal parts, the corrosion of which could result in a hazard, shall be resistant to corrosion under normal conditions of use.

Compliance is checked by verifying that after the tests of clause 19, the relevant parts show no sign of corrosion.

NOTES

1 Attention is to be paid to the compatibility of the materials of terminals to the effect of heating.

2 Stainless steel and similar corrosion-resistant alloys and plated steel are considered to be satisfactory for the purpose of this requirement.

22.19 Driving belts shall not be relied upon to provide the required level of insulation.

This requirement does not apply if the appliance incorporates a belt, the design of which prevents inappropriate replacement.

Compliance is checked by inspection.

22.20 Direct contact between LIVE PARTS and thermal insulation shall be effectively prevented, unless such material is non-corrosive, non-hygroscopic and non-combustible.

Compliance is checked by inspection and, if necessary, by appropriate tests.

NOTES

1 Glass-wool is an example of thermal insulation which is satisfactory for the purpose of this requirement.

2 Non-impregnated slag-wool is an example of corrosive thermal insulation.

22.21 Wood, cotton, silk, ordinary paper and similar fibrous or hygroscopic material shall not be used as insulation, unless impregnated.

NOTE 1 – Insulating material is considered to be impregnated if the interstices between the fibres of the material are substantially filled with a suitable insulant.

NOTE 2 – Magnesium oxide and mineral ceramic fibres used for the electrical insulation of heating elements are not considered to be hygroscopic materials.

Compliance is checked by inspection.

22.22 Appliances shall not contain asbestos.

Compliance is checked by inspection.

22.23 Oils containing polychlorinated biphenyl (PCB) shall not be used in appliances.

Compliance is checked by inspection.

22.24 Bare heating elements shall be supported so that, if they rupture, the heating conductor is unlikely to come into contact with earthed metal parts or accessible metal parts.

Compliance is checked by inspection, after cutting the heating conductor in the most unfavourable place.

NOTES

1 No force is applied to the conductor after it has been cut.

2 This test is made after the tests of clause 29.

22.25 Appliances other than those of CLASS III shall be constructed so that sagging heating conductors cannot come into contact with accessible metal parts.

Compliance is checked by inspection.

NOTE – This requirement may be met by providing SUPPLEMENTARY INSULATION or a core which effectively prevents the heating conductor from sagging.

22.26 CLASS II APPLIANCES having parts of CLASS III CONSTRUCTION shall be constructed so that the insulation between parts operating at SAFETY EXTRA-LOW VOLTAGE and other LIVE PARTS complies with the requirements for DOUBLE INSULATION OR REINFORCED INSULATION.

Compliance is checked by the tests specified for DOUBLE INSULATION OR REINFORCED INSULATION.

22.27 Parts connected by PROTECTIVE IMPEDANCE shall be separated by DOUBLE INSULATION OR REINFORCED INSULATION.

Compliance is checked by the tests specified for DOUBLE INSULATION OR REINFORCED INSULATION.

22.28 For CLASS II APPLIANCES connected in normal use to the gas mains or to the water mains, metal parts conductively connected to the gas pipes or in contact with the water shall be separated from LIVE PARTS by DOUBLE INSULATION OR REINFORCED INSULATION.

Compliance is checked by inspection.

22.29 CLASS II APPLIANCES intended to be permanently connected to fixed wiring shall be constructed so that the required degree of access to LIVE PARTS is maintained after installation of the appliance.

Compliance is checked by inspection.

NOTE – The protection against access to LIVE PARTS may be affected for example, by the installation of metal conduits or cables provided with a metal sheath.

22.30 Parts of CLASS II CONSTRUCTION which serve as SUPPLEMENTARY INSULATION OR REINFORCED INSULATION and which could be omitted during reassembly after servicing, shall

– be fixed so that they cannot be removed without being seriously damaged,

or

– be constructed so that they cannot be replaced in any incorrect position and so that if they are omitted, the appliance is rendered inoperable or manifestly incomplete.

Compliance is checked by inspection and by manual test.

NOTE – Servicing includes replacement of components such as SUPPLY CORDS and switches.

22.31 CREEPAGE DISTANCES and CLEARANCES over SUPPLEMENTARY INSULATION and REINFORCED INSULATION shall not be reduced below the values specified in 29.1 as a result of wear. If any wire, screw, nut, washer, spring or similar part becomes loose or falls out of position, CREEPAGE DISTANCES and CLEARANCES over SUPPLEMENTARY INSULATION or REINFORCED INSULATION shall not be reduced to less than 50% of the value specified in 29.1.

Compliance is checked by inspection, by measurement and by manual test.

NOTE – For the purpose of this requirement:

- only the normal position of use of the appliance is taken into account;
- it is not to be expected that two independent fixings will become loose at the same time;
- parts fixed by means of screws or nuts provided with locking washers are regarded as not liable to become loose, provided these screws or nuts are not required to be removed during the replacement of the SUPPLY CORD or other servicing;
- wires connected by soldering are not considered to be adequately fixed, unless they are held in place near the terminals, independently of the solder;
- wires connected to terminals are not considered to be adequately secured, unless an additional fixing is provided near to the terminal, so that in the case of stranded conductors, this fixing clamps both the insulation and the conductor;
- short rigid wires are not regarded as liable to come away from a terminal if they remain in position when the terminal screw is loosened.

22.32 SUPPLEMENTARY INSULATION and REINFORCED INSULATION shall be designed or protected so that the deposition of dirt or the dust resulting from wear of parts within the appliance, does not reduce CREEPAGE DISTANCES or CLEARANCES below the values specified in 29.1.

Ceramic material which is not tightly sintered, similar materials or beads alone shall not be used as SUPPLEMENTARY INSULATION or REINFORCED INSULATION.

Parts of natural or synthetic rubber used as SUPPLEMENTARY INSULATION shall be resistant to ageing or be arranged and dimensioned so that CREEPAGE DISTANCES are not reduced below the values specified in 29.1 even if cracks occur.

NOTE 1 – Insulating material in which heating conductors are embedded is considered to be BASIC INSULATION and not REINFORCED INSULATION.

Compliance is checked by inspection, by measurement and, for rubber, by the following test.

Parts of rubber are aged in an atmosphere of oxygen under pressure. The samples are suspended freely in an oxygen bomb, the effective capacity of the bomb being at least ten times the volume of the samples. The bomb is filled with commercial oxygen not less than 97% pure, to a pressure of 2,1 MPa ± 0,07 MPa.

The samples are kept in the bomb at a temperature of 70EC ±1EC for 96 h. Immediately afterwards they are removed from the bomb and left at room temperature, avoiding direct sunlight, for at least 16 h.

After the test, the samples are examined and shall show no crack visible to the naked eye.

NOTES

2 In case of doubt with regard to materials other than rubber, other tests may be made.

3 The use of the oxygen bomb presents some danger unless handled with care. Precautions should be taken to avoid the risk of explosion due to sudden oxidation.

4 – In case of doubt, the following test is carried out to determine if ceramic material is tightly sintered. The ceramic material is broken into pieces which are immersed in a solution containing 1 g of fuchsine in each 100 g of methylated spirit. The solution is maintained at a pressure not less than 15 MPa for a period so that the product of the test duration in hours and the test pressure in MPa is not less than 180.

The pieces are removed from the solution, rinsed, dried and broken into smaller pieces.

The freshly broken surfaces are examined and are not to show any trace of dye.

22.33 Conductive liquids which are or may become accessible in normal use shall not be in direct contact with LIVE PARTS. Electrodes shall not be used for heating liquids.

For CLASS II CONSTRUCTION, conductive liquids which are or may become accessible in normal use shall not be in direct contact with BASIC INSULATION OR REINFORCED INSULATION.

For CLASS II CONSTRUCTION, conductive liquids which are in contact with LIVE PARTS, shall not be in direct contact with REINFORCED INSULATION.

NOTE 1 – Liquids which are not in contact with unearthed ACCESSIBLE METAL PARTS are considered to be accessible.

NOTE 2 – An air layer is not considered to be sufficient as one of the layers of DOUBLE INSULATION if it is likely to be bridged by leaking liquid.

Compliance is checked by inspection.

22.34 Shafts of operating knobs, handles, levers and similar parts shall not be live unless the shaft is not accessible when the part is removed.

Compliance is checked by inspection and by applying the test finger as specified in 8.1 after removal of the part even with the aid of a TOOL.

22.35 For constructions other than those of CLASS III, handles, levers and knobs which are held or actuated in normal use shall not become live in the event of an insulation fault. If these handles, levers or knobs are of metal and if their shafts or fixings are likely to become live in the event of an insulation fault, they shall either be adequately covered by insulating material or their ACCESSIBLE PARTS shall be separated from their shafts or fixings by SUPPLEMENTARY INSULATION.

NOTE – The insulation material is considered to be adequate if it complies with the test of 16.3, table 5, item 4.

For STATIONARY APPLIANCES this requirement does not apply to handles, levers and knobs, other than those of electrical components, provided they are either reliably connected to an earthing terminal or earthing contact or separated from LIVE PARTS by earthed metal.

Compliance is checked by inspection and if necessary by the relevant tests.

22.36 For appliances other than those of CLASS III, handles which are continuously held in the hand in normal use shall be constructed so that when gripped as in normal use, the operator's hand is not likely to touch metal parts unless they are separated from LIVE PARTS by DOUBLE INSULATION OR REINFORCED INSULATION.

Compliance is checked by inspection.

22.37 For CLASS II APPLIANCES, capacitors shall not be connected to accessible metal parts and their casings, if of metal, shall be separated from accessible metal parts by SUPPLEMENTARY INSULATION.

This requirement does not apply to capacitors complying with the requirements for PROTECTIVE IMPEDANCE specified in 22.42.

Compliance is checked by inspection and by the relevant tests.

22.38 Capacitors shall not be connected between the contacts of a THERMAL CUT-OUT.

Compliance is checked by inspection.

22.39 Lampholders shall be used only for the connection of lamps.

Compliance is checked by inspection.

22.40 MOTOR-OPERATED APPLIANCES and COMBINED APPLIANCES, which are intended to be moved while in operation, or which have accessible moving parts, shall be fitted with a switch to control the motor. The actuating member of this switch shall be easily visible and accessible.

22.41 Mercury switches shall be mounted so that the mercury capsule cannot fall out of position or be damaged by the clamping means and they shall be arranged so that, should the capsule break, liquid or vaporous mercury cannot be released so as to contaminate the surroundings.

Compliance is checked by inspection.

22.42 PROTECTIVE IMPEDANCE shall consist of at least two separate components whose impedance is unlikely to change significantly during the lifetime of the appliance. If any one of the components is short-circuited or open-circuited the values specified in 8.1.4 shall not be exceeded.

Compliance is checked by inspection and by measurement.

NOTE 1 – Resistors complying with test a) of subclause 14.1 of IEC 60065 and capacitors complying with IEC 60384-14 are considered to be components having a sufficiently stable impedance.

NOTE 2 – Class X capacitors specified in IEC 60384-14 are not considered to be suitable components for use as PROTECTIVE IMPEDANCE

22.43 Appliances which can be adjusted for different voltages shall be constructed so that accidental changing of the setting is unlikely to occur.

Compliance is checked by manual test.

22.44 Appliances shall not have an enclosure which is shaped and decorated so that the appliance is likely to be treated as a toy by children.

Compliance is checked by inspection.

NOTE – Examples are enclosures representing animals or persons or resembling scale models.

23 Internal wiring

23.1 Wireways shall be smooth and free from sharp edges.

Wires shall be protected so that they do not come into contact with burrs, cooling fins or similar edges which may cause damage to their insulation.

Holes in metal through which insulated wires pass shall have smooth well-rounded surfaces or be provided with bushings.

Wiring shall be effectively prevented from coming into contact with moving parts.

Compliance is checked by inspection.

23.2 Beads and similar ceramic insulators on live wires shall be fixed or supported so that they cannot change their position; they shall not rest on sharp edges or sharp corners. If beads are inside flexible metal conduits, they shall be contained within an insulating sleeve, unless the conduit cannot move in normal use.

Compliance is checked by inspection and by manual test.

23.3 Different parts of an appliance which can move in normal use or during USER MAINTENANCE relative to each other, shall not cause undue stress to electrical connections and internal wiring, including those providing earthing continuity. Flexible metallic tubes shall not cause damage to the insulation of the conductors contained within them. Open-coil springs shall not be used to protect conductors. If a coiled spring, the turns of which touch one another, is used for this purpose, an adequate insulating lining shall be provided in addition to the insulation of the conductors.

Compliance is checked by inspection and by the following test.

If flexing occurs in normal use, the appliance is placed in the normal position of use and is supplied at RATED VOLTAGE under NORMAL OPERATION.

The movable part is moved backwards and forwards, so that the conductor is flexed through the largest angle permitted by the construction. The number of flexings for conductors flexed in normal use is 10 000 and the rate of flexing 30 per min; for conductors flexed during USER MAINTENANCE the number is 100 with the same rate of flexing.

The appliance shall not be damaged to the extent that compliance with this standard is impaired and it shall be fit for further use. In particular, the wiring and its connections shall withstand the electric strength test of 16.3, the test voltage being however reduced to 1 000 V and applied between LIVE PARTS and other metal parts only.

NOTES

1 A flexing is one movement, either backwards or forwards.

2 The sheath of a flexible cord complying with IEC 60227 or IEC 60245 is regarded as an adequate insulating lining.

23.4 Bare internal wiring shall be rigid and fixed so that, in normal use, CREEPAGE DISTANCES and CLEARANCES cannot be reduced below the values specified in 29.1.

Compliance is checked during the test of 29.1.

23.5 The insulation of internal wiring shall withstand the electrical stress likely to occur in normal use.

Compliance is checked as follows:

The basic insulation shall be electrically equivalent to the basic insulation of cords complying with IEC 60227 or IEC 60245 or comply with the following electric strength test:

A voltage of 2 000 V is applied for 15 min between the conductor and metal foil wrapped around the insulation. There shall be no breakdown.

NOTES

1 If the insulation of the conductor does not fulfill one of these conditions, the conductor is considered to be bare.

2 The test is only applied to wiring subjected to the supply mains voltage.

3 For CLASS II CONSTRUCTION, the requirements for SUPPLEMENTARY INSULATION and REINFORCED INSULATION apply, except that the sheath of a cord complying with IEC 60227 or IEC 60245 may provide SUPPLEMENTARY INSULATION.

23.5DV D1 Replace the two paragraphs of the compliance statement and the NOTES 1 – 3 of 23.5 by the following:

Internal wiring shall be suitable for intended application, temperature, electrical stress, and other conditions of intended usage. See annex DVC.

23.6 When sleeving is used as SUPPLEMENTARY INSULATION on internal wiring it shall be retained in position by positive means.

Compliance is checked by inspection and by manual test.

NOTE – A sleeve is considered to be fixed by positive means if it can only be removed by breaking or cutting or if it is clamped at both ends.

23.7 Conductors identified by the colour combination green/yellow shall only be used for earthing conductors.

Compliance is checked by inspection.

23.8 Aluminum wires shall not be used for internal wiring.

Compliance is checked by inspection.

NOTE – Windings are not considered as internal wiring.

23.9 Stranded conductors shall not be consolidated by lead-tin soldering where they are subjected to contact pressure, unless the clamping means is constructed so that there is no risk of bad contact due to cold flow of the solder.

Compliance is checked by inspection.

NOTES

1 The requirements may be met by using spring terminals. Securing the clamping screws alone is not considered adequate.

2 Soldering of the tip of a stranded conductor is allowed.

24 Components

24DV DC Add the following to clause 24:

In this standard all IEC component standard requirements are replaced by the relevant requirements of UL component standards, examples of which are given in annex DVC.

24.1 Components shall comply with the safety requirements specified in the relevant IEC standards as far as they reasonably apply.

Compliance is checked by inspection and by the tests of 24.1.1 to 24.1.5.

NOTES 1 – Compliance with the IEC standard for the relevant component does not necessarily ensure compliance with the requirements of this standard.

NOTE 2 – Unless otherwise specified, the requirements of clause 29 apply between LIVE PARTS of components and ACCESSIBLE PARTS of the appliance.

24.1DV DC *Replace the compliance paragraph of 24.1 with the following:*

In this standard, for components, compliance is checked by the evaluation of the construction and the test requirements of applicable standards, examples of which are given in annex DVC.

24.1.1 *Capacitors likely to be permanently subjected to the supply mains voltage and used for radio interference suppression or for voltage dividing shall comply with annex Q.*

NOTE – Examples of capacitors likely to be permanently subjected to the supply mains voltage are capacitors incorporated in appliances

– for which 30.2.3 is applicable;

– for which 30.2.2 is applicable, unless the capacitor is disconnected from the supply by the on-off switch. This switch has to be double-pole if the capacitor is connected to earth.

Small lampholders similar to E10 lampholders shall comply with the requirements for E10 lampholders; they need not accept a lamp with E10 cap complying with the current edition of Standard Sheet 7004-22 of IEC 60061-1.

SAFETY ISOLATING TRANSFORMERS which have not been separately tested and found to comply with IEC 61558-2-6 shall comply with annex R.

Appliance couplers for IPX0 appliances shall comply with IEC 60320. Other appliance couplers shall comply with IEC 60309.

Automatic controls shall comply with IEC 60730 unless they are tested with the appliance.

Switches shall comply with IEC 61058-1 unless they are tested with the appliance.

24.1.2 *Automatic controls which have not been separately tested and found to comply with IEC 60730 shall be tested according to this standard and according to subclauses 11.3.5 to 11.3.8 and clause 17 of IEC 60730 as type 1 controls.*

The tests according to IEC 60730 are carried out under the conditions occurring in the appliance.

For the tests of clause 17 of IEC 60730 the number of cycles of operation are

| | |
|---------------------------------------|--------|
| – THERMOSTATS | 10 000 |
| – TEMPERATURE LIMITERS | 1 000 |
| – SELF-RESETTING THERMAL CUT-OUTS | 300 |
| – NON-SELF-RESETTING THERMAL CUT-OUTS | 30 |

| | |
|---------------------|--------|
| – TIMERS | 3 000 |
| – ENERGY REGULATORS | 10 000 |

NOTES

1 The tests of clauses 12, 13 and 14 are not carried out before making the test of clause 17 of IEC 60730.

2 The tests of clause 17 of IEC 60730 are not carried out on automatic controls which operate during clause 11, if the appliance meets the requirements of this standard when they are short-circuited.

3 Automatic controls may be tested separately from the appliance.

24.1.3 *Switches which have not been separately tested and found to comply with IEC 61058-1 under conditions covering those occurring in the appliance, shall comply with annex S.*

The test of subclause 17.2.7 of IEC 61058-1 is carried out for 10 000 cycles of operation.

Switches intended for operation under no load and which can be operated only with the aid of a TOOL are not subjected to the tests of clause 17 of IEC 61058-1. This applies also for such switches operated by hand which are interlocked so that they cannot be operated under load but switches without this interlock are subjected to the test of subclause 17.2.7 of IEC 61058-1 for 100 cycles of operation.

NOTE – The test of subclause 17.2.7 of IEC 61058-1 is only carried out on switches required by this standard.

24.1.4 *If components are marked with their operating characteristics, the conditions under which they are used in the appliance shall be in accordance with these markings, unless otherwise specified.*

NOTE – For automatic controls, the term "marking" includes documentation and declaration as specified in clause 7 of IEC 60730.

The testing of components which have to comply with other standards is, in general, carried out separately, according to the relevant standard.

If the component is used within the limits of its marking, it is tested in accordance with the conditions occurring in the appliance, the number of samples being that required by the relevant standard.

When no IEC standard exists for the relevant component, when the component is not marked or is not used in accordance with its marking, it is tested under the conditions occurring in the appliance. The number of samples is, in general, that required by a similar specification.

Components not mentioned in table 3 are tested as a part of the appliance, their T-marking, if any, being taken into account.

24.1.5 *For capacitors connected in series with a motor winding, it is verified that, when the appliance is supplied at 1,1 times RATED VOLTAGE and under minimum load, the voltage across the capacitor does not exceed 1,1 times its RATED VOLTAGE.*

Capacitors in appliances for which 30.2.3 is applicable and which are permanently connected in series with a motor winding shall be of class P1 or P2 of IEC 60252.

NOTE – Capacitors in auxiliary windings of motors are to be marked with their RATED VOLTAGE and their rated capacitance.

24.2 Appliances shall not be fitted with

- switches or automatic controls in flexible cords;
- devices which cause the PROTECTIVE DEVICE in the fixed wiring to operate in the event of a fault in the appliance;
- THERMAL CUT-OUTS which can be reset by a soldering operation.

NOTE – The use of solder having a melting point at least 230EC is allowed.

Compliance is checked by inspection.

24.3 Switches intended to ensure ALL-POLE DISCONNECTION of STATIONARY APPLIANCES, as required in 22.2, shall be directly connected to the supply terminals and shall have a contact separation of at least 3 mm in each pole.

Compliance is checked by inspection and by measurement.

24.4 Plugs and socket-outlets used as terminal devices for heating elements and plugs and socket-outlets for EXTRA-LOW VOLTAGE circuits, shall not be interchangeable with plugs and socket-outlets listed in IEC 60083 or IEC 60906-1 or with connectors and appliance inlets complying with the standard sheets of IEC 60320.

Compliance is checked by inspection.

24.5 Plugs and socket-outlets and other connecting devices of INTERCONNECTION CORDS shall not be interchangeable with plugs and socket-outlets listed in IEC 60083 or IEC 60083 or with connectors and appliance inlets complying with the standard sheets of IEC 60320, if direct supply to these parts from the supply mains could give rise to a hazard.

Compliance is checked by inspection and by manual test.

24.6 Motors connected to the supply mains and having BASIC INSULATION which is inadequate for the RATED VOLTAGE of the appliance, shall comply with the requirements of annex F.

Compliance is checked by the tests of annex F.

25 Supply connection and external flexible cords

25.1 Appliances, other than those intended to be permanently connected to fixed wiring, shall be provided with one of the following means for connection to the supply:

- SUPPLY CORD fitted with a plug;
- an appliance inlet having at least the same degree of protection against moisture as required for the appliance;
- pins for insertion into socket-outlets.

Compliance is checked by inspection.

25.2 Appliances other than STATIONARY APPLIANCES for multiple supply shall not be provided with more than one means of connection to the supply. STATIONARY APPLIANCES for multiple supply may be provided with more than one means of connection provided the relevant circuits are adequately insulated from each other.

Compliance is checked by inspection and by the following test.

A voltage of 1 250 V of substantially sinusoidal waveform and having a frequency of 50 Hz or 60 Hz is applied for 1 min between each means of connection to the supply, any switches being in the most unfavourable position.

During this test, no breakdown shall occur.

NOTES

1 A multiple supply is, for example, required for day and night supply at different tariffs.

2 This test may be combined with that of 16.3.

25.3 Appliances intended to be permanently connected to fixed wiring shall allow the connection of the supply wires after the appliance has been fixed to its support and shall be provided with one of the following means for connection to the supply:

– a set of terminals allowing the connection of cables of fixed wiring having the nominal cross-sectional areas specified in 26.2;

– a set of terminals allowing the connection of a flexible cord;

NOTE 1 – In this case it is allowed to connect the SUPPLY CORD before the appliance is fixed to its support. The appliance may be provided with a flexible cord.

– a set of SUPPLY LEADS accommodated in a suitable compartment;

– a set of terminals and cable entries, conduit entries, knock-outs or glands, which allow the connection of the appropriate types of cable or conduit.

NOTE 2 – If a FIXED APPLIANCE is constructed so that parts can be removed to facilitate easy installation, the requirement is considered to be met if it is possible to connect the supply wires without difficulty after a part of the appliance has been fixed to its support. In this case removable parts are to be constructed to be easily reassembled to the part which has been fixed in position, without risk of incorrect assembly or damage to the wiring and without exposing the wiring to stress which may cause damage to the terminals or to the insulation of the wires.

Compliance is checked by inspection and if necessary by making the appropriate connections.

25.4 For appliances having a RATED CURRENT not exceeding 16A, cable and conduit entries shall be suitable for cables or conduits having a maximum overall diameter shown in table 8.

Conduit entries, cable entries and knock-outs shall be constructed or located so that the introduction of the conduit or cable does not affect the protection against access to LIVE PARTS or reduce CREEPAGE DISTANCES and CLEARANCES below the value specified in 29.1.

Compliance is checked by inspection and by measurement.

Table 8 – Diameter of cables and conduits

| Number of conductors including earthing conductors | Maximum overall diameter mm | |
|--|-----------------------------|-----------------------|
| | Cable | Conduit ¹⁾ |
| 2 | 13,0 | 16,0 (23,0) |
| 3 | 14,0 | 16,0 (23,0) |
| 4 | 14,5 | 20,0 (23,0) |
| 5 | 15,5 | 20,0 (29,0) |

1) The diameters in parentheses are for use in U.S.A. and Canada.

25.5 SUPPLY CORDS shall be assembled to the appliance by one of the following methods:

- TYPE X ATTACHMENT;
- TYPE Y ATTACHMENT;
- TYPE Z ATTACHMENT, if allowed in part 2.

TYPE X ATTACHMENT other than those with a specially prepared cord, shall not be used for flat twin tinsel cords.

Compliance is checked by inspection.

25.6 Plugs shall not be fitted with more than one flexible cord.

Compliance is checked by inspection.

25.7 SUPPLY CORDS shall not be lighter than

- braided cord (code designation 245 IEC 60051);
- ordinary tough rubber sheathed cord (code designation 245 IEC 60053);
- flat twin tinsel cord (code designation 227 IEC 60041);
- light polyvinyl chloride sheathed cord (code designation 227 IEC 60052), for appliances having a mass not exceeding 3 kg;
- ordinary polyvinyl chloride sheathed cord (code designation 227 IEC 60053), for appliances having a mass exceeding 3 kg.

NOTES

1 Braided cords and flat twin tinsel cords may only be used if allowed in part 2.

2 A lower number in the code designation of the cord in IEC 60227 or IEC 60245 indicates a lighter type.

Polyvinyl chloride sheathed cords shall not be used for appliances where the temperature rise of external metal parts exceeds 75 K during the test of clause 11. However they may be used if

- the appliance is constructed so that the SUPPLY CORD is not likely to touch such metal parts in normal use;
- the SUPPLY CORD is appropriate for higher temperatures. In this case, TYPE Y ATTACHMENT or TYPE Z ATTACHMENT shall be used.

Compliance is checked by inspection and by measurement.

25.7DV DC Replace subclause 25.7 with the following:

The type, minimum length, and other requirements for the power SUPPLY CORD are covered in the part 2 standards.

25.8 Conductors of SUPPLY CORDS shall have a nominal cross-sectional area not less than that shown in table 9.

Compliance is checked by measurement.

25.8DV DR Replace subclause 25.8 with the following:

Ampacities and the cross section sizes of conductors of SUPPLY CORDS shall be in accordance with the National Electrical Code ANSI/NFPA 70.

Table 9 – Minimum cross-sectional area of conductors

| RATED CURRENT of appliance A | | | | | Nominal cross-sectional area mm ² |
|------------------------------|-----|-----|---|-----|--|
| | | | # | 0,2 | tinsel cord ¹⁾ |
| > | 0,2 | and | # | 3 | 0,5 ¹⁾ |
| > | 3 | and | # | 6 | 0,75 |
| > | 6 | and | # | 10 | 1 |
| > | 10 | and | # | 16 | 1,5 |
| > | 16 | and | # | 25 | 2,5 |
| > | 25 | and | # | 32 | 4 |
| > | 32 | and | # | 40 | 6 |
| > | 40 | and | # | 63 | 10 |

1) These cords may only be used if their length does not exceed 2 m between the point where the cord or cord guard enters the appliance and the entry to the plug.

25.9 SUPPLY CORDS shall not be in contact with sharp points or edges of the appliance.

Compliance is checked by inspection.

25.10 The SUPPLY CORD of CLASS I APPLIANCES shall have a green-yellow core which is connected to the earthing terminal of the appliance and to the earthing contact of the plug.

Compliance is checked by inspection.

25.11 Conductors of SUPPLY CORDS shall not be consolidated by lead-tin soldering where they are subject to contact pressure, unless the clamping means is constructed so that there is no risk of a bad contact due to cold flow of the solder.

Compliance is checked by inspection.

NOTES

1 The requirement may be met by using spring terminals. Securing the clamping screws alone is not considered adequate.

2 Soldering of the tip of a stranded conductor is allowed.

25.12 The insulation of the SUPPLY CORD shall not be damaged when moulding the cord to part of the enclosure.

Compliance is checked by inspection.

25.13 Inlet openings shall be provided with a bushing or shall be constructed so that the sheath of the SUPPLY CORD can be introduced without risk of damage.

Compliance is checked by inspection and by manual test.

25.13.1 Inlet bushings shall

- be shaped to prevent damage to the SUPPLY CORD;
- not be DETACHABLE PARTS.

Compliance is checked by inspection and by manual test.

25.13.2 At inlet openings, the insulation between the conductor of a SUPPLY CORD and the enclosure of the appliance shall consist of the insulation of the conductor and in addition

- for CLASS 0 APPLIANCES, at least one separate insulation;
- for other appliances, at least two separate insulations.

Only one separate insulation is required if the enclosure at the inlet opening is of insulating material.

A separate insulation shall consist of

- the sheath of a SUPPLY CORD at least equivalent to that of a cord complying with IEC 60227 or IEC 60245;
- a lining or bushing of insulating material complying with the requirements of 29.2 for SUPPLEMENTARY INSULATION.

Compliance is checked by inspection.

25.14 Appliances provided with a SUPPLY CORD which are moved while in operation, shall be constructed so that the cord is adequately protected against excessive flexing where it enters the appliance.

NOTE 1 – This does not apply to appliances with automatic cord reels which are tested by 22.16 instead.

Compliance is checked by the following test which is made on an apparatus having an oscillating member as shown in figure 11.

The part of appliance comprising the cord entry, the cord guard, if any, and the SUPPLY CORD, is fixed to the oscillating member so that, when the latter is at the middle of its travel, the axis of the cord where it enters the cord guard or inlet is vertical and passes through the axis of oscillation. The major axis of the section of flat cords shall be parallel to the axis of oscillation.

The cord is loaded so that the force applied is

- 10 N for cords having a nominal cross-sectional area exceeding $0,75 \text{ mm}^2$;*
- 5 N for other cords.*

The distance A, as shown in the figure 11, between the axis of oscillation and the point where the cord or cord guard enters the appliance, is adjusted so that when the oscillating member moves over its full range, the cord and load make the minimum lateral movement.

The oscillating member is moved through an angle of 90E (45E on either side of the vertical), the number of flexings for TYPE Z ATTACHMENT being 20 000 and for other attachments 10 000. The rate of flexing is 60 per min.

NOTE 2 – A flexing is one movement of 90E.

The cord and its associated parts are turned through an angle of 90E after half the number of flexings, unless a flat cord is fitted.

During the test, the conductors are loaded with the RATED CURRENT of the appliance at RATED VOLTAGE.

NOTE 3 – Current is not passed through the earthing conductor.

The test shall not result in

- short circuit between the conductors;*
- breakage of more than 10% of the strands of any conductor;*
- separation of the conductor from its terminal;*
- loosening of any cord guard;*
- damage to the cord or cord guard which could impair compliance with this standard;*
- broken strands piercing the insulation and becoming accessible.*

NOTES

4 Conductors include earthing conductors.

5 A short circuit between conductors of the cord is considered to occur if the current exceeds a value equal to twice the RATED CURRENT of the appliance.

25.15 Appliances provided with a SUPPLY CORD shall have cord anchorages such that the conductors are relieved from strain, including twisting, where they are connected within the appliance and that the insulation of the conductors is protected from abrasion. This requirement also applies to appliances intended to be permanently connected to the fixed wiring by a flexible cord.

It shall not be possible to push the cord into the appliance to such an extent that the cord or internal parts of the appliance could be damaged.

Compliance is checked by inspection, by manual test and by the following test.

A mark is made on the cord while it is subjected to the pull force shown in table 10, at a distance of approximately 2 cm from the cord anchorage or other suitable point.

The cord is then pulled 25 times with the force specified. The pulls are applied in the most unfavourable direction without jerks, each time for 1 s.

The cord, other than that of an automatic cord reel, is then immediately subjected to a torque which is applied as close as possible to the appliance. The torque as specified in table 10 is applied for 1 min.

During the tests the cord shall not be damaged.

After the tests the cord shall not be longitudinally displaced by more than 2 mm and the conductors shall not have moved over a distance of more than 1 mm in the terminals. There shall be no appreciable strain at the connection and CREEPAGE DISTANCES and CLEARANCES shall not be reduced below the values specified in 29.1.

NOTE – The displacement of the mark on the cord in relation to the cord anchorage or other point is measured while the cord is subjected to the pull.

Table 10 – Pull force and torque

| Mass of appliance kg | Pull force N | Torque Nm |
|----------------------|--------------|-----------|
| # 1 | 30 | 0,1 |
| > 1 and # 4 | 60 | 0,25 |
| > 4 | 100 | 0,35 |

25.16 Cord anchorages for TYPE X ATTACHMENTS shall be constructed and located so that

- replacement of the cord is easily possible;
- it is clear how the relief from strain and the prevention of twisting are obtained;
- they are suitable for the different types of cord which may be connected, unless the cord is specially prepared;
- the cord cannot touch the clamping screws of the cord anchorage if these screws are accessible, unless they are separated from accessible metal parts by SUPPLEMENTARY INSULATION;
- the cord is not clamped by a metal screw which bears directly on the cord;
- at least one part of the cord anchorage is securely fixed to the appliance unless it is part of a specially prepared cord;
- screws which have to be operated when replacing the cord do not fix any other component. However this does not apply if
 - the screws are omitted or components are incorrectly positioned and the appliance becomes inoperative or is obviously incomplete;
 - the parts intended to be fastened by them cannot be removed without the aid of a TOOL during the replacement of the cord.
- if labyrinths can be bypassed the test of 25.15 is nevertheless withstood;
- for CLASS 0, CLASS 0I AND CLASS I APPLIANCES, they are of insulating material or are provided with an insulating lining, unless a failure of the insulation of the cord does not make accessible metal parts live;
- for CLASS II APPLIANCES, they are of insulating material or if of metal, they are insulated from accessible metal parts by SUPPLEMENTARY INSULATION.

NOTES

1 If the cord anchorage for TYPE X ATTACHMENT comprises one or more clamping members to which pressure is applied by means of nuts engaging with studs which are securely attached to the appliance, the cord anchorage is considered to have one part securely fixed to the appliance, even if the clamping member can be removed from the studs.

2 If the pressure on the clamping members is applied by means of one or more screws engaging with separate nuts or with a thread in a part which is integral with the appliance, the cord anchorage is not considered to have one part securely fixed to the appliance. This does not apply if one of the clamping members is fixed to the appliance or the surface of the appliance is of insulating material and shaped so that it is obvious that this surface is one of the clamping members.

3 Examples of acceptable and unacceptable constructions of cord anchorages are shown in figure 13.

Compliance is checked by inspection and by the test of 25.15 under the following conditions.

The tests are made with the lightest permissible type of cord of the smallest cross-sectional area specified in table 11 and then with the next heavier type cord having the largest cross-sectional area specified. However, if the appliance is fitted with a specially prepared cord, the test is carried out with this cord.

The conductors are placed in the terminals and any terminal screws tightened just sufficiently to prevent the conductors from easily changing their position. The clamping screws of the cord anchorage are tightened with two-thirds of the torque specified in 28.1.

Screws of insulating material bearing directly on the cord are fastened with two-thirds of the torque specified in column 1 of table 12, the length of the slot in the screw head being taken as the nominal diameter of the screw.

25.17 For TYPE Y ATTACHMENT and TYPE Z ATTACHMENT, cord anchorages shall be adequate.

Compliance is checked by the test of 25.15.

NOTE – The test is carried out on the cord supplied with the appliance.

25.18 Cord anchorages shall be arranged so that they are only accessible with the aid of a TOOL or be constructed so that the cord can only be fitted with the aid of a TOOL.

Compliance is checked by inspection.

25.19 For TYPE X ATTACHMENT, glands shall not be used as cord anchorages in PORTABLE APPLIANCES. Tying the cord into a knot or tying the cord with string is not allowed.

Compliance is checked by inspection.

25.20 The insulated conductors of the SUPPLY CORD for TYPE Y ATTACHMENT and TYPE Z ATTACHMENT shall be additionally insulated from accessible metal parts by BASIC INSULATION for CLASS 0, CLASS 0I AND CLASS I APPLIANCES, and by SUPPLEMENTARY INSULATION for CLASS II APPLIANCES. This insulation may be provided by the sheath of the SUPPLY CORD or by other means.

Compliance is checked by inspection and by the relevant tests.

25.21 The space for connection of the supply cables for fixed wiring or for the connection of the SUPPLY CORD provided for TYPE X ATTACHMENT shall be constructed

- to permit checking that the supply conductors are correctly positioned and connected before fitting any cover;
- so that any covers can be fitted without risk of damage to the conductors or their insulation;
- for PORTABLE APPLIANCES, so that the uninsulated end of a conductor, should it become free from the terminal, cannot come into contact with accessible metal parts, unless the end of the cord is such that the conductors are unlikely to slip free.

Compliance is checked by inspection and by an installation test with cables or flexible cords of the largest cross-sectional area specified in table 11.

PORTABLE APPLIANCES are subjected to the following additional test.

For pillar terminals where the SUPPLY CORD is not clamped at a distance of 30 mm or less from the terminal and for other terminals with screw clamping, the clamping screws or nuts are loosened in turn. A force of 2 N is then applied to the conductor in any direction at a position adjacent to the terminal. The uninsulated end of the conductor shall not come into contact with accessible metal parts.

NOTES

- 1 This test is not carried out on appliances with pillar terminals where the SUPPLY CORD is clamped at a distance of 30 mm or less from the terminal.**
- 2 The SUPPLY CORD may be clamped by a cord anchorage.**

25.22 Appliance inlets shall

- be located or enclosed so that LIVE PARTS are not accessible during insertion or removal of the connector;
- be located so that the connector can be inserted without difficulty;
- be located so that, after insertion of the connector, the appliance is not supported by the connector when it is placed in any position of normal use on a flat surface;
- not be an appliance inlet for cold conditions if the temperature rise of external metal parts of the appliance exceeds 75 K during the test of clause 11, unless the appliance is such that the SUPPLY CORD is not likely to touch such metal parts in normal use.

Compliance is checked by inspection.

NOTE – Appliances provided with appliance inlets complying with IEC 60320, are considered to comply with the first requirement.

25.23 INTERCONNECTION CORDS shall comply with the requirements for the SUPPLY CORD, except that

- the cross-sectional area of the conductors of the INTERCONNECTION CORD is determined on the basis of the maximum current carried by the conductor during the test of clause 11 and not by the RATED CURRENT of the appliance;
- the thickness of the insulation of the conductor may be reduced if the voltage of the conductor is less than the RATED VOLTAGE.

Compliance is checked by inspection, by measurement and if necessary by tests, such as the electric strength test of 16.3.

25.24 Detachable INTERCONNECTION CORDS shall not be provided with a means for connection such that accessible metal parts are live when the connection is disconnected due to the disengagement of one of the connecting means.

Compliance is checked by inspection and if necessary by means of the test finger of figure 1.

25.25 INTERCONNECTION CORDS shall not be detachable without the aid of a TOOL if compliance with this standard is impaired when they are disconnected.

Compliance is checked by inspection and if necessary by appropriate tests.

26 Terminals for external conductors

26.1.1 Appliances with TYPE X ATTACHMENT and appliances for connection to fixed wiring shall be provided with terminals in which connection is made by means of screws, nuts or equally effective devices. This requirement does not apply to appliances provided with SUPPLY LEADS or provided with a TYPE X ATTACHMENT having a specially prepared cord.

Screws and nuts shall not serve to fix any other component, except that they may also clamp internal conductors if these are arranged so that they are unlikely to be displaced when fitting the supply conductors.

Compliance is checked by inspection.

NOTES

1 Safety requirements for screw type and screwless type clamping units for electrical copper conductors are under consideration. Screwless type clamping units according to subclause 2.10 of IEC 60999 provided with an actuating element are regarded as equally effective devices.

2 Requirements for screwless terminals are given in IEC 60998-2-2.

26.1.2 For appliances with TYPE X ATTACHMENT, soldered connections may be used for the connection of external conductors, provided that the conductor is positioned or fixed so that reliance is not placed upon the soldering alone to maintain the conductor in position. However soldering alone may be used if barriers are provided so that CREEPAGE DISTANCES and CLEARANCES between LIVE PARTS and other metal parts cannot be reduced to less than 50% of the values specified in 29.1 if the conductor becomes free at the soldered joint.

For appliances with TYPE Y ATTACHMENT or TYPE Z ATTACHMENT, soldered, welded, crimped and similar connection may be used for the connection of external conductors. For CLASS II APPLIANCES, the conductor shall be positioned or fixed so that reliance is not placed upon the soldering, crimping or welding alone to maintain the conductor in position. However solder, welding or crimping alone may be used if barriers are provided so that CREEPAGE DISTANCES and CLEARANCES between LIVE PARTS and other metal parts cannot be reduced to less than 50% of the values specified in 29.1 if the conductor becomes free at the soldered or welded joint or slips out of the crimped connection.

Compliance is checked by inspection and by measurement.

NOTES

- 1 It is not to be expected that two independent fixings will become loose at the same time.
- 2 Conductors connected by soldering alone are not considered to be adequately fixed, unless they are held in place near the terminal. However, "hooking in" before soldering is considered to be a suitable means for maintaining the conductors in position, other than those of a tinsel cord, provided the hole through which the conductor is passed is not unduly large.
- 3 Conductors connected to terminals by other means are not considered to be adequately fixed, unless an additional fixing is provided near to the terminal. This additional fixing is to clamp both the insulation and the conductor of flexible cords.
- 4 The terminals of a component such as a switch may be used as terminals for external conductors if they comply with the requirements of this clause.

26.2 Terminals for TYPE X ATTACHMENT and for connection to fixed wiring shall allow the connection of conductors having nominal cross-sectional areas as shown in table 11. However if a specially prepared cord is used, the terminals need only be suitable for the connection of that cord.

Compliance is checked by inspection, by measurement and by fitting cable or cords of the smallest and largest cross-sectional areas specified.

26.2DV D1 Modification

Replace the wording "shown in table 11" in the first paragraph by "in accordance with the NEC" and delete table 11.

Table 11 – Nominal cross-sectional area of conductors

| RATED CURRENT of appliance A | Nominal cross-sectional area mm ² | | | | | | |
|------------------------------|--|-----|------|-------------------------|----|-----|--|
| | Flexible cords | | | Cables for fixed wiring | | | |
| # 3 | 0,5 | and | 0,75 | 1 | to | 2,5 | |
| > 3 and # 6 | 0,75 | and | 1 | 1 | to | 2,5 | |
| > 6 and # 10 | 1 | and | 1,5 | 1 | to | 2,5 | |
| > 10 and # 16 | 1,5 | and | 2,5 | 1,5 | to | 4 | |
| > 16 and # 25 | 2,5 | and | 4 | 2,5 | to | 6 | |
| > 25 and # 32 | 4 | and | 6 | 4 | to | 10 | |
| > 32 and # 40 | 6 | and | 10 | 6 | to | 16 | |
| > 40 and # 63 | 10 | and | 16 | 10 | to | 25 | |

26.3 Terminals for the SUPPLY CORD shall be suitable for their purpose. Terminals with screw clamping and screwless terminals shall not be used for the connection of the conductors of flat twin tinsel cords unless the ends of the conductors are fitted with a device suitable for use with screw terminals.

Compliance is checked by inspection and by applying a pull of 5 N to the connection.

After the test, the connections shall show no damage which could impair compliance with this standard.

26.4 Terminals for TYPE X ATTACHMENT and those for connection to fixed wiring shall be fixed so that when the clamping means is tightened or loosened

- the terminal does not loosen;
- internal wiring is not subjected to stress;
- CREEPAGE DISTANCES and CLEARANCES are not reduced below the values specified in 29.1.

Compliance is checked by inspection and by the test of subclause 8.6 of IEC 60999-1, the torque applied being equal to two-thirds of the torque specified.

NOTES

1 Terminals may be prevented from loosening by fixing with two screws, by fixing with one screw in a recess such that there is no appreciable movement, or by other suitable means.

2 Covering with sealing compound without other means of locking is not considered to be sufficient. However self-hardening resins may be used to lock terminals which are not subject to torsion in normal use.

26.5 Terminals for TYPE X ATTACHMENT and for connection to fixed wiring shall be constructed so that they clamp the conductor between metal surfaces with sufficient contact pressure and without damaging the conductor.

Compliance is checked by inspection of the terminals and of the conductors, after the test of 26.4.

26.6 Terminals for TYPE X ATTACHMENT, except those connected to a specially prepared cord, and terminals for connection to fixed wiring, shall not require special preparation of the conductor. They shall be constructed or placed so that the conductor cannot slip out when clamping screws or nuts are tightened.

Compliance is checked by inspection of the terminals and of the conductors after the test of 26.4.

NOTES

1 The term "special preparation of the conductor" covers soldering of the strands, the use of cable lugs, eyelets or similar devices, but not the reshaping of the conductor before its introduction into the terminal or the twisting of a stranded conductor to consolidate the end.

2 Conductors are considered to be damaged if they show deep or sharp indentations.

26.7 Terminals of the pillar type shall be constructed and located so that the end of a conductor introduced into the hole is visible or can pass beyond the threaded hole for a distance at least equal to half the nominal diameter of the screw or 2,5 mm, whichever is the greater.

Compliance is checked by inspection and by measurement.

26.8 Terminals, including the earthing terminal, for the connection to fixed wiring shall be located close to each other.

Compliance is checked by inspection.

26.9 Terminals for TYPE X ATTACHMENT shall be accessible after removal of a cover or part of the enclosure.

Compliance is checked by inspection.

26.10 Terminals shall only be accessible after removal of a NON-DETACHABLE PART.

Compliance is checked by inspection and by manual test.

26.11 Terminals for TYPE X ATTACHMENT shall be located or shielded so that if a wire of a stranded conductor escapes when the conductors are fitted, there is no risk of accidental connection between LIVE PARTS and accessible metal parts and for CLASS II CONSTRUCTION, between LIVE PARTS and metal parts separated from accessible metal parts by SUPPLEMENTARY INSULATION only.

Compliance is checked by inspection and by the following test.

A 8 mm length of insulation is removed from the end of a flexible conductor having a nominal cross-sectional area as specified in table 9.

One wire of the stranded conductor is left free and the other wires are fully inserted and clamped in the terminal.

The free wire is bent, without tearing the insulation back, in every possible direction but without making sharp bends around barriers.

NOTE – The test is also applied to earthing conductors.

27 Provision for earthing

27.1 Accessible metal parts of CLASS 0I AND CLASS I APPLIANCES which may become live in the event of an insulation fault, shall be permanently and reliably connected to an earthing terminal within the appliance or to the earthing contact of the appliance inlet.

Earthing terminals and earthing contacts shall not be connected to the neutral terminal.

CLASS 0, CLASS II AND CLASS III APPLIANCES shall have no provision for earthing.

Compliance is checked by inspection.

NOTES

1 If accessible metal parts are screened from LIVE PARTS by metal parts which are connected to the earthing terminal or to the earthing contact, they are not regarded as likely to become live in the event of an insulation fault.

2 Metal parts behind a decorative cover which does not withstand the test of clause 21 are considered to be accessible metal parts.

27.1DV D2 Add the following paragraph after the first paragraph of 27.1:

In service access areas, where conductive parts such as motor frames, electronic chassis, etc., might attain a hazardous voltage in the event of a single fault, either these conductive parts shall be connected to the main protective earthing terminal or, a warning label shall indicate to service personnel that such parts are not earthed and should be checked for hazardous voltage before being touched.

27.2 Terminals for the connection of external equipotential bonding conductors shall allow the connection of conductors having nominal cross-sectional areas of 2,5 mm² to 6 mm² and shall not be used to provide earthing continuity between different parts of the appliance. It shall not be possible to loosen the conductors without the aid of a TOOL.

The clamping means of earthing terminals shall be adequately secured against accidental loosening.

Compliance is checked by inspection, and by manual test.

NOTES

1 The earthing conductor in a SUPPLY CORD is not considered to be an equipotential bonding conductor.

2 In general, the constructions commonly used for current-carrying terminals, other than some terminals of the pillar type, provide sufficient resiliency to comply with the latter requirement. For other constructions, special provisions, such as the use of an adequately resilient part which is not likely to be removed inadvertently, may be necessary.

27.2DV D1 Deletion:**Delete 27.2. See 27.5DV**

27.3 If a DETACHABLE PART is plugged into another part of the appliance and has an earth connection, this connection shall be made before the current-carrying connections are established when placing the part in position and the current-carrying connections shall be separated before the earth connection is broken when removing the part.

For appliances with SUPPLY CORDS, the arrangement of the terminals or the length of the conductors between the cord anchorage and the terminals, shall be such that the current-carrying conductors become taut before the earthing conductor if the cord slips out of the cord anchorage.

Compliance is checked by inspection and by manual test.

27.4 All parts of the earthing terminal intended for the connection of external conductors shall be such that there is no risk of corrosion resulting from contact between these parts and the copper of the earthing conductor or any other metal in contact with these parts.

Parts provided earthing continuity, other than parts of a metal frame or enclosure shall be of coated or uncoated metal having adequate resistance to corrosion. If such parts are of steel, they shall be provided at the essential areas with an electroplated coating having a thickness of at least 5µm.

Parts of coated or uncoated steel which are only intended to provide or to transmit contact pressure shall be adequately protected against rusting.

If the body of the earthing terminal is a part of a frame or enclosure of aluminum or aluminum alloy, precautions shall be taken to avoid the risk of corrosion resulting from contact between copper and aluminum or its alloys.

Compliance is checked by inspection and by measurement.

NOTES

1 Parts of copper or copper alloys containing at least 58% copper for parts that are worked cold and at least 50% copper for other parts and parts of stainless steel containing at least 13% chrome, are considered to be sufficiently resistant to corrosion.

2 Parts subjected to a treatment such as chromate conversion coating are in general not considered to be adequately protected against corrosion, but they may be used to provide or to transmit contact pressure.

3 Examples of parts providing earthing continuity and parts which are only intended to provide or to transmit contact pressure are shown in figure 14.

4 The essential areas of steel parts are, in particular, those liable to transmit a fault current. In evaluating such areas, the thickness of the coating in relation to the shape of the part has to be taken into account. In case of doubt, the thickness of the coating is measured as described in ISO 2178 or in ISO 1463.

27.5 The connection between the earthing terminal or earthing contact and earthed metal parts shall have low resistance.

Compliance is checked by the following test.

A current derived from a source having a no-load voltage not exceeding 12 V (a.c. or d.c.) and equal to 1,5 times RATED CURRENT of the appliance or 25 A, whichever is the greater, is passed between the earthing terminal or earthing contact and each of the accessible metal parts in turn.

The voltage drop between the earthing terminal of the appliance or the earthing contact of the appliance inlet and the accessible metal part is measured. The resistance calculated from the current of this voltage drop shall not exceed 0,1 S.

NOTES

1 In case of doubt, the test is carried out until steady conditions have been established.

2 The resistance of the SUPPLY CORD is not included in the measurement.

3 Care is taken to insure that the contact resistance between the tip of the measuring probe and the metal part under test does not influence the test results.

27.5DV D1 Replacement of 27.5 and 27.2 with 27.5 DV.1 through 27.5DV.15:

27.5DV.1 The requirements of 27.5DV.2 – 27.5DV.4 apply to protective earthing conductors and protective bonding conductors provided to comply with 27.1.

27.5DV.2 Size of PROTECTIVE EARTHING CONDUCTORS

27.5DV.2.1 PROTECTIVE EARTHING CONDUCTORS shall at least be of the same size as supply conductors and shall comply with the minimum conductor sizes of column A of table 27.5DV.2.1.1

27.5DV.2.2 Compliance is checked by inspection and measurement.

Table 27.5DV.2.1.1 D1 Addition:**Table 27.5DV.2.1.1 – Minimum size of protective conductors (see 27.5DV.1 and 27.5DV.2)**

| RATED CURRENT of the equipment under consideration | Minimum conductor sizes AWG | |
|--|------------------------------------|-----------------------------------|
| | A PROTECTIVE EARTHING CONDUCTOR | B PROTECTIVE BONDING CONDUCTOR |
| Amperes | | |
| Up to and including 10 | 18 | 20 |
| Over 10 up to and including 13 | 16 | 18 |
| Over 13 up to and including 18 | 14 | 16 |
| Over 18 up to and including 25 | 12 | 14 |
| Over 25 up to and including 30 | 10 | 12 |
| Over 30 up to and including 40 | 8 | 10 |
| Over 40 up to and including 55 | 6 | 8 |
| Over 55 up to and including 70 | 4 | 6 |
| Over 70 up to and including 95 | 2 | 4 |

27.5DV.3 Size of PROTECTIVE BONDING CONDUCTORS

27.5DV.3.1 PROTECTIVE BONDING CONDUCTORS shall comply with one of the following:

- the minimum conductor sizes in column A of table 27.5DV.2.1.1; or
- for components only, be not smaller than the conductors supply power to the component.

27.5DV.3.2 If the PROTECTIVE BONDING CONDUCTOR is smaller than the conductor supplying power then the protective bonding conductor shall comply with:

- the requirements of 27.5DV.5 and 27.5DV.6 and also, with the minimum conductor sizes in column B of table 27.5DV.2.1.1; or
- the requirements of 27.5DV.5 – 27.5DV.7 if the conductor size is smaller than the conductor size in column B of table 27.5DV.2.1.1.

27.5DV.4 The current rating of the circuit used in table 27.5DV.7.1.1 and the tests of 27.5NA.6 and 27.5DV.7 depends on the provision and location of the overcurrent PROTECTIVE DEVICES and shall be the smallest of the following:

- the current rating of the attachment plug but not less than 20 A; or
- the rating of an overcurrent PROTECTIVE DEVICE specified by the manufacturer to be installed in the building installation wiring to protect the equipment; or
- the rating of an overcurrent PROTECTIVE DEVICE in the equipment that protects the circuit or part required to be earthed.

27.5DV.4.1 Compliance is checked by inspection and measurement.

27.5DV.5 Resistance of earthing conductors and their terminations

27.5DV.5.1 Earthing conductors and their terminations shall not have excessive resistance as determined by the impedance test of 27.5DV.6.

27.5DV.5.2 PROTECTIVE EARTHING CONDUCTORS are considered to comply without test.

27.5DV.5.3 PROTECTIVE BONDING CONDUCTORS that meet the minimum conductor sizes in column A of table 27.5DV.2.1.1 and are terminated in accordance with table 27.5DV.9.3.1 are considered to comply without test.

27.5DV.5.4 Compliance is checked by inspection, measurement and, for PROTECTIVE BONDING CONDUCTORS that do not comply with the minimum sizes in column A but comply with the minimum sizes in column B of table 27.5DV.2.1.1 and for protective bonding terminals that do not comply with table 27.5DV.9.3.1, by the impedance test of 27.5DV.6.

27.5DV.5.5 For PROTECTIVE BONDING CONDUCTORS that do not comply with the minimum sizes in column B of table 27.5DV.2.1.1 and for protective bonding terminals that do not comply with table 27.5DV.9.3.1, by the limited short circuit test of 27.5DV.7.

27.5DV.6 Impedance test

27.5DV.6.1 The voltage drop in a PROTECTIVE BONDING CONDUCTOR is measured after it has conducted a test current of 2 times the current rating (see 27.5DV.4) of the circuit for 2 min. The test current can be either a.c. or d.c. The measurement is made between the main protective earthing terminal and the point in the equipment that is required by 27.1 to be earthed. The resistance of the PROTECTIVE EARTHING CONDUCTOR is not included in the measurement. However, if the PROTECTIVE EARTHING CONDUCTOR is supplied with the equipment, it is permitted to be included in the test circuit but the measurement of the voltage drop is made only from the main protective earthing terminal to the part required to be earthed.

27.5DV.6.2 The voltage drop across the PROTECTIVE BONDING CONDUCTOR shall not exceed 2,5 V.

27.5DV.7 D1 Limited short circuit test

27.5DV.7.1 The protective earthing path is connected to the supply circuit having a capacity in accordance with table 27.5DV.7.1.1. The capacity is determined without the protective earthing path in the circuit. The supply voltage is the nominal voltage of the a.c. mains supply. An overcurrent PROTECTIVE DEVICE rated no more than the current rating of 27.5DV.4 is connected in series with the protective earthing path.

Table 27.5DV.7.1.1 D1 *Addition*:

Table 27.5DV.7.1.1: Short circuit capacity for the limited short circuit test (see 27.5DV.7)

| Maximum rating of the appliance | | | Horsepower (W) | Volts | Circuit capacity in amperes |
|---------------------------------|----------------------|-----------------------------|-------------------------|-----------|-----------------------------|
| Volt-amperes single-phase | Volt-amperes 3-phase | Volt-amperes direct current | | | |
| 0 – 1176 | 0 – 832 | 0 – 648 | 0,5 max (373) | 0 – 250 | 200 |
| 0 – 1176 | 0 – 832 | 0 – 648 | 0,5 max (373) | 251 – 600 | 1000 |
| 1177 – 1920 | 833 – 1496 | 649 – 1140 | >0,5 (373) to 1 (746) | 0 – 600 | 1000 |
| 1921 – 4080 | 1497 – 3990 | 1141 – 3000 | >1 (746) to 3 (2200) | 0 – 250 | 2000 |
| 4081 – 9600 | 3991 – 9145 | 3001 – 6960 | >3 (2200) to 7,5 (5600) | 0 – 250 | 3500 |
| 9601 or higher | 9146 or higher | 6961 or higher | > 7,5 (5600) | 0 – 250 | 5000 |
| 1921 or higher | 1497 or higher | 1141 or higher | > 1 (746) | 251 – 600 | 5000 |

27.5DV.7.2 During the test, the protective earthing path shall not open and there shall be no damage to any insulation, the failure of which would result in contact between the earth path and a LIVE PART. The integrity of the insulation is checked by the electric strength of 16.1 by applying the test between LIVE PARTS and earthed parts.

27.5DV.8 Colour of insulation

27.5DV.8.1 The insulation of the PROTECTIVE EARTHING CONDUCTOR in a POWER SUPPLY CORD supplied with the equipment shall be green or green/yellow.

27.5DV.8.2 If a PROTECTIVE BONDING CONDUCTOR is insulated and visible from the field wiring compartment, the insulation shall be green or green/yellow except in the following two cases:

- for an earthing braid, the insulation shall be either green or green/yellow or transparent;
- for a PROTECTIVE BONDING CONDUCTOR in assemblies such as ribbon cables, busbars, printed wiring, etc., any colour is permitted provided that no misinterpretation of the use of the conductor is likely to arise.

27.5DV.8.3 The colour green or colour combination green/yellow shall be used only to identify PROTECTIVE EARTHING CONDUCTORS OR PROTECTIVE BONDING CONDUCTORS.

27.5DV.8.4 Compliance is checked by inspection.

27.5DV.9 Protective earthing terminals

27.5DV.9.1 Equipment required to have protective earthing shall have a main protective earthing terminal. For permanently connected equipment, a pigtail lead not shorter than 150 mm and not smaller than 18 AWG is permitted. For equipment with a DETACHABLE CORD, the earthing terminal in the appliance inlet is regarded as the main protective earthing terminal.

27.5DV.9.2 Terminals shall resist loosening of the conductor.

27.5DV.9.3 Except as noted below, all pillar, stud or screw type protective earthing and protective bonding terminals shall comply with the minimum size requirements of table 27.5DV.9.3.1.

27.5DV.9.4 Protective bonding terminals which do not comply with table 27.5DV.9.3.1 are considered acceptable if they meet the requirements of 27.5DV.5.

27.5DV.9.5 The main protective earthing terminal for permanently connected equipment shall be:

- located so that it is readily accessible while making the supply connections; and
- provided with factory installed studs, screws, or bolts, together with the necessary hardware if requiring a PROTECTIVE EARTHING CONDUCTOR larger than 7 mm² (3 mm diameter).

27.5DV.9.6 Compliance is checked by inspection, and measurement.

Table 27.5DV.9.3.1 D1 Addition:

Table 27.5DV.9.3.1: Sizes of terminals for PROTECTIVE EARTHING CONDUCTORS (see 27.5DV.9)

| RATED CURRENT of equipment A | Minimum nominal thread diameter mm | |
|---------------------------------|------------------------------------|------------|
| | Pillar type or stud type | Screw type |
| Up to and including 10 | 3,0 | 3,5 |
| Over 10 up to and including 16 | 3,5 | 4,0 |
| Over 16 up to and including 25 | 4,0 | 5,0 |
| Over 25 up to and including 32 | 4,0 | 5,0 |
| Over 32 up to and including 40 | 5,0 | 5,0 |
| Over 40 up to and including 63 | 6,0 | 6,0 |

27.5DV.10 Separation of the PROTECTIVE EARTHING CONDUCTOR from PROTECTIVE BONDING CONDUCTORS

27.5DV.10.1 A separate wiring terminal or a pigtail lead shall be provided for the PROTECTIVE EARTHING CONDUCTOR.

27.5DV.10.2 It is permitted to provide a single wiring terminal in equipment with an appliance inlet.

27.5DV.10.3 Compliance is checked by inspection.

27.5DV.11 Interconnection of equipment

27.5DV.11.1 In a system of interconnected equipment, the protective earthing connection shall be provided for all equipment requiring a protective earthing connection, regardless of the arrangement of equipment in the system.

27.5DV.11.2 Equipment that contains a PROTECTIVE BONDING CONDUCTOR to maintain continuity of protective earthing circuits to other equipment in the system, shall not be marked with the symbol (IEC 60417-1 No. 5172).



27.5DV.11.3 Such equipment shall also provide power to the other equipment in the system.

27.5DV.11.4 Protective earthing connections shall be such that disconnection of a protective earth at one point in a unit or a system does not break the protective earthing connection to other parts or units in a system, unless the potential hazard is removed at the same time.

27.5DV.11.5 *Compliance is check by inspection.*

27.5DV.12 Components in PROTECTIVE EARTHING CONDUCTORS and PROTECTIVE BONDING CONDUCTORS

27.5DV.12.1 PROTECTIVE EARTHING CONDUCTORS and PROTECTIVE BONDING CONDUCTORS shall not contain switches or overcurrent PROTECTIVE DEVICES.

27.5DV.12.2 *Compliance is checked by inspection.*

27.5DV.13 Parts that can be removed by an operator

27.5DV.13.1 Protective earthing connections shall make earlier and break later than the supply connections.

27.5DV.13.2 *Compliance is checked by inspection.*

27.5DV.14 Parts removed during servicing

27.5DV.14.1 Protective earthing connections shall be so constructed that they do not have to be disconnected for servicing other than for the removal of the part which they protect unless the potential hazard is removed at the same time.

27.5DV.14.2 *Compliance is checked by inspection.*

27.5DV.15 Screws for protective bonding

27.5DV.15.1 Self tapping (thread-cutting and thread-forming) and spaced thread (sheet metal) screws are permitted to provide continuity for protective earthing but it shall not be necessary to disturb the connection during servicing.

27.5DV.15.2 In any case, the thickness of the metal part at the point where a screw is threaded into it shall not be less than twice the pitch of the screw thread. It is permitted to use local extrusion of a metal part to increase the effective thickness.

27.5DV.15.3 At least two screws shall be used for each connection. However, it is permitted to use a single self-tapping screw provided that the thickness of the metal part at the point where the screw is threaded into it is a minimum of 0,9 mm for a screw of the thread-forming type and 1,6 mm for a screw of the thread-cutting type.

27.5DV.15.4 *Compliance is checked by inspection.*

27.6 The printed conductors of printed circuit boards shall not be used to provide earthing continuity in HAND-HELD APPLIANCES. They may be used to provide earthing continuity in other appliances if

- at least two tracks are used with independent soldering points and the appliance complies with 27.5 for each circuit;
- the material of the printed circuit board complies with IEC 60249-2-4 or IEC 60249-2-5.

Compliance is checked by inspection and by the relevant tests.

28 Screws and connections

28.1 Fixings, the failure of which may impair compliance with this standard, electrical connections, and connection providing earthing continuity shall withstand the mechanical stresses occurring in normal use.

Screws used for these purposes shall not be of metal which is soft or liable to creep, such as zinc or aluminum. If they are of insulating material they shall have a nominal diameter of at least 3 mm and they shall not be used for any electrical connection or connection providing earthing continuity.

Screws used for electrical connections or for connections providing earthing continuity shall screw into metal.

Screws shall not be of insulating material if their replacement by a metal screw could impair SUPPLEMENTARY INSULATION or REINFORCED INSULATION. Screws which may be removed when replacing a SUPPLY CORD having a TYPE X ATTACHMENT or when undertaking USER MAINTENANCE shall not be of insulating material if their replacement by a metal screw could impair BASIC INSULATION.

Compliance is checked by inspection and by the following test.

Screws and nuts are tested if they

- are used for electrical connections;
- are used for connections providing earthing continuity, unless at least two screws or nuts are used;
- are likely to be tightened
 - ! during USER MAINTENANCE;
 - ! when replacing a SUPPLY CORD having a TYPE X ATTACHMENT;
 - ! during installation.

The screws or nuts are tightened and loosened without jerking:

- 10 times for screws in engagement with a thread of insulating material;
- 5 times for nuts and other screws.

Screws in engagement with a thread of insulating material are completely removed and reinserted each time.

When testing terminal screws and nuts, a cable or flexible cord of the largest cross-sectional area specified in table 11 is placed in the terminal. It is repositioned before each tightening.

The test is made by means of a suitable screwdriver, spanner or key and by applying a torque as shown in table 12.

Column I is applicable for metal screws without heads if the screw does not protrude from the hole when tightened.

Column II is applicable

– for other metal screws and for nuts;

– for screws of insulating material

- having a hexagonal head with the dimension across flats exceeding the overall thread diameter;*
- with a cylindrical head and a socket for a key, the socket having a cross-corner dimension exceeding the overall thread diameter;*
- with a head having a slot or cross slots, the length of which exceeds 1,5 times the overall thread diameter.*

Column III is applicable for other screws of insulating material.

No damage impairing the further use of the fixings or connections shall occur.

NOTES

1 Space-threaded (sheet metal) screws having a nominal diameter of 2,9 mm are considered to be equivalent to screws having a metric ISO thread of 3 mm diameter.

2 The shape of the blade of the screwdriver is to fit the head of the screw.

Table 12 – Torque for testing screws and nuts

| Nominal diameter of screw (outer thread diameter) mm | | | Torque Nm | | |
|--|-----|------|-----------|-----|------|
| | | | I | II | III |
| | | #2,8 | 0,2 | 0,4 | 0,4 |
| >2,8 | and | #3,0 | 0,25 | 0,5 | 0,5 |
| >3,0 | and | #3,2 | 0,3 | 0,6 | 0,5 |
| >3,2 | and | #3,6 | 0,4 | 0,8 | 0,6 |
| >3,6 | and | #4,1 | 0,7 | 1,2 | 0,6 |
| >4,1 | and | #4,7 | 0,8 | 1,8 | 0,9 |
| >4,7 | and | #5,3 | 0,8 | 2,0 | 1,0 |
| >5,3 | | | – | 2,5 | 1,25 |

28.2 Electrical connections and connections providing earthing continuity shall be constructed so that contact pressure is not transmitted through insulating material which is liable to shrink or to distort unless there is sufficient resiliency in the metallic parts to compensate for any possible shrinkage or distortion of the insulating material. This requirement does not apply to electrical connections in circuits carrying a current to exceeding 0,5 A.

Compliance is checked by inspection.

NOTE – Ceramic material is not liable to shrink or to distort.

28.3 Space-threaded (sheet metal) screws shall not be used for electrical connections, unless they clamp these parts directly in contact with each other.

Thread-cutting (self-tapping) screws shall not be used for electrical connections, unless they generate a full form standard machine screw thread. Such screws shall not be used if they are likely to be operated by the user or installer unless the thread is formed by a swaging action.

Thread-cutting and space-threaded screws may be used in connections providing earthing continuity, provided that it is not necessary to disturb the connection in normal use and that at least two screws are used for each connection.

Compliance is checked by inspection.

28.4 Screws and nuts which make a mechanical connection between different parts of the appliance shall be secured against loosening if they also make electrical connections or connections providing earthing continuity.

NOTES

- 1 This requirement does not apply to screws in the earthing circuit if at least two screws are used for the connection or if an alternative earthing circuit is provided.
- 2 Spring washers, lock washers and crown type locks as part of the screw head are means which may provide satisfactory security.
- 3 Sealing compound which softens on heating provides satisfactory security only for screw connections not subject to torsion in normal use.

Rivets used for electrical connections or for connections providing earthing continuity shall be secured against loosening if these connections are subject to torsion in normal use.

NOTES

- 4 This requirement does not imply that more than one rivet is necessary for providing earthing continuity.
- 5 A non-circular shank or an appropriate notch may be sufficient.

Compliance is checked by inspection and by manual test.

29 CREEPAGE DISTANCES, CLEARANCES and distances through insulation

29.1 CREEPAGE DISTANCES and CLEARANCES shall not be less than the values in millimetres shown in table 13.

If a resonant voltage occurs between the point where a winding and a capacitor are connected together and metal parts are separated from LIVE PARTS by BASIC INSULATION only, CREEPAGE DISTANCES and CLEARANCES shall not be less than the values specified for the value of the voltage produced by the resonance, these values being increased by 4 mm in the case of REINFORCED INSULATION.

Compliance is checked by measurement.

For appliances provided with an appliance inlet, the measurements are made with an appropriate connector inserted. For appliances with TYPE X ATTACHMENT other than those having a specially prepared cord, they are made with supply conductors of the largest cross-sectional area specified in table 11 and also without conductors. For other appliances, they are made on the appliance as delivered.

For appliances provided with belts, the measurements are made with the belts in place and any device intended for varying the belt tension adjusted to the most unfavourable position within its range of adjustment and also with the belts removed.

Movable parts are placed in the most unfavourable position. Nuts and screws with non-circular heads are assumed to be tightened in the most unfavourable position.

The CLEARANCES between terminals and accessible metal parts are also measured with the screws or nuts unscrewed as far as possible but the CLEARANCES shall then be not less than 50% of the values shown in table 13.

Distances through slots or openings in external parts of insulating material are measured to metal foil in contact with the accessible surface. The foil is pushed into corners and similar locations by means of the test finger of figure 1 but it is not pressed into openings.

If necessary, a force is applied to any point on bare conductors, other than those of heating elements, to any point on uninsulated metal capillary tubes of THERMOSTATS and similar devices and to the outside of metal enclosures, in an endeavor to reduce the CREEPAGE DISTANCE and CLEARANCE while taking the measurements.

The force is applied by means of a test finger of figure 1 and has a value of

– 2 N for bare conductors, uninsulated capillary tubes of THERMOSTATS, conductive hoses, metal foil within the appliance and similar parts.

– 30 N for enclosures.

NOTES

1 Methods of measuring CREEPAGE DISTANCES and CLEARANCES are indicated in annex E.

2 CLEARANCES are measured over barriers. If the barrier is in two parts which are not cemented together, CREEPAGE DISTANCES and CLEARANCES are measured through the joint.

3 For appliance having parts with DOUBLE INSULATION where there is no metal between BASIC INSULATION and SUPPLEMENTARY INSULATION, the measurements are made as though there is metal foil between the two insulations.

4 When assessing CREEPAGE DISTANCE and CLEARANCES, the effect of insulating linings of metal enclosures or covers is taken into consideration.

5 Means provided for fixing the appliance to a support are considered to be accessible.

6 The values specified in the table do not apply to cross-over points of motor windings.

For conductive patterns on printed circuit boards, except at their edges, the values in the table between parts of different potential may be reduced as long as the peak value of the voltage stress does not exceed

– 150 V per mm with a minimum distance of 0,2 mm, if protected against the deposition of dirt;

– 100 V per mm with a minimum distance of 0,5 mm, if not protected against the deposition of dirt.

For peak voltages exceeding 50 V, the reduced CREEPAGE DISTANCES only apply if the proof tracking index (PTI) of the printed circuit board is greater than 175 when measured in accordance with annex N.

These distances may be reduced further provided that the appliance complies with the requirements of clause 19 when the distances are short-circuited in turn.

NOTE 7 – When the limits specified above leads to higher values than those of the table, the values of the table apply.

CREEPAGE DISTANCES and CLEARANCES within optocouplers are not measured.

For LIVE PARTS of different potential separated by BASIC INSULATION only, CREEPAGE DISTANCES and CLEARANCES smaller than those specified in the table are allowed provided the requirements of clause 19 are met if these CREEPAGE DISTANCES and CLEARANCES are short-circuited in turn.

29.2 The distance through insulation between metal parts for WORKING VOLTAGES up to and including 250 V shall not be less than 1,0 mm if they are separated by SUPPLEMENTARY INSULATION and not be less than 2,0 mm if they are separated by REINFORCED INSULATION.

Compliance is checked by inspection and by measurement.

NOTES

1 This does not imply that the distance has to be through solid insulation only. The insulation may consist of solid material plus one or more air layers.

2 For appliances having parts with DOUBLE INSULATION where there is no metal between BASIC INSULATION and SUPPLEMENTARY INSULATION, the measurements are made as though there is a metal foil between the two insulations.

Table 13 – Minimum CREEPAGE DISTANCES and CLEARANCES (in millimetres)

| Distances | CLASS III APPLIANCES and CONSTRUCTIONS | | Other appliances | | | | | |
|--|--|-----------|------------------------|-----------|----------------------------------|-------------------|-----------------------------------|-----------|
| | | | WORKING VOLTAGE #130 V | | WORKING VOLTAGE >130 V and #250V | | WORKING VOLTAGE >250 V and #480 V | |
| | CREEPAGE DISTANCE | CLEARANCE | CREEPAGE DISTANCE | CLEARANCE | CREEPAGE DISTANCE | CLEARANCE | CREEPAGE DISTANCE | CLEARANCE |
| Between LIVE PARTS of different potential ¹⁾ | | | | | | | | |
| – if protected against deposition of dirt ²⁾ | 1,0 | 1,0 | 1,0 | 1,0 | 2,0 | 2,0 | 2,0 | 2,0 |
| – if not protected against deposition of dirt | 2,0 | 1,5 | 2,0 | 1,5 | 3,0 | 2,5 | 4,0 | 3,0 |
| – if lacquered or enamelled windings | 1,0 | 1,0 | 1,5 | 1,5 | 2,0 | 2,0 | 3,0 | 3,0 |
| – for positive temperature coefficient (PTC) resistors including their connecting wires, if protected against deposition of moisture or dirt ²⁾ | – | – | 1,0 | 1,0 | 1,0 | 1,0 | – | – |
| Between LIVE PARTS and other metal parts over BASIC INSULATION: | | | | | | | | |
| – if protected against deposition of dirt ²⁾ | | | | | | | | |
| • if of ceramic, pure mica and similar material | 1,0 | 1,0 | 1,0 | 1,0 | 2,5 ³⁾ | 2,5 ³⁾ | – | – |
| • if of other material | 1,5 | 1,0 | 1,5 | 1,0 | 3,0 | 2,5 ³⁾ | – | – |
| – if not protected against deposition of dirt | 2,0 | 1,5 | 2,0 | 1,5 | 4,0 | 3,0 | – | – |
| – if the LIVE PARTS are lacquered or enamelled windings | 1,0 | 1,0 | 1,5 | 1,5 | 2,0 | 2,0 | – | – |
| – at the end of tubular sheathed-type heating elements | – | – | 1,0 | 1,0 | 1,0 ⁵⁾ | 1,0 ⁴⁾ | – | – |
| Between LIVE PARTS and other metals parts over REINFORCED INSULATION: | | | | | | | | |
| – if the LIVE PARTS are lacquered or enamelled windings | – | – | 6,0 | 6,0 | 6,0 | 6,0 | – | – |
| – for other LIVE PARTS | – | – | 8,0 | 8,0 | 8,0 | 8,0 | – | – |

Table 13 (continued) – Minimum CREEPAGE DISTANCES and CLEARANCES

| | | | | | | | | |
|---|-----|-----|-----|-----|-----|-----|---|---|
| Between metal parts separated by SUPPLEMENTARY INSULATION | – | – | 4,0 | 4,0 | 4,0 | 4,0 | – | – |
| Between LIVE PARTS in recesses in the mounting face of the appliance and the surface to which it is fixed | 2,0 | 2,0 | 6,0 | 6,0 | 6,0 | 6,0 | – | – |

Notes to table 13

1) The CLEARANCE specified do not apply to the air gap between the contacts of automatic controls, switches of micro-gap construction and similar devices or to the air gap between the current-carrying members of such devices where the CLEARANCE varies with the movement of the contacts.

2) In general, the interior of an appliance having a reasonably dust-proof enclosure is considered to be protected against deposition of dirt, provided the appliance does not generate dust within itself; hermetic sealing is not required.

3) If the parts are rigid and located by moldings or if the construction is such that there is no likelihood of the distance being reduced by distortion or movement of the parts, this value may be reduced to 2,0 mm.

4) If protected against deposition of dirt.

5) If over ceramic, pure mica and similar materials, protected against deposition of dirt.

29.2.1 This requirement does not apply if the insulation is applied in thin sheet form, other than mica or similar scaly material and

- for SUPPLEMENTARY INSULATION, consists of at least two layers, provided that each of the layers withstands the electric strength test of 16.3 for SUPPLEMENTARY INSULATION;
- for REINFORCED INSULATION, consists of at least three layers, provided that any two layers together withstand the electric strength test of 16.3 for REINFORCED INSULATION.

Compliance is checked by inspection.

29.2.2 This requirement also does not apply if the SUPPLEMENTARY INSULATION or the REINFORCED INSULATION is inaccessible and meets one of the following conditions:

- the maximum temperature rise determined during the tests of clause 19 does not exceed the value specified in 11.8;
- the insulation, after having been conditioned 168 h in an oven maintained at a temperature equal to 50 K in excess of the maximum temperature rise determined during the tests of clause 19, withstands the electric strength test of 16.3, this test being made on the insulation both at the temperature occurring in the oven and after cooling to approximately room temperature.

Compliance is checked by inspection and by test.

For optocouplers the conditioning procedure is carried out at a temperature of 50 K in excess of the maximum temperature rise measured on the optocoupler during the tests of clauses 11 or 19, the optocoupler being operated under the most unfavourable conditions which occur during these tests.

30 Resistance to heat, fire and tracking

NOTE – The tests specified in this clause are based on the present IEC standards dealing with this subject. Other concepts for determining the resistance to fire, such as preselection testing, are under consideration.

Appendix H shows the selection and sequence of the tests of this clause.

30DV DC *Replace clause 30 with the following:*

30DV Parts made of polymeric materials shall comply with the requirements of the Standard for Polymeric Materials – Use in Electrical Equipment Evaluations UL 746C, as applicable to polymeric enclosures.

30.1 External parts of non-metallic material, parts of insulating material supporting LIVE PARTS including connections and parts of thermoplastic material providing SUPPLEMENTARY INSULATION or REINFORCED INSULATION, the deterioration of which might cause the appliance to fail to comply with this standard, shall be sufficiently resistant to heat.

Compliance is checked by subjecting the relevant part to the ball-pressure test made by means of the apparatus shown in figure 12.

Before starting the test, the part is maintained for 24 h in an atmosphere having a temperature between 15EC and 35EC and a relative humidity between 45% and 75%.

The part is supported so that its upper surface is horizontal and the spherical part of the apparatus is pressed against this surface with a force of 20 N. The thickness of the part under test shall be at least 2,5 mm.

NOTE 1 – If necessary, the required thickness may be obtained by using two or more sections of the part.

The test is made in a heating cabinet at a temperature of 40EC \pm 2EC plus the maximum temperature rise determined during the test of clause 11, but it shall be at least:

- | | |
|--|------------------------------------|
| <i>– for external parts</i> | <i>75 EC \pm 2EC</i> |
| <i>– for parts supporting LIVE PARTS</i> | <i>125 EC \pm 2EC</i> |

However, for parts of thermoplastic material providing SUPPLEMENTARY INSULATION or REINFORCED INSULATION, the test is made at a temperature of 25EC \pm 2EC plus the maximum temperature rise determined during the tests of clause 19, if this is higher. The temperature rises of 19.4 are not taken into account provided the test of 19.4 is terminated by the operation of a NON-SELF-RESETTING PROTECTIVE DEVICES and it is necessary to remove a cover or to use a TOOL to reset it.

Before the test is started, the test apparatus is brought to the temperature determined above.

After 1 h the apparatus is removed and the part is immediately immersed in cold water so that it is cooled to approximately room temperature within 10 s. The diameter of the impression shall not exceed 2 mm.

NOTES

2 For coil formers, only those parts which support or retain terminals in position are subjected to the test.

3 The test is not made on parts of ceramic material.

30.1DV DC Deletion of 30.1:

Delete 30.1 See 30DV.

30.2 Parts of non-metallic material shall be resistant to ignition and spread of fire.

This requirement does not apply to decorative trims, knobs and other parts not likely to be ignited or to propagate flames originating from inside the appliance.

Compliance is checked by the tests of 30.2.1, 30.2.4 and either 30.2.2 or 30.2.3 as applicable.

30.2DV DC Deletion of 30.2:**Delete 30.2 See 30DV.**

30.2.1 *Separately moulded samples of the relevant parts are subjected to the burning test of annex J. However, instead of the burning test, the glow-wire test of annex K is made at a temperature of 550EC on corresponding parts of the appliance if*

- separately moulded samples are not available;*
- there is no evidence that the material withstands the burning test;*
- the separately moulded samples do not withstand the burning test.*

30.2.1DV DC Deletion of 30.2.1:**Delete 30.2.1 See 30.1.**

30.2.2 *For appliances which are operated while attended, parts of insulating material supporting connections which carry a current exceeding 0,5 A during NORMAL OPERATION, are subjected to the glow-wire test of annex K, the test being made at a temperature of 650EC. This test is also carried out on parts in contact with, or in close proximity to, such connections.*

This test is not made on HAND-HELD APPLIANCES, on appliances which have to be kept switched on by hand or foot and on appliances which are continuously loaded by hand.

NOTES

- 1** The test is not carried out on parts supporting welded connections.
- 2** "In close proximity" is considered to be a distance not exceeding 3 mm.

30.2.2DV DC Deletion of 30.2.2:**Delete 30.2.2 See 30DV**

30.2.3 *For other appliances, connections supported by parts of insulating material and which carry a current exceeding 0,5 A during NORMAL OPERATION, are subjected to the bad-connection test of annex L. If this test cannot be made due to the design of the connection, the parts of insulating material supporting the connection are subjected to the glow-wire test of annex K, the test being made at a temperature of 750EC. In this case, the test is also carried out on parts in contact with, or in close proximity to, the connection.*

NOTES

- 1** The test is not carried out on parts supporting welded connections.
- 2** "In close proximity" is considered to be a distance not exceeding 3 mm.

During the application of the glow-wire, the height and duration of flames are measured.

In addition, for parts which withstand the glow-wire test but which flame during the application of the glow-wire, the surrounding parts are subjected to the needle-flame test of annex M for the measured duration of the flame if

- they are positioned within a distance equal to the height of the flame, and
- they are likely to be impinged upon by the flame.

However, parts shielded by a separate barrier which meets the needle-flame test are not tested.

The needle-flame test is not carried out on parts which are made of material classified as FV-0 or FV-1 according to IEC 60707. The sample of material submitted to the test of IEC 60707 shall be no thicker than the relevant part.

NOTE 3 – Parts likely to be impinged upon by the flame are considered to be those within the envelope of a vertical cylinder having a radius of 10 mm and a height equal to the height of the flame, positioned above the point of application of the glow-wire.

30.2.3DV DC Deletion of 30.2.3:

Delete 30.2.3 See 30DV

30.2.4 If the parts do not withstand the test of 30.2.2 or 30.2.3, the needle-flame test of annex M is made on all other parts of non-metallic material which are within a distance of 50 mm. However, parts shielded by a separate barrier which meets the needle-flame test are not tested.

The needle-flame test is not carried out on parts which are made of material classified as FV-0 or FV-1 according to IEC 60707. The sample of material submitted to the test of IEC 60707 shall be no thicker than the relevant part.

30.2.4DV DC Deletion of 30.2.4:

Delete 30.2.4. See 30DV

30.3 Insulating material across which a tracking path may occur shall have adequate resistance to tracking, taking into account the severity of the duty conditions.

A tracking path is liable to occur

- between LIVE PARTS of different potential;
- between LIVE PARTS and earthed metal parts;
- across insulating material of commutators and brush-caps.

Compliance is checked by the proof tracking test of annex N.

Parts of insulating material used under normal duty conditions and parts of ceramic material are not tested.

The test voltage is 175 V for parts of insulating material used under severe duty conditions. If the material does not withstand this test and there is no hazard other than fire, surrounding parts are subjected to the needle-flame test of annex M.

The test voltage is 250 V for parts of insulating material used under extra-severe duty conditions. If the material does not withstand this test, but withstands the test with a test voltage of 175 V and there is no hazard other than fire, the surrounding parts are subjected to the needle-flame test of annex M.

The needle-flame test is not carried out on parts which are made of material classified as FV-0 or FV-1 according to IEC 60707. The sample of material submitted to the test of IEC 60707 shall be no thicker than the relevant part.

NOTES

1 The needle-flame test is made on parts of non-metallic material within a distance of 50 mm from any place where a tracking path could occur. However parts shielded by a separate barrier which meets the needle-flame test are not tested.

2 The severity of the duty conditions of insulating material is given in annex P.

30.3DV DC *Deletion of 30.3:*

Delete 30.3. See 30DV

31 Resistance to rusting

Ferrous parts, the rusting of which might cause the appliance to fail to comply with this standard, shall be adequately protected against rusting.

NOTE – Tests are specified in part 2 when necessary.

32 Radiation, toxicity, and similar hazards

Appliances shall not emit harmful radiation or present a toxic or similar hazard.

NOTE – Tests are specified in part 2 when necessary.

Figure 1 – Test finger

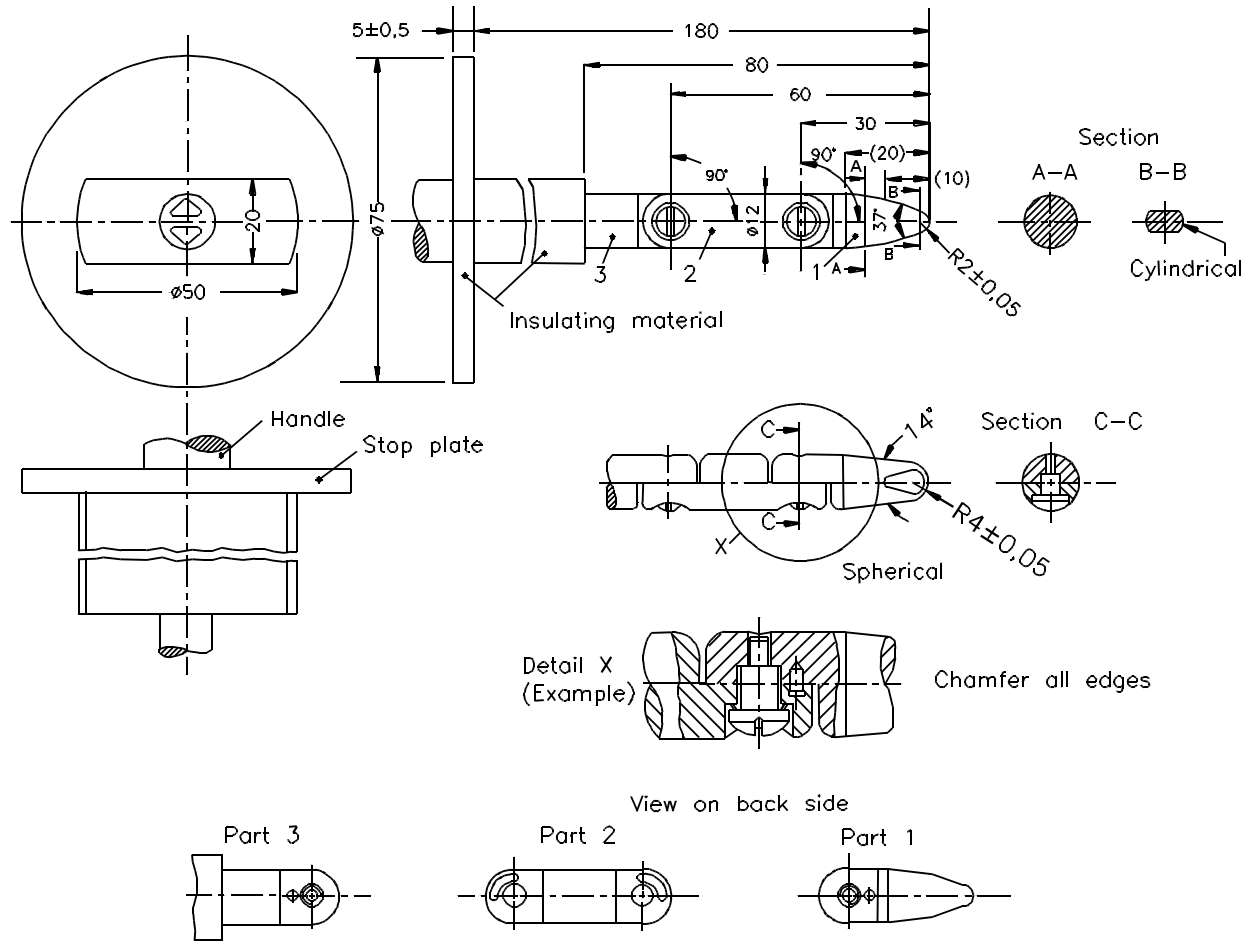

SM471B

Material: metal, except where otherwise specified

Linear dimensions in millimeters

Tolerances on dimensions without specific tolerance:

- on angles: 0/-10
- on linear dimensions:
- up to 25 mm: 0/-0,05
- over 25 mm: ± 0,2

Both joints shall permit movement in the same plane and the same direction through an angle of 90E with a 0 to + 10E tolerance

Figure 1DV D1 Replacement of Figure 1 (see clauses 1DV.1, 8.1.1DV, 20.2DV):
Figure 1DV – Articulate Probe with Web Stop

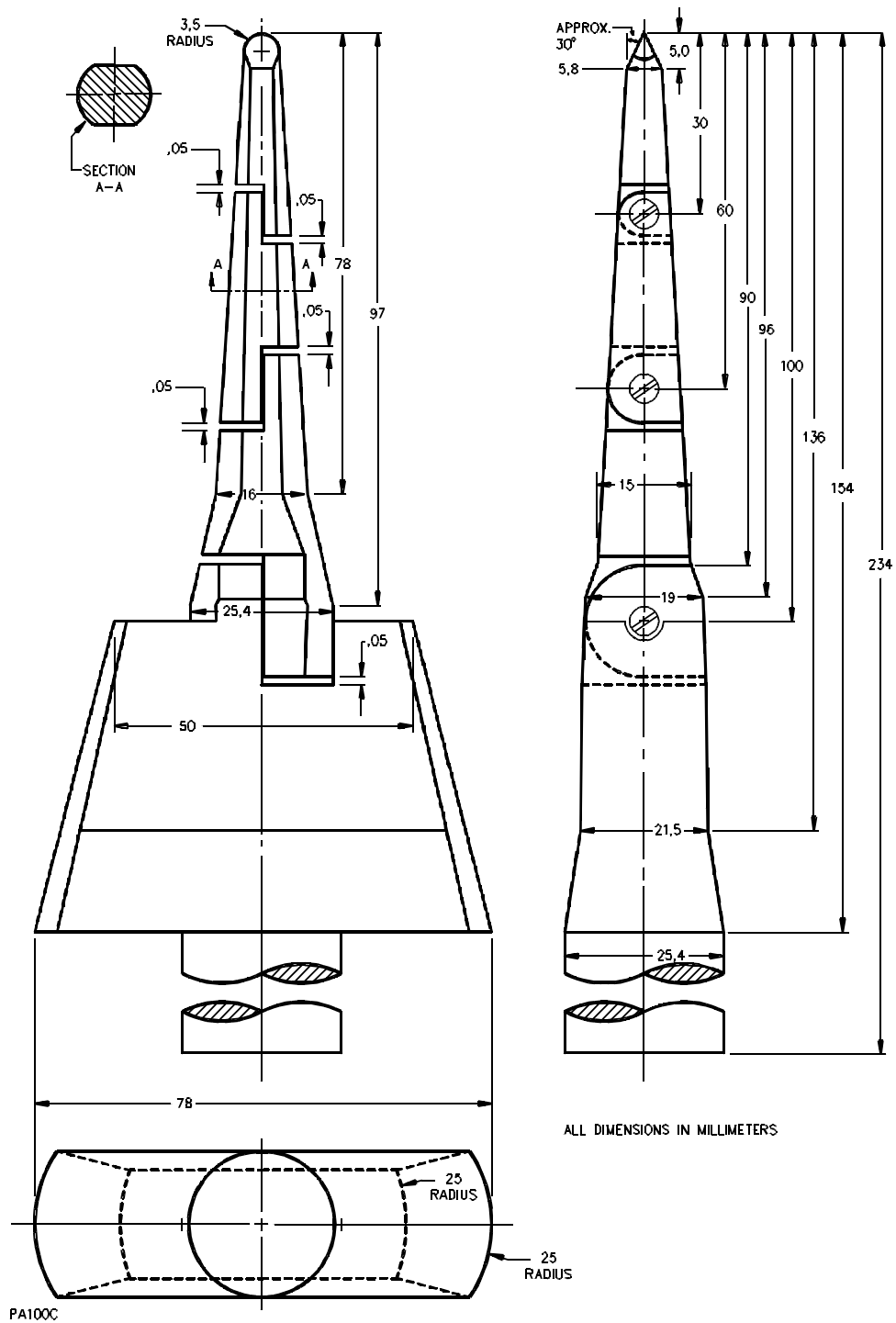
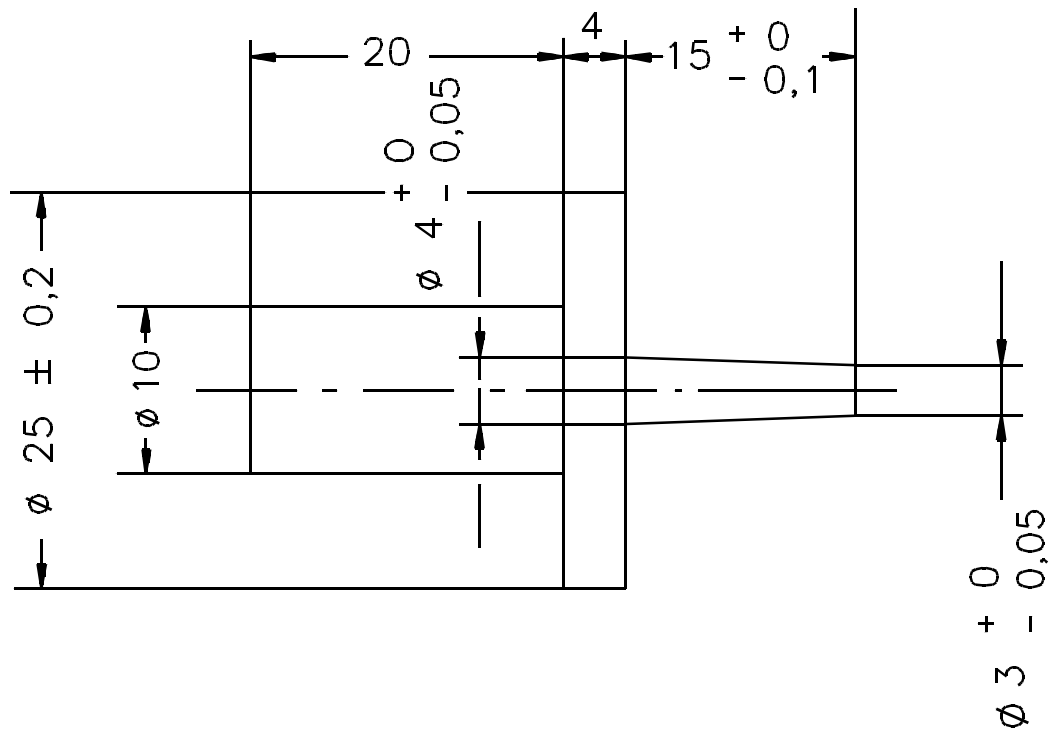

Figure 2 – Test pin



S3750A

Dimensions in millimeters

Figure 3 – Test probe

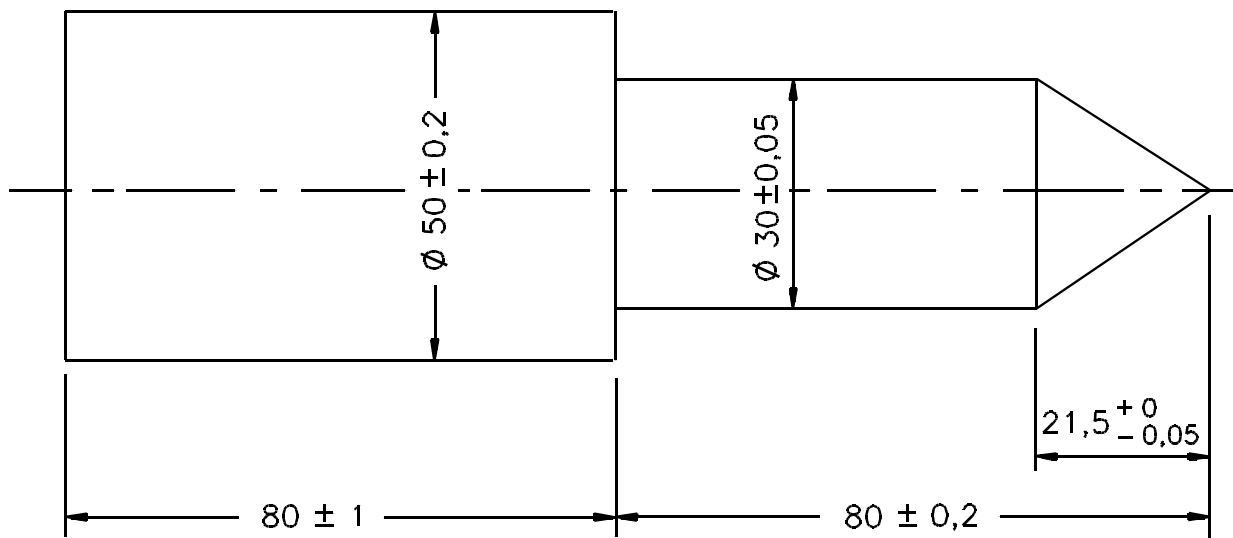

S3751A

Dimensions in millimeters

Figure 4 – Diagram for leakage current measurement at operating temperature for single-phase connection of CLASS II APPLIANCES

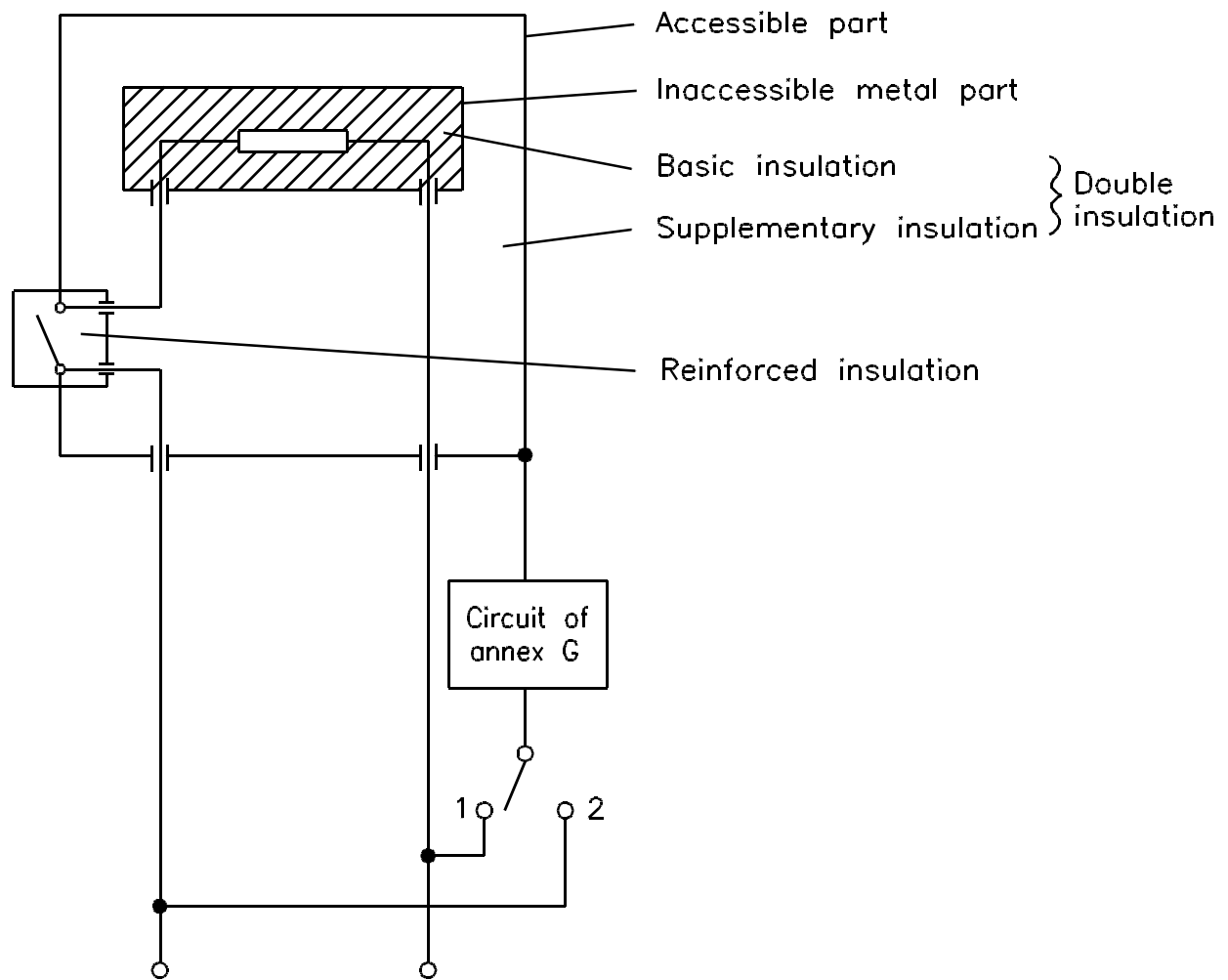

SM451A

Figure 5 – Diagram for leakage current measurement at operating temperature for single-phase connection of appliances other than those of CLASS II

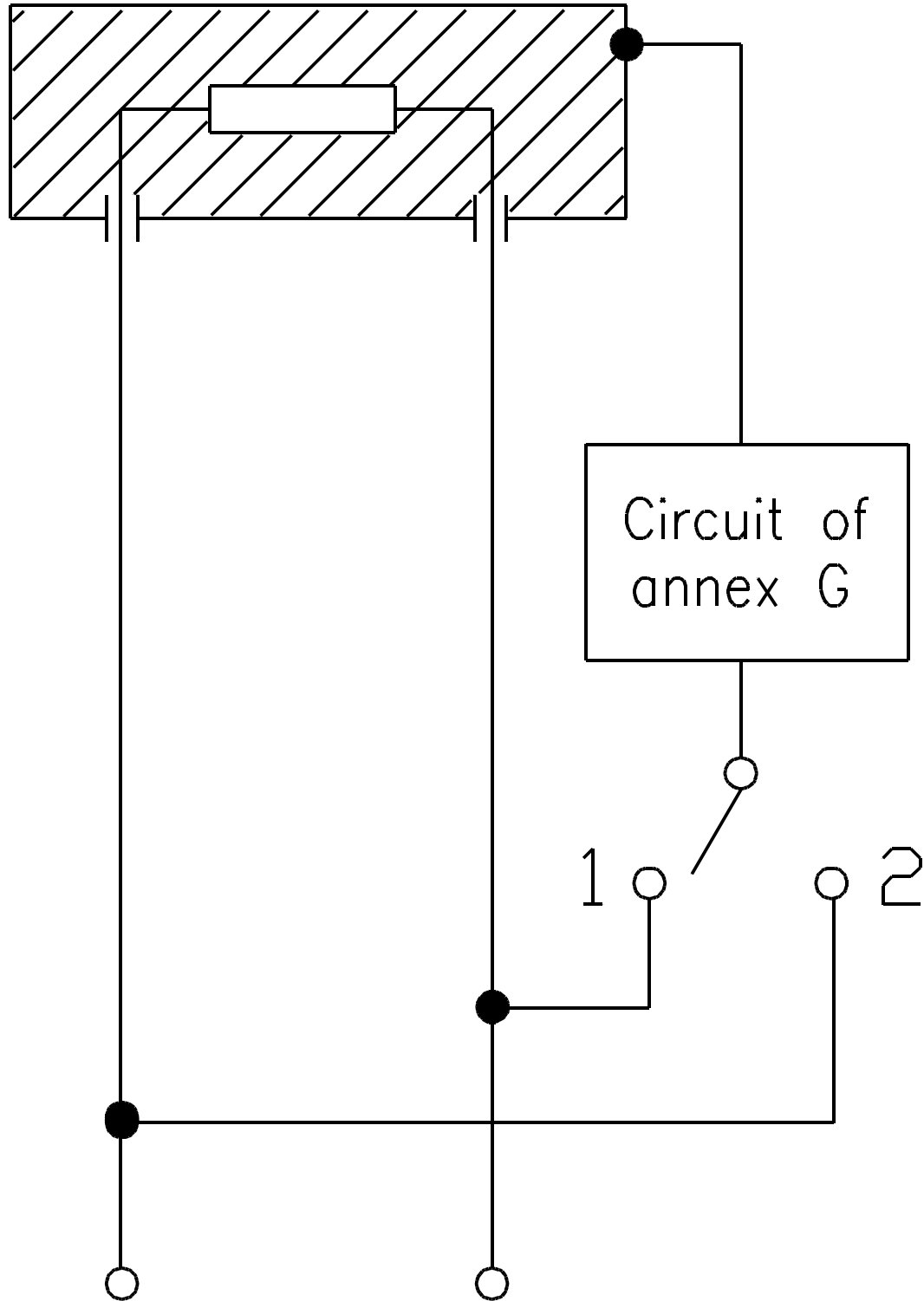

S3749A

Figure 6 – Diagram for leakage current measurement at operating temperature for three-phase connection of CLASS II APPLIANCES

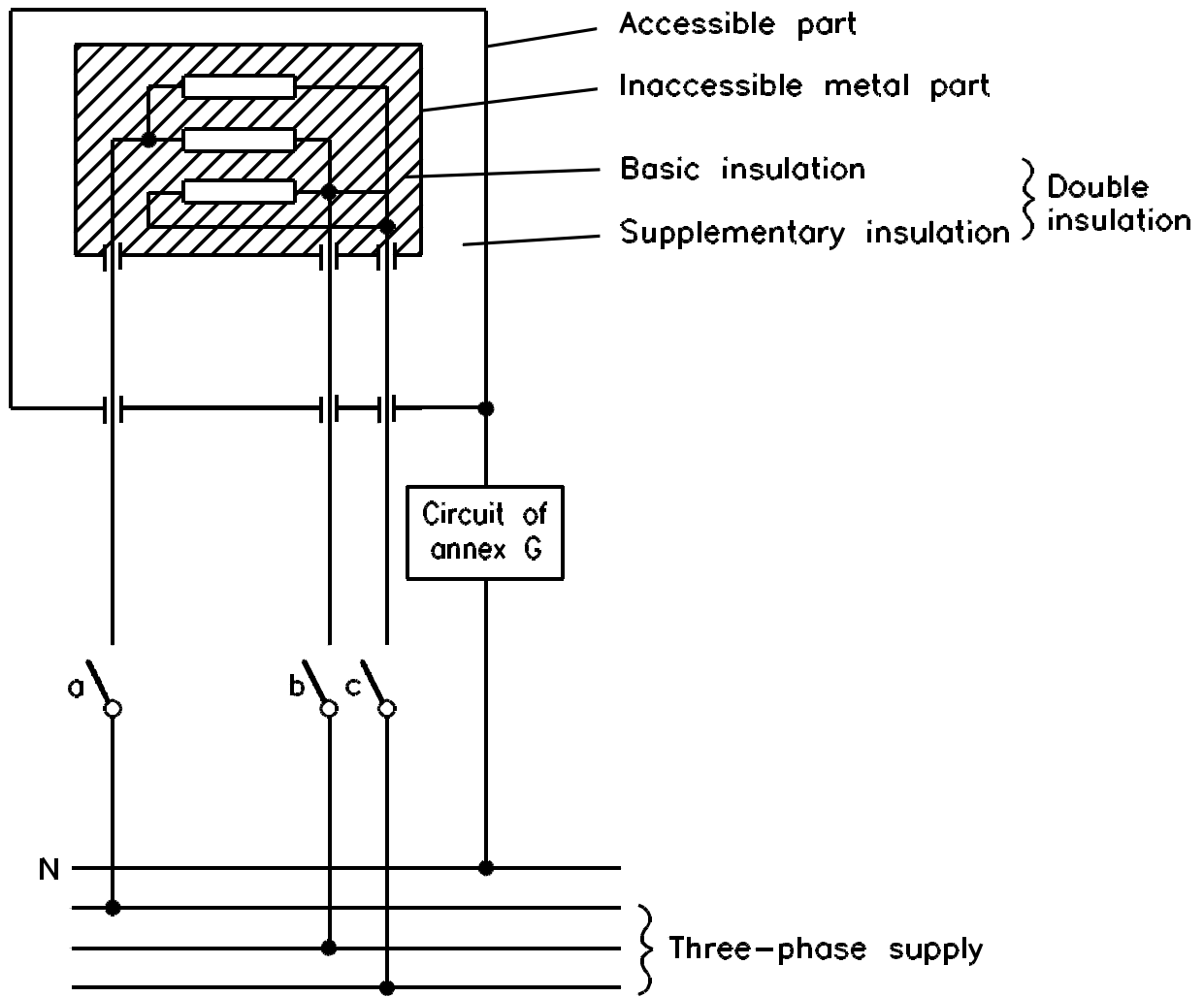

SM479A

Figure 7 – Diagram for leakage current measurement at operating temperature for three-phase connection of appliances other than those of CLASS II

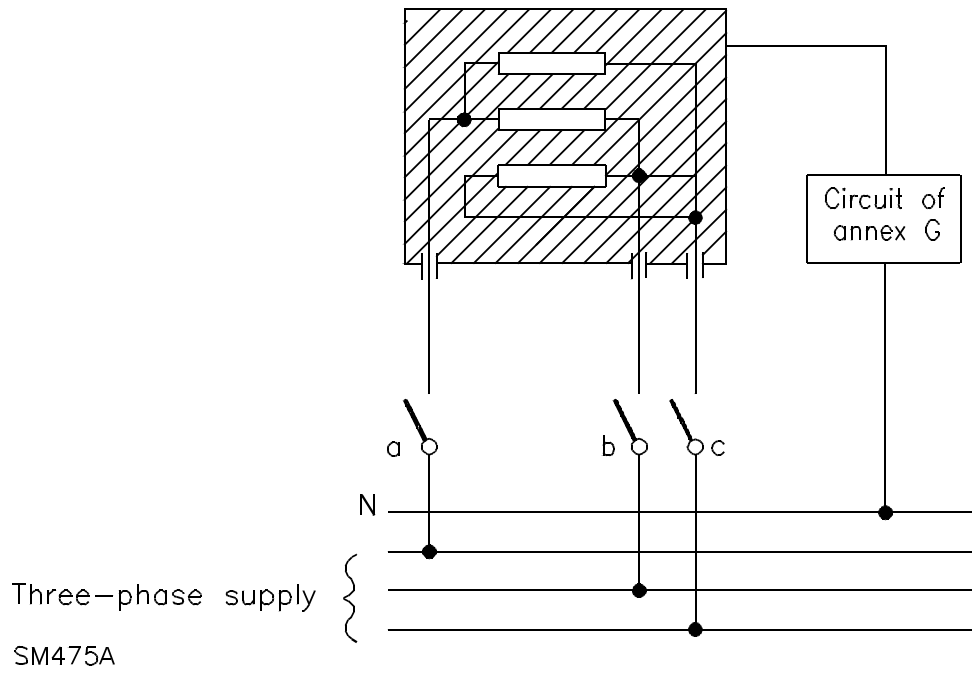

Figure 8 – Diagram for electric strength test at operating temperature

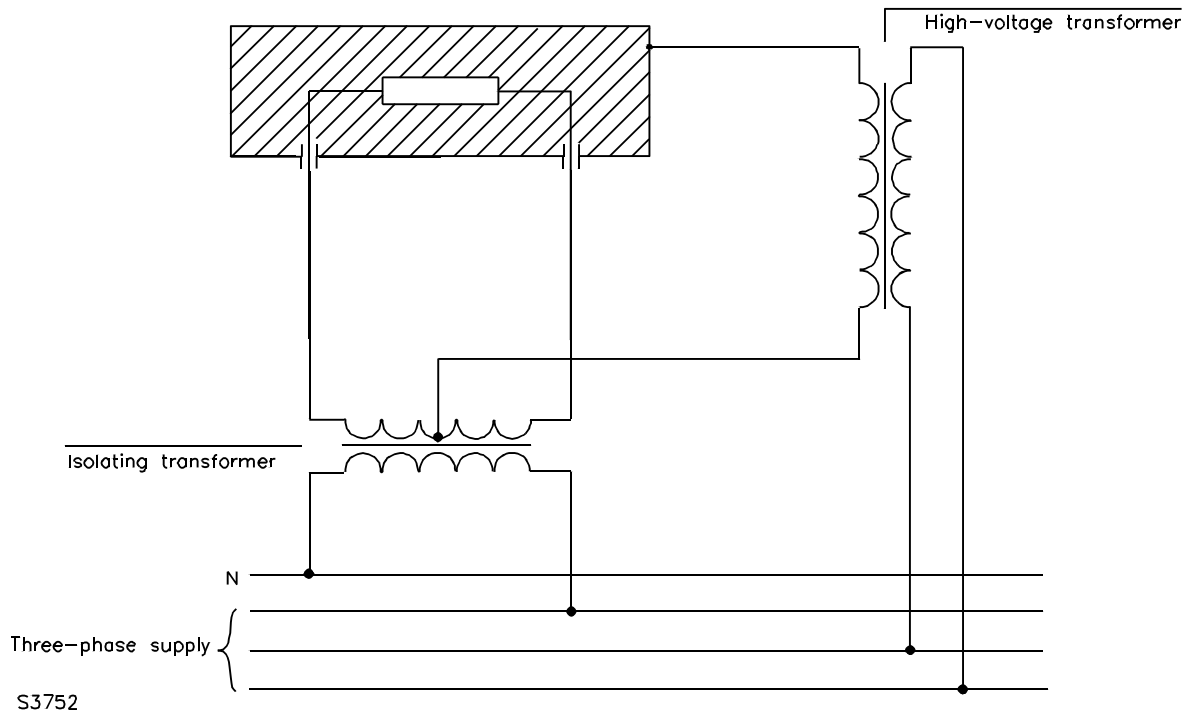
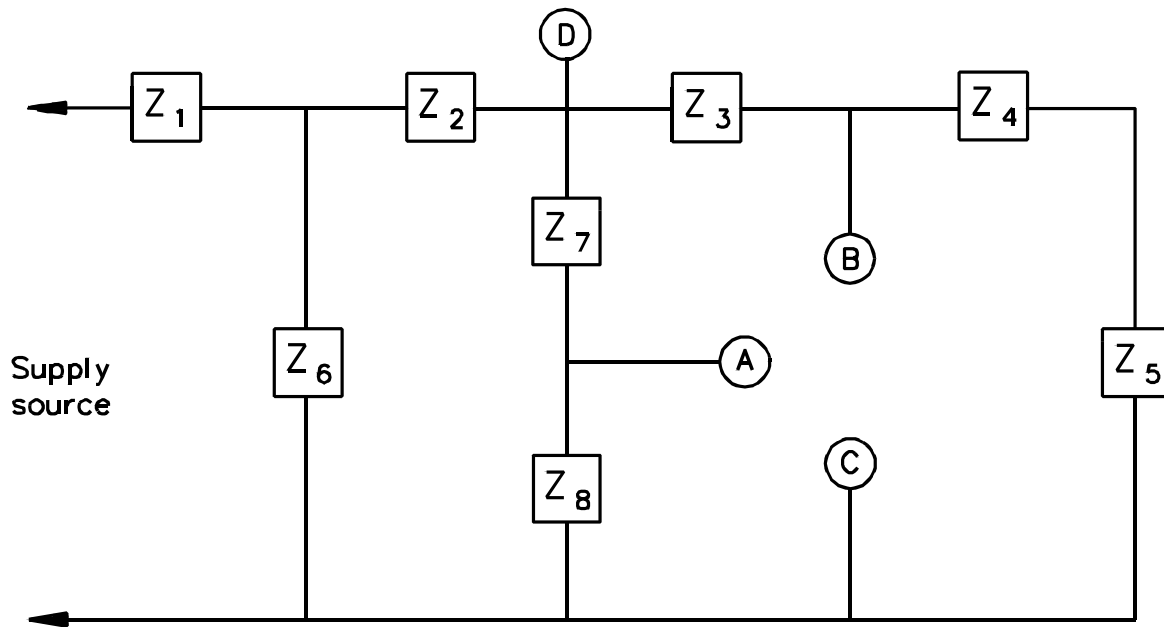

Figure 9 – Example of an ELECTRONIC CIRCUIT with low-power points



SM638

D is a point farthest from the supply source where the maximum power delivered to external load exceeds 15 W.

A and B are points closest to the supply source where the maximum power delivered to external load does not exceed 15 W. These are low-power points.

Points A and B are separately short-circuited to C.

The fault conditions a) to f) specified in 19.11.2 are applied individually to Z_1 , Z_2 , Z_3 , Z_6 , and Z_7 , where applicable.

Figure 10 – Test nail

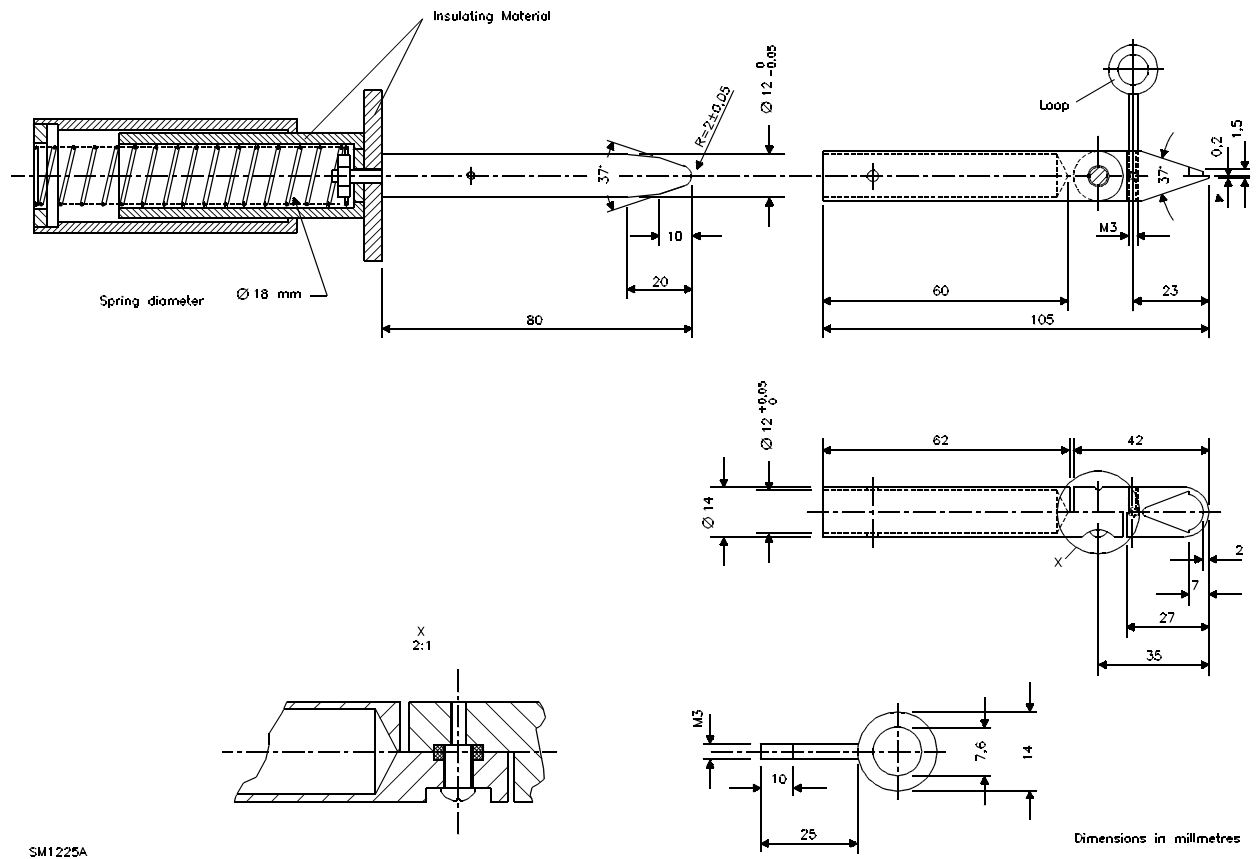

SM1225A

Figure 11 – Flexing test apparatus

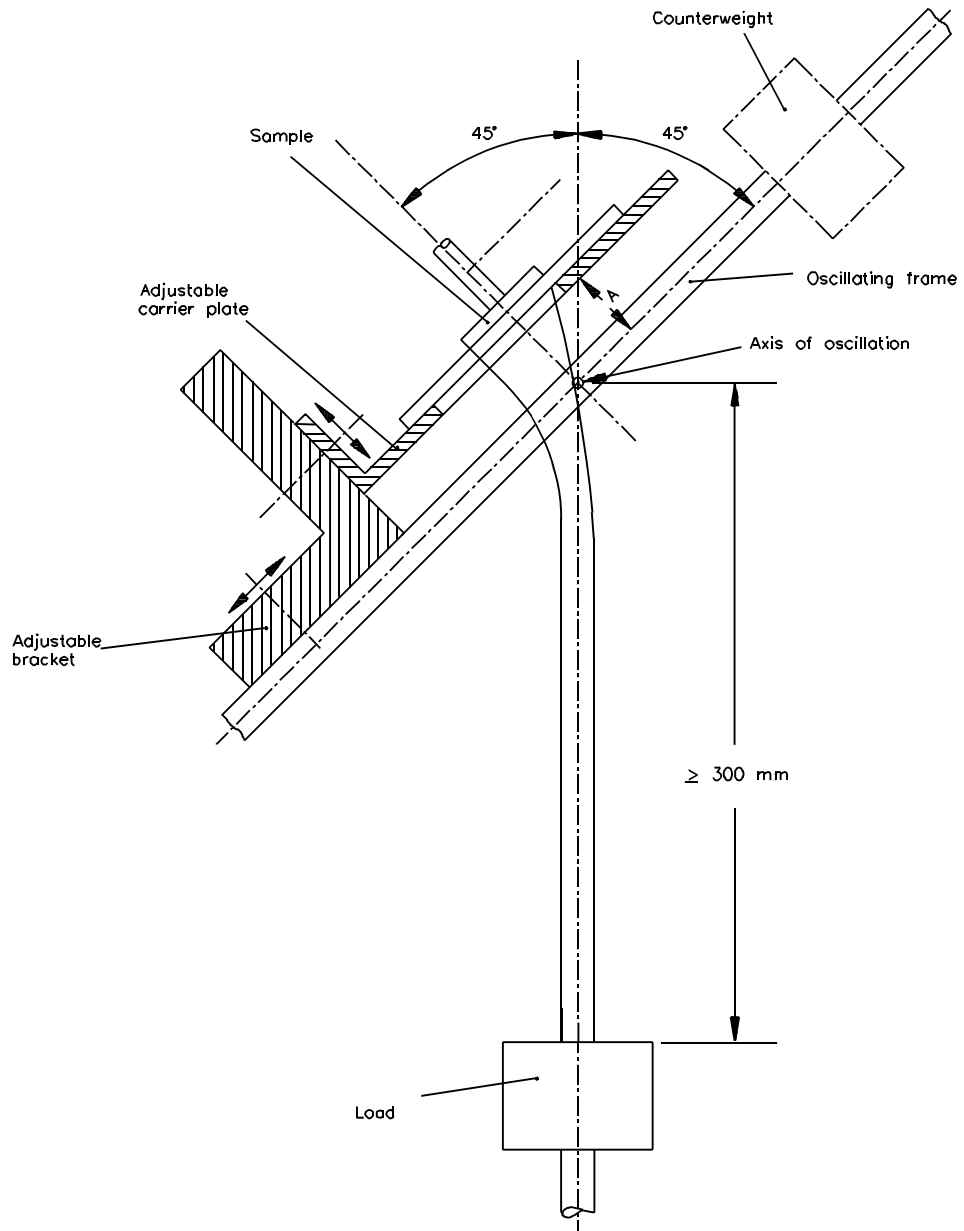

SM1246

Figure 12 – Ball-pressure test apparatus

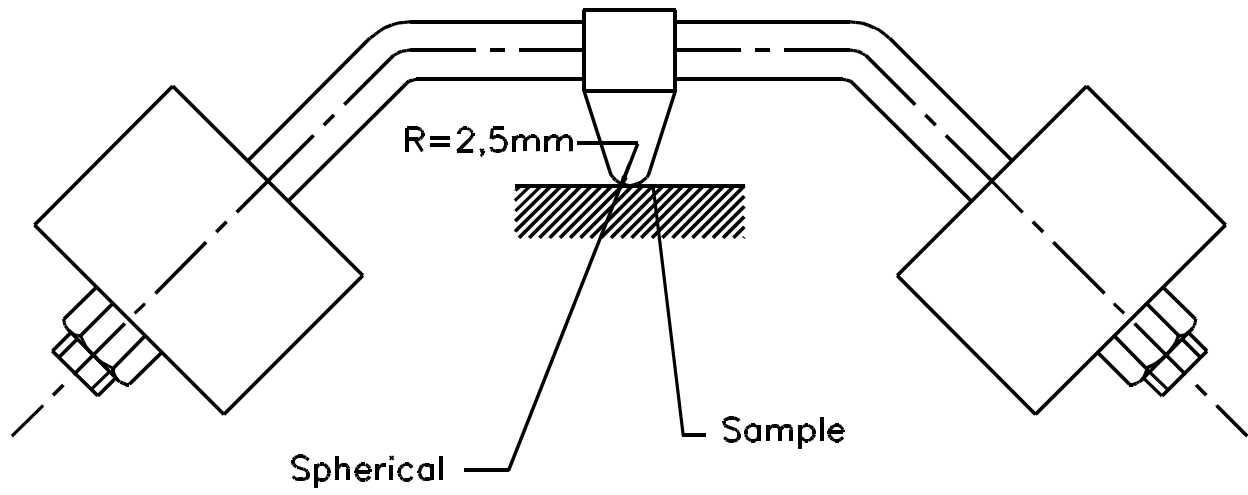

SM504B

Figure 13 - Schematic representation of cord anchorages - ACCEPTABLE CONSTRUCTIONS

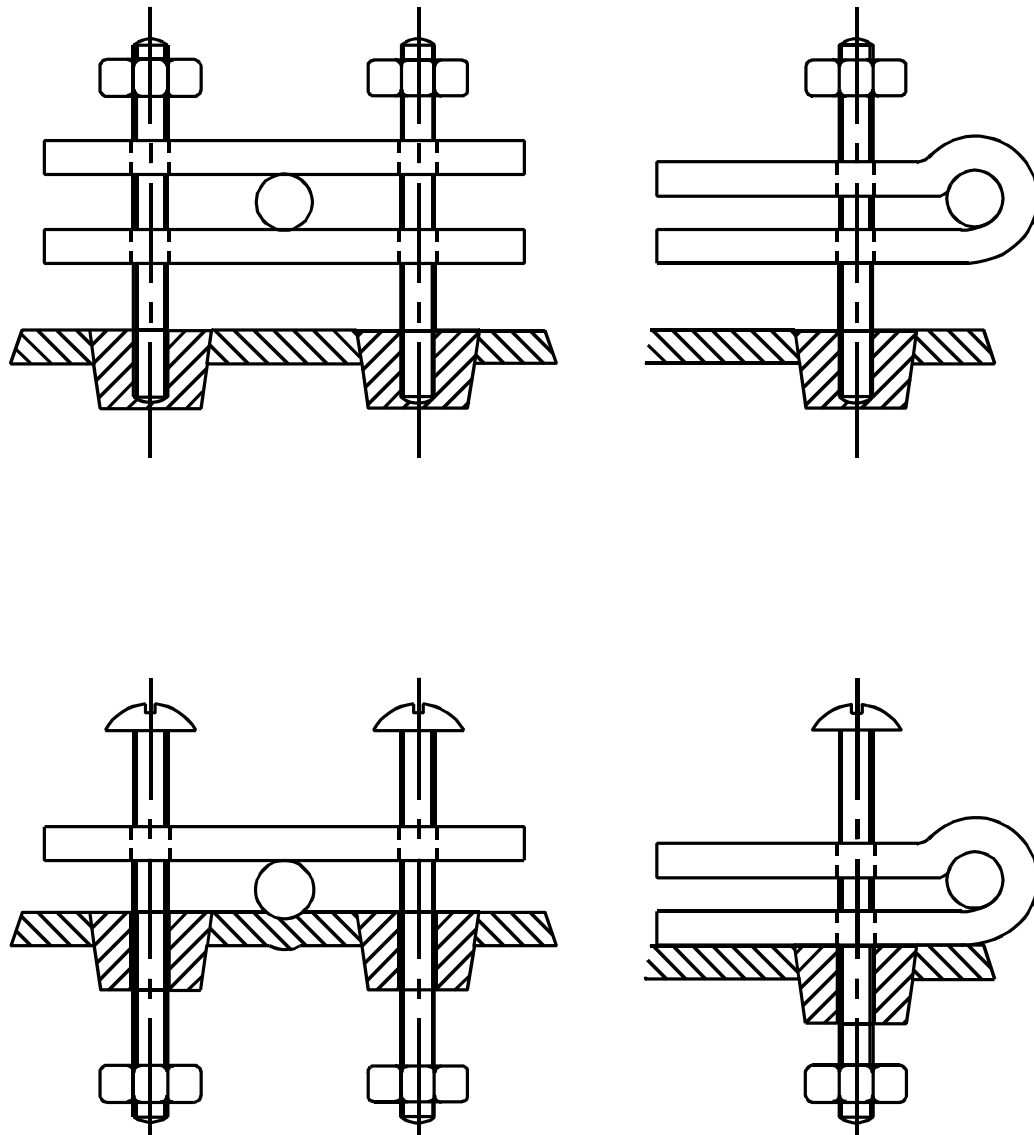

SM1244A

Part of appliance of insulating material and so-shaped that it obviously forms part of a cord clamp.

One of the clamping members is fixed to the appliance.

Clamping screws may pas into threaded holes in the appliance or through CLEARANCE holes, where they are secured by nuts.

Figure 13 – Schematic representation of cord anchorages – ACCEPTABLE CONSTRUCTIONS

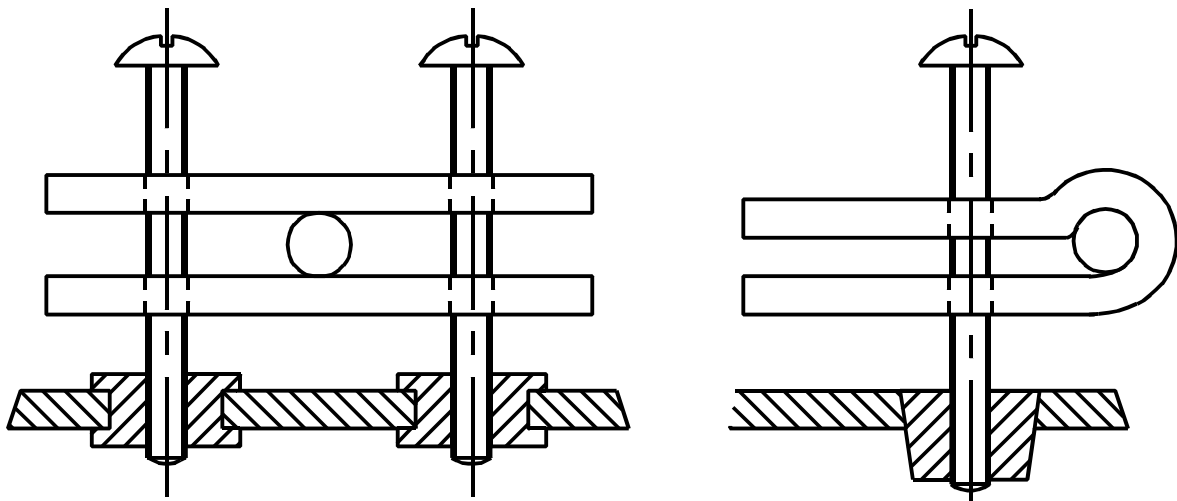

SM1244B

Screws passing through threaded holes in the appliance (or screws passing through CLEARANCE holes in the appliance and secured by nuts) are equally unacceptable.

Figure 14 – Examples of parts of earthing terminals

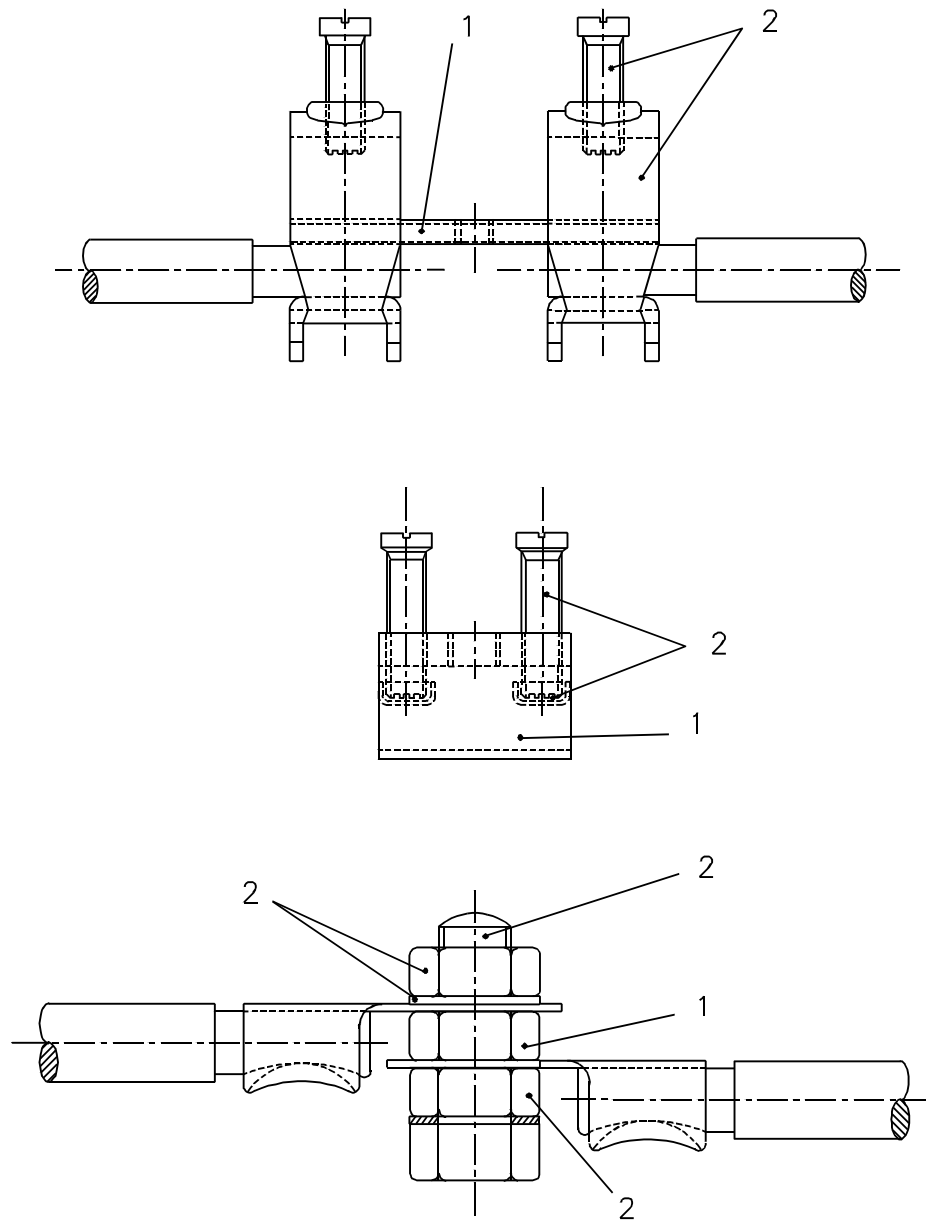

SM1245

- 1. Part providing earthing continuity
- 2. Part providing or transmitting contact pressure

Annex A (normative)

Normative references

A.1 The following normative documents contain provisions which, through reference in this text, constitute provisions of this International Standard. For dated references, subsequent amendments to or revisions of any of these publications do not apply. However, parties to agreements based on this standard are encouraged to investigate the possibility of applying the most recent editions of the normative documents indicated below. For undated references, the latest edition of the normative document referred to applies. Members of IEC and ISO maintain registers of currently valid international Standards.

A.1.1 IEC standards

60051-2: 1984, *Direct acting indicating analogue electrical-measuring instruments and their accessories – Part 2: Special requirements for ammeters and voltmeters.*

60061-1: 1969, *Lamp caps and holders together with gauges for the control of interchangeability and safety – Part 1: Lamp caps.*

60065: 1998, *Safety requirements for mains operated electronic and related apparatus for household and similar general use.*

60068-2-75: 1997, *Environmental testing – Part 2-75: Tests – Test Eh: Hammer tests.*

60085: 1984, *Thermal evaluation and classification of electrical insulation.*

60112: 1979, *Method for determining the comparative and proof tracking indices of solid insulating materials under moist conditions.*

60127 (all parts), *Miniature fuses.*

60227 (all parts), *Polyvinyl chloride insulated cables of rated voltages up to and including 450/750 V.*

60245 (all part), *Rubber insulated cables – Rated voltages up to and including 450\750 V.*

60249-2-4: 1987, *Base materials for printed circuits – Part 2: Specifications – Specification No. 4: Epoxide woven glass fabric copper-clad laminated sheet, general purpose grade.*

60249-2-5: 1987, *Base materials for printed circuits – Part 2: Specification No. 5: Epoxide woven glass fabric copper-clad laminated sheet, of defined flammability (vertical burning test).*

60252: 1993, *A.C. motor capacitors.*

60309 (all parts), *Plugs, socket-outlets and couplers for Industrial purposes.*

60320 (all parts), *Appliance couplers for household and similar general purposes.*

60384-14: 1993, *Fixed capacitors for use in electronic equipment – Part 14: Sectional specification: Fixed capacitors for electromagnetic interference suppression and connection to the supply mains.*

60417: 1973, *Graphical symbols for use on equipment – Index, survey and completion of the single sheets.*

60529: 1989, *Degrees of protection provided by enclosures (IP Code).*

60598-1: 1996, *Luminaries – Part 1: General requirements and tests.*

60695-2-1/0: 1994, *Fire hazard testing – Part 2: Test methods – Section 1/Sheet 0: Glow-wire test – General.*

60695-2-1/1: 1994, *Fire hazard testing – Part 2: Test methods – Section 1/Sheet 1: Glow-wire end product test and guidance.*

60695-2-2: 1991, *Fire hazard testing – Part 2: Test methods – Section 2: Needle-flame test.*

60595-2-3: 1984, *Fire hazard testing – Part 2: Test methods – Bad-connection test with heaters.*

60707: 1981, *Methods of test for the determination of the flammability of solid electrical insulating materials when exposed to an igniting source.*

60730 (all parts) *Automatic electrical controls for household and similar use.*

60906-1: 1986, *IEC system of plugs and socket-outlets for household and similar purposes – Part 1: Plugs and socket-outlets 16 A 250 V a.c.*

60998-2-2: 1991, *Connecting devices for low voltage circuits for household and similar purposes – Part 2-2: Particular requirements for connecting devices as separate entities with screwless-type clamping units.*

60999-1: 1990, *Connecting devices – Safety requirements for screw-type and screwless-type clamping units for electrical copper conductors.*

61058-1: 1996, *Switches for appliances – Part 1: General requirements.*

61558-1: 1997, *Safety of power transformers, power supply units and similar – Part 1: General requirements and tests.*

61558-2-6: 1997, *Safety of power transformers, power supply units and similar – Part 2: Particular requirements for safety isolating transformers for general use.*

A.1.2 ISO standards

1463: 1982, *Metallic and oxide coatings – Measurement of coating thickness – Microscopical method.*

2178: 1982, *Non-magnetic coatings on magnetic substrates – Measurement of coating thickness – Magnetic method.*

7000: 1989, *Graphical symbols for use on equipment – index and synopsis.*

A.2 Reference documents

60083: 1997, *Plugs and socket-outlets for domestic and similar general use standardized in member countries of IEC.*

Annex B

(normative)

Appliances powered by rechargeable batteries

B.1 Scope

This annex applies to appliances powered by rechargeable batteries which are recharged in the appliance.

NOTE – This annex does not apply to battery chargers (IEC 60335-2-29).

All clauses of this standard apply unless otherwise specified in this annex.

B.2 Definitions

B.2.2.9 NORMAL OPERATION: Appliances are operated under the following conditions:

- the appliance supply by its fully charged battery is operated as specified in part 2;
- the appliance is charged, the battery being initially discharged to such an extent that the appliance cannot operate;
- if possible, the appliance is supplied from the supply mains through its battery charger, the battery being initially discharged to such an extent that the appliance cannot operate. The appliance is operated as specified in part 2.

B.2.7.2

NOTE – If a part has to be removed in order to discard the battery before scrapping the appliance, this part is not considered to be detachable even if the instructions state that it is to be removed.

B.4 General conditions for the test

B.4.101 Unless otherwise specified, when appliances are supplied from the supply mains they are tested as specified for MOTOR-OPERATED APPLIANCES.

B.7 Marking and Instructions

B.7.1 The battery compartment of appliances incorporating batteries which are intended to be replaced by the user, shall be marked with the battery voltage and the polarity of the terminals.

NOTES

- 1 If colors are used, the positive terminal shall be identified in red and the negative terminal in black.
- 2 Colour is not to be used as the only indication of polarity.

B.7.12 The instructions shall give information regarding charging.

The instructions for appliances incorporating batteries which are intended to be replaced by the user shall include the following:

- the type reference of the battery;
- the orientation of the battery with regard to polarity;
- the method of replacing batteries;
- details regarding safe disposal of used batteries;
- warning against using non-rechargeable batteries;
- how to deal with leaking batteries.

The instructions for appliances incorporating a battery that contains materials which are hazardous to the environment, shall give details on how to remove the battery and shall state that:

- the battery must be removed from the appliance before it is scrapped;
- the battery is to be disposed of safely;
- the appliance must be disconnected from the supply when removing the battery.

B.7.15 Markings, other than those associated with the battery, shall be placed on the part of the appliance which is connected to the supply mains.

B.8 Protection against access to LIVE PARTS

B.8.2 Appliances having batteries which according to the instructions for use may be replaced by the user, need only have BASIC INSULATION between LIVE PARTS and the inner surface of the battery compartment. If the appliance can be operated without the batteries, DOUBLE INSULATION or REINFORCED INSULATION is required.

B.11 Heating

B.11.7 The battery is charged for the period stated in the instructions for use or 24 h, whichever is longer.

B.19 Abnormal operation

B.19.1 *Appliances are also subjected to the tests of B.19.101, B.19.102, and B.19.103.*

B.19.10 Not applicable.

B.19.101 *Appliances are supplied at RATED VOLTAGE and charged for 168 h.*

B.19.102 *For appliances having batteries which can be removed without the aid of a TOOL, the terminals of which can be short-circuited by a thin straight bar, the terminals of the battery are short-circuited, the battery being fully charged.*

B.19.103 *Appliances having batteries replaceable by the user are supplied at RATED VOLTAGE and operated under NORMAL OPERATION but with the battery removed or in any position allowed by the construction.*

B.21 Mechanical strength

B.21.101 Appliances having pins for insertion into socket-outlets, shall have adequate mechanical strength.

Compliance is checked by subjecting the part of the appliance incorporating the pins to the free fall test, procedure 2 of IEC 60068-2-32.

The number of falls is:

100, if the mass of the part does not exceed 250 g;

50, if the mass of the part exceeds 250 g.

After the test, the requirements of 8.1, 15.1.1, 16.3 and 29.1 shall be met.

B.22 Construction

B.22.3

NOTE – Appliances having pins for insertion into socket-outlets are tested as fully assembled as possible.

B.25 Supply connection and external flexible cords

B.25.13.2

NOTE – The requirements are not applicable to INTERCONNECTION CORDS subjected to SAFETY EXTRA-LOW VOLTAGE.

B.30 Resistance to heat, fire and tracking

B.30.2 For parts of the appliance which are connected to the supply mains during charging period, 30.2.3 applies. For other parts, 30.2.2 applies.

Annex C

(normative)

Ageing test on motors

This test may be carried out when there is doubt with regard to the classification of the insulating system of a motor winding, for example:

- when well-known insulating materials are used in an unconventional way;*
- where combinations of materials of different temperature classes are used at a temperature higher than that allowed for the lowest class used;*
- when materials are used for which sufficient experience is not available, for instance in motors having integral core insulation.*

This test is made on 6 samples of the motor.

The rotor of each motor is locked and a current is passed individually through the rotor winding and stator winding, this current being such that the temperature of the relevant winding is equal to the maximum temperature rise measured during the test of clause 11 increased by 25 K. This temperature is further increased by one of the values chosen from the following table. The corresponding total time during which the current is passed is indicated in the table.

| Temperature increase K | Total time h |
|------------------------|-----------------|
| 0 ± 3 | p ¹⁾ |
| 10 ± 3 | 0,5 p |
| 20 ± 3 | 0,25 p |
| 30 ± 3 | 0,125 p |

¹⁾ p is 8 000 unless otherwise specified in the part 2.

NOTE 1 – The temperature increase chosen is to be agreed by the manufacturer.

The total time is divided into four equal periods, each of them being followed by a period of 48 h during which the motor is subjected to a humidity test as specified in 15.3. After the final humidity test, the insulation shall withstand an electric strength test as specified in 16.3, the test voltage being, however, reduced to 50% of the value specified in item 1 of table 5.

After each of the four periods and before the subsequent humidity test, the leakage current of the insulating system is measured as specified in 13.2, any component not forming part of the insulation system under test being disconnected before the measurement is made.

The leakage current shall not exceed 0,5 mA.

Failure of only one of the six motors during the first of the four periods of the test is ignored.

If one of the six motors fails during the second, third or fourth period of the test, the remaining five motors are subjected to a fifth period followed by the humidity test and the electric strength test.

The remaining five motors shall complete the test.

NOTE 2 – In order to verify that the insulation system is within the temperature class claimed by the manufacturer, the winding temperature for the test is to be equal to the temperature limit for the class of insulation, increased by the temperature increase chosen from the table.

Annex D

(normative)

Alternative requirements for protected motor units

Protected motor units of appliances intended for use unattended shall withstand the following tests.

A motor protector which can be reset by hand shall have a trip-free switching mechanism.

The test of 19.7 is carried out on a separate sample, either in the appliance or with the motor mounted on a bench. The duration of the test is as follows.

- a motor with a SELF-RESETTING PROTECTOR is cycled with a stalled rotor for 72 h for appliances having a short period of electrical stress and for 432 h for appliances having a long period of electrical stress;*
- a motor with a protector which can be reset by hand is operated 60 times with a stalled rotor, the protector being reset as soon as possible after each operation for it to remain closed but in not less than 30 s.*

Temperatures are observed at regular intervals during the first 72 h for motors with SELF-RESETTING PROTECTORS or during the first ten operations for motors with protectors which can be reset by hand. Temperatures shall not exceed the values specified in 19.7.

During the test, the motor protector shall operate reliably and shall comply with the requirements of clause 8. No fire shall occur.

After the period specified for the temperature measurement, the motor shall withstand the electric strength test of 16.3 the test voltage, however, being as specified in 19.13.

Annex E

(normative)

Measurement of CREEPAGE DISTANCES and CLEARANCES

The methods of measuring CREEPAGE DISTANCES and CLEARANCES which are specified in 29.1 are indicated in cases 1 to 10.

These cases do not differentiate between gaps and grooves or between types of insulation.

The following assumptions are made:

- a groove may have parallel, converging or diverging sides;*
- any groove having diverging sides, a minimum width exceeding 0,25 mm, a depth exceeding 1,5 mm and a width at the bottom equal to or greater than 1 mm, is regarded as an air gap, the creepage path following the contour of the groove (case 8);*
- any corner including an angle less than 80° is assumed to be bridged with an insulating link of 1 mm width (0,25 mm for when protection against deposition of dirt is provided) moved into the most unfavourable position (case 3);*
- where the distance over the top of a groove is 1 mm (0,25 mm when protection against deposition of dirt is provided) or more, the CREEPAGE path follows the contour of the groove (case 2);*
- CREEPAGE DISTANCES and CLEARANCES measured between parts moving relative to each other are measured when these parts are placed in their most unfavourable stationary positions;*
- any air gap less than 1 mm wide (0,25 mm when protection against deposition of dirt is provided) is ignored in computing the total CREEPAGE DISTANCE.*

Case 1

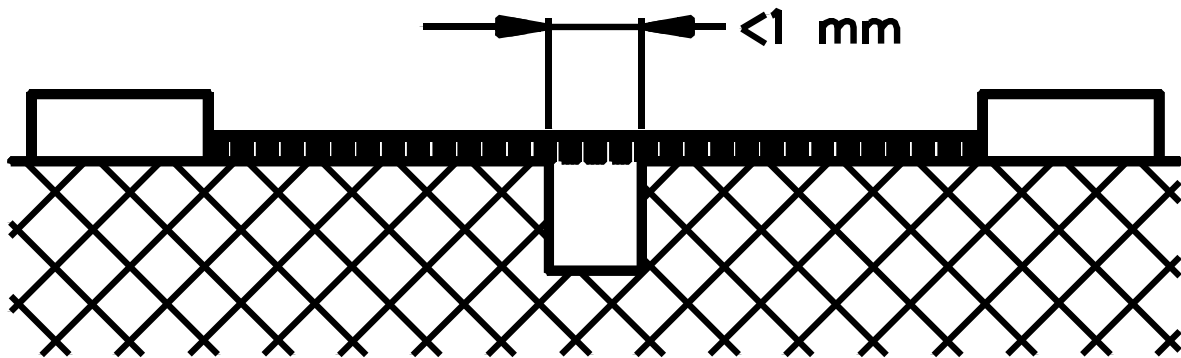
**S3409**

Condition: Path under consideration includes a parallel or converging sided groove of any depth with a width less than 1 mm.

Rule: CREEPAGE DISTANCE and CLEARANCE are measured directly across the groove as shown.

Case 2

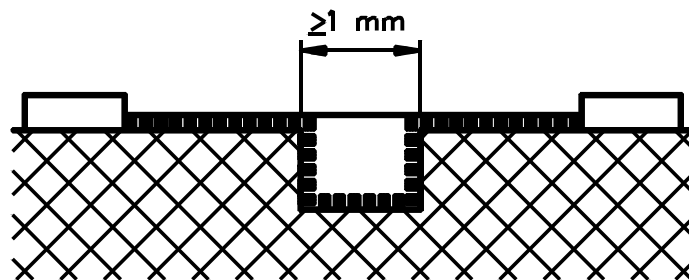
**S3410**

Condition: Path under consideration includes a parallel sided groove of any depth and equal to or more than 1 mm wide.

Rule: CLEARANCE is the "line of sight" distance. Creepage path follows the contour of the groove.

Case 3

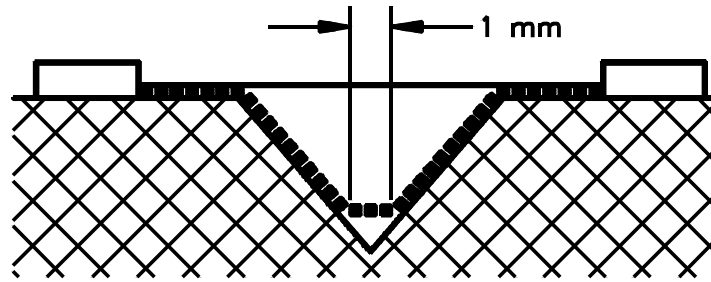

S3411

Condition: Path under consideration includes a V-shaped groove with internal angle of less than 80E and with a width greater than 1 mm.

Rule: CLEARANCE is the "line of sight" distance. Creepage path follows the contour of the groove but "short-circuits" the bottom of the groove by 1 mm link (0,25 mm when protection against deposition of dirt is provided).

_____ CLEARANCE

----- CREEPAGE DISTANCE

Case 4

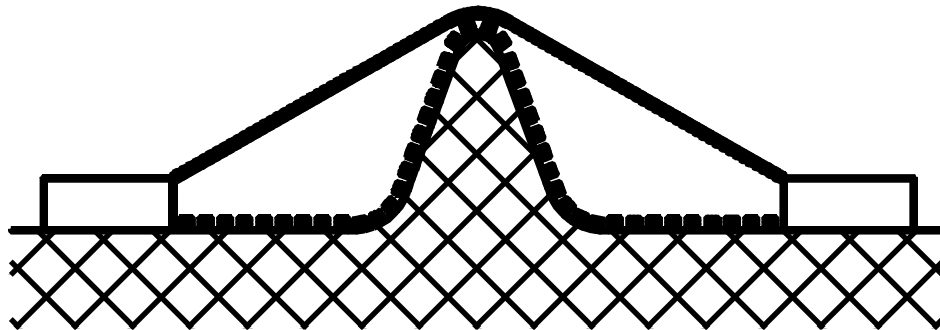

S3412

Condition: Path under consideration includes a rib.

Rule: CLEARANCE is the shortest direct path over the top of the rib. Creepage path follows the contour of the rib.

Case 5

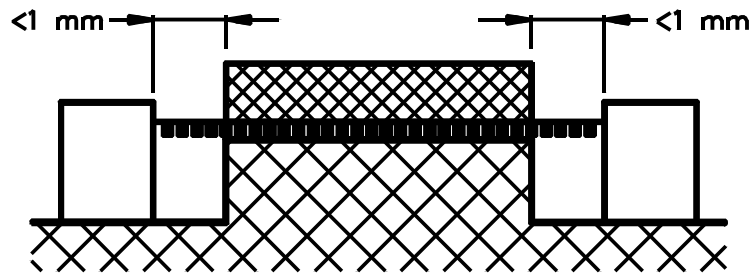

S3413

Condition: Path under consideration includes an uncemented joint with grooves less than 1 mm wide on either side (0,25 mm when protection against deposition of dirt is provided).

Rule: Creepage and CLEARANCE path is the "line of sight" distance shown.

Case 6

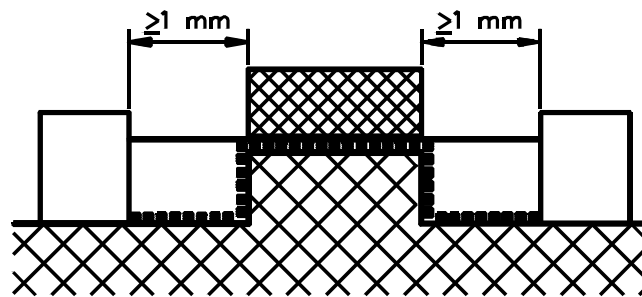

S3414

Condition: Path under consideration includes an uncemented joint with grooves equal to or more than 1 mm wide each side.

Rule: CLEARANCE is the "line of sight" distance. Creepage path follows the contour of the grooves.

_____ CLEARANCE

----- CREEPAGE DISTANCE

Case 7

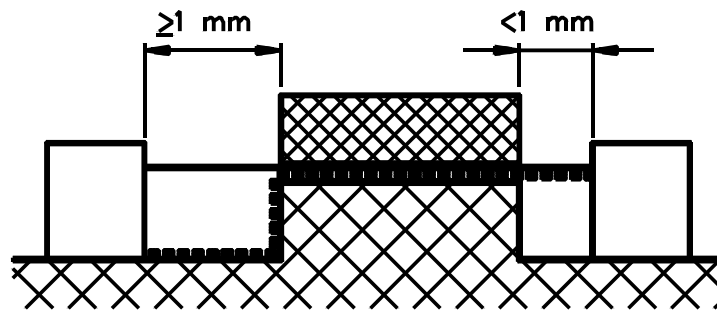

S3415

Condition: Path under consideration includes an uncemented joint with a groove on one side less than 1 mm wide and the groove on the other side equal to or more than 1 mm wide.

Rule: CLEARANCE and creepage path are as shown.

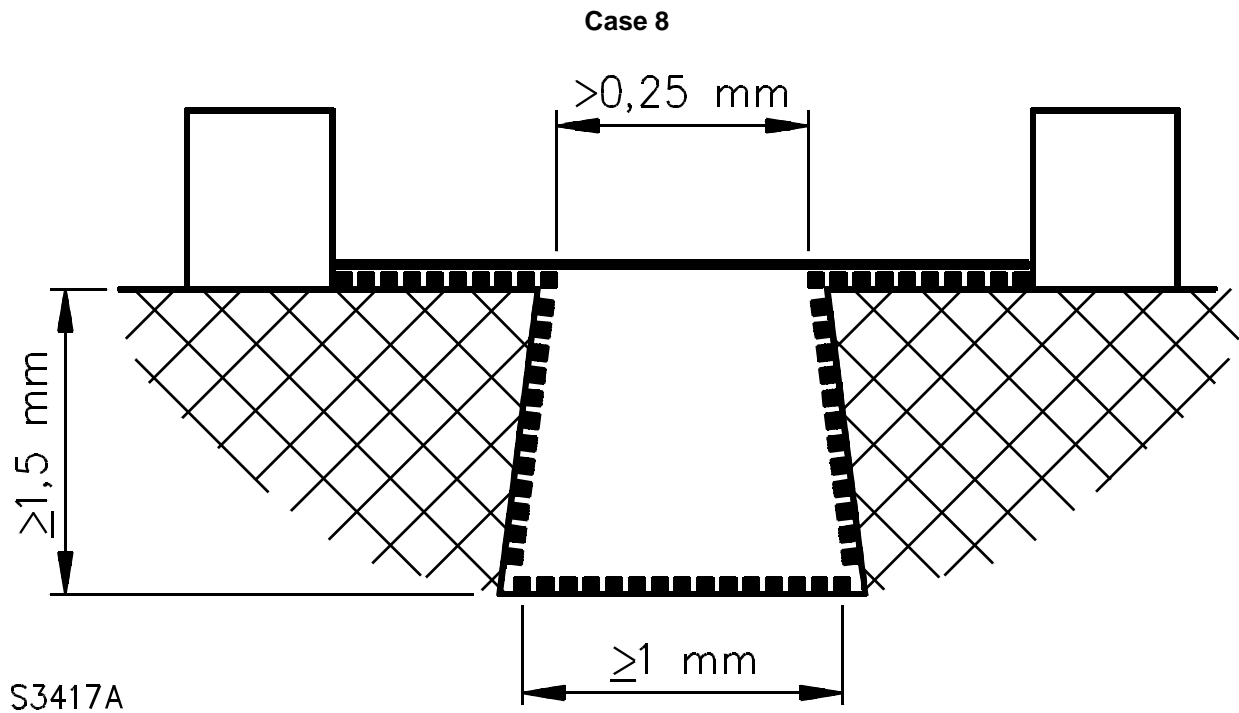

Condition: Path under consideration includes a diverging-sided groove equal to or greater than 1,5 mm deep and greater than 0,25 mm wide at the narrowest part and equal to or greater than 1 mm at the bottom.

Rule: CLEARANCE is the "line of sight" distance. Creepage path follows the contour of the groove.

Case No. 3 also applies to the internal corners if they are less than 80E.

_____ CLEARANCE

----- CREEPAGE DISTANCE

Case 9

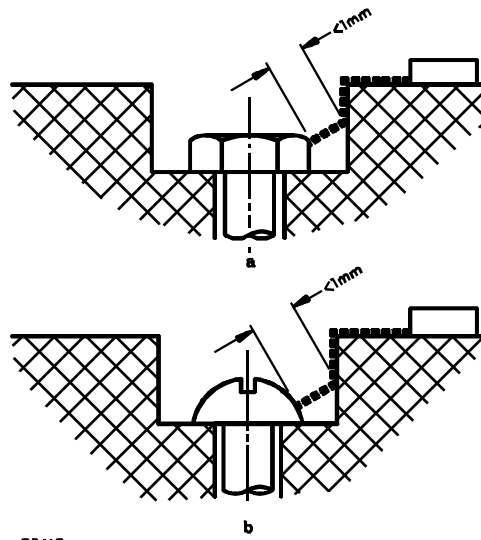

S3418

Gap between head of screw and wall of recess too narrow to be taken into account.

Case 10

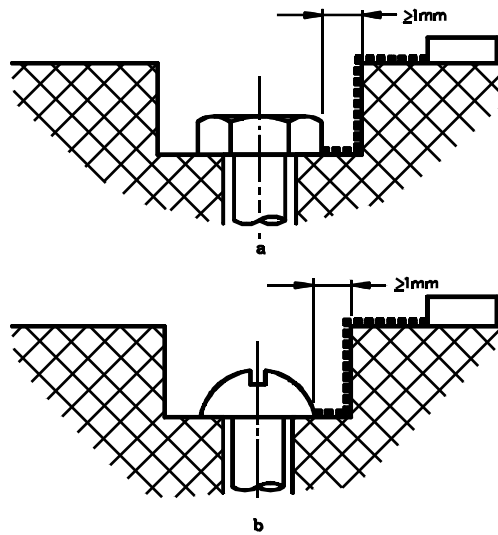

S3419

Gap between head of screw and wall of recess wide enough to be taken into account.

_____ CLEARANCE

----- CREEPAGE DISTANCE

Annex F

(normative)

Motors not isolated from the supply mains and having BASIC INSULATION not designed for the RATED VOLTAGE of the appliance

F.1 Scope

This annex applies to motors having a WORKING VOLTAGE not exceeding 42 V and not isolated from the supply mains and having BASIC INSULATION not designed for the RATED VOLTAGE of the appliance.

All clauses of this standard apply to these motors, unless otherwise specified in this annex.

FDV.1 D1 Modification of F.1:

Replace the wording "42 V" by "30 Vr.m.s. or 42,4 Vpeak or dc".

F.8 Protection against accessibility to LIVE PARTS

F.8.1 NOTE – Metal parts of the motor are considered to be bare LIVE PARTS.

F.11 Heating

F.11.3 The temperature rise of the body of the motor is determined instead of the temperature rise of the windings.

F.11.8 The temperature rise of the body of the motor, where it is in contact with insulating material, shall not exceed the values shown in table 3 for the relevant insulating material.

F.16 Leakage current and electric strength

F.16.3 The insulation between LIVE PARTS of the motor and its other metal parts is not subjected to this test.

F.19 Abnormal operation

F.19.1 The tests of 19.7 to 19.9 are not made.

Appliances are also subjected to the test of F.19.101.

F.19.101 The appliance is operated at RATED VOLTAGE with each of the following defects:

- short circuit of the terminals of the motor, including any capacitor incorporated in the motor circuit;*
- short circuit of each diode of the rectifier;*
- open circuit of the supply to the motor;*
- open circuit of any shunt resistor during operation of the motor.*

Only one defect is simulated at a time, the tests being made consecutively.

NOTE – The defects are simulated as shown in Figure F.1.

F.22 Construction

F.22.101 For CLASS I APPLIANCES incorporating a motor supplied by a rectifier circuit, the d.c. circuit shall be insulated from ACCESSIBLE PARTS of the appliance by DOUBLE INSULATION OR REINFORCED INSULATION.

Compliance is checked by the tests specified for DOUBLE INSULATION AND REINFORCED INSULATION.

F.29 CREEPAGE DISTANCES, CLEARANCES and distances through insulation

F.29.1 **NOTE** – The values specified in table 13 do not apply to distances between LIVE PARTS of the motor and its other metal parts.

Figure F.1 – Simulation of defects

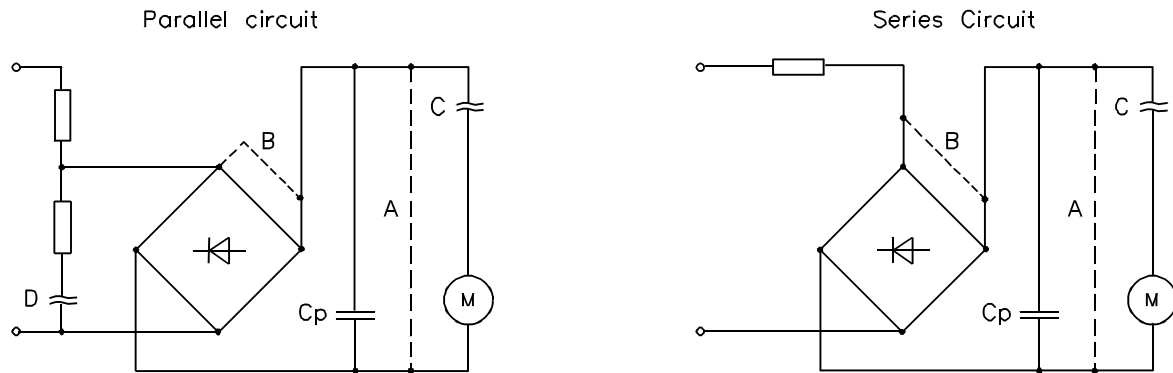

S3753A

_____ original connection

-----short-circuit

. open circuit

A short-circuit of the terminals of the motor

B open circuit of a diode

C open circuit of the supply to the motor

D open circuit of the shunt resistor

Annex G

(normative)

Circuit for measuring leakage currents

Leakage currents are measured using the following circuit.

The leakage current is calculated from the reading of the voltmeter divided by 500 S

NOTE 1 – This network simulates the impedance of the human body and takes into account the physiological reaction as a function of frequency.

NOTE 2 – The voltmeter is to be capable of measuring the true r.m.s. value from zero t 1 MHz.

Figure G.1 – Circuit for measuring leakage currents

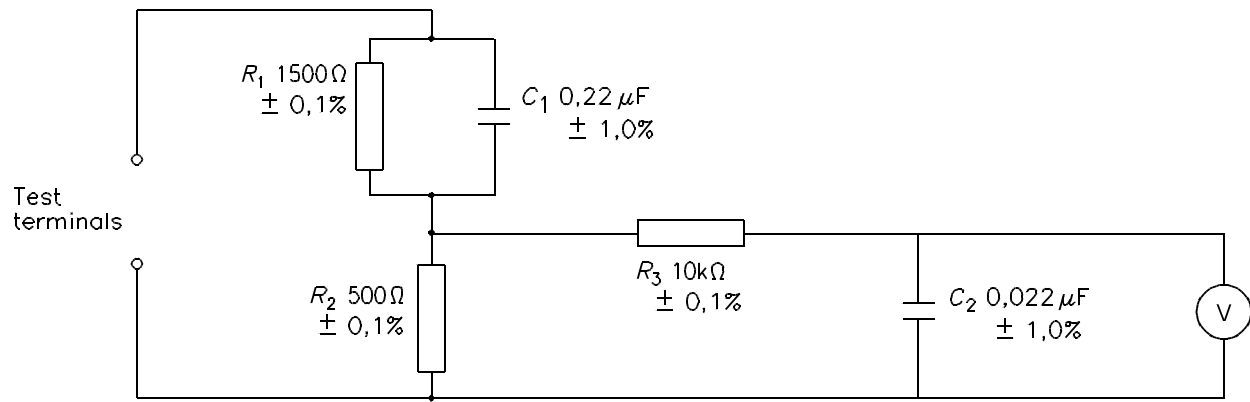

S3991B

Annex H

(informative)

Selection and sequence of the tests of clause 30

Resistance to heat and fire

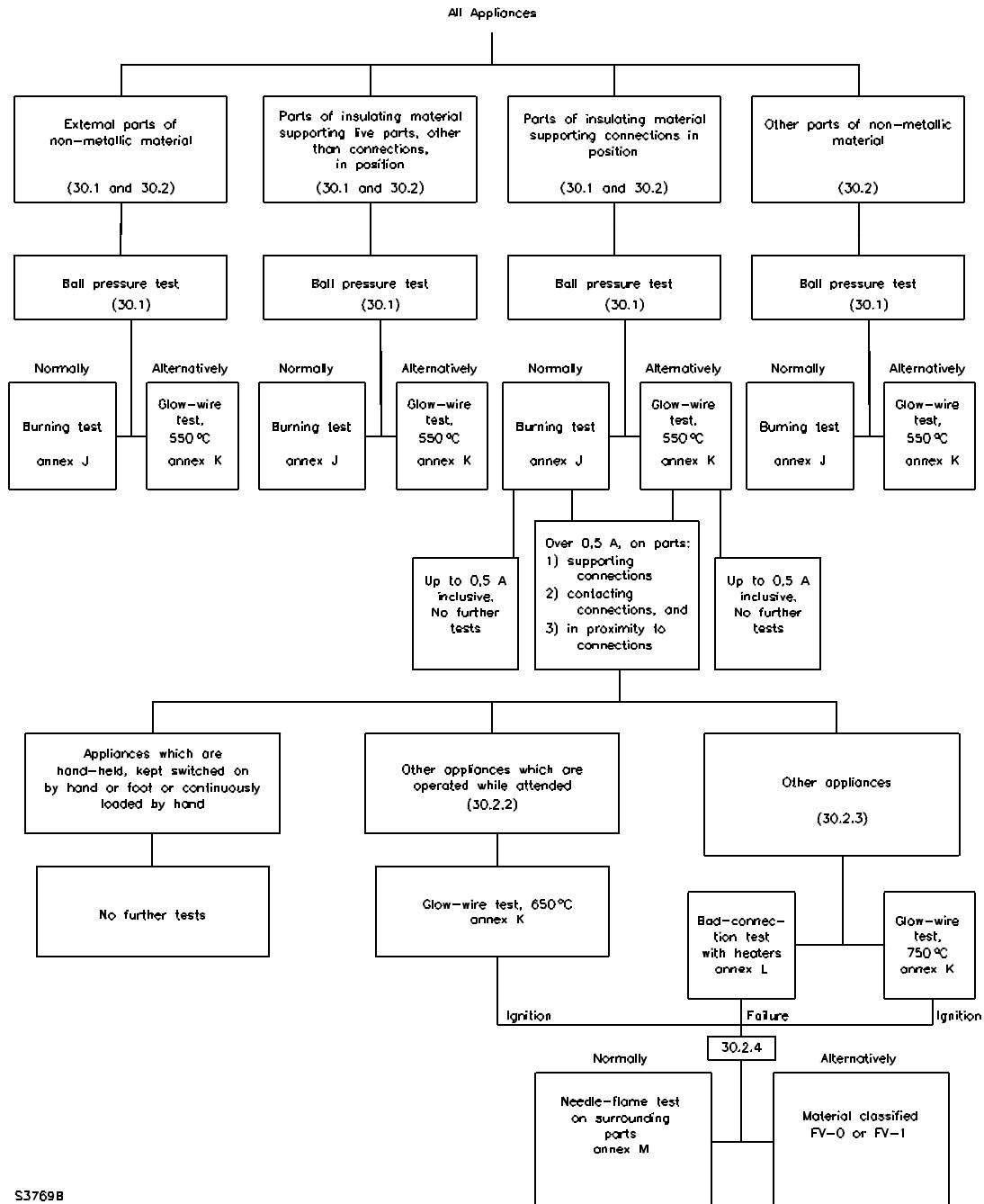

Resistance to tracking

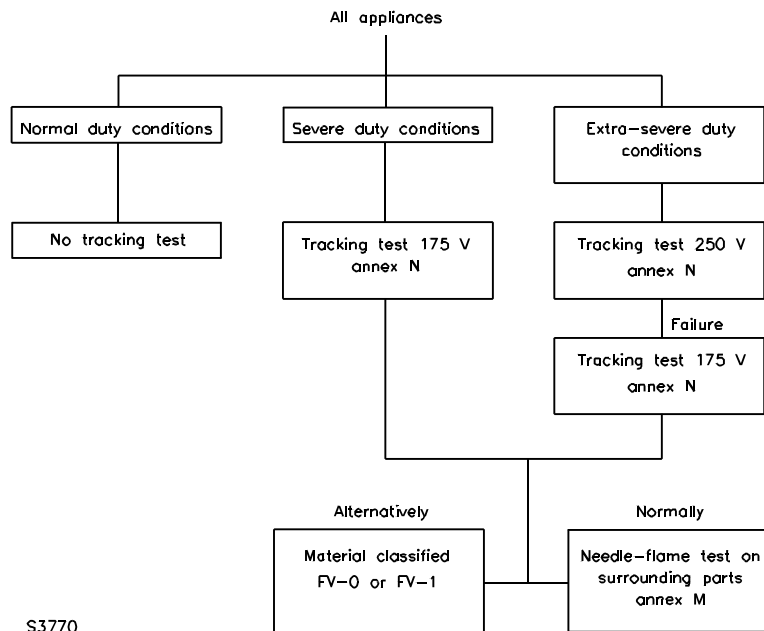
**Annex J**

(normative)

Burning test

The burning test is made in accordance with IEC 60707.

For the purpose of this standard, method FH: Flame-Horizontal specimen, is used.

For the evaluation of the test results, category FH3 applies, the maximum burning rate being 40 mm/min.

If more than one specimen does not withstand the test, the material is rejected.

If one specimen does not withstand the test, the test is repeated on another set of five specimens, all of which shall then withstand the test.

Annex K

(normative)

Glow-wire test

The glow-wire test is made in accordance with IEC 60695-2-1.

For the purpose of this standard, the following applies.

4 Description of test apparatus

The last paragraph before the note is replaced by:

In cases where burning or glowing particles might fall from the specimen onto an external surface underneath the appliance, the test is made with a piece of white pine-wood board, approximately 10 mm thick and covered with a single layer of tissue paper, positioned at a distance of $200\text{ mm} \pm 5\text{ mm}$ below the place where the tip of the glow-wire is applied to the specimen. If the appliance as a whole is tested, it is placed in its normal position of use above the pine-wood board which is covered with a single layer of tissue paper. Before starting the test, the board is conditioned as described in clause 7 for the specimen.

5 Severities

The duration of application of the tip of the glow-wire to the specimen is $30\text{ s} \pm 1\text{ s}$.

10 Observations and measurements

Item c) does not apply.

Annex L

(normative)

Bad-connection test with heaters

The bad-connection test with heaters is made in accordance with IEC 60695-2-3.

For the purpose of this standard, the following applies.

3 General description of the test

Add the following:

Crimped connections are not subjected to the test if

- a bad connection cannot give rise to a fire hazard;
- the continuous current is less than 0,5 A;
- the conductors are chosen in accordance with the following table and are used together with the correct matching connector:

| Continuous current A | Cross-sectional area mm ² | |
|----------------------|--------------------------------------|-----|
| | a | b |
| ≤ 0,5 and # 4,0 | – | 0,5 |
| > 0,5 and # 6,0 | 0,75 | 1,0 |
| > 6,0 and # 10,0 | 1,0 | 1,5 |
| > 10,0 and # 16,0 | 1,5 | 2,5 |
| > 16,0 and # 25,0 | 2,5 | 4,0 |

Column a applies to tinned stranded connectors
 Column b applies to other stranded connectors

Crimped connections are not considered to give rise to a fire hazard if the insulation which retains the connections withstands the glow-wire test of annex K at the test temperatures specified in 30.2.2 or 30.2.3 as applicable.

Sleeves on the ends of stranded conductors intended for insertion into screw terminals are not regarded as crimped connections.

When establishing the value of the continuous current, in-rush currents are disregarded.

4 Description of test apparatus

The last paragraph concerning the evaluation of the possibility of spread of fire including the three dashed paragraphs and the first paragraph of the note are replaced by:

In cases where burning or glowing particles might fall from the specimen onto an external surface underneath the appliance, the test is made with a piece of white pine-wood board, approximately 10 mm thick and covered with a single layer of tissue paper, positioned at a distance of 200 mm \pm 5 mm below the place where the test heater is applied to the specimen. If the appliance as a whole is tested, it is placed in its normal position of use above the pine-wood board which is covered with a single layer of tissue paper. Before starting the test, the board is conditioned as described in clause 6 for the specimen.

5 Severities

The duration of application of the test power is 30 min \pm 1 min.

8 Test procedure

Replace subclause 8.6 by:

The test is made on one specimen. If the specimen does not withstand the test, the test is repeated on two further specimens, both of which shall then withstand the test.

11 Information to be given in the relevant specification

The first dashed paragraph under item h) does not apply.

Annex M

(normative)

Needle-flame test

The needle-flame test is made in accordance with IEC 60695-2-2.

For the purpose of this standard, the following applies.

4 Description of the apparatus

The sixth paragraph is replaced by:

In cases where burning or glowing particles might fall from the specimen onto an external surface underneath the appliance, the test is made with a piece of white pine-wood board, approximately 10 mm thick and covered with a single layer of tissue paper, positioned at a distance of 200 mm \pm 5 mm below the place where the test flame is applied to the specimen. If the appliance as a whole is tested it is placed in its normal position of use above the pine-wood board which is covered with a single layer of tissue paper. Before starting the test, the board is conditioned as described in clause 6 for the specimen.

5 Severities

The duration of application of the test flame is 30 s \pm 1 s.

8 Test procedure

8.4 In the first paragraph the words "or from any source of ignition accidentally applied" do not apply.

Replace the last two paragraphs by:

At the beginning of the test, the test flame is applied in such a way that at least the tip of the flame is in contact with the surface of the specimen.

During the application of the test flame the burner is not to be moved. The test flame is removed immediately after the specified period has elapsed. For examples of test positions, see figure 1.

Replace subclause 8.5 by:

The test is made on one specimen. If the specimen does not withstand the test, the test is repeated on two further specimens, both of which shall then withstand the test.

10 Evaluation of test results

Add:

When a layer of tissue paper is used, there is to be no ignition of the tissue paper or scorching of the white pine-wood board, a slight discoloration of the white pine-wood board being neglected.

Annex N

(normative)

Proof tracking test

The proof tracking test is made in accordance with IEC 60112.

For the purpose of this standard, the following applies.

3 Test specimen

The last sentence of the first paragraph does not apply.

5 Test apparatus

The note in subclause 5.1 does not apply.

Note 4 in subclause 5.3 does not apply and the test solution A described in subclause 5.4 is used.

6 Procedure

The voltage referred to in subclause 6.1 is adjusted to 175 V or 250 V as appropriate.

Subclause 6.2 does not apply and the proof tracking test of subclause 6.3 is made five times. For the latter test, notes 2 and 3 of clause 3 also apply.

Annex P

(normative)

Severity of duty conditions of insulating material with respect to the risk of tracking

The severity of the duty conditions of insulating material with respect to the risk of tracking depends upon the rate of accumulation of any conductive deposit and upon the period of time during which the insulating material is subjected to electrical stress.

For the purpose of the requirement, the following duty conditions are recognized.

1. *Normal duty conditions*: there is virtually no deposition of conductive material and a long period of electrical stress or a light deposition of conductive material and a short period of electrical stress.

The insulating materials used in many household appliances are not considered to be subject to deposition of conductive material.

The insulating materials used in motors which produce carbon dust or in switching devices which are subject to deposition of conductive material but withstand the relevant electric strength test after an appropriate endurance test, are considered to be subject to a light deposition of conductive material.

Insulating materials having a proof tracking index below 175 are considered to be adequate for use under normal duty conditions.

2. *Severe duty conditions*: there is a light deposition of conductive material and a long period of electrical stress or a heavy deposition of conductive material and a short period of electrical stress.

The insulating materials used in HEATING APPLIANCES where air from household premises is caused to blow over these materials, for example in fan heaters, are considered to be subject to a light deposition of conductive material and a long period of electrical stress.

3. *Extra-severe duty conditions*: there is a heavy deposition of conductive material and a long period of electrical stress or an extra-heavy deposition of conductive material and a short period of electrical stress.

Examples of insulating materials used under extra-severe duty conditions are:

- insulating materials used for those parts of a refrigerator which are subject to condensation or to heavy deposition of conductive material, the refrigerator being on circuit continuously for a very long period;
- insulating materials used for those parts of a washing machine or a dishwasher which are subject to pollution by detergents and to a short period of electrical stress.

NOTE – A long period of electrical stress is considered to exist between LIVE PARTS of different potential and between LIVE PARTS and earthed metal parts in the case of:

- appliances intended for continuous operation;
- the input side of the supply switch of appliances not intended for continuous operation;
- appliances provided with a single-pole switch or similar device and connected to the supply by a non-polarized plug.

If there is no single-pole switch, it is assumed that appliances not intended for continuous operation are disconnected in all poles from the supply by means of a switch in the fixed wiring or a plug and therefore a long period of electric stress will not occur.

Annex Q
(normative)

Capacitors

The following clauses and subclauses of IEC 60384-14 apply to capacitors likely to be permanently subjected to the supply mains voltage and used for radio interference suppression or for voltage dividing, with the following modifications.

SECTION ONE – GENERAL

1.5 Terminology

1.5.3 This subclause is applicable

Class X capacitors are tested according to subclass X2.

1.5.4 This subclause is applicable.

1.6 Marking

Items a) and b) of this subclause are applicable.

SECTION THREE – QUALITY ASSESSMENT PROCEDURES

3.4.3.2 Tests

Table II is applicable as follows:

- group 0: subclauses 4.1, 4.2.1 and 4.2.5
- group 1A: subclause 4.1.1
- group 2: subclause 4.12
- group 3: subclause 4.13 and 4.14
- group 6: subclause 4.17
- group 7: subclause 4.18

SECTION FOUR – TEST AND MEASUREMENT PROCEDURES

4.1 Visual examination and check of dimensions

This subclause is applicable

4.2 Electrical tests

4.2.1 This subclause is applicable

4.2.5 This subclause is applicable.

4.2.5.2 Only table 1X is applicable. The values for test A apply, however for capacitors in HEATING APPLIANCES, the values for test B or C apply.

4.12 This subclause is applicable.

NOTE – Only insulation resistance and voltage proof are checked (see table XIII).

4.13 This subclause is applicable.

4.14 This subclause is applicable together with its subclauses 4.14.1, 4.14.3, 4.14.4 and 4.14.7.

4.14.7 *Add:*

NOTE – Only insulation resistance and voltage proof are checked (see table XIV) together with a visual examination to ensure that there is no visible damage.

4.17 This subclause is applicable.

4.18 This subclause is applicable.

Annex R
(normative)

Safety isolating transformers

Safety isolating transformers which are tested with the appliance shall comply with this standard and the following requirements.

R.7 Marking and instructions

R.7.1 Transformers for specific use shall be marked with:

- name, trade mark or identification mark of the manufacturer or responsible vendor;
- model or type reference.

NOTE – The definition of transformers for specific use is given in IEC 61558-1.

R.17 Overload protection of transformers and associated circuits

Fail-safe transformers shall comply with 15.5 of IEC 61558-1.

NOTE – This test is carried out on three transformers.

R.22 Construction

Subclauses 19.1 and 19.1.2 of IEC 61558-2-6 are applicable.

R.29 Creepage distances, clearances and distances through insulation

R.29.1 The distances specified in items 2a, 2b and 3 in table 13 of IEC 61558-1 apply.

NOTE – The values stated for normal pollution are applicable

Annex S

(normative)

Switches

Switches which are tested with the appliance shall comply with this standard and with the following clauses of IEC 61058-1, as modified.

The tests of IEC 61058-1 are carried out under the conditions occurring in the appliance.

Before being tested, switches are operated 20 times without load.

8 Marking and documentation

Switches are not required to be marked, except that incorporated switches shall be marked with the manufacturer's name or trade mark and the type reference.

NOTE – An incorporated switch is a switch which can be tested separately from the appliance.

13 Mechanism

This clause is applicable.

NOTE – The tests may be carried out on a separate sample.

15 Insulation resistance and dielectric strength

15.1 and 15.2 are not applicable.

15.3 is applicable for full disconnection and micro-disconnection.

NOTE – This test is carried out immediately after the humidity test of 15.3 of IEC 60335-1.

17 Endurance

This clause is applicable.

Compliance is checked on three separate appliances or switches.

At the end of the tests, the temperatures rise of the terminals shall not have increased by more than 30 K above the temperature rise measured in clause 11.

NOTE – The text of the second dashed item of 17.3 is not applicable.

20 Clearances, creepage distances and distances through insulation

This clause is applicable for CREEPAGE DISTANCES and CLEARANCES for LIVE PARTS of different potential only, as stated in table 18 for operational insulation and across full disconnection and micro-disconnection.

DVA DE *Add a new annex DVA as follows:*

ANNEX DVA
(informative)
Glossary of Equivalent Terms

Table DVA.1 DE *Addition:*

Table DVA – Glossary of Equivalent Terms

| IEC TERM | EQUIVALENT NORTH AMERICAN TERM |
|----------------------------------|---|
| APPLIANCE INLET | input receptacle |
| AUXILIARY MAINS SOCKET OUTLET | auxiliary supply (output) receptacle |
| CLASS 0 EQUIPMENT | equipment provided with a 2-pin plug and which is not double-insulated equipment |
| CLASS 0I EQUIPMENT | equipment provided with a 2-pin polarized attachment plug and which is not double-insulated equipment but is provided with a grounding terminal |
| CLASS I EQUIPMENT | grounded equipment |
| CLASS II EQUIPMENT | double-insulated equipment |
| CLASS III EQUIPMENT | equipment supplied from SAFETY EXTRA-LOW VOLTAGE (SELV) and in which voltages higher than SELV are not generated |
| CORD ANCHORAGE | strain relief |
| CLEARANCE AND CREEPAGE DISTANCES | through-space and over-surface |
| DETACHABLE POWER SUPPLY CORD | cordset |
| EARTH | ground |
| EARTHED CONDUCTOR (NEUTRAL) | grounded conductor (neutral) |
| EARTHING | grounding |
| FUNCTIONAL EARTH CONDUCTOR | functional ground conductor |
| FUNCTIONAL EARTH TERMINAL | functional ground terminal |
| MAINS | primary supply |
| MAINS PART | primary supply part |
| MAINS PLUG | attachment plug |
| MAINS VOLTAGE | primary supply voltage |
| OPTOCOUPERS | optical isolators |
| OVER-CURRENT RELEASE | overcurrent PROTECTIVE DEVICE |
| PROTECTIVE EARTHING CONDUCTOR | protective grounding conductor |
| PROTECTIVE EARTHING TERMINAL | protective grounding terminal |
| PROTECTIVELY EARTHED | protectively grounded |
| SOCKET OUTLET | output (convenience) receptacle |
| SUPPLY MAINS | source of supply |
| RESIDUAL CURRENT DEVICE (RCD) | ground fault circuit interrupter (GFCI) |
| SHEATH (OF A CABLE) | jacket |

DVB DE *Add a new annex DVB as follows:*

Annex DVB
(Normative)

Terminology

DVB.1 This annex identifies examples of terminology in IEC 60335-1 that are not considered to be suitable in the U.S. and provides the appropriate replacement text. Use of such and similar other terminology elsewhere in IEC 60335-1 is to be similarly replaced.

Table DVB.1.1 DE *Addition:*

Table DVB.1.1 – Terminology

| Subclause reference from this standard | Text in IEC 60335-1 | Appropriate replacement text for UL 60335-1 |
|--|---|---|
| 1 | deals with the safety of | is applicable to |
| 3 | to cause no danger | to reduce the risk of injury to persons |
| 6.1 | protection against | reduction of the risks of injury due to |
| 7.1, | protection against | reduce the risk of |
| 7.12 | used safely | used as intended |
| 7.12.5 | avoid a hazard | reduce the risk of a hazard |
| 8.1, 8.2 | adequate protection against | reduced risk of |
| 8.1.1 | Protection against contact with LIVE PARTS of the lamp cap shall be insured | there is a reduced risk of contact with LIVE PARTS of the lamp cap |
| 19 | will not render the appliance unsafe dangerously malfunction | will not increase the risks of N/A |
| 20.2 | provide adequate protection against The unexpected reclosure of SELF-RESETTING THERMAL CUT-OUTS and overcurrent PROTECTIVE DEVICES shall not cause a hazard. | reduce the risk of Means shall be provided to reduce the risk of a hazard due to the unexpected reclosure of SELF-RESETTING THERMAL CUT-OUTS and overcurrent PROTECTIVE DEVICES. |
| 22.5 | there is no risk of electric shock | the risk of electric shock is reduced |

DVC DC *Add a new annex DVC as follows:*

Annex DVC
(Normative)
UL Component Requirements

DVC.1 All IEC component standard requirements in this standard are replaced by the relevant requirements of UL component standards, examples of which are listed in this annex. This list is not intended to be complete. Products which are determined to comply with clauses 1 to 32 and applicable annexes of this standard and an applicable UL part 2 standard are considered to comply with the UL requirements except that components may require additional evaluation to determine compliance with the applicable UL component standards.

DVC.2 Any undated references to a code or a standard appearing in the requirements of this standard shall be interpreted as referring to the latest edition of that code or standard.

Table DVC.1 DC *Addition:*

Table DVC.1 – UL Component Requirements

| Subclause from this standard | Component type | UL standard |
|------------------------------|--|--|
| 22.2 | Edison-base lampholders | UL 496: Edison-Base Lampholders |
| 23.5 | Wire and Cables | UL 44: Thermostat-Insulated Wires and Cables UL 83: Thermoplastic-Insulated Wires and Cables UL 224: Extruded Insulated tubing UL 510: Polyvinyl Chloride, Polyethylene and Rubber Insulating tape |
| 24 | Surge suppressors | UL 1449: Transient Voltage Surge Suppressors |
| | | UL 224: Extruded Insulated tubing |
| 24 | Printed-wiring boards | UL 796: Printed Wiring Boards |
| 24 | Tubing | UL 224: Extruded Insulating Tubing |
| 24 | Insulating tape | UL 510: Polyvinyl Chloride, Polyethylene, and Rubber Insulating Tape |
| 24 | Switches | UL 20: General-Use Snap Switches UL 98: Enclosed and Dead-Front Switches UL 917: Clock-Operated Switches |
| | | UL 1054: Special-Use Switches |
| | | UL 61058-1: Switches for Appliances |
| | | UL 8730-2-7: Timers and Time Switches |
| 24 | Industrial control equipment | UL 508: Industrial Control Equipment |
| 24 | Circuit breakers | UL 489: Molded-Case Circuit Breakers Molded - Case Switches, and Circuit-Breaker Enclosures |
| 24 | Enclosures for electrical equipment | UL 50: Enclosures for Electrical Equipment |
| 24 | Insulating materials | UL 1446: Systems of Insulating Materials – General |
| 24 | Marking and labeling | UL 969: Marking and Labeling Systems |
| 24 | Fuseholders | UL 512: Fuseholders |
| 24, 25 | Direct plug-in and external power supplies | UL 1310: Class 2 Power Units |
| 24 | Fuses | UL 248-1: Low-Voltage Fuses – Part 1: General Requirements UL 248-2: Low-Voltage Fuses – Part 2: Class C Fuses UL 248-3: Low-Voltage Fuses – Part 3: Class CA and CB Fuses UL 248-4: Low-Voltage Fuses – Part 4: Class CC Fuses UL 248-5: Low-Voltage Fuses – Part 5: Class G Fuses UL 248-6: Low-Voltage Fuses – Part 6: Class H Non-Renewable Fuses |

| Subclause from this standard | Component type | UL standard |
|------------------------------|--------------------------|---|
| | | UL 248-7: Low-Voltage Fuses – Part 7: Class H Renewable Fuses UL 248-8: Low-Voltage Fuses – Part 8: Class J Fuses UL 248-9: Low-Voltage Fuses – Part 9: Class K Fuses UL 248-10: Low-Voltage Fuses – Part 10: Class L Fuses UL 248-11: Low-Voltage Fuses – Part 11: Plug Fuse UL 248-12: Low-Voltage Fuses – Part 12: Class R Fuses UL 248-13: Low-Voltage Fuses – Part 13: Semiconductor Fuses UL 248-14: Low-Voltage Fuses – Part 14: Supplemental Fuses UL 248-15: Low-Voltage Fuses – Part 15: Class T Fuses UL 1417: Special Fuses for Radio- and Television- Type Appliances |
| 24 | Supplementary protectors | UL 1077: Supplementary Protectors for Use in Electrical Equipment |
| 24 | Electric Actuators | UL 8730-2-14: Electric Actuators |
| 24 | Limit controls | UL 353: Limit Controls |
| 24 | Solid-state controls | UL 244A: Solid-State Controls for Appliances |
| 24 | Capacitors | UL 810: Capacitors |
| 24 | DOUBLE INSULATION | UL 1097: DOUBLE INSULATION Systems for Use in Electrical Equipment |

| Subclause from this standard | Component type | UL standard |
|------------------------------|---|--|
| 24 | Attachment plugs, receptacles, and connectors | UL 498: Attachment Plugs and Receptacles |
| 24 | Fuseholders | UL 512: Fuseholders |
| 24 | Printed wiring boards | UL 796: Printed-Wiring Boards |
| 25.7 | Cord sets and POWER SUPPLY CORDS | UL 817: Cord Sets and POWER-SUPPLY CORDS |
| 25.7 | Flexible cords and cable | UL 62: Flexible Cord and Fixture Wire |
| 24 | Quick connect terminals | UL 310: Electrical Quick-Connect Terminals |
| 24, 26 | Wire connectors (including connectors for field wiring) | UL 486A: Wire Connectors and Soldering Lugs for Use with Copper Conductors UL 486B: Wire Connectors for Use With Aluminum Conductors UL 486C: Splicing Wire Connectors UL 486E: Equipment Wiring Terminals for use with Aluminum and/or Copper Conductors |
| 24 | Cathode ray tubes | UL 1418: Cathode-Ray Tubes |
| 24 | Enclosure materials | UL 723: Test for Surface Burning of Building Materials |
| 24 | Thermal cutoffs | UL 1020: Thermal Cutoffs for Use in Electrical Appliances and Components |
| 24 | THERMOSTATS | UL 873: Temperature-Indicating and Regulating Equipment UL 8730-1: Electrical controls for household and similar use, part 1: general requirements UL 8730-2-4: Thermal motor protectors UL 8730-2-9: Temperature Sensing Controls |
| 24 | Communication circuits | UL 497: Protectors for Paired Conductor Communication Circuits UL 497A: Secondary Protectors for Communication Circuits UL 497B: Protectors for Data Communication and Fire Alarm Circuits UL 1863: Communication Circuit Accessories |
| 24 | Lithium batteries | UL 1642: Lithium Batteries |
| 24 | EMI Filters | UL 1283: Electromagnetic Interference Filters |
| 24 | Motor construction | UL 1004: Electric Motors UL 507: Electric Fans |
| 24 | Optical Isolators | UL 1577: Optical isolators |
| 24 | Transformers | UL 1310: Class 2 Power Units; or UL 1585: Class 2 and Class 3 Transformers |
| 24 | High-voltage components | UL 1413: High-Voltage Components for Television-Type Appliances |

| Subclause from this standard | Component type | UL standard |
|------------------------------|---|--|
| 24 | Double-protection capacitors | UL 1414: Across-the-Line, Antenna-Coupling, and Line-by-Pass Capacitors for Radio- and Television-Type Appliances |
| 24 | Fusing resistors | UL 1412: Fusing Resistors and Temperature-Limited Resistors for Radio- and Television-Type Appliances |
| 24 | Outlet boxes | UL 514A: Metallic Outlet Boxes; or UL 514B: Fittings for Cable and Conduit UL 514C: Nonmetallic Outlet Boxes, Flush-Device Boxes, and Covers |
| 24 | Terminal blocks | UL 1059: Terminal Blocks |
| 24 | Adhesives and coatings | UL 746C: Polymeric Materials – Use in Electrical Equipment Evaluations |
| 24 | Polymeric materials | UL 746A: Polymeric Materials – Short Term Property Evaluations; or UL 746B: Polymeric Materials – Long Term Property Evaluations; or UL 746C: Polymeric Materials – Use in Electrical Equipment Evaluations; or UL 746D: Polymeric Materials – Fabricated Parts |
| 24 | Air filter units | UL 900: Air Filter Units |
| 24 | Flammability of Plastic materials 5VA, 5VB, V-0, V-1, V-2, HF-1, HF-2, HB-F, and HB | UL 94: Tests for Flammability of Plastic Materials for Parts in Devices and Appliances |
| 24 | Motor protection | UL 2111: Overheating Protection for Motors |
| 24 | Flammability of liquids | UL 340: Test for Competitive Flammability of Liquids |
| Annex B | Ground-fault circuit interrupters | UL 943: Ground - Fault Circuit Interrupters |

DVD DR *Add a new annex DVD as follows:*

Annex DVD

(Normative)

U.S. REGULATORY REQUIREMENTS FOR USE WITH UL 60335-1 and UL 60335 PART 2 STANDARDS

DVD.1 These requirements provide examples of and references for regulatory requirements that may apply to appliances. Applicability of these requirements is dependent on the construction of the equipment and its intended installation and use. **These requirements are not intended to provide a complete list of all of the applicable requirements;** only to serve as a reference for requirements that most commonly apply to these types of appliances. For complete requirements, the National Electrical Code (NEC), ANSI/NFPA 70-1996; or other referenced document must be consulted.

Table DVD.1.1 DR Addition:

Table DVD.1.1 – U.S Regulatory Requirements for use with UL 60335-1 and UL 60335 Part 2 Standards

| Clause No. of UL 60335-1 | Topic/summary | NEC |
|--------------------------|--|---------------------------------|
| 7.1 7.3 | <p>RATED VOLTAGE marking</p> <p>Based on nominal rating conventions, the following marking schemes shall be used: The voltage rating for equipment with more than one phase supply conductor and an earthed neutral supply conductor shall indicate the phase-to-earth RATED VOLTAGE and the phase-to-phase RATED VOLTAGE, separated by a solidus (/), and shall give an indication of the number of phases of the supply. In order to differentiate this marking from multiple voltage ratings, the number of supply wires, including the neutral, shall also be provided. For example: 120/240 V, 3 wire means the voltage is supplied by two phase wires and one neutral wire with 120 V between each phase conductor and the neutral and 240 V between the phase conductors. 208Y/120 V, 3-phase 4-wire means the voltage is supplied by a three phase power system and one neutral wire with 120 V between each phase conductor and the neutral and 208 V between phases. For cord connected equipment, the RATED VOLTAGE specified shall not exceed the rating of the attachment plug.</p> | 220-2 and ANSI/NEMA C84.1-1995 |
| 7.6, 7.8 | <p>Identification of the protective earthing terminal (terminal for the connection of the equipment grounding conductor or bonding conductor) for permanently connected equipment</p> <p>The terminal for the connection of the equipment earthing conductor (grounding conductor or bonding conductor) shall be identified by (1) a green-colored, not readily removable terminal screw with a hexagonal head; (2) a green-colored, hexagonal, not readily removable terminal nut; or (3) a green-colored pressure wire connector. If the terminal is not visible, the conductor entrance hole shall be marked with the word "green" or otherwise identified by a distinctive green color.</p> <p>The term "Protective Earth" or its abbreviation "PE" are not commonly used in the U.S. Therefore, "G," "GND," "GROUND," or the grounding symbol should be used in conjunction with the above.</p> | 250-119 |
| 7, 25 | <p>Marking for branch circuit overcurrent protection</p> <p>Non-motor operated equipment that is intended to be connected to a dedicated branch circuit shall be marked with the overcurrent PROTECTIVE DEVICE rating if (1) the equipment is rated 13.3 A or less and is not adequately protected by an overcurrent PROTECTIVE DEVICE rated 20 A, or (2) the equipment is rated more than 13.3 A and is not adequately protected by an overcurrent PROTECTIVE DEVICE rated 150 percent of the appliance rating. Where motor overload protection external to the appliance is required, the appliance shall be so marked.</p> | 422-28(e) 422-30 |
| 22.2 | <p>Polarization and polarity of lampholders and extractor post fuseholders</p> <p>If a neutral conductor is provided in equipment that contains an Edison-base screw shell type of a lampholder, the neutral conductor shall be connected to the screw shell of the lampholder. In a similar way the screw shell of an accessible extractor post fuseholder shall be wired to the neutral side of the supply.</p> <p>Cord connected equipment provided with an accessible post extractor fuseholder, a single-pole switch, an output convenience receptacle or an Edison-base lampholder shall be provided with a polarized plug.</p> | 410-42(a), 410-47 410-42 |

| Clause No. of UL 60335-1 | Topic/summary | NEC |
|--------------------------|--|--------------------------|
| 27 | Provisions for protective earthing | Article 100 |
| | The terms "protective earth," "protective earthing" and "earthing" are not commonly used in the U.S. For connections to the grounding system, the following terms should be applied as defined in the NEC. These terms appear in parentheses, where appropriate: | |
| | Ground Grounding Conductor | |
| | Grounded Grounding Conductor, Equipment | |
| 27 | Grounded Conductor Grounding Electrode Conductor | 250-95 Table 250-95 |
| | Grounding System | |
| 9 | Motor control devices | 430-81 |
| | For cord-connected equipment provided with a motor that has a nominal voltage rating greater than 120 V, or that is rated greater than 1/3 hp (locked rotor current over 43 A), and for motor-operated, cord-connected equipment rated more than 12 A, the plug on the power SUPPLY CORD is not sufficient to serve as a disconnect device. A separate motor control device is required. A marking on the appliance shall be provided to indicate the same. Although a motor control device is required, the motor control device need not have a 3 mm contact gap if the equipment is provided with a separate suitable disconnect device (such as the plug on a power SUPPLY CORD). | |
| 24.3 | Orientation of switches and circuit breakers | 240-81 |
| | Vertically mounted disconnect switches and circuit breakers shall be mounted such that the up position of the handle is the "on" position. | |
| 25 | Overcurrent protection for appliances | 422-28 |
| | Contains requirements for sizing branch circuits for appliances. If special overcurrent devices separate from the equipment are required, data or selection of these devices shall be marked on the appliance. | |
| 25 | Branch circuit protection for receptacles | 210-20, 240-10 410-56(h) |
| | Standard supply outlets shall be protected by an overcurrent device in either the equipment or the branch circuit, rated or set at not more than the rating of the receptacle. The overcurrent device shall be of a type that is suitable for branch circuit protection in accordance with the NEC, unless it is supplied by a secondary circuit. Standard supply outlets and receptacles are considered an extension of the branch circuit. Equipment that can plug into these receptacles is evaluated based on the branch-circuit protection normally associated with the type of receptacle. For example, a 15 A, 125 V receptacle is assumed to have branch circuit protection rated 15 A or 20 A. | |
| 25 | Overcurrent protection for distribution transformers | 450-3 |
| 25 | Overcurrent protection for panel boards | 384-16 |
| 25 | Contains additional requirements for equipment provided with panel boards. | |

| Clause No. of UL 60335-1 | Topic/summary | NEC | | | | | | | | | | |
|--|---|------------------|-------------------------------|--------|--|---------------------------|---|--|---|---|---|--|
| 7 | <p>Markings for Class 2 terminals Wiring terminals intended to supply Class 2 outputs in accordance with Article 725 of the National Electrical Code, ANSI/NFPA 70, shall be marked with the voltage rating and "Class 2" or the equivalent. The marking shall be located adjacent to the terminals and shall be visible during wiring.</p> <p>Overcurrent protection for Class 2 limiting Where overcurrent protection is required for Class 2 and Class 3 limiting in accordance with the National Electrical Code, ANSI/NFPA 70, the overcurrent device shall not be interchangeable with devices of higher ratings. A marking is not sufficient regardless of the location of the device.</p> | 725-34 725-35 | | | | | | | | | | |
| 23 | <p>Overcurrent protection of wiring Section 310-15 of the National Electrical Code, ANSI/NFPA 70, gives guidance on the ampacities of conductors.</p> <p>Any overcurrent device is suitable for use with a conductor that meets the following conditions:</p> <ul style="list-style-type: none"> - the length of the conductor does not exceed 3.05 m. - the conductor is located completely within the enclosure of the equipment. - the ampacity of the conductor is not less than the rating of the overcurrent PROTECTIVE DEVICE at the termination of the conductor. <p>An overcurrent device rated not more than 3 times the ampacity of the conductors is suitable if all of the following conditions are met:</p> <ul style="list-style-type: none"> - the length of the conductor does not exceed 7.62 m. - the conductor is located completely within the enclosure of the equipment or is enclosed in a suitable raceway. - the conductor terminates at its load end in one or more overcurrent PROTECTIVE DEVICES. - the ampacity of the conductor is not less than the sum of the ratings of the overcurrent PROTECTIVE DEVICES supplied by the conductor. <p>For solid bus bars, the following meets this requirement:</p> <table border="0" style="width: 100%; border-collapse: collapse;"> <thead> <tr> <th style="text-align: left; border-bottom: 1px solid black;"><u>Material</u></th> <th style="text-align: left; border-bottom: 1px solid black;"><u>Overcurrent protection</u></th> </tr> </thead> <tbody> <tr> <td>Copper</td> <td>Low enough to limit the current density in the bus bar to:</td> </tr> <tr> <td>Electrical-conductor (EC)</td> <td>4.65 A/mm² of bus bar cross section</td> </tr> <tr> <td>grade of aluminum (conductivity is 61 percent of IACS*</td> <td>3.10 A/mm² of bus bar cross section</td> </tr> <tr> <td>Aluminum having a conductivity of 55 percent of IACS*</td> <td>2.75 A/mm² of bus bar cross section</td> </tr> </tbody> </table> <p>* IACS: International Annealed Copper Standard</p> | <u>Material</u> | <u>Overcurrent protection</u> | Copper | Low enough to limit the current density in the bus bar to: | Electrical-conductor (EC) | 4.65 A/mm ² of bus bar cross section | grade of aluminum (conductivity is 61 percent of IACS* | 3.10 A/mm ² of bus bar cross section | Aluminum having a conductivity of 55 percent of IACS* | 2.75 A/mm ² of bus bar cross section | 240-4 240-21(b) 240-21 310-15 |
| <u>Material</u> | <u>Overcurrent protection</u> | | | | | | | | | | | |
| Copper | Low enough to limit the current density in the bus bar to: | | | | | | | | | | | |
| Electrical-conductor (EC) | 4.65 A/mm ² of bus bar cross section | | | | | | | | | | | |
| grade of aluminum (conductivity is 61 percent of IACS* | 3.10 A/mm ² of bus bar cross section | | | | | | | | | | | |
| Aluminum having a conductivity of 55 percent of IACS* | 2.75 A/mm ² of bus bar cross section | | | | | | | | | | | |

| Clause No. of UL 60335-1 | Topic/summary | NEC |
|-----------------------------|---|--|
| 25 | <p>Connection to primary power</p> <p>Methods of connection</p> <p>Flexible cords and plugs are only permitted for portable and stationary equipment and for fixed equipment where the fastening means and mechanical connections are designed to permit ready removal for maintenance and repair.</p> <p>Flexible cords must be provided with an attachment plug for connection to the branch circuit.</p> <p>Attachment plugs shall be rated not less than 125 percent of the RATED CURRENT of the equipment.</p> <p>CLASS II equipment provided with 15- or 20-A standard supply outlets, Edison-base lampholders or a single pole overcurrent or disconnect device or an accessible extractor post fuseholder shall be provided with a polarized type attachment plug.</p> | <p>645-5(a)</p> <p>400-7(a)</p> <p>400-7(b)</p> <p>210-22(c),</p> <p>210-23(a), 210-23(b), 422-4(a),</p> <p>422-23</p> |
| 25 | <p>Permanently connected equipment</p> <p>Connection of wiring systems (i.e. conduit, raceways, etc.)</p> <p>a) Equipment shall have provision for connecting and securing a field wiring system.</p> <p>b) A sheet metal member to which a wiring system is to be connected in the field shall have a thickness not less than 0.85 mm if of uncoated sheet steel; not less than 0.9 mm when of galvanized sheet steel; not less than 1.15 mm when of sheet aluminum; and not less than 1.10 mm when of sheet copper or sheet brass.</p> <p>c) A terminal box or compartment shall be provided in which main supply connections are to be connected and shall be such that all these connections are capable of being readily made and inspected without disturbing the wiring or the appliance after the unit is installed as intended.</p> <p>d) An outlet or terminal box or compartment in which branch circuit connections to a permanently wired appliance are to be made, shall be so located that the power supply connections can be inspected without the necessity of moving the appliance to the extent that it will not be supported by the building structure only.</p> | <p>300-10,</p> <p>300-11,</p> <p>300-12</p> |
| 25 | <p>Sizes of cables and conduits for field wiring connections</p> <p>Trade sizes of different size conduits and the number type and ampacity of cables allowed to be used with different sized conduits are covered in the national codes. Tables 1 and 2 are provided for reference. Table 3 is provided for reference in determining the proper conduit size.</p> | Table 3A |
| 26 | <p>Terminals for field wiring connections</p> <p>Equipment shall be provided with terminals or pig tail leads (not shorter than 150 mm in length and not smaller than no. 18 AWG size) for connection of field installed wiring.</p> | 110-14, 410-24(b) |

| Clause No. of UL 60335-1 | Topic/summary | NEC |
|-----------------------------|--|--|
| 25 | Cord connected equipment The type, minimum length, and other requirements for the power SUPPLY CORD ARE covered in the past 2 standards. | 400-8, 210-52, 400-5, 400-12, 400-3, 400-4, Table 400-5(A) |

Table DVD.1.2 DR Addition:**Table DVD.1.2: Conduit sizes and fill**

| Type | Minimum Size inch | Maximum Size inch | NEC |
|---|-----------------------------|-------------------|--|
| Intermediate metal conduit | 1/2 | 4 | 345-6 |
| | | 4 | 345-7, Chapter 9, Table 1 |
| Electrical metallic tubing (EMT) | 1/2 | 4 | 348-5 |
| | | | 348-6, Chapter 9, Table 1 |
| Flexible metallic tubing | 1/2 (3/8 for special cases) | 3/4 | 349-10 |
| | 1/2 3/8 | | 349-12, Table 350-3 Chapter 9, Table 1 |
| Flexible metal conduit | 1/2 (3/8 for special cases) | | 350-3 |
| | 1/2 3/8 | | 350-3, Table 350-3 Chapter 9, Table 1 |
| Liquid tight flexible metal conduit | 1/2 (3/8 for special cases) | 4 | 351-5 |
| | 1/2 3/8 | | 351-6, Table 350-3 Chapter 9, Table 1 |
| Liquid tight flexible nonmetallic conduit | 1/2(3/8 for special cases) | 4 | 351-24 |
| | 1/2 3/8 | | 351-25, 351-24 Chapter 9, Table 1 Table 350-3 |
| Rigid metal conduit | 1/2 | | 346-5 |
| | | | 346-6, Chapter 9, Table 1 |
| Rigid nonmetallic conduit | 1/2 | | 347-10 |
| | | | 347-11, Chapter 9, Table 1 |

Table DVD.1.3 DR Addition:**Table DVD.1.3: Conduit and knockout sizes**

| Conduit trade size | Internal diameter, inches | Nominal knockout diameter, inches |
|---------------------------|----------------------------------|--|
| 1/2 | 0.622 | 7/8 |
| 3/4 | 0.824 | 1-3/32 |
| 1 | 1.049 | 1-23/64 |
| 1-1/4 | 1.380 | 1-23/32 |
| 1-1/2 | 1.610 | 1-31/32 |
| 2 | 2.067 | 2-15/32 |
| 2-1/2 | 2.469 | 3 |
| 3 | 3.068 | 3-5/8 |
| 3-1/2 | 3.548 | 4-1/8 |
| 4 | 4.026 | 4-5/8 |
| 4-1/2 | 4.506 | 5-1/8 |
| 5 | 5.047 | 5-5/8 |
| 6 | 6.065 | 6-3/4 |

Table DVD.1.4 DR Addition:

Table DVD.1.4: Maximum number of conductors in trade sizes of conduit or tubing

| Conduit or tubing trade size (inches) | | 1/2 | 3/4 | 1 | 1 1/4 | 1-1/2 | 2 | 2-1/2 | 3 | 3-1/2 | 4 | 5 | 6 |
|--|--------------------------|-----|-----|-----|-------|-------|----|-------|-----|-------|-----|-----|-----|
| Type letters | Conductor size AWG/kcmil | | | | | | | | | | | | |
| TW, XHHW (14 through 18) RH (14 + 12) | 14 | 9 | 15 | 25 | 44 | 60 | 99 | 142 | | | | | |
| | 12 | 7 | 12 | 19 | 35 | 47 | 78 | 111 | 171 | | | | |
| | 10 | 5 | 9 | 15 | 26 | 36 | 60 | 85 | 131 | 176 | | | |
| | 8 | 2 | 4 | 7 | 12 | 17 | 28 | 40 | 62 | 84 | 108 | | |
| RHW and RHH (without outer covering), RH (10 + 8) THW, THHW | 14 | 6 | 10 | 16 | 29 | 40 | 65 | 93 | 143 | 192 | | | |
| | 12 | 4 | 8 | 13 | 24 | 32 | 53 | 76 | 117 | 157 | | | |
| | 10 | 4 | 6 | 11 | 19 | 26 | 43 | 61 | 95 | 127 | 163 | | |
| | 8 | 1 | 3 | 5 | 10 | 13 | 22 | 32 | 49 | 66 | 85 | 133 | |
| TW, THW, FEPB (6 through 2), RHW and RHH (without outer covering) RH, THHW | 6 | 1 | 2 | 4 | 7 | 10 | 16 | 23 | 36 | 48 | 62 | 97 | 141 |
| | 4 | 1 | 1 | 3 | 5 | 7 | 12 | 17 | 27 | 36 | 47 | 73 | 106 |
| | 3 | 1 | 1 | 2 | 4 | 6 | 10 | 15 | 23 | 31 | 40 | 63 | 91 |
| | 2 | 1 | 1 | 2 | 4 | 5 | 9 | 13 | 20 | 27 | 34 | 54 | 78 |
| | 1 | | 1 | 1 | 3 | 4 | 6 | 9 | 14 | 19 | 25 | 39 | 57 |
| | 1/0 | | 1 | 1 | 2 | 3 | 5 | 8 | 12 | 16 | 21 | 33 | 49 |
| | 2/0 | | 1 | 1 | 1 | 3 | 5 | 7 | 10 | 14 | 18 | 29 | 41 |
| | 3/0 | | 1 | 1 | 1 | 2 | 4 | 6 | 9 | 12 | 15 | 24 | 35 |
| | 4/0 | | | 1 | 1 | 1 | 3 | 5 | 7 | 10 | 13 | 20 | 29 |
| | 250 | | | 1 | 1 | 1 | 2 | 4 | 6 | 8 | 10 | 16 | 23 |
| | 300 | | | 1 | 1 | 1 | 2 | 3 | 5 | 7 | 9 | 14 | 18 |
| | 350 | | | 350 | 1 | 1 | 1 | 3 | 4 | 6 | 8 | 12 | 16 |
| | 400 | | | 400 | 1 | 1 | 1 | 2 | 4 | 5 | 7 | 11 | 14 |
| | 500 | | | 500 | 1 | 1 | 1 | 1 | 3 | 4 | 6 | 9 | |
| | 600 | | | | | 1 | 1 | 1 | 2 | 4 | 5 | 7 | 11 |
| | 700 | | | | | | 1 | 1 | 1 | 2 | 3 | 4 | 7 |
| 750 | | | | | | 1 | 1 | 1 | | 3 | 4 | 6 | 9 |

NOTE 1 – This table is for concentric stranded conductors only. For cables with compact conductors, the dimensions in Chapter 9, Table 5A of the National Electrical Code, ANSI/NFPA 70, shall be used.

NOTE 2 – Conduit fill for conductors with a -2 suffix is the same as for those types without the suffix.

| Clause No. of UL 60335-1 | Topic/summary | NEC |
|-----------------------------|--|--------------------|
| 25, 26 | <p>Temperature markings for field wiring compartments</p> <p>If the wires in a terminal box or compartment intended for power supply connection of equipment can attain a temperature higher than 60EC during NORMAL OPERATION, the unit shall be marked near the point at which the supply connections are made with the minimum temperature rating of the conductors that must be used.</p> | 110-14(c), 310-10 |
| 25, 26 | <p>Conductor material markings for field wiring terminals</p> <p>Supply wiring terminals in equipment shall be marked to indicate the material of the conductor appropriate for the terminal used. This marking shall be independent of all other markings on terminal connectors and shall be visible during and after installation of the wiring.</p> | 110-14 |
| 7.8, 26 | <p>Identification of terminals for connection of an earthed (grounded) conductor (neutral)</p> <p>a) Terminals and leads for the connection of the earthed (grounded) circuit conductor (neutral) are required to be identified by a distinctive white marking or other equally effective means.</p> <p>b) A field-wire connected appliance rated 125 or 125/250 V (3-wire + ground) or less shall have one terminal or lead identified for the connection of the grounded conductor of the supply circuit.</p> <p>c) A field wiring terminal or lead for the connection of an appliance protective ground conductor shall be provided and shall be of the proper size. The surface color of the lead shall be green with or without yellow stripes. No other leads shall be of the same color. A screw type pressure wire connector intended for connection of appliance ground conductor shall be identified by the marking "G," "GR," "GND," "Ground," or the symbol  (IEC 417, No. 5019).</p> <p>d) The wire binding screw or pressure wire connector shall be so located that it is unlikely to be removed during the servicing of the appliance not involving the disconnection of supply conductors.</p> | 200-9 200-10(e) |
| 25, 26 | <p>Wire-binding screws</p> <p>a) A wire-binding screw may be employed at a wiring terminal intended for connection of a No. 10 AWG (5.3 mm²) or smaller conductor wire. Upturned lugs, a cupped washer or the equivalent shall be provided to hold the wire in position. A No. 6 or M4 for No. 14 AWG, No. 8 or M 4.5 for 12 AWG and a No. 10 or M5 screw for 10 AWG wire.</p> <p>b) A No. 14 AWG (2.1 mm²) is the smallest conductor that is capable of being used for branch circuit wiring and is anticipated at a terminal for connection of a branch circuit conductor.</p> <p>c) A terminal plate for a wire-binding screw shall be of metal and not smaller than 1.5 mm in thickness and shall have two complete threads in the metal. Local extrusion of the metal to provide two full threads is permitted.</p> | 110-14(a) |

| Clause No. of UL 60335-1 | Topic/summary | NEC |
|--------------------------|---|---|
| 26 | <p>Range of conductor sizes to be accepted by field wiring terminals</p> <p>Terminals must be suitable for the wire gauges commonly used in the U.S. It is required that current-carrying conductors be rated 125 percent of the equipment rating. Therefore, once the equipment rating exceeds 80 percent of the capacity of the wiring in the branch circuit, the next high capacity wire gauge must be used. Refer to the appropriate article in the National Electrical Code, ANSI/NFPA 70, for ampacity tables.</p> <p>The range of conductor sizes for earthing conductors (equipment grounding or bonding conductors) is specified elsewhere.</p> | <p>Article 310, ampacity tables</p> <p>Table 250-95</p> |
| 25, 26 | <p>Terminals and leads for field wiring</p> <p>a) Field wiring connections shall be made through the use of suitable solder lugs, pressure connectors (including set-screw type) firmly bolted or held by a screw or splices to flexible leads.</p> <p>b) If leads are provided, they shall be at least 150 mm unless it is evident that the use of a longer lead might result in a risk of fire or shock hazard.</p> <p>c) A fixed wiring terminal shall be prevented from turning by means other than friction alone.</p> <p>d) If terminals of unequal sizes are provided because of unbalanced loads, each terminal shall be sized to accept the appropriate conductor but based on the total current that will be carried by the conductor connected to the terminal.</p> <p>e) A field wiring terminal intended solely for connection of equipment grounding conductor shall be capable of securing a conductor of the size acceptable for the particular situation.</p> | 110-14, 110-14(a), 110-14(b) |
| 30 | <p>Flammability requirements for large surfaces</p> <p>An external surface of combustible material having an exposed area of greater than 0.9 m^2 or a single dimension greater than 1.80 m shall have a flame spread rating of 200 or less when tested in accordance with either:</p> <ul style="list-style-type: none"> – the Standard for Tests for Surface Burning Characteristics of Building Materials, UL 723, or ASTM E84; or, – the radiant panel furnace method in ASTM E162. The flame spread rating as determined by this method is the average value based on tests of six samples representative of the wall thickness used. <p>The limits mentioned refer to the exposed surface area of a single unbroken section. If two sides of a single piece are exposed, only the larger side is to be considered in computing the area.</p> <p>A material with a flame spread rating higher than 200 can be used as the exterior finish or covering on any portion of the enclosure, guard or cabinet if the flame spread rating of the combination of the base material and finish or covering has a flame spread rating of 200.</p> | NFPA 75 & National Building Code UL 746C |

| Clause No. of UL 60335-1 | Topic/summary | NEC | | | | | | | | | | | | | | | | | | | | | |
|--------------------------|---|--------------------|---|--|-----|--------------------|--------------------|---------|-----------|---------------|-------|------------|----|-------|-------------|----|---|------|----|---|------|----|----------|
| 25, 26 | <p>Wire bending space at field wiring terminals</p> <p>There shall be adequate room in a wiring compartment to properly make the field connections. The distance between any pressure terminal connector intended for field wiring and the wall of the enclosure shall be as indicated in the table given below. However, a shorter distance is acceptable where the wall or other obstruction lies outside of the area occupied by the conductor that is bent or deflected to a radius not less than given in the table.</p> <p style="text-align: center;">Minimum wire bending space</p> <table border="1" style="margin-left: auto; margin-right: auto;"> <thead> <tr> <th data-bbox="613 533 732 558">Size of wire</th> <th colspan="2" data-bbox="829 533 1243 558">Minimum bending space - terminal to wall</th> </tr> <tr> <th data-bbox="646 579 699 604">AWG</th> <th data-bbox="927 569 992 604">(mm²)</th> <th data-bbox="1170 579 1208 604">mm</th> </tr> </thead> <tbody> <tr> <td data-bbox="630 625 699 651">14 – 10</td> <td data-bbox="911 625 1008 651">2.1 – 5.3</td> <td data-bbox="1127 625 1252 651">Not specified</td> </tr> <tr> <td data-bbox="646 672 683 697">8 – 6</td> <td data-bbox="911 672 1008 697">8.4 – 13.3</td> <td data-bbox="1175 672 1203 697">40</td> </tr> <tr> <td data-bbox="646 718 683 743">4 – 3</td> <td data-bbox="906 718 1013 743">21.2 – 26.7</td> <td data-bbox="1175 718 1203 743">55</td> </tr> <tr> <td data-bbox="667 764 678 789">2</td> <td data-bbox="938 764 980 789">33.6</td> <td data-bbox="1175 764 1203 789">65</td> </tr> <tr> <td data-bbox="667 810 678 835">1</td> <td data-bbox="938 810 980 835">42.4</td> <td data-bbox="1175 810 1203 835">80</td> </tr> </tbody> </table> | Size of wire | Minimum bending space - terminal to wall | | AWG | (mm ²) | mm | 14 – 10 | 2.1 – 5.3 | Not specified | 8 – 6 | 8.4 – 13.3 | 40 | 4 – 3 | 21.2 – 26.7 | 55 | 2 | 33.6 | 65 | 1 | 42.4 | 80 | 373-6(b) |
| Size of wire | Minimum bending space - terminal to wall | | | | | | | | | | | | | | | | | | | | | | |
| AWG | (mm ²) | mm | | | | | | | | | | | | | | | | | | | | | |
| 14 – 10 | 2.1 – 5.3 | Not specified | | | | | | | | | | | | | | | | | | | | | |
| 8 – 6 | 8.4 – 13.3 | 40 | | | | | | | | | | | | | | | | | | | | | |
| 4 – 3 | 21.2 – 26.7 | 55 | | | | | | | | | | | | | | | | | | | | | |
| 2 | 33.6 | 65 | | | | | | | | | | | | | | | | | | | | | |
| 1 | 42.4 | 80 | | | | | | | | | | | | | | | | | | | | | |
| 25, 26 | <p>Volume of field wiring compartments</p> <p>Wiring compartments shall be of sufficient size to provide free space for all conductors enclosed in the box.</p> <p>a) The volume of field wiring compartment provided with pigtail leads for connection to the main supply shall not be less than in the table below.</p> <p style="text-align: center;">Minimum size of field wiring compartment</p> <table border="1" style="margin-left: auto; margin-right: auto;"> <thead> <tr> <th data-bbox="613 1150 732 1176">Size of Lead</th> <th colspan="2" data-bbox="829 1150 1243 1203">Wire space within compartment for each lead</th> </tr> <tr> <th data-bbox="646 1224 699 1249">AWG</th> <th data-bbox="927 1213 992 1249">(mm²)</th> <th data-bbox="1154 1213 1219 1249">(cm³)</th> </tr> </thead> <tbody> <tr> <td data-bbox="662 1270 683 1295">14</td> <td data-bbox="943 1270 976 1295">2.1</td> <td data-bbox="1175 1270 1203 1295">35</td> </tr> <tr> <td data-bbox="662 1316 683 1341">12</td> <td data-bbox="943 1316 976 1341">3.3</td> <td data-bbox="1175 1316 1203 1341">40</td> </tr> <tr> <td data-bbox="662 1362 683 1388">10</td> <td data-bbox="943 1362 976 1388">5.3</td> <td data-bbox="1175 1362 1203 1388">45</td> </tr> <tr> <td data-bbox="667 1409 678 1434">8</td> <td data-bbox="943 1409 976 1434">8.4</td> <td data-bbox="1175 1409 1203 1434">50</td> </tr> <tr> <td data-bbox="667 1455 678 1480">6</td> <td data-bbox="938 1455 980 1480">13.3</td> <td data-bbox="1175 1455 1203 1480">55</td> </tr> </tbody> </table> <p>b) A terminal compartment intended for connection of a supply raceway shall be fixed to the unit in a way so that it is resistant to turning.</p> <p>c) Field installation of any circuit conductors shall be separated by barriers from other field and factory installed conductors unless the conductors of both the circuits are rated for the highest voltage in either circuit.</p> | Size of Lead | Wire space within compartment for each lead | | AWG | (mm ²) | (cm ³) | 14 | 2.1 | 35 | 12 | 3.3 | 40 | 10 | 5.3 | 45 | 8 | 8.4 | 50 | 6 | 13.3 | 55 | 370-16 |
| Size of Lead | Wire space within compartment for each lead | | | | | | | | | | | | | | | | | | | | | | |
| AWG | (mm ²) | (cm ³) | | | | | | | | | | | | | | | | | | | | | |
| 14 | 2.1 | 35 | | | | | | | | | | | | | | | | | | | | | |
| 12 | 3.3 | 40 | | | | | | | | | | | | | | | | | | | | | |
| 10 | 5.3 | 45 | | | | | | | | | | | | | | | | | | | | | |
| 8 | 8.4 | 50 | | | | | | | | | | | | | | | | | | | | | |
| 6 | 13.3 | 55 | | | | | | | | | | | | | | | | | | | | | |

DVE D1 *Add a new annex DVE as follows*

Annex DVE
(Normative)

UL Leakage Current Requirements

DVE.1 Definitions

DVE.1.1 The following definitions apply to the requirements contained in DVE.2.

DVE.1.2 ACCESSIBLE – Able to be contacted by an accessibility probe.

DVE.1.3 APPLIANCE – Utilization equipment that uses electrical energy for some function.

DVE.1.4 EXPOSED – Visible but not necessarily able to be contacted by an accessibility probe.

DVE.1.5 LEAKAGE CURRENT – Electric current which flows through a person upon contact between ACCESSIBLE parts of an APPLIANCE and:

- a) Ground, or
- b) Other ACCESSIBLE parts of the APPLIANCE.

DVE.1.6 MEASUREMENT INDICATION UNIT (MIU) – The output voltage across the meter, in millivolts RMS, in the measurement instrument in Figure DVE.1.6.1, divided by 500 ohms. (The instrument indication is equal to the RMS value in milliamperes when the frequency is 60 Hz (sinusoidal current). The reading may not be a direct indication of the RMS or other common amplitude quantifier of LEAKAGE CURRENT when the LEAKAGE CURRENT is of complex waveform or frequency other than 50 or 60 Hz.)

Figure DVE.1.6.1 D1 Addition:

Figure DVE.1.6.1 – Measurement instrument for reaction (leakage) current

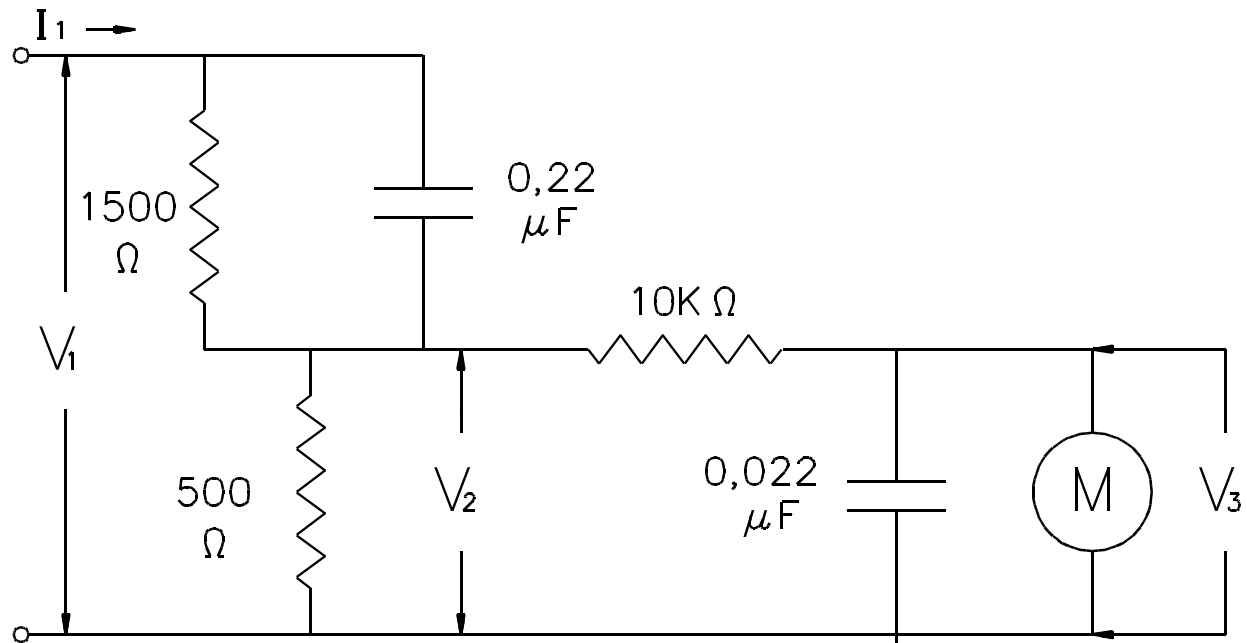

S3263D

Note – Detailed specifications and guidance for the calibration of this instrument are given in the American National Standard for Leakage Current for Appliances, ANSI C101-1992.

DVE.2 Leakage Current

DVE.2.1 A cord-connected product rated for a nominal 480-volt or less supply shall be tested in accordance with DVE.2.2 – 2.7. LEAKAGE CURRENT shall not be more than:

- a) 0.5 MIU for a two-wire cord-and plug-connected APPLIANCE,
- b) 0.5 MIU for a three-wire (including grounding conductor) cord-and plug-connected PORTABLE APPLIANCE, and
- c) 0.75 MIU for a three-wire (including grounding conductor) cord-and plug-connected stationary or FIXED APPLIANCE.

DVE.2.1.1: Exception to DVE.2.1: The LEAKAGE CURRENT of an APPLIANCE incorporating a sheath type heating element is to be monitored during heat-up and cool-down and shall not exceed 2.5 MIU during the first 5 minutes of energizing the APPLIANCE. At the end of this time, the LEAKAGE CURRENT shall be not more than the 0.5 MIU or 0.75 MIU limit, as applicable.

DVE.2.1.2: Exception to DVE.2.1: Conductive parts of an APPLIANCE that comply with the following conditions and that have a LEAKAGE CURRENT greater than specified in (a), (b), or (c) shall have a LEAKAGE CURRENT from simultaneously ACCESSIBLE parts to the grounded supply conductor no greater than 3.5 MIU. The LEAKAGE CURRENT between simultaneously ACCESSIBLE parts shall not exceed 0.5 MIU.

- 1) The product requires electromagnetic interference (EMI) suppression filtering for compliance with other requirements, such as Federal Communications Commission (FCC) Regulations;*
- 2) The product is equipped with a grounding type SUPPLY CORD and plug;*
- 3) There is a low probability that a path for available current through the body will exist in the expected environment. If the available current flows to ground, this will involve consideration of the probability that the user will be grounded during the use of the product;*
- 4) There is a low probability that high leakage conductive parts will be contacted during normal use of the product;*
- 5) The probability of injury resulting from an involuntary reaction is small.*

DVE.2.1.3: For an appliance that upon loss-of grounding, dependably disconnects all sources that can produce LEAKAGE CURRENT, the LEAKAGE CURRENT to ground shall not exceed 5 MIU with the grounding conductor open and with the loss-of-grounding circuit disabled. The LEAKAGE CURRENT between simultaneously ACCESSIBLE parts on the APPLIANCE shall not be more than 5 MIU.

DVE.2.2 All ACCESSIBLE conductive parts are to be tested for LEAKAGE CURRENTS. LEAKAGE CURRENTS from these parts are to be measured to the grounded supply conductor individually as well as collectively if simultaneously ACCESSIBLE, and from one part to another if simultaneously ACCESSIBLE. A part is considered to be ACCESSIBLE unless it is guarded by an enclosure that is acceptable for protection against the risk of electric shock as defined in Section 8. Conductive parts are considered to be simultaneously ACCESSIBLE when they can be readily contacted by one or both hands of a person at the same time. These measurements do not apply to terminals operating at voltages that are not considered to involve a risk of electric shock. When all ACCESSIBLE conductive parts are bonded together and connected to the grounding conductor of the power-SUPPLY CORD, the LEAKAGE CURRENT can be measured between the grounding conductor of the product and the grounded supply conductor. When ACCESSIBLE dead metal parts of a product are connected to the neutral supply conductor, this connection is to be opened during the test.

DVE.2.3 When a conductive part other than metal is used for an enclosure or part of an enclosure, LEAKAGE CURRENT is to be measured using a metal foil with an area of 10 by 20 centimeters in contact with the surface. When the conductive surface has an area less than 10 by 20 centimeters, the metal foil is to be the same size as the surface. The metal foil is to conform to the shape of the surface but is not to remain in place long enough to affect the temperature of the product.

DVE.2.4 Typical measurement circuits for LEAKAGE CURRENT with the ground connection open are illustrated in Figure DVE.2.4.1. The measurement instrument is defined in Figure DVE.1.6.1. The meter that is actually used for a measurement need only indicate the same numerical value for a particular measurement as would the defined instrument; it need not have all the attributes of the defined instrument. Over the frequency range 20 Hz to 1 MHz with sinusoidal currents, the performance of the instrument is to be as follows:

- a) The measured ratio V_1/I_1 with sinusoidal voltages shall be close to the ratio V_1/I_1 calculated with the resistance and capacitance values of the measurement instrument shown in Figure DVE.1.6.1.
- b) The measured ratio V_3/I_1 with sinusoidal voltages shall be close to the ratio V_3/I_1 calculated with the resistance and capacitance values of the measurement instrument shown in Figure DVE.1.6.1. V_3 is to be measured by the meter M in the measuring instrument. The reading of meter M in RMS volts is converted to MIU by dividing the reading by 500 S and then multiplying the quotient by 1 000. The mathematic equivalent is to simply multiply the RMS voltage reading by 2.

Figure DVE.2.4.1 D1 Addition:

Figure DVE.2.4.1 – Typical leakage-current measurement circuits

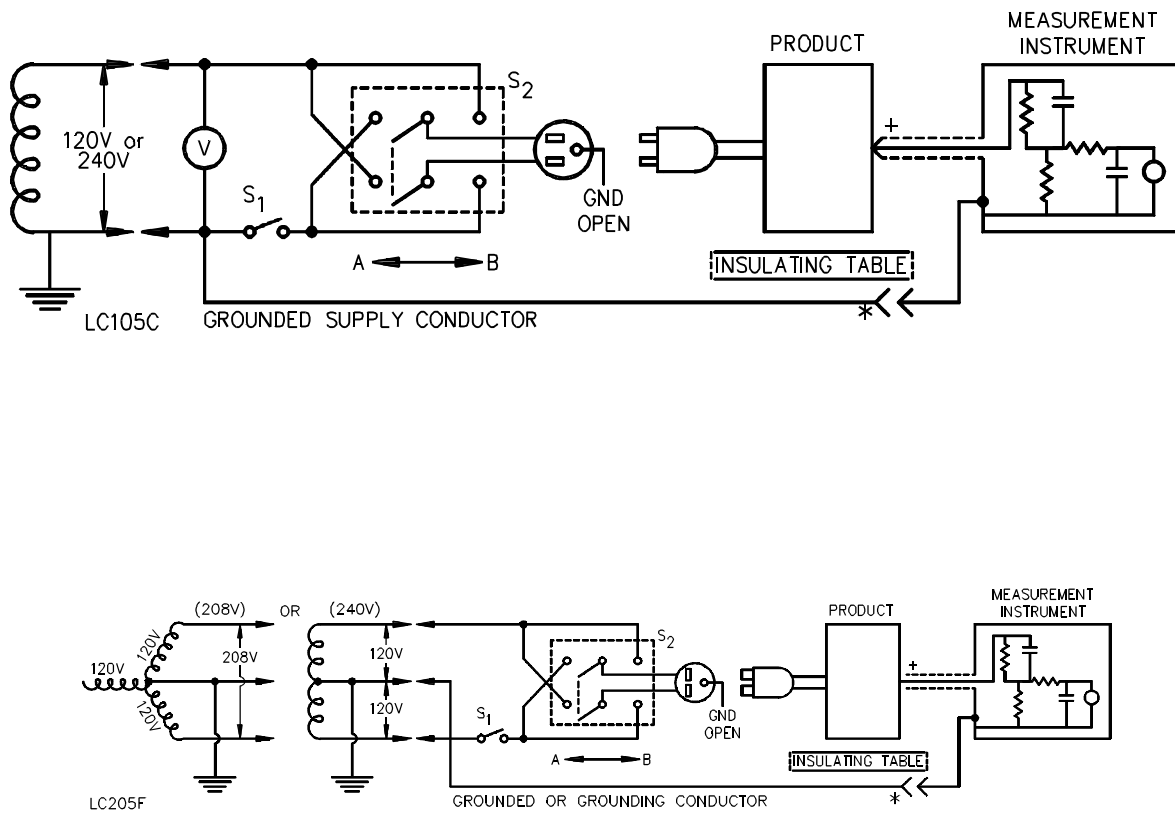

Product intended for connection to a 3-wire 208-volt or a 3-wire 240-volt grounded neutral power supply. See DVE.2.6 and DVE.2.7.

- + – Probe with shielded lead.
- * – Separated and used as a clip when measuring currents from one part of appliance to another.

DVE.2.5 Unless the measurement instrument is being used to measure leakage current from one part of a product to another, it is to be connected between ACCESSIBLE parts and the supply conductor connected to ground (the grounded or grounding conductor) that has the least extraneous voltages introduced from other equipment operated on the same supply. For products with one supply conductor grounded, it is likely to be the grounded supply conductor.

DVE.2.6 When there is no grounded conductor connected to the product under test (for example, a 240-volt, 2-conductor product supplied by a 120/240 volt source), then the instrument return lead may be connected to either the grounded or grounding conductor of the supply depending on the other electrical loads connected to the branch circuit and operating at the time the test is conducted. Use the conductor introducing the least extraneous voltage, as indicated by the lowest LEAKAGE CURRENT reading. In environments having considerable extraneous voltage introduced, an isolating transformer can reduce the effects of extraneous voltages.

DVE.2.7 A sample of a product is to be tested for LEAKAGE CURRENT starting with the as received condition – the as received condition being without prior energization, except as may occur as part of the production-line testing. The supply voltage is to be adjusted to RATED VOLTAGE.

The test sequence is to be as follows, with reference to the Figure DVE.2.4.1 measurement circuit:

- a) With switch S1 open, the product is to be connected to the measurement circuit. LEAKAGE CURRENT is to be measured using both positions of switch S2 and with the product switching devices in all their normal operating positions.
- b) Switch S1 is then to be closed, energizing the product. Within 5 seconds, the LEAKAGE CURRENT is to be measured using both positions of switch S2 and with the product switching devices in all their normal operating positions.
- c) LEAKAGE CURRENT is to be monitored until thermal stabilization. Both positions of switch S2 are to be used in determining this measurement. Thermal stabilization is to be obtained by operation as in the normal temperature test.
- d) The LEAKAGE CURRENT is also to be monitored with switch S1 open while the product is at operating temperature and while cooling

DVE.2.8 Normally a sample will be subjected to the entire LEAKAGE CURRENT test, as specified in DVE.2.7, without interruption for other tests. With the concurrence of those concerned, the LEAKAGE CURRENT test is not prohibited from being interrupted to conduct other nondestructive tests.