

# **ATX / ATX12V**

# **Power Supply Design Guide**

**Version 1.2**

---

## **IMPORTANT INFORMATION AND DISCLAIMERS**

1. INTEL CORPORATION (AND ANY CONTRIBUTOR) MAKES NO WARRANTIES WITH REGARD TO THIS DOCUMENT AND IN PARTICULAR DOES NOT WARRANT OR REPRESENT THAT THIS DOCUMENT OR ANY PRODUCTS MADE IN CONFORMANCE WITH IT WILL WORK IN THE INTENDED MANNER. NOR DOES INTEL (OR ANY CONTRIBUTOR) ASSUME RESPONSIBILITY FOR ANY ERRORS THAT THE DOCUMENT MAY CONTAIN OR HAVE ANY LIABILITIES OR OBLIGATIONS FOR DAMAGES INCLUDING, BUT NOT LIMITED TO, SPECIAL, INCIDENTAL, INDIRECT, PUNITIVE, OR CONSEQUENTIAL DAMAGES WHETHER ARISING FROM OR IN CONNECTION WITH THE USE OF THIS DOCUMENT IN ANY WAY.
2. NO REPRESENTATIONS OR WARRANTIES ARE MADE THAT ANY PRODUCT BASED IN WHOLE OR IN PART ON THE ABOVE DOCUMENT WILL BE FREE FROM DEFECTS OR SAFE FOR USE FOR ITS INTENDED PURPOSE. ANY PERSON MAKING, USING OR SELLING SUCH PRODUCT DOES SO AT HIS OR HER OWN RISK.
3. THE USER OF THIS DOCUMENT HEREBY EXPRESSLY ACKNOWLEDGES THAT THE DOCUMENT IS PROVIDED AS IS, AND THAT INTEL CORPORATION (AND ANY CONTRIBUTOR) MAKES NO REPRESENTATIONS, EXTENDS NO WARRANTIES OF ANY KIND, EITHER EXPRESS OR IMPLIED, ORAL OR WRITTEN, INCLUDING ANY WARRANTY OF MERCHANTABILITY OR FITNESS FOR A PARTICULAR PURPOSE, OR WARRANTY OR REPRESENTATION THAT THE DOCUMENT OR ANY PRODUCT OR TECHNOLOGY UTILIZING THE DOCUMENT OR ANY SUBSET OF THE DOCUMENT WILL BE FREE FROM ANY CLAIMS OF INFRINGEMENT OF ANY INTELLECTUAL PROPERTY, INCLUDING PATENTS, COPYRIGHT AND TRADE SECRETS NOR DOES INTEL (OR ANY CONTRIBUTOR) ASSUME ANY OTHER RESPONSIBILITIES WHATSOEVER WITH RESPECT TO THE DOCUMENT OR SUCH PRODUCTS.
4. NO LICENSE, EXPRESS OR IMPLIED, BY ESTOPPEL OR OTHERWISE, TO ANY INTELLECTUAL PROPERTY RIGHTS IS GRANTED HEREIN.

Copyright © 2000 Intel Corporation. All rights reserved.

Version 1.1

† Third-party brands and names are the property of their respective owners.

## **Revision History**

<b>Version</b>	<b>Summary of Changes</b>	<b>Date</b>
1.0	Initial Release	Feb. 2000
1.1	Increase 3.3 V current; add more explanation for power sharing; do minor edits and format fixes	Aug. 2000
1.2	Section 3.2.3 Typical Power Distribution. Change +5V loading on all power supplies distribution tables defined in DG to 0.3A  Section 3.3.2 PS_ON# . Add text "The power supply should not latch into a shutdown state when PS_ON# is driven active by pulses between 10ms to 100ms during the decay of the power rails."  Section 3.2.3.2 Remove -5V from all power distribution tables.	

# Contents

---

<b>1. Introduction.....</b>	<b>6</b>
1.1. Scope .....	6
1.2. New for ATX12V as Compared with ATX Power Supply .....	6
1.2.1. ATX12V .....	6
1.2.2. Increased +5 VSB Current .....	7
<b>2. Applicable Documents .....</b>	<b>8</b>
<b>3. Electrical .....</b>	<b>9</b>
3.1. AC Input .....	9
3.1.1. Input Overcurrent Protection .....	9
3.1.2. Inrush Current Limiting .....	9
3.1.3. Input Undervoltage .....	9
3.1.4. Immunity .....	10
3.1.5. Catastrophic Failure Protection .....	10
3.2. DC Output .....	10
3.2.1. DC Voltage Regulation .....	10
3.2.2. Remote Sensing .....	11
3.2.3. Typical Power Distribution .....	11
3.2.4. Power Limit .....	14
3.2.5. Efficiency .....	14
3.2.6. Output Ripple/Noise .....	15
3.2.7. Output Transient Response .....	16
3.2.8. Capacitive Load .....	17
3.2.9. Closed-loop Stability .....	17
3.2.10. +5 VDC / +3.3 VDC Power Sequencing .....	17
3.2.11. Voltage Hold-up Time .....	17
3.3. Timing / Housekeeping / Control .....	18
3.3.1. PWR_OK .....	18
3.3.2. PS_ON# .....	19
3.3.3. +5 VSB .....	20
3.3.4. Power-on Time .....	20
3.3.5. Risetime .....	20
3.3.6. Overshoot at Turn-on / Turn-off .....	20
3.3.7. Reset after Shutdown .....	21
3.3.8. +5 VSB at AC Power-down .....	21
3.4. Output Protection .....	21
3.4.1. Overvoltage Protection .....	21
3.4.2. Short-circuit Protection .....	21
3.4.3. No-load Operation .....	22
3.4.4. Overcurrent Protection .....	22
3.4.5. Overtemperature Protection .....	22
3.4.6. Output Bypass .....	22

<b>4. Mechanical .....</b>	<b>23</b>
4.1. Labeling / Marking .....	23
4.2. Physical Dimensions .....	23
4.3. Airflow / Fan .....	26
4.4. AC Connector.....	27
4.5. DC Connectors.....	27
4.5.1. ATX Main Power Connector .....	28
4.5.2. +12 V Power Connector (for ATX12V Configurations Only).....	29
4.5.3. Auxiliary Power Connector for Configurations with +3.3 VDC Output > 18 A or +5 V Output > 24 A .....	29
4.5.4. Peripheral Connector(s) .....	29
4.5.5. Floppy Drive Connector .....	29
<b>5. Environmental.....</b>	<b>30</b>
5.1. Temperature.....	30
5.2. Thermal Shock (Shipping).....	30
5.3. Humidity .....	30
5.4. Altitude .....	30
5.5. Mechanical Shock .....	30
5.6. Random Vibration.....	31
5.7. Acoustics .....	31
<b>6. Electromagnetic Compatibility .....</b>	<b>32</b>
6.1. EMI .....	32
6.2. Input Line Current Harmonic Content and Line Flicker .....	32
6.3. Magnetic Leakage Fields .....	32
<b>7. Reliability.....</b>	<b>33</b>
7.1. Component Derating .....	33
7.2. Mean Time Between Failures (MTBF) .....	33
<b>8. Safety.....</b>	<b>34</b>
8.1. North America .....	34
8.2. International.....	35
8.3. Proscribed Materials.....	35

## Figures

Figure 1. Differential Noise Test Setup.....	16
Figure 2. Power Supply Timing.....	18
Figure 3. PS_ON# Signal Characteristics.....	19
Figure 4. Power Supply Dimensions for Chassis in Which the P/S Does Not Cool Processor .....	24
Figure 5. Power Supply Dimensions for Chassis in Which the P/S Cools the Processor .....	25
Figure 6. ATX and ATX12V Power Supply Connectors.....	28

## Tables

Table 1. Power Supply Feature Summary, ATX versus ATX12V.....	7
Table 2. AC Input Line Requirements.....	9
Table 3. DC Output Voltage Regulation .....	10
Table 4. Typical Power Distribution for a 160 W ATX Configuration .....	11
Table 5. Typical Power Distribution for a 200 W ATX Configuration .....	12
Table 6. Typical Power Distribution for a 250 W ATX Configuration .....	12
Table 7. Typical Power Distribution for a 300 W ATX Configuration .....	12
Table 8. Typical Power Distribution for a 200 W ATX12V Configuration.....	13
Table 9. Typical Power Distribution for a 250 W ATX12V Configuration.....	13
Table 10. Typical Power Distribution for a 300 W ATX12V Configuration.....	14
Table 11. Energy Star Input Power Consumption .....	14
Table 12. DC Output Noise/Ripple .....	15
Table 13. DC Output Transient Step Sizes.....	16
Table 14. Output Capacitive Loads .....	17
Table 15. PWR_OK Signal Characteristics .....	18
Table 16. PS_ON# Signal Characteristics.....	19
Table 17. Overvoltage Protection .....	21
Table 18: Harmonic Limits, Class D equipment .....	32

# 1. Introduction

---

## 1.1. Scope

This document provides design suggestions and reference specifications for a family of power supplies that comply with the *ATX Specification, Version 2.03*\* for motherboards and chassis. It includes supplementary information not expressly detailed in the *ATX Specification*, such as information about the physical form factor of the power supply, cooling requirements, connector configuration, and pertinent electrical and signal timing specifications.

This document is provided as a convenience only and is not intended to replace the user's independent design and validation activity. It should not be inferred that all ATX or ATX12V power supplies must conform exactly to the content of this document. Neither are the design specifics described herein intended to support all possible system configurations, because system power supply needs vary widely depending on factors such as the application (that is, for desktop, workstation, or server), intended ambient environment (temperature, line voltage), or motherboard power requirements.

## 1.2. New for ATX12V as Compared with ATX Power Supply

This section briefly summarizes the major changes made to this document that now includes the ATX12V power supply. An earlier design guide covered only the ATX power supply. There are also a few changes from Version 1.0 to 1.1 (increased 3.3 V current, more explanation for power sharing).

### 1.2.1. ATX12V

A new superset of the original ATX power supply has been defined. Named “ATX12V,” this new power supply is comprised of a standard ATX unit plus the following enhancements:

- Increased +12 VDC output capability. Motherboard components with unique voltage requirements are increasingly expected to be powered via DC/DC converters off the +12 VDC power supply output. This trend is due primarily to the higher power conversion and transmission efficiencies of +12 VDC relative to +5 VDC or +3.3 VDC. ATX12V power supplies should be designed to accommodate these increased +12 VDC current requirements and to address associated issues such as cross-regulation, capacitive loading, transient surge tolerance, cable voltage drop, and cooling.

---

\* 2.03 is the current version of the *ATX Specification* as of this writing. Future references to the *ATX Specification* in this document imply version 2.03 or later, as applicable.

- **Power Connectors.** To enable the delivery of more +12 VDC current to the motherboard, a new 4-pin receptacle/header combination—the +12 V power connector—has been defined. **The presence of the +12 V power connector indicates that a power supply is ATX12V; the absence of the +12 V power connector indicates that a supply is ATX.** To allow for greater than 3.3 V current, the Aux Power Connector is recommended for ATX and ATX12V power supplies with 3.3 V current > 18 A. See Sections 3.2.3.2 and 4.5 for details on the +12 V and AUX power connector.

ATX12V power supplies are intended to be downward compatible with ATX power supplies. Consequently, it is required that an ATX12V power supply be able to provide the same typical +5 VDC and +3.3 VDC maximum continuous output currents as an ATX supply of the same total output power. To minimize cost, this may be accomplished via a load sharing arrangement, whereby the individual +12 VDC, +5 VDC, and +3.3 VDC output currents may trade off against each other but the combined total output power is constrained to not exceed a limit specified by the power supply designer. Such an approach can effectively support both +5 VDC- or +12 VDC-centric motherboards.

The standard ATX power supply definition will be maintained in parallel with ATX12V—despite the downward compatibility of ATX12V—because both offer distinct advantages to the industry:

- An ATX power supply supports motherboards that rely on DC/DC conversion from +5 VDC or +3.3 VDC only. This limitation and an initial volume advantage make it more attractive for focussed, cost-sensitive system platforms.
- An ATX12V power supply supports motherboards that rely on DC/DC conversion from either +12 VDC, +5 VDC, or +3.3 VDC, yielding more application flexibility for future platforms.

### 1.2.2. Increased +5 VSB Current

Trends in PC system power management solutions (for example, “Instantly Available PC,” “Suspend-to-RAM”) are driving a need for increased +5 VSB current capability for all ATX-family power supplies. The previous +5 VSB output requirement is being raised to 1.0 amps minimum, with 2.0 amps preferred. Recommendations for momentary peak current have also been added to enable USB “wake on” devices. See Section 3.3.3 for details.

**Table 1. Power Supply Feature Summary,  
ATX versus ATX12V**

	ATX	ATX12V
+12 V power connector	No	Yes
+5 VSB current	1.0 amps 1.5 Peak (required) 2.0 amps 2.5 Peak (recommended)	1.0 amps 1.5 Peak (required) 2.0 amps 2.5 Peak (recommended)

## 2. Applicable Documents

The latest revision in effect of the following documents forms a part of this document to the extent specified.

Document title	Description
AB13-94-146	European Association of Consumer Electronics Manufacturers (EACEM) Hazardous Substance List / Certification
ANSI C62.41-1991	IEEE Recommended Practice on Surge Voltages in Low-Voltage AC Circuits
ANSI C62.45-1992	IEEE Guide on Surge Testing for Equipment Connected to Low-Voltage AC Power Circuits
MIL-STD-105K	Quality Control
MIL-STD-217F	Reliability Predictions for Electronic Equipment
MIL-C-5541	Chemical Conversion Coatings on Aluminum and Aluminum Alloys
CSA C22.2 No.234, Level 3	Safety of Component Power Supplies (Intended for use with Electronic Data Processing Equipment and Office Machines)
CAN/CSA C22.2 No.950-95, 3 <sup>rd</sup> edition	Safety of Information Technology Equipment Including Electrical Business Equipment
UL 1950, 3 <sup>rd</sup> edition, without D3 Deviation	Safety of Information Technology Equipment Including Electrical Business Equipment
IEC 60950 plus A1, A2, A3, A4	Safety of Information Technology Equipment Including Business Equipment
EN 60950 plus A1, A2, A3, A4	Safety of Information Technology Equipment Including Business Equipment
EMKO-TSE (74-SEC) 207/94	Nordic national requirement in addition to EN 60950
CISPR 22:1997 3 <sup>rd</sup> edition EN 55022:1998	Limits and Methods of Measurements of Radio Interference Characteristics of Information Technology Equipment, Class B
ANSI C63.4 – 1992	American National Standard for Methods of Measurement of Radio-Noise Emissions from Low-Voltage Electrical and Electronic Equipment in the Range of 9 kHz to 40 GHz for EMI testing
EN 55024:1998	Information technology equipment—Immunity characteristics—Limits and methods of measurement
EN 61000-3-2	Electromagnetic compatibility (EMC)—Part 3: Limits—Section 2: Limits for harmonic current emissions, Class D
IEC 61000-4-	Electromagnetic compatibility (EMC) for industrial-process measurement and control equipment—Part 4: Testing and measurement techniques Section -2: Electrostatic discharge Section -3: Radiated, radio-frequency, electromagnetic field Section -4: Electrical fast transient / burst Section -5: Surge Section -6: Conducted disturbances, induced by radio-frequency fields Section -8: Power frequency magnetic fields Section -11: Voltage dips, short interruptions, and voltage variations
Japan Electric Association	Guidelines for the Suppression of Harmonics in Appliances and General Use Equipment
IEC Publication 417	International Graphic Symbol Standard
ISO Standard 7000	Graphic Symbols for Use on Equipment
CFR 47, Part 15, Subpart B	FCC Rules



## 3. Electrical

---

The electrical requirements that follow are to be met over the environmental ranges specified in Section 5 unless otherwise noted.

### 3.1. AC Input

Table 2 lists AC input voltage and frequency requirements for continuous operation. The power supply shall be capable of supplying full-rated output power over two input voltage ranges rated 100-127 VAC and 200-240 VAC rms nominal. The correct input range for use in a given environment may be either switch-selectable or autoranging. The power supply shall automatically recover from AC power loss. The power supply must be able to start up under peak loading at 90 VAC.

**Table 2. AC Input Line Requirements**

Parameter	Min.	Nom. <sup>(1)</sup>	Max.	Unit
V <sub>in</sub> (115 VAC)	90	115	135	VAC <sub>rms</sub>
V <sub>in</sub> (230 VAC)	180	230	265	VAC <sub>rms</sub>
V <sub>in</sub> Frequency	47	--	63	Hz

<sup>(1)</sup> Nominal voltages for test purposes are considered to be within ±1.0 V of nominal.

#### 3.1.1. Input Overcurrent Protection

The power supply shall incorporate primary fusing for input overcurrent protection to prevent damage to the power supply and meet product safety requirements. Fuses should be slow-blow-type or equivalent to prevent nuisance trips.

#### 3.1.2. Inrush Current Limiting

Maximum inrush current from power-on (with power on at any point on the AC sine) and including, but not limited to, three line cycles, shall be limited to a level below the surge rating of the input line cord, AC switch if present, bridge rectifier, fuse, and EMI filter components. Repetitive ON/OFF cycling of the AC input voltage should not damage the power supply or cause the input fuse to blow.

#### 3.1.3. Input Undervoltage

The power supply shall contain protection circuitry such that the application of an input voltage below the minimum specified in Section 3.1, Table 2, shall not cause damage to the power supply.

### 3.1.4. Immunity

At a minimum, a system and power supply typically must pass testing per the limits and methods described in EN 55024 prior to sale in many parts of the world. Additional requirements may depend on the design, product end use, target geography, customer, and other variables. Consult your company's Product Safety and Regulations department for more details.

### 3.1.5. Catastrophic Failure Protection

Should a component failure occur, the power supply should not exhibit any of the following:

- Flame
- Excessive smoke
- Charred PCB
- Fused PCB conductor
- Startling noise
- Emission of molten material

## 3.2. DC Output

### 3.2.1. DC Voltage Regulation

The DC output voltages shall remain within the regulation ranges shown in Table 3 when measured at the load end of the output connectors under all line, load, and environmental conditions. The voltage regulation limits shall be maintained under continuous operation for a period of time equal to or greater than the MTBF specified in Section 7.2 at any steady state temperature and operating conditions specified in Section 5.

**Table 3. DC Output Voltage Regulation**

Output	Range	Min.	Nom.	Max.	Unit
+12VDC <sup>(1)</sup>	±5%	+11.40	+12.00	+12.60	Volts
+5VDC	±5%	+4.75	+5.00	+5.25	Volts
+3.3VDC	±5%	+3.14	+3.30	+3.47	Volts
-5VDC	±10%	-4.50	-5.00	-5.50	Volts
-12VDC	±10%	-10.80	-12.00	-13.20	Volts
+5VSB	±5%	+4.75	+5.00	+5.25	Volts

<sup>(1)</sup> At +12 VDC peak loading, regulation at the +12 VDC output can go to ± 10%.

### 3.2.2. Remote Sensing

The +3.3 VDC output should have provisions for remote sensing to compensate for excessive cable drops. The default sense should be connected to pin 11 of the main power connector. The power supply should draw no more than 10 mA through the remote sense line to keep DC offset voltages to a minimum.

### 3.2.3. Typical Power Distribution

DC output power requirements and distributions will vary widely based on specific system options and implementation. Significant dependencies include the quantity and types of processors, memory, add-in card slots, and peripheral bays, as well as support for advanced graphics or other features. It is ultimately the responsibility of the designer to derive a power budget for a given target product and market.

Tables 4 through 10 provide sample power distributions and cross-loading diagrams as a reference only. The tabular data summarizes maximum and minimum loadings on each output, regardless of cross-regulation. The diagrams show typical assumptions for cross-loading: The area within each plotted perimeter represents the *power usage* of a motherboard and system platform. At a minimum, the power supply must have the capability to provide power for the area inside the plotted area. The power supply may provide additional margin for the area outside the perimeter. In each graph, the vertical line on the right side shows the recommended combined power from 3.3 V and 5 V; the upper horizontal line is the recommended 12 V power; and the total power is the power expected from all rails for any system configuration. The power supply will share power between the 5 V, 3.3 V, and 12 V to provide the maximum rated power under the possible loading conditions shown in each graph. It should not be inferred that all power supplies must conform to these tables, nor that a power supply designed to meet the information in the tables will work in all system configurations.

#### 3.2.3.1. ATX Configurations

**Table 4. Typical Power Distribution for a 160 W ATX Configuration**

Output	Min. Current (amps)	Max. Current (amps)	Peak Current (amps)
+12 VDC	0.0	6.0	8.0
+5 VDC	0.3	18.0	
+3.3 VDC	0.3	14.0	
-5 VDC	0.0	0.3	
-12 VDC	0.0	0.8	
+5 VSB	0.0	1.5	2.5

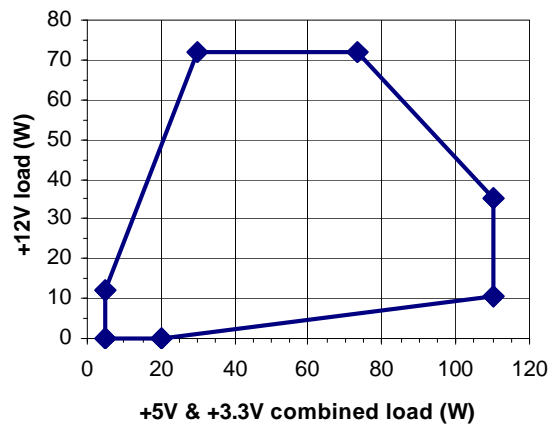

See graph at right for power sharing.

**Table 5. Typical Power Distribution for a 200 W ATX Configuration**

Output	Min. Current (amps)	Max. Current (amps)	Peak Current (amps)
+12 VDC	0.0	8.0	10.0
+5 VDC	0.3	21.0	
+3.3 VDC	0.3	14.0	
-5 VDC	0.0	0.3	
-12 VDC	0.0	0.8	
+5 VSB	0.0	1.5	2.5

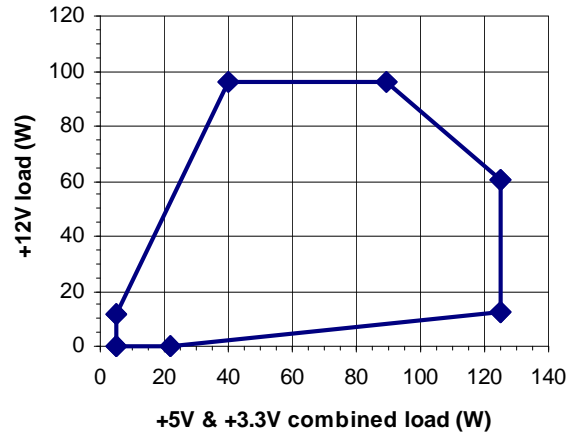

See graph at right for power sharing.

**Table 6. Typical Power Distribution for a 250 W ATX Configuration**

Output	Min. Current (amps)	Max. Current (amps)	Peak Current (amps)
+12 VDC	0.0	10.0	12.0
+5 VDC	0.3	25.0	
+3.3 VDC	0.3	16.0	
-5 VDC	0.0	0.3	
-12 VDC	0.0	0.8	
+5 VSB	0.0	1.5	2.5

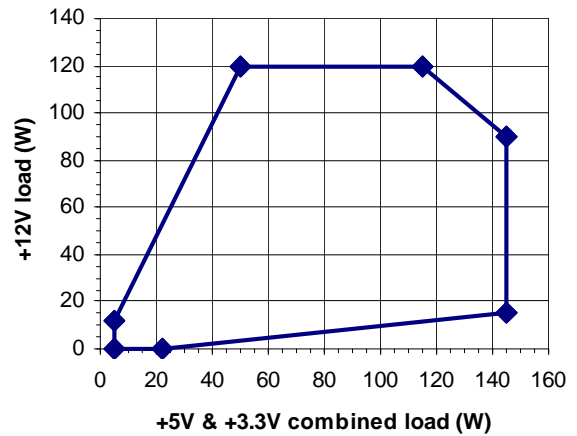

See graph at right for power sharing.

**Table 7. Typical Power Distribution for a 300 W ATX Configuration**

Output	Min. Current (amps)	Max. Current (amps)	Peak Current (amps)
+12 VDC	0.0	12.0	14.0
+5 VDC	0.3	30.0	
+3.3 VDC	0.3	20.0	
-5 VDC	0.0	0.3	
-12 VDC	0.0	0.8	
+5 VSB	0.0	1.5	2.5

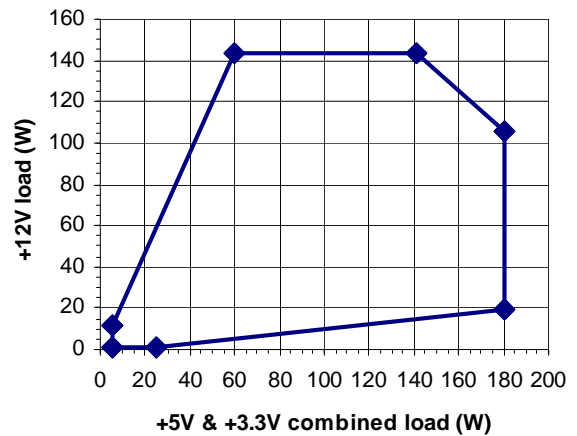

See graph at right for power sharing.

### 3.2.3.2. ATX12V Configurations

ATX12V power supplies—with their additional 2x2 +12V & Aux power connectors—are intended for applications where the motherboard demand for current exceeds the ATX main power connector capability of ~6 A per contact. In general, the +12 V power connector should not be implemented on any power supply with a total +12 VDC continuous output capability of less than 10 A.

**Table 8. Typical Power Distribution for a 200 W ATX12V Configuration**

Output	Min. Current (amps)	Max. Current (amps)	Peak Current (amps)
+12 VDC	0.0	10.0	12.0
+5 VDC	0.3	21.0	
+3.3 VDC	0.3	14.0	
-12 VDC	0.0	0.8	
+5 VSB	0.0	1.5	2.5

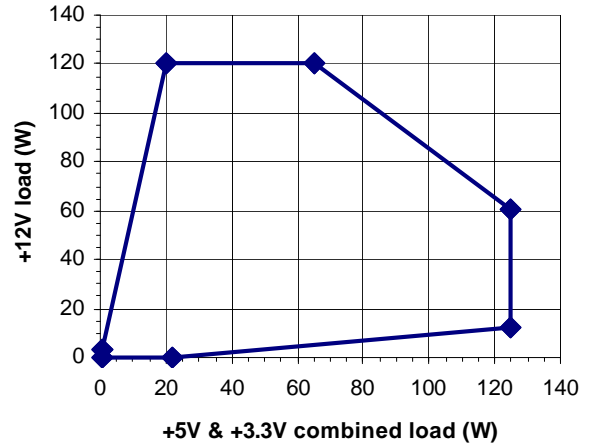

See graph at right for power sharing.

**Table 9. Typical Power Distribution for a 250 W ATX12V Configuration**

Output	Min. Current (amps)	Max. Current (amps)	Peak Current (amps)
+12 VDC	0.0	13.0	16.0
+5 VDC	0.3	25.0	
+3.3 VDC	0.3	20.0	
-12 VDC	0.0	0.8	
+5 VSB	0.0	1.5	2.5

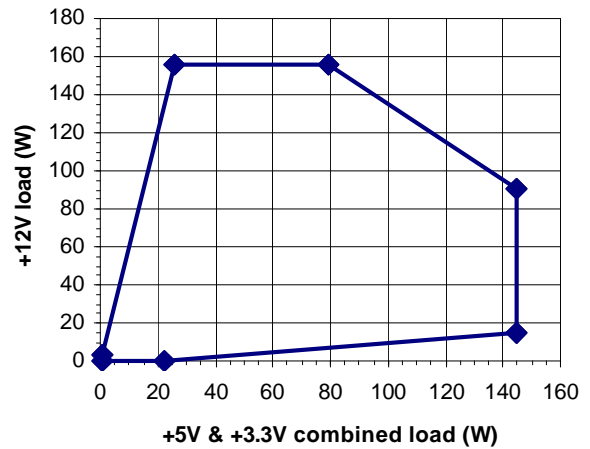

See graph at right for power sharing.

**Table 10. Typical Power Distribution for a 300 W ATX12V Configuration**

Output	Min. Current (amps)	Max. Current (amps)	Peak Current (amps)
+12 VDC	0.0	15.0	18.0
+5 VDC	0.3	30.0	
+3.3 VDC	0.3	28.0	
<hr/>			
-12 VDC	0.0	0.8	
+5 VSB	0.0	2.0	2.5

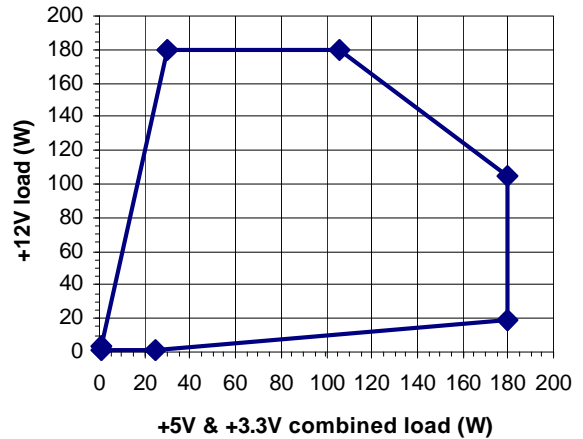

See graph at right for power sharing.

### 3.2.4. Power Limit

Under short-circuit or overload conditions, no output shall exceed 240 VA under any conditions including single component fault conditions, per IEC 60950 requirements.

### 3.2.5. Efficiency

#### 3.2.5.1. General

The power supply should be a minimum of 68% efficient under maximum rated load. The efficiency of the power supply should be met over the AC input range defined in Table 2, under the load conditions defined in Section 3.2.3, and under the temperature and operating conditions defined in Section 5.

#### 3.2.5.2. Energy Star

The “Energy Star” efficiency requirements of the power supply depend on the intended system configuration. In the low-power / sleep state (S1 or S3) the system should consume power in accordance with the values listed in Table 8.

**Table 11. Energy Star Input Power Consumption**

Maximum Continuous Power Rating of Power Supply	RMS Watts from the AC line in sleep/low-power mode
$\leq 200$ W	$\leq 15$ W
$> 200$ W $\leq 300$ W	$\leq 20$ W
$> 300$ W $\leq 350$ W	$\leq 25$ W
$> 350$ W $\leq 400$ W	$\leq 30$ W
$> 400$ W	10% of the maximum continuous output rating

**Note:** To help meet the “Energy Star” system requirements, it is recommended that the power supply have > 50% efficiency at light load and in standby mode.

### 3.2.5.3. Blue Angel, RAL-UZ 78

The +5VSB standby supply efficiency should be a minimum of 50% at 500 mA output. Standby efficiency is measured with the main outputs off and with PS\_ON# high. To meet Blue Angel requirements, the AC input power shall not exceed 5 W when the main outputs are in the “DC disabled” state with 500 mA load on +5VSB and a 230 VAC/50 Hz input.

### 3.2.6. Output Ripple/Noise

The output ripple/noise requirements listed in Table 12 should be met throughout the load ranges specified in Section 3.2.3 and under all input voltage conditions as specified in Section 3.1.

Ripple and noise are defined as periodic or random signals over a frequency band of 10 Hz to 20 MHz. Measurements shall be made with an oscilloscope with 20 MHz bandwidth. Outputs should be bypassed at the connector with a 0.1  $\mu$ F ceramic disk capacitor and a 10  $\mu$ F electrolytic capacitor to simulate system loading. See Figure 1.

**Table 12. DC Output Noise/Ripple**

Output	Max. Ripple & Noise (mV <sub>pp</sub> )
+12 VDC	120
+5 VDC	50
+3.3 VDC	50
-5 VDC	100
-12 VDC	120
+5 VSB	50

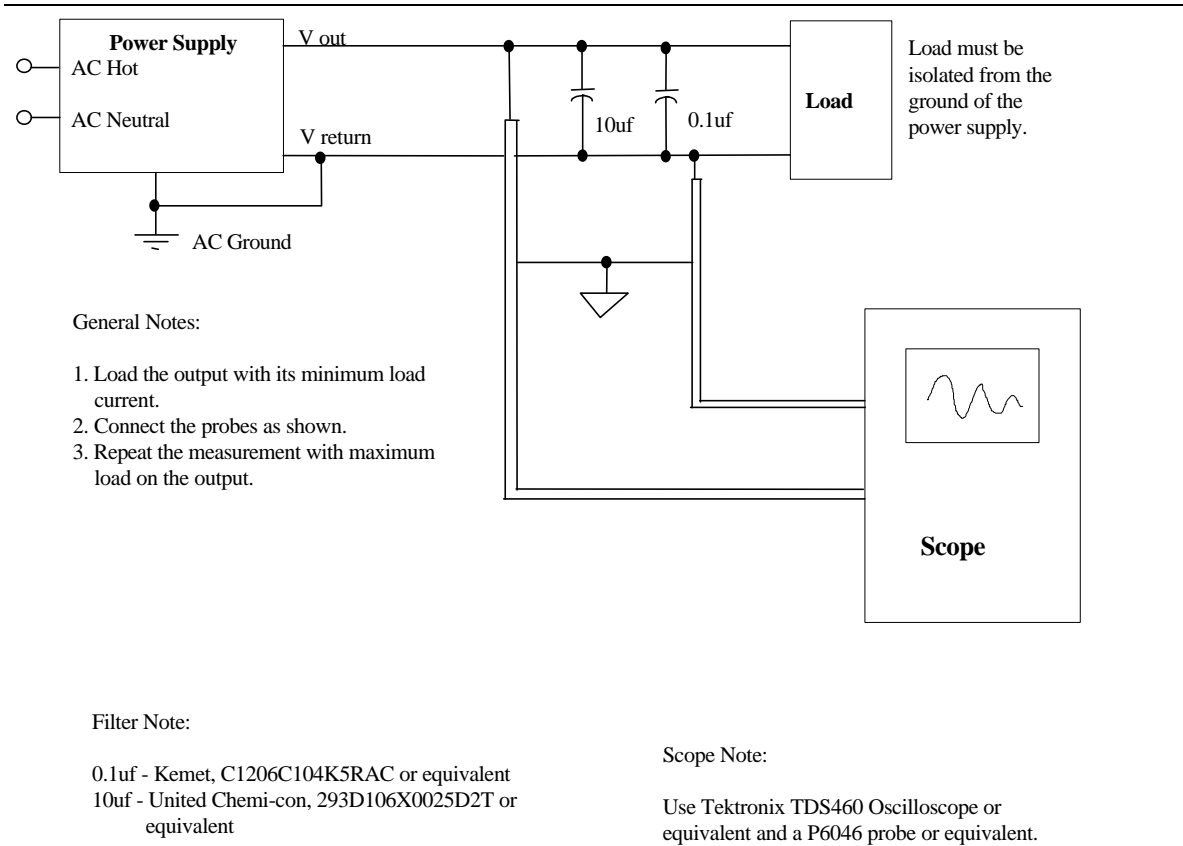

**Figure 1. Differential Noise Test Setup**

### 3.2.7. Output Transient Response

Table 13 summarizes the expected output transient step sizes for each output. The transient load slew rate is = 1.0 A/µs.

**Table 13. DC Output Transient Step Sizes**

Output	Max. step size (% of rated output amps per Sec 3.2.3) <sup>(1)</sup>	Max. step size (amps)
+12 VDC	50%	
+5 VDC	30%	
+3.3 VDC	30%	
-5 VDC		0.1 A
-12 VDC		0.1 A
+5 VSB		0.1 A

<sup>(1)</sup> For example, for a rated +5 VDC output of 18 A, the transient step would be 30% × 18 A = 5.4 A

Output voltages should remain within the regulation limits of Section 3.2.1, and the power supply should be stable when subjected to load transients per Table 13 from any steady state load, including any or all of the following conditions:



- Simultaneous load steps on the +12 VDC, +5 VDC, and +3.3 VDC outputs (all steps occurring in the same direction)
- Load-changing repetition rate of 50 Hz to 10 kHz
- AC input range per Section 3.1
- Capacitive loading per Table 14

### 3.2.8. Capacitive Load

The power supply should be able to power up and operate normally with the following capacitances simultaneously present on the DC outputs.

**Table 14. Output Capacitive Loads**

Output	ATX Capacitive load (mF)	ATX12V Capacitive load (mF)
+12 VDC	1,000	20,000
+5 VDC	10,000	10,000
+3.3 VDC	6,000	6,000
-5 VDC	350	350
-12 VDC	350	350
+5 VSB	350	350

### 3.2.9. Closed-loop Stability

The power supply shall be unconditionally stable under all line/load/transient load conditions including capacitive loads specified in Section 3.2.8. A minimum of 45 degrees phase margin and 10 dB gain margin is recommended at both the maximum and minimum loads.

### 3.2.10. +5 VDC / +3.3 VDC Power Sequencing

The +12 VDC and +5 VDC output levels must be equal to or greater than the +3.3 VDC output at all times during power-up and normal operation. The time between the +12 VDC or +5 VDC output reaching its minimum in-regulation level and +3.3 VDC reaching its minimum in-regulation level must be  $\leq 20$  ms.

### 3.2.11. Voltage Hold-up Time

The power supply should maintain output regulation per Section 3.2.1 despite a loss of input power at the low-end nominal range—115 VAC / 57 Hz or 230 VAC / 47 Hz—at maximum continuous output load as applicable for a minimum of 17 ms.

### 3.3. Timing / Housekeeping / Control

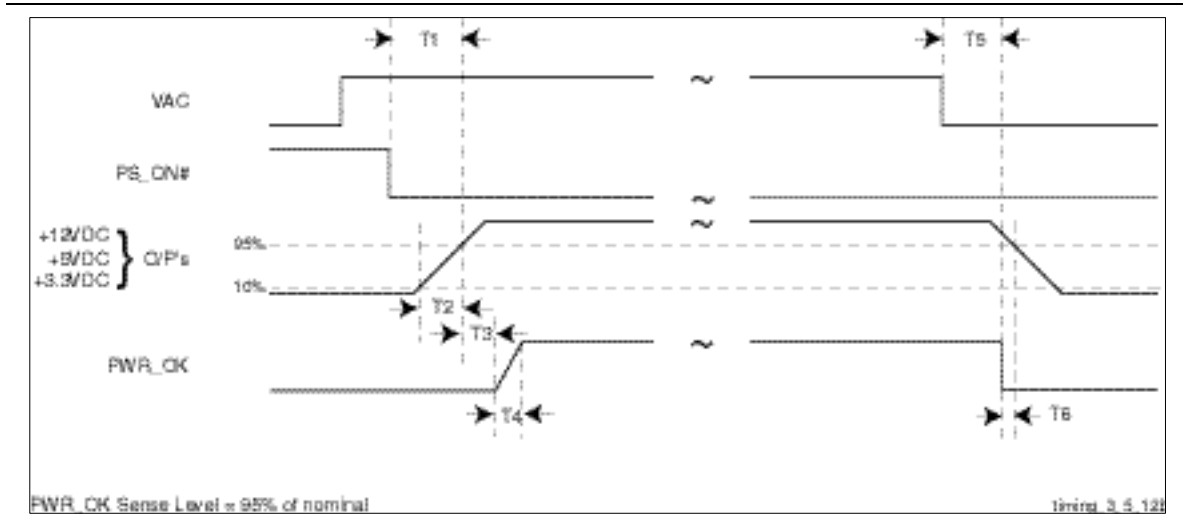

**Figure 2. Power Supply Timing**

Notes: T1 is defined in Section 3.3.4. T2 is defined in Section 3.3.5. T3, T4, T5, and T6 are defined in Table 15

#### 3.3.1. PWR\_OK

PWR\_OK is a “power good” signal. It should be asserted high by the power supply to indicate that the +12 VDC, +5VDC, and +3.3VDC outputs are above the undervoltage thresholds listed in Section 3.2.1 and that sufficient mains energy is stored by the converter to guarantee continuous power operation within specification for at least the duration specified in Section 3.2.11, “Voltage Hold-up Time.” Conversely, PWR\_OK should be de-asserted to a low state when any of the +12 VDC, +5 VDC, or +3.3 VDC output voltages falls below its undervoltage threshold, or when mains power has been removed for a time sufficiently long such that power supply operation cannot be guaranteed beyond the power-down warning time. The electrical and timing characteristics of the PWR\_OK signal are given in Table 15 and in Figure 2.

**Table 15. PWR\_OK Signal Characteristics**

Signal Type	+5 V TTL compatible
Logic level low	< 0.4 V while sinking 4 mA
Logic level high	Between 2.4 V and 5 V output while sourcing 200 $\mu$ A
High-state output impedance	1 k $\Omega$ from output to common
PWR_OK delay	100 ms < T <sub>3</sub> < 500 ms
PWR_OK risetime	T <sub>4</sub> $\leq$ 10 ms
AC loss to PWR_OK hold-up time	T <sub>5</sub> $\geq$ 16 ms
Power-down warning	T <sub>6</sub> $\geq$ 1 ms

### 3.3.2. PS\_ON#

PS\_ON# is an active-low, TTL-compatible signal that allows a motherboard to remotely control the power supply in conjunction with features such as soft on/off, Wake on LAN<sup>†</sup>, or wake-on-modem. When PS\_ON# is pulled to TTL low, the power supply should turn on the five main DC output rails: +12VDC, +5VDC, +3.3VDC, -5VDC, and -12VDC. When PS\_ON# is pulled to TTL high or open-circuited, the DC output rails should not deliver current and should be held at zero potential with respect to ground. PS\_ON# has no effect on the +5VSB output, which is always enabled whenever the AC power is present. Table 16 lists PS\_ON# signal characteristics.

The power supply shall provide an internal pull-up to TTL high. The power supply shall also provide debounce circuitry on PS\_ON# to prevent it from oscillating on/off at startup when activated by a mechanical switch. The DC output enable circuitry must be SELV-compliant.

The power supply shall not latch into a shutdown state when PS\_ON# is driven active by pulses between 10ms to 100ms during the decay of the power rails.

**Table 16. PS\_ON# Signal Characteristics**

	Min.	Max.
V <sub>IL</sub> , Input Low Voltage	0.0 V	0.8 V
I <sub>IL</sub> , Input Low Current (V <sub>in</sub> = 0.4 V)		-1.6 mA
V <sub>IH</sub> , Input High Voltage (I <sub>in</sub> = -200 μA)	2.0 V	
V <sub>IH</sub> open circuit, I <sub>in</sub> = 0		5.25 V

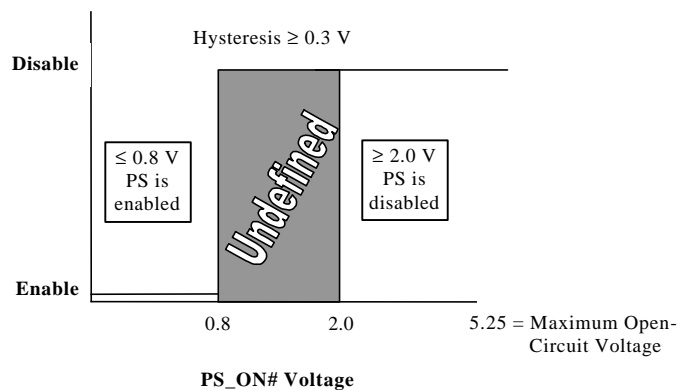

**Figure 3. PS\_ON# Signal Characteristics**

### 3.3.3. +5 VSB

+5 VSB is a standby supply output that is active whenever the AC power is present. It provides a power source for circuits that must remain operational when the five main DC output rails are in a disabled state. Example uses include soft power control, Wake on LAN, wake-on-modem, intrusion detection, or suspend state activities.

The +5 VSB output should be capable of delivering a minimum of 1.0 A at +5 V  $\pm$  5% to external circuits. Because trends indicate a growing demand for standby power, it is recommended that designs be scalable to 2.0 A to meet future needs. The power supply must be able to provide the required power during a "wake up" event. If an external USB device generates the event, there may be peak currents as high as 2.5A lasting no more than 500mS.

Overcurrent protection is required on the +5 VSB output regardless of the output current rating. This ensures the power supply will not be damaged if external circuits draw more current than the supply can provide.

### 3.3.4. Power-on Time

The power-on time is defined as the time from when PS\_ON# is pulled low to when the +12 VDC, +5 VDC, and +3.3 VDC outputs are within the regulation ranges specified in Section 3.2.1. The power-on time shall be less than 500 ms ( $T_1 < 500$  ms).

+5 VSB shall have a power-on time of two seconds maximum after application of valid AC voltages.

### 3.3.5. Risetime

The output voltages shall rise from  $\leq 10\%$  of nominal to within the regulation ranges specified in Section 3.2.1 within 0.1 ms to 20 ms ( $0.1 \text{ ms} \leq T_2 \leq 20 \text{ ms}$ ).

There must be a smooth and continuous ramp of each DC output voltage from 10% to 90% of its final set-point within the regulation band, while loaded as specified in Section 3.2.3. The smooth turn-on requires that, during the 10% to 90% portion of the rise time, the slope of the turn-on waveform must be positive and have a value of between 0 V/ms and  $[V_{\text{out,nominal}} / 0.1]$  V/ms. Also, for any 5 ms segment of the 10% to 90% risetime waveform, a straight line drawn between the end points of the waveform segment must have a slope  $\geq [V_{\text{out,nominal}} / 20]$  V/ms.

### 3.3.6. Overshoot at Turn-on / Turn-off

The output voltage overshoot upon the application or removal of the input voltage, or the assertion/deassertion of PS\_ON#, under the conditions specified in Section 3.1, shall be less than 10% above the nominal voltage. No voltage of opposite polarity shall be present on any output during turn-on or turn-off.

### 3.3.7. Reset after Shutdown

If the power supply latches into a shutdown state because of a fault condition on its outputs, the power supply shall return to normal operation only after the fault has been removed and the PS\_ON# (or AC input) has been cycled OFF/ON with a minimum OFF time of 1 second.

### 3.3.8. +5 VSB at AC Power-down

After AC power is removed, the +5 VSB standby voltage output should remain at its steady state value for the minimum hold-up time specified in Section 3.2.11 until the output begins to decrease in voltage. The decrease shall be monotonic in nature, dropping to 0.0 V. There shall be no other perturbations of this voltage at or following removal of AC power.

## 3.4. Output Protection

### 3.4.1. Overvoltage Protection

The overvoltage sense circuitry and reference shall reside in packages that are separate and distinct from the regulator control circuitry and reference. No single point fault shall be able to cause a sustained overvoltage condition on any or all outputs. The supply shall provide latch-mode overvoltage protection as defined in Table 17.

**Table 17. Overvoltage Protection**

Output	Min.	Nom.	Max.	Unit
+12 VDC	13.4	15.0	15.6	Volts
+5 VDC	5.74	6.3	7.0	Volts
+3.3 VDC	3.76	4.2	4.3	Volts

### 3.4.2. Short-circuit Protection

An output short circuit is defined as any output impedance of less than 0.1 ohms. The power supply shall shut down and latch off for shorting the +3.3 VDC, +5 VDC, or +12 VDC rails to return or any other rail. Shorts between main output rails and +5 VSB shall not cause any damage to the power supply. The power supply shall either shut down and latch off or fold back for shorting the negative rails. +5 VSB must be capable of being shorted indefinitely, but when the short is removed, the power supply shall recover automatically or by cycling PS\_ON#. The power supply shall be capable of withstanding a continuous short-circuit to the output without damage or overstress to the unit (for example, to components, PCB traces, connectors) under the input conditions specified in Section 3.1. The maximum short-circuit energy in any output shall not exceed 240 VA, per IEC 60950 requirements.

### **3.4.3. No-load Operation**

No damage or hazardous condition should occur with all the DC output connectors disconnected from the load. The power supply may latch into the shutdown state.

### **3.4.4. Overcurrent Protection**

Overload currents applied to each tested output rail will cause the output to trip before reaching or exceeding 240 VA. For testing purposes, the overload currents should be ramped at a minimum rate of 10 A/s starting from full load.

### **3.4.5. Overtemperature Protection**

The power supply may include an overtemperature protection sensor, which can trip and shut down the power supply at a preset temperature point. Such an overheated condition is typically the result of internal current overloading or a cooling fan failure. If the protection circuit is nonlatching, then it should have hysteresis built in to avoid intermittent tripping.

### **3.4.6. Output Bypass**

The output return may be connected to the power supply chassis. The return will be connected to the system chassis by the system components.

## 4. Mechanical

---

### 4.1. Labeling / Marking

The following is a noninclusive list of suggested markings for each power supply unit. Product regulation stipulations for sale into various geographies may impose additional labeling requirements.

- Manufacturer information: manufacturer's name, part number, and lot date code, etc., in human-readable text and/or bar code formats
- Nominal AC input operating voltages (100-127 VAC and 200-240 VAC) and current rating certified by all applicable safety agencies (Section 8)
- DC output voltages and current ratings
- Access warning text (“Do not remove this cover. Trained service personnel only. No user serviceable components inside.”) in English, German, Spanish, French, Chinese, and Japanese with universal warning markings

### 4.2. Physical Dimensions

The supply shall be enclosed and meet the physical outline shown in either Figure 4 or 5, as applicable.

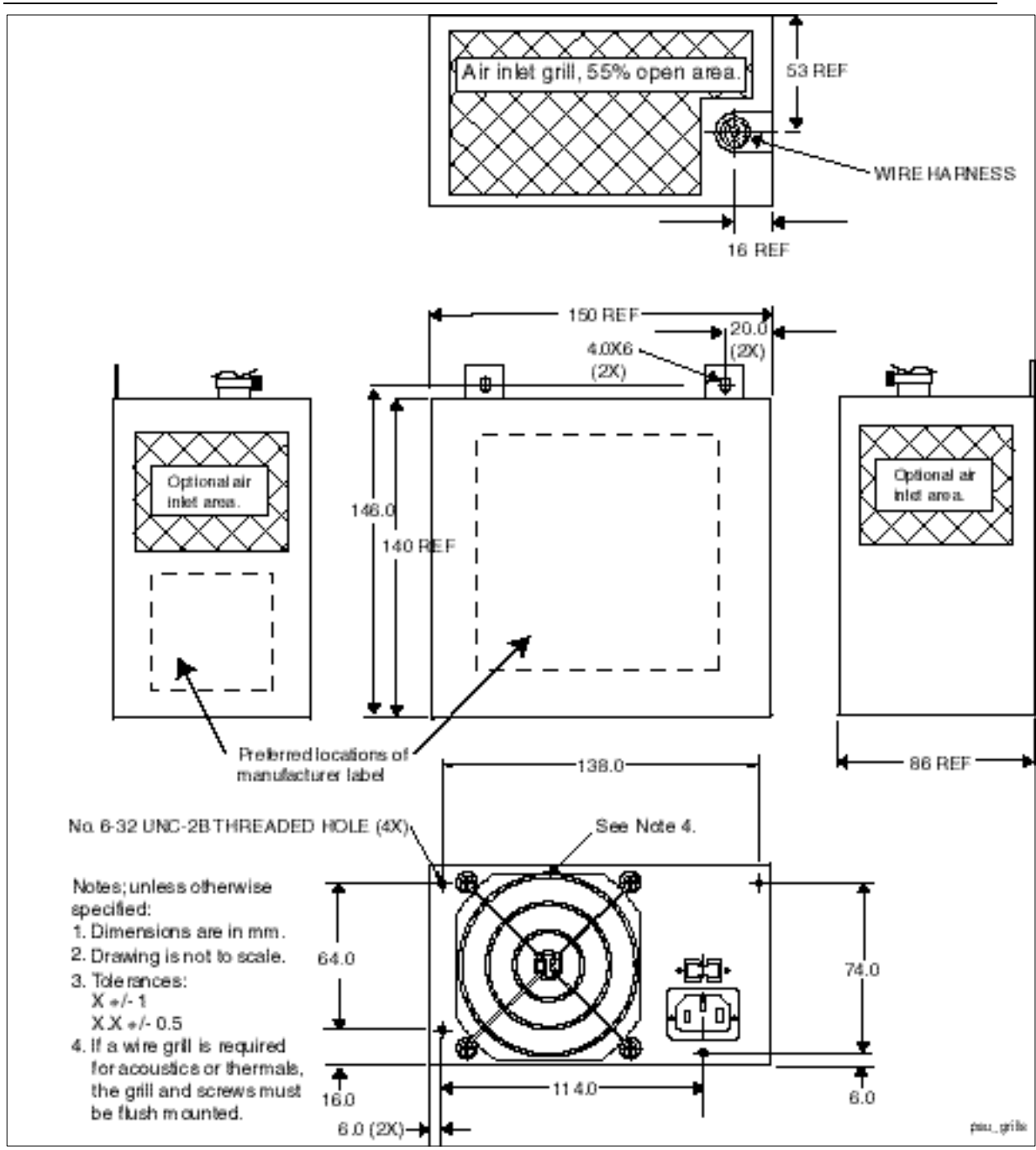

**Figure 4. Power Supply Dimensions for Chassis in Which the P/S Does Not Cool Processor**



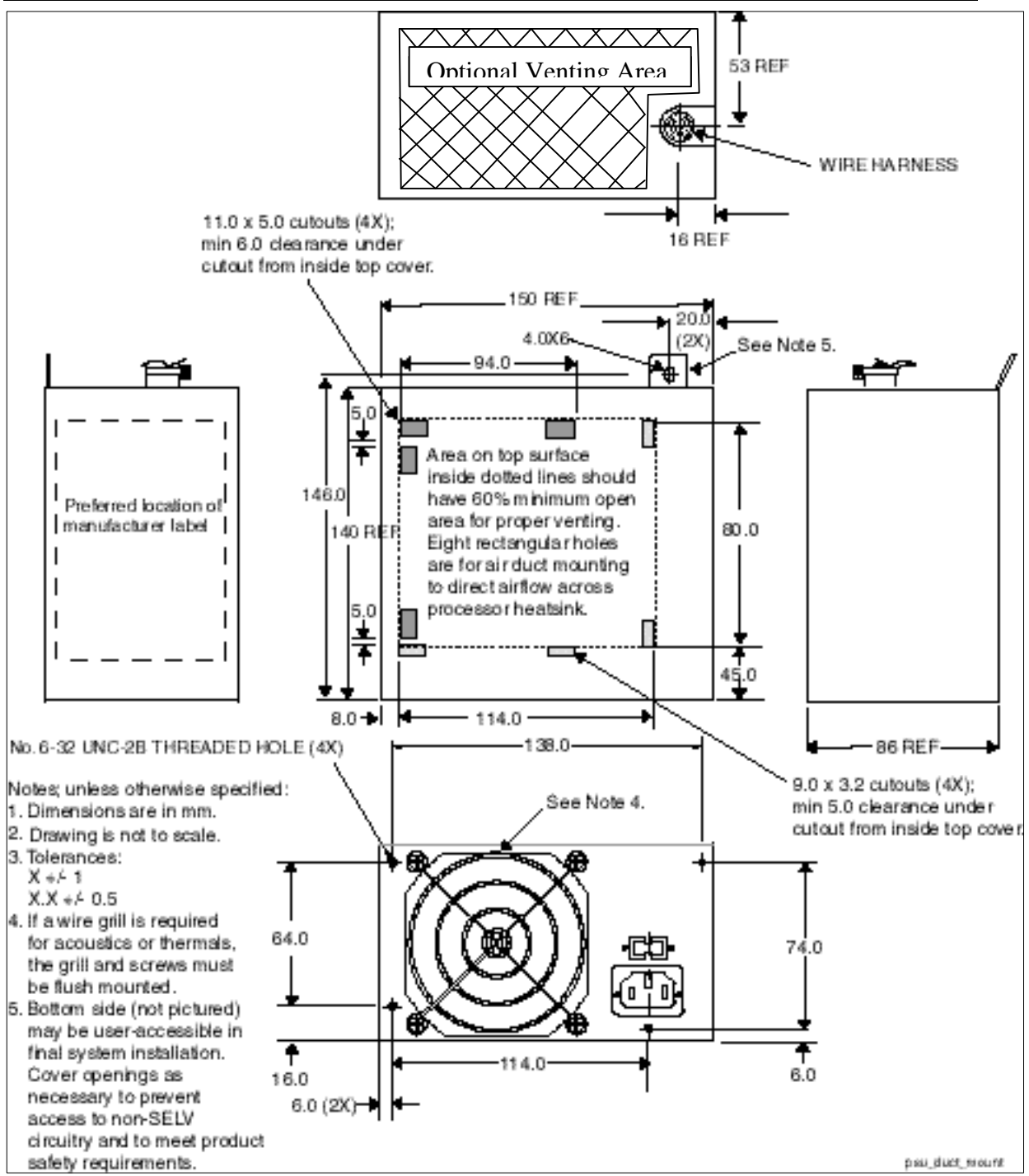

Figure 5. Power Supply Dimensions for Chassis in Which the P/S Cools the Processor

### 4.3. Airflow / Fan

The *ATX Specification* allows for numerous (and often confusing) possibilities for power supply fan location, direction, speed, and venting. The designer's choice of a power supply cooling solution depends in part on the targeted end-use system application(s). At a minimum, the power supply design must ensure its own reliable and safe operation.

Fan location/direction. In general, exhausting air from the system chassis enclosure via a power supply fan at the rear panel is the preferred, most common, and most widely applicable system-level airflow solution. Other solutions are permitted, however, and some system/chassis designers may choose to use other solutions to meet specific system cooling requirements.

Fan size/speed. An 80 mm or larger axial fan is typically needed to provide enough cooling airflow through an average ATX system. Exact CFM requirements vary by application and end-use environment, but 25-35 CFM is typical for the fan itself.

For consumer or other noise-sensitive applications, it is recommended that a thermally sensitive fan speed control circuit be used to balance system-level thermal and acoustic performance. The circuit typically senses the temperature of the secondary heatsink and/or incoming ambient air and adjusts the fan speed as necessary to keep power supply and system component temperatures within specification. Both the power supply and system designers should be aware of the dependencies of the power supply and system temperatures on the control circuit response curve and fan size and should specify them very carefully.

The power supply fan should be turned off when PS\_ON# is deasserted (high). In this state, any remaining active power supply circuitry must rely only on passive convection for cooling.

Venting. In general, more venting in a power supply case yields reduced airflow impedance and improved cooling performance. Intake and exhaust vents should be as large, open, and unobstructed as possible so as not to impede airflow or generate excessive acoustic noise. In particular, avoid placing objects within 0.5 inches of the intake or exhaust of the fan itself. A flush-mount wire fan grill can be used instead of a stamped metal vent for improved airflow and reduced acoustic noise.

There are three caveats to the venting guidelines above:

- Openings must be sufficiently designed to meet the safety requirements described in Section 8.
- Larger openings yield decreased EMI-shielding performance (see Section 6).
- Venting in inappropriate locations can detrimentally allow airflow to bypass those areas where it is needed.

The *ATX Specification* offers two options for venting between the power supply and the system interior:

- The venting shown in Figure 4 provides the most effective channeled airflow for the power supply itself, with little regard for directly cooling any system components. This venting method is nearly always used in conjunction with a fan that exhausts out the rear of the power supply.
- The venting shown in Figure 5 allows designers to more directly couple the power supply airflow to system components such as the processor or motherboard core, potentially cooling all critical components with a single fan. Both the power supply fan location and direction may vary in this case. The trade-off is usually one of reduced system cost versus narrower design applicability.

## 4.4. AC Connector

The AC input receptacle should be an IEC 320 type or equivalent. In lieu of a dedicated switch, the IEC 320 receptacle may be considered the mains disconnect.

## 4.5. DC Connectors

Figure 6 shows pinouts and profiles for typical ATX power supply DC harness connectors.

Listed or recognized component appliance wiring material (AVLV2), CN, rated min 85 °C, 300 VDC shall be used for all output wiring.

There are no specific requirements for output wire harness lengths, as these are largely a function of the intended end-use chassis, motherboard, and peripherals. Ideally, wires should be short to minimize electrical/airflow impedance and simplify manufacturing, yet they should be long enough to make all necessary connections without any wire tension (which can cause disconnections during shipping and handling). Recommended minimum harness lengths for general-use power supplies are 280 mm for the +12 V power connector and 250 mm for all other wire harnesses. Measurements are made from the exit port of the power supply case to the wire side of the first connector on the harness.

### NOTE

Details of the 2x3 “Optional Power Connector” mentioned in the ATX 2.03 Specification are omitted from this design guide until such time as the signals on that connector are more rigidly defined.

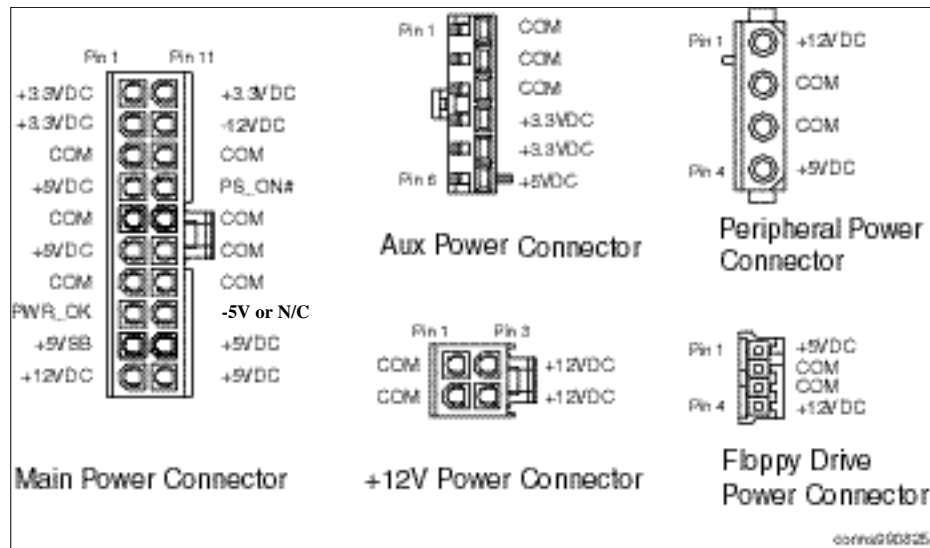

**Figure 6. ATX and ATX12V Power Supply Connectors**  
(Pin-side view, not to scale)

#### 4.5.1. ATX Main Power Connector

**Connector: MOLEX 39-01-2200 or equivalent**

(Mating motherboard connector is Molex 39-29-9202 or equivalent)

18 AWG is suggested for all wires except for the +3.3 V sense return wire, pin 11 (22 AWG). For 300 W configurations, 16 AWG is recommended for all +12 VDC, +5 VDC, +3.3 VDC, and COM.

Pin	Signal	Color	Pin	Signal	Color
1	+3.3VDC	Orange	11	+3.3VDC	Orange
2	+3.3VDC	Orange	[11]	[+3.3 V default sense]	[Brown]
3	COM	Black	12	-12VDC	Blue
4	+5VDC	Red	13	COM	Black
5	COM	Black	14	PS_ON#	Green
6	+5VDC	Red	15	COM	Black
7	COM	Black	16	COM	Black
8	PWR_OK	Gray	17	COM	Black
9	+5VSB	Purple	18	-5VDC	White
10	+12VDC	Yellow	19	+5VDC	Red
			20	+5VDC	Red

### 4.5.2. +12 V Power Connector (for ATX12V Configurations Only)

<b>Connector: MOLEX 39-01-2040 or equivalent</b> (Mating motherboard connector is Molex 39-29-9042 or equivalent)					
Pin	Signal	20 AWG Wire	Pin	Signal	20 AWG Wire
1	COM	Black	3	+12VDC	Yellow
2	COM	Black	4	+12VDC	Yellow

### 4.5.3. Auxiliary Power Connector for Configurations with +3.3 VDC Output > 18 A or +5 V Output > 24 A

<b>Connector: MOLEX 90331-0010 (keyed pin 6) or equivalent</b>		
Pin	Signal	16 AWG Wire
1	COM	Black
2	COM	Black
3	COM	Black
4	+3.3VDC	Orange
5	+3.3VDC	Orange
6	+5VDC	Red

### 4.5.4. Peripheral Connector(s)

<b>Connector: AMP 1-480424-0 or MOLEX 8981-04P or equivalent.</b>		
<b>Contacts: AMP 61314-1 or equivalent.</b>		
Pin	Signal	18 AWG Wire
1	+12VDC	Yellow
2	COM	Black
3	COM	Black
4	+5VDC	Red

### 4.5.5. Floppy Drive Connector

<b>Connector: AMP 171822-4 or equivalent</b>		
Pin	Signal	20 AWG Wire
1	+5VDC	Red
2	COM	Black
3	COM	Black
4	+12VDC	Yellow

## 5. Environmental

---

The following subsections define recommended environmental specifications and test parameters, based on the typical conditions to which an ATX and ATX12V power supply may be subjected during operation or shipment.

### 5.1. Temperature

Operating ambient	+10 °C to +50 °C (At full load, with a maximum temperature rate of change of 5 °C/10 minutes, but no more than 10 °C/hr.)
Nonoperating ambient	-40 °C to +70 °C (Maximum temperature rate of change of 20 °C/hr.)

### 5.2. Thermal Shock (Shipping)

Nonoperating	-40 °C to +70 °C 15 °C/min $\leq$ dT/dt $\leq$ 30 °C/min Tested for 50 cycles; Duration of exposure to temperature extremes for each half cycle shall be 30 minutes.
--------------	--

### 5.3. Humidity

Operating	To 85% relative humidity (noncondensing)
Nonoperating	To 95% relative humidity (noncondensing)

Note: 95% RH is achieved with a dry bulb temperature of 55 °C and a wet bulb temperature of 54 °C.

### 5.4. Altitude

Operating	To 10,000 ft
Nonoperating	To 50,000 ft

### 5.5. Mechanical Shock

Nonoperating	50 g, trapezoidal input; velocity change $\geq$ 170 in/s Three drops on each of six faces are applied to each sample.
--------------	--

## 5.6. Random Vibration

Nonoperating                      0.01 g<sup>2</sup>/Hz at 5 Hz, sloping to 0.02 g<sup>2</sup>/Hz at 20 Hz, and maintaining 0.02 g<sup>2</sup>/Hz from 20 Hz to 500 Hz. The area under the PSD curve is 3.13 gRMS. The duration shall be 10 minutes per axis for all three axes on all samples.

## 5.7. Acoustics

Acoustic requirements will be set by the final computer OEM system-level requirements.

## 6. Electromagnetic Compatibility

The following subsections outline sample product regulations requirements for a typical power supply. Actual requirements will depend on the design, product end use, target geography, and other variables. Consult your company's Product Safety and Regulations department for more details.

### 6.1. EMI

The power supply shall comply with CISPR 22, Class B, for both conducted and radiated emissions with a 4 dB margin. Tests shall be conducted using a shielded DC output cable to a shielded load. The load shall be adjusted as follows for three tests: No load on each output; 50% load on each output; and 100% load on each output. Tests will be performed at 100 VAC 50 Hz, 120 VAC 60 Hz, and 220 VAC 50 Hz power.

### 6.2. Input Line Current Harmonic Content and Line Flicker

For sales in EU (European Union) or Japan the power supply shall meet the requirements of EN61000-3-2 Class D and the Guidelines for the Suppression of Harmonics in Appliances and General Use Equipment Class D for harmonic line current content at full rated power. See Table 15 for the harmonic limits.

**Table 18: Harmonic Limits, Class D equipment**

Harmonic Order n	<i>Per: EN 61000-3-2</i>	<i>Per: JEIDA MITI</i>
	Maximum permissible Harmonic current at <u>230 VAC / 50 Hz</u> in Amps	Maximum permissible Harmonic current at <u>100VAC / 50 Hz</u> in Amps
	Odd harmonics	
3	2.3	5.29
5	1.14	2.622
7	0.77	1.771
9	0.4	0.92
11	0.33	0.759
13	0.21	0.483
$15 \leq n \leq 39$	$0.15 \times (15/n)$	$0.345 \times (15/n)$

### 6.3. Magnetic Leakage Fields

A PFC choke magnetic leakage field should not cause any interference with a high-resolution computer monitor placed next to or on top of the end-use chassis.



## 7. Reliability

---

### 7.1. Component Derating

The derating process promotes quality and high reliability. All electronic components should be designed with conservative device deratings for use in commercial and industrial environments.

### 7.2. Mean Time Between Failures (MTBF)

The MTBF of the power supply can be calculated with the Part-Stress Analysis method of MIL-HDBK-217F using the quality factors listed in MIL-HDBK-217F. A target calculated MTBF of the power supply is greater than 100,000 hours under the following conditions:

- Full-rated load
- 120 VAC input
- Ground benign
- 25 °C ambient

A target calculated MTBF of the power supply is greater than 30,000 hours under the following conditions:

- Full-rated load
- 120 VAC input
- Ground benign
- 50 °C ambient

## 8. Safety

---

The following subsections outline sample product regulations requirements for a typical power supply. Actual requirements will depend on the design, product end use, target geography, and other variables. Consult your company's Product Safety and Regulations department for more details.

### 8.1. North America

The power supply must be certified by an NRTL (Nationally Recognized Testing Laboratory) for use in the USA and Canada under the following conditions:

- The supply must be Recognized for use in Information Technology Equipment including Electrical Business Equipment per UL 1950 / CAN/CSA C22.2 No. 950-95, 3<sup>rd</sup> edition, without D3 deviations. The certification must include external enclosure testing for the AC receptacle side of the power supply (see Figures 4 and 5).
- The supply must have a full complement of tests conducted as part of the certification, such as input current, leakage current, hi-pot, temperature, energy discharge test, transformer output characterization test (open-circuit voltage, short-circuit current, and maximum VA output), and abnormal testing (to include stalled-fan tests and voltage-select-switch mismatch).
- The enclosure must meet fire enclosure mechanical test requirements per clauses 2.9.1 and 4.2 of the above-mentioned standard.

Production hi-pot testing must be included as a part of the certification and indicated as such in the certification report.

There must not be unusual or difficult conditions of acceptability such as mandatory additional cooling or power derating. The insulation system shall not have temperatures exceeding their rating when tested in the end product.

The certification mark shall be marked on each power supply.

The power supply must be evaluated for operator-accessible secondary outputs (reinforced insulation) that meet the requirements for SELV and do not exceed 240 VA under any condition of loading.

The proper polarity between the AC input receptacle and any printed wiring boards connections must be maintained (that is, brown=line, blue=neutral, green=earth/chassis).

Failure of any single component in the fan-speed control circuit shall not cause the internal component temperatures to exceed the abnormal fault condition temperatures per IEC 60950.

## 8.2. International

The vendor must provide a complete CB certificate and test report to IEC 950, 2<sup>nd</sup> edition + A1, A2, A3, and A4. The CB report must include ALL CB member country national deviations. CB report must include evaluation to EN60 950, + A1, A2, A3, A4 and EMKO-TSE (74-SEC) 207/94.

All evaluations and certifications must be for reinforced insulation between primary and secondary circuits.

## 8.3. Proscribed Materials

Cadmium should not be used in painting or plating.

No quaternary salt electrolytic capacitors shall be used.

Mercury shall not be used.

The use of CFCs or HFCs shall not be used in the design or manufacturing process.