

UL 310

ISBN 1-55989-887-9

Electrical Quick-Connect Terminals

Underwriters Laboratories Inc. (UL)
333 Pfingsten Road
Northbrook, IL 60062-2096

UL Standard for Safety for Electrical Quick-Connect Terminals, UL 310

Sixth Edition, Dated August 3, 1995

Revisions: This Standard contains revisions through and including May 23, 2001.

UL is in the process of converting its Standards for Safety to the Standard Generalized Markup Language (SGML), and implementing an SGML compliant document management and publishing system. SGML - an international standard (ISO 8879-1986) - is a descriptive markup language that describes a document's structure and purpose, rather than its physical appearance on a page. Significant benefits that will result from UL's use of SGML and these new systems include increased productivity, reduced turnaround times, and data and information consistency, reusability, shareability, and portability. However, the fonts, pagination, and general formatting of UL's new electronic publishing system differ from that of UL's previous publishing system. Consequently, when revision pages are issued for a Standard with the new publishing system, these differences may result in the printing of pages on which no requirements have been changed - these additional pages result from relocation of text due to repagination and reformatting of the Standard with the new publishing system.

Text that has been changed in any manner is marked with a vertical line in the margin. Changes in requirements are marked with a vertical line in the margin and are followed by an effective date note indicating the date of publication or the date on which the changed requirement becomes effective.

The new requirements are substantially in accordance with UL's Bulletin(s) on this subject dated December 18, 2000 . The bulletin(s) is now obsolete and may be discarded.

The revisions dated May 23, 2001 include a reprinted title page (page1) for this Standard.

As indicated on the title page (page 1), this UL Standard for Safety is an American National Standard. Attention is directed to the note on the title page of this Standard outlining the procedures to be followed to retain the approved text of this ANSI/UL Standard.

The master for this Standard at UL's Northbrook Office is the official document insofar as it relates to a UL service and the compliance of a product with respect to the requirements for that product and service, or if there are questions regarding the accuracy of this Standard.

UL's Standards for Safety are copyrighted by UL. Neither a printed copy of a Standard, nor the distribution diskette for a Standard-on-Diskette and the file for the Standard on the distribution diskette should be altered in any way. All of UL's Standards and all copyrights, ownerships, and rights regarding those Standards shall remain the sole and exclusive property of UL.

All rights reserved. No part of this publication may be reproduced, stored in a retrieval system, or transmitted in any form by any means, electronic, mechanical photocopying, recording, or otherwise without prior permission of UL.

Revisions of UL Standards for Safety are issued from time to time. A UL Standard for Safety is current only if it incorporates the most recently adopted revisions.

UL provides this Standard "as is" without warranty of any kind, either expressed or implied, including but not limited to, the implied warranties of merchantability or fitness for any purpose.

In no event will UL be liable for any special, incidental, consequential, indirect or similar damages, including loss of profits, lost savings, loss of data, or any other damages arising out of the use of or the inability to use this Standard, even if UL or an authorized UL representative has been advised of the possibility of such damage. In no event shall UL's liability for any damage ever exceed the price paid for this Standard, regardless of the form of the claim.

UL will attempt to answer support requests concerning electronic versions of its Standards. However, this support service is offered on a reasonable efforts basis only, and UL may not be able to resolve every support request. UL supports the electronic versions of its Standards only if they are used under the conditions and operating systems for which it is intended. UL's support policies may change from time-to-time without notification.

UL reserves the right to change the format, presentation, file types and formats, delivery methods and formats, and the like of both its printed and electronic Standards without prior notice.

Purchasers of the electronic versions of UL's Standards for Safety agree to defend, indemnify, and hold UL harmless from and against any loss, expense, liability, damage, claim, or judgement (including reasonable attorney's fees) resulting from any error or deviation introduced while purchaser is storing an electronic Standard on the purchaser's computer system.

If a single-user version electronic Standard was purchased, one copy of this Standard may be stored on the hard disk of a single personal computer, or on a single LAN file-server or the permanent storage device of a multiple-user computer in such a manner that this Standard may only be accessed by one user at a time and for which there is no possibility of multiple concurrent access.

If a multiple-user version electronic Standard was purchased, one copy of the Standard may be stored on a single LAN file-server, or on the permanent storage device of a multiple-user computer, or on an Intranet server. The number of concurrent users shall not exceed the number of users authorized.

Electronic Standards are intended for on-line use, such as for viewing the requirements of a Standard, conducting a word search, and the like. Only one copy of the Standard may be printed from each single-user version of an electronic Standard. Only one copy of the Standard may be printed for each authorized user of a multiple-user version of an electronic Standard. Because of differences in the computer/software/printer setup used by UL and those of electronic Standards purchasers, the printed copy obtained by a purchaser may not look exactly like the on-line screen view or the printed Standard.

An employee of an organization purchasing a UL Standard can make a copy of the page or pages being viewed for their own fair and/or practical internal use.

The requirements in this Standard are now in effect, except for those paragraphs, sections, tables, figures, and/or other elements of the Standard having future effective dates as indicated in the note following the affected item. The prior text for requirements that have been revised and that have a future effective date are located after the Standard, and are preceded by a "SUPERSEDED REQUIREMENTS" notice.

New product submittals made prior to a specified future effective date will be judged under all of the requirements in this Standard including those requirements with a specified future effective date, unless the applicant specifically requests that the product be judged under the current requirements. However, if the applicant elects this option, it should be noted that compliance with all the requirements in this Standard will be required as a condition of continued Listing, Recognition, and Follow-Up Services after the effective date, and understanding of this should be signified in writing.

This Standard consists of pages dated as shown in the following checklist:

Page	Date
1-3	May 23, 2001
4	January 15, 1999
5-6B	May 23, 2001
7-8	January 15, 1999
8A-8B	May 23, 2001
9	January 15, 1999
10-11	August 3, 1995
12	January 15, 1999
13-14	May 23, 2001
15	January 15, 1999
16-17	August 3, 1995
18	January 15, 1999
19-20	August 3, 1995
21-22B	January 15, 1999
23-24	August 3, 1995
25	January 15, 1999
26	August 3, 1995
27	January 15, 1999
28	October 24, 1995
A1-A2	August 3, 1995
B1-B2	August 3, 1995

No Text on This Page

AUGUST 3, 1995
(Title Page Reprinted: May 23, 2001)

1

UL 310

Standard for Electrical Quick-Connect Terminals

The First through Third editions were titled Quick-Connect Terminals.

First Edition – July, 1976
Second Edition – July, 1978
Third Edition – August, 1981
Fourth Edition – May, 1985
Fifth Edition – November, 1991

Sixth Edition

August 3, 1995

Approval as an American National Standard (ANSI) covers the numbered paragraphs on pages dated August 3, 1995, October 24, 1995, and January 13, 1997 . These pages should not be discarded when revised or additional pages are issued if it is desired to retain the ANSI approved text.

An effective date included as a note immediately following certain requirements is one established by Underwriters Laboratories Inc.

Approved as ANSI/UL 310-1980, August 29, 1980
Approved as ANSI/UL 310-1986, August 13, 1986
Approved as ANSI/UL 310-1996, September 11, 1996

Revisions of this Standard will be made by issuing revised or additional pages bearing their date of issue. A UL Standard is current only if it incorporates the most recently adopted revisions, all of which are itemized on the transmittal notice that accompanies the latest set of revised requirements.

ISBN 1-55989-887-9

COPYRIGHT © 1976, 2001 UNDERWRITERS LABORATORIES INC.

No Text on This Page

CONTENTS

FOREWORD	4
-----------------------	---

INTRODUCTION

1 Scope	5
2 Glossary	5
3 General	6
3.1 Units of measurement	6
3.2 Undated references	6

CONSTRUCTION

4 General	6
5 Materials	6A
5.1 Connectors and production tabs	6A
5.2 Test tab	7
6 Dimensions	7
6.2 Production tab	8
6.3 Test tab	12
7 Insulation	13
8 Marking	14
9 Installation Instructions	16

PERFORMANCE

10 General	16
11 Preparation of Samples	16
12 Crimp Pull-Out Test	19
13 Engagement-Disengagement Test	19
14 Temperature and Heat Cycling Tests	20
14.1 General	20
14.2 Temperature test	22A
14.3 Heat cycling	23
15 Dielectric Strength Tests	24
15.1 General	24
15.2 Insulation puncture test	24
15.3 Flashover (Type A)	26
15.4 Flashover (Type B – Tubular sleeve)	26
16 Secureness of Insulation Test	27
16.1 General	27
16.2 Terminals with insulation other than the tubular sleeve type	27
16.3 Terminals with insulation of the tubular sleeve type	27
17 Moisture-Absorption Test	28

Reserved for future use

APPENDIX B – MILLIVOLT DROP TEST

B1 GeneralB1
B2 Millivolt Drop TestB1

No Text on This Page

FOREWORD

A. This Standard contains basic requirements for products covered by Underwriters Laboratories Inc. (UL) under its Follow-Up Service for this category within the limitations given below and in the Scope section of this Standard. These requirements are based upon sound engineering principles, research, records of tests and field experience, and an appreciation of the problems of manufacture, installation, and use derived from consultation with and information obtained from manufacturers, users, inspection authorities, and others having specialized experience. They are subject to revision as further experience and investigation may show is necessary or desirable.

B. The observance of the requirements of this Standard by a manufacturer is one of the conditions of the continued coverage of the manufacturer's product.

C. A product which complies with the text of this Standard will not necessarily be judged to comply with the Standard if, when examined and tested, it is found to have other features which impair the level of safety contemplated by these requirements.

D. A product employing materials or having forms of construction which conflict with specific requirements of the Standard cannot be judged to comply with the Standard. A product employing materials or having forms of construction not addressed by this Standard may be examined and tested according to the intent of the requirements and, if found to meet the intent of this Standard, may be judged to comply with the Standard.

E. UL, in performing its functions in accordance with its objectives, does not assume or undertake to discharge any responsibility of the manufacturer or any other party. The opinions and findings of UL represent its professional judgment given with due consideration to the necessary limitations of practical operation and state of the art at the time the Standard is processed. UL shall not be responsible to anyone for the use of or reliance upon this Standard by anyone. UL shall not incur any obligation or liability for damages, including consequential damages, arising out of or in connection with the use, interpretation of, or reliance upon this Standard.

F. Many tests required by the Standards of UL are inherently hazardous and adequate safeguards for personnel and property shall be employed in conducting such tests.

INTRODUCTION

1 Scope

1.1 These requirements apply to 0.110-, 0.125-, 0.187-, 0.205-, and 0.250-inch (2.8-, 3.2-, 4.8-, 5.2-, and 6.3-mm) wide electrical quick-connect wiring terminations, both connectors and tabs, for use in electrical equipment that comply with the requirements for such equipment.

1.2 These requirements apply to terminals intended for use with one or two Nos. 22 – 10 AWG (0.32 – 5.3 mm²) copper conductors for internal wiring connections in electrical equipment and for the field termination of conductors to electrical equipment.

1.3 These requirements do not apply to terminals for use with aluminum conductors.

1.4 These requirements do not apply to multi-pole terminals. Multi-pole terminals are covered by the Standard for Attachment Plugs and Receptacles, UL 498.

1.5 A product that contains features, characteristics, components, materials, or systems new or different from those covered by the requirements in this standard, and that involves a risk of fire or of electric shock or injury to persons shall be evaluated using appropriate additional component and end-product requirements to maintain the level of safety as originally anticipated by the intent of this standard. A product whose features, characteristics, components, materials, or systems conflict with specific requirements or provisions of this standard does not comply with this standard. Revision of requirements shall be proposed and adopted in conformance with the methods employed for development, revision, and implementation of this standard.

1.5 revised May 23, 2001

2 Glossary

2.1 For the purpose of this standard the following definitions apply.

2.2 BURRE – An extraneous protrusion in the stock, not considered an integral functional part of the connector or tab.

2.3 CONNECTOR – A terminal that is pushed onto a tab.

2.4 C26000 ALLOY – A copper-zinc alloy consisting of approximately 70 percent copper and 30 percent zinc (cartridge brass) as specified by the Copper Development Association's Copper Development Alloy (CDA) Standards Handbook, Wrought Copper and Copper Alloy Mill Products, Part 2 – Alloy Data.

2.5 DETENT – A dimple (depression) or hole in a tab that acts to engage a raised portion on the connector providing a latching means for the mating parts.

2.6 PRODUCTION TAB – A terminal that is inserted in a connector, manufactured to specified tolerances, and intended to mate with a connector to establish a connection in an electrical circuit.

2.7 QUICK-CONNECT WIRING TERMINATION – An electrical connection consisting of a male tab and female connector that can be readily engaged or disengaged without the use of a tool.

2.8 REFERENCE POINT – A specially marked point on a connector or tab that is used when making electrical test measurements.

2.9 TERMINAL – An electrical connecting device consisting of either a connector or tab.

2.10 TEST TAB – A tab manufactured to specified tolerances to provide an accurate base for measurements for electrical, mechanical, and temperature-rise tests.

3 General

3.1 Units of measurement

3.1.1 Values stated without parentheses are the requirement. Values in parentheses are explanatory or approximate information.

3.1.1 revised May 23, 2001

3.1.2 All alternating-current electrical measurements are in root-mean-square (rms) units unless otherwise stated.

3.2 Undated references

3.2.1 Any undated reference to a code or standard appearing in the requirements of this standard shall be interpreted as referring to the latest edition of that code or standard.

CONSTRUCTION

4 General

4.1 A terminal shall be designed to provide a reliable electrical connection between wires or between wires and components in electrical equipment, when used in the intended manner. Additional requirements concerning certain features such as insulation added at the time of assembly in equipment, spacings between wiring terminations of opposite polarity and between wiring terminations and non-current-carrying metal parts and the support of wires adjacent to the wiring terminations shall be the subject of consideration by the standard covering the specific equipment involved.

4.2 A connector shall comply with Materials, Section 5; the dimensional requirements of 6.1; and the test requirements of Sections 10 – 16 when the connector is tested in conjunction with a test tab complying with 5.2 and 6.3.

4.3 A production tab shall comply with Materials, Section 5; the dimensional requirements of 6.2; and the test requirements of Sections 10 – 16.

5 Materials

5.1 Connectors and production tabs

5.1.1 A connector or a production tab shall be made of plain or plated copper alloy or of nickel or nickel alloy.

Exception: A connector or a production tab may be plated steel or unplated steel of a corrosion-resistant alloy if the connector or tab is intended for use in an appliance or equipment where such construction is permitted.

5.1.2 After shearing, a formed connector or a production tab provided on a continuous strip, and intended to be fed into a tool for crimping and separating from the strip, need not be plated on the edge of the connector or tab where it was attached to the strip.

No Text on This Page

5.2 Test tab

5.2.1 Test tabs used in the mechanical tests, Crimp Pull-Out Test, Section 12, and Engagement-Disengagement Test, Section 13, shall be made of unplated brass, identified as C26000 Alloy.

5.2.2 Test tabs for the Temperature and Heat Cycling Tests, Section 14, shall be made of tin-plated steel or corrosion resistant steel having a hardness of 68 ± 5 on the Rockwell 30T scale.

Exception: An unplated brass test tab of C26000 Alloy may be used with a connector intended for use only with production tabs of copper alloy.

5.2.3 The hardness of a brass test tab shall be 62 ± 7 on the Rockwell 30T scale.

6 Dimensions

6.1 A connector shall have the configuration illustrated in Figure 6.1 and the dimensions specified in Table 6.1.

Figure 6.1
Envelope configuration of connectors

Figure 6.1 revised January 15, 1999

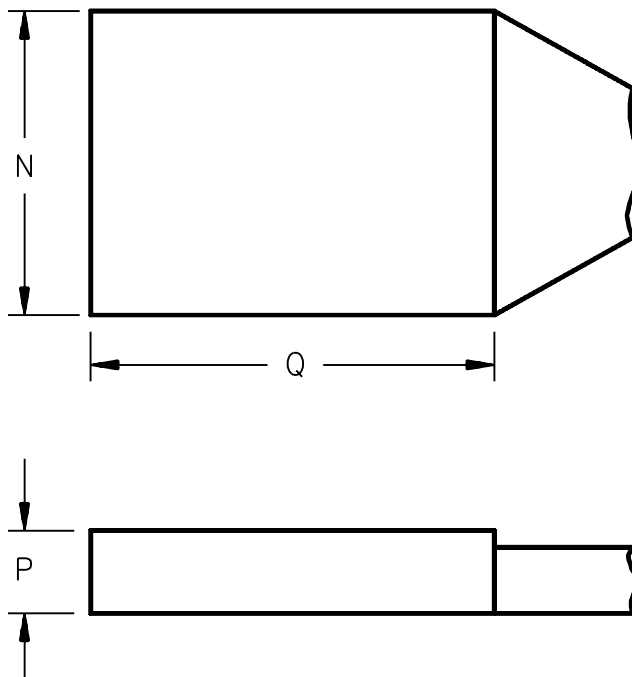

SB1281

Table 6.1
Dimensions of connectors

Dimensions, inch (mm)			
Tab width, nominal	N Maximum	P Maximum	Q Maximum
0.250 (6.3)	0.320 (8.13)	0.140 (3.56)	0.370 (9.40)
0.205 (5.2)	0.270 (6.86)	0.140 (3.56)	0.315 (8.00)
0.187 (4.8)	0.270 (6.86)	0.140 (3.56)	0.315 (8.00)
0.125 (3.2)	0.180 (4.57)	0.140 (3.56)	0.290 (7.37)
0.110 (2.8)	0.180 (4.57)	0.140 (3.56)	0.290 (7.37)

6.2 Production tab

6.2.1 A production tab shall have the configuration shown in Figures 6.2 – 6.4 and the dimensions specified in Table 6.2. Figure 6.3 shows dimensions of dimple detents and Figure 6.4 provides dimensions of hole detents.

Exception: A production tab may have alternate dimensions from those contained in Figures 6.2 – 6.4 and Table 6.2 if the tab is intended for use in an appliance or equipment that complies with the requirements for such appliance or equipment and is performance tested with a specific mating connector.

Figure 6.2
Dimensions of production and test tabs

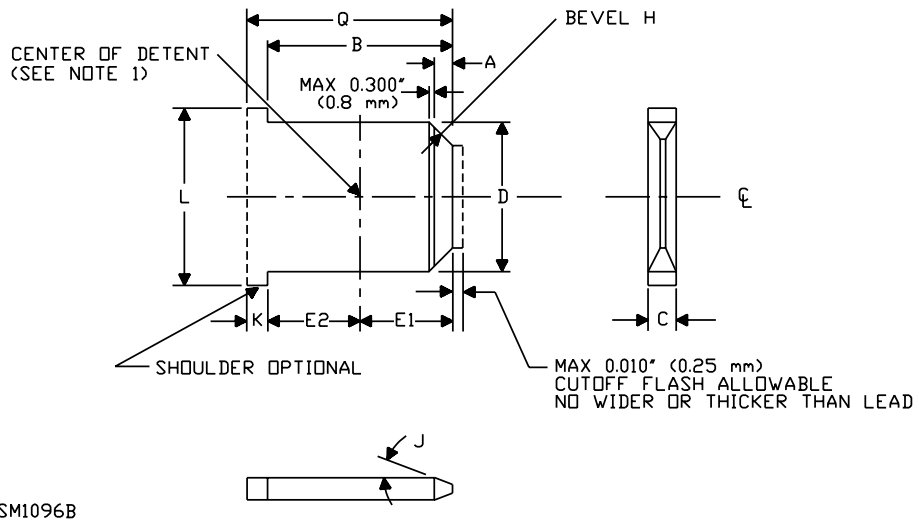
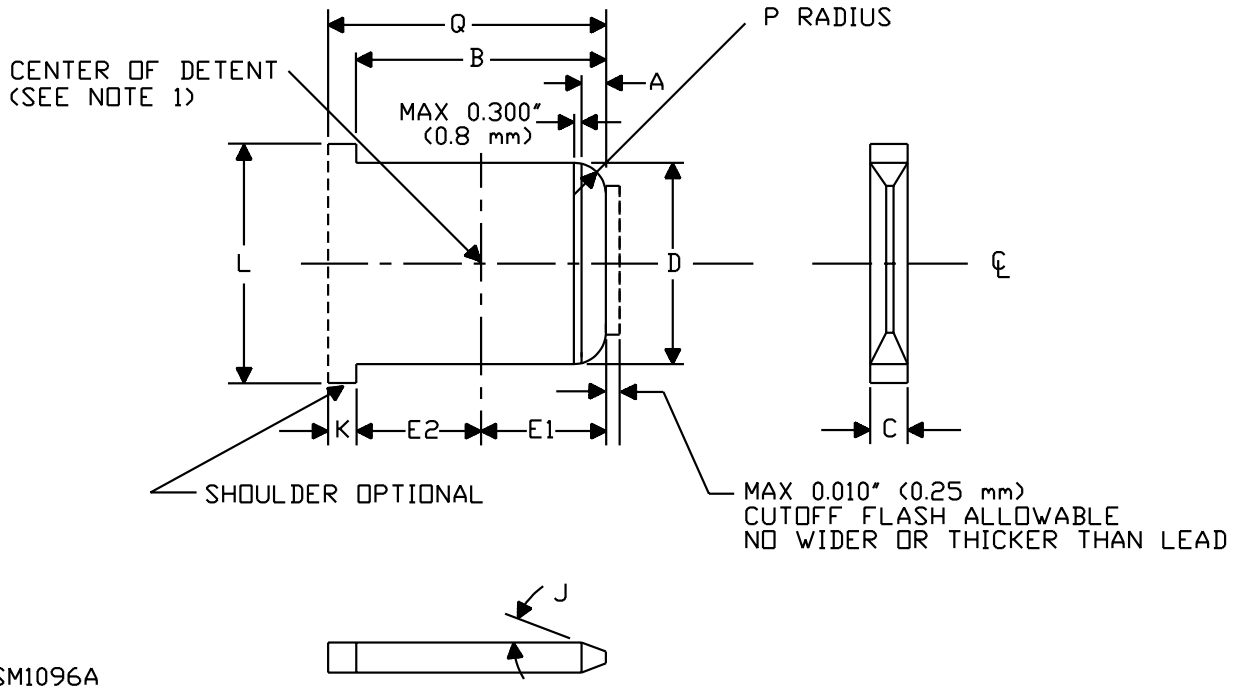

Note 1 – For detent and hole dimensions F, G, M, and N see Figures 6.3 and 6.4.

Note 2 – Bevel "H" need not be a straight line if it is within the confines shown, or it may be a radius of "P."

Note 3 – "Q" dimension is for tabs without shoulders.

Note 4 – "L" dimension not specified.

Figure 6.3
Dimensions of dimple detents

Figure 6.3 revised January 15, 1999

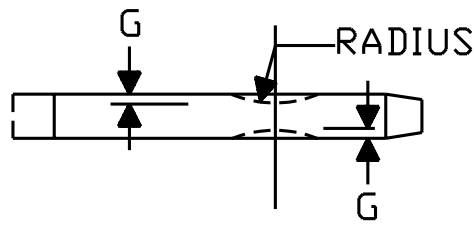
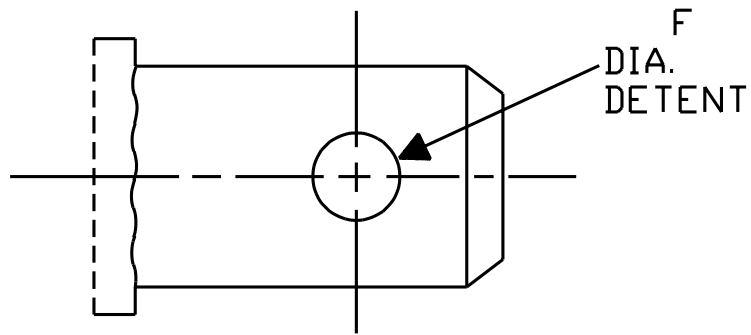

- OR -

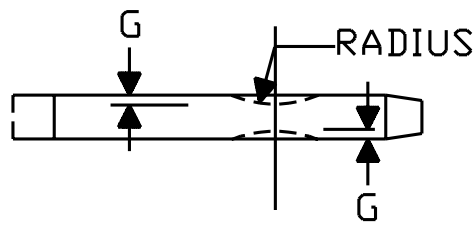
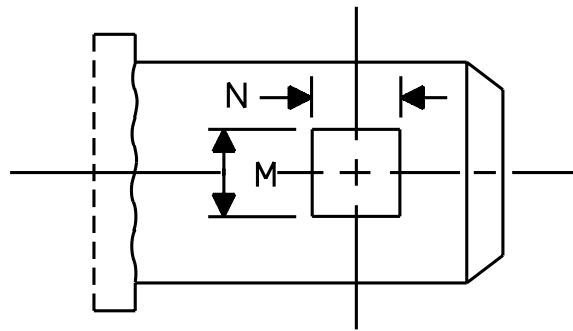

SM1095A

Figure 6.4
Dimensions of hole detents

Figure 6.4 revised January 15, 1999

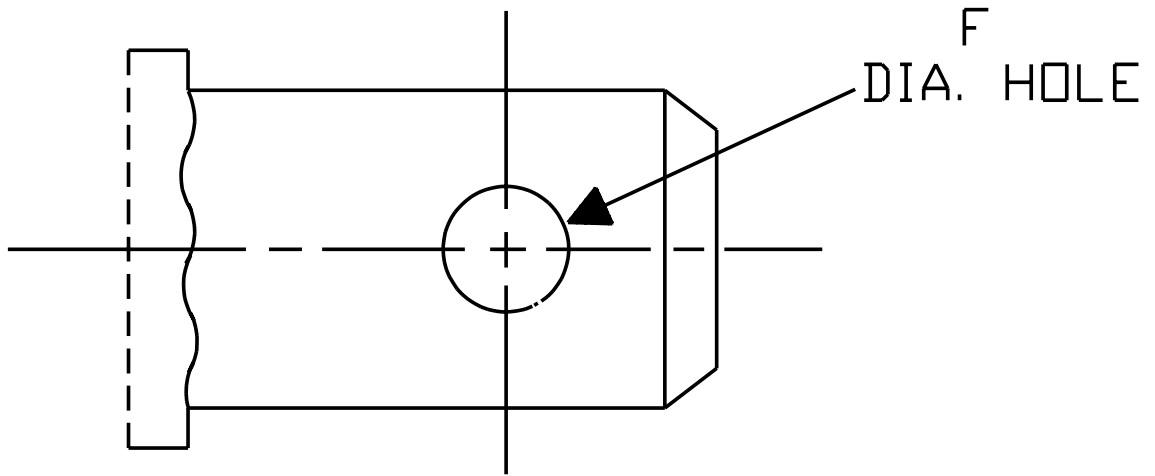

SM1094A

Table 6.2
Dimensions of production and test tabs in inches

Nominal size	A	B(min)	C	D	E1	E2	F	J	M	N	P	Q(min)
0.110 x 0.020 with dimple	0.024		0.021	0.114	0.071	0.221	0.051	12°	0.067	0.055	0.055	
	0.012	0.275	0.019	0.106	0.051	0.215	0.043	8°	0.055	0.039	0.012	0.319
0.110 x 0.020 with hole	0.024		0.021	0.114	0.071	0.221	0.051	12°			0.055	
	0.012	0.275	0.019	0.106	0.051	0.215	0.043	8°			0.012	0.319
0.110 x 0.032 with dimple	0.024		0.033	0.114	0.071	0.221	0.051	12°	0.067	0.055	0.055	
	0.012	0.275	0.030	0.106	0.051	0.215	0.043	8°	0.055	0.039	0.012	0.319
0.110 x 0.032 with hole	0.024		0.033	0.114	0.071	0.221	0.051	12°			0.055	
	0.012	0.275	0.030	0.106	0.051	0.215	0.043	8°			0.012	0.319
0.125 x 0.032 with dimple	0.025		0.033	0.128	0.070	0.221	0.051	12°	0.067	0.053	0.055	
	0.015	0.275	0.031	0.122	0.056	0.215	0.045	8°	0.057	0.043	0.015	0.320
0.125 x 0.032 with hole	0.025		0.033	0.128	0.070	0.221	0.051	12°			0.055	
	0.015	0.275	0.031	0.122	0.056	0.215	0.045	8°			0.015	0.320
0.125 x 0.020 with dimple	0.025		0.021	0.128	0.070	0.221	0.051	12°	0.067	0.053	0.055	
	0.015	0.275	0.019	0.122	0.056	0.215	0.045	8°	0.057	0.043	0.015	0.320
0.125 x 0.020 with hole	0.025		0.021	0.128	0.070	0.221	0.051	12°			0.055	
	0.015	0.275	0.019	0.122	0.056	0.215	0.045	8°			0.015	0.320
0.187 x 0.020 with dimple	0.035		0.021	0.190	0.110	0.153	0.060	12°	0.067	0.059	0.067	
	0.024	0.244	0.019	0.181	0.091	0.147	0.050	8°	0.055	0.047	0.024	0.287
0.187 x 0.020 with hole	0.035		0.021	0.193	0.134	0.128	0.060	12°			0.067	
	0.024	0.244	0.019	0.184	0.117	0.122	0.050	8°			0.024	0.287
0.187 x 0.032 with dimple	0.040		0.033	0.190	0.110	0.153	0.060	12°	0.067	0.059	0.071	
	0.027	0.244	0.030	0.181	0.091	0.147	0.050	8°	0.055	0.047	0.027	0.287
0.187 x 0.032 with hole	0.040		0.033	0.193	0.134	0.128	0.060	12°			0.071	
	0.024	0.244	0.030	0.184	0.117	0.122	0.050	8°			0.027	0.287
0.205 x 0.020 with dimple	0.040		0.021	0.210	0.110	0.153	0.075	12°	0.098	0.080	0.067	
	0.027	0.244	0.019	0.201	0.091	0.147	0.063	8°	0.086	0.070	0.024	0.287
0.205 x 0.020 with hole	0.040		0.021	0.210	0.134	0.128	0.075	12°			0.067	
	0.027	0.244	0.019	0.201	0.117	0.122	0.063	8°			0.024	0.287
0.205 x 0.032 with dimple	0.040		0.033	0.210	0.110	0.153	0.075	12°	0.098	0.080	0.071	
	0.027	0.244	0.030	0.201	0.091	0.147	0.063	8°	0.086	0.070	0.027	0.287
0.205 x 0.032 with hole	0.040		0.033	0.210	0.134	0.128	0.075	12°			0.071	
	0.027	0.244	0.030	0.201	0.117	0.122	0.063	8°			0.027	0.287
0.250 x 0.032 with dimple	0.040		0.033	0.253	0.161	0.163	0.080	12°	0.098	0.080	0.071	
	0.027	0.307	0.030	0.244	0.142	0.157	0.063	8°	0.086	0.070	0.027	0.350
0.250 x 0.032 with hole	0.040		0.033	0.253	0.186	0.137	0.080	12°			0.071	
	0.020	0.307	0.030	0.244	0.169	0.131	0.063	8°			0.027	0.350

NOTE – Included are dimensions for those nominal sizes corresponding with those found in the International Standard for Connecting Devices – Flat Quick-Connect Terminations for Electrical Copper Conductors – Safety Requirements, IEC 1210.

Table 6.3
Dimensions of metric production and test tabs in millimeters

Nominal size	A	B(min)	C	D	E1	E2	F	J	M	N	P	Q(min)
2.8 x 0.5 with dimple	0.6		0.54	2.90	1.8	5.61	1.3	12°	1.7	1.4	1.4	
	0.3	7.0	0.47	2.70	1.3	5.46	1.1	8°	1.4	1.0	0.3	8.1
2.8 x 0.5 with hole	0.6		0.54	2.90	1.8	5.61	1.3	12°			1.4	
	0.3	7.0	0.47	2.70	1.3	5.46	1.1	8°			0.3	8.1
2.8 x 0.8 with dimple	0.6		0.84	2.90	1.8	5.61	1.3	12°	1.7	1.4	1.4	
	0.3	7.0	0.77	2.70	1.3	5.46	1.1	8°	1.4	1.0	0.3	8.1
2.8 x 0.8 with hole	0.6		0.84	2.90	1.8	5.61	1.3	12°			1.4	
	0.3	7.0	0.77	2.70	1.3	5.46	1.1	8°			0.3	8.1
3.2 x 0.8 with dimple	0.6		0.84	3.25	1.8	5.61	1.3	12°	1.7	1.4	1.4	
	0.3	7.0	0.79	3.10	1.4	5.46	1.1	8°	1.4	1.1	0.3	8.1
3.2 x 0.8 with hole	0.6		0.84	3.25	1.8	5.61	1.3	12°			1.4	
	0.3	7.0	0.79	3.10	1.4	5.46	1.1	8°			0.3	8.1
3.2 x 0.5 with dimple	0.6		0.54	3.25	1.8	5.61	1.3	12°	1.7	1.4	1.4	
	0.3	7.0	0.48	3.10	1.4	5.46	1.1	8°	1.4	1.1	0.3	8.1
3.2 x 0.5 with hole	0.6		0.54	3.25	1.8	5.61	1.3	12°			1.4	
	0.3	7.0	0.48	3.10	1.4	5.46	1.1	8°			0.3	8.1
4.8 x 0.5 with dimple	0.9		0.54	4.80	2.8	3.89	1.5	12°	1.7	1.5	1.7	
	0.6	6.2	0.47	4.60	2.3	3.73	1.3	8°	1.4	1.2	0.6	7.3
4.8 x 0.5 with hole	0.9		0.54	4.90	3.4	3.25	1.5	12°			1.7	
	0.6	6.2	0.47	4.67	3.0	3.10	1.3	8°			0.6	7.3
4.8 x 0.8 with dimple	1.0		0.84	4.80	2.8	3.89	1.5	12°	1.7	1.5	1.8	
	0.7	6.2	0.77	4.60	2.3	3.73	1.3	8°	1.4	1.2	0.7	7.3
4.8 x 0.8 with hole	1.0		0.84	4.90	3.4	3.25	1.5	12°			1.8	
	0.6	6.2	0.77	4.67	3.0	3.10	1.3	8°			0.7	7.3
5.2 x 0.5 with dimple	1.0		0.54	5.30	2.8	3.89	1.9	12°	2.5	2.0	1.7	
	0.7	6.2	0.47	5.10	2.3	3.73	1.6	8°	2.2	1.8	0.6	7.3
5.2 x 0.5 with hole	1.0		0.54	5.30	3.4	3.25	1.9	12°			1.7	
	0.7	6.2	0.47	5.10	3.0	3.10	1.6	8°			0.6	7.3
5.2 x 0.8 with dimple	1.0		0.84	5.30	2.8	3.89	1.9	12°	2.5	2.0	1.8	
	0.7	6.2	0.77	5.10	2.3	3.73	1.6	8°	2.2	1.8	0.7	7.3
5.2 x 0.8 with hole	1.0		0.84	5.30	3.4	3.25	1.9	12°			1.8	
	0.7	6.2	0.77	5.10	3.0	3.10	1.6	8°			0.7	7.3
6.3 x 0.8 with dimple	1.0		0.84	6.40	4.1	4.14	2.0	12°	2.5	2.0	1.8	
	0.7	7.8	0.77	6.20	3.6	3.99	1.6	8°	2.2	1.8	0.7	8.9
6.3 x 0.8 with hole	1.0		0.84	6.40	4.7	3.48	2.0	12°			1.8	
	0.5	7.8	0.77	6.20	4.3	3.33	1.6	8°			0.7	8.9

NOTE – Included are dimensions for those nominal sizes corresponding with those found in the International Standard for Connecting Devices – Flat Quick-Connect Terminations for Electrical Copper Conductors – Safety Requirements, IEC 1210.

6.2.2 All portions of a production tab shall be flat, its surfaces not deviating more than 0.010 inch/inch (0.010 mm/mm) and free from objectionable burrs, no greater than 10 percent of tab thickness, or raised plateaus.

Exception: In an area 0.050 inch (1.3 mm) surrounding the detent, a raised plateau over the stock thickness of 0.001 inch (0.03 mm) per side is acceptable.

6.2.3 For an optional shoulder, the minimum dimension shall be 0.045 inch (1.14 mm). See dimension "K" of Figure 6.2. There shall not be any obstructions within 0.045 inch (1.14 mm) of the "K" dimension end of the area defined by dimension "B."

6.2.4 If the detent is located with reference to a shoulder, it shall be located on the tab in accordance with dimension "E2." If no shoulder is used, the detent shall be located on the tab in accordance with dimension "E1." The center of a hole or detent shall be within 0.003 inch (0.08 mm) of the centerline of the tab. The depth of a dimple, dimension "G" on Figure 6.3, shall not be less than 0.003 inch (0.08 mm).

6.2.5 Bevel "H" shall be approximately 45°. See note 2 to Figure 6.2.

6.2.6 Dimensional measurements shall not include plating, burrs, or flatness tolerance.

6.3 Test tab

6.3.1 Single-ended test tabs shall have the configuration shown in Figures 6.2 – 6.4 and the dimensions specified in Table 6.2. The "C" dimension tolerance shall be ± 0.0003 inch (0.008 mm) for brass and ± 0.0005 inch (0.013 mm) for steel, and raised plateaus around the detent shall be limited to a total of 0.001 inch (0.03 mm) for both sides.

6.3.1 revised January 15, 1999

6.3.2 Double-ended test tabs for the temperature and heat cycling tests shall have the configuration shown in Figure 6.5.

Figure 6.5
Double-ended test tab for temperature rise and heat cycling tests

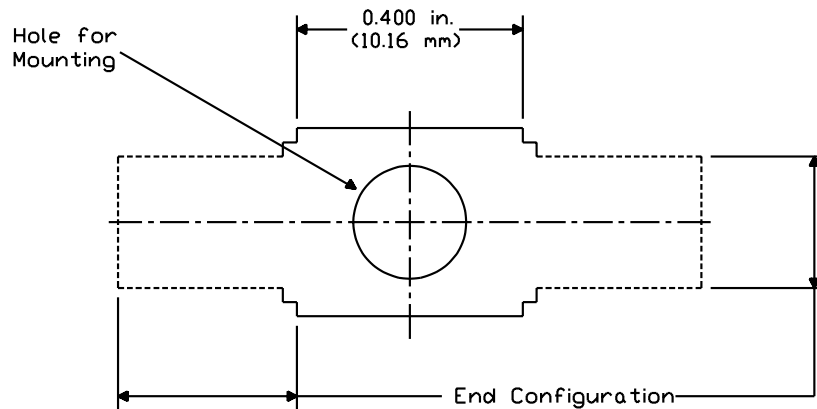

SM1092

(See Figures 6.2 – 6.4 and Tables 6.2 or 6.3)

With the permission of the Canadian Standards Association (CSA), this material is reproduced from C22.2 No. 153-M1981 (R1992) – Quick Connect Terminals, which is copyrighted by CSA.

7 Insulation

7.1 Insulation provided as a part of a terminal shall be porcelain, cold-molded or phenolic composition, or other material rated for the purpose.

7.2 Insulation provided as a part of a terminal shall be considered on the basis that it is rated for operation at one of the temperatures specified in Table 7.1.

Table 7.1
Maximum operating temperature for insulating material

Table 7.1 revised January 15, 1999

Material	Temperature	
	°C	°F
Thermoplastic ^a	60	140
	75	167
	90	194
	105	221
	150	302
Phenolic ^b	150	302
Urea ^c	100	212
Melamine ^d	130	266
Melamine ^e	150	302

^a Temperature rating is the Relative Thermal Index (RTI) as rated by the insulation manufacturer or a rating as assigned by the connector manufacturer.

Table 7.1 Continued on Next Page

Table 7.1 Continued

Material	Temperature	
	°C	°F
^b Composition may be filled or unfilled. ^c Unless the compound has been found by test to be acceptable for use at a higher temperature. ^d Composition with a specific gravity less than 1.55. ^e Composition with a specific gravity 1.55 or more. The compound may have cellulosic filler material.		

7.2.1 The insulating material is able to have a flammability classification as determined by tests described in the Standard for Tests for Flammability of Plastic Materials for Parts in Devices and Appliances, UL 94. See 7.2.2.

7.2.1 added May 23, 2001

7.2.2 In addition to the required markings, the manufacturer is able to mark the flammability classification of the insulating material on the connector, smallest unit container, or on an information sheet placed in the smallest unit container. See 7.2.1.

7.2.2 added May 23, 2001

7.3 Insulation consisting of natural or Styrene Butadiene Rubber (SBR) or a thermoplastic material shall be subjected to an appropriate investigation to determine if it is acceptable for the purpose.

7.4 Porcelain or cold-molded composition used as electrical insulation shall additionally comply with the Moisture Absorption Test, Section 17.

7.4 revised January 13, 1997

8 Marking

8.1 Each terminal shall be marked with the manufacturer's name, trademark, or other descriptive marking by which the organization responsible for the product may be identified.

8.2 The smallest container, reel, or packaging carton containing terminals shall be legibly and permanently marked with:

- a) The manufacturer's name, trade name, or trademark;

Exception: The manufacturer's identification may be in a traceable code if identified by a brand or a trademark owned by a private labeler.

- b) A distinctive catalog, model number, or the equivalent;

- c) The wire size or sizes for single-wire application and the minimum and maximum AWG wire sizes for two-wire application for which the terminal has been found acceptable;

- d) A statement referring to the manufacturer's installation instructions if such separate instructions are needed;
- e) A statement indicating if the terminals are acceptable for internal wiring of electrical equipment, for field termination of conductors, or for both;
- f) A statement informing the end-use manufacturer that if the terminals are to be used for field termination of conductors to electrical equipment, such equipment is to be provided with strain relief, and is to be marked with instructions for effecting the strain relief and providing reference to the specific terminals to be used; and
- g) A statement indicating that the terminals are suitable for termination of copper wire only – for example, "copper wire only" or equivalent wording.

Exception: For terminals not capable of terminating a wire, such as printed circuit mounted items, the container, reel, or packaging carton need not be marked that the terminals are suitable for termination of copper wire only.

8.2 revised January 15, 1999

8.3 The voltage rating for which an insulated terminal has been found acceptable shall be marked on the terminal or the smallest unit container. The marked voltage rating, shall be: "300 V maximum," "600 V maximum," or "600 V maximum building wiring; 1000 V maximum signs or lighting fixtures (luminaires)" or equivalent. The word "luminaires" is optional.

8.4 The maximum operating temperature for which an insulated terminal is rated, in accordance with Table 7.1, shall be marked on the terminal.

8.5 If a manufacturer produces terminals at more than one factory, each terminal or the smallest packaging carton shall have a distinctive marking – which may be in code – by which it may be identified as the product of a particular factory.

8.6 If a terminal intended for field termination of conductors is tested with stranded wire as specified in the Exception to 11.4, the wire size for which the terminal has been found acceptable – see 8.2 – shall be followed by "STRANDED" or "STR."

8.7 The method of rearrangement or adjustment of a terminal to adapt it to various sizes of wire shall be indicated clearly, if it is not obvious, by size markings or other instructions appearing on the terminal or the appropriate packaging unit noted in 8.2.

8.8 The minimum and maximum wire strip length marking for an insulated terminal may be specified as a single (nominal) value as specified in 11.8. The marking shall appear:

- a) On or in the smallest unit container in which the terminal is packed;
- b) On the terminal; or
- c) On an insulating cover.

Exception No. 1: The marking shall be optional if a terminal is provided with an open end opposite the wire insertion end through which the end of the wire is visible after it is connected.

Exception No. 2: The minimum strip length marking shall be optional if a terminal is provided with an inspection hole opposite the wire insertion end through which the end of the wire is visible after it is connected.

9 Installation Instructions

9.1 Installation instructions shall be provided and shall include the following features as applicable to the procedure for assembly of a terminal to one or two wires:

- a) For a terminal intended to be assembled to a wire or wires by means of a specific type of tool, the tool designation or the designation of a removable tool part such as a pressing die shall be marked on or in the container in which the terminal is packed and shall be identified by the catalog designation, color coding, die index number, or other equivalent means;
- b) Instructions for preparation of the wires, such as twisting strands together before assembly, shall appear on or in the container in which the terminal is packed;
- c) The minimum and maximum wire strip length marking for an insulated terminal shall appear as specified in 8.8.

PERFORMANCE

10 General

10.1 A connector and a production tab shall perform acceptably when subjected to the Crimp Pull-Out Test, Section 12.

10.2 A connector shall perform acceptably when subjected to the Engagement-Disengagement Test, Section 13 and the Temperature and Heat Cycling Tests, Section 14.

10.3 Acceptable performance of a connector shall be based on the use of test tabs. A double-ended test tab shall be used for temperature and heat cycling tests. A single-ended test tab shall be used for all mechanical tests in this standard.

10.4 Insulated terminals shall additionally perform acceptably when subjected to the Dielectric Strength Tests, Section 15, and Secureness of Insulation Test, Section 16.

10.5 The insulation of a terminal shall not crack or break when the terminal is assembled as intended on an insulated wire or wires.

10.6 A terminal that is intended for both field terminations of conductors and internal wiring connections shall be tested using the wires specified in 11.3 and 11.4.

10.7 Values of voltage and current are rms values, unless otherwise stated.

11 Preparation of Samples

11.1 To determine if a terminal complies with the requirements in 10.1, representative samples of the terminal shall be assembled to lengths of wire or wires of the size or sizes and in the manner specified by the manufacturer, see 8.7.

11.2 For the crimp pull-out and engagement-disengagement tests, ten new connectors and ten new single-ended test tabs shall be used for each test. For the temperature rise and heat cycling tests, ten new connectors and five new double-ended test tabs shall be used. Additional connectors and tabs are necessary to complete the test circuit illustrated in Figure 14.1.

11.3 Tin-plated wire with stranding, as specified in Table 11.1 under the heading "internal wiring" shall be used for tests on a terminal intended only for internal wiring connections. The wire shall have thermoplastic insulation not greater than 1/32 inch (0.8 mm) thick.

Table 11.1
Number of strands for test wire

AWG (mm ²)	Number of strands	
	Internal wiring ^a	Field terminations ^b
22 (0.32)	7	7
20 (0.52)	10	10
18 (0.82)	16	16
16 (1.3)	26	26
14 (2.1)	41	7
12 (3.3)	65	7
10 (5.3)	105	7

^a See 11.3.
^b See Exception to 11.4.

11.4 A terminal intended for field termination of conductors shall be tested with insulated solid wire. See Table 11.2 for insulation type.

Exception: Stranded conductors with stranding as specified in Table 11.1 and Table 11.2 may be used if marking in accordance with 8.6 is provided.

Table 11.2
Test wire stranding and insulation type

Wire size, AWG (mm ²)	Solid	Stranded
14 – 10 (2.1 – 5.3)	Soft annealed-untinned type XHHW, USE, or THW	Concentric or compressed Class B stranding, soft annealed-untinned, Type XHHW, USE, or THW
18 – 16 (0.82 – 1.3)	Untinned, thermoplastic insulation not greater than 1/32 inch (0.8 mm) thick	Untinned, thermoplastic insulation not greater than 1/32 inch (0.8 mm) thick
22 – 20 (0.32 – 0.52)	Tinned or untinned, thermoplastic insulation	Tinned or untinned, thermoplastic insulation

11.5 The wire shall be stripped with care and twisted to its original shape before it is assembled to the terminal.

11.5 revised January 15, 1999

11.6 If a specific type of tool is necessary to obtain a proper installation, it shall be used in assembling the terminal to the wire or wires. If a terminal is designed to be assembled to a wire or wires by means of more than one type of tool, the terminal shall perform acceptably in the tests after any intended tool is used in the assembly operation.

11.7 With reference to 11.6, in selecting tools for assembly of a terminal to a conductor, the following features are to be considered:

- a) Profile, width, and depth of the terminal;
- b) Material of the terminal body;
- c) Crimping die geometry;
- d) The number of crimps; and
- e) Similarity of crimp forces.

11.8 For an insulated terminal marked with a nominal strip length in accordance with 8.8, the dielectric strength tests shall be conducted with wires stripped to the maximum tolerance specified in Table 11.3.

Table 11.3
Strip-length tolerances for wires

AWG	Wire size,		Tolerance,	
		(mm ²)	inch	(mm)
22 – 14		(0.32 – 2.1)	± 1/32	(0.80)
12 – 10		(3.3 – 5.3)	± 3/64	(1.2)

11.9 For an insulated terminal marked with a maximum wire-strip length and a minimum wire-strip length in accordance with 8.8, the dielectric strength tests shall be conducted with the wires stripped to the maximum length specified by the manufacturer.

12 Crimp Pull-Out Test

12.1 A connector or a production tab, when subjected to a force as specified in Table 12.1, shall not separate from the wire or wires to which it is assembled.

Table 12.1
Forces for crimp pull-out test

AWG	Wire size,		Minimum force,	
		(mm ²)	pounds	(N)
22		(0.32)	8	(36)
20		(0.52)	13	(58)
18		(0.82)	20	(89)
16		(1.3)	30	(133)
14		(2.1)	50	(223)
12		(3.3)	70	(311)
10		(5.3)	80	(356)

12.2 A connector or a production tab intended for use with wires of more than one size or a range of sizes shall be subjected to the test specified in 12.1 for each combination of connector or tab with a wire of each size or range of sizes. A connector designed for use with two simultaneously crimped conductors shall be tested with the conductor combination constituting the minimum circular cross-sectional area (CMA) and the conductor combination constituting the maximum circular cross-sectional area. If the connector or tab has a conductor insulation support, it shall be first rendered mechanically inactive for this test.

12.3 If a connector or a production tab is intended to secure two wires simultaneously, the assembly shall be suspended from the wire of the largest size in each sample, and the specified force shall be applied to the other wire. The value of the force shall be selected according to the size of the wire to which it is applied.

12.4 The force shall be applied gradually by means of a tensile testing machine. The head of the tensile testing machine shall be adjusted to travel at a speed of 1 inch/min. (25.4 mm/min.) until the specified minimum required force is obtained. The test sample shall then be held at the minimum required force for one minute.

13 Engagement-Disengagement Test

13.1 The forces required to engage and disengage a connector shall be in accordance with Table 13.1 for the number of insertions and withdrawals indicated.

Table 13.1
Insertion and withdrawal forces for engagement-disengagement test

Tab size, inch (mm)	Force, pounds (N)					
	First insertion, maximum individual	First withdrawal			Sixth withdrawal	
		Maximum	Minimum		Minimum	
			Average	Individual	Average	Individual
Test tab and unplated connector						
0.250 (6.3)	18 (80)	18 (80)	6 (27)	4 (18)	5 (22)	4 (18)
0.205 (5.2) and 0.187 (4.8)	15 (67)	20 (89)	5 (22)	3 (13)	3 (13)	2 (9)
0.125 (3.2) and 0.110 (2.8)	12 (53)	14 (62)	3 (13)	2 (9)	2 (9)	1 (4)
Test tab and tin-plated connector						
0.250 (6.3)	17 (76)	17 (76)	5 (22)	3 (13)	4 (18)	3 (13)
0.205 (5.2) and 0.187 (4.8)	15 (67)	20 (89)	5 (22)	3 (13)	3 (13)	2 (9)
0.125 (3.2) and 0.110 (2.8)	12 (53)	14 (62)	3 (13)	2 (9)	2 (9)	1 (4)

13.2 The force shall be measured with a testing device capable of holding the reading, and providing accurate alignment with slow and steady engagement and disengagement of the connector and test tab.

14 Temperature and Heat Cycling Tests

14.1 General

14.1.1 A connector designed for wire of only one size shall be tested with wire of that size.

14.1.2 A connector designed for wire with a range of sizes shall be tested with wires of both the maximum and minimum sizes in the range. A connector designed for use with two stranded conductors shall be tested with both the minimum and maximum wire sizes.

14.1.3 New connectors shall be crimped in the intended manner on both ends of 6-1/2 inch (165 mm) lengths of tin-plated copper wire of the size and type specified in 11.3, 11.4, or Exception to 11.4, as applicable. The method of preparation shall be as described in 11.6 – 11.9. The assembly shall be arranged and connected as illustrated in Figure 14.1 and Figure 14.2. The wire size for the power-supply leads and circuit-continuation wire shall be the same as that specified for the test.

Figure 14.1
Connection and arrangement for temperature and heat cycling tests

Figure 14.1 revised January 15, 1999

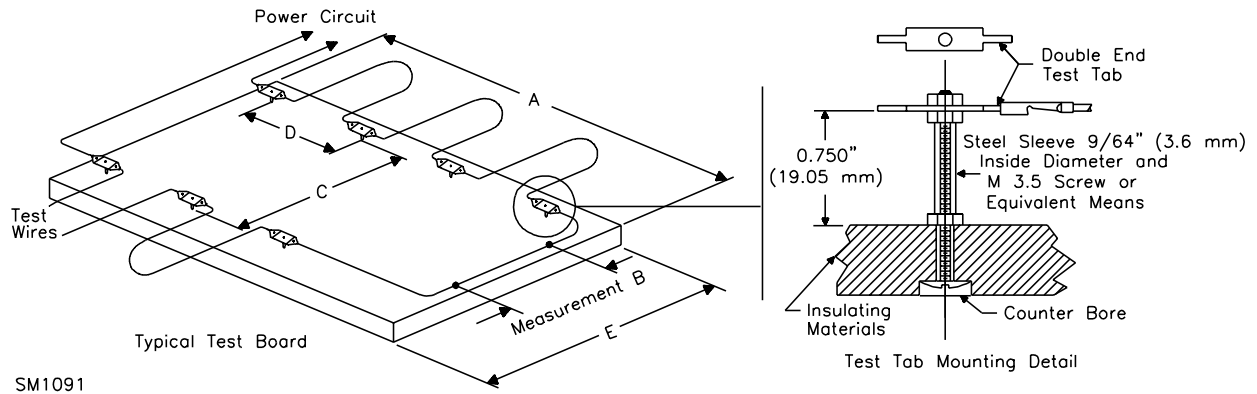

SM1091

Dimension	N.T.S	
	in	mm
A	16	400
B	12	300
C	12	300
D	4	100
E	14	350

With the permission of the Canadian Standards Association (CSA), this material is reproduced from C22.2 No. 153-M1981 (R1992) – Quick Connect Terminals, which is copyrighted by CSA.

Figure 14.2
Thermocouple location on connectors

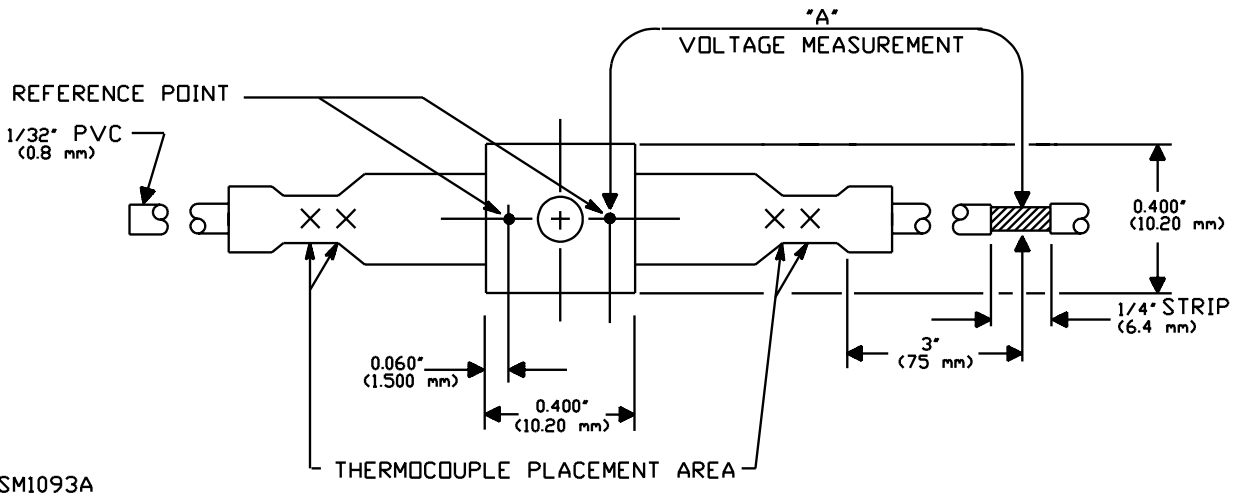

14.1.4 The tests described in 14.2.1 and 14.3.1 – 14.3.2 shall be conducted in a location where the air flow does not exceed 25 ft/min (0.12 m/s) and under the conditions described in 14.1.5 – 14.1.7.

14.1.5 The test shall be conducted at an ambient temperature of $25 \pm 5^\circ\text{C}$ ($77 \pm 9^\circ\text{F}$). The temperature rises specified in 14.2.1 and 14.3.1 shall be the observed temperatures of the connector minus the observed ambient temperature.

14.1.6 Any 60 Hz voltage may be used that will result in an essentially sinusoidal current of the specified value flowing through the connector.

14.1.7 The temperature shall be measured with thermocouples consisting of No. 30 AWG iron and constantan wires. The thermocouples and related instruments shall be calibrated in accordance with good laboratory practice. Each thermocouple shall make good contact with the surface being tested and shall not be relocated during the tests. A temperature shall be considered to be stable if three successive readings taken at intervals of 5 minutes indicate no further rise above the ambient temperature. A terminal shall not be acceptable if any one of the measured connector temperatures show a rise of more than those specified in 14.2 and 14.3.

14.2 Temperature test

14.2.1 The temperature rise of a connector shall not exceed 30°C (54°F) when the connector is continuously conducting the current specified in Table 14.1 or Table 14.2, as applicable.

No Text on This Page

Table 14.1
Test current for temperature and heat cycling tests for connectors intended for internal wiring only

Wire size,		Test current, amperes			
		Temperature		Heat cycling	
AWG	(mm ²)	0.110 inch (2.8 mm) and 0.125 inch (3.2 mm) terminals	All others	0.110 inch (2.8 mm) and 0.125 inch (3.2 mm) terminals	All others
22	(0.32)	2	3	4	6
20	(0.52)	3	4	6	8
18	(0.82)	4	7	8	14
16	(1.3)	5	10	10	20
14	(2.1)		15		30
12	(3.3)		20		40
10	(5.3)		24		48

Table 14.2
Test current for connectors intended for field termination of conductors

Wire size,		Test current, amperes	
		Continuous operation	Heat cycling
AWG	(mm ²)		
22	(0.32)	3	6
20	(0.52)	5	10
18	(0.82)	7	14
16	(1.3)	10	20
14	(2.1)	15	30
12	(3.3)	20	40
10	(5.3)	30	60

14.3 Heat cycling

14.3.1 After operation as described in 14.3.2, the temperature rise of a connector during the 500th cycle shall not be more than 15°C (27°F) higher than the temperature rise during the 24th cycle, and neither rise shall be more than 85°C (153°F).

14.3.2 After the continuous operation described in 14.2.1, the same samples shall be subjected to a 500 cycle test with a current as specified in Table 14.1 or Table 14.2, as applicable. Each cycle shall consist of full current for 45 minutes, followed by a 15 minute period during which no current flows. The full current portion of the cycle, during which temperature measurements are made, may be longer than 45 minutes, if necessary, for the connector to attain thermal stabilization. In such cases, the time of 45 minutes is not to be prolonged more than necessary for the temperature to become stable.

15 Dielectric Strength Tests

15.1 General

15.1.1 No sample shall be subjected to more than one dielectric strength test.

15.1.2 For a terminal intended to be secured to combinations of conductors of different total cross-sectional area, or single conductors of different AWG sizes, the entire specified series of tests is to be repeated. For one series, samples of the terminal are to be secured to the combination of conductors of the smallest total cross-sectional area, or to the smallest conductor, if only one conductor is intended to be secured; and for the second series the samples are to be secured to the combination of largest total cross-sectional area, or to the largest conductor if only one wire is intended to be secured.

15.1.3 An insulated terminal is unacceptable if any sample performs unacceptably in any test.

15.2 Insulation puncture test

15.2.1 An insulated terminal shall withstand an insulation puncture test in accordance with the requirements of 15.2.2 – 15.2.4 and Table 15.1.

Table 15.1
Samples required for insulation puncture test

Insulating material	Number of samples ^a
Thermosetting, for example, porcelain, or cold-molded melamine, phenolic, or urea-compound: Test as received only	6
Thermoplastic, for example, vinyl or nylon: Test as received	6
Test after oven aging, with samples assembled to wire before such aging ^b	6
Test after oven aging, with samples assembled to wire after such aging ^c	6
^a See 15.1.2. ^b See 15.2.3. ^c See 15.2.4.	

15.2.2 The tests to be conducted and the number of samples for each test are to be as specified in Table 15.1. The test potential is to be 2200 volts for a terminal rated 300 volts and is to be 3400 volts for a terminal rated 600 volts – 1000 volts for signs and lighting fixtures (luminaires). Each sample is to be assembled to a conductor or conductors in the intended manner, and the test potential is to be applied for 1 minute between conductor or conductors and the outer electrode. Each sample is to be embedded in No. 7-1/2 conductive shot that is to serve as the outer electrode. Only that portion of the outer insulating surface that covers live parts is to be covered with the outer electrode. An insulated terminal that has openings that would allow the entrance of shot, thereby possibly resulting in flashover, is to have those openings closed with tape, petrolatum, epoxy, silicone, rubber, or other acceptable material; and the exposed tang of an insulated terminal is to be similarly treated. The supplementary insulating material is not to be applied so as to supplement the terminal insulation where it covers live parts. Puncture of the conductor insulation during this test is not acceptable. If flashover between the electrode and the insulated terminal occurs, the supplementary insulation is to be repaired and the test is to be repeated.

Exception No. 1: A smaller (higher size number) shot may be used with concurrence of those concerned.

Exception No. 2: For an insulated terminal employing a separable cap that is applied after assembly of the terminal to the conductor and has openings that cannot be effectively closed to prevent entry of the shot, metal foil, closely applied to the outer surface of the insulation, may be used as the outer electrode.

15.2.3 With reference to footnote b to Table 15.1, the samples previously assembled to a wire shall be conditioned in an air-circulating oven, in accordance with Table 15.2. If the insulation is a material other than those mentioned in Table 16.1, a test program shall be developed.

15.2.4 With reference to footnote c to Table 15.1, the samples not previously assembled to conductors shall be conditioned for 168 hours in an air-circulating oven at 100°C (212°F). Connectors employing extended covers or sleeves may have the wires pre-inserted, but not crimped, prior to the oven aging. The samples shall be allowed to cool to room temperature. If the insulation is of a hygroscopic material such as nylon, samples shall be subjected to conditioning at a relative humidity of 85 ±5% at 30 ±2°C (86 ±4°F) for 24 hours. After conditioning, the samples shall be assembled (or crimped) to a conductor in the intended manner.

15.2.5 The oven-conditioning described in 15.2.3 and 15.2.4 and Table 15.2, shall not cause the insulation on a terminal to harden, soften, crack, deform, loosen, or otherwise change so as to adversely affect the insulating properties. Discoloration of the insulation shall be acceptable. If agreeable to those concerned, the oven conditioning may be conducted for 60 days as indicated in Table 15.2.

Table 15.2
Temperatures for oven conditioning

Table 15.2 revised January 15, 1999

Rated temperature of connector insulation		Oven temperature			
		7-day test		Optional 60-day test	
°C	°F	°C	°F	°C	°F
60	140	100	212	70	158
75	167	113	235	81	178
90	194	121	250	97	207
105	221	136	277	113	235
125	257	158	316	133	271
150	302	180	356	158	316

15.3 Flashover (Type A)

15.3.1 An insulated terminal shall withstand a flashover test in accordance with the requirements of 15.3.2 and Table 15.3.

Exception: An insulated terminal having insulation in the form of a tubular sleeve and intended to accommodate No. 10 AWG or smaller wires in each opening shall withstand the flashover test described in 15.4.

Table 15.3
Voltages for flashover test

Terminal rating, volts	Test potential, volts
300	4000
600 [1000 in signs and lighting fixtures (luminaires)]	8000

15.3.2 Six samples are to be tested in the as-received condition. See 15.1.2. Each sample is to be assembled as intended. The value of test potential specified in Table 15.3 is to be applied for 1 minute and the potential is then to be rapidly and steadily increased to some value higher than the maximum value specified in Table 15.3 – but breakdown at a value higher than the specified maximum is acceptable – and is to be immediately removed. The potential is to be applied between a conductor secured by the insulated terminal and an outer electrode. An insulated terminal having insulation in the form of a cap is to be embedded in No. 7-1/2 conductive shot that is to serve as the outer electrode. Any other insulated terminal is to have the surface immediately adjacent to the conductor opening covered with metal foil to serve as the outer electrode. To reduce the likelihood of flashover to the exposed tang of an insulated terminal or the likelihood of insulation puncture, the outer surface of the insulation and the exposed tang may be supplemented with tape, petrolatum, epoxy, silicone, rubber, or other acceptable insulating material so that it does not interfere with the position of the outer electrode immediately adjacent to the conductor opening. If flashover from the outer electrode to the insulated terminal occurs or if insulation puncture occurs, the test is to be repeated. Flashover between the conductor and the outer electrode is not acceptable.

Exception No. 1: At the manufacturer's option, after being held at the required test potential for 1 minute, the potential may be reduced to 0 volts and then rapidly and steadily increased to the higher potential.

Exception No. 2: A smaller (higher size number) shot may be used with agreement of those concerned.

15.4 Flashover (Type B – Tubular sleeve)

15.4.1 Six samples shall be tested in the as-received condition. Each sample, not assembled to a wire or wires shall be placed on a flat metal plate in a position most likely to result in breakdown to the open end when the test voltage is applied between the metal plate and all insulated metal parts of the terminal. A test voltage of 1600 V for a terminal rated 300 V and 3000 V for a terminal rated 600 V (1000 V in signs and lighting fixtures (luminaries)) shall be applied for 1 minute. A breakdown (flashover) shall not be acceptable.

16 Secureness of Insulation Test

16.1 General

16.1.1 A temporary distortion of flexible insulating material during the tests is acceptable. Tearing or breaking of the insulation is acceptable if the terminal performs acceptably in a dielectric strength test. The variety of designs of terminals is such that it is not practicable to specify in detail how the force is to be applied. The arrangement shall be such that the tendency for the insulation to be damaged or to be separated from the body is greatest. Flexible insulation, when installed on a terminal after assembly to a wire or wires, shall be permitted to regain its normal shape before the test.

16.2 Terminals with insulation other than the tubular sleeve type

16.2.1 Insulation other than a tubular sleeve shall not be damaged and shall not become detached from the body of the terminal when a force of 20 pounds (89 N) for a terminal for use with No. 18 AWG or smaller wire and 30 pounds (133 N) for all other terminals, is applied for 1 minute between the insulation and the terminal.

16.3 Terminals with insulation of the tubular sleeve type

16.3.1 Tubular sleeve insulation on terminals intended for use with No. 10 AWG or smaller conductors shall not be damaged and shall not become detached from the terminal when a force is applied for 1 minute between the insulation and the terminal.

16.3.2 To determine compliance with 16.3.1:

- a) A 1-pound (4.5 N) force shall be applied to the following:
 - 1) An unassembled, as-received sample; and
 - 2) A sample that has been assembled to the conductor before oven conditioning in accordance with Table 15.2;
- b) A 5-pound (22.3 N) force shall be applied to the following:
 - 1) An assembled, as-received sample;
 - 2) A sample that has been assembled to the conductor before oven conditioning in accordance with Table 15.2; and
 - 3) A sample that has been assembled to the conductor after conditioning for 7 days at $100 \pm 1^\circ\text{C}$ ($212 \pm 2^\circ\text{F}$) in an air-circulating oven, then cooling to room temperature, and if the insulation is of a hygroscopic material, such as nylon, conditioning for 24 hours at a relative humidity of $85 \pm 5\%$ at a temperature of $30 \pm 2^\circ\text{C}$ ($86 \pm 4^\circ\text{F}$).

16.3.2 revised January 15, 1999

17 Moisture-Absorption Test

17.1 Porcelain or cold-molded composition used as insulation on connectors or tabs shall not absorb more than 3 percent of its weight when tested as described in 17.2.

17.1 added October 24, 1995

17.2 Samples used for the Moisture Absorption Test are to be clean and dry. Each connector insulator or tab insulator is to be broken, weighed, and then submerged in distilled water at room temperature for 24 hours. After removal from the water, the broken insulator is to be dried with a soft cloth to remove all surface water and immediately reweighed.

17.2 added October 24, 1995

Reserved for future use

No Text on This Page

APPENDIX B – MILLIVOLT DROP TEST

B1 General

B1.1 Appendix B provides for optional millivolt drop tests that may be conducted with the Heat Cycling Test as described in 14.3.1 and 14.3.2. These measurements are not a requirement but may be used for design analysis.

B2 Millivolt Drop Test

B2.1 The samples subjected to 500 cycles of operation in the Heat Cycling Test described in 14.3.1 and 14.3.2 may also have the following data taken after 24 hours and at the completion of 500 hours.

a) Millivolt drop from the stripped portion of the lead to the reference point on the tab (measurement "A" in Figure 14.2).

b) Millivolt drop across a 1-foot section of lead wire (measurement "B" in Figure 14.1).

B2.2 For the measurements, reference points (dots) are to be marked on each double-ended tab at the locations shown in Figure 14.2. A 1/4-inch (8-mm) section in the center of the lead assembly is to be stripped and soldered with 60/40 solder.

B2.3 The voltage drop across each termination (friction plus crimp) is to be calculated as follows and should not exceed the value given in Table B2.1.

$$\text{Total voltage drop} = \text{Measurement "A"} - 1/4 \text{ of Measurement "B"}$$

Table B2.1
Maximum voltage drop

Wire size,		Maximum voltage drop, millivolts							
		Brass to brass ^a				Tin to brass ^b and tin to tin ^c			
AWG	(mm ²)	0.250 inch (6.3 mm)		All others		0.250 inch (6.3 mm)		All others	
		24 hr	500 hr	24 hr	500 hr	24 hr	500 hr	24 hr	500 hr
22	(0.32)	17	20	20	24	10	14	14	18
20	(0.52)	17	20	20	24	11	15	15	19
18	(0.82)	19	23	22	26	13	17	17	21
16	(1.3)	21	26	25	29	15	19	19	23
14	(2.1)	25	32	30	37	20	26	21	25
12	(3.3)	25	35	–	–	22	28	–	–
10	(5.3)	32	38	–	–	26	30	–	–

^a Plain brass connector and plain brass tab of 0.250 inch (6.4 mm) size or tin-plated connector and plated steel tab 0.250 inch (6.4 mm) size only.

^b Tin-plated connector and plain brass tab.

^c Tin-plated connector and tin-plated tab.

No Text on This Page