

SECTION 1
INTRODUCTION

INTRODUCTION

SECTION 1

INTRODUCTION

Walt Kester

ORIGINS OF REAL-WORLD SIGNALS AND THEIR UNITS OF MEASUREMENT

In this book, we will primarily be dealing with the processing of *real-world* signals using both analog and digital techniques. Before starting, however, let's look at a few key concepts and definitions required to lay the groundwork for things to come.

Webster's *New Collegiate Dictionary* defines a *signal* as "A detectable (or measurable) physical quantity or impulse (as voltage, current, or magnetic field strength) by which messages or information can be transmitted." Key to this definition are the words: *detectable*, *physical quantity*, and *information*.

SIGNAL CHARACTERISTICS

- **Signal Characteristics**
 - ◆ **Signals are Physical Quantities**
 - ◆ **Signals are Measurable**
 - ◆ **Signals Contain Information**
 - ◆ **All Signals are Analog**

- **Units of Measurement**
 - ◆ **Temperature: °C**
 - ◆ **Pressure: Newtons/m²**
 - ◆ **Mass: kg**
 - ◆ **Voltage: Volts**
 - ◆ **Current: Amps**
 - ◆ **Power: Watts**

Figure 1.1

By their very nature, signals are analog, whether DC, AC, digital levels, or pulses. It is customary, however, to differentiate between *analog* and *digital* signals in the following manner: Analog (or real-world) variables in nature include all measurable physical quantities. In this book, *analog* signals are generally limited to electrical variables, their rates of change, and their associated energy or power levels. Sensors are used to convert other physical quantities (temperature, pressure, etc.) to electrical signals. The entire subject of signal conditioning deals with preparing real-world signals for processing and includes such topics as sensors (temperature

INTRODUCTION

and pressure, for example), isolation and instrumentation amplifiers, etc. (see Reference 1).

Some signals result in response to other signals. A good example is the returned signal from a radar or ultrasound imaging system, both of which result from a known transmitted signal.

On the other hand, there is another classification of signals, called *digital*, where the actual signal has been conditioned and formatted into a digit. These digital signals may or may not be related to real-world analog variables. Examples include the data transmitted over local area networks (LANs) or other high speed networks.

In the specific case of Digital Signal Processing (DSP), the analog signal is converted into binary form by a device known as an analog-to-digital converter (ADC). The output of the ADC is a binary representation of the analog signal and is manipulated arithmetically by the Digital Signal Processor. After processing, the information obtained from the signal may be converted back into analog form using a digital-to-analog converter (DAC).

Another key concept embodied in the definition of *signal* is that there is some kind of *information* contained in the signal. This leads us to the key reason for processing real-world analog signals: the *extraction of information*.

REASONS FOR PROCESSING REAL-WORLD SIGNALS

The primary reason for processing real-world signals is to extract information from them. This information normally exists in the form of signal amplitude (absolute or relative), frequency or spectral content, phase, or timing relationships with respect to other signals. Once the desired information is extracted from the signal, it may be used in a number of ways.

In some cases, it may be desirable to reformat the information contained in a signal. This would be the case in the transmission of a voice signal over a frequency division multiple access (FDMA) telephone system. In this case, analog techniques are used to "stack" voice channels in the frequency spectrum for transmission via microwave relay, coaxial cable, or fiber. In the case of a digital transmission link, the analog voice information is first converted into digital using an ADC. The digital information representing the individual voice channels is multiplexed in time (time division multiple access, or TDMA) and transmitted over a serial digital transmission link (as in the T-Carrier system).

Another requirement for signal processing is to *compress* the frequency content of the signal (without losing significant information) then format and transmit the information at lower data rates, thereby achieving a reduction in required channel bandwidth. High speed modems and adaptive pulse code modulation systems (ADPCM) make extensive use of data reduction algorithms, as do digital mobile radio systems, MPEG recording and playback, and High Definition Television (HDTV).

Industrial data acquisition and control systems make use of information extracted from sensors to develop appropriate feedback signals which in turn control the process itself. Note that these systems require both ADCs and DACs as well as sensors, signal conditioners, and the DSP (or microcontroller). Analog Devices offers a family of MicroConverters™ which include precision analog conditioning circuitry, ADCs, DACs, microcontroller, and FLASH memory all on a single chip.

In some cases, the signal containing the information is buried in noise, and the primary objective is signal recovery. Techniques such as filtering, auto-correlation, convolution, etc. are often used to accomplish this task in both the analog and digital domains.

REASONS FOR SIGNAL PROCESSING

- **Extract Information About The Signal (Amplitude, Phase, Frequency, Spectral Content, Timing Relationships)**
- **Reformat the Signal (FDMA, TDMA, CDMA Telephony)**
- **Compress Data (Modems, Cellular Telephone, HDTV, MPEG)**
- **Generate Feedback Control Signal (Industrial Process Control)**
- **Extract Signal From Noise (Filtering, Autocorrelation, Convolution)**
- **Capture and Store Signal in Digital Format for Analysis (FFT Techniques)**

Figure 1.2

GENERATION OF REAL-WORLD SIGNALS

In most of the above examples (the ones requiring DSP techniques), both ADCs and DACs are required. In some cases, however, only DACs are required where real-world analog signals may be generated directly using DSP and DACs. Video raster scan display systems are a good example. The digitally generated signal drives a video or RAMDAC. Another example is artificially synthesized music and speech. In reality, however, the real-world analog signals generated using purely digital techniques do rely on information previously derived from the real-world equivalent analog signals. In display systems, the data from the display must convey the appropriate information to the operator. In synthesized audio systems, the statistical properties of the sounds being generated have been previously derived using extensive DSP analysis (i.e., sound source, microphone, preamp, ADC, etc.).

METHODS AND TECHNOLOGIES AVAILABLE FOR PROCESSING REAL-WORLD SIGNALS

Signals may be processed using analog techniques (analog signal processing, or ASP), digital techniques (digital signal processing, or DSP), or a combination of analog and digital techniques (mixed signal processing, or MSP). In some cases, the choice of techniques is clear; in others, there is no clear cut choice, and second-order considerations may be used to make the final decision.

With respect to DSP, the factor that distinguishes it from traditional computer analysis of data is its speed and efficiency in performing sophisticated digital processing functions such as filtering, FFT analysis, and data compression in real time.

The term *mixed signal processing* implies that *both* analog and digital processing is done as part of the system. The system may be implemented in the form of a printed circuit board, hybrid microcircuit, or a single integrated circuit chip. In the context of this broad definition, ADCs and DACs are considered to be mixed signal processors, since both analog and digital functions are implemented in each. Recent advances in Very Large Scale Integration (VLSI) processing technology allow complex digital processing as well as analog processing to be performed on the same chip. The very nature of DSP itself implies that these functions can be performed in *real-time*.

ANALOG VERSUS DIGITAL SIGNAL PROCESSING

Today's engineer faces a challenge in selecting the proper mix of analog and digital techniques to solve the signal processing task at hand. It is impossible to process real-world analog signals using purely digital techniques, since all sensors (microphones, thermocouples, strain gages, microphones, piezoelectric crystals, disk drive heads, etc.) are analog sensors. Therefore, some sort of signal conditioning circuitry is required in order to prepare the sensor output for further signal processing, whether it be analog or digital. Signal conditioning circuits are, in reality, analog signal processors, performing such functions as multiplication (gain), isolation (instrumentation amplifiers and isolation amplifiers), detection in the presence of noise (high common-mode instrumentation amplifiers, line drivers, and line receivers), dynamic range compression (log amps, LOGDACs, and programmable gain amplifiers), and filtering (both passive and active).

Several methods of accomplishing signal processing are shown in Figure 1.3. The top portion of the figure shows the purely analog approach. The latter parts of the figure show the DSP approach. Note that once the decision has been made to use DSP techniques, the next decision must be where to place the ADC in the signal path.

ANALOG AND DIGITAL SIGNAL PROCESSING OPTIONS

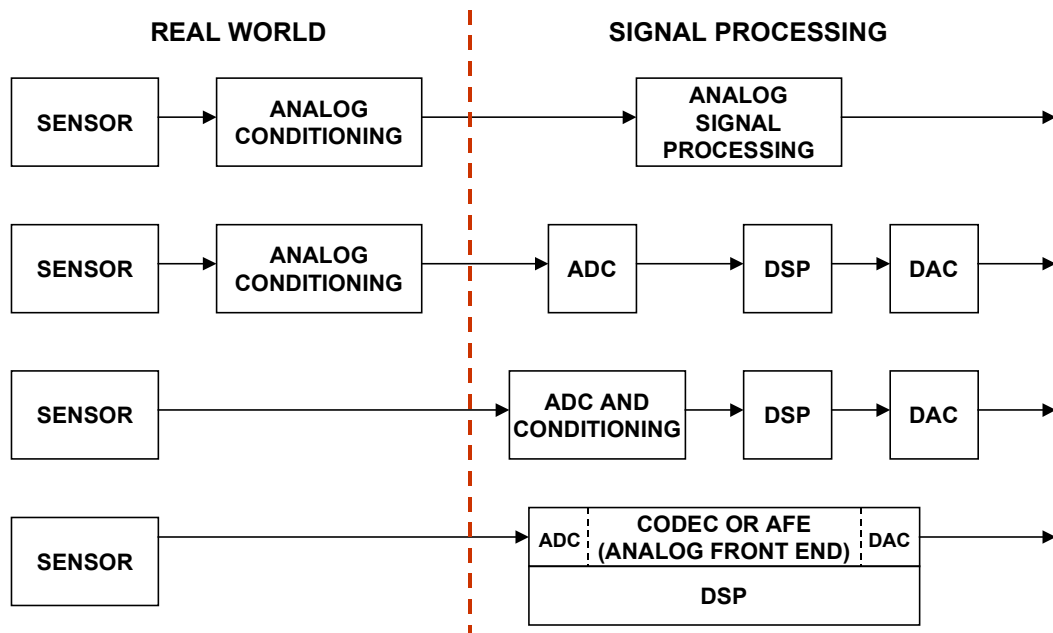

Figure 1.3

In general, as the ADC is moved closer to the actual sensor, more of the analog signal conditioning burden is now placed on the ADC. The added ADC complexity may take the form of increased sampling rate, wider dynamic range, higher resolution, input noise rejection, input filtering and programmable gain amplifiers (PGAs), on-chip voltage references, etc., all of which add functionality and simplify the system. With today's high-resolution/high sampling rate data converter technology, significant progress has been made in integrating more and more of the conditioning circuitry within the ADC/DAC itself. In the measurement area, for instance, 24-bit ADCs are available with built-in programmable gain amplifiers (PGAs) which allow fullscale bridge signals of 10mV to be digitized directly with no further conditioning (e.g. AD773x-series). At voiceband and audio frequencies, complete coder-decoders (Codecs – or Analog Front Ends) are available which have sufficient on-chip analog circuitry to minimize the requirements for external conditioning components (AD1819B and AD73322). At video speeds, analog front ends are also available for such applications as CCD image processing and others (e.g., AD9814, AD9816, and the AD984x series).

A PRACTICAL EXAMPLE

As a practical example of the power of DSP, consider the comparison between an analog and a digital lowpass filter, each with a cutoff frequency of 1kHz. The digital filter is implemented in a typical sampled data system shown in Figure 1.4. Note that there are several implicit requirements in the diagram. First, it is assumed that an ADC/DAC combination is available with sufficient sampling frequency,

INTRODUCTION

resolution, and dynamic range to accurately process the signal. Second, the DSP must be fast enough to complete all its calculations within the sampling interval, $1/f_s$. Third, analog filters are still required at the ADC input and DAC output for antialiasing and anti-imaging, but the performance demands are not as great. Assuming these conditions have been met, the following offers a comparison between the digital and analog filters.

DIGITAL FILTER

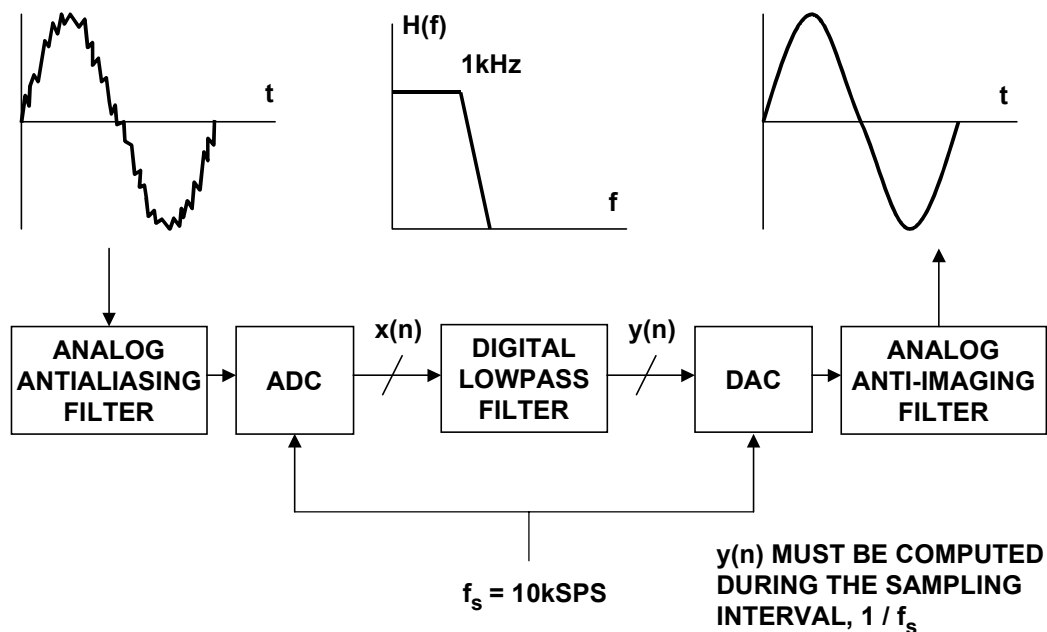

Figure 1.4

The required cutoff frequency of both filters is 1kHz. The analog filter is realized as a 6-pole Chebyshev Type 1 filter (ripple in passband, no ripple in stopband), and the response is shown in Figure 1.5. In practice, this filter would probably be realized using three 2-pole stages, each of which requires an op amp, and several resistors and capacitors. Modern filter design CAD packages make the 6-pole design relatively straightforward, but maintaining the 0.5dB ripple specification requires accurate component selection and matching.

On the other hand, the 129-tap digital FIR filter shown has only 0.002dB passband ripple, linear phase, and a much sharper roll off. In fact, it could not be realized using analog techniques! Another obvious advantage is that the digital filter requires no component matching, and it is not sensitive to drift since the clock frequencies are crystal controlled. The 129-tap filter requires 129 multiply-accumulates (MAC) in order to compute an output sample. This processing must be completed within the sampling interval, $1/f_s$, in order to maintain real-time operation. In this example, the sampling frequency is 10kSPS, therefore $100\mu\text{s}$ is available for processing, assuming no significant additional overhead requirement. The ADSP-21xx-family of DSPs can complete the entire multiply-accumulate

process (and other functions necessary for the filter) in a single instruction cycle. Therefore, a 129-tap filter requires that the instruction rate be greater than $129/100\mu\text{s} = 1.3$ million instructions per second (MIPS). DSPs are available with instruction rates much greater than this, so the DSP certainly is not the limiting factor in this application. The ADSP-218x 16-bit fixed point series offers instruction rates up to 75MIPS.

The assembly language code to implement the filter on the ADSP-21xx-family of DSPs is shown in Figure 1.6. Note that the actual lines of operating code have been marked with arrows; the rest are comments.

ANALOG VERSUS DIGITAL FILTER FREQUENCY RESPONSE COMPARISON

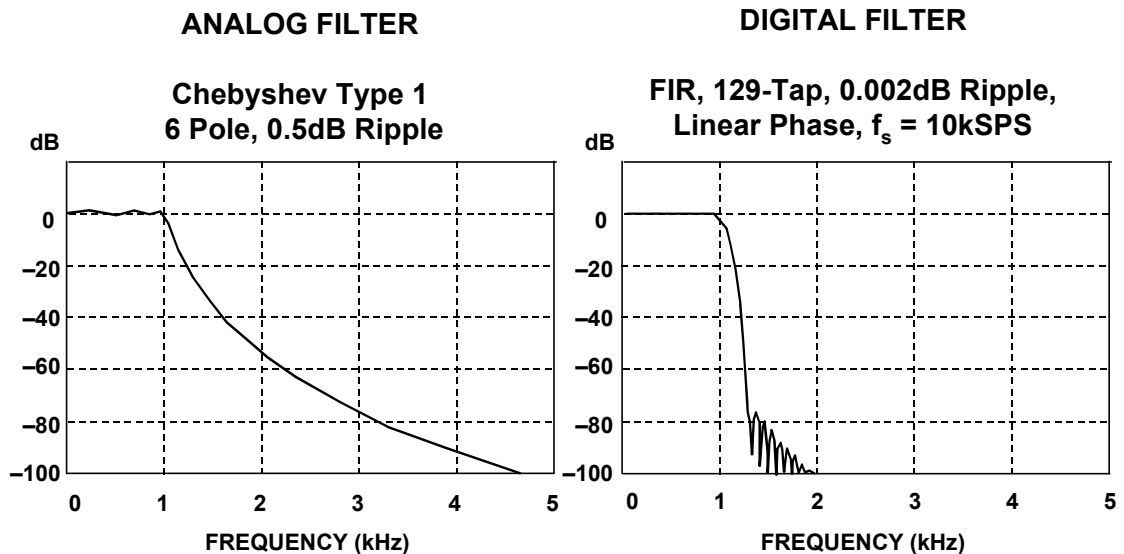

Figure 1.5

In a practical application, there are certainly many other factors to consider when evaluating analog versus digital filters, or analog versus digital signal processing in general. Most modern signal processing systems use a combination of analog and digital techniques in order to accomplish the desired function and take advantage of the best of both the analog and the digital world.

ADSP-21XX FIR FILTER ASSEMBLY CODE (SINGLE PRECISION)

```
.MODULE          fir_sub;
{               FIR Filter Subroutine
               Calling Parameters
                 I0 --> Oldest input data value in delay line
                 I4 --> Beginning of filter coefficient table
                 L0 = Filter length (N)
                 L4 = Filter length (N)
                 M1,M5 = 1
                 CNTR = Filter length - 1 (N-1)
               Return Values
                 MR1 = Sum of products (rounded and saturated)
                 I0 --> Oldest input data value in delay line
                 I4 --> Beginning of filter coefficient table
               Altered Registers
                 MX0,MY0,MR
               Computation Time
                 (N - 1) + 6 cycles = N + 5 cycles
               All coefficients are assumed to be in 1.15 format. }
.ENTRY          fir;
→ fir:         MR=0, MX0=DM(I0,M1), MY0=PM(I4,M5);
→             CNTR = N-1;
→             DO convolution UNTIL CE;
→ convolution: MR=MR+MX0*MY0(SS), MX0=DM(I0,M1), MY0=PM(I4,M5);
→             MR=MR+MX0*MY0(RND);
→             IF MV SAT MR;
→             RTS;
→ .ENDMOD;
```

Figure 1.6

REAL-TIME SIGNAL PROCESSING

- **Digital Signal Processing;**
 - ◆ **ADC / DAC Sampling Frequency Limits Signal Bandwidth**
 - (Don't forget Nyquist!)
 - ◆ **ADC / DAC Resolution / Performance Limits Signal Dynamic Range**
 - ◆ **DSP Processor Speed Limits Amount of Digital Processing Available, Because:**
 - All DSP Computations Must Be Completed During the Sampling Interval, $1 / f_s$, for Real-Time Operation!

- **Don't Forget Analog Signal Processing**
 - ◆ **High Frequency / RF Filtering, Modulation, Demodulation**
 - ◆ **Analog Anti-Aliasing and Reconstruction Filters with ADCs and DACs**
 - ◆ **Where COMMON SENSE and Economics Dictate!**

Figure 1.7

REFERENCES

1. **Practical Design Techniques for Sensor Signal Conditioning**, Analog Devices, 1998.
2. Daniel H. Sheingold, Editor, **Transducer Interfacing Handbook**, Analog Devices, Inc., 1972.
3. Richard J. Higgins, **Digital Signal Processing in VLSI**, Prentice-Hall, 1990.

INTRODUCTION