

# UL 1086

ISBN 1-55989-928-X

## Household Trash Compactors





Underwriters Laboratories Inc. (UL)  
333 Pfingsten Road  
Northbrook, IL 60062-2096

UL Standard for Safety for Household Trash Compactors, UL 1086

Fourth Edition, Dated February 1, 1996

Revisions: This Standard contains revisions through and including January 6, 2004.

### **SUMMARY OF TOPICS**

***The revisions dated January 6, 2004 were issued to incorporate the following new and revised requirements:***

- ***Revisions To Change "Natural Gray" To "Gray" For Identification Of Grounded Conductors***
- ***Addition Of Marking Requirements For HP Ratings Not Less Than The Equivalent HP Ratings Of Combined Loads***

UL Standards for Safety are developed and maintained in the Standard Generalized Markup Language (SGML). SGML -- an international standard (ISO 8879-1986) -- is a descriptive markup language that describes a document's structure and purpose, rather than its physical appearance on a page. Due to formatting differences resulting from the use of UL's new electronic publishing system, please note that additional pages (on which no requirements have been changed) may be included in revision pages due to relocation of existing text and reformatting of the Standard.

Text that has been changed in any manner is marked with a vertical line in the margin. Changes in requirements are marked with a vertical line in the margin and are followed by an effective date note indicating the date of publication or the date on which the changed requirement becomes effective.

The following table lists the future effective dates with the corresponding item.

Future Effective Date	References
January 6, 2005	48.3

The new and/or revised requirements are substantially in accordance with UL's Bulletin(s) on this subject dated October 1, 2003. The bulletin(s) is now obsolete and may be discarded.

The revisions dated January 6, 2004 include a reprinted title page (page1) for this Standard.

As indicated on the title page (page 1), this UL Standard for Safety is an American National Standard. Attention is directed to the note on the title page of this Standard outlining the procedures to be followed to retain the approved text of this ANSI/UL Standard.

As indicated on the title page (page1), this UL Standard for Safety has been adopted by the Department of Defense.

The master for this Standard at UL's Northbrook Office is the official document insofar as it relates to a UL service and the compliance of a product with respect to the requirements for that product and service, or if there are questions regarding the accuracy of this Standard.

UL's Standards for Safety are copyrighted by UL. Neither a printed copy of a Standard, nor the distribution diskette for a Standard-on-Diskette and the file for the Standard on the distribution diskette should be altered in any way. All of UL's Standards and all copyrights, ownerships, and rights regarding those Standards shall remain the sole and exclusive property of UL.

All rights reserved. No part of this publication may be reproduced, stored in a retrieval system, or transmitted in any form by any means, electronic, mechanical photocopying, recording, or otherwise without prior permission of UL.

Revisions of UL Standards for Safety are issued from time to time. A UL Standard for Safety is current only if it incorporates the most recently adopted revisions.

UL provides this Standard "as is" without warranty of any kind, either expressed or implied, including but not limited to, the implied warranties of merchantability or fitness for any purpose.

In no event will UL be liable for any special, incidental, consequential, indirect or similar damages, including loss of profits, lost savings, loss of data, or any other damages arising out of the use of or the inability to use this Standard, even if UL or an authorized UL representative has been advised of the possibility of such damage. In no event shall UL's liability for any damage ever exceed the price paid for this Standard, regardless of the form of the claim.

UL will attempt to answer support requests concerning electronic versions of its Standards. However, this support service is offered on a reasonable efforts basis only, and UL may not be able to resolve every support request. UL supports the electronic versions of its Standards only if they are used under the conditions and operating systems for which it is intended. UL's support policies may change from time-to-time without notification.

UL reserves the right to change the format, presentation, file types and formats, delivery methods and formats, and the like of both its printed and electronic Standards without prior notice.

Purchasers of the electronic versions of UL's Standards for Safety agree to defend, indemnify, and hold UL harmless from and against any loss, expense, liability, damage, claim, or judgement (including reasonable attorney's fees) resulting from any error or deviation introduced while purchaser is storing an electronic Standard on the purchaser's computer system.

If a single-user version electronic Standard was purchased, one copy of this Standard may be stored on the hard disk of a single personal computer, or on a single LAN file-server or the permanent storage device of a multiple-user computer in such a manner that this Standard may only be accessed by one user at a time and for which there is no possibility of multiple concurrent access.

If a multiple-user version electronic Standard was purchased, one copy of the Standard may be stored on a single LAN file-server, or on the permanent storage device of a multiple-user computer, or on an Intranet server. The number of concurrent users shall not exceed the number of users authorized.

Electronic Standards are intended for on-line use, such as for viewing the requirements of a Standard, conducting a word search, and the like. Only one copy of the Standard may be printed from each single-user version of an electronic Standard. Only one copy of the Standard may be printed for each

authorized user of a multiple-user version of an electronic Standard. Because of differences in the computer/software/printer setup used by UL and those of electronic Standards purchasers, the printed copy obtained by a purchaser may not look exactly like the on-line screen view or the printed Standard.

An employee of an organization purchasing a UL Standard can make a copy of the page or pages being viewed for their own fair and/or practical internal use.

The requirements in this Standard are now in effect, except for those paragraphs, sections, tables, figures, and/or other elements of the Standard having future effective dates as indicated in the note following the affected item. The prior text for requirements that have been revised and that have a future effective date are located after the Standard, and are preceded by a "SUPERSEDED REQUIREMENTS" notice.

New product submittals made prior to a specified future effective date will be judged under all of the requirements in this Standard including those requirements with a specified future effective date, unless the applicant specifically requests that the product be judged under the current requirements. However, if the applicant elects this option, it should be noted that compliance with all the requirements in this Standard will be required as a condition of continued Listing and Follow-Up Services after the effective date, and understanding of this should be signified in writing.

Copyright © 2004 Underwriters Laboratories Inc.

This Standard consists of pages dated as shown in the following checklist:

Page	Date
1-2B .....	January 6, 2004
3 .....	December 1, 1999
4 .....	February 1, 1996
5 .....	December 17, 1998
6-8.....	February 1, 1996
9 .....	December 17, 1998
10 .....	January 6, 2004
10A-10B .....	December 17, 1998
11-18B .....	January 6, 2004
19 .....	December 17, 1998
20-20B .....	December 1, 1999
21-22B .....	January 6, 2004
23-36 .....	February 1, 1996
37-38B .....	January 6, 2004
39-45 .....	February 1, 1996
46 .....	December 17, 1998
47-48B .....	December 1, 1999
49-50 .....	February 1, 1996
51-52B .....	January 6, 2004
53-54 .....	February 1, 1996
55-56 .....	January 6, 2004
A1-A2.....	January 6, 2004

No Text on This Page

**FEBRUARY 1, 1996**  
(Title Page Reprinted: January 6, 2004)



**ANSI/UL 1086-2003**

**1**

**UL 1086**

**Standard for Household Trash Compactors**

First Edition – September, 1976  
Second Edition – February, 1979  
Third Edition – December, 1991

**Fourth Edition**

**February 1, 1996**

The most recent designation of ANSI/UL 1086 as an American National Standard (ANSI) occurred on December 8, 2003. The ANSI approval for this standard does not include the Cover page, Transmittal Pages, Title Page, Foreword, or Appendix A.

This ANSI/UL Standard for Safety, which consists of the Fourth Edition with revisions through January 6, 2004, is under continuous maintenance, whereby each revision is ANSI approved upon publication. Comments or proposals for revisions on any part of the Standard may be submitted to UL at any time. Written comments are to be sent to the UL Northbrook Standards Department, 333 Pfingsten Road, Northbrook, IL 60062.

An effective date included as a note immediately following certain requirements is one established by Underwriters Laboratories Inc.

The Department of Defense (DoD) has adopted UL 1086 on August 12, 1994. The publication of revised pages or a new edition of this Standard will not invalidate the DoD adoption.

Revisions of this Standard will be made by issuing revised or additional pages bearing their date of issue. A UL Standard is current only if it incorporates the most recently adopted revisions, all of which are itemized on the transmittal notice that accompanies the latest set of revised requirements.

**ISBN 1-55989-928-X**

**COPYRIGHT © 1976, 2004 UNDERWRITERS LABORATORIES INC.**

No Text on This Page



**CONTENTS**

<b>FOREWORD</b> .....	4
-----------------------	---

**INTRODUCTION**

1 Scope .....	5
2 Glossary .....	5
3 General .....	5
3.1 Components .....	5
3.2 Units of measurement .....	6
3.3 References .....	6
4 Field-Attached Accessories .....	6

**CONSTRUCTION**

5 General .....	6
6 Frame and Enclosure .....	7
7 Accessibility of Uninsulated Live Parts and Film-Coated Wire .....	10A
8 Overload-Protective Devices .....	15
9 Mechanical Assembly .....	16
10 Protection Against Corrosion .....	16
11 Power-Supply Connections .....	17
11.1 Cord-connected appliances .....	17
11.2 Permanently connected appliances .....	20
12 Live Parts .....	22
13 Internal Wiring .....	22A
14 Electrical Insulation .....	24
15 Acoustical and Thermal Insulation .....	25
16 Motors .....	25
17 Switches .....	26
18 Capacitors .....	27
19 Lampholders .....	27
20 Grounding .....	28
21 Double Insulation .....	29
22 Spacings .....	29

**PROTECTION AGAINST RISK OF INJURY TO PERSONS**

23 Scope .....	31
24 General .....	31
25 Sharp Edges .....	31
26 Compacting Space .....	31
27 Enclosure and Guards .....	32
28 Interlocks and Controls .....	33
28.1 Controls .....	33
28.2 Interlocks .....	33
29 Temperatures .....	34
30 Stability .....	34
31 Aerosol Containers and Deodorizers .....	35

**PERFORMANCE**

32	General .....	35
33	Leakage Current Test .....	35
34	Continuity Test of Grounding Circuit .....	38
35	Current Input Test .....	38A
36	Starting Current Test .....	39
37	Temperature Test .....	39
38	Dielectric Voltage-Withstand Test .....	43
39	Moisture Resistance Test .....	44
	39.1 Humidity .....	44
	39.2 Water spillage .....	44
40	Tests on Supply Cords .....	45
	40.1 Flexing .....	45
	40.2 Strain relief .....	46
	40.3 Push-back relief .....	46
41	Overload Test on Switches .....	46
42	Tests on Liquid Containers .....	47
43	Burnout Test on Components .....	47
	43.1 General .....	47
	43.2 Electrolytic capacitor .....	48
44	Leakage Test for Capacitors .....	48
45	Permanence of Marking Test .....	48

**MANUFACTURING AND PRODUCTION TESTS**

46	Dielectric Voltage-Withstand Test .....	48A
47	Grounding Continuity .....	50

**RATING**

48	General .....	50
----	---------------	----

**MARKING**

49	General .....	51
----	---------------	----

**INSTRUCTION MANUAL**

50	General .....	53
51	Instructions Pertaining to a Risk of Fire, Electric Shock, or Injury to Persons .....	53
52	Grounding Instructions .....	55
53	Use-Maintenance Instructions .....	56

**APPENDIX A**

Standards for Components.....	A1
-------------------------------	----

No Text on This Page

## FOREWORD

A. This Standard contains basic requirements for products covered by Underwriters Laboratories Inc. (UL) under its Follow-Up Service for this category within the limitations given below and in the Scope section of this Standard. These requirements are based upon sound engineering principles, research, records of tests and field experience, and an appreciation of the problems of manufacture, installation, and use derived from consultation with and information obtained from manufacturers, users, inspection authorities, and others having specialized experience. They are subject to revision as further experience and investigation may show is necessary or desirable.

B. The observance of the requirements of this Standard by a manufacturer is one of the conditions of the continued coverage of the manufacturer's product.

C. A product which complies with the text of this Standard will not necessarily be judged to comply with the Standard if, when examined and tested, it is found to have other features which impair the level of safety contemplated by these requirements.

D. A product employing materials or having forms of construction which conflict with specific requirements of the Standard cannot be judged to comply with the Standard. A product employing materials or having forms of construction not addressed by this Standard may be examined and tested according to the intent of the requirements and, if found to meet the intent of this Standard, may be judged to comply with the Standard.

E. UL, in performing its functions in accordance with its objectives, does not assume or undertake to discharge any responsibility of the manufacturer or any other party. The opinions and findings of UL represent its professional judgment given with due consideration to the necessary limitations of practical operation and state of the art at the time the Standard is processed. UL shall not be responsible to anyone for the use of or reliance upon this Standard by anyone. UL shall not incur any obligation or liability for damages, including consequential damages, arising out of or in connection with the use, interpretation of, or reliance upon this Standard.

F. Many tests required by the Standards of UL are inherently hazardous and adequate safeguards for personnel and property shall be employed in conducting such tests.

## INTRODUCTION

### 1 Scope

1.1 These requirements cover trash compactors that are rated 250 volts or less and intended for household use to reduce the volume of waste prior to disposal; and that are intended to be employed in accordance with the National Electrical Code, NFPA 70.

1.2 A product that contains features, characteristics, components, materials, or systems new or different from those covered by the requirements in this Standard, and that involves a risk of fire, electric shock, or injury to persons shall be evaluated using the appropriate additional component and end-product requirements to determine that the level of safety as originally anticipated by the intent of this Standard is maintained. A product whose features, characteristics, components, materials, or systems conflict with specific requirements or provisions of this Standard shall not be judged to comply with this Standard. Where appropriate, revision of requirements shall be proposed and adopted in conformance with the methods employed for development, revision, and implementation of this Standard.

1.2 revised December 17, 1998

### 2 Glossary

2.1 For the purpose of this standard the following definitions apply.

2.2 CONVERTIBLE APPLIANCE – A free-standing or portable appliance that is intended to be converted to an undercounter or recessed appliance.

2.3 FREESTANDING APPLIANCE – An appliance that is not intended for attachment to the building structure or to adjacent cabinets or appliances.

2.4 PORTABLE APPLIANCE – A cord-connected appliance mounted on wheels, casters, or the equivalent, and intended to be moved about.

2.5 RECESSED APPLIANCE – An appliance that is intended for installation and use with the rear and both sides located adjacent to cabinets, walls, or other appliances. A recessed appliance may be such as to permit location under a countertop.

2.6 UNDERCOUNTER APPLIANCE – An appliance intended for installation under a countertop, and for attachment to the building structure or to adjacent cabinets, walls, or appliances.

### 3 General

#### 3.1 Components

3.1.1 A component used with an appliance covered by this standard shall comply with the standard or other requirements for the component. See Appendix A for a list of standards covering components generally used in the products covered by this standard.

*Exception: A component need not comply with a specific requirement that:*

*a) Involves a feature or characteristic not needed in the application of the component in the product covered by this standard.*

*b) Is superseded by a requirement in this standard.*

3.1.2 A component shall be used in accordance with its recognized rating established for the intended conditions of use.

3.1.3 Specific components are recognized as being incomplete in construction features or restricted in performance capabilities. Such components are intended for use only under limited conditions, such as certain temperatures not exceeding specified limits, and shall be used only under those specific conditions for which they have been recognized.

### **3.2 Units of measurement**

3.2.1 If a value for measurement as given in these requirements is followed by an equivalent value in other units, in parentheses, the second value may be only approximate. The first stated value is the requirement.

### **3.3 References**

3.3.1 In the following text, a requirement that applies only to a specific type of trash compactor is so identified by a specific reference in that requirement to the type involved. Absence of such specific reference or use of the term appliance indicates that the requirement applies to all trash compactors covered by this standard unless the context indicates otherwise.

3.3.2 Any undated reference to a code or standard appearing in the requirements of this standard shall be interpreted as referring to the latest edition of that code or standard.

## **4 Field-Attached Accessories**

4.1 The requirements in 4.2 – 4.6 apply to accessories intended for installation on or connected to an appliance for the purpose of modifying or supplementing the functions of the appliance or accessory.

4.2 An appliance having provision for the use of accessories to be attached in the field shall be constructed so that the use of these accessories will not introduce a risk of fire, electric shock, or injury to persons.

4.3 Acceptable receptacles and plug-in connectors shall be provided for the installation of an accessory intended to be installed by the operator.

4.4 Terminals in an appliance and wire connectors are an acceptable means for the installation of an accessory intended to be installed by qualified personnel.

4.5 An installation that necessitates field rearrangement of components or wiring, cutting or splicing of wiring, or soldering of connections is not acceptable.

4.6 An accessory is to be tested and trial-installed to determine whether its installation is feasible, whether the instructions are detailed and correct, and whether use of the accessory introduces a risk of fire, electric shock, or injury to persons.

## **CONSTRUCTION**

### **5 General**

5.1 An appliance shall employ materials that are acceptable for the use.

## 6 Frame and Enclosure

6.1 An appliance shall be formed and assembled so that it will have the strength and rigidity necessary to resist the abuses to which it may be subjected, without increasing a risk of fire, electric shock, or injury to persons due to total or partial collapse with resulting reduction of spacings, loosening or displacement of parts, or other serious defects.

6.2 An appliance shall be provided with an enclosure of material acceptable for the application that shall house all parts that may present a risk of fire, electric shock, or injury to persons under any condition of use.

6.3 Among the factors to be taken into consideration when an enclosure is being judged are the:

- a) Mechanical strength,
- b) Resistance to impact,
- c) Moisture-absorptive properties,
- d) Combustibility,
- e) Resistance to corrosion, and
- f) Resistance to distortion at temperatures to which the enclosure may be subjected during normal or abnormal use.

For a nonmetallic enclosure, all of these factors are to be considered with respect to thermal aging.

6.4 A cast- or sheet-metal section of an enclosure shall have a thickness not less than that specified in Table 6.1.

*Exception: An enclosure or part of an enclosure that complies with the requirements in 27.6 – 27.8.*

6.5 Electrical parts of an appliance shall be located or enclosed so that protection against unintentional contact with uninsulated live parts and internal wiring will be provided.

6.6 The enclosure of an appliance shall be such as to prevent molten metal, burning insulation, flaming particles, or the like from falling on combustible materials, including the surface upon which the appliance is supported and inside the compacting compartment.

**Table 6.1**  
**Thickness of metal enclosure**

Metal	Minimum thickness, inch (mm)					
	At small, flat unreinforced surfaces and at surfaces of a shape or size that provides adequate mechanical strength		At surfaces to which a wiring system is to be connected in the field		At relatively large unreinforced flat surfaces	
Die-cast metal	3/64	(1.2)	–		5/64	(2.0)
Cast malleable iron	1/16	(1.6)	–		3/32	(2.4)
Other cast metal	3/32	(2.4)	–		1/8	(3.2)
Uncoated sheet steel	0.026	(0.66)	0.032	(0.81)	0.026	(0.66)
Galvanized sheet steel	0.029	(0.74)	0.034	(0.86)	0.029	(0.74)
Nonferrous sheet metal other than copper	0.036	(0.91)	0.045	(1.14)	0.036	(0.91)
Copper	0.033	(0.84)	0.043	(1.09)	0.033	(0.84)

6.7 The requirement in 6.6 necessitates that a switch, a relay, a solenoid, or the like, be completely and individually enclosed except for terminals, unless it can be shown that breakdown of the component would not result in a risk of fire, or unless there are no openings in the enclosure through which molten metal, burning insulation, flaming particles, or the like, can fall. See 43.1.1 and 43.1.2. It will also necessitate the use of a barrier of noncombustible material:

a) Under a motor unless:

1) The structural parts of the motor or of the appliance provide the equivalent of such a barrier;

2) The protection provided with the motor is such that no burning insulation or molten material falls to the surface that supports the appliance or into the compacting compartment when the motor is energized under each of the following fault conditions:

i) Open main winding,

ii) Open auxiliary winding,

iii) Starting switch short-circuited, and

iv) Capacitor of a permanent-split-capacitor motor short-circuited and the rotor locked – the short-circuit is to be applied before the motor is energized; or



3) The motor is provided with a thermal motor protector – a protective device that is sensitive to temperature and current – that will prevent the temperature of the motor windings from exceeding:

i) 125°C (257°F) when the motor is running at the maximum load at which it can operate without causing the protector to cycle, and

ii) 150°C (302°F) with the rotor of the motor locked.

b) Under wire, unless its insulation is flame-retardant, such as neoprene- or thermoplastic-insulated wires.

6.8 The barrier mentioned in 6.7 shall be horizontal, shall be located as illustrated in Figure 6.1, and shall have an area in accordance with that illustration. Openings for drainage, ventilation, and the like, may be employed in the barrier provided such openings would not permit molten metal, burning insulation, or the like to fall on combustible material.

**Figure 6.1**  
**Location and extent of barrier**

Figure 6.1 revised December 17, 1998

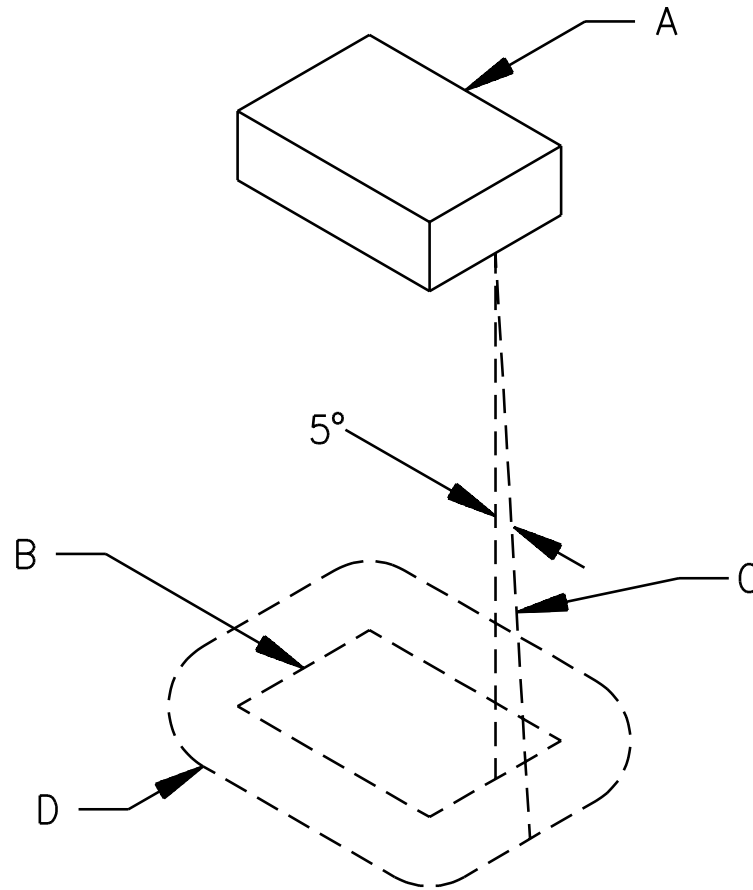

SA0604-1

NOTES -

A - Region to be shielded by barrier. This will consist of the entire component if it is not otherwise shielded, and will consist of the unshielded portion of a component which is partially shielded by the component enclosure or equivalent.

B - Projection of outline of component on horizontal plane.

C - Inclined line that traces out minimum area of barrier. When moving, the line is always:

- 1) tangent to the component,
- 2) 5 degrees from the vertical, and
- 3) so oriented that the area traced out on a horizontal plane is maximum.

D - Location (horizontal) and minimum area for barrier. The area is that included inside the line of intersection traced out by the inclined line C and the horizontal plane of the barrier.

## 7 Accessibility of Uninsulated Live Parts and Film-Coated Wire

7.1 To reduce the likelihood of unintentional contact that may involve a risk of electric shock from an uninsulated live part or film-coated wire, an opening in an enclosure shall comply with either (a) or (b).

- a) For an opening that has a minor dimension (see 7.5) less than 1 inch (25.4 mm), such a part or wire shall not be contacted by the probe illustrated in Figure 7.1.
- b) For an opening that has a minor dimension of 1 inch or more, such a part or wire shall be spaced from the opening as specified in Table 7.1.

*Exception: A motor other than one used in a hand-supported portion of an appliance need not comply with these requirements if it complies with the requirements in 7.2.*

7.2 With respect to a part or wire as mentioned in 7.1, in an integral enclosure of a motor as mentioned in the exception to 7.1:

- a) An opening that has a minor dimension (see 7.5) less than 3/4-inch (19.1 mm) is acceptable if:
  - 1) Film-coated wire cannot be contacted by the probe illustrated in Figure 7.2;
  - 2) In a directly accessible motor (see 7.6), an uninsulated live part cannot be contacted by the probe illustrated in Figure 7.3; and
  - 3) In an indirectly accessible motor (see 7.6), an uninsulated live part cannot be contacted by the probe illustrated in Figure 7.4.
- b) An opening that has a minor dimension of 3/4 inch or more is acceptable if a part or wire is spaced from the opening as specified in Table 7.1.

7.3 The probes mentioned in 7.1 and 7.2 and illustrated in Figures 7.1 – 7.4 shall be applied to any depth that the opening will permit, and shall be rotated or angled before, during, and after insertion through the opening to any position that is necessary to examine the enclosure. The probes illustrated in Figures 7.1 and 7.3 shall be applied in any possible configuration; and, if necessary, the configuration shall be changed after insertion through the opening.

No Text on This Page

Figure 7.1  
Articulate probe with web stop

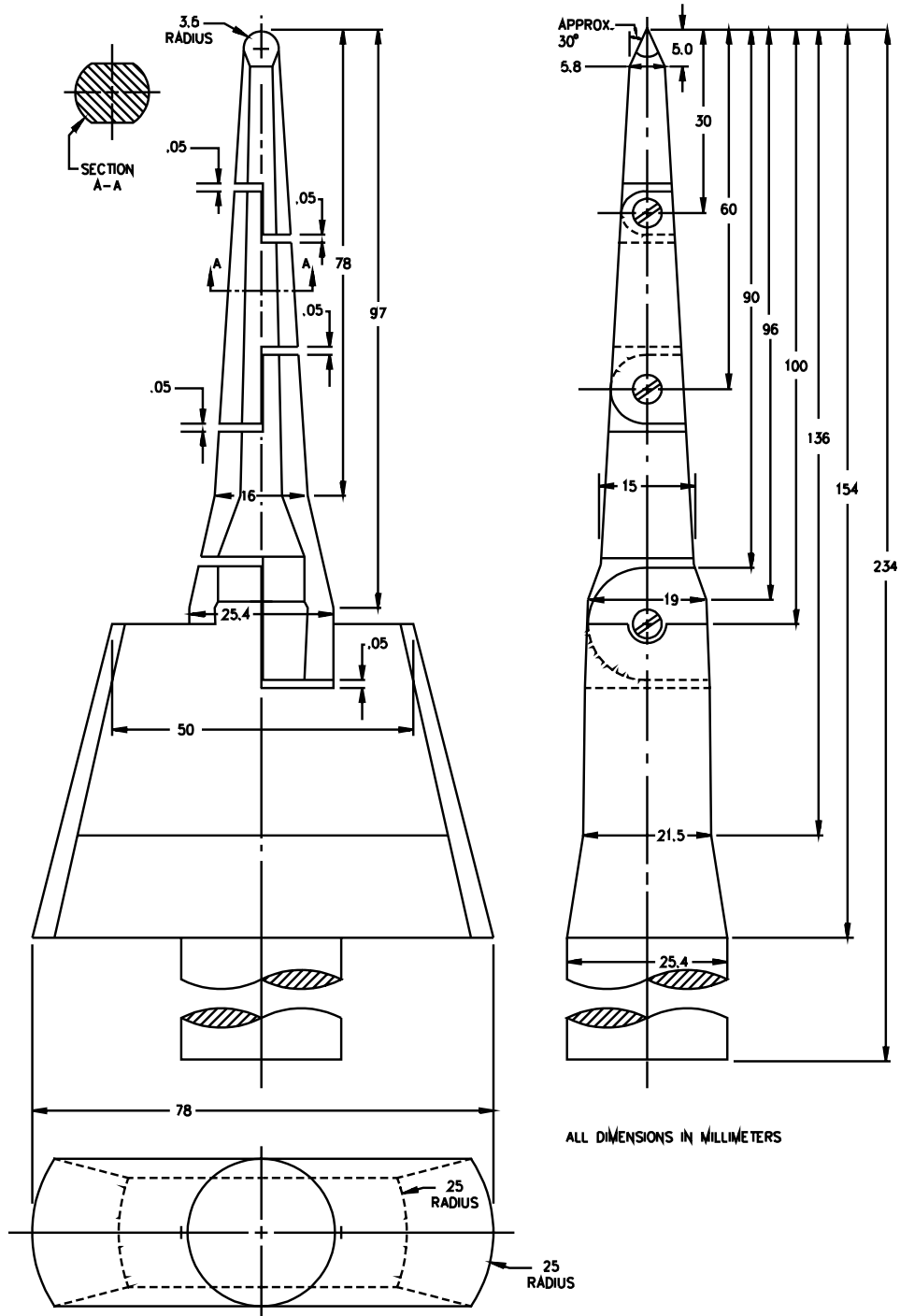

PA100A

Figure 7.2  
Probe for film-coated wire

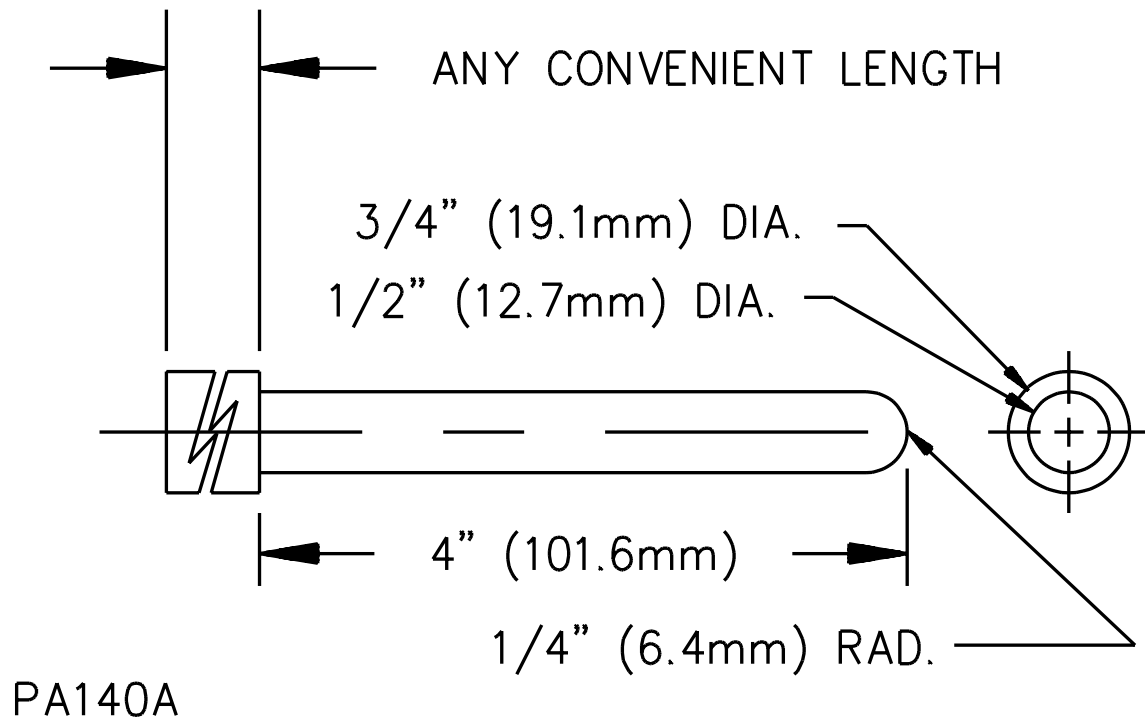

Table 7.1

Minimum acceptable distance from an opening to a part that may involve a risk of electric shock

Minor dimension <sup>a</sup> of opening		Minimum distance from opening to part	
Inches	(mm) <sup>b</sup>	Inches	(mm) <sup>b</sup>
3/4 <sup>c</sup>	(19.1)	4-1/2	(114)
1 <sup>c</sup>	(25.4)	6-1/2	(165)
1-1/4	(31.8)	7-1/2	(190)
1-1/2	(38.1)	12-1/2	(318)
1-7/8	(47.6)	15-1/2	(394)
2-1/8	(54.0)	17-1/2	(444)
	<sup>d</sup>	30	(762)

<sup>a</sup> See 7.5.

<sup>b</sup> Between 3/4 inch and 2-1/8 inches, interpolation is to be used to determine a value between values specified in the table.

<sup>c</sup> Any dimension less than 1 inch applies to a motor only.

<sup>d</sup> More than 2-1/8 inches, but not more than 6 inches (152 mm).



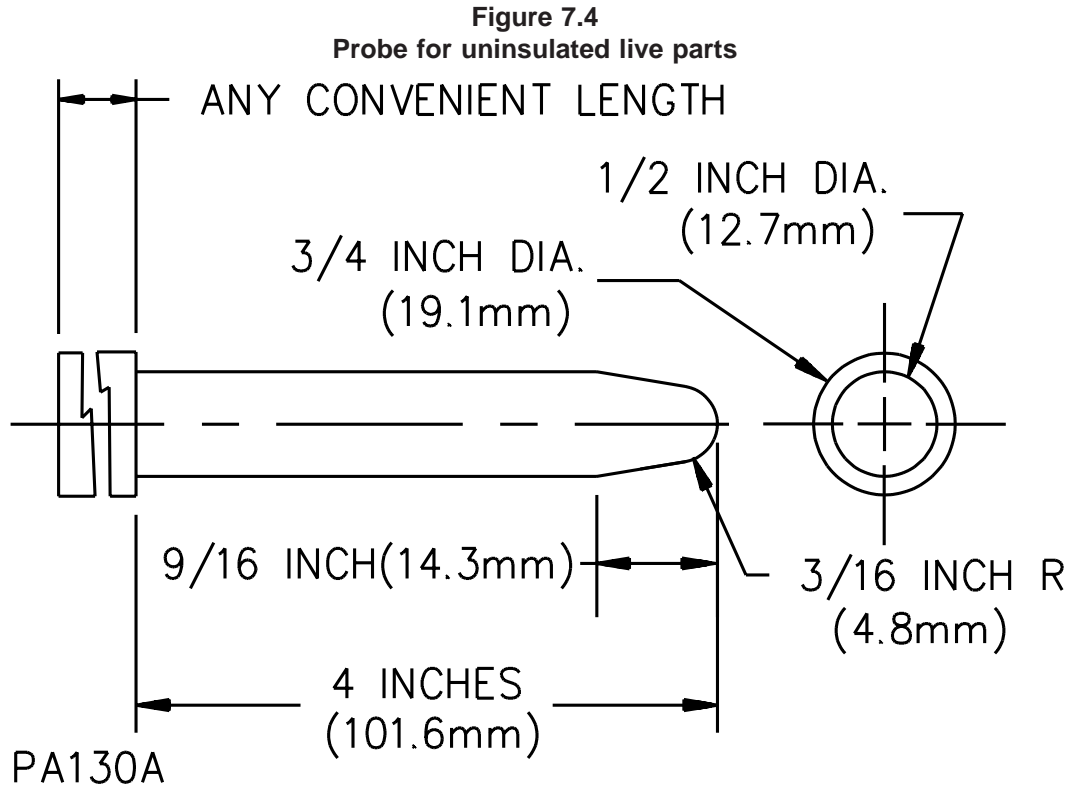

7.4 The probes mentioned in 7.3 and 7.5 shall be used as measuring instruments to judge the accessibility provided by an opening, and not as instruments to judge the strength of a material; they shall be applied with the minimum force necessary to determine accessibility.

7.5 With reference to the requirements in 7.1 and 7.2, the minor dimension of an opening is the diameter of the largest cylindrical probe having a hemispherical tip that can be inserted through the opening.

7.6 With reference to the requirements in 7.2, an indirectly accessible motor is a motor that is accessible only by opening or removing a part of the outer enclosure, such as a guard or panel, that can be opened or removed without using a tool, or is located at such a height or is otherwise guarded or enclosed so that it is unlikely to be contacted. A directly accessible motor is a motor that can be contacted without opening or removing any part or is located so as to be accessible to contact.

7.7 During the examination of an appliance to determine whether it complies with the requirements in 7.1 or 7.2, a part of the enclosure that may be opened or removed by the user without a tool (to attach an accessory, to make an operating adjustment, or for other reasons) is to be opened or removed.

7.8 With reference to the requirements in 7.1 and 7.2, insulated brush caps are not required to be additionally enclosed.



7.9 In an appliance, an opening as described in 7.10 that will not permit the entrance of a 1-inch (25.4-mm) diameter rod is acceptable if a probe as illustrated in Figure 7.5, when inserted through the opening with a force of 5 pounds (22.24 N) and any force less than 5 pounds, cannot be made to:

- a) Touch any uninsulated live part or film-coated wiring; or
- b) Deform or relocate any dead metal part so as to:
  - 1) Permit the probe or dead metal part to touch an uninsulated live part or film-coated wiring; or
  - 2) Reduce electrical spacings below the minimum acceptable value.

**Figure 7.5  
Knife probe**

Figure 7.5 revised December 17, 1998

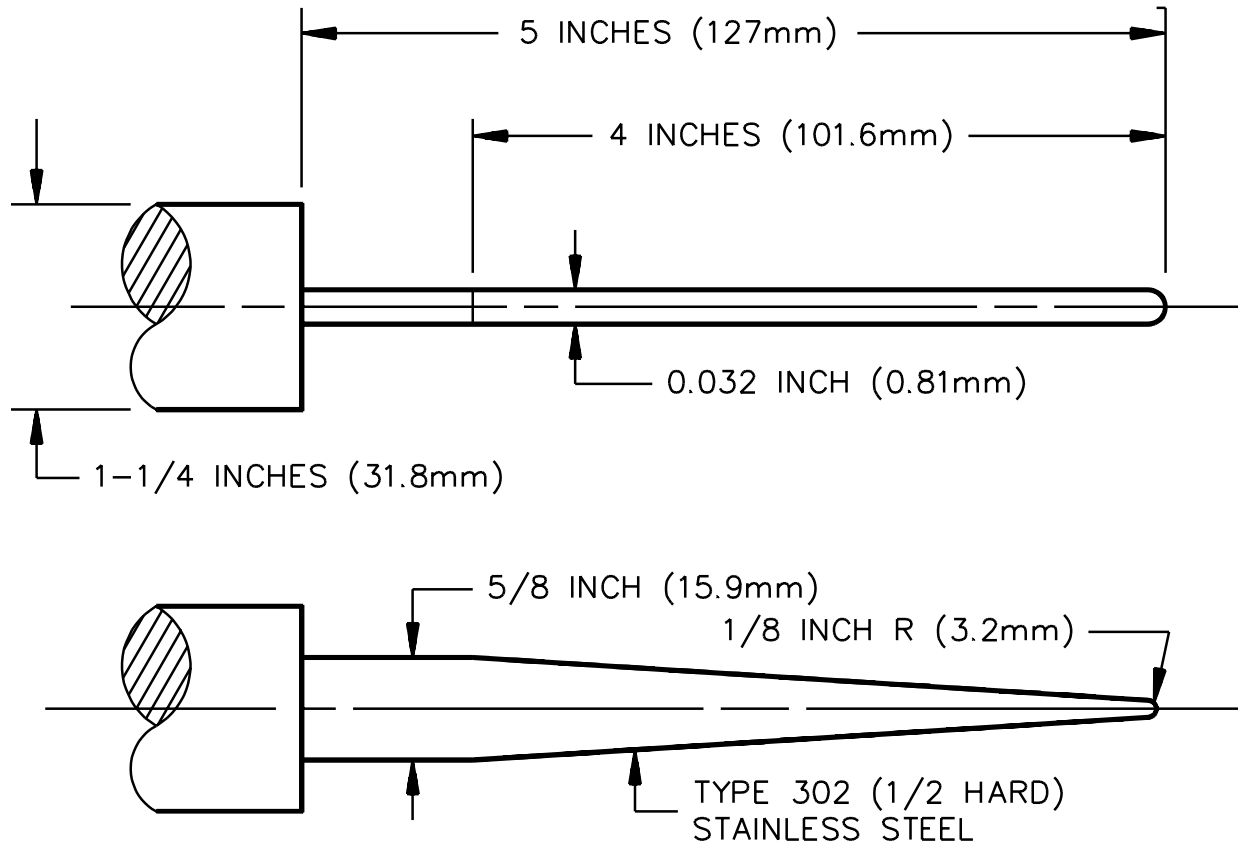

PA220

7.10 The requirement in 7.9 applies to an opening in:

a) The interior surfaces of the compacting compartment and door or door assembly that are accessible when the loading door is open; and

b) The following exterior surface with decorative parts in place:

1) For an under counter and a recessed appliance, the front and those portions of the sides accessible from the front when the appliance is installed in a simulated cabinet enclosure with a 3/8-inch (9.5-mm) clearance between each side and the simulated enclosure.

2) For any other appliance, the back, sides, and front.

*Exception: The front of a rear-mounted control panel need not comply.*

## 8 Overload-Protective Devices

8.1 An overcurrent- or thermal-protective device acceptable for the application shall be provided as part of an appliance.

8.2 A protective device the intended functioning of which requires replacement or resetting shall be in a readily accessible location.

*Exception No. 1: An appliance that complies with all applicable requirements in this standard with the protective device, such as a supplementary fuse, shunted out of the circuit.*

*Exception No. 2: A protective device the location of which would ordinarily be unknown to the user because of its location and the omission of reference to the device in the operating instructions for the appliance.*

8.3 A protective device shall be inaccessible from outside the appliance without opening a door or cover, and resetting shall not require exposure of normally protected or enclosed live parts.

*Exception: The operating handle of a circuit breaker, the operating button of a manually operable motor protector, and similar parts may project outside the enclosure.*

8.4 A door or cover of an enclosure shall be hinged or attached in an equivalent manner if it gives access to any overload protective device, the intended functioning of which requires renewal, or if it is necessary to open the cover in connection with the normal operation of the protective device.

8.5 Means shall be provided for holding a door or cover over a fuseholder closed, and the door or cover shall fit tightly.

## 9 Mechanical Assembly

9.1 An appliance shall be assembled so that it will not be adversely affected by the vibration of normal operation. Brush caps shall be tightly threaded or otherwise intended to prevent loosening.

9.2 A switch, a lampholder, a motor-attachment plug, and similar components shall be mounted securely, and shall be prevented from turning or shifting. See 9.3.

*Exception No. 1: The requirement that a switch be prevented from turning may be waived if all four of the following conditions are met:*

- a) The switch is a plunger or other type that does not tend to rotate when operated – a toggle switch is considered to be subject to forces that tend to rotate the switch during intended operation of the switch;*
- b) The means of mounting the switch makes it unlikely that operation of the switch will loosen it;*
- c) Spacings are not reduced below the minimum acceptable values if the switch does rotate; and*
- d) Intended operation of the switch is by mechanical means rather than direct contact by persons.*

*Exception No. 2: A lampholder in which the lamp cannot be replaced, such as a neon pilot or indicator light in which the lamp is sealed in a nonremovable jewel, need not be prevented from turning if rotation cannot reduce spacings below the minimum acceptable values.*

9.3 The means for preventing the turning mentioned in 9.2 is to consist of more than friction between surfaces – for example, a properly applied lock washer, is an acceptable means for preventing a small stem-mounted switch or other device having a single-hole mounting means from turning.

## 10 Protection Against Corrosion

10.1 All surfaces of iron and steel parts shall be protected against corrosion by enameling, galvanizing, plating, or other acceptable means.

*Exception No. 1: Bearings, balance weights, laminations, or minor parts of iron or steel, such as washers or screws.*

*Exception No. 2: Other parts of iron or steel if corrosion of such parts would not be likely to result in a risk of fire, electric shock, or injury to persons.*

## 11 Power-Supply Connections

### 11.1 Cord-connected appliances

#### 11.1.1 Cords and plugs

11.1.1.1 A power-supply cord or cord set of a cord-connected appliance shall include an equipment-grounding conductor and shall terminate in a grounding attachment plug.

11.1.1.2 The attachment plug of an appliance intended to be connected to a nominal 120 volt circuit, and employing devices required to be connected to a specific supply conductor as specified in 17.2 and 19.1 shall be a polarized type. The connections to the attachment plug shall be in accordance with Figure 11.1. The polarity identification of the supply cord shall be in accordance with Table 11.1. See 53.4

11.1.1.2 revised December 1, 1999

**Figure 11.1**  
**Connections to attachment plugs**

Figure 11.1 revised December 17, 1998

CONNECTIONS OF CORD CONDUCTORS TO GROUNDING – TYPE  
 ATTACHMENT PLUG (FACE OF PLUG REPRESENTED)

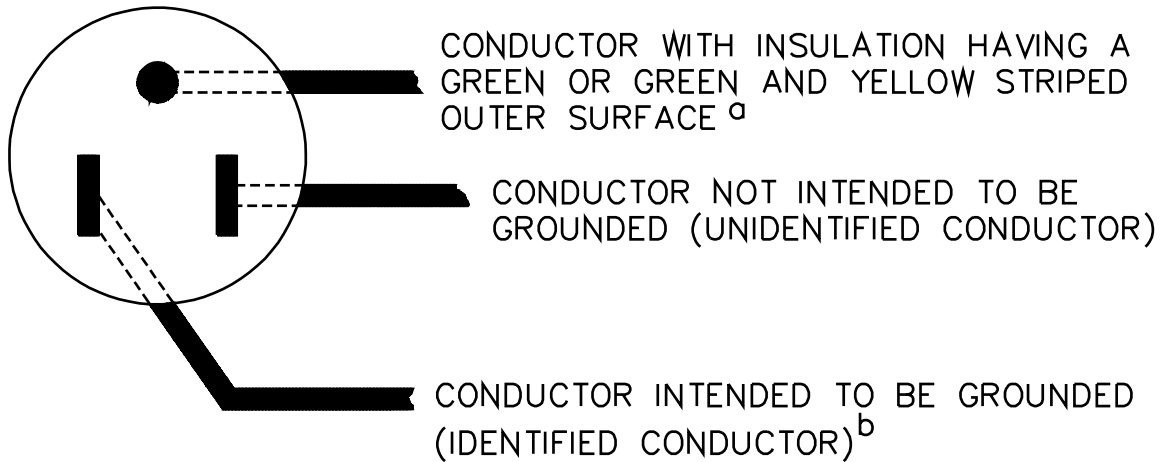

CONNECTIONS OF CORD CONDUCTORS TO POLARIZED  
 ATTACHMENT PLUG (FACE OF PLUG REPRESENTED)

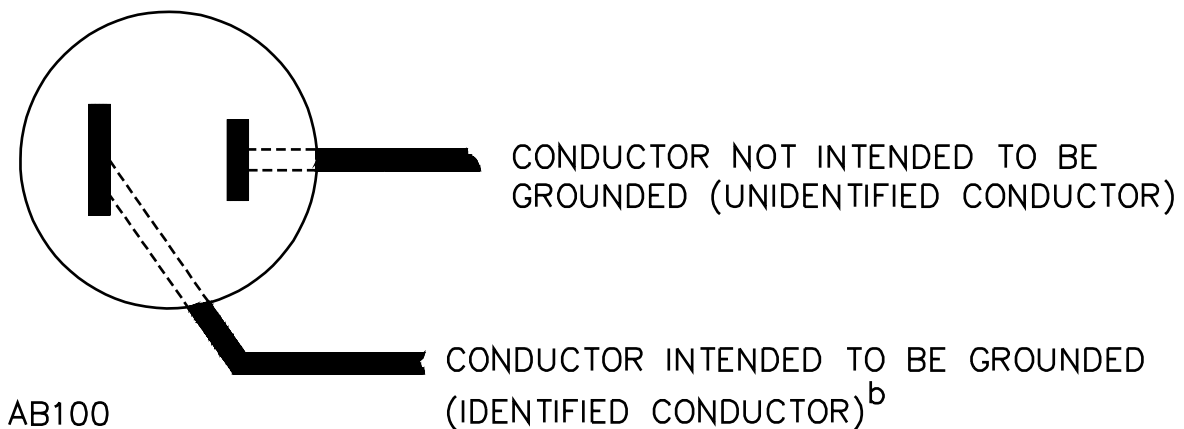

NOTES –

<sup>a</sup> In the above illustration, the blade to which the green conductor is connected may have a U-shape instead of a circular cross section.

<sup>b</sup> Signifies a conductor identified in accordance with Table 11.1.

11.1.1.3 A flexible cord shall be Type SE, SEO, SJ, SJE, SJEO, SJO, SJT, SJTO, SJTOO, S, SO, SOO, SP-3, SPE-3, SPT-3, ST, STO, or STOO, except that a portable appliance shall not employ Types SP-3, SPE-3, and SPT-3 cord.

11.1.1.4 A flexible cord may be permanently attached to an appliance or may be a separate cord set with acceptable means for connection to the appliance.

11.1.1.5 For a freestanding, portable, or convertible appliance the flexible cord shall not be less than 6 feet (1.83 m) long measured from the face of the attachment plug to the point of entry into the appliance. A convertible appliance shall be provided with a means to comply with 11.1.1.6 after conversion.

**Table 11.1**  
**Polarity identification of flexible cords**

Table 11.1 revised January 6, 2004

Method of identification	Acceptable combinations	
	Wire intended to be grounded <sup>b</sup> – wire connected to the screw shells of lampholder	All other wires <sup>b</sup>
Color of braids on individual conductors	Solid white or gray—without tracer	Solid color other than white or gray—without tracer
	Color other than white or gray, with tracer in braid	Solid color other than white or gray—without tracer
Color of insulation on individual conductors	Solid white or gray <sup>a</sup>	Solid color other than white or gray
	Light blue <sup>c</sup>	Solid color other than light blue, white, or gray
Other means	Tin or other white metal on all strands of the conductor <sup>d</sup>	No tin or other white metal on the strands of the conductor
	A stripe, ridge, or groove on the exterior surface of the cord <sup>d</sup>	
<sup>a</sup> Only for cords having no braid on any individual conductor. <sup>b</sup> A wire finished to show a green color with or without one or more yellow stripes or tracers is to be used only as an equipment-grounding conductor. See 20.3 and Figure 11.1. <sup>c</sup> For jacketed cords. <sup>d</sup> Only for Types SP-3, SPE-3, and SPT-3.		

11.1.1.6 For a cord-connected undercounter or recessed appliance:

- a) The flexible cord shall be 3 – 4 feet (0.91 – 1.22 m) long measured from the face of the attachment plug to the point of attachment or entry to the appliance,
- b) Installation instructions shall specify the location of the wall receptacle; and
- c) A means shall be provided to secure the flexible cord to the appliance so that the cord will not be damaged during installation or removal.

No Text on This Page



11.1.1.7 A portable compactor shall not employ an angled attachment plug.

11.1.1.8 The ampacity of the cord and the current rating of the fittings for an appliance rated 15 amperes or less shall not be less than that of the appliance. For an appliance rated more than 15 amperes, the ampacity of the cord shall not be less than the current rating of the appliance; and the current rating of the attachment plug shall not be less than 125 percent of the current rating of the appliance. The attachment plug shall have a voltage rating not less than the rated voltage of the appliance.

11.1.1.9 An appliance that can be adapted for use on two or more different values of voltage by field alteration of internal connections shall be provided with an attachment plug that is acceptable for the voltage for which the appliance is connected when shipped from the factory. See 49.4.

11.1.1.10 An appliance intended for use with a detachable cord set shall not be provided with terminal pins that will accommodate a standard flatiron or appliance plug.

11.1.1.11 An appliance that is required to employ a polarized attachment plug as specified in 11.1.1.2, and that is provided with a detachable cord set as specified in 11.1.1.10 shall also employ an appliance connector of the polarized type.

11.1.1.12 Means shall be provided to prevent a flexible cord from being pushed into an appliance through the cord-entry hole when such displacement results in:

- a) Subjecting the cord to mechanical damage,
- b) Exposing the cord to a temperature higher than that for which the cord is rated,
- c) Reducing spacings, such as to a metal strain-relief clamp, below the minimum required values;  
or
- d) Damaging internal connections or components.

To determine compliance, the cord shall be tested in accordance with Push-Back Relief, Section 40.3.

11.1.1.12 revised December 17, 1998

## 11.1.2 Strain relief

11.1.2.1 Strain relief shall be provided to reduce the likelihood of mechanical stress or twisting on the flexible cord being transmitted to a terminal, a splice, or interior wiring. See 40.2.1.

11.1.2.2 A strain-relief clamp shall be constructed so that it will not damage the cord.

## 11.1.3 Bushings

11.1.3.1 The edges of a bushing or entry hole for the power-supply cord shall be smooth and free from burrs, fins, and sharp edges.

11.1.3.2 If an insulating bushing provided where the power-supply cord enters the enclosure is of material other than ceramic, phenolic, cold-molded composition, fiber, or other material that has been investigated and found to be acceptable for the application, the hole in the metal in which the bushing is mounted shall be smooth and free from burrs, fins, and sharp edges.

## 11.2 Permanently connected appliances

### 11.2.1 General

11.2.1.1 An undercounter appliance and any appliance intended to be fastened or fixed in position shall have provision for connection to a wiring system in accordance with the National Electrical Code, ANSI/NFPA 70.

*Exception: A built-in appliance that is provided with an acceptable power-supply cord need not have such provision.*

### 11.2.2 Field-wiring compartments

11.2.2.1 A field-wiring compartment in which power-supply connections are to be made shall be located so that these connections may be readily inspected after the appliance has been installed as intended.

11.2.2.2 The requirement in 11.2.2.1 necessitates that the field-wiring compartment be located so that it will be accessible without moving the appliance after installation.

11.2.2.3 A field-wiring compartment that is not a part of the enclosure of the appliance shall be complete, and shall enclose all field-wiring terminals and all splices to be made in the field. Openings for ventilation shall not be located in the bottom or sides of the compartment.

11.2.2.4 A field-wiring compartment intended for connection of a supply raceway shall be attached to the appliance so as to be prevented from turning.

### 11.2.3 Field-wiring terminals and leads

11.2.3.1 A permanently connected appliance shall be provided with wiring terminals for the connection of conductors having an ampacity acceptable for the appliance; or the appliance shall be provided with acceptable leads for such connection.

11.2.3.2 A field-wiring terminal is considered to be a terminal to which a wire may be connected in the field, unless the wire and a means of making the connection, such as a pressure terminal connector, soldering lug, soldered loop, crimped eyelet, and the like, factory-assembled to the wire, are provided as part of the appliance.

11.2.3.3 An appliance equipped with terminals or leads for field connection of power-supply conductors shall be provided with a terminal or lead that is located in the field-wiring area for connection of an equipment-grounding conductor. See 11.2.3.4 and 11.2.3.5.

11.2.3.4 A lead intended for field connection of an equipment-grounding conductor shall not be smaller than the wire that should be connected to it in accordance with the National Electrical Code, ANSI/NFPA 70.

11.2.3.5 A terminal intended only for connection of an equipment-grounding conductor shall be capable of securing a conductor of the size acceptable for the application, in accordance with the National Electrical Code, ANSI/NFPA 70.

11.2.3.5 revised December 1, 1999

11.2.3.6 An appliance intended to be adapted upon installation for either of two different supply voltages – for example, 120 volts, 2-wire or 120/240 volts, 3-wire – shall be provided with a terminal block or board on which the appropriate connections may be made without the necessity of changing internal wiring or connections other than at the terminal block or board.

11.2.3.7 A wiring terminal shall be provided with an acceptable pressure terminal connector securely fastened in place– for example, firmly bolted, or held by a screw.

*Exception: A wire-binding screw may be employed at a wiring terminal intended to accommodate a No. 10 AWG (53 mm<sup>2</sup>) or smaller conductor if upturned lugs or the equivalent are provided to hold the wire in position.*

No Text on This Page

11.2.3.8 A wiring terminal shall be prevented from turning.

11.2.3.9 The free length of a lead inside an outlet box or wiring compartment shall be 6 inches (152 mm) or more if the lead is intended for field connection to an external circuit.

*Exception: A lead may be less than 6 inches (152 mm) long if it is evident that the use of a longer lead might result in a risk of fire or electric shock.*

11.2.3.10 A wire-binding screw at a field-wiring terminal shall not be smaller than No. 10.

*Exception: A No. 8 screw may be used at a terminal intended only for the connection of a No. 14 AWG (2.1 mm<sup>2</sup>) conductor.*

11.2.3.11 A wire-binding screw shall thread into metal.

11.2.3.12 A terminal plate tapped for a wire-binding screw shall be of metal not less than 0.050 inch (1.27 mm) thick. There shall be no fewer than two full threads in the metal of the plate.

*Exception: A plate not less than 0.030 inch (0.76 mm) thick is acceptable if the tapped threads provide equivalent mechanical strength.*

11.2.3.13 A terminal plate formed from stock having the thickness specified in 11.2.3.12 may have the metal extruded at the tapped hole to provide two full threads for the binding screw.

11.2.3.14 Uprturned lugs or a cupped washer shall be capable of retaining a supply conductor of the size indicated in 11.2.3.1 under the head of the screw or washer.

#### 11.2.4 Identification

11.2.4.1 An appliance intended for permanent connection to a grounded power-supply conductor and employing a lamp- or element-holder of the screw-shell type, a single-pole switch or overcurrent protective device other than an automatic control without a marked off position, shall have one terminal or lead identified for connection of the grounded conductor of the supply circuit. The identified terminal or lead shall be the one that is electrically connected to screw shells of lamp- or element-holders, and to which is connected no single-pole switch or single-pole overcurrent-protective device other than an automatic control without a marked off position.

11.2.4.2 A terminal intended for connection of a grounded power-supply conductor shall be of or plated with a metal substantially white in color and shall be readily distinguishable from the other terminals, or proper identification of that terminal shall be clearly shown in some other manner, such as on an attached wiring diagram.

11.2.4.3 A lead for connection of a grounded power-supply conductor shall have a white or gray color and shall be readily distinguishable from the other leads.

11.2.4.3 revised January 6, 2004

11.2.4.4 A lead for connection to an ungrounded power supply conductor shall be identified by any color other than white, gray or green with or without yellow stripes.

11.2.4.4 revised January 6, 2004

11.2.4.5 The surface of a lead intended for the connection of an equipment-grounding conductor shall be green with or without one or more yellow stripes, and no other lead shall be so identified.

11.2.4.6 The requirements in 11.2.4.3 – 11.2.4.5 relating to color coding for identification do not apply to internal wiring that is not visible in a wiring compartment in which field connections are to be made.

11.2.4.7 A wire-binding screw intended for the connection of a field connected equipment-grounding conductor shall have a green-colored head that is hexagonal, slotted, or both. A pressure wire connector intended for connection of such a conductor shall be plainly identified, by being marked "G," "GR," "GND," "Ground," "Grounding," or the like; or by a marking on a wiring diagram provided on the appliance. The wire-binding screw or pressure wire connector shall be located so that it is unlikely to be removed during normal servicing of the appliance.

## 12 Live Parts

12.1 A current-carrying part shall be silver, copper, a copper alloy, or other material acceptable for the application.

12.2 Plated iron or steel may be used for a current-carrying part:

- a) The temperature of which is more than 100°C (212°F) during normal operation,
- b) Within a motor or associated governor, or
- c) If acceptable in accordance with 3.1.1. Unplated iron or steel is not acceptable.

Stainless steel and other corrosion-resistant alloys may be used for current-carrying parts regardless of temperature.

12.3 An uninsulated live part shall be secured to the base or mounting surface so that it will be prevented from turning or shifting in position if such motion might result in a reduction of spacings below the minimum acceptable values.

12.4 Friction alone between surfaces is not acceptable as a means to prevent shifting or turning of a live part. A properly applied lock washer is acceptable.

### 13 Internal Wiring

13.1 The internal wiring and connections between parts of an appliance shall be protected or enclosed.

13.2 Internal wiring is considered to be all interconnecting wiring beyond the point where the power-supply cord of a cord-connected appliance enters the enclosure, or beyond field-wiring terminals or leads for power-supply connection of a fixed appliance, even though some of such wiring may not be completely enclosed and even though some of it may be flexible cord. The protection of insulated wiring required by 13.1 is considered to exist if, when judged as though it were film-coated wire, the wiring would be acceptable in accordance with 7.1. Internal wiring not so protected may be accepted if it is secured within the enclosure so that it is unlikely to be subjected to stress or mechanical damage.

13.3 Unless it is to be judged as an uninsulated live part, insulated internal wiring, including a grounding conductor, shall consist of wire of a type or types that are acceptable for the application, when considered with respect to:

- a) Exposure to oil, grease, or other substances that may have a deleterious effect on the insulation;
- b) Exposure to moisture; and
- c) The temperature, voltage, and other conditions of service to which the wiring may be subjected.

No Text on This Page



13.4 Thermoplastic, neoprene, or rubber-insulated wire used for internal wiring shall be standard building wire or acceptable appliance wiring material and shall comply with Table 13.1.

13.5 Type AF wire shall not be employed.

13.6 Wiring shall be protected from sharp edges, including screw threads, burrs, fins, moving parts, and other agents that may abrade the insulation on conductors.

13.7 A hole through which insulated wires pass in a sheet-metal wall within the overall enclosure of an appliance shall be provided with a smooth, rounded bushing; or shall have smooth, rounded surfaces against which the wires may bear, to prevent abrasion of the insulation.

13.8 Insulated wires may be bunched and passed through a single opening in a metal wall within the enclosure.

13.9 All splices and connections shall be mechanically secure and shall provide reliable electrical contact.

13.10 A soldered connection shall be made mechanically secure before being soldered.

13.11 A wire-binding screw or nut shall be provided with a lock washer under the head of the screw or under the nut to prevent it from becoming loosened due to vibration if such loosening might permit parts to shift, thereby reducing spacings, or otherwise resulting in a risk of fire, electric shock, or injury to persons.

13.12 An open-end spade lug is not acceptable unless additional means – such as a lock washer or upturned ends on the tang of the lug – are provided to hold the lug in place should the wire-binding screw or nut become loosened.

13.13 A splice shall be provided with insulation equivalent to that on the wires involved if permanence of spacing between the splice and other metal parts may not be maintained.

13.14 Insulation consisting of two layers of friction tape, of two layers of thermoplastic tape, or of one layer of friction tape wrapped over one layer of rubber tape is acceptable on a splice. In determining if splice insulation consisting of coated-fabric, thermoplastic, or other tubing is acceptable, consideration is to be given to such factors as dielectric properties, heat-resistant and moisture-resistant characteristics, and the like. Thermoplastic tape wrapped over a sharp edge is not acceptable. An insulated splicing device is acceptable within the limits of its voltage and temperature ratings.

13.15 The means of connecting stranded internal wiring to a wire-binding screw shall be such that loose strands of wire cannot contact other live parts not always of the same polarity as the wire or contact dead metal parts. This may be accomplished by using pressure terminal connectors, soldering lugs, crimped eyelets, soldering all strands of the wire together, or other reliable means.

**Table 13.1**  
**Characteristics of internal wiring**

Insulation	Nominal wall thickness of insulation		Braid or jacket required	Nominal thickness of braid or jacket	
	Inch	(mm)		Inch	(mm)
Thermoplastic or neoprene	1/32 <sup>a</sup>	(0.8)	No <sup>a</sup>	–	–
Rubber	1/32 <sup>b</sup>	(0.8)	Yes <sup>b</sup>	1/64 <sup>b</sup>	(0.4)
Cross-linked synthetic polymer	1/64	(0.4)	No	–	–

<sup>a</sup> The wall thickness may be not less than 1/64 inch (0.4 mm) if the wire is provided with a braid or jacket not less than 1/64 inch thick.

<sup>b</sup> For heat-resistant rubber, other than a silicone type, the wall thickness is to be not less than 3/64 inch (1.2 mm) and no braid is required.

13.16 Aluminum conductors, insulated or uninsulated, used as internal wiring, such as for interconnection between current-carrying parts or as motor windings, shall be terminated at each end by a method acceptable for the combination of metals involved at the connection point.

13.17 With reference to 13.16 a wire-binding screw or a pressure wire connector used as a terminating device shall be acceptable for use with aluminum under the conditions involved – for example, temperature, heat cycling, vibration, and the like.

13.18 A nominal 0.110-, 0.125-, 0.187-, 0.205-, or 0.250-inch-wide quick-connect terminal shall comply with the Standard for Electrical Quick Connect Terminals, UL 310. Other sizes of quick-connect terminals shall be investigated with respect to crimp pull-out, engagement-disengagement forces of the connector and tab, and temperature rises. All tests are to be conducted in accordance with UL 310.

## 14 Electrical Insulation

14.1 An insulating washer, bushing, and the like, and a base or support for the mounting of a live part shall be of a moisture-resistant material – such as porcelain, phenolic or cold-molded composition, or other material that is acceptable for the application – that will not be adversely affected by the temperatures to which it will be subjected under conditions of actual use.

14.2 Insulating material is to be judged with respect to its acceptability for the application. Materials such as mica, some molded compounds, and certain refractory materials are usually acceptable as the sole support for live parts; and some other materials that are not acceptable for general use, such as asbestos and magnesium oxide, may be accepted if used in conjunction with other insulating materials or if located and protected so that mechanical damage and the absorption of moisture are prevented. If an investigation is necessary to determine whether a material is acceptable, consideration is to be given to its mechanical strength, dielectric strength, insulation resistance, heat-resistant qualities, the degree to which it is enclosed or protected, and any other features that have a bearing on the risk of fire, electric shock, and injury to persons involved, in conjunction with the conditions of normal service.

14.3 A screw or other fastening used to mount or support a small, fragile, insulating part shall not be so tight as to crack or break such a part because of expansion and contraction. Generally, such a part shall be slightly loose.

14.4 Ordinary vulcanized fiber may be used for an insulating bushing, a washer, a separator, and a barrier, but not as the sole support for uninsulated live parts where shrinkage, current leakage, or warpage may introduce a risk of fire, electric shock, or injury to persons. Thermoplastic materials generally are not considered to be acceptable for the sole support of uninsulated live parts, but may be employed if investigated and found to be acceptable for the application.

14.5 A small molded part, such as a terminal block, shall have mechanical strength and rigidity necessary to withstand the stresses of normal service.

## **15 Acoustical and Thermal Insulation**

15.1 Combustible or electrically conductive acoustical and heat-insulating material shall not be located so as to make contact with an uninsulated live part.

15.2 Mineral-wool thermal insulation shall not contact an uninsulated live part if it contains conductive impurities such as slag that may introduce a risk of fire, electric shock, or injury to persons.

## **16 Motors**

16.1 A motor shall be acceptable for the application and shall be capable of handling the loads described in 37.2 without introducing a risk of fire, electric shock, or injury to persons.

16.2 A motor winding shall resist the absorption of moisture and shall be formed and assembled in a workmanlike manner.

16.3 With reference to the requirement in 16.2, film-coated wire is not required to be additionally treated to prevent absorption of moisture, but fiber slot liners, cloth coil wrap, and similar moisture-absorptive materials shall be impregnated or otherwise treated to prevent the absorption of moisture.

16.4 In the application of requirements based on horsepower to a motor not rated in horsepower, use is to be made of the appropriate table in the National Electrical Code, ANSI/NFPA 70, that gives the relationships between horsepower and full-load currents for motors. For an appliance incorporating two or more motors of different sizes, the spacings inside each motor are to be judged on the basis of the size of that motor, and the spacings elsewhere in the appliance are to be judged on the basis of the size of the largest motor in the appliance.

16.5 Each motor in an appliance shall be provided with overload protection consisting of one of the following:

a) Thermal protection complying with the applicable requirements in the Standard for Thermal Protectors for Motors, UL 547.

*Exception No. 1: If the time required to operate a manually reset protective device through 10 cycles of operation is longer than the time that the product is likely to be operated during each use, the number of operations of the device for the temperature test under locked-rotor conditions may be less than 10 cycles but shall not be less than 4 cycles.*

*Exception No. 2: A motor intended to move air only, by means of an air-moving fan that is integrally attached, keyed, or otherwise fixed to the motor, is required to have locked-rotor protection only.*

*Exception No. 3: A shaded-pole motor with a 2:1 or smaller ratio between locked-rotor and no-load currents and a 1-ampere or smaller difference between no-load and locked-rotor currents is required to have locked-rotor protection only.*

b) Impedance protection complying with the applicable requirements in the Standard for Impedance-Protected Motors, UL 519, when the motor is tested in the appliance under locked-rotor conditions.

c) Other protection that is shown by test to be equivalent to that described in (a).

## 17 Switches

17.1 A switch shall be acceptable for the application, and shall have a current and voltage rating not less than of the load that it controls when the appliance is operated normally.

17.2 In an appliance rated 125 or 125/250 volts (3-wire) or less, a switch or an overcurrent-protective device of the single pole type other than an automatic control without a marked off position, such as a protective device inherent in a motor, shall be electrically connected to a terminal or lead intended for connection to an ungrounded conductor of the supply circuit.

17.3 In applying the requirements in 17.1 to a switching device controlling a motor, the rating of the device shall not be less than the rating of the motor. See 41.1. A switch that controls an inductive load, such as a fluorescent-lamp ballast or a transformer, is ordinarily acceptable without test if the current rating is not less than twice the rated full-load current of the ballast or transformer.

17.4 A switch shall be located or protected so that it will not be exposed to mechanical damage during normal use.

17.5 A switch that controls a medium-base lampholder of other than a pilot or indicating light shall be acceptable for use with tungsten-filament lamps.

17.6 A manually operable motor-control switch shall be provided in a portable appliance employing a motor rated more than 1/3 horsepower. See 16.4.

## 18 Capacitors

18.1 A capacitor provided as a part of a capacitor motor and a capacitor connected across the line – such as a capacitor for radio-interference elimination – shall be housed within an enclosure or container that will protect the plates against mechanical damage and that will prevent the emission of flame or molten material resulting from breakdown of the capacitor. The construction shall comply with one of the following:

- a) The container shall be of sheet steel not less than 0.020 inch (0.51 mm) thick or shall be constructed to afford equivalent protection;
- b) A capacitor having a sheet-steel container thinner than 0.020 inch or other acceptable material shall be mounted in an enclosure that houses other parts of the appliance and that is acceptable for the enclosure of live parts;
- c) The individual enclosure of an electrolytic capacitor with means for venting may be such as to provide protection against mechanical damage only, and no minimum enclosure thickness is specified; or
- d) The individual enclosure of an electrolytic capacitor not provided with means for venting and with an opening more than 1/16 inch (1.6 mm) wide between the capacitor enclosure and the motor shall comply with the requirement in 43.2.1, and no minimum enclosure thickness is specified.

18.2 Under both normal and abnormal conditions of use, a capacitor employing a liquid dielectric medium more combustible than askarel shall not result in a risk of fire or electric shock and shall be constructed to reduce the likelihood of expelling the dielectric medium.

18.3 A capacitor complying with the requirements for protected oil-filled capacitors of the requirements for capacitors, UL 810, is considered to be constructed to reduce the likelihood of expelling the dielectric medium.

## 19 Lampholders

19.1 The screw shell of an Edison-base lampholder in an appliance shall be connected to a conductor that is intended to be connected to the grounded conductor of the power-supply circuit.

19.2 A lampholder shall be such or so installed that uninsulated live parts other than a screw shell will not be exposed to contact by persons removing or replacing lamps in normal service.

*Exception: The requirement does not apply if it is necessary to dismantle the appliance or remove a cover plate or other part by means of a tool in order to remove or replace a lamp.*

## 20 Grounding

20.1 All exposed dead metal parts and all dead metal parts within the enclosure that are exposed to contact during any servicing operation, including maintenance and repair, and that may become energized shall be reliably connected to:

- a) The equipment-grounding terminal or lead and the point to which the power-supply wiring system will be connected in an appliance having provision for permanent connection to the supply.
- b) The equipment-grounding conductor of the power-supply cord in a cord-connected appliance.

*Exception: A double-insulated appliance – see 21.2.*

20.2 With reference to the requirements in 20.1, the following dead metal parts are not considered likely to become energized:

- a) A small metal part – such as an adhesive-attached foil marking, a screw, a handle, – that is:
  - 1) On the exterior of the enclosure and separated from all electrical components by grounded metal, or
  - 2) Electrically isolated from all electrical components.
- b) A panel or a cover that is insulated from all electrical components by a barrier of vulcanized fiber, varnished cloth, phenolic composition, or other moisture-resistant insulating material not less than 1/32 inch (0.8 mm) thick and reliably secured in place.
- c) A panel or a cover that does not enclose uninsulated live parts and is electrically isolated from other electrical components.
- d) Cores and assembly screws of a relay, a solenoid, and the like.

20.3 An equipment-grounding conductor of a flexible cord shall be:

- a) Finished to show a green color with or without one or more yellow stripes;
- b) Connected to the grounding blade of an attachment-plug of the grounding type; and
- c) Connected to dead metal parts specified in 20.1. The connection shall be made by means of a screw not likely to be removed during ordinary servicing not involving the power-supply cord, or by other reliable means. Solder alone is not acceptable for making this connection.

20.4 An appliance provided with a power-supply cord and an attachment plug for connection to the power supply shall have an equipment-grounding conductor. See 20.3.

*Exception: A portable appliance provided with an acceptable system of double insulation as mentioned in 21.1.*

## 21 Double Insulation

21.1 An appliance may be provided with an acceptable system of double insulation in accordance with the applicable requirements in the Standard for Double Insulation Systems for Electrical Equipment, UL 1097, in place of a means for grounding.

21.2 An appliance provided with an acceptable system of double insulation shall not be provided with a means for grounding.

## 22 Spacings

22.1 Spacings at field-wiring terminals shall not be less than the values specified in Table 22.1. See 11.2.3.2 and 22.5.

22.2 The spacing between uninsulated live parts of opposite polarity, and between an uninsulated live part and a dead metal part, shall not be less than the value specified in Table 22.2. If an uninsulated live part is not rigidly fixed in position, by means other than friction between surfaces, or if a movable dead part is in proximity to an uninsulated live part, the construction shall be such that the minimum acceptable spacings will be maintained. See 22.5.

*Exception No. 1: The spacing requirements given in Table 22.2 do not necessarily apply to the inherent spacings of a component of the appliance, such as a snap switch. Such spacings are to comply with the requirements for the component in question if they are less than the values specified in Table 22.2.*

*Exception No. 2: At closed-in points, such as the screw-and-washer construction of an insulated terminal mounted in metal, a spacing of not less than 3/64 inch (1.2 mm) is acceptable.*

*Exception No. 3: Within a thermostat, except at contacts, the spacing between uninsulated live parts on opposite sides of the contacts may be not less than 1/32 inch (0.8 mm) through air and 3/64 inch (1.2 mm) over the surface of insulating material if the construction is such that the spacings will be permanently maintained.*

**Table 22.1**  
**Spacings at field-wiring terminals**

Minimum spacings, inch (mm)		
Between field-wiring terminals of opposite polarity, and between a field-wiring terminal and a dead metal part other than the enclosure		Between a field-wiring terminal and the enclosure – through air or over surface
Through air	Over surface	
1/4 (6.4)	3/8 (9.5)	1/2 (12.7)

22.3 Film-coated wire is regarded as an uninsulated live part when spacings are being considered.

22.4 The spacings for a motor shall comply with the spacing requirements in the Standard for Electric Motors, UL 1004.

22.5 At terminal screws and studs to which connection may be made in the field by wire connectors, eyelets, and the like as described in 11.2.3.2, spacings shall not be less than those specified in Table 22.2 with the connectors, eyelets, and the like in such position that minimum spacings – opposite polarity and to dead metal – exist.

**Table 22.2**  
**Spacings at other than field-wiring terminals**

Potential involved, in volts	Minimum spacings, inch (mm) <sup>a</sup>			
	An appliance employing a motor having a diameter of 7 inches or less <sup>b</sup>		An appliance employing a motor having a diameter of more than 7 inches <sup>b</sup>	
	Over surface	Through air	Over surface	Through air
0 – 125	3/32 <sup>c</sup>	3/32 <sup>c</sup>	1/4 <sup>d</sup>	1/8 <sup>d</sup>
126 – 250	3/32	3/32	1/4 <sup>d</sup>	1/4 <sup>d</sup>

<sup>a</sup> Metric equivalents of the dimensions in this table are:

Inches	Millimeters
1/16	1.6
3/32	2.4
1/8	3.2
1/4	6.4
7	178

<sup>b</sup> This is the diameter, measured in the plane of the laminations, of the circle circumscribing the stator frame, excluding lugs, fins, boxes, and the like, used solely for motor mounting, cooling, assembly, or connection.

<sup>c</sup> For an appliance employing only motors rated 1/3 horsepower or less, these spacings may be not less than 1/16 inch.

<sup>d</sup> Film-coated wire is considered to be an uninsulated live part. However, a spacing of not less than 3/32 inch over surface and through air between film-coated wire, rigidly supported and held in place on a coil, and a dead metal part is acceptable.

22.6 An insulating liner or barrier of vulcanized fiber or similar material employed in place of spacings shall not be less than 1/32 inch (0.8 mm) thick and shall be so located or of such material that it will not be adversely affected by arcing.

*Exception: Fiber not less than 1/64 inch (0.4 mm) thick may be used in conjunction with an air spacing of not less than 50 percent of the spacing required for air alone.*



## PROTECTION AGAINST RISK OF INJURY TO PERSONS

### 23 Scope

23.1 This section gives the requirements for construction and performance for an appliance the operation of which may involve a risk of injury to persons.

23.2 During the examination of an appliance with respect to a risk of injury to persons, the general requirements for such features as materials, enclosures, guards, and the like, will be applied along with appropriate requirements for tests, construction, markings, guards, and the like, that may apply to an appliance. The requirements specified in this standard apply to appliances of common construction. Specific features that are not contemplated will be given appropriate consideration. A specific requirement pertaining to one type of appliance takes precedence over the requirements specified in General, Section 24.

### 24 General

24.1 If the operation and maintenance of an appliance by the user involves a risk of injury to persons, protection shall be provided to reduce the likelihood of such a risk.

24.2 With reference to the requirement in 24.1, consideration shall be given to reasonably foreseeable misuse of the appliance.

### 25 Sharp Edges

25.1 An enclosure, a frame, a guard, a handle, or the like shall not be sufficiently sharp to cause a risk of injury to persons in normal maintenance or use.

25.2 Whenever referee measurements are necessary to determine that a part as mentioned in 25.1 is not sufficiently sharp to constitute a risk of injury to persons, the method described in the requirements for determination of sharpness of edges on equipment, UL 1439, is to be employed.

### 26 Compacting Space

26.1 The compacting action shall be totally enclosed within the appliance. A door, drawer, or other opening providing access to the compacting compartment shall be interlocked so as to stop completely all moving parts that may cause injury to persons within 5 seconds if the moving part can be contacted after the door has been opened 2 inches (50.8 mm) or less. See 26.2.

26.2 With reference to 26.1, for an opening having a minor dimension less than 1 inch (25.4 mm), contact with a moving part that may cause injury to persons is to be determined by using the probe illustrated in Figure 7.1. For a 1 to 2 inch (25.4 to 50.8 mm) opening, the distance from the plane of the opening to a moving part shall be in accordance with Table 26.1. For an opening having a minor dimension between two values in Table 26.1, the distance from an opening to a moving part shall not be less than that determined by appropriate interpolation between corresponding values in the right-hand column of the table. The minor dimension of the opening is considered to be the diameter of the largest cylindrical probe having a hemispherical tip that can be inserted through the opening with a force of 5 pounds (22.24 N).

**Table 26.1**  
**Distance from opening to moving part**

Minor dimension of opening		Minimum distance from opening to moving part	
inches	(mm)	inches	(mm)
1	(25.4)	6-1/2	(165)
1-1/2	(38.1)	10-1/2	(267)
2	(50.8)	14-1/2	(368)

26.3 The volume of the waste compacting chamber shall not exceed 2 cubic feet (0.057 cubic meters).

*Exception: The volume of the waste compacting chamber may exceed 2 cubic feet when a removable waste container is not in place if an interlock is provided to prevent operation of the compactor when the container is not in place or if the waste compacting space is divided into sections that do not exceed 2 cubic feet of an unobstructed or occupiable space. Consideration will be given to container holding brackets, shelves, or the like that will effectively reduce the volume.*

## 27 Enclosure and Guards

27.1 A part capable of creating a risk of injury to persons shall be enclosed or guarded.

27.2 With reference to 27.1 a part presenting a risk of injury to persons shall be considered acceptably guarded if it is within the enclosure or casing of the appliance and cannot be contacted with the probe illustrated in Figure 7.1.

*Exception No. 1: An opening in the integral enclosure of a motor that is not used in a hand-supported portion of an appliance is acceptable if a moving part cannot be contacted by the probe illustrated in Figure 7.4.*

*Exception No. 2: A part or portion of a part that is necessarily exposed to perform the work function need not be enclosed but, when necessary, guarding shall be provided.*

27.3 During the examination of an appliance to determine whether it complies with the requirements in 27.2, a part of the enclosure that may be removed without the use of a tool (to attach an accessory, to make an operating adjustment, or for other reasons) is to be opened or removed.

*Exception: A part need not be opened or removed provided the appliance is marked in accordance with 49.19.*

27.4 The material of a part – an enclosure, frame, guard, or the like – the deterioration of which might result in a risk of injury to persons, shall have such properties as to meet the demand of expected loading conditions.

27.5 The requirement in 27.4 applies to those portions of a part adjacent to moving parts considered to be a risk of injury to persons.

27.6 A part as mentioned in 27.4 or portion of a part as specified in 27.5 shall withstand the applicable impact test described in 27.7 without being affected to the extent that a moving part that may cause injury to persons is exposed.

*Exception: A part that complies with the requirements in 6.4.*

27.7 A smooth steel sphere 2 inches (50.8 mm) in diameter and weighing approximately 1.18 pounds (535 grams) is to be allowed to fall vertically from rest through a distance of 51 inches (1.30 m) to strike the part under test. For a part not able to be struck from above by a free-falling sphere, the sphere is to be suspended by a cord and allowed to fall as a pendulum through a vertical distance of 51 inches.

27.8 Following the impact test described in 27.7, the probe illustrated in Figure 7.1 is to be used to determine whether a moving part that may cause injury to persons is exposed so as to present such a risk.

## **28 Interlocks and Controls**

### **28.1 Controls**

28.1.1 A compactor shall be equipped with a key-lock switch having a removable key or the equivalent to prevent unauthorized use.

28.1.2 The drive mechanism shall be capable of being stopped by the key lock, or a stop-start switch.

28.1.3 Once stopped, the ram shall retract upon restarting if it has traveled more than 1 inch (25.4 mm) from the fully retracted position or if the door cannot be opened.

28.1.4 If the ram can be operated by an override switch after an interlock has stopped the ram, upon restarting, the ram shall retract if it has traveled more than 1 inch (25.4 mm) from the fully retracted position.

### **28.2 Interlocks**

28.2.1 An interlock is a device or arrangement by which the function of one part is controlled by the functioning of another.

28.2.2 The actuator of an interlock switch shall be located or protected so that it cannot be easily defeated.

28.2.3 An interlock is considered to comply with the requirement in 28.2.2 if it cannot be defeated by use of the probe illustrated in Figure 7.1 or if another acceptable arrangement of the interlock or system of interlocks is provided.

28.2.4 An interlock shall not be capable of being defeated by material or trash accumulation that could occur in normal use.

28.2.5 Operation of an interlock in normal use shall not inconvenience the operator so as to encourage deliberate defeat of the interlock.

28.2.6 Unless known to be acceptable for 100,000 cycles of operation, an interlock shall withstand 100,000 cycles of operation controlling a load no less severe than it controls in the appliance, and shall function normally upon completion of the test.

28.2.7 If an automatically reset protective device is employed in an appliance, automatic restarting of the motor shall not result in a risk of injury.

28.2.8 The requirement in 28.2.7 necessitates the use of an interlock if moving parts or the like may cause a risk of injury to persons upon automatic restarting of the motor.

## 29 Temperatures

29.1 During the temperature test, the temperatures of a surface that may be contacted by the user shall not be more than the value specified in Table 29.1. If the test is conducted at a room temperature of other than 25°C (77°F), the results are to be corrected to that temperature.

**Table 29.1**  
**Surface temperatures**

Location	Maximum temperature			
	Composition of surface <sup>a</sup>			
	Metallic		Nonmetallic	
	Degree		Degree	
	C	F	C	F
A handle or knob that is grasped for lifting or holding	50	122	60	140
A handle or a knob that is contacted, but does not involve lifting or holding; and other surfaces subject to contact in operation and user maintenance	60	140	85	185

<sup>a</sup> A handle, a knob, or the like, made of a material other than metal that is plated or clad with metal having a thickness of 0.005 inches (0.13 mm) or less is considered to be a nonmetallic part.

## 30 Stability

30.1 When tipped through an angle of 10 degrees as described in 30.2, an appliance shall not overturn and shall return to its normal at-rest position.

*Exception: An undercounter appliance.*

30.2 The test required by 30.1 is to be conducted with the appliance set up for normal operation both with and without any removable waste collecting containers in place, and with a load of 15 pounds per cubic foot (240.3 kg/m<sup>3</sup>) or unloaded, whichever creates the more unstable situation. Leveling screws are to be adjusted to raise the appliance as high as possible or 1 inch (25.4 mm) above floor level, whichever is less. Casters or wheels are to be arranged in the position that results in the least stability, and the appliance is to be tipped 10 degrees in the direction most likely to overturn it. Legs or other means of support may be blocked to prevent the appliance from sliding during the test.

30.3 An appliance shall not overturn when a continuous downward force of 35 pounds (156 N) is applied at the point of maximum moment to any drawer or door that can be opened.

30.4 The appliance is to be placed on a horizontal surface, and set up for the test as described in 30.2. A force of 35 pounds (156 N) is to be applied vertically downward at the edge of any door or drawer open to the position providing the greatest lever arm.

### **31 Aerosol Containers and Deodorizers**

31.1 An aerosol container provided in or recommended for use in an appliance shall be located in the appliance so that it is not subject to heating.

31.2 An aerosol container is considered to comply with the requirements in 31.1 if the average temperature of the container does not exceed 8.9°C (16°F) above room ambient during the temperature test.

31.3 A deodorizer provided in or recommended for use in an appliance shall be of a type for which marking and labeling to conform to the Federal Hazardous Substances Act – Public Law (86-613) – is not required.

## **PERFORMANCE**

### **32 General**

32.1 Unless otherwise specified, all tests are to be conducted with the appliance connected to a source of supply of rated frequency and of maximum rated voltage except that the voltage is to be 120 volts for an appliance rated between 110 and 120 volts, and is to be 240 volts for an appliance rated between 220 and 240 volts.

### **33 Leakage Current Test**

33.1 The leakage current of a cord-connected appliance when tested in accordance with 33.3 – 33.7 shall not be more than:

- a) 0.5 milliampere for a portable appliance – see 2.4, and
- b) 0.75 milliampere for a stationary appliance.

33.2 Leakage current refers to all currents, including capacitively coupled currents, that may be conveyed between exposed conductive surfaces of an appliance and ground or other exposed conductive surfaces of an appliance.

33.3 All exposed conductive surfaces are to be tested for leakage currents. The leakage currents from these surfaces are to be measured to the grounded supply conductor individually as well as collectively where simultaneously accessible and from one surface to another where simultaneously accessible. Parts are considered to be exposed surfaces unless guarded by an enclosure that provides protection against a risk of electric shock as defined in Accessibility of Uninsulated Live Parts and Film-Coated Wire, Section 7. Surfaces are considered to be simultaneously accessible if they can be readily contacted by one or both hands of a person at the same time. These measurements do not apply to terminals operating at voltages that are considered not to present a risk of electric shock.

33.4 If a conductive surface other than metal is used for the enclosure or part of the enclosure, the leakage current is to be measured using metal foil having an area of 10 by 20 centimeters in contact with the surface. If the surface has an area less than 10 by 20 centimeters, the metal foil is to be the same size as the surface. The metal foil is not to remain in place long enough to affect the temperature of the appliance.

33.5 The measurement circuit for leakage current is to be as illustrated in Figure 33.1. The measurement instrument is defined in (a) – (c). The meter that is actually used for a measurement need only indicate the same numerical value for a particular measurement as would the defined instrument. The meter used need not have all the attributes of the defined instrument.

- a) The meter is to have an input impedance of 1500 ohms resistive shunted by a capacitance of 0.15 microfarad.
- b) The meter is to indicate 1.11 times the average of the full-wave rectified composite waveform of voltage across the resistor or current through the resistor.
- c) Over a frequency range of 0 – 100 kilohertz, the measurement circuitry is to have a frequency response – ratio of indicated to actual value of current – that is equal to the ratio of the impedance of a 1500-ohm resistor shunted by a 0.15-microfarad capacitor to 1500 ohms. At an indication of 0.5 or 0.75 milliamperes, the measurement is not to have an error of more than 5 percent at 60 hertz.

**Figure 33.1**  
**Leakage-current measurement circuit**

Figure 33.1 revised December 17, 1998

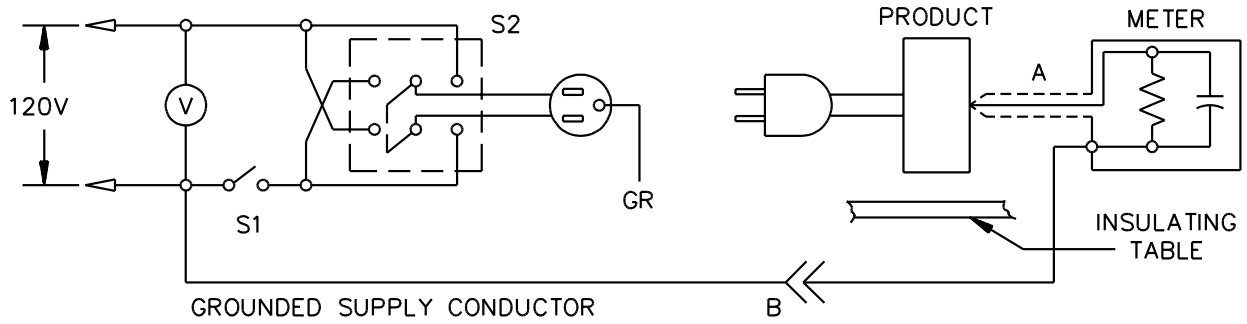

Product intended for connection to a 120-volt power supply, as illustrated above.

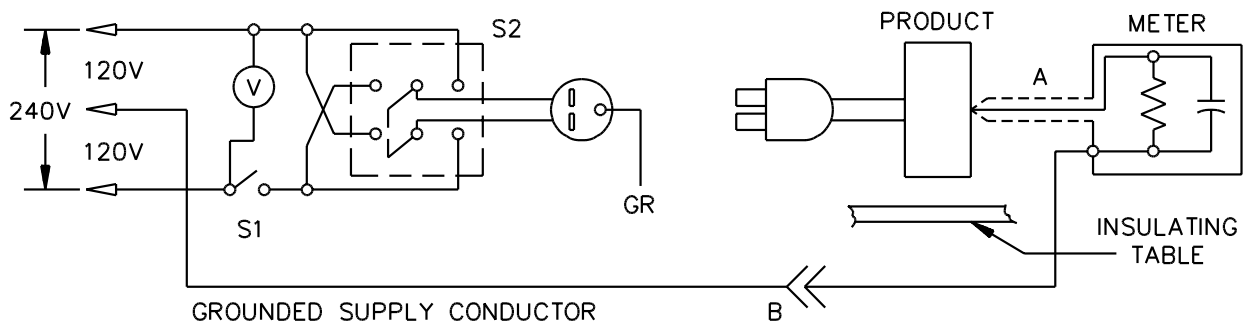

Product intended for connection to a 3-wire, grounded neutral power supply, as illustrated above.

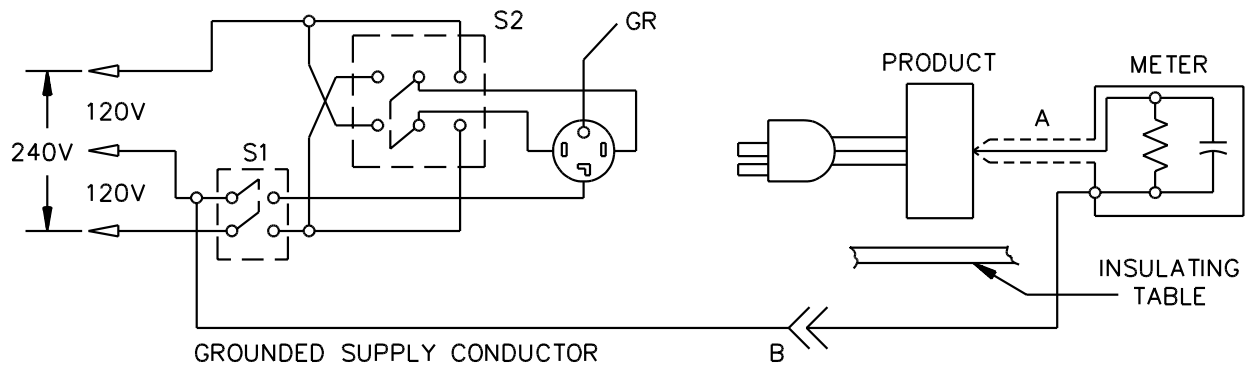

Product intended for connection to a 3-wire, grounded neutral power supply, as illustrated above.

LC300J

NOTES -

A: Probe with shielded lead.

B: Separated and used as clip when measuring currents from one part of product to another.

33.6 Unless the meter is being used to measure leakage from one part of an appliance to another, the meter is to be connected between the accessible parts and the grounded supply conductor.

33.7 A sample of the appliance is to be tested for leakage current starting with the as received condition – as received being without prior energization except as may occur as part of the production-line testing – but with the grounding conductor open at the attachment plug. The supply voltage is to be adjusted to the voltage specified in 32.1. The test sequence, with reference to the measuring circuit– Figure 33.1 – is to be as follows:

- a) With switch S1 open, the appliance is to be connected to the measuring circuit. Leakage current is to be measured using both positions of switch S2, and with the appliance switching devices in all their operating positions.
- b) Switch S1 is then to be closed energizing the appliance, and within 5 seconds, the leakage current is to be measured using both positions of switch S2, and with the appliance switching devices in all their operating positions.
- c) The leakage current is to be monitored until thermal stabilization. Both positions of switch S2 are to be used in determining this measurement. Thermal stabilization is to be obtained by operation as in the normal temperature test.

33.8 Normally the complete leakage current test program as described in 33.7, is to be conducted without interruption for other tests. With the concurrence of those concerned, the leakage current test may be interrupted for the purpose of conducting other nondestructive tests.

#### **34 Continuity Test of Grounding Circuit**

34.1 The resistance between the point of connection of the equipment-grounding means, at or within the appliance, and any point in the grounding circuit shall not be more than 0.1 ohm.

34.2 With reference to 34.1, the resistance may be determined by any convenient method. However, if unacceptable results are obtained, an alternating current of at least 20 amperes from a source of supply of not more than 12 volts is to be passed from the point of connection of the equipment-grounding means to the metal part in the grounding circuit, and the resulting drop in potential is to be measured between these two points. The resistance in ohms is to be determined by dividing the drop in potential in volts by the current in amperes passing between the two points. The grounding conductor of a power-supply cord is not to be included in this measurement.



### 35 Current Input Test

35.1 When connected to a circuit having rated frequency and the maximum rated voltage specified in 35.2 and operated as described in 37.2, the input to an appliance shall not be more than:

- a) For an appliance having a single current rating, 110 percent of the rated value.
- b) For an appliance having a dual current rating,
  - 1) Current input to the motor, 110 percent of the motor current rating, and
  - 2) Current input to the load other than the motor, 105 percent of the rating of that load.

No Text on This Page

35.2 For an appliance having a single voltage rating, such as 115 volts, maximum rated voltage is considered to be that single value of voltage. If the rating is specified in terms of a range of voltages, such as 110 – 120 volts, maximum rated voltage is considered to be the highest value of the range.

35.3 The requirement in 35.1 applies to the maximum current measured excluding the interval of time from 2 seconds before to 2 seconds after the reversal of the ram at the compacting end of the operational cycle.

### 36 Starting Current Test

36.1 An appliance other than as described in 36.2 shall start and operate as intended on a circuit protected by an ordinary – not a time-delay – fuse having a current rating corresponding to that of the branch circuit to which the appliance should be connected.

*Exception: The requirement does not apply if:*

- a) *The appliance will start and operate as intended on a circuit protected by a time-delay fuse, and*
- b) *The appliance is marked in accordance with 49.7.*

36.2 An appliance that would be connected to 15- or 20-ampere branch circuit shall start and operate as intended on a circuit protected by a time-delay fuse having an ampere rating corresponding to that of the branch circuit.

36.3 In a test to determine whether an appliance complies with the requirement in 36.1, it is to be started three times, with the appliance at room temperature at the beginning of the test. Each motor is to be started under conditions representing the normal operating cycle and load, and is to be allowed to come to full speed and then to come to rest between successive starts. Performance is unacceptable if the fuse opens, or an overload protector provided as part of the appliance trips.

### 37 Temperature Test

37.1 When tested as described in 37.2 – 37.11, an appliance shall not attain a temperature at any point sufficiently high to constitute a risk of fire, to adversely affect any materials employed in the appliance, or to exceed the temperature rises specified in Table 37.1.

37.2 The appliance is to be operated for six consecutive cycles with a 5-second interval between cycles, under each of the following load conditions and the motor be allowed to cool to room temperature before the next series of six operations:

- a) Without simulated trash load.
- b) With a simulated load of plastic foam blocks; or a load that would cause the ram to reverse direction within 1 inch (25.4 mm) of its maximum travel.

37.3 All values for temperature rises in Table 37.1 are based on an assumed ambient temperature of 25°C (77°F). However, tests may be conducted at any ambient temperature within the range of 20 – 40°C (68 – 104°F); or they may be conducted at an ambient temperature of 10 – 20°C (50 – 68°F) with the concurrence of those concerned.

37.4 If an appliance employs a component or circuit, such as a ready light, that can remain continuously energized, the component is to be operated until constant temperatures are attained.

37.5 A temperature is considered to be constant when three successive readings taken at intervals of 10 percent of the previously elapsed duration of the test, but not less than 5-minute intervals, indicate no change.

**Table 37.1**  
**Maximum acceptable temperature rises**

Materials and components		Degrees	
		C	F
1.	Varnished-cloth insulation	60	108
2.	Fuses	65	117
3.	Fiber employed as electrical insulation	65	117
4.	Wood or other combustible material, including the surfaces of the walls of the test alcove; and a surface upon which a permanently connected, convertible or a cord-connected undercounter appliance may be mounted in service; and surfaces that may be adjacent to the appliance when so mounted	65	117
5.	Any point within a terminal box or wiring compartment of a permanently connected appliance in which field-installed conductors are to be connected	35	63
6.	Class 105 (A) insulation systems on coil windings of an alternating-current motor having a diameter of more than 7 inches (178 mm), of a direct-current motor, and a universal motor <sup>a,b</sup> :		
	A. In an open motor:		
	Thermocouple method	65	117
	Resistance method	75	135
	B. In a totally enclosed motor:		
	Thermocouple method	70	126
	Resistance method	80	144
7.	Class 105 (A) insulation systems on coil windings of an alternating-current motor having a diameter of 7 inches (178 mm) or less, but not including a universal motor, and on a vibrator coil <sup>a,b</sup> :		
	A. In an open motor and on a vibrator coil:		
	Thermocouple or resistance method	75	135
	B. In a totally enclosed motor:		
	Thermocouple or resistance method	80	144

Table 37.1 Continued on Next Page

Table 37.1 Continued

Materials and components		Degrees	
		C	F
8.	Class 130 (B) insulation systems, except as specified in items 13 and 14 <sup>a</sup>		
	Thermocouple method	85	153
	Resistance method	105	189
9.	Phenolic composition employed as electrical insulation or as a part the deterioration which would result in a risk of fire or electric shock <sup>c</sup>	125	225
10.	Rubber- or thermoplastic-insulated wire and cord <sup>c,d,e</sup>	35	63
11.	Capacitor:		
	Electrolytic <sup>f</sup>	40	72
	Other types <sup>g</sup>	65	117
12.	Class 105 (A) insulation systems on windings of a relay, a solenoid, and the like <sup>a</sup> :		
	Thermocouple method	65	117
	Resistance method	85	153
13.	Class 130 (B) insulation systems on coil windings of an alternating-current motor having a frame diameter of more than 7 inches (178 mm), of a direct-current motor, and a universal motor <sup>a,b</sup> :		
	A. In an open motor:		
	Thermocouple method	85	153
	Resistance method	95	171
	B. In a totally enclosed motor:		
	Thermocouple method	90	162
	Resistance method	100	180
14.	Class B 130 (B) insulation systems on coil windings of an alternating-current motor having a diameter of 7 inches (178 mm) or less, but not including a universal motor <sup>a,b</sup> :		
	A. In an open motor:		
	Thermocouple or resistance method	95	171
	B. In a totally enclosed motor:		
	Thermocouple or resistance method	100	180
15.	Sealing compound <sup>h</sup>		

Table 37.1 Continued

Materials and components	Degrees																
	C	F															
<p><sup>a</sup> On the surface of an insulated coil where the temperature is affected by an external source of heat, the temperature rise measured by a thermocouple may be higher than the specified maximum, if the temperature rise of the coil, as measured by the resistance method, is not more than that specified in the table. The additional acceptable temperature rises above the values specified are:</p> <table border="1"> <thead> <tr> <th>Item</th> <th colspan="2">Temperature</th> </tr> </thead> <tbody> <tr> <td>Part A of items 6 and 7</td> <td>5°C</td> <td>(9°F)</td> </tr> <tr> <td>8</td> <td>20°C</td> <td>(36°F)</td> </tr> <tr> <td>12</td> <td>15°C</td> <td>(27°F)</td> </tr> <tr> <td>Part A of items 13 and 14</td> <td>10°C</td> <td>(18°F)</td> </tr> </tbody> </table>			Item	Temperature		Part A of items 6 and 7	5°C	(9°F)	8	20°C	(36°F)	12	15°C	(27°F)	Part A of items 13 and 14	10°C	(18°F)
Item	Temperature																
Part A of items 6 and 7	5°C	(9°F)															
8	20°C	(36°F)															
12	15°C	(27°F)															
Part A of items 13 and 14	10°C	(18°F)															
See 37.6.																	
<sup>b</sup> See note <sup>b</sup> to Table 22.2.																	
<sup>c</sup> The limitations on phenolic composition and on rubber and thermoplastic insulation do not apply to compounds that have been investigated and found to be acceptable for a higher temperature.																	
<sup>d</sup> Rubber-insulated conductors within a Class 105 (A) insulated motor and rubber-insulated motor leads, may be subjected to a temperature rise of more than 35°C (63°F), provided that an acceptable braid is employed on the conductors. However, this does not apply to thermoplastic-insulated wires or cords.																	
<sup>e</sup> A short length of rubber- or thermoplastic-insulated flexible cord exposed to a temperature of more than 60°C (140°F), such as at terminals, is acceptable if supplementary heat-resistant insulation of adequate dielectric strength is employed on the individual conductors of the cord to protect the appliance against deterioration of the conductor insulation.																	
<sup>f</sup> For an electrolytic capacitor that is physically integral with or attached to a motor, the temperature rise on insulating material integral with the capacitor enclosure may be not more than 65°C (117°F).																	
<sup>g</sup> A capacitor that operates at a temperature rise of more than 65°C (117°F) may be judged on the basis of its marked temperature limit.																	
<sup>h</sup> The maximum sealing compound temperature when corrected to a 25°C (77°F) ambient temperature, is 15°C (27°F) less than the softening point of the compound as determined by the Test Method for Softening Point by Ring-and-Ball Apparatus, ASTM E28-67(1982).																	

37.6 A thermocouple is to be used to determine the temperature of a coil or winding if it can be mounted, without removal of encapsulating compound or the like, on the integrally applied insulation of a coil without a wrap, or on the outer surface of a wrap that is not more than 1/32 inch (0.8 mm) thick and consists of cotton, paper, rayon, or the like, but not of asbestos or similar thermal insulation. The change-of-resistance method is to be used if the thermocouple measurement cannot be conducted in accordance with the foregoing considerations. For a thermocouple-measured temperature of a coil as mentioned in items 6, 7, 8, 12, 13, and 14 of Table 37.1, the thermocouple is to be mounted on the integrally applied insulation on the conductor.

37.7 In using the resistance method, the windings are to be at room temperature at the start of the test. The temperature rise of a winding is to be calculated from the formula:

$$\Delta t = \frac{R}{r} (k + t_1) - (k + t_2)$$

*in which:*

*$\Delta t$  is the temperature rise in °C;*

*$R$  is resistance of the coil at the end of the test in ohms;*

*$r$  is resistance of the coil at the beginning of the test in ohms;*

*$t_1$  is room temperature at the beginning of the test in °C;*

*$t_2$  is room temperature at the end of the test in °C; and*

*$k$  is 234.5 for copper, 225.0 for vertical conductor grade (EC) aluminum. Values of the constant  $k$  for other grades must be determined.*

37.8 Thermocouples are to consist of wires not larger than No. 24 AWG (0.21 mm<sup>2</sup>). However, it should be noted that when thermocouples are used in the determination of temperatures in connection with the heating of electrical devices, it is common practice to employ thermocouples consisting of No. 30 AWG (0.05 mm<sup>2</sup>) iron and constantan wires and a potentiometer-type indicating instrument; and such equipment is to be used whenever referee temperature measurements by thermocouples are necessary.

37.9 An appliance is to be mounted in an enclosure of nominal 3/8-inch thick, black-painted plywood, consisting of a bottom, a back, and two sides; the enclosure is to include a top for an undercounter, recessed or convertible appliance. Each of these areas is to be in as intimate contact with the corresponding surface of the appliance as the configuration of the latter permits. Temperatures are to be measured at points on each of these enclosing surfaces.

37.10 If the appliance incorporates a reel for the power-supply cord, one third of the length of the cord is to be unreeled for the temperature test.

37.11 A motor-protective device shall not operate during the normal temperature test.

### **38 Dielectric Voltage-Withstand Test**

38.1 An appliance shall withstand for 1 minute without breakdown the application of a 60-hertz essentially sinusoidal potential between live parts and dead metal parts, and between live parts of opposite polarity for a test on a capacitor used for radio-interference elimination or arc-suppression, with the appliance at the maximum operating temperature reached in normal use. The test potential shall be:

- a) One thousand volts for an appliance employing a motor rated 1/2 horsepower or less. See 16.4.
- b) One thousand volts plus twice rated voltage for an appliance employing a motor rated more than 1/2 horsepower. See 16.4.

38.2 If internal wiring or connections are subject to motion during normal use of the appliance – for example, a wire running from the stationary portion of the enclosure to the access door, or a brush-and-slip ring connection of a cord reel – the parts involved are to be moved through three or more cycles of operation while the test potential is being applied.

38.3 To determine if an appliance complies with the requirement in 38.1, the appliance is to be tested using a 500-volt-ampere or larger capacity transformer, the output voltage of which can be varied. The applied potential is to be increased from zero to the required test value, and is to be held at that value for 1 minute. The increase in potential is to be at a substantially uniform rate and as rapid as is consistent with correct indication of its value by a voltmeter.

## 39 Moisture Resistance Test

### 39.1 Humidity

39.1.1 A cord-connected appliance rated for a nominal 240 volts or less supply shall comply with the requirements for Leakage Current Test, Section 33, following conditioning for 48 hours in moist air having a relative humidity of  $88 \pm 2$  percent at a room temperature of  $32 \pm 2^\circ\text{C}$  ( $90 \pm 4^\circ\text{F}$ ).

- a) The appliance is to be at a temperature just above the test chamber temperature when it is placed in the humidity chamber.
- b) The appliance is to remain in the humidity chamber for 48 hours.
- c) Following this exposure, while still in the test chamber, the sample is to be tested unenergized as indicated in 33.5(a).
- d) The sample is then to be tested energized as indicated in 33.5 (b) and (c), except that the test may be discontinued when the leakage current has stabilized or decreased. This test may be conducted in the humidity chamber or immediately after the sample has been removed from the humidity chamber.

### 39.2 Water spillage

39.2.1 To determine whether a small quantity of liquid that may be placed in the waste receptacle or spilled or dripped onto the top, the front, the door, or the door assembly of an appliance will result in a risk of electric shock when the appliance is conditioned as described in 39.2.3:

- a) No obvious wetting that will adversely affect any electrical component shall be likely to occur during any conditioning, see 39.2.2; and
- b) The appliance:
  - 1) Shall comply with the dielectric voltage-withstand requirements in 38.1; and
  - 2) Shall, when evaluated using the method described in 33.3 – 33.6, not have a leakage current of more than 5.0 milliamperes.

39.2.2 Obvious wetting signifies wetting by a stream, spray, or dripping of water on the component that will be repeated during each test, but does not signify wetting by random drops of water that may wet the component by chance.



39.2.3 To determine whether an appliance complies with the requirements in 39.2.1, the appliance is to be installed in accordance with the manufacturer's instructions. The appliance is to be leveled and 200 cubic centimeters of water are to be poured into the area under consideration; or poured onto the appliance in such a manner that the water will run into the area under consideration. The water is to be poured from a height of 6 inches (152 mm), and within a 2-second interval. Both during and after conditioning, the appliance is to be tested for compliance with 39.2.1(b)(2), and after conditioning, it is to be tested for compliance with the remaining items of 39.2.1. If the location of two or more areas or openings is such that one spillage would normally reach both, it may not be necessary to subject each to a separate test.

*Exception: A rear-mounted console on the top of a portable appliance need not be subjected to the spillage test.*

## **40 Tests on Supply Cords**

### **40.1 Flexing**

40.1.1 An appliance in which intended operation of movable parts mechanically affects wiring or other insulated live parts, including a supply-cord reel, shall operate successfully in the intended manner for the number of cycles specified in 40.1.2 while connected to a supply circuit in accordance with 32.1. There shall be no electrical or mechanical breakdown of the appliance and, after the test, the appliance shall comply with the requirements for dielectric voltage-withstand in 38.1.

*Exception: If an interlock switch de-energizes the wiring or uninsulated live parts when flexed, the test may be conducted without energizing the sample.*

40.1.2 The number of cycles of flexing is to be:

- a) Fifty if flexing occurs only during installation or inspection of electrical field-wiring connections.
- b) Six thousand for a supply-cord reel or if flexing occurs only during regular prescribed servicing – such as lubrication, resetting of protectors, or the like.
- c) Thirty thousand if flexing occurs only during the compaction cycle – such as if a motor were mounted on a movable ram.
- d) One hundred thousand if flexing occurs during loading or unloading of the compacting compartment.

40.1.3 In a test to determine whether an appliance complies with the requirement in 40.1.1, any mechanical arrangement may be employed to operate the movable member at a rate of approximately 12 cycles per minute. The movable member, if other than a cord reel, is to be operated so that it will reach the actual limits of travel in both directions during each cycle.

40.1.4 To determine whether a supply-cord reel complies with the requirements in 40.1.1, the test is to be conducted with the supply cord not connected to the source of supply. Unreeling of the cord is to be arranged so that there will be a maximum tendency to abrade the cord insulation and wear parts in contact with the cord. The direction of tension on the cord during the test is to be in accordance with usage during normal service. Thirty inches (762 mm) or more of the cord are to be unreeled during the test and recoiled on the reel automatically. A latching mechanism may be disengaged to conduct the test.

## 40.2 Strain relief

40.2.1 The strain-relief means for a flexible cord shall withstand for 1 minute without displacement a direct pull of 35 pounds (156 N) applied to the cord, with the connections within the appliance disconnected.

40.2.2 A 35-pound (16-kilogram) weight is to be suspended from the cord and supported by the appliance so that the strain-relief means will be stressed from any angle that the construction of the appliance permits. The strain relief is not acceptable if, at the point of disconnection of the conductors, there is such movement of the cord as to indicate that stress would have resulted on the connections.

## 40.3 Push-back relief

40.3.1 To determine compliance with 11.1.1.12, a product shall be tested in accordance with 40.3.2 without occurrence of any of the conditions specified in 11.1.1.12 (a) – (d).

40.3.1 added December 17, 1998

40.3.2 The supply cord is to be held 1 inch (25.4 mm) from the point where the cord emerges from the product and is then to be pushed back into the product. The cord is to be pushed back into the product in 1-inch (25.4-mm) increments until the cord buckles or the force to push the cord into the product exceeds 6 lbf (26.7 N). The supply cord within the product is to be manipulated to determine compliance with 11.1.1.12.

40.3.2 added December 17, 1998

## 41 Overload Test on Switches

41.1 A switch or other device that controls a motor and has not been investigated and found to be acceptable for the purpose, shall perform acceptably when subjected to an overload test consisting of 50 cycles of operation, making and breaking the locked-rotor current of the motor. There shall be no electrical or mechanical breakdown of the device or undue pitting or burning of the contacts as a result of the overload test and the fuse in the grounding connection shall not open.

*Exception: A switch or other device interlocked so that it will not have to break the locked-rotor current of the motor.*

41.2 To determine whether a switch or other control device complies with the requirement in 41.1, the appliance is to be connected to a grounded supply circuit of rated frequency and voltage in accordance with 32.1, with the rotor of the motor locked in position. During the test, exposed dead metal parts of the appliance are to be connected to ground through a 3-ampere plug fuse and the connection is to be such that any single-pole, current-rupturing device is in an ungrounded conductor of the supply circuit. The device is to be operated at a rate of not more than 10 cycles per minute, except that a faster rate of operation may be employed with the concurrence of those concerned.

41.3 A switch or other device that controls a solenoid, a relay coil, or the like and has not been investigated and found to be acceptable for the purpose shall perform acceptably when subjected to an overload test consisting of 50 operations as described in 41.4. There shall be no electrical or mechanical breakdown of the device or undue burning or pitting of the contacts as a result of the overload test and the fuse in the grounding connection shall not open.

41.4 In a test to determine whether a switch or other control device complies with the requirement in 41.3, the appliance is to be connected to a supply circuit of rated frequency and 110 percent of maximum rated voltage. See 32.1. The load on the device under test is to be the same as that which it is intended to control in normal service. The device is to be operated at a rate of not more than 10 cycles per minute, except that a faster rate of operation may be employed with the concurrence of those concerned.

## 42 Tests on Liquid Containers

42.1 Where the deterioration of a liquid container seal, or similar component results in a risk of fire or injury to persons, the container seal, or similar component shall be resistant, as determined by investigation, to deterioration from the liquid intended to be in contact with the container seal.

42.1 revised December 1, 1999

42.2 To determine compliance with 42.1, the component shall be investigated with respect to the material of which the component is made, the size and shape of the component, the application in the appliance, and other factors. Where applicable, the investigation shall include visual inspection for cracks, deformation, and similar damage or deterioration after artificial aging, as well as comparison of hardness, tensile strength, and elongation before and after artificial aging.

42.2 revised December 1, 1999

42.3 With reference to 42.1 and 42.2, a component of rubber or neoprene, when tested to compare its tensile strength and elongation before and after artificial aging, complies when these properties are found to be not less than the minimum values specified in Table 42.1, corresponding to the temperature on the component during the Temperature Test, Section 37.

42.3 revised December 1, 1999

**Table 42.1**  
**Artificial-aging tests**

Table 42.1 revised December 1, 1999

Temperature on component during temperature test		Artificial aging procedure	Minimum percent of unaged value for samples	
Degrees			Tensile strength	Elongation
C	F			
60 or less	140 or less	Air oven aging for 70 hours at 100 ±2°C (212 ±3.6°F)	60	60
61–75	142–167	Air oven aging for 168 hours at 100 ±2°C (212 ±3.6°F)	50	50
76–90	169–194	Aged in air-circulating oven for 168 hours at 121.0 ±1.0°C (249.8 ±1.8°F)	50	50
91–105	196–221	Aged in air-circulating oven for 168 hours at 136.0 ±1.0°C (276.8 ±1.8°F)	50	50

## 43 Burnout Test on Components

### 43.1 General

43.1.1 With reference to 6.7, an unenclosed relay, a solenoid, or similar component, including a solenoid valve and a motor-starting relay, shall not emit flame or molten metal, other than solder, nor shall it result in glowing or flaming of the cheesecloth or tissue paper when tested as described in 43.1.2.

43.1.1 revised December 1, 1999

43.1.2 To determine whether a device complies with the requirement in 43.1.1, the device is to be supported on a soft wood surface covered with a double layer of white tissue paper, and is to be covered with a double layer of white cheesecloth. The device is to be energized as specified in 32.1. The test is to be continued for 7 hours unless burnout occurs sooner; or for a construction where the component is positively and reliably controlled by an automatic timer, protector, or similar device so that operation of the component is limited to a shorter interval, the test is to be terminated at the conclusion of such interval. The supply circuit is to include a fuse of the maximum current rating that is accommodated by the

fuseholder of the branch circuit to which the appliance normally be connected, but not less than 20 amperes. During the test, the plunger of a solenoid, solenoid valve, or a relay other than a motor-starting relay, is to be blocked in the normally open position. A motor-starting relay is to be operated with the contacts blocked in the normally open position or the closed position, whichever results in higher current through the relay coil; and the motor and other components of the appliance are to remain normally connected during the test.

43.1.2 revised December 1, 1999

## **43.2 Electrolytic capacitor**

43.2.1 To determine if an electrolytic capacitor as described in 18.1(d) is acceptable, several samples of the capacitor, mounted in the usual manner and with cotton placed around openings in the enclosure, are to be subjected to such overvoltage as to cause breakdown. If the cotton ignites upon breakdown of the capacitor, the results are not acceptable.

## **44 Leakage Test for Capacitors**

44.1 The total capacitance of capacitors connected from one or more ungrounded sides of the line to the frame or enclosure of a single-phase appliance of a type other than as described in 33.1, shall permit a total of not more than 5 milliamperes of leakage current from capacitive and other sources to flow to ground through a 1500-ohm resistor shunted by a 0.15 microfarad capacitor under normal operating conditions at rated voltage of the appliance.

## **45 Permanence of Marking Test**

45.1 A marking that is required to be permanent shall be molded, die-stamped, paint-stenciled, stamped or etched metal that is permanently secured, or indelibly stamped on a pressure sensitive label secured by adhesive that, upon investigation, is found to be acceptable for the application. Ordinary usage, handling, storage, and the like, of the appliance are considered in the determination of the permanence of the marking.

45.2 Unless it has been investigated and found to be acceptable for the application, a pressure sensitive label or a label that is secured by cement or adhesive and that is required to be permanent shall comply with the applicable requirements in the Standard for Marking and Labeling Systems, UL 969.

## MANUFACTURING AND PRODUCTION TESTS

### 46 Dielectric Voltage-Withstand Test

46.1 Each appliance shall withstand without electrical breakdown, as a routine production-line test, the application of a potential at a frequency within the range of 40 – 70 hertz, between the primary wiring, including connected components, and accessible dead metal parts that are likely to become energized, and between primary wiring and accessible low-voltage – 42.4 volts peak or less – metal parts, including terminals.

No Text on This Page

**Table 46.1**  
**Production-line test conditions**

Appliance rating	Condition A		Condition B	
	Potential, volts	Time, seconds	Potential, volts	Time, seconds
250 volts or less with or without a motor rated 1/2 horsepower	1000	60	1200	1
Rated more than 250 volts or with a motor rated more than 1/2 horsepower	$1000 + 2V^a$	60	$1200 + 2.4V^a$	1
<sup>a</sup> Maximum marked voltage but not less than 250 volts.				

46.2 The production-line test shall be in accordance with either condition A or condition B of Table 46.1.

46.3 The appliance may be in a heated or unheated condition for the test.

46.4 The test shall be conducted when the appliance is complete – fully assembled. It is not intended that the appliance be unwired, modified, or disassembled for the test.

*Exception No. 1: A part such as a snap cover or a friction-fit knob that would interfere with performance of the test need not be in place.*

*Exception No. 2: The test may be performed before final assembly if the test represents that for the completed appliance.*

46.5 If an appliance employs a solid-state component that is not relied upon to prevent a risk of electric shock and that can be damaged by the dielectric potential, the test may be conducted before the component is electrically connected, provided that a random sampling of each day's production is tested at the potential specified in Table 46.1. The circuitry may be rearranged for the purpose of the test to minimize the likelihood of solid-state-component damage while retaining representative dielectric stress of the circuit.

46.6 The test equipment shall include a transformer having an essentially sinusoidal adequate output, a means of indicating the test potential, an audible or visual indicator of electrical breakdown, and either a manually reset device to restore the equipment after electrical breakdown or an automatic reject feature of any unacceptable unit.

46.7 If the output of the test equipment transformer is less than 500 volt-amperes, the equipment shall include a voltmeter in the output circuit to directly indicate the test potential.

46.8 If the output of the test equipment transformer is 500 volt-amperes or larger, the test potential may be indicated:

- a) By a voltmeter in the primary circuit or in a tertiary-winding circuit,
- b) By a selector switch marked to indicate the test potential, or
- c) For equipment having a single test-potential output, by a marking in a readily visible location to indicate the test potential.

When marking is used without an indicating voltmeter, the equipment shall include a positive means, such as an indicator lamp, to indicate that the manually reset switch has been reset following a dielectric breakdown.

46.9 Test equipment, other than that described in 46.6 – 46.8 may be used if found to accomplish the intended factory control.

46.10 During the test, the primary switch is to be in the on position, both sides of the primary circuit of the appliance are to be connected together and to one terminal of the test equipment, and the second test-equipment terminal is to be connected to the accessible dead metal.

*Exception No. 1: An appliance – resistive, high-impedance winding, and the like – having circuitry not subject to excessive secondary-voltage build-up in case of electrical breakdown during the test may be tested with a single-pole primary switch, if used, in the off position, or with only one side of the primary circuit connected to the test equipment when the primary switch is in the on position, or when a primary switch is not used.*

*Exception No. 2: The primary switch is not required to be in the on position if the testing means applies full test potential between primary wiring and dead metal parts with the switch not in the on position.*

## **47 Grounding Continuity**

47.1 Each appliance that has a power-supply cord having a grounding conductor shall be tested, as a routine production-line test, to determine that continuity exists between the grounding blade of the attachment plug and the accessible dead metal parts of the appliance that are likely to become energized.

47.2 Only a single test need be conducted if the accessible metal selected is conductively connected to all other accessible metal.

47.3 Any indicating device – an ohmmeter, a battery-and-buzzer combination, or the like – may be used to determine compliance with the grounding continuity requirement in 47.1.

## **RATING**

### **48 General**

48.1 An appliance shall be rated in volts, and in frequency expressed in one of the following terms: hertz, Hz, cycles-per-second, cps, cycles/second, or c/s.

48.2 An appliance shall be rated in amperes.

*Exception: It may be rated in watts or kilowatts if the overall full-load power factor is 0.80 or more.*



48.3 If an appliance is marked with a horsepower (hp) rating, the rating shall not be less than the horsepower rating of the motor. If the appliance employs multiple motors or one or more motors and other loads, the horsepower rating of the appliance shall not be less than the equivalent of the hp rating of the combined loads. The total load shall be calculated in accordance with Section 422.62(A) of the National Electrical Code, ANSI/NFPA 70.

Added 48.3 effective January 6, 2005

## MARKING

### 49 General

49.1 An appliance shall be plainly and permanently marked, at a location where the marking will be readily visible – after installation in the case of an undercounter appliance – with:

- a) The manufacturer's name, trademark, or other descriptive marking by which the organization responsible for the product may be identified – hereinafter referred to as the manufacturer's name,
- b) The catalog number or the equivalent,
- c) The date of manufacture by week, month or quarter and year which may be abbreviated or in an established or otherwise acceptable code, and
- d) The electrical rating.

The number of phases shall be included in the marking if the appliance is intended for connection to a polyphase circuit. An appliance intended for connection to a 3-wire, single-phase circuit shall be marked "3-wire" or "3-W."

49.2 A required marking shall not be on a readily removable part.

49.3 An appliance shall be provided with a nonremovable schematic circuit diagram, secured to the back panel or at the location of the field-wiring terminals or leads or in any other location that is readily accessible to service personnel.

49.4 If an appliance can be readily adapted upon installation for connection to a supply circuit of either of two different voltages, complete instructions for making the connections for the different voltages, including appropriate identification of terminals, shall be included in the permanent marking on the appliance. If the appliance employs an attachment plug, instructions shall be provided to indicate the type of plug that should be used if the appliance is reconnected for the alternate voltage.

*Exception: The required information may be shown on a circuit diagram.*

49.5 If a manufacturer produces or assembles appliances at more than one factory, each finished appliance shall have a distinctive marking, which may be in code, by which it may be identified as the product of a particular factory.

49.6 An appliance, other than a cord-connected appliance, having one motor and other loads or more than one motor with or without other loads shall be marked:

- a) With the minimum supply circuit conductor ampacity to which the appliance is intended to be connected, and the maximum ampere rating of the overcurrent-protective device to be used in that circuit; or
- b) With the rating of the largest motor in volts and amperes, and the other loads in volts and amperes or volts and watts.

*Exception: The current value of a motor 1/8 horsepower or less, or a nonmotor load 1 ampere or less may be omitted unless such loads constitute the principal load.*

49.7 If an appliance will not start and attain normal running speed when connected to a circuit protected by an ordinary – not a time-delay – fuse as described in 36.1, the appliance shall be plainly and permanently marked with the words "Connect to a circuit protected by a \_\_\_\_ ampere time-delay fuse or circuit breaker," or with an equivalent wording.

49.8 An appliance that may be converted from cord-connected to permanently connected shall be provided with instructions for such conversion. The instructions may be packed inside the appliance.

49.9 An appliance that has plug-in provisions for the installation of an electrical accessory shall be plainly and permanently marked with the name and model number of the accessory. Instructions for installing the accessory shall be marked on the accessory or shall be included in literature supplied with the accessory.

49.10 A marking shall be provided on an appliance to inform the user of a risk of fire, electric shock, or injury to persons that is not obvious.

49.11 A cautionary marking shall be prefixed by the word "CAUTION," "WARNING," or "DANGER" in letters not less than 1/8 inch (3.2 mm) high. The remaining letters of such marking shall not be less than 1/16 inch (1.6 mm) high.

49.12 An appliance shall be marked in an area where it will be visible when loading the compacting compartment with the word "CAUTION" and the following or the equivalent: "Do not compact volatile or toxic materials as they may result in a risk of fire or injure your health."

49.13 All manual controls and switches shall be permanently and clearly marked with their function. The letters shall not be less than 3/32 inch (2.4 mm) high and shall contrast with their background.

49.14 A cautionary marking that is required to be permanent shall be located on a part that:

- a) Would require tools for removal, or
- b) Cannot be removed without impairing the operation of the compactor, or
- c) Would not be removed during normal servicing of the compactor.

49.15 A cautionary marking intended to instruct the operator shall be legible and visible to the operator during the normal operation of the appliance. A marking giving servicing instructions shall be legible and visible when such servicing is being performed.

49.16 A recessed or undercounter appliance shall be marked with the word "CAUTION" and the following or the equivalent: "This appliance is intended for undercounter (or recessed) installation."

49.17 An appliance provided with double insulation shall be permanently marked with the words "Double insulation – when servicing, use only identical replacement parts." The words "double-insulated" may be used instead of "double insulation."

49.18 An appliance may be marked with a double insulation symbol – a square within a square – the words "double insulation," or the equivalent, only if it complies with the applicable requirements in the Standard for Double Insulation Systems for Electrical Equipment, UL 1097.

49.19 An appliance having a part of an enclosure as described in the Exception to 27.3 shall be marked to indicate that such servicing is to be done with the appliance disconnected from the supply circuit.

No Text on This Page

## INSTRUCTION MANUAL

### 50 General

50.1 An appliance shall be provided with legible instructions pertaining to:

- a) The risk of fire, electric shock, or injury to persons that may be associated with its use,
- b) Operation and installation,
- c) User maintenance and storage; and as applicable,
- d) Grounding or double insulation.

50.2 The text of all required instructions shall be the words specified or words that are equivalent, clear, and understandable.

*Exception: If an appliance is such that the specified wording is unnecessary or conflicting, the wording may be omitted or modified, as appropriate.*

50.3 The instruction manual shall list any accessories that are recommended by the manufacturer or are mentioned in the instructions. Also see 49.9.

50.4 The manual shall indicate that the appliance is for household use. Also see 49.8.

### 51 Instructions Pertaining to a Risk of Fire, Electric Shock, or Injury to Persons

51.1 Instructions pertaining to a risk of fire, electric shock, or injury to persons shall warn the user of reasonably foreseeable risks and state precautions that should be taken to reduce such risks.

51.2 Instructions pertaining to a risk of fire, electric shock, or injury to persons shall be:

- a) In the first part of the manual,
- b) Before the operating instructions,
- c) Separate in format from other instructions related to assembly, operation, maintenance, and storage, and
- d) A permanent part of the manual.

51.3 The height of the lettering in the text and illustrations of the instructions specified in 51.5 shall be as follows:

- a) Upper case letters – not less than 5/64 inch (1.9 mm);
- b) Lower case letters – not less than 1/16 inch (1.6 mm);
- c) The statements, "IMPORTANT SAFETY INSTRUCTIONS" and "SAVE THESE INSTRUCTIONS," required by 51.4 – not less than 3/16 inch (4.8 mm).

51.4 The statement "IMPORTANT SAFETY INSTRUCTIONS" or the equivalent shall precede the list of instructions required by 51.5 and the statement "SAVE THESE INSTRUCTIONS" or the equivalent shall either precede or follow the list.

51.5 The instructions required by 51.1 shall include the items in the following list, as applicable, and any other instructions that the manufacturer deems necessary for the appliance. The statement "Read all instructions before using" shall precede the list of items as shown below. The items need not be numbered nor in the order presented.

### **IMPORTANT SAFETY INSTRUCTIONS**

When using an electrical appliance, basic precautions should always be followed, including the following:

Read all instructions before using (this appliance).

1. Close supervision is necessary when used by or near children. Do not allow to be used as a toy, or to run unattended at any time. Lock key switch when not in use and store key out of reach of children.
2. Do not touch moving parts.
3. Do not operate with a damaged cord set, plug, motor, or after damage in any manner. Have the appliance examined, repaired, or adjusted by an authorized serviceperson.
4. Do not compact toxic or volatile flammable material such as oily rags and insect sprays. Do not compact lighted cigarettes, cigars, or other hot or burning items. Do not overload your appliance.
5. Do not take apart this appliance. Incorrect reassembly can cause electric shock when subsequently used.
6. Use only for intended use as described in this manual. Do not use other than manufacturer's recommended attachments.
7. Handle a loaded trash bag with care. Sharp objects can pierce the bag and cause injury. Do not overload trash bag with heavy material such as glass.

### **SAVE THESE INSTRUCTIONS**

## 52 Grounding Instructions

52.1 The instruction manual for a grounded, cord-connected appliance shall include the following instructions or the equivalent. For an appliance for use on a nominal 120-volt supply circuit, the instructions shall include items (a) and (b) and the illustration in Figure 52.1. For an appliance for use on a nominal 240-volt supply circuit, the instructions shall include items (a) and (c).

### GROUNDING INSTRUCTIONS

- a) This appliance must be grounded while in use to reduce the risk of electric shock. The appliance is equipped with a three-conductor cord and three-prong grounding-type plug to fit the proper grounding-type receptacle. The green – or green and yellow – colored conductor in the cord is the grounding wire. Never connect the green – or green and yellow – wire to a live terminal.
- b) This appliance is for use on a nominal 120-volt circuit. It has a plug as shown in sketch A in Figure 52.1. The adapter shown in sketches B and C of Figure 52.1 is available for connecting a plug as shown in sketch A to a two-prong receptacle as shown in sketch B. The green-colored rigid tab, lug, or the like extending from the adapter must be connected to a permanent ground such as a properly grounded outlet box.
- c) This appliance is for use on a 240-volt circuit and is factory-equipped with a specific electric cord and grounding plug for connection to a properly grounded electric circuit. Make sure that the appliance is connected to an outlet having the same configuration as the plug. No adaptor should be used with this appliance.

52.1 revised December 17, 1998

### Figure 52.1 Grounding methods

Figure 52.1 revised December 17, 1998

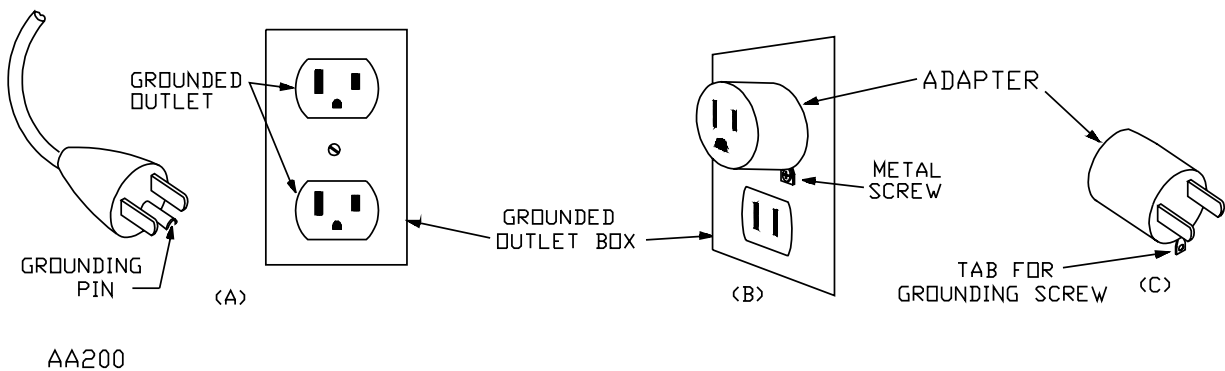

## 53 Use-Maintenance Instructions

53.1 The instruction manual for a cord-connected appliance shall also include the following:

- 1) Unplug the appliance from outlet before servicing.
- 2) Do not modify the plug attached to the compactor; use only with a grounded receptacle.

*Exception: The reference to use with a grounded receptacle is not required for a double-insulated appliance.*

53.2 The instruction manual shall include instructions for cleaning, user-maintenance, such as lubrication or nonlubrication, operations recommended by the manufacturer, and a statement to warn the user that any other servicing should be performed by an authorized service representative.

53.3 The instruction manual for a cord-connected appliance shall include specific instructions for the proper method of cord storage, appliance storage, and the like, when the appliance is not in use.

53.4 An appliance provided with a 2-blade polarized attachment plug shall be provided with the following instructions or the equivalent: To reduce the risk of electric shock, this appliance has a polarized plug (one blade is wider than the other). This plug will fit in a polarized outlet only one way. If the plug does not fit fully in the outlet, reverse the plug. If it still does not fit, contact a qualified electrician to install the proper outlet. Do not change the plug in any way.



## APPENDIX A

### Standards for Components

Standards under which components of the products covered by this standard are evaluated include the following:

Title of Standard – UL Standard Designation

---

Attachment Plugs and Receptacles – UL 498  
Cord Sets and Power-Supply Cords – UL 817  
Electric Motors – UL 1004  
Flexible Cord and Fixture Wire – UL 62  
General-Use Snap Switches – UL 20  
Polyvinyl Chloride, Polyethylene, and Rubber Insulating Tape – UL 510  
Marking and Labeling Systems – UL 969  
Polymeric Materials – Long Term Property Evaluations– UL 746B  
Polymeric Materials – Use in Electrical Equipment Evaluations – UL 746C  
Printed-Wiring Boards – UL 796  
Thermoset-Insulated Wires and Cables – UL 44  
Special-Use Switches – UL 1054  
Systems of Insulating Materials – General – UL 1446  
Temperature-Indicating and -Regulating Equipment – UL 873  
Thermal Cutoffs for Use in Electrical Appliances and Components– UL 1020  
Thermal Protectors for Motors – UL 547  
Thermoplastic-Insulated Wires and Cables – UL 83  
Wire Connectors – UL 486A-486B

No Text on This Page