

UL 1647

ISBN 0-7629-0153-5

# Motor-Operated Massage and Exercise Machines



Underwriters Laboratories Inc. (UL)  
333 Pfingsten Road  
Northbrook, IL 60062-2096

UL Standard for Safety for Motor-Operated Massage and Exercise Machines, UL 1647

Third Edition, Dated March 28, 1997

Revisions: This Standard contains revisions through and including January 24, 2001.

UL is in the process of converting its Standards for Safety to the Standard Generalized Markup Language (SGML), and implementing an SGML compliant document management and publishing system. SGML - an international standard (ISO 8879-1986) - is a descriptive markup language that describes a document's structure and purpose, rather than its physical appearance on a page. Significant benefits that will result from UL's use of SGML and these new systems include increased productivity, reduced turnaround times, and data and information consistency, reusability, shareability, and portability. However, the fonts, pagination, and general formatting of UL's new electronic publishing system differ from that of UL's previous publishing system. Consequently, when revision pages are issued for a Standard with the new publishing system, these differences may result in the printing of pages on which no requirements have been changed - these additional pages result from relocation of text due to repagination and reformatting of the Standard with the new publishing system.

The following table lists the future effective dates with the corresponding reference.

Future Effective Dates	References
April 15, 2001	4.3.1, 5.14.3, 10.1.2.3, 13A.1, 13A.2, 26.7, 45A.1 – 45A.4, 49E.1 – 49E.3

Text that has been changed in any manner is marked with a vertical line in the margin. Changes in requirements are marked with a vertical line in the margin and are followed by an effective date note indicating the date of publication or the date on which the changed requirement becomes effective.

The new and/or revised requirements are substantially in accordance with UL's Bulletin(s) on this subject dated November 22, 2000. The bulletin(s) is now obsolete and may be discarded.

The revisions dated January 24, 2001 include a reprinted title page (page1) for this Standard.

As indicated on the title page (page 1), this UL Standard for Safety is an American National Standard. Attention is directed to the note on the title page of this Standard outlining the procedures to be followed to retain the approved text of this ANSI/UL Standard.

The master for this Standard at UL's Northbrook Office is the official document insofar as it relates to a UL service and the compliance of a product with respect to the requirements for that product and service, or if there are questions regarding the accuracy of this Standard.

UL's Standards for Safety are copyrighted by UL. Neither a printed copy of a Standard, nor the distribution diskette for a Standard-on-Diskette and the file for the Standard on the distribution diskette should be altered in any way. All of UL's Standards and all copyrights, ownerships, and rights regarding those Standards shall remain the sole and exclusive property of UL.

All rights reserved. No part of this publication may be reproduced, stored in a retrieval system, or transmitted in any form by any means, electronic, mechanical photocopying, recording, or otherwise without prior permission of UL.

Revisions of UL Standards for Safety are issued from time to time. A UL Standard for Safety is current only if it incorporates the most recently adopted revisions.

UL provides this Standard "as is" without warranty of any kind, either expressed or implied, including but not limited to, the implied warranties of merchantability or fitness for any purpose.

In no event will UL be liable for any special, incidental, consequential, indirect or similar damages, including loss of profits, lost savings, loss of data, or any other damages arising out of the use of or the inability to use this Standard, even if UL or an authorized UL representative has been advised of the possibility of such damage. In no event shall UL's liability for any damage ever exceed the price paid for this Standard, regardless of the form of the claim.

UL will attempt to answer support requests concerning electronic versions of its Standards. However, this support service is offered on a reasonable efforts basis only, and UL may not be able to resolve every support request. UL supports the electronic versions of its Standards only if they are used under the conditions and operating systems for which it is intended. UL's support policies may change from time-to-time without notification.

UL reserves the right to change the format, presentation, file types and formats, delivery methods and formats, and the like of both its printed and electronic Standards without prior notice.

Purchasers of the electronic versions of UL's Standards for Safety agree to defend, indemnify, and hold UL harmless from and against any loss, expense, liability, damage, claim, or judgement (including reasonable attorney's fees) resulting from any error or deviation introduced while purchaser is storing an electronic Standard on the purchaser's computer system.

If a single-user version electronic Standard was purchased, one copy of this Standard may be stored on the hard disk of a single personal computer, or on a single LAN file-server or the permanent storage device of a multiple-user computer in such a manner that this Standard may only be accessed by one user at a time and for which there is no possibility of multiple concurrent access.

If a multiple-user version electronic Standard was purchased, one copy of the Standard may be stored on a single LAN file-server, or on the permanent storage device of a multiple-user computer, or on an Intranet server. The number of concurrent users shall not exceed the number of users authorized.

Electronic Standards are intended for on-line use, such as for viewing the requirements of a Standard, conducting a word search, and the like. Only one copy of the Standard may be printed from each single-user version of an electronic Standard. Only one copy of the Standard may be printed for each authorized user of a multiple-user version of an electronic Standard. Because of differences in the computer/software/printer setup used by UL and those of electronic Standards purchasers, the printed copy obtained by a purchaser may not look exactly like the on-line screen view or the printed Standard.

An employee of an organization purchasing a UL Standard can make a copy of the page or pages being viewed for their own fair and/or practical internal use.

The requirements in this Standard are now in effect, except for those paragraphs, sections, tables, figures, and/or other elements of the Standard having future effective dates as indicated in the note following the affected item. The prior text for requirements that have been revised and that have a future effective date are located after the Standard, and are preceded by a "SUPERSEDED REQUIREMENTS" notice.

New product submittals made prior to a specified future effective date will be judged under all of the requirements in this Standard including those requirements with a specified future effective date, unless the applicant specifically requests that the product be judged under the current requirements. However, if the applicant elects this option, it should be noted that compliance with all the requirements in this Standard will be required as a condition of continued Listing and Follow-Up Services after the effective date, and understanding of this should be signified in writing.

Copyright © 2001 Underwriters Laboratories Inc.

This Standard consists of pages dated as shown in the following checklist:

Page	Date
1 .....	January 24, 2001
2-2A .....	September 15, 2000
2B-3 .....	January 24, 2001
4 .....	March 28, 1997
5-6B .....	September 15, 2000
7-8B .....	January 24, 2001
9 .....	July 7, 1998
10 .....	October 15, 1999
10A .....	January 24, 2001
10B .....	October 15, 1999
11-15 .....	March 28, 1997
16 .....	September 15, 2000
17 .....	October 15, 1999
18-20 .....	March 28, 1997
21-24 .....	October 15, 1999
25-26 .....	March 28, 1997
27 .....	October 15, 1999
28 .....	July 7, 1998
29-31 .....	March 28, 1997
32-32B .....	October 15, 1999
33 .....	March 28, 1997
34-34B .....	January 24, 2001
35-36 .....	March 28, 1997
37-38 .....	October 15, 1999
39 .....	March 28, 1997
40 .....	July 7, 1998
41-42 .....	March 28, 1997
43-47 .....	October 15, 1999
48-51 .....	March 28, 1997
52-52B .....	October 15, 1999
53-54 .....	March 28, 1997
55-56D .....	October 15, 1999
56E-56F .....	January 24, 2001
57-58 .....	March 28, 1997
59 .....	October 15, 1999
60-68 .....	March 28, 1997
A1 .....	July 7, 1998
A2 .....	March 28, 1997
CRG1 .....	July 7, 1998
CRG2 .....	January 24, 2001
CRG3-CRG8 .....	July 7, 1998
CRG9-CRG10 .....	January 24, 2001
SR1-SR2 .....	January 24, 2001

**MARCH 28, 1997**  
(Title Page Reprinted: January 24, 2001)

1

**UL 1647**

**Standard for Motor-Operated Massage and Exercise Machines**

First Edition – March, 1983  
Second Edition – June, 1991

**Third Edition**

**March 28, 1997**

The most recent designation of ANSI/UL 1647 as an American National Standard (ANSI) occurred on July 13, 2000.

This ANSI/UL Standard for Safety is under periodic maintenance, whereby the ANSI approval is updated approximately every five years. The Third edition and revisions dated September 15, 2000 are ANSI approved; any subsequent revisions are not part of the ANSI designated text. To obtain a copy of the ANSI approved version of the Standard, contact *comm 2000* at [www.comm-2000.com](http://www.comm-2000.com).

An effective date included as a note immediately following certain requirements is one established by Underwriters Laboratories Inc.

Revisions of this Standard will be made by issuing revised or additional pages bearing their date of issue. A UL Standard is current only if it incorporates the most recently adopted revisions, all of which are itemized on the transmittal notice that accompanies the latest set of revised requirements.

**ISBN 0-7629-0153-5**

**COPYRIGHT © 1983, 2001 UNDERWRITERS LABORATORIES INC.**

No Text on This Page



**CONTENTS**

**FOREWORD** .....4

**INTRODUCTION**

1 Scope .....5  
 2 Glossary .....5  
 3 General .....6  
     3.1 Components .....6  
     3.2 Units of measurement .....6A  
     3.3 Undated references .....6A

**CONSTRUCTION**

4 General .....7  
 5 Frame and Enclosure .....7  
     5.14 Polymeric material enclosure .....10  
 6 Adhesives Used to Secure Parts .....10B  
 7 Mechanical Assembly .....10B  
 8 Protection Against Corrosion .....11  
 9 Accessibility of Uninsulated Live Parts and Film-Coated Wire .....11  
 10 Supply Connections .....15  
     10.1 Cord-connected appliances .....15  
     10.2 Permanently connected appliances .....19  
 11 Current-Carrying Parts .....21  
 12 Insulating Material .....21  
 13 Internal Wiring .....22  
     13.1 Mechanical protection .....22  
     13.2 Splices and connections .....23  
 13A Separation of Circuits .....23  
 14 Capacitors .....24  
 15 Grounding .....24  
     15.1 General .....24  
     15.2 Grounding identification .....26  
 16 Heating Elements .....26  
 17 Lampholders .....26  
 18 Motors .....27  
     18.1 Construction .....27  
     18.2 Overload protection .....27  
 19 Overload- or Thermal-Protective Devices .....28  
 20 Receptacles .....29  
 21 Switches and Controls .....29  
 22 Attachments .....30  
 23 Spacings .....30  
     23.11 Spacings to polymeric enclosures .....32

## PROTECTION AGAINST INJURY TO PERSONS

24	General	.32A
25	Sharp Edges	.33
26	Enclosures and Guards	.33
27	Materials	.34A
28	Rotating or Moving Members	.34A
29	Switches, Controls, and Interlocks	.35
30	Stability	.36
31	Markings	.37

## PERFORMANCE

32	General	.37
33	Leakage-Current Test	.38
34	Leakage Current Following Humidity Conditioning	.41
35	Starting-Current Test	.41
36	Input Test	.42
37	Temperature Test	.42
	37.1 General	.42
	37.2 Maximum normal load	.45
38	Surface Temperatures	.46
39	Surface-Temperature Test	.48
40	Dielectric Voltage-Withstand Test	.48
41	Resistance to Moisture Test	.49
42	Flooding of Live Parts Test	.50
43	Switch and Control Test	.50
44	Thermostat Test	.51
	44.1 General	.51
	44.2 Original calibration	.51
	44.3 Overload	.51
	44.4 Endurance	.51
	44.5 Recalibration	.52
45	Strain-Relief Test	.52
45A	Strain-Relief Clamp Test	.52
46	Flexing and Twisting Test	.52
	46.1 Flexing	.52
	46.2 Twisting	.53
47	Operational Test	.54
48	Abnormal-Operation Test	.55
49	Permanence of Marking Test	.55
49A	Polymeric Enclosure Tests	.56
	49A.1 Mold stress-relief distortion	.56
	49A.2 Impact	.56A
	49A.3 Drop impact	.56A
	49A.4 Ball impact	.56A
	49A.5 Stain-relief after mold stress-relief distortion	.56A
	49A.6 Abnormal operation	.56A
	49A.7 Crushing resistance	.56B
	49A.8 Thermal aging	.56B
49B	Polymeric Materials Used as Structural Support	.56C
49C	End-Product Arc Resistance	.56C
49D	Abnormal Overload	.56E

49E Shiatsu-Type Massager Entrapment Test .....56F

**MANUFACTURING AND PRODUCTION TESTS**

50 Dielectric Voltage-Withstand Test .....56F  
 51 Grounding-Continuity Test .....58

**RATING**

52 Details .....58

**MARKING**

53 Details .....59  
 53.1 General .....59  
 53.2 Permanently connected appliances .....60  
 53.3 Components .....61  
 53.4 Appliances with heating pads .....61

**INSTRUCTION MANUAL**

54 General .....62  
 55 Instructions Pertaining to a Risk of Fire, Electric Shock, or Injury to Persons .....62  
 56 Operating Instructions .....66  
 57 User-Maintenance Instructions .....66  
 58 Grounding/Double Insulation Instructions .....67

**APPENDIX A**

Standards for Components..... A1

**CANADIAN REQUIREMENTS COMPARISON GUIDE CRG 1647**

UL AND CANADIAN STANDARDS FOR MOTOR-OPERATED MESSAGE AND EXERCISE MACHINES .....CRG1

## FOREWORD

A. This Standard contains basic requirements for products covered by Underwriters Laboratories Inc. (UL) under its Follow-Up Service for this category within the limitations given below and in the Scope section of this Standard. These requirements are based upon sound engineering principles, research, records of tests and field experience, and an appreciation of the problems of manufacture, installation, and use derived from consultation with and information obtained from manufacturers, users, inspection authorities, and others having specialized experience. They are subject to revision as further experience and investigation may show is necessary or desirable.

B. The observance of the requirements of this Standard by a manufacturer is one of the conditions of the continued coverage of the manufacturer's product.

C. A product which complies with the text of this Standard will not necessarily be judged to comply with the Standard if, when examined and tested, it is found to have other features which impair the level of safety contemplated by these requirements.

D. A product employing materials or having forms of construction which conflict with specific requirements of the Standard cannot be judged to comply with the Standard. A product employing materials or having forms of construction not addressed by this Standard may be examined and tested according to the intent of the requirements and, if found to meet the intent of this Standard, may be judged to comply with the Standard.

E. UL, in performing its functions in accordance with its objectives, does not assume or undertake to discharge any responsibility of the manufacturer or any other party. The opinions and findings of UL represent its professional judgment given with due consideration to the necessary limitations of practical operation and state of the art at the time the Standard is processed. UL shall not be responsible to anyone for the use of or reliance upon this Standard by anyone. UL shall not incur any obligation or liability for damages, including consequential damages, arising out of or in connection with the use, interpretation of, or reliance upon this Standard.

F. Many tests required by the Standards of UL are inherently hazardous and adequate safeguards for personnel and property shall be employed in conducting such tests.

## INTRODUCTION

### 1 Scope

1.1 These requirements cover motor-operated massage and exercise machines, such as vibrators, exercise bicycles, vibrating and massaging chairs, and the like, are to be employed in accordance with the National Electrical Code, NFPA 70.

1.2 These requirements also cover massage and exercise machines such as vibrators in which motion of an operating part is produced by electrical means.

1.3 These requirements do not cover appliances rated more than 250 volts.

1.4 A product that contains features, characteristics, components, materials, or systems new or different from those covered by the requirements in this standard, and that involves a risk of fire or of electric shock or injury to persons shall be evaluated using appropriate additional component and end-product requirements to maintain the level of safety as originally anticipated by the intent of this standard. A product whose features, characteristics, components, materials, or systems conflict with specific requirements or provisions of this standard does not comply with this standard. Revision of requirements shall be proposed and adopted in conformance with the methods employed for development, revision, and implementation of this standard.

1.4 revised September 15, 2000

### 2 Glossary

2.1 For the purpose of this standard the following definitions apply.

2.2 AUTOMATICALLY CONTROLLED APPLIANCE – An appliance is considered to be automatically controlled if:

- a) The repeated starting of the appliance, beyond one complete predetermined cycle of operation to the point where some form of limit switch opens the circuit, is independent of any manual control;
- b) During any single predetermined cycle of operation, the motor is caused to stop and restart one or more times;
- c) Upon energizing the appliance, the initial starting of the motor may be intentionally delayed beyond normal, conventional starting; or
- d) During any single predetermined cycle of operation, automatic changing of the mechanical load may reduce the motor speed sufficiently to reestablish starting-winding connections to the supply circuit.

2.2A FIXED APPLIANCE – An appliance that is intended to be permanently connected electrically to the wiring system.

2.2A added October 15, 1999

2.3 LINE-VOLTAGE CIRCUIT – A circuit involving a potential of not more than 250 volts and having circuit characteristics in excess of those of a low-voltage circuit.

2.4 LOW-VOLTAGE CIRCUIT – A circuit involving a peak open-circuit potential of not more than 42.4 volts supplied by a primary battery, by a Class 2 transformer, or by a combination of a transformer and a fixed impedance that, as a unit, complies with all performance requirements for a Class 2 transformer. A circuit derived from a line-voltage circuit by connecting a resistance in series with the supply circuit as a means of limiting the voltage and current, is not considered to be a low-voltage circuit.

2.4A PORTABLE APPLIANCE – A cord connected appliance that is hand-held when used or easily conveyed by hand and weighs 40 lb (18.15 kg) or less.

2.4A added October 15, 1999

2.5 REMOTELY CONTROLLED APPLIANCE – An appliance that is out of sight of the operator who is at the starting device.

2.6 STATIONARY APPLIANCE – A cord connected appliance weighing more than 40 lb (18.15 kg).

2.6 added October 15, 1999

### 3 General

#### 3.1 Components

3.1.1 Except as indicated in 3.1.2, a component of a product covered by this standard shall comply with the requirements for that component. See Appendix A for a list of standards covering components generally used in the products covered by this standard.

3.1.2 A component is not required to comply with a specific requirement that:

- a) Involves a feature or characteristic not required in the application of the component in the product covered by this standard, or
- b) Is superseded by a requirement in this standard.

3.1.2 revised September 15, 2000

3.1.3 A component shall be used in accordance with its rating established for the intended conditions of use.

3.1.3 revised September 15, 2000

3.1.4 Specific components are incomplete in construction features or restricted in performance capabilities. Such components are intended for use only under limited conditions, such as certain temperatures not exceeding specified limits, and shall be used only under those specific conditions.

3.1.4 revised September 15, 2000

### **3.2 Units of measurement**

3.2.1 Values stated without parentheses are the requirement. Values in parentheses are explanatory or approximate information.

3.2.1 revised September 15, 2000

### **3.3 Undated references**

3.3.1 Any undated reference to a code or standard appearing in the requirements of this standard shall be interpreted as referring to the latest edition of that code or standard.

No Text on This Page



## CONSTRUCTION

### 4 General

4.1 An appliance shall employ materials that are acceptable for the application.

4.2 An appliance employing a heating element is judged on the basis of its compliance with the requirements in this standard insofar as they apply, and with the applicable requirements in the Standard for Electric Heating Appliances, UL 499.

4.3 Foam padding provided with an appliance having a heating pad shall comply with the requirements for HBF or better material.

4.3 revised January 24, 2001

4.3.1 Thermoplastic material used for a part of an appliance having any dimension (length, width, or height) greater than 12 inches (305 mm) shall be classified HB.

5.14.3 revised and relocated as 4.3.1 effective April 15, 2001

4.4 A heating pad employed in a massage or exercise machine shall comply with the applicable requirements in the Standard for Electric Heating Pads, UL 130.

*Exception: A heating pad that is not accessible and that complies with the requirements in the Resistance to Moisture Test, Section 41; Flexing and Twisting Test, Section 46; and Thermostat Test, Section 44, is acceptable.*

### 5 Frame and Enclosure

5.1 An appliance shall be formed and assembled so that it will have the strength and rigidity necessary to resist the abuses to which it is likely to be subjected, without resulting in a risk of fire, electric shock, or injury to persons due to total or partial collapse with resulting reduction of spacings, loosening or displacement of parts, or other serious defects.

5.2 For unreinforced, flat surfaces in general, cast metal shall not be less than 1/8 inch (3.2 mm) thick, except that malleable iron may be not less than 3/32 inch (2.4 mm) and die-cast metal may be not less than 5/64 inch (2.0 mm) thick. Corresponding thicknesses of not less than 3/32, 1/16 (1.6 mm), and 3/64 inch (1.2 mm), respectively, may be acceptable if the surface under consideration is curved, ribbed, or otherwise reinforced, or if the shape or size, or both, of the surface is such that the necessary mechanical strength is provided.

5.3 An enclosure of sheet metal shall be judged with respect to its size, shape, thickness of metal, and its application, considering the intended use of the complete appliance. Sheet steel having a thickness of less than 0.026 inch (0.66 mm) if uncoated or 0.029 inch (0.74 mm) if galvanized or of nonferrous sheet metal having a thickness of less than 0.036 inch (0.91 mm) shall not be used, except for relatively small areas or for surfaces that are curved or otherwise reinforced.

5.4 Sheet metal to which a wiring system is to be connected in the field shall have a thickness not less than 0.032 inch (0.81 mm) if uncoated steel, not less than 0.034 inch (0.86 mm) if galvanized steel, and not less than 0.045 inch (1.14 mm) if nonferrous.

5.5 Among the factors that shall be evaluated when determining the acceptability of magnesium or a nonmetallic material, other than a polymeric material, are resistance to:

- a) Mechanical damage,
- b) Impact,
- c) Moisture absorption,
- d) Combustion, and
- e) Distortion at temperatures to which the material is subjected under conditions of normal or abnormal use.

5.5 revised October 15, 1999

5.6 The enclosure of a remotely or automatically controlled appliance shall prevent molten metal, burning insulation, flaming particles, or the like, from falling on combustible materials, including the surface upon which the appliance is supported.

5.7 The requirement in 5.6 will necessitate that a switch, a relay, a solenoid, or the like, be individually and completely enclosed, except for terminals, unless it can be shown that malfunction of the component would not result in a risk of fire, or there are no openings in the bottom of the appliance enclosure. It will also necessitate the use of a barrier of noncombustible material:

- a) Under a motor unless:
  - 1) The structural parts of the motor or of the appliance provide the equivalent of such a barrier;
  - 2) The protection provided with the motor is such that no burning insulation or molten material falls to the surface that supports the appliance when the motor is energized under each of the following fault conditions:
    - i) Open main winding;
    - ii) Open starting winding;
    - iii) Starting switch short-circuited; and
    - iv) Capacitor of permanent-split capacitor motor short circuited – the short-circuit is to be applied before the motor is energized, and the rotor is to be locked;
  - 3) The motor is provided with a thermal motor protector – a protective device that is sensitive to temperature and current – that will prevent the temperature of the motor windings from exceeding 125°C (257°F) under the maximum load under which the motor will run without causing the protector to cycle and from exceeding 150°C (302°F) with the rotor of the motor locked; or
  - 4) The motor complies with the requirements in the Standard for Impedance-Protected Motors, UL 519, and the temperature of the motor winding will not exceed 150°C during the first 72 hours of operation with the rotor of the motor locked.

b) Under wiring, unless it is neoprene- or thermoplastic-insulated.

5.8 The barrier mentioned in 5.7 shall be horizontal, shall be located as illustrated in Figure 5.1, and shall not have an area less than that described in that illustration. Openings for drainage, ventilation, and the like, may be employed in the barrier, provided such openings would not permit molten metal, burning insulation, or the like, to fall on combustible material.

No Text on This Page

**Figure 5.1**  
**Location and extent of barrier**

Figure 5.1 revised July 7, 1998

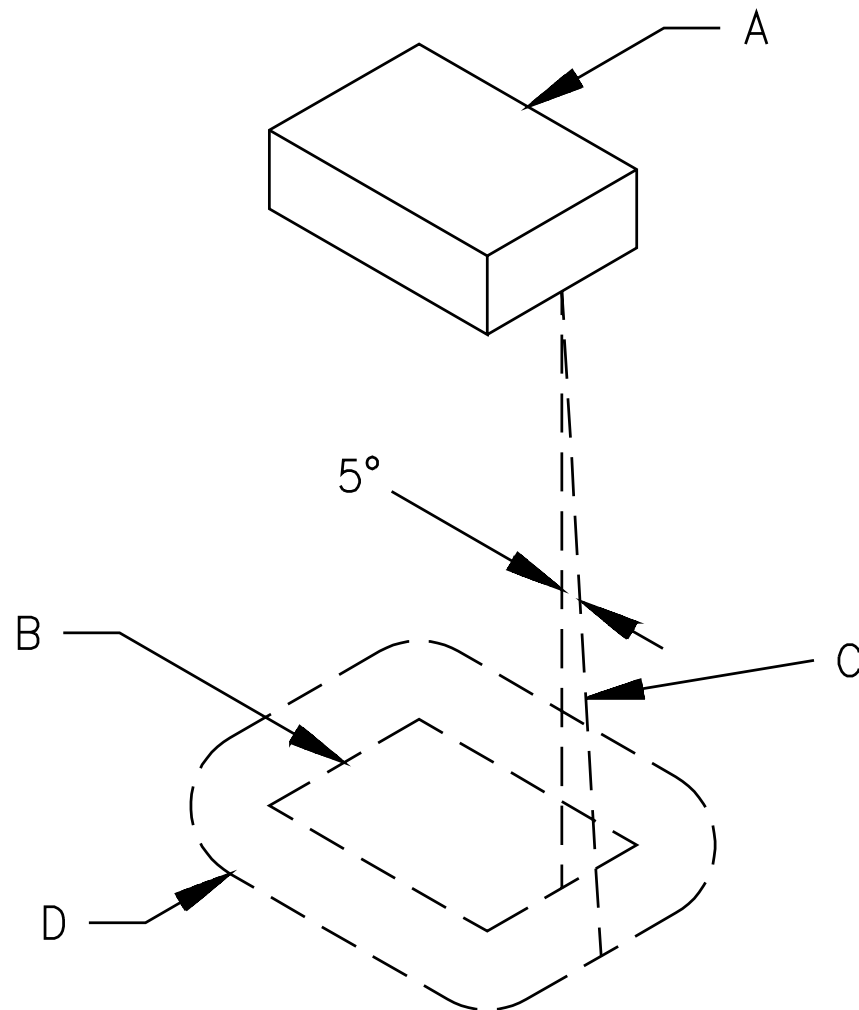

EB120A

A – Region to be shielded by barrier. This will consist of the entire component if it is not otherwise shielded and will consist of the unshielded portion of a component that is partially shielded by the component enclosure or equivalent.

B – Projection of outline of component on horizontal plane.

C – Inclined line that traces out minimum area of barrier. The line is always tangent to the component, 5 degrees from the vertical, and oriented so that the area traced out on a horizontal plane is maximum.

D – Location (horizontal) and minimum area for barrier. The area is that included inside the line of intersection traced out by the inclined line C and the horizontal plane of the barrier.

5.9 A door or a cover of an enclosure that provides access to any overload-protective device that requires resetting or renewal shall be hinged or otherwise attached in an equivalent manner.

5.10 Means shall be provided for holding the door or cover over a fuseholder in a closed position, and the door or cover shall be tight-fitting.

5.11 A cord-connected appliance that is provided with keyhole slots, notches, hanger holes, or the like, for hanging on a wall shall be constructed in such a manner that the hanging means is not accessible without removing the appliance from the supporting means.

5.12 To determine whether a product complies with the requirement in 5.11, any part of the enclosure or barrier that can be removed without the use of tools to gain access to the hanging means is to be removed.

5.13 An opening in the appliance provided for hanging shall be located or guarded so that a nail, hook, or the like does not displace a part that would create a risk of fire or electric shock and does not contact one of the following:

- a) An uninsulated live metal part.
- b) Magnet wire.
- c) Internal wiring.
- d) Moving parts.
- e) Any other part likely to create a risk of fire or electric shock.

#### **5.14 Polymeric material enclosure**

5.14.1 A polymeric material used to enclose uninsulated live parts, or enclose live parts having insulation less than 0.028 inch (0.71 mm) thick or equivalent, shall comply with Polymeric Enclosure Tests, Section 49A, and shall have a flammability class determined in accordance with the Standard for Tests for Flammability of Plastic Materials for Parts in Devices and Appliances, UL 94, as follows:

- a) Class 5VA for a fixed or stationary appliance or for an appliance that is permanently installed;

*Exception No. 1: A polymeric material classed HB minimum is capable of being used for a stationary appliance intended for household use, and that is cord connected, attended, and intermittent duty when it complies with all the following:*

- 1) All motors shall be provided with motor-overload protection complying with 18.2.2;*
- 2) Transformers shall comply with the Standards for Class 2 and Class 3 Transformers, UL 1585; Transformers and Motor Transformers for Use in Audio-, Radio-, and Television-Type Appliances, UL 1411; or Class 2 Power Units, UL 1310; and*
- 3) The appliance shall be provided with wheels or casters to facilitate movement from one location to another.*

*Exception No. 2: A polymeric material classed V-2 minimum is capable of being used for a stationary appliance intended for commercial use and that is cord connected, attended, and intermittent duty when it complies with all of the following:*

- 1) *All motors shall be provided with motor-overload protection complying with 18.2.2;*
  - 2) *Transformers shall comply with the Standards for Class 2 and Class 3 Transformers, UL 1585; Transformers and Motor Transformers for Use in Audio-, Radio-, and Television-Type Appliances, UL 1411; or Class 2 Power Units, UL 1310; and*
  - 3) *The appliance shall be provided with wheels or casters to facilitate movement from one location to another.*
- b) Class HB minimum for a portable, attended, intermittent duty, household appliance; or
- c) Class V-2 minimum for an appliance other than mentioned in (a) and (b).

5.14.1 added October 15, 1999

5.14.2 A polymeric material used to enclose insulated live parts having insulation 0.028 inch (0.71 mm) thick minimum or equivalent, internal wiring, or moving parts shall have a flammability class of HB minimum, and shall comply with Mold Stress-Relief Distortion, Section 49A.1, and Impact, Section 49A.2.

5.14.2 added October 15, 1999

*5.14.3 Revised and relocated as 4.3.1 effective April 15, 2001*

5.14.4 The volume resistivity of a polymeric material used in an enclosure as specified in 5.14.1, determined in accordance with the Standard for Polymeric Materials – Short Term Property Evaluations, UL 746A, shall not be less than:

- a) 50 megohm-centimeters after conditioning for 40 h at  $23 \pm 2^{\circ}\text{C}$  ( $73 \pm 4^{\circ}\text{F}$ ) and  $50 \pm 5$  percent relative humidity; and
- b) 10 megohm-centimeters after exposure for 96 hours to moist air having a relative humidity of  $90 \pm 5$  percent at a temperature of  $35 \pm 2^{\circ}\text{C}$  ( $95 \pm 4^{\circ}\text{F}$ ).

*Exception: A polymeric material having a volume resistivity lower than specified in (a) and (b) is capable of being used when the enclosure is determined to be a noncurrent-carrying metal part, and the product complies with Spacings, Section 23, and Spacings to Polymeric Enclosures, Section 23.11.*

5.14.4 added October 15, 1999

5.14.5 For a portable appliance, a polymeric material used to enclose uninsulated or insulated live parts shall have a hot wire ignition (HWI) performance level category (PLC) not greater than 4 – see Table 12.1 – as a result of the HWI test described in the Standard for Polymeric Materials – Short Term Property Evaluations, UL 746A.

*Exception: The material is not required to have a hot wire ignition rating when the live parts, including all internal wiring, are spaced 1/2 inch (12.7 mm) or more from the material.*

5.14.5 added October 15, 1999

5.14.6 For a stationary or fixed appliance, a polymeric material used to enclose uninsulated or insulated live parts shall have a hot wire ignition (HWI) performance level category (PLC) not greater than 3 – see Table 12.1 – as a result of the HWI test, described in the Standard for Polymeric Materials – Short Term Property Evaluations, UL 746A.

*Exception: The material is not required to have a hot wire ignition rating when the live parts, including all internal wiring, are spaced 1/2 inch (12.7 mm) or more from the material.*

5.14.6 added October 15, 1999

## **6 Adhesives Used to Secure Parts**

6.1 An adhesive that is relied upon to reduce a risk of electric shock, fire, or injury to persons shall comply with the requirements for adhesives in the Standard for Polymeric Materials – Use in Electrical Equipment Evaluations, UL 746C.

6.2 The requirement in 6.1 also applies to an adhesive used to secure a conductive part, including a nameplate, that may, if loosened or dislodged:

- a) Energize an accessible dead metal part,
- b) Make a live part accessible,
- c) Reduce spacings below the minimum acceptable values, or
- d) Short-circuit live parts.

## **7 Mechanical Assembly**

7.1 An appliance shall be assembled so that it will not be adversely affected by the vibration of intended operation. Brush caps shall be tightly threaded or otherwise constructed to prevent loosening.

7.2 A switch other than a through-cord switch, a lampholder, a plug adapter, a motor-attachment plug, or similar component shall be mounted securely and shall be prevented from turning. See 7.4.

*Exception No. 1: A switch need not be prevented from turning if all four of the following conditions are met:*

- a) The switch is of a plunger or other type that does not tend to rotate when operated. A toggle switch is considered to be subject to forces that tend to turn the switch during intended operation of the switch.*



- b) *The means for mounting the switch makes it unlikely that operation of the switch will loosen it.*
- c) *The spacings are not reduced below the minimum required values if the switch rotates.*
- d) *The intended operation of the switch is by mechanical means rather than by direct contact by persons.*

*Exception No. 2: A lampholder of the type in which the lamp cannot be replaced, such as a neon pilot or indicator light in which the lamp is sealed in a nonremovable jewel, need not be prevented from turning if rotation cannot reduce spacings below the minimum required values.*

7.3 Uninsulated live parts shall be secured to the base or mounting surface so that they will be prevented from turning or shifting in position, if such motion may result in a reduction of spacings below the minimum acceptable values.

7.4 The means for preventing the turning or shifting mentioned in 7.2 and 7.3 is to consist of more than friction between surfaces – for example, a properly applied lock washer, is acceptable as the means for preventing a small stem-mounted switch or other device having a single-hole mounting means, from turning.

## **8 Protection Against Corrosion**

8.1 Iron and steel parts shall be protected against corrosion by enameling, galvanizing, plating, or other equivalent means, if corrosion of such unprotected parts would be likely to result in a risk of fire, electric shock, or injury to persons.

*Exception No. 1: Surfaces of sheet-steel and cast-iron parts within an enclosure may not be required to be protected against corrosion if the oxidation of the metal due to the exposure to air and moisture is not likely to be appreciable. The thickness of metal and temperature are also to be considered.*

*Exception No. 2: This requirement does not apply to bearings, laminations, or minor parts of iron or steel, such as washers, screws, and the like.*

8.2 If deterioration of a liquid container provided as a part of an appliance would result in a risk of fire or electric shock, the container shall be of a material that is resistant to corrosion by the liquid intended to be used therein.

## **9 Accessibility of Uninsulated Live Parts and Film-Coated Wire**

9.1 To reduce the likelihood of unintentional contact that may involve a risk of electric shock from an uninsulated live part or film-coated wire, an opening in an enclosure shall comply with either (a) or (b).

- a) For an opening that has a minor dimension (see 9.3) less than 1 inch (25.4 mm), such a part or wire shall not be contacted by the probe illustrated in Figure 9.1.
- b) For an opening that has a minor dimension of 1 inch or more, such a part or wire shall be spaced from the opening as specified in 9.5 and Figure 9.2.

9.2 The probe mentioned in 9.1 and illustrated in Figure 9.1 shall be applied to any depth that the opening will permit; and shall be rotated or angled before, during, and after insertion through the opening to any position that is necessary to examine the enclosure. The probe shall be applied in any possible configuration; and, if necessary, the configuration shall be changed after insertion through the opening.

9.3 With reference to the requirements in 9.1, the minor dimension of an opening is the diameter of the largest cylindrical probe having a hemispherical tip that can be inserted through the opening.

9.4 During the examination of an appliance to determine whether it complies with the requirements in 9.1, a part of the enclosure that may be opened or removed by the user without using a tool (to attach an accessory, to make an operating adjustment, or for other reasons) is to be opened or removed.

9.5 An opening as specified in 9.1 (b) and illustrated in Figure 9.2 is acceptable if, within the enclosure, there is no uninsulated live part or film-coated wire:

- a) Less than X distance from the perimeter of the opening, as well as
- b) Within the volume generated by five times the diameter of the largest round rod that can be inserted through the opening, but not less than 4 inches (102 mm).

In evaluating an opening, any barrier located within the volume usually is ignored unless it intersects the boundaries of the volume in a continuous, closed line.

Figure 9.1  
Articulate probe with web stop

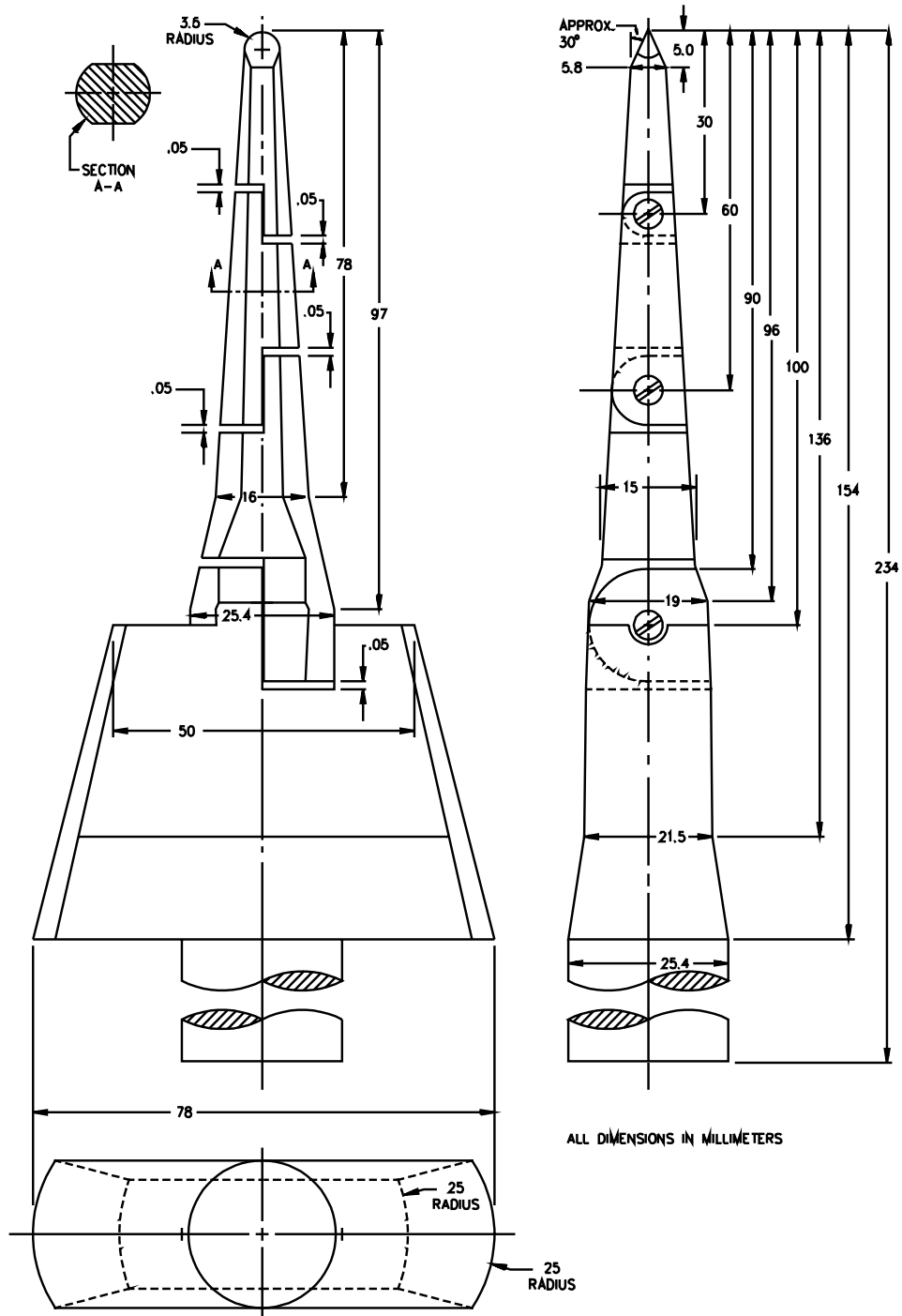

PA100A

Figure 9.2  
Opening in enclosure

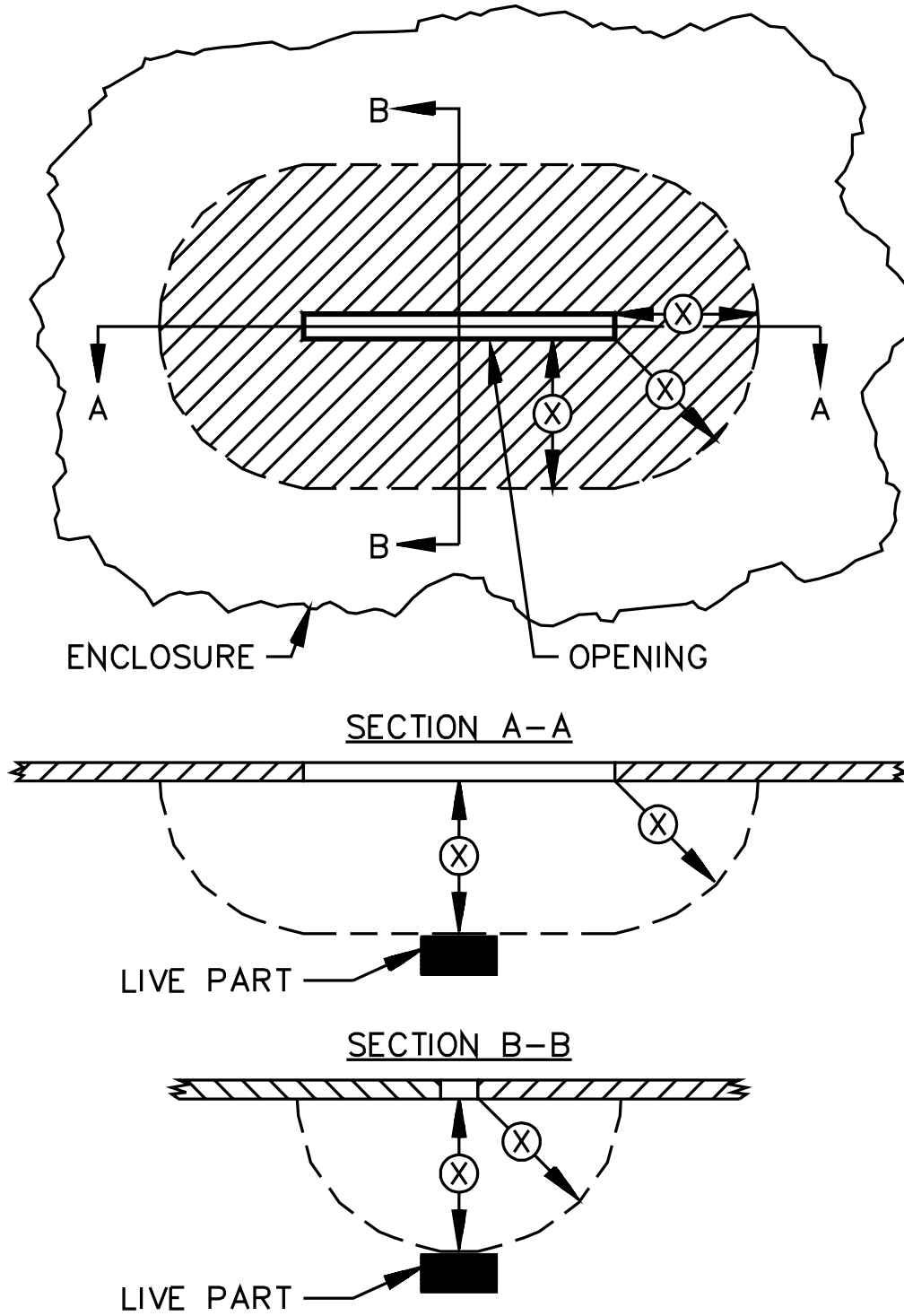

EC100A

## 10 Supply Connections

### 10.1 Cord-connected appliances

#### 10.1.1 Cords and plugs

10.1.1.1 An appliance intended to be connected to the power-supply circuit by means of a flexible cord shall be provided with a flexible cord and an attachment plug for connection to the supply circuit.

10.1.1.2 The attachment plug of an appliance intended to be connected to a nominal 120 volt circuit, and employing devices required to be connected to a specific supply conductor as specified in 17.1, 20.1, and 21.6 shall be a polarized type. The connections to the attachment plug shall be in accordance with Figure 10.1. The polarity identification of the supply cord shall be in accordance with Table 10.1. See 56.3.

**Table 10.1**  
**Polarity identification of flexible cords**

Method of identification	Acceptable combinations	
	Wire intended to be grounded <sup>a,b</sup>	All other wires <sup>a</sup>
Color of braid on individual conductors	Solid white or natural gray – without tracer	Solid color other than white or natural gray – without tracer
	Color other than white or natural gray, with tracer in braid	Solid color other than white or natural gray – without tracer
Color of insulation on individual conductors	Solid white or natural gray <sup>c</sup>	Solid color other than white or natural gray
	Light blue <sup>d</sup>	Solid color other than light blue, white, or natural gray
Other means	Tin or other white metal on all strands of the conductor <sup>e</sup>	No tin or other white metal on the strands of the conductor
	A stripe, ridge or groove on the exterior surface of the cord <sup>f</sup>	
<sup>a</sup> A wire finished to show a green color with or without one or more yellow stripes or tracers is to be used only as an equipment-grounding conductor. See 15.2.1 and Figure 10.1. <sup>b</sup> The grounded (identified) conductor is the neutral supply conductor. <sup>c</sup> Only for cords – other than Types SP-1, SP-2, SPE-1, SPE-2, SPT-1, and SPT-2, – having no braid on any individual conductor. <sup>d</sup> For jacketed cords. <sup>e</sup> Only for Types SPT-1 and SPT-2 cords. <sup>f</sup> Only for Types SP-1, SP-2, SPE-1, SPE-2, SPT-1, and SPT-2 cords.		

**Figure 10.1**  
**Connections to attachment plugs**

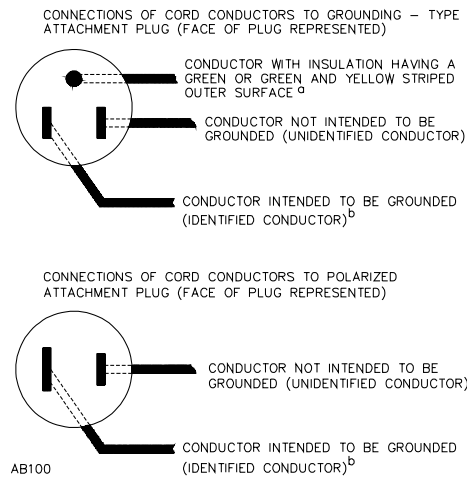

<sup>a</sup> In the above illustration, the blade to which the green conductor is connected may have a U-shape instead of a circular cross section.

<sup>b</sup> Signifies a conductor identified in accordance with Table 10.1. The grounded (identified) conductor is the neutral supply conductor.

10.1.1.3 An appliance that is required to employ a polarized attachment plug as specified in 10.1.1.2, and that is provided with a separate or detachable cord set as specified in the exception to 10.1.1.6 and 10.1.1.8 shall also employ an appliance connector of the polarized type.

10.1.1.4 The ampacity of the cord and the current rating of the attachment plug shall not be less than the maximum normal load current of the appliance. The voltage rating of the cord shall not be less than that of the appliance. The voltage rating of the attachment plug shall be equal to that of the appliance.

10.1.1.5 The flexible cord shall be as specified in Table 10.2, or shall be of a type at least equally serviceable for the application.

10.1.1.6 The flexible cord shall not be less than 6 feet (1.83 m) long and shall be attached to the appliance.

*Exception: An appliance that is not required to be provided with a grounding conductor may be provided with a separate cord-set having means for connection to the appliance and a length of not less than 6 feet.*

**Table 10.2**  
**Cords for appliances**

Appliance type	Cord type
Household use other than noted below	SP-2, SPE-2, or SPT-2
Commercial use other than noted below	SJ, SJE, or SJT
Hand held weighing 1 pound (454 g) or less	TP, TPT
Hand held, household use, weighing more than 1 pound (454 g)	SP-1, SPE-1, or SPT-1
Hand held, commercial use, weighing more than 1 pound (454 g)	SP-2, SPE-2, or SPT-2
Chair, tables, and the like	SJ, SJE, or SJT
Commercial use, footstool or cushion type	SV, SVE, SVO, SVOO, SVT, SVTO, or SVTOO

10.1.1.7 The length of an attached flexible cord includes the attachment plug. The length of a cord-set includes the fittings.

10.1.1.8 A household appliance intended for use with a detachable cord-set shall not be provided with terminal pins that will accommodate a standard flatiron or appliance plug.

10.1.1.9 If an appliance can be adapted for use on two or more different values of voltage by field alteration of internal connections, the attachment plug provided with the appliance shall be acceptable for the voltage for which the appliance is connected when shipped from the factory. See 53.1.3.

#### 10.1.2 Strain relief

10.1.2.1 Strain relief shall be provided so that mechanical stress on a flexible cord will not be transmitted to terminals, splices, or interior wiring.

10.1.2.2 A metal strain-relief clamp or band used with Type SP-2, SPE-2 or lighter general-use rubber-insulated cord shall be provided with auxiliary insulation over the cord for mechanical protection.

*Exception: The auxiliary insulation may be omitted for Type SV, SVE, SVO, or SVOO cord.*

10.1.2.3 A clamp of any material – metal or otherwise – shall not be used on Type SPT-1, SVT, SVTO, SVTOO, SPT-2, TP, or TPT cord or on cords of similar or lighter construction.

*Exception No. 1: A clamp is capable of being used on Type SPT-1, SVT, SVTO, SVTOO, SPT-2, TP, or TPT (or similar) cord protected by varnished cloth tubing, phenolic, vulcanized rubber, or the equivalent under the cord grip, when the construction complies with Strain-Relief Clamp Test, Section 45A. Thermoplastic tubing shall not be used over thermoplastic cords.*

*Exception No. 2: This requirement does not apply to a clamp that is rated for strain relief for the cord type used in the application.*

Revised 10.1.2.3 effective April 15, 2001

10.1.2.4 For types of thermoplastic-insulated cord, heavier than Type SPT-1, SPT-2, SVT, SVTO, or SVTOO, a clamp may be employed and the auxiliary insulation is not required unless it is judged that the clamp may damage the cord insulation.

10.1.2.5 Means shall be provided to prevent a flexible cord from being pushed into an appliance through a cord-entry hole if such displacement may subject the cord to mechanical damage or to exposure to a temperature higher than that for which the cord is acceptable, or may reduce a spacing, such as to a metal strain-relief clamp, below the minimum acceptable value.

10.1.2.6 If a knot in a flexible cord serves as strain relief, a surface that the knot may contact shall be free from projections, sharp edges, burrs, fins, and the like, that may cause abrasion of the insulation on the conductors.

### 10.1.3 Bushings

10.1.3.1 At a point where a flexible cord passes through an opening in a wall, barrier, or enclosing case, there shall be a bushing or the equivalent that shall be reliably secured in place, and shall have a smooth, rounded surface against which the cord may bear.

10.1.3.2 An insulating bushing shall be provided if:

- a) Type SP-1, SPE-1, SPT-1, SP-2, SPE-2, SPT-2, or other cord lighter than Type SV or SVE is employed,
- b) The wall or barrier is of metal, or
- c) The construction is such that the cord may be subjected to strain or motion.

*Exception: An insulated metal grommet having insulating material that is not less than 1/32 inch (0.8 mm) thick and fills completely the space between the grommet and the metal in which it is mounted may be used instead of an insulating bushing.*

10.1.3.3 A cord hole in wood, porcelain, phenolic composition, or other nonconducting material and having a smooth, rounded surface is considered to be equivalent to a bushing.

10.1.3.4 Ceramic materials and some molded compositions are acceptable for insulating bushings.

10.1.3.5 A separate bushing shall not be made of wood or of hot-molded shellac-and-tar compositions.

10.1.3.6 A vulcanized fiber bushing shall not be less than 3/16 inch (4.8 mm) thick and shall be formed and secured in place so that it will not be adversely affected by conditions of ordinary moisture.

10.1.3.7 A separate soft-rubber, neoprene, or polyvinyl chloride bushing shall not be employed in the appliance.

*Exception No. 1: A separate soft-rubber, neoprene, or polyvinyl chloride bushing may be employed in the frame of a motor or in the enclosure of a capacitor attached to a motor provided that:*

- a) *The bushing is not less than 3/64 inch (1.2 mm) thick; and*
- b) *The bushing is located so that it will not be exposed to oil, grease, oily vapor, or other substances having a deleterious effect on the compound employed.*



*Exception No. 2: A bushing of any of the materials mentioned in 10.1.3.7 may be employed at any point in an appliance if used in conjunction with a type of cord for which an insulating bushing is not required. If a bushing of one of these materials is used anywhere in the appliance, the edges of the hole in which the bushing is mounted are to be smooth and free from burrs, fins, and the like.*

10.1.3.8 At any point in an appliance, a bushing of the same material as, and molded integrally with, the supply cord is acceptable on a Type SP-1 or heavier cord if the built-up section is not less than 1/16 inch (1.6 mm) thick at the point where the cord passes through the enclosure.

## **10.2 Permanently connected appliances**

### 10.2.1 General

10.2.1.1 Except as noted in 10.2.1.2, an appliance intended for permanent connection to the power supply shall have provision for connection of one of the wiring systems that would be acceptable for the appliance.

10.2.1.2 A stationary appliance may be acceptable if provided with not more than 8 feet (2.44 m) of Type S, SE, SO, SOO, ST, STO, or STOO cord and an attachment plug for supply connection. The investigation of such a feature will include consideration of the utility of the appliance and the necessity of having it readily detachable from its source of supply by means of a plug.

### 10.2.2 Terminal compartment

10.2.2.1 A terminal box or compartment in which power-supply connections to a permanently connected appliance are to be made shall be located so that the connections may be readily inspected after the appliance is installed as intended.

10.2.2.2 A terminal compartment intended for connection of a supply raceway shall be attached to the appliance so as to be prevented from turning.

10.2.2.3 The terminal compartment on a motor that is intended to be connected directly to the supply shall comply with the requirements for terminal compartments in the Standard for Electric Motors, UL 1004.

### 10.2.3 Wiring terminals and leads

10.2.3.1 A permanently connected appliance shall be provided with wiring terminals for the connection of conductors having an ampacity acceptable for the appliance; or the appliance shall be provided with leads for such connection.

10.2.3.2 A field-wiring terminal is considered to be a terminal to which a wire may be connected in the field, unless the wire and a means of making the connection – a pressure terminal connector, soldering lug, soldered loop, crimped eyelet, and the like – factory-assembled to the wire, are provided as a part of the appliance.

10.2.3.3 Wiring terminals for the supply conductors – excluding the grounding conductor – shall be provided with a pressure wire connector securely fastened in place; for example, firmly bolted or held by a screw.

*Exception No. 1: A soldering lug may be used.*

*Exception No. 2: A wire binding screw may be employed at a wiring terminal intended to accommodate a No. 10 AWG (5.3 mm<sup>2</sup>) or smaller conductor if upturned lugs or the equivalent are provided to hold the wire in place.*

10.2.3.4 A wiring terminal shall be prevented from turning.

10.2.3.5 The free length of a lead inside an outlet box or wiring compartment shall be 6 inches (152 mm) or more if the lead is intended for field connection to an external circuit.

*Exception: The lead may be less than 6 inches long if it is evident that the use of a longer lead may result in a risk of fire or electric shock.*

10.2.3.6 A wire-binding screw at a wiring terminal shall not be smaller than No. 10.

*Exception No. 1: A No. 8 screw may be used at a terminal intended only for the connection of a No. 14 AWG (2.1 mm<sup>2</sup>) conductor.*

*Exception No. 2: A No. 6 screw may be used for the connection of a No. 16 or 18 AWG (1.3 or 0.8 mm<sup>2</sup>) conductor. See 10.2.3.7.*

10.2.3.7 According to the National Electrical Code, ANSI/NFPA 70-1996, No. 14 AWG (2.1 mm<sup>2</sup>) is the smallest conductor that may be used for branch-circuit wiring, and therefore is the smallest conductor that may be anticipated at a terminal for connection of a power-supply wire.

10.2.3.8 A wire-binding screw shall thread into metal.

10.2.3.9 A terminal plate tapped for a wire-binding screw shall be of metal not less than 0.050 inch (1.27 mm) thick and shall not have less than two full threads in the metal.

*Exception: An alloy plate may be not less than 0.030 inch (0.76 mm) thick if the tapped threads have the necessary mechanical strength.*

10.2.3.10 A terminal plate formed from stock having the thickness specified in 10.2.3.9 may have the metal extruded at the tapped hole to provide two full threads for the binding screw.

10.2.3.11 Upturned lugs or a cupped washer shall be capable of retaining a supply conductor of the size specified in 10.2.3.1 under the head of the screw or washer.

#### 10.2.4 Identified terminals and leads

10.2.4.1 A permanently connected appliance rated 125 or 125/250 volts (3-wire) or less and employing a lampholder of the Edison-screw-shell type, or a single-pole switch or overcurrent-protective device other than an automatic control without a marked off position, shall have one terminal or lead identified for the connection of the grounded conductor of the supply circuit.

10.2.4.2 A terminal intended for the connection of a grounded supply conductor shall be of or plated with metal that is substantially white in color and shall be readily distinguishable from the other terminals, or proper identification of that terminal shall be clearly shown in some other manner, such as on an attached wiring diagram.

10.2.4.3 A lead intended for the connection of a grounded power-supply conductor shall be finished white or natural gray color and shall be readily distinguishable from the other leads.

### 11 Current-Carrying Parts

11.1 A current-carrying part shall be of silver, copper, a copper alloy, stainless steel, or other similar metal.

11.2 Ordinary iron or steel shall not be used as a current-carrying part.

*Exception: Ordinary iron or steel provided with a corrosion-resistant coating, may be used for a current-carrying part if acceptable in accordance with 3.1.1 – 3.1.4, or within a motor or associated governor.*

### 12 Insulating Material

12.1 Material for mounting an uninsulated live part shall be porcelain, phenolic composition, or other equivalent material.

12.2 Ordinary vulcanized fiber may be used for insulating bushings, washers, separators, and barriers, but not as the sole support for uninsulated live parts where shrinkage, current leakage, or warpage may introduce a risk of fire or electric shock.

12.3 A polymeric material used to support a live part, in direct contact with a live part, or within 1/32 inch (0.8 mm) of a live part shall be rated for use at the operating temperature involved and shall have the following material properties, determined in accordance with the Standard for Polymeric Materials – Short Term Property Evaluations, UL 746A:

- a) Volume resistivity not less than 50 megohm-cm;
- b) Comparative tracking index (CTI) performance level category (PLC) not greater than 4; and
- c) A PLC for high-current arc ignition (HAI) and hot wire ignition (HWI) not greater than specified in Table 12.1.

*Exception No. 1: A material with a PLC for HAI greater than specified in Table 12.1 is capable of being used when the spacing over the surface of the material is not less than 1/2 inch (12.7 mm):*

- 1) *Between live parts of opposite polarity;*
- 2) *Between live parts and grounded noncurrent-carrying metal; and*

3) *Between live parts and exposed noncurrent-carrying metal.*

*Exception No. 2: A material with a PLC for HAI greater than specified in Table 12.1 is capable of being used when the material complies with End-Product Arc Resistance, Section 49C.*

*Exception No. 3: A material with a PLC for HWI greater than specified in Table 12.1 is capable of being used when the material complies with Abnormal Overload, Section 49D.*

12.3 revised October 15, 1999

**Table 12.1**  
**Material property**

Table 12.1 added October 15, 1999

Material property (units)	Flame class of material			
	V-0	V-1	V-2	HB
HAI (PLC)	3	2	2	1
HWI (PLC)	4	3	2	2

12.3A A thermoplastic material used to support a live part shall be subjected to the conditioning described in 49A.1.2. As a result of the conditioning, the spacings specified in Spacings, Section 23, and Spacings to Polymeric Enclosures, Section 23.11, shall be maintained and live parts shall remain reliably secured in place.

12.3A added October 15, 1999

12.4 A small molded part, such as a brush cap, shall be constructed to have the necessary mechanical strength and rigidity to withstand the stresses of actual service. A brush cap shall be secured or located so that it is protected from mechanical damage that may result during intended use.

## 13 Internal Wiring

### 13.1 Mechanical protection

13.1.1 Wiring and connection between parts of an appliance shall be protected or enclosed.

*Exception: A length of flexible cord may be employed for external connections if flexibility is essential.*

13.1.2 Wires within an enclosure, a compartment, a raceway, or the like, shall be routed or otherwise protected so that damage to conductor insulation cannot result from contact with any rough, sharp, or moving part.

13.1.3 A hole through which insulated wires pass in a sheet-metal wall within the overall enclosure of an appliance shall be provided with a smooth, rounded bushing or shall have smooth, rounded surfaces upon which the wires may bear.

13.1.4 A flexible cord used for external interconnection as mentioned in the exception to 13.1.1 shall be provided with strain relief and bushings in accordance with the requirements in 10.1.2.1 – 10.1.3.8, and Section 45, Strain-Relief Test, unless the construction is such that the cord will be protected from stress and motion.

13.1.5 Insulated wires may be bunched and passed through a single opening in a metal wall within the enclosure of an appliance.

13.1.6 A conductor utilizing beads for insulation shall not be employed outside an enclosure.

13.1.7 Internal wiring shall consist of wires of a type or types that are acceptable for the application, when considered with respect to the temperature and voltage to which the wiring is likely to be subjected and with respect to its exposure to oil, grease, or other conditions of service to which it is likely to be subjected.

13.1.8 Thermoplastic-insulated wire employed for internal wiring shall be standard building wire or appliance-wiring material acceptable for the purpose.

13.1.9 Type AF wire shall not be employed in an appliance if the wire is likely to be exposed to moisture, including any condensation resulting from operation of the appliance.

*Exception: Type AF wire may be employed if the appliance includes a heating element, and if the wire is subjected to a temperature of more than 80°C (176°F).*

13.1.10 With reference to exposure of insulated wiring through an opening in the enclosure of an appliance, the protection of such wiring required by 13.1.1 is considered to exist if, when judged as though it were film-coated wire, the wiring would be acceptable according to 9.1. Internal wiring not so protected may be accepted if it is secured within the enclosure so that it is unlikely to be subjected to stress or mechanical damage.

No Text on This Page

13.1.11 Wiring that may be located in proximity to combustible material or may be subjected to mechanical damage shall be in armored cable, rigid metal conduit, electrical metallic tubing, metal raceway, or be otherwise equivalently protected.

13.1.12 A nominal 0.110-, 0.125-, 0.187-, 0.205-, or 0.250-inch wide quick-connect terminal shall comply with the requirements in the Standard for Quick-Connect Terminals, UL 310. Other sizes of quick-connect terminals shall be investigated with respect to crimp pull-out, engagement-disengagement forces of the connector and tab, and temperature rise, all tests shall be conducted in accordance with the requirements in the Standard for Quick-Connect Terminals, UL 310.

## 13.2 Splices and connections

13.2.1 Each splice and connection shall be mechanically secure and shall provide reliable electrical contact. A soldered connection shall be mechanically secured before being soldered if breaking or loosening of the connection may result in a risk of fire or electric shock.

13.2.2 For an appliance in which vibration is likely to occur – such as a vibrator – the requirement in 13.2.1 will necessitate the use of lock washers or other equivalent means to prevent wire-binding screws and nuts from becoming loosened.

13.2.3 A splice shall be provided with insulation equivalent to that of the wires involved if permanence of spacing between the splice and other metal parts may not be maintained.

13.2.4 Aluminum conductors, insulated or uninsulated, used as internal wiring, such as for internal connection between current-carrying parts or as motor windings, shall be terminated by a method acceptable for the combination of metals involved at the point of connection.

13.2.5 With reference to the requirements in 13.2.4, a wire-binding screw or a pressure wire connector used as a terminating device shall be acceptable for use with aluminum under the conditions involved – for example, temperature, heat cycling, vibration, and the like.

13.2.6 Insulation consisting of two layers of friction tape, two layers of thermoplastic tape, or of one layer of friction tape on top of one layer of rubber tape, is acceptable on a splice. In determining if splice insulation consisting of coated-fabric, thermoplastic, or other type of tubing is acceptable, consideration is to be given to such factors as its dielectric properties, heat- and moisture-resistant characteristics, and the like. Thermoplastic tape wrapped over a sharp edge is not acceptable.

13.2.7 If stranded internal wiring is connected to a wire-binding screw, loose strands of wire shall be prevented from contacting other uninsulated live parts that are not always of the same polarity as the wire and from contacting dead metal parts. This may be accomplished by use of pressure terminal connectors, soldering lugs, crimped eyelets, soldering all strands of the wire together, or other reliable means.

## 13A Separation of Circuits

13A.1 Conductors of circuits operating at different potentials shall be reliably separated from each other unless the conductors are each provided with insulation rated for the highest potential involved.

Added 13A.1 effective April 15, 2001

13A.2 An insulated conductor shall be retained so that it is not capable of contact with an uninsulated live part of a circuit operating at a different potential.

Added 13A.2 effective April 15, 2001

## 14 Capacitors

14.1 A capacitor provided as a part of a motor and a capacitor connected across the line, such as a capacitor for radio-interference elimination or power-factor correction, shall be housed within an enclosure or container that will protect the plates against mechanical damage and that will prevent the emission of flame or molten material resulting from malfunction or breakdown of the capacitor. The container shall comply with the requirements in 5.2 and 5.3.

*Exception: The individual container of a capacitor may be of sheet metal less than specified in 5.3 or may be of material other than metal if the capacitor is mounted in an enclosure that houses other parts of the appliance and provided that such housing is acceptable for the enclosure of live parts.*

14.2 If a capacitor that is not a part of a capacitor motor or a capacitor-start motor is connected in an appliance that is intended to be automatically or remotely controlled so that malfunction or breakdown of the capacitor would result in a risk of fire, electric shock, or injury to persons, thermal or overcurrent protection shall be provided in the appliance to prevent such a condition.

14.3 A capacitor connected from one side of the line to the frame or enclosure of an appliance shall have a capacitance rating of not more than 0.10 microfarad. See 33.2.

14.4 An appliance that is intended to be controlled by or operated in conjunction with a capacitor or a capacitor/transformer unit shall be supplied with such capacitor or unit.

14.5 Under both normal and abnormal conditions of use, a capacitor employing a dielectric medium more combustible than askarel shall not cause a risk of fire or electric shock and shall be protected against expulsion of the dielectric medium.

## 15 Grounding

### 15.1 General

15.1.1 An appliance of one or more of the following types shall have provision for grounding:

- a) An appliance for use in damp or wet locations and intended to be used in other than residential occupancies.
- b) An appliance intended to be used on a circuit operating at more than 150 volts to ground – see 15.1.3.
- c) An appliance intended for permanent connection to the electrical supply.
- d) An appliance intended for outdoor use.
- e) An appliance intended for use with water or other liquid.

*Exception: A cord-connected appliance may be provided with an acceptable means of double insulation in accordance with the applicable requirements in the Standard for Double Insulation Systems for Use in Electrical Equipment, UL 1097, in lieu of grounding.*



15.1.2 A product marked as being provided with double insulation shall not be provided with a means for grounding. See 53.1.7.

15.1.3 With reference to 15.1.1 (b), a two-wire appliance intended to operate at a nominal potential of 240 volts and any other potential greater than 150 volts, is to be provided with means for grounding in accordance with 15.1.5 and 15.1.6 unless the marked rating on the appliance is 120/240 volts or the appliance is otherwise marked to indicate that it is to be connected to a circuit operating at 150 volts or less to ground.

15.1.4 If a grounding means is provided, whether required or not, it shall be in accordance with 15.1.5. If the appliance is cord connected, the grounding means shall also comply with the requirements in 15.1.8. All exposed dead metal parts and all dead metal parts within the enclosure that are exposed to contact during any user servicing operation and are likely to become energized shall be reliably connected to the means for grounding.

15.1.5 The following are acceptable means for grounding:

- a) In an appliance intended to be permanently connected by a metal-enclosed wiring system, a knockout or equivalent opening in the metal enclosure of the appliance.
- b) In an appliance intended to be permanently connected by a nonmetal-enclosed wiring system, such as nonmetallic-sheathed cable, an equipment-grounding terminal or lead. See 15.1.10 and 15.1.11.
- c) In a cord-connected appliance, an equipment-grounding conductor in the cord.

15.1.6 The grounding conductor of a supply cord shall be secured to the frame or enclosure of the appliance by means of a screw that is not likely to be removed during any servicing operation not involving the power-supply cord, or by other equivalent means. Solder alone shall not be used for securing the grounding conductor. Servicing as mentioned in this paragraph includes repair of the appliance by a qualified service person.

15.1.7 The grounding conductor of a cord-connected appliance shall be connected to the grounding member of an attachment plug. The grounding member shall be fixed.

*Exception: The grounding member of the attachment plug on a portable hand-guided or -supported appliance may be of the movable, self-restoring type.*

15.1.8 A separable connection, such as that provided by an attachment plug and a mating connector or receptacle, shall be such that the equipment-grounding connection is made before connection to and broken after disconnection from the supply conductors.

*Exception: Interlocked plugs, receptacles, and connectors that are not energized when the equipment-grounding connection is made or broken are acceptable.*

15.1.9 If an appliance is intended to be grounded and is provided with means for separate connection to more than one power supply, each such connection shall be provided with a means for grounding.

15.1.10 A terminal intended solely for the connection of an equipment-grounding conductor shall be capable of securing a conductor of the size necessary for the application. A connection device that depends on solder alone shall not be provided for connecting the equipment-grounding conductor.

15.1.11 A wire-binding screw or pressure wire connector intended for the connection of an equipment-grounding conductor shall be located so that it is unlikely to be removed during normal servicing of the appliance.

## 15.2 Grounding identification

15.2.1 The surface of the insulation of a grounding conductor of a flexible cord shall be green with or without one or more yellow stripes.

15.2.2 The surface of an insulated lead intended solely for the connection of an equipment-grounding conductor shall be green with or without one or more yellow stripes, and no other lead shall be so identified.

15.2.3 A wire-binding screw intended for the connection of an equipment-grounding conductor shall have a green-colored head that is hexagonal or slotted, or both. A pressure wire connector intended for connection of such a conductor shall be plainly identified, such as by being marked "G", "GR", "Ground", or "Grounding", or by a marking on a wiring diagram provided on the appliance.

## 16 Heating Elements

16.1 The voltage rating of a heating element employed in an appliance shall not be less than that specified in Table 16.1.

**Table 16.1**  
**Voltage rating of heating element**

Nominal voltage of circuit	Minimum rating of heating element, volts
120	110
208	208
240	220

## 17 Lampholders

17.1 The screw shell of an Edison-base lampholder in a permanently connected appliance, or an appliance equipped with a polarized attachment plug shall be connected to the terminal or lead that is intended to be connected to the grounded conductor of the power-supply circuit.

## 18 Motors

### 18.1 Construction

18.1.1 A motor shall be acceptable for the application, and shall be capable of handling the maximum normal load of the appliance as described in 37.2.1 – 37.2.4 without creating a risk of fire, electric shock, or injury to persons.

18.1.2 A motor winding shall resist the absorption of moisture.

18.1.3 With reference to the requirement in 18.1.2, film-coated wire is not required to be additionally treated to resist absorption of moisture, but fiber slot liners, cloth coil wrap, and similar moisture-absorptive materials are to be provided with impregnation or otherwise treated to prevent moisture absorption.

18.1.4 The diameter of a motor is the diameter of the circle circumscribing the stator frame measured in the plane of the laminations, excluding lugs, fins, boxes, and the like, used solely for motor mounting, cooling, assembly, or connection.

18.1.5 A brush-holder assembly shall be constructed so that when a brush is worn out – no longer capable of performing its function – the brush, spring, and other parts of the assembly are retained to the degree necessary to keep:

- a) Accessible dead metal parts from becoming energized, and
- b) Live parts from becoming accessible.

### 18.2 Overload protection

18.2.1 An appliance employing a motor shall incorporate thermal or overload protection in accordance with 18.2.2 when it is remotely or automatically controlled; or when the appliance is permanently connected, continuous-duty, manually started, and the motor is rated 1 horsepower (746 W) output or less.

18.2.1 revised October 15, 1999

18.2.2 Motor-overload protection required for an appliance shall consist of one of the following:

- a) Thermal protection complying with the applicable requirements in the Standard for Overheating Protection for Motors, UL 2111.

*Exception No. 1: For an appliance that includes a control that positively and reliably limits the length of the time the appliance can operate, the duration of the temperature test and the endurance test, both under locked-rotor conditions, may be less than that specified but shall not be less than the time the appliance can operate.*

*Exception No. 2: A motor intended to move air only by means of an air-moving fan that is integrally attached, keyed, or otherwise fixed to the motor shaft is not required to have running-overload protection.*

*Exception No. 3: A shaded-pole motor with a 2:1 or smaller ratio between locked-rotor and no-load currents and a 1-ampere or smaller difference between no-load and locked-rotor currents is considered to have acceptable overload protection if it is protected against locked-rotor conditions only.*

b) Impedance protection complying with the requirements in the Standard for Overheating Protection for Motors, UL 2111, when the motor is tested as used in the appliance under stalled-rotor conditions.

18.2.2 revised July 7, 1998

18.2.3 For a multispeed motor, the requirement in 18.2.1 applies to all speeds at which the motor is intended to operate.

18.2.4 If a requirement in this standard refers to the horsepower rating of a motor and the motor is not rated in horsepower, use is to be made of the appropriate table of the National Electrical Code, ANSI/NFPA 70-1996, that gives the relationships between horsepower and full-load currents for motors. For a universal motor, the table applying to a single-phase, alternating-current motor is to be used if the appliance is marked for use on alternating current only; otherwise the table applying to direct-current motors is to be used.

18.2.5 The functioning of a motor-protective device provided as part of an appliance, whether such device is required or not, shall not result in a risk of fire or injury to persons.

## **19 Overload- or Thermal-Protective Devices**

19.1 An overload- or thermal-protective device shall have a current and voltage rating not less than the load that it controls.

19.2 A protective device that requires resetting or replacement after it opens shall be readily accessible.

*Exception: The protective device need not be readily accessible provided:*

*a) The appliance, with the protective device shunted out of the circuit, complies with all applicable requirements in this standard; and*

*b) The presence of the protective device would ordinarily be unknown to the user of the appliance because of its location and the omission of reference to the device in the operating instructions, circuit diagrams, and the like, for the appliance.*

19.3 A protective device shall be wholly inaccessible from outside the appliance without opening a door or cover.

*Exception: The operating handle of a circuit breaker, the operating button of a manually operable motor protector, and similar parts may project outside the appliance enclosure.*

19.4 A fuseholder shall be constructed and installed so that no uninsulated live part other than the screw shell or clips will be exposed to contact by persons removing or replacing fuses.

*Exception: The requirement does not apply if the presence of the protective device would ordinarily be unknown to the user of the appliance because of its location and the omission of reference to the device in the operating instructions, circuit diagrams, and the like, for the appliance.*

19.5 The screw shell of a plug-type fuseholder shall be connected toward the load.

## **20 Receptacles**

20.1 A 15- or 20-ampere general-use attachment-plug receptacle in an appliance provided with a means for grounding – a permanently wired appliance or a cord-connected appliance with a grounding conductor in the cord – shall be of the grounding type. The grounding contact of the receptacle shall be electrically connected to dead metal that will be grounded when the appliance is in use.

20.2 A general purpose receptacle rated for use on a nominal 120 volt circuit shall be of a polarized type. The grounded supply conductor shall be connected to the terminal that is substantially white in color or otherwise marked to indicate that it is intended for connection to the grounded supply conductor.

20.3 Each circuit having an attachment-plug receptacle intended for general use, shall have overcurrent protection of not more than 20 amperes provided as a part of the appliance if the overcurrent protection of the branch circuit to which the appliance will properly be connected exceeds that acceptable for the receptacles. The overcurrent protection provided shall be of the time-delay type.

20.4 A fuseholder provided in accordance with 20.3 shall be of Type S construction or shall be of the Edison-base type with a factory-installed nonremovable adapter of Type S construction.

20.5 The face of a receptacle shall:

- a) Be flush with or project beyond a nonconductive surrounding surface, or
- b) Project at least 0.015 inch (0.38 mm) beyond a conductive surrounding surface.

## **21 Switches and Controls**

21.1 A switch or other control device shall have a current and voltage rating not less than that of the load that it controls.

21.2 With reference to the requirement in 21.1, the current rating of a switch that controls an inductive load other than a motor, such as a transformer or an electric-discharge-lamp ballast, shall not be less than twice the rated full-load current of the transformer or ballast unless the switch has been investigated and found acceptable for the application.

21.3 In a permanently connected appliance rated 125 or 125/250 volts (3-wire) or less, no switch or overcurrent-protective device of the single-pole type other than an automatic control without a marked off position shall be electrically connected to a terminal or lead intended for connection to the grounded conductor of the supply circuit.

21.4 A manually operated motor-control switch shall be provided in a cord-connected appliance that employs a motor rated more than 1/3 horsepower (250 W output).

21.5 A switch that controls a medium-base lampholder of other than a pilot or indicating light shall be acceptable for use with tungsten-filament lamps.

21.6 A manually operated, line-connected, single pole switch for appliance on/off operation shall be connected to the ungrounded conductor of the supply cord.

## 22 Attachments

22.1 Functional attachments that are made available or recommended by the manufacturer for use with the basic appliance shall be included in the evaluation of the appliance. Unless recommended by the manufacturer, not more than one attachment shall be evaluated at a time with the appliance.

22.2 The literature accompanying a package containing a basic appliance and attachments intended to be marketed as a complete unit shall indicate what attachments are intended for use with the basic appliance.

22.3 If an attachment is packaged and marketed separately from the basic appliance and recommended for use with it by the manufacturer of the basic appliance, it shall have an assigned catalog number (or equivalent). Also, information packaged with the basic appliance shall identify by catalog number, the attachments which are intended for use with the basic appliance or the catalog number of the basic appliance with which the attachment is intended to be used shall appear in at least one of the following locations:

- a) On the attachment,
- b) On the package housing the attachment, or
- c) In information furnished with the attachment.

## 23 Spacings

23.1 Other than at field-wiring terminals, the spacing between uninsulated live parts of opposite polarity and between an uninsulated live part and a dead metal part that is exposed to contact by persons or that may be grounded shall not be less than the value specified in Table 23.1.

*Exception No. 1: The inherent spacings of a component of the appliance, such as a snap switch, are judged on the basis of the requirements for the component in question.*

*Exception No. 2: An isolated dead metal part may be spaced as provided in 23.5.*

**Table 23.1**  
**Spacings at other than wiring terminals**

Potential involved, volts	Rating of motor employed	Minimum spacings, inch (mm)			
		Motor diameter 7 inches (178 mm) or less <sup>a</sup>			
		Over surface		Through air	
0 – 125	1/3 horsepower (250 W output) or less	1/16	(1.6)	1/16	(1.6)
	More than 1/3 horsepower	3/32	(2.4)	3/32	(2.4)
126 – 250	All motors	3/32	(2.4)	3/32	(2.4)

<sup>a</sup> See 18.1.4.

23.2 Spacings in a motor shall comply with the spacing requirements in the Standard for Electric Motors, UL 1004.

23.3 If an uninsulated live part is not rigidly fixed in position by means other than friction between surfaces, or if a movable dead metal part is in proximity to an uninsulated live part, the construction shall be such that the required minimum spacing will be maintained.

23.4 In an appliance incorporating two or more motors of different horsepower rating, the spacings in the appliance are to be judged on the basis of the rating of the largest motor in the appliance.

23.5 If an isolated dead metal part is interposed between or is in close proximity:

- a) To live parts of opposite polarity,
- b) To a live part and an exposed dead metal part, or
- c) To a live part and a dead metal part that may be grounded,

the spacing may be not less than 3/64 inch (1.2 mm) between the isolated dead metal part and any one of the other parts previously mentioned, provided the total spacing between the isolated dead metal part and the two other parts is not less than the value specified in Table 23.1.

23.6 An insulating lining or barrier of vulcanized fiber or similar materials employed where spacing would otherwise be insufficient shall not be less than 1/32 inch (0.8 mm) thick, and shall be so located or of such material that it will not be adversely affected by arcing, except that vulcanized fiber not less than 1/64 inch (0.4 mm) thick may be used in conjunction with an air spacing of not less than 50 percent of the spacing required for air alone.

*Exception: Thinner insulating material may be used, if upon investigation, it is found to be acceptable for the application.*

23.7 All uninsulated live parts connected to different line- or low-voltage circuits shall be spaced from one another as though they were parts of opposite polarity, in accordance with the requirements in 23.1 and 23.9 and shall be judged on the basis of the highest voltage involved.

23.8 The spacing between uninsulated live parts of opposite polarity and between such parts and dead metal that may be grounded in service is not specified for parts of low-voltage circuits.

23.9 The spacing between wiring terminals of opposite polarity, and the spacing between a wiring terminal and any other uninsulated metal part – dead or live – not of the same polarity, shall not be less than that specified in Table 23.2. See 10.2.3.2.

23.10 At terminal screws and studs to which connection may be made in the field by means of the wire connectors, eyelets, and the like, as described in 10.2.3.2, spacings shall not be less than those specified in Table 23.1 when such connectors, eyelets, and the like, are in such position that minimum spacings – opposite polarity and to dead metal – exist.

**Table 23.2**  
**Spacings at wiring terminals**

Potential involved, volts	Minimum spacings, inch (mm)					
	Between wiring terminals, through air, or over surface		Between terminals and other uninsulated metal parts not always of the same polarity <sup>a</sup>			
			Over surface		Through air	
250 or less	1/4	(6.4)	1/4	(6.4)	1/4	(6.4)

<sup>a</sup> Applies to the sum of the spacings involved where an isolated noncurrent carrying part is interposed.

### 23.11 Spacings to polymeric enclosures

23.11.1 The spacing between a polymeric enclosure and a nonarcing uninsulated live part (a bus bar, a connecting strap, a terminal, or similar part) shall not be less than 1/32 inch (0.8 mm).

*Exception:* A spacing less than 1/32 inch is capable of being used when the enclosure material complies with the requirements for support of a live part prescribed in 12.3.

23.11.1 added October 15, 1999

23.11.2 The spacing between a polymeric enclosure and an arching part (at a commutator, unenclosed switch contacts, or similar part) shall not be less than 1/2 inch (12.7 mm).

*Exception No. 1:* A spacing less than 1/2 inch (12.7 mm) but not less than 1/32 inch (0.8 mm) is acceptable when the material has a PLC for high-current arc ignition (HAI) not greater than specified in Table 12.1.

*Exception No. 2:* A spacing is not required when the material complies with the requirements for support of a live part prescribed in 12.3.

23.11.2 added October 15, 1999

23.11.3 With reference to 23.11.2, the spacing is to be measured from the source of the arc – that is, from the interface of the brush and the commutator, from the interface of the switch contacts, or similar parts.

23.11.3 added October 15, 1999



## PROTECTION AGAINST INJURY TO PERSONS

### 24 General

24.1 If the operation and maintenance of an appliance by the user involves the risk of injury to persons, means shall be provided to reduce the risk.

24.2 When judging an appliance with respect to the requirement in 24.1, consideration shall be given to reasonably foreseeable misuse of the appliance.

24.3 A functional attachment that is made available or recommended by the manufacturer for use with the basic appliance shall be included in the evaluation of the appliance. Unless the manufacturer recommends the use of two or more attachments at the same time, only one attachment at a time is to be evaluated with the appliance.

No Text on This Page

24.4 The adequacy of a guard, a release, an interlock, or the like, and whether such a device is required are to be determined from an investigation of the complete appliance, its operating characteristics, and the likelihood of a risk of injury to persons resulting from a cause other than gross negligence. The investigation is to include consideration of the results of breakdown or malfunction of any one component; but not more than one component at a time, unless one event contributes to another. If the investigation shows that breakdown or malfunction of a particular component can result in a risk of injury to persons, that component is to be investigated for reliability.

24.5 Specific constructions, tests, markings, guards, and the like, are detailed for some common constructions. Specific features and appliances not covered herein are to be given appropriate consideration.

## **25 Sharp Edges**

25.1 An enclosure, a frame, a guard, a handle, or the like, shall not be sufficiently sharp to constitute a risk of injury to persons in normal maintenance and use.

## **26 Enclosures and Guards**

26.1 The rotor of a motor, a pulley, a belt, a gear, a fan, or other moving part that could cause injury to persons shall be enclosed or provided with other means to reduce the likelihood of unintentional contact therewith, and such a part shall not be contacted by the probe illustrated in Figure 9.1.

*Exception: A part or portion of a part that is necessarily exposed to perform the work function need not be enclosed but, when necessary, guarding shall be provided. See 26.4.*

26.2 During the examination of an appliance to determine whether it complies with the requirements in 26.1, a part of the enclosure that may be removed without the use of a tool (to attach an accessory, to make an operating adjustment, or for other reasons) is to be opened or removed.

*Exception: A part need not be opened or removed provided it is marked in accordance with 31.6.*

26.3 Among the factors to be considered in judging the acceptability of an exposed moving part are:

- a) The degree of exposure necessary to perform the intended function,
- b) The sharpness of the moving part,
- c) The likelihood of unintentional contact therewith,
- d) The speed of the moving part, and
- e) The likelihood that a part of the body or clothing would be endangered by the moving part.

These factors are to be considered with respect to both intended operation of the appliance and any reasonably foreseeable misuse.

26.4 Some guards are required to be of the self-restoring type. Other features of guards that are to be considered include:

- a) Removability without the use of tools;
- b) Removability for servicing;
- c) Strength and rigidity;
- d) Completeness;
- e) Creation of additional risk of injury to persons, such as pinch points, and the necessity for additional handling because of the increased need for servicing, such as for cleaning, unjamming, and the like; and
- f) Usage – household or commercial.

26.5 An enclosure or guard over a rotating part shall retain a part that, because of breakage or other reasons, may become loose or may separate from a rotating part, and retain a foreign object that may be struck and propelled by the rotating part.

26.6 If complete guarding of a moving part that could obviously cause injury to persons would defeat the utility of an appliance, a control, such as a momentary contact switch, shall be provided; and an appropriate marking shall be provided in the instruction manual warning the user of the potential risk.

26.7 The rotating massage heads of a shiatsu-type massager shall be such that the distance between the heads is 2 inches (50.8 mm) or more at any position of rotation.

*Exception No. 1: A distance between the heads less than 2 inches (50.8 mm) complies with the requirement when a guard is provided that does not allow body parts to contact the massage heads when the massage heads are less than 2 inches apart. The guard shall extend above the plane of the point where the heads come closest together.*

*Exception No. 2: A distance between the heads less than 2 inches (50.8 mm) complies with the requirement when the massager complies with Shiatsu-Type Massager Entrapment Test, Section 49E.*

Revised 26.7 effective April 15, 2001

## **27 Materials**

27.1 The material of a part, such as an enclosure, a frame, a guard, or the like, the breakage or deterioration of which might result in a risk of injury to persons, shall have such properties as to meet the demand of expected loading conditions.

27.2 The requirement in 27.1 applies to those portions of a part adjacent to a moving part considered to involve a risk of injury to persons.

## **28 Rotating or Moving Members**

28.1 A rotating or moving part that, if it should become disengaged, could create a risk of injury to persons shall be provided with a means to retain the part in place under conditions of use.

28.2 A rotating member, the breakage of which might create a risk of injury to persons, shall be constructed so as to reduce the likelihood of its breakage, or the release or loosening of a part that could become a risk of injury to persons.

No Text on This Page

28.3 To determine whether an appliance employing a series motor complies with the requirement in 28.2, it is to be tested as described in 28.4. Parts that can become a risk of injury to persons shall not work loose as a result of the test.

28.4 For the test discussed in 28.3, an appliance employing a series motor is to be operated for 1 minute at the no-load speed resulting from application of 1.3 times rated voltage. An appliance in which the rotating load may be varied is to be tested for each condition of loading that can occur.

## **29 Switches, Controls, and Interlocks**

29.1 An appliance shall be constructed so as to reduce the likelihood of unexpected operation of any parts capable of causing injury to persons.

29.2 Each function of a multiple-function appliance is to be taken into consideration in determining whether the appliance complies with the requirement in 29.1.

29.3 If, when energized, an appliance has a moving part that may cause injury to persons, a motor control switch, other than a momentary-contact switch, on the appliance shall have a plainly marked off position.

29.4 If unintentional operation of a switch can result in a risk of injury to persons, the actuator of the switch shall be located or guarded so that such operation is unlikely.

29.5 The actuator of a switch may be guarded by recessing, ribs, barriers, or the like.

29.6 A floor- or ground-supported appliance that can travel or rotate to an extent that could result in a risk of injury to persons if left unattended shall be provided with a momentary contact switch that cannot be locked in the on position.

29.7 A device that automatically starts an appliance, such as a timer, an automatically reset overload-protective device, or the like, shall not be employed unless it can be demonstrated that automatic starting will not result in a risk of injury to persons.

29.8 The requirement in 29.7 will necessitate the use of an interlock if moving parts or the like could result in a risk of injury to persons upon the automatic starting or restarting of the motor.

29.9 The actuator of an interlock switch shall be located so that unintentional operation is unlikely. See 29.5.

29.10 Operation of an interlock during intended use shall not inconvenience the operator so as to encourage deliberate defeat of the interlock.

29.11 An interlock shall not be capable of being defeated by materials that could accumulate in intended use.

29.12 An interlock shall be such that it cannot be defeated readily:

- a) Without damaging the appliance,
- b) Without making wiring connections or alterations, or
- c) By using materials that are readily available.

29.13 If an interlock is actuated by movement of a guard, the arrangement shall be such that the guard is in place when the interlock is in the position that permits operation of the parts being guarded. With the guard removed, the interlock shall comply with the requirement in 29.9.

### **30 Stability**

30.1 If a portable appliance overturns when tested as described in 30.2 and 30.4, a risk of injury to persons shall not result.

*Exception: An appliance that is completely hand supported in intended use need not be tested.*

30.2 The appliance is not to be energized during the stability test. The test is to be conducted under conditions most likely to cause the appliance to overturn. The following conditions are to be such as to result in the least stability:

- a) The position of all doors, drawers, casters, and other movable or adjustable parts, including that of the supply cord resting on the surface supporting the appliance;
- b) Connection of or omission of any attachment made available by or recommended by the manufacturer;
- c) Provision of or omission of any normal load if the appliance is intended to contain a liquid or other mechanical load; and
- d) Direction in which the appliance is tipped or the supporting surface is inclined. See 30.3.

30.3 In conducting the stability test, the appliance is to be:

- a) Placed on a plane inclined at an angle of 10 degrees from the horizontal, or
- b) Tipped through an angle of 10 degrees from an at rest position on a horizontal plane.

30.4 With reference to the requirement in 30.3 (b), for an appliance that is constructed so that while being tipped through an angle of 10 degrees a part or surface of the appliance not normally in contact with the horizontal supporting surface touches the supporting surface before the appliance has been tipped through an angle of 10 degrees, the tipping is to be continued until the surface or plane of the surface of the appliance originally in contact with the horizontal supporting surface is at an angle of 10 degrees from the horizontal supporting surface.



30.5 An appliance not intended to move from its de-energized position to perform its intended function that, when operated, moves from its de-energized position shall be provided with an anchoring means.

### **31 Markings**

31.1 An appliance having a hidden or unexpected risk of injury to persons shall be marked to inform the user of the risk.

31.2 A cautionary marking shall be permanent and legible and shall be located on a permanent part of the appliance.

31.3 A cautionary marking intended to instruct the operator, shall be legible and visible from the position normally assumed by the operator when starting the appliance or from the position normally assumed for the specific operation involved. Other such markings for servicing or making settings and adjustments shall be legible and visible to the individual when such work is being accomplished.

31.4 A marking intended to inform the user of a risk of injury to persons shall be prefixed by a signal word "CAUTION ", "WARNING ", or "DANGER." The marking shall be in letters not less than 3/32 inch (2.4 mm) high. The signal word shall be more prominent than any other required marking on the appliance.

31.5 If, when energized, an appliance has a moving part that may cause injury to persons, a switch that controls the motor that drives the part shall have a plainly marked off position.

31.6 A part of an enclosure as described in the exception to 26.2 shall be marked to indicate that such servicing is to be done with the appliance disconnected from the supply circuit.

31.7 A treadmill shall be marked on the top of the handrail, on the control console, or in a place that is readily visible to the user before operation with the word "CAUTION" and the following or equivalent wording: "Risk of Injury to Persons – To Avoid Injury, Stand on the Siderails Before Starting Treadmill. Read Instruction Manual Before Using."

31.7 added October 15, 1999

## **PERFORMANCE**

### **32 General**

32.1 Unless otherwise noted, all tests are to be conducted with the appliance connected to a supply circuit as specified in 32.2. The voltage of the supply circuit shall be as specified in Table 32.1.

**Table 32.1**  
**Test voltages**

Maximum marked rating range	Test voltage
110 – 120 volts, ac	120 volts, ac
220 – 240 volts, ac	240 volts, ac
110 – 120 volts, dc	115 volts, dc
220 – 240 volts, dc	230 volts, dc
Other	Highest value of marked range

32.2 An appliance having a single frequency rating is to be tested at that frequency. An appliance rated ac/dc or dc – 60 hertz is to be tested on direct current or 60-hertz alternating current, whichever results in higher temperatures. An appliance rated 25 – 60 or 50 – 60 hertz is to be tested on 60-hertz alternating current.

### 33 Leakage-Current Test

33.1 A cord-connected product shall be tested in accordance with 33.3 – 33.7. Leakage current shall not be more than:

- a) 0.5 milliamperes for an ungrounded 2-wire appliance,
- b) 0.5 milliamperes for a grounded 3-wire portable appliance, and
- c) 0.75 milliamperes for a grounded 3-wire appliance:
  - 1) Employing a standard attachment plug rated 20 amperes or less, and
  - 2) Intended to be fastened in place or located in a dedicated space.

33.2 Leakage current refers to all currents, including capacitively coupled currents, that may be conveyed between exposed conductive surfaces of an appliance and ground or other exposed conductive surfaces of an appliance.

33.3 All exposed conductive surfaces are to be tested for leakage currents. Leakage currents from these surfaces are to be measured to the grounded-supply conductor individually as well as collectively if simultaneously accessible, and from one surface to another if simultaneously accessible. A part is considered to be exposed unless it is guarded by an enclosure that is acceptable for protection against the risk of electric shock as defined in Section 9, Accessibility of Uninsulated Live Parts and Film-Coated Wire. Surfaces are considered to be simultaneously accessible if they can be readily contacted by one or both hands of a person at the same time. These measurements do not apply to terminals operating at voltages that are not considered to involve a risk of electric shock. If all accessible surfaces are bonded together and connected to the grounding conductor of the power-supply cord, the leakage current can be measured between the grounding conductor and the grounded supply conductor.

33.4 If a conductive surface other than metal is used for the enclosure or part of the enclosure, the leakage current is to be measured using a metal foil having an area of 10 by 20 centimeters in contact with the surface. If the surface is less than 10 by 20 centimeters, the metal foil is to be the same size as the surface. The metal foil is not to remain in place long enough to affect the temperature of the appliance.

33.5 The measurement circuit for leakage current is to be as illustrated in Figure 33.1. The measurement instrument is defined in (a) – (c). The meter that is actually used for a measurement need only indicate the same numerical value for a particular measurement as would the defined instrument. The meter used need not have all the attributes of the defined instrument.

- a) The meter is to have an input impedance of 1500 ohms resistive shunted by a capacitance of 0.15 microfarad.
- b) The meter is to indicate 1.11 times the average of the full wave rectified composite waveform of voltage across the resistor or current through the resistor.
- c) Over a frequency range of 0 – 100 kilohertz, the measurement circuitry is to have a frequency response – ratio of indicated to actual value of current – that is equal to the ratio of the impedance of a 1500-ohm resistor shunted by a 0.15-microfarad capacitor to 1500 ohms. At an indication of 0.5 or 0.75 milliampere, the measurement is to have an error of not more than 5 percent at 60 hertz.

33.6 Unless the meter is being used to measure leakage from one part of an appliance to another, it is to be connected between accessible parts and the grounded-supply conductor.

**Figure 33.1**  
**Leakage current measurement circuits**

Figure 33.1 revised July 7, 1998

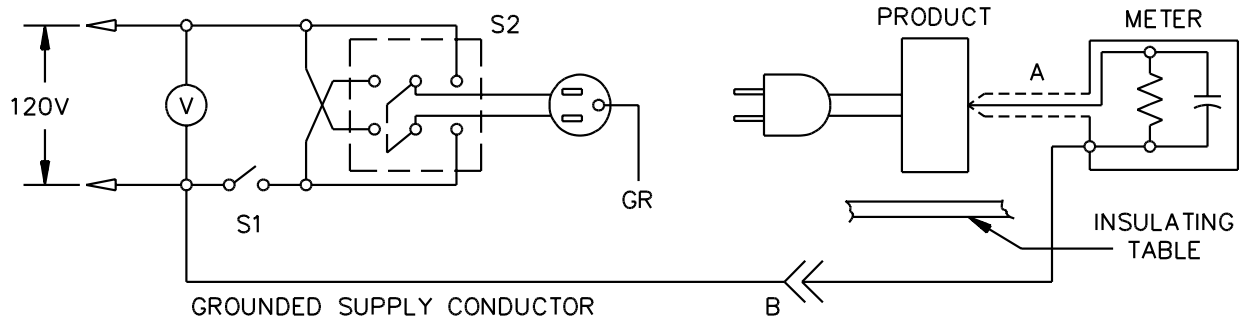

Product intended for connection to a 120-volt power supply, as illustrated above.

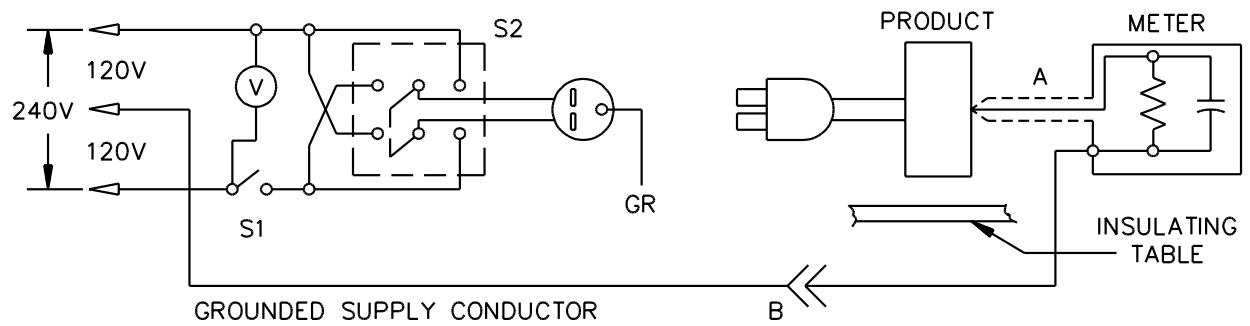

Product intended for connection to a 3-wire, grounded neutral power supply, as illustrated above.

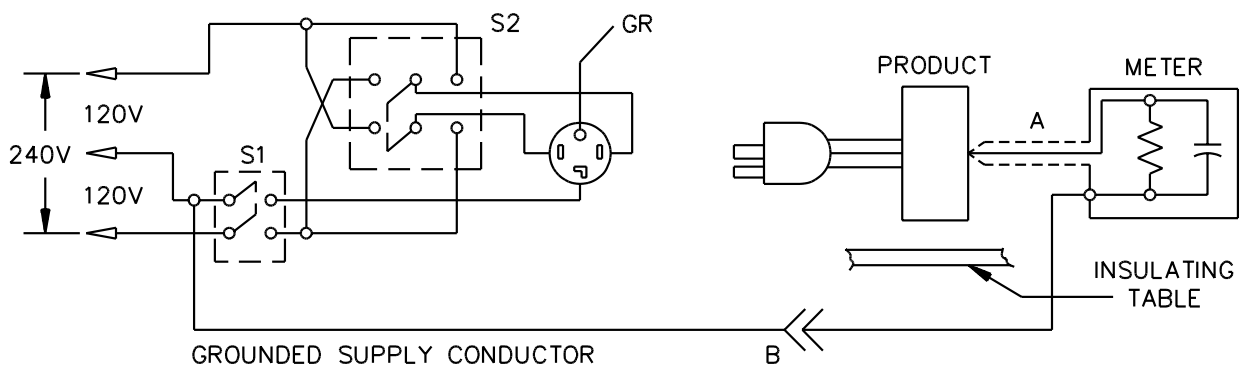

Product intended for connection to a 3-wire, grounded neutral power supply, as illustrated above.

LC300J

A – Probe with shielded lead.

B – Separated and used as clip when measuring currents from one part of product to another.

33.7 A sample of the appliance is to be tested for leakage current starting with the as-received condition but with its grounding conductor, if any, open at the attachment plug. The as-received condition is without prior energization except as may occur as part of the production-line testing. The test sequence, with reference to the measuring circuit – Figure 33.1 – is to be as follows:

- a) With switch S1 open, the appliance is to be connected to the measuring circuit. Leakage current is to be measured using both positions of switch S2, and with the appliance switching devices in all their normal operating positions.
- b) Switch S1 is then to be closed, energizing the appliance, and within 5 seconds, the leakage current is to be measured using both positions of switch S2, and with the appliance switching devices in all their normal operating positions.
- c) The leakage current is to be monitored until thermal stabilization. Both positions of switch S2 are to be used in determining this measurement. Thermal stabilization is to be obtained by operation as in the temperature test.

33.8 Normally, the complete leakage current test program as covered by 33.7 is to be conducted without interruption for other tests. However, with the concurrence of those concerned, the leakage-current tests may be interrupted for the purpose of conducting other nondestructive tests.

#### **34 Leakage Current Following Humidity Conditioning**

34.1 An appliance as described in 33.1 shall comply with the requirements for leakage current in 33.1 following exposure for 48 hours to air having a relative humidity of  $88 \pm 2$  percent at a temperature of  $32 \pm 2^\circ\text{C}$  ( $90 \pm 4^\circ\text{F}$ ).

34.2 To determine whether an appliance complies with the requirement in 34.1, a sample of the appliance is to be heated to a temperature just above  $34^\circ\text{C}$  ( $93^\circ\text{F}$ ) to reduce the likelihood of condensation of moisture during conditioning. The heated sample is to be placed in the humidity chamber and is to remain for 48 hours under the conditions specified in 34.1. Following the conditioning and while still in the test chamber, the sample is to be tested unenergized as described in 33.7 (a). Either while the sample is still in the chamber or immediately after it has been removed, the sample is to be energized and tested as described in 33.7 (b) and (c). The test is to be discontinued when the leakage current stabilizes or decreases.

#### **35 Starting-Current Test**

35.1 An appliance shall start and operate as intended on a circuit protected by an ordinary (not time-delay) fuse having a current rating corresponding to that of the branch circuit to which the appliance should be connected. The performance is unacceptable if the fuse opens or an overload protector provided as part of the appliance trips.

*Exception No. 1: The requirement concerning an ordinary fuse does not apply if:*

- a) The construction of the appliance or the nature of its usage is such that it is likely to be used continually on the same branch circuit after installation,*
- b) The appliance will start and operate as intended on a circuit protected by a time-delay fuse, and*
- c) The appliance is marked in accordance with 53.1.6.*

*Exception No. 2: The requirement concerning an ordinary fuse does not apply to a household appliance that would normally be used on a 15- or 20-ampere branch circuit, provided that the appliance starts and operates as intended on a circuit protected by a time-delay fuse having an ampere rating corresponding to that of the branch circuit on which the appliance would normally be used.*

35.2 In a test to determine whether an appliance complies with the requirement in 35.1, the appliance is to be started three times, with the appliance at room temperature at the beginning of the test. Each start of the motor is to be made under conditions representing the beginning of intended operation – the beginning of the intended operating cycle, in the case of an automatic appliance – and the motor is to be allowed to come to rest between successive starts.

## **36 Input Test**

36.1 The current or wattage input to an appliance shall not be more than 110 percent of the rated value when the appliance is operated under the condition of maximum normal load as described in 37.2.1 – 37.2.4, as applicable.

## **37 Temperature Test**

### **37.1 General**

37.1.1 An appliance shall be tested as described in 37.2.1 – 37.2.4, and shall not reach a temperature at any point high enough to cause a risk of fire, to damage any materials in the appliance, or to exceed the temperature rises specified in Table 37.1.

37.1.2 A thermal- or overload-protective device shall not open the circuit during the temperature test.

37.1.3 All values of temperature rise in Table 37.1 are based on an assumed ambient temperature of 25°C (77°F). Tests may be conducted at any ambient temperature within the range of 10 – 40°C (50 – 104°F).

37.1.4 Ordinarily, coil or winding temperatures are to be measured by thermocouples unless the coil is inaccessible for mounting of these devices – for example, a coil immersed in sealing compound – or unless the coil wrap includes thermal insulation or more than two layers – 1/32 inch (0.8 mm) maximum – of cotton, paper, rayon, or the like. For a thermocouple-measured temperature of a coil of an alternating-current motor, other than a universal motor, having a diameter of 7 inches (178 mm) or less – subitems 1 and 3 of item A in Table 37.1 – the thermocouple is to be mounted on the integrally applied insulation on the conductor.

**Table 37.1**  
**Temperature rises**

Table 37.1 revised October 15, 1999

Materials and components	°C	°F
<p>A. MOTORS</p> <p>1. Class A insulation systems on coil windings of an a-c motor having a frame diameter of 7 inches (178 mm) or less, not including a universal motor and on a vibrator coil<sup>a,b</sup></p> <p>a. In an open motor and on a vibrator coil: Thermocouple or resistance method</p> <p>b. In a totally enclosed motor: Thermocouple or resistance method</p> <p>2. Class A insulation systems on coil windings of an a-c motor having a frame diameter of more than 7 inches (178 mm), of a d-c motor and of a universal motor<sup>a,b</sup></p> <p>a. In an open motor: Thermocouple method Resistance method</p> <p>b. In a totally enclosed motor: Thermocouple method Resistance method</p> <p>3. Class B insulation systems on coil windings of an a-c motor having a frame diameter of 7 inches (178 mm) or less, not including a universal motor<sup>a,b</sup></p> <p>a. In an open motor: Thermocouple or resistance method</p> <p>b. In a totally enclosed motor: Thermocouple or resistance method</p> <p>4. Class B insulation systems on coil windings of an a-c motor having a frame diameter of more than 7 inches (178 mm), of a d-c motor, and of a universal motor<sup>a,b</sup></p> <p>a. In an open motor: Thermocouple method Resistance method</p> <p>b. In a totally enclosed motor: Thermocouple method Resistance method</p> <p>B. COMPONENTS</p>	<p>75</p> <p>80</p> <p>65</p> <p>75</p> <p>70</p> <p>80</p> <p>95</p> <p>100</p> <p>85</p> <p>95</p> <p>90</p> <p>100</p>	<p>135</p> <p>144</p> <p>117</p> <p>135</p> <p>126</p> <p>144</p> <p>171</p> <p>180</p> <p>153</p> <p>171</p> <p>162</p> <p>180</p>

Table 37.1 Continued on Next Page

Table 37.1 Continued

Materials and components	°C	°F
1. Capacitors:		
a. Electrolytic <sup>c</sup>	40	72
b. Other types <sup>d</sup>	65	117
2. Fuses <sup>e</sup>	65	117
3. Relay, solenoid, and coils (except motor coil windings and transformers) with:		
a. Class 105 insulated systems		
Thermocouple method	65	117
Resistance method	85	153
b. Class 130 insulation systems		
Thermocouple method	85	153
Resistance method	105	189
4. Vibrator coils with Class 130 insulation systems:		
Thermocouple or resistance method	95	171
5. Sealing Compound	40	104
		less than melting point
6. Transformers with Class 105 insulation systems:		
Thermocouple method	65	117
Resistance method	75	135
<b>C. CONDUCTORS</b>		
1. Copper conductors:		
a. Tinned or bare strands having:		
(1) A diameter less than 0.015 inch (0.38 mm)	125	225
(2) A diameter of 0.015 inch or more	175	315
b. Plated with nickel, gold, silver, or a combination of these	225	405
2. Rubber- or thermoplastic-insulated wire and cord <sup>e, f, g</sup>	35	63
<b>D. ELECTRICAL INSULATION – GENERAL</b>		
1. Fiber employed as electrical insulation	65	117
2. Phenolic composition employed as electrical insulation or as a part the deterioration of which could result in a risk of fire or electric shock <sup>e</sup>	125	225
3. Varnished-cloth insulation	60	108
<b>E. SURFACES</b>		
1. A surface upon which a product may be placed or mounted in service, and a surface that may be adjacent to the product when it is so placed or mounted	65	117
2. Any point within a terminal box or wiring compartment of a permanently connected product in which power-supply conductors are to be connected, including such conductors themselves, unless the product is marked in accordance with 53.2.1.	35	63
3. Wood or other combustible material, including the inside surface of the test enclosure and the surface supporting the product	65	117
<sup>a</sup> At a point on the surface of a coil where the temperature is affected by an external source of heat, the temperature measured by means of a thermocouple may be more than the maximum acceptable temperature specified in this table provided the temperature, as measured by the resistance method, is not more than that specified. The temperature measured by means of a thermocouple may be more than the specified value by:		

Table 37.1 Continued on Next Page



Table 37.1 Continued

Materials and components	°C	°F
<ol style="list-style-type: none"> <li>1. 5°C (9°F) for Class A insulation systems on coil windings of alternating-current motors having a diameter of 7 inches (178 mm) or less, open type,</li> <li>2. 10°C (18°F) for Class B insulation systems on coil windings of alternating-current motors having a diameter of 7 inches or less, open type,</li> <li>3. 15°C (27°F) for Class A insulation systems on coil windings of alternating-current motors having a diameter of more than 7 inches, open type,</li> <li>4. 20°C (36°F) for Class B insulation systems on coil windings of alternating-current motors having a diameter of more than 7 inches, open type,</li> <li>5. 15°C (27°F) for Class 105 insulation systems on windings of a relay, a solenoid, and the like.</li> <li>6. 15°C (27°F) for Class 130 insulation systems on windings of a relay, a solenoid, and the like.</li> </ol>		
<sup>b</sup> See 18.1.4.		
<sup>c</sup> For an electrolytic capacitor that is physically integral with or attached to a motor, the maximum acceptable temperature rise on insulating material integral with the capacitor enclosure may be not more than 65°C (117°F).		
<sup>d</sup> A capacitor that operates at a temperature rise of more than 65°C (117°F) may be judged on the basis of its marked temperature.		
<sup>e</sup> These limitations do not apply to compounds and components that have been found acceptable for use at higher temperatures.		
<sup>f</sup> A rubber-insulated conductor within a Class-A-insulated motor, a rubber-insulated motor lead, and a rubber-insulated conductor of a flexible cord entering a motor may be subjected to a higher temperature if the conductor is provided with sleeving or a braid that has been investigated and found acceptable for use at the higher temperature. This does not apply to thermoplastic-insulated wires or cords		
<sup>g</sup> A short length of rubber- or thermoplastic-insulated flexible cord exposed to a temperature of more than 60°C (140°F), such as at terminals, is acceptable if supplementary heat-resistant insulation of the necessary dielectric strength is employed on the individual conductors of the cord to protect the conductor insulation against deterioration.		

37.1.5 Thermocouples are to consist of wires not larger than No. 24 AWG (0.21 mm<sup>2</sup>) and not smaller than No. 30 AWG (0.05 mm<sup>2</sup>). Whenever referee temperature measurements by thermocouples are necessary, thermocouples consisting of No. 30 AWG iron and constantan wire and a potentiometer-type instrument are to be used. The thermocouple wire is to conform with the requirements for special thermocouples as listed in the Initial Calibration Tolerances for Thermocouples table in Temperature Measurement Thermocouples, ANSI/ISA MC96.1.

37.1.5 revised October 15, 1999

37.1.6 If an appliance incorporates a reel for the power-supply cord, one-third of the length of the cord is to be unreeled for the temperature test.

37.1.7 For an appliance that is obviously not intended for continuous operation, the probable intermittent of short-time operation of the appliance is to be taken into consideration when conducting the temperature test.

37.1.8 With reference to those tests that are to be continued until constant temperatures are attained, thermal equilibrium is considered to exist when three successive readings taken at intervals of 10 percent of the previously elapsed duration of the test, but not less than 5-minute intervals, indicate no change.

## 37.2 Maximum normal load

37.2.1 In tests on an appliance, maximum normal load is considered to be the load that approximates as closely as possible the most severe conditions of intended use. It is not a deliberate overload except as the conditions of actual use are likely to be somewhat more severe than the maximum load conditions that are recommended by the manufacturer of the appliance. However, appliances having features not contemplated in these test procedures may be tested as necessary to meet the intent of these requirements.

37.2.2 The operation of a hand-held appliance need not approximate those conditions of actual service. An appliance that is intended for household use is to be operated for 20 minutes. An appliance that is intended for commercial use is to be operated through repeated cycles of 5 minutes on and 5 minutes off until constant temperatures have been reached.

37.2.3 A hand-supported appliance that includes a heater that can be energized independently of the vibrator or motor is also to be tested with only the heater energized until temperatures become constant.

37.2.4 A massage machine that is not intended to be hand-supported is to be operated continuously until temperatures become constant.

### **38 Surface Temperatures**

38.1 During the temperature test, the temperature of a surface that may be contacted by the user shall not be more than the value specified in 38.2 or Table 38.1, as applicable. If the test is conducted at a room temperature of other than 25°C (77°F), the results are to be corrected to that temperature.

No Text on This Page

**Table 38.1**  
**Maximum surface temperatures**

Location	Composition of surface <sup>a</sup>			
	Metal		Nonmetallic	
Handles or knobs that are grasped for lifting, carrying, or holding	50°C	(122°F)	60°C	(140°F)
Handles or knobs that are contacted but do not involve lifting, carrying, or holding	60°C	(140°F)	85°C	(185°F)
Surfaces of a hand-held appliance that are known to be hot and are intended to be contacted by the user	60°C	(140°F)	85°C	(185°F)
Surfaces known to be hot, other than the area of a heating pad or of a hand-held appliance, and intended to be contacted by the user	45°C	(113°F)	50°C	(122°F)
Other surfaces subject to contact during operation or user maintenance	60°C	(140°F)	85°C	(185°F)

<sup>a</sup> A handle, knob, or the like, made of a material other than metal, that is plated or clad with metal having a thickness of 0.005 inch (0.127 mm) or less is considered to be, and is judged as, a nonmetallic part.

38.2 The maximum acceptable temperature rise on external surfaces of an appliance employing a heating pad shall not exceed 55°C (99°F) in the area of the heating pad.

### 39 Surface-Temperature Test

39.1 A small, cord-connected appliance of the hand-supported type shall not attain a temperature of more than 125°C (257°F) on any exterior surface that may be laid on combustible material or against which combustible material may be laid, and there shall be no emission of smoke or molten material.

39.2 To determine whether an appliance complies with the requirement in 39.1, the appliance is to be operated until constant temperatures are attained. The appliance may be stationary during the test, and simulation of actual service conditions need not be attempted.

### 40 Dielectric Voltage-Withstand Test

40.1 An appliance shall withstand for 1 minute without breakdown the application of a 60-hertz essentially sinusoidal potential between live parts and dead metal parts with the appliance at the maximum operating temperature reached in intended use. The test potential for the primary circuit shall be:

- a) One-thousand volts for an appliance employing a motor rated 1/2 horsepower (373 W output) or less and 250 volts or less.
- b) One-thousand volts plus twice the rated voltage for (1) an appliance employing a motor rated more than 1/2 horsepower or more than 250 volts, or (2) an appliance applied directly to persons – see (c).
- c) Twenty-five hundred volts for an appliance that is applied in a wet or moist condition directly to persons.

40.2 The test potential for the secondary circuit of an appliance employing a transformer or autotransformer shall be:

- a) One-thousand volts if the secondary operates at 51 – 250 volts.
- b) Five-hundred volts if the secondary operated at 50 volts or less.

*Exception: This does not apply if the secondary circuit is supplied from a Class 2 transformer.*

40.3 A capacitor used for radio-interference elimination or arc suppression shall withstand for 1 minute without breakdown, the application of a 60-hertz essentially sinusoidal potential between live parts of opposite polarity with the appliance at the maximum operating temperature reached in intended use. The test potential shall be 1000 volts for an appliance employing a motor rated 1/2 horsepower (373 W output) or less and 250 volts or less.

40.4 To determine whether an appliance complies with the requirements in 40.1 – 40.3, the appliance is to be tested by means of a 500 volt-ampere or larger transformer, having an output voltage that is essentially sinusoidal and can be varied. The applied potential is to be increased from zero until the required test value is reached and is to be held at that value for 1 minute. The increase in the applied potential is to be at a substantially uniform rate and as rapid as consistent with its value being correctly indicated by a voltmeter.

40.5 For an appliance that employs a heating pad, the test potential is also to be applied between interconnected current-carrying parts of each sample appliance and sheets of metal foil on the sides or faces of the appliance. The appliance, with the foil on either side or face, is to be placed between felt mats as described in 40.6. A uniform pressure of 25 pounds force per square foot (1200 N/m<sup>2</sup>) is to be applied to the felt mats so that the metal foil is in close proximity to the appliance.

40.6 The felt mats mentioned in 40.5 are to be 1 inch (25 mm) thick and have an area sufficient to completely cover the area of the appliance containing the pad and to extend for not less than 2 inches (51 mm) all the way around the pad area.

#### **41 Resistance to Moisture Test**

41.1 An appliance that employs a heating pad and a vinyl or treated fabric covering in the area of the heating pad shall be tested as described in 41.2 and 41.3. As a result of the test, the leakage current for an appliance shall not exceed 0.5 milliamperes at 120 volts, and the covering shall neither lose its moisture-resistant properties nor develop hard spots.

41.2 To determine whether an appliance complies with the requirements in 41.1, a cushion-type appliance is to be placed on a 1-inch (25-mm) thick felt mat, and an appliance of other construction, such as a chair, is to have a 1-inch thick felt mat placed against that portion of the appliance containing the heating pad. The sample is then to be continuously operated at its maximum operating temperature. After operation for 300 hours, the surface of the covering is to be carefully examined to determine whether there are any hard spots in the material. It is then to be folded and manipulated back and forth several times as allowed by the construction of the appliance to flex the material throughout the entire surface. Following the manipulation, the appliance is to be tested for leakage current in accordance with the Leakage-Current Test, Section 33.

41.3 The sample or the area of the sample containing the heating pad is then to be placed in a horizontal plane, with the edges of the appliance turned up at right angles for approximately 1 inch (25 mm) to form a shallow tray. If the edges of the appliance cannot be turned up, supplementary sides may be attached to or formed on the appliance to hold the solution. The side or face that was in contact with the felt mat during the 300-hour test is to be the upper or inside surface of the tray. A solution of approximately 8 grams of NaCl per 1000 cubic centimeters of water is to be introduced into the tray to a minimum depth of 1/4 inch (6 mm), and the leakage current between the electrolyte and the appliance is then to be measured. The solution is to be allowed to remain on the covering for 3 hours, and if there is no leakage current, the test may be discontinued; but, if any leakage current is measured, the test is to be continued until ultimate results are obtained, but not longer than 7 hours.

## 42 Flooding of Live Parts Test

42.1 The malfunction of a timer switch or of a float- or pressure-operated switch, or the deterioration or damage of a boot or diaphragm of rubber or similar material shall not cause flooding of the electrical components of an appliance that employs water or other electrically conductive liquid in its operation.

42.2 In a test to determine whether an appliance complies with the requirement in 42.1 with respect to deterioration or damage of a boot or diaphragm due to flexing, such component is to be removed completely and the appliance operated through one complete cycle of intended operation. If flexing is not present, but if a rubber part is subjected to hot soapy water, the material is to be investigated to determine if deterioration or damage of the part would create a risk of fire or electric shock. This investigation is to include consideration of the effects of heat, air pressure, soap solutions, and other factors contributing to the aging.

42.3 Infrequent motion of small amplitude, such as that experienced during intended operation by a diaphragm covering a pressure-sensitive switch, is not considered to constitute flexing, as far as these requirements are concerned.

## 43 Switch and Control Test

43.1 A switch or other device that controls a motor of an appliance, or that controls a solenoid, a relay coil, or the like, shall perform acceptably when subjected to an overload test consisting of 50 cycles of operation as described in 43.2 – 43.4, as applicable. There shall be no electrical or mechanical malfunction or breakdown of the device or undue burning or pitting of the contacts, and the fuse in the grounding connection shall not open.

*Exception No. 1: A device known to be acceptable for the application need not be tested.*

*Exception No. 2: A device interlocked so that it will never break the locked-rotor motor current need not be tested.*

43.2 In a test to determine whether the switch or other control device complies with the requirement in 43.1, exposed dead metal parts of the appliance are to be connected to ground through a 3-ampere plug fuse. During the test the device is to be operated at a rate of not more than 10 cycles per minute, except that a faster rate of operation may be employed if agreeable to those concerned.

43.3 When testing a switch or other control device that controls a solenoid, a relay coil, or the like, the appliance is to be connected to a supply circuit of rated frequency and 110 percent of the voltage specified in 32.1. The load on the device being tested is to be the same as that which it is intended to control in service.

43.4 When testing a switch or other control device that controls a motor, the rotor of the motor is to be locked in position. The supply-circuit connection is to be such that any single-pole, current-interrupting device will be located in the ungrounded conductor of the supply circuit. If the appliance is intended for use on direct current, or on direct current as well as alternating current, the exposed dead metal parts of the appliance are to be connected so as to be positive with respect to a single-pole, current-interrupting control device.

## **44 Thermostat Test**

### **44.1 General**

44.1.1 A thermostat employed in a heating pad shall comply with 44.3.1 – 44.5.1.

### **44.2 Original calibration**

44.2.1 The cutoff temperature of each of six thermostats that are identical to the thermostats employed in the heating pad is to be measured by any method whereby the temperature can be closely regulated and accurately measured.

### **44.3 Overload**

44.3.1 When tested as described in 44.3.2, there shall be no electrical or mechanical breakdown or undue pitting or burning of the contacts in any of the six calibrated thermostats.

44.3.2 The thermostats are to be operated automatically on a 125-volt supply circuit for 100 cycles at a rate of not more than 6 cycles per minute, making and breaking twice the maximum noninductive current that the thermostat normally carries in the pad. An alternating-current supply circuit is to be used if the pad is rated for use on only alternating current. A direct-current supply circuit is to be used if the pad is rated for use on only direct current or for use on both direct current and alternating current.

### **44.4 Endurance**

44.4.1 There shall be no electrical or mechanical breakdown or undue pitting or burning of the contacts in any of the six thermostats that performed acceptably in the overload test described in 44.3.2 as the result of their additional automatic operation on a 125-volt alternating current supply circuit for at least 100,000 cycles at a rate of not more than 30 cycles per minute making and breaking the maximum noninductive current that the thermostat normally carries in the pad. See 40.6.

44.4.2 This test is intended to represent at least 1000 hours of service under conditions that produce the fastest operation of a thermostat in the pad. The test is to be continued beyond 100,000 cycles if necessary to represent 1000 hours of service.

## 44.5 Recalibration

44.5.1 After the six thermostats that performed acceptably in the endurance test described in 44.4.1 and 44.4.2 have been kept at a temperature of 0°C (32°F) for 1 hour and then at a temperature of 125°F (257°F) for an additional hour, the cutoff temperature of each of the six thermostats will not be more than 5°C (9°F) higher than the original cutoff temperature determined in accordance with 44.2.1.

## 45 Strain-Relief Test

45.1 The strain-relief means provided on an attached flexible cord, when tested in accordance with 45.2, shall withstand for 1 minute without displacement a direct pull of 35 pounds (156 N) applied to the cord, with the connections within the appliance disconnected.

*Exception: The pull applied to a Type TP or TPT cord is to be 20 pounds (89 N).*

45.2 A 35 pound (15.9 kg) weight is to be suspended on the cord and supported by the appliance so that the strain-relief means will be stressed from any angle that the construction of the appliance permits. The strain relief is not acceptable if, at the point of disconnection of the conductors, there is such movement of the cord as to indicate that stress would have resulted on the connections.

### 45A Strain-Relief Clamp Test

45A.1 With reference to Exception No. 1 to 10.1.2.3, four samples of the clamp that have been applied to the cord in the intended manner are to be tested as specified in 45A.2 and 45A.3. As a result, the samples, installed in the equipment as intended, shall comply with Dielectric Voltage-Withstand Test, Section 40, and Strain-Relief Test, Section 45.

Added 45A.1 effective April 15, 2001

45A.2 One sample is to be subjected to Strain-Relief Test, Section 45, and Dielectric Voltage-Withstand Test, Section 40, in the as-received condition.

Added 45A.2 effective April 15, 2001

45A.3 The other three samples are to be conditioned in an air-circulating oven for 168 hours. The oven temperature is to be 10°C (18°F) higher than the maximum temperature measured on the cord at the strain-relief device during the test described in Temperature Test, Section 37, and not less than 70°C (158°F). After cooling to room temperature, the conditioned samples are to be subjected to Strain-Relief Test, Section 45, and Dielectric Voltage-Withstand Test, Section 40.

Added 45A.3 effective April 15, 2001

45A.4 The potential in Dielectric Voltage-Withstand Test, Section 40, is to be applied between the conductors and, for a clamp of metal, the potential is also to be applied between the conductors and the clamp.

Added 45A.4 effective April 15, 2001

## 46 Flexing and Twisting Test

### 46.1 Flexing

46.1.1 An appliance employing a heating pad that may be subjected to flexing or twisting, or both, shall be tested as described in 46.1.3 – 46.2.4. Following the test:

- a) The appliance shall comply with the requirements in the:



- 1) Leakage-Current Test, Section 33;
  - 2) Strain-Relief Test, Section 45;
  - 3) Dielectric Voltage-Withstand Test, Section 40; and
  - 4) Resistance to Moisture Test, Section 41; and
- b) There shall be no:
- 1) Loosening of the cord from the appliance;
  - 2) Breakage of the covering material or the seams of the covering;
  - 3) Breakage or loosening of any wiring connection;
  - 4) Appreciable shifting of the position of the heating pad within the appliance; or
  - 5) Breakage of a conductor of the heating element or other interruption of the electrical circuit through the appliance.

No Text on This Page

46.1.2 The minor flexing of small amplitude due to the compression of padding material during intended use of an appliance otherwise employing a rigid frame is not considered to be flexing as mentioned in 46.1.1.

46.1.3 Each of three complete samples of the appliance is to be flexed 8000 cycles under the conditions described in 46.1.4 – 46.2.4.

46.1.4 The apparatus for conducting the flexing test is to consist of a power-driven testing machine, a pair of wide clamps for gripping the edges of each sample, and a number of weights, each large enough to exert 1 pound of force (4.45 N) when suspended from a clamp.

46.1.5 The machine is to draw each sample back and forth by means of a clamp over the 1/2-inch (13-mm) radius edge of a smooth horizontal metal bed at a rate of approximately 15 cycles per minute. The stroke of the machine is to be adjustable to accommodate appliances of various dimensions, so that the greatest possible area of the heating pad is subjected to the flexing.

46.1.6 The clamps are to be in pairs that are long enough to accommodate edges of different dimensions, and may be of any construction that securely grips the edges of the appliance. One clamp is to be provided with hooks for the suspension of the weights. The clamps are to be applied to opposite edges of each sample, which is then to be adjusted in the machine with the weighted clamp hanging over the rounded edge of the bed. A weight exerting a force of 1 pound (4.45 N) is to be used for each 6 inches (152 mm) or fraction thereof of the edge of the appliance in the clamp.

46.1.7 Each sample is to be connected by means of its flexible cord and plug to a supply circuit. After 2000 cycles of continuous operation the machine is to be stopped, the pad turned 90 degrees so that the bending is at right angles to that previously made, and operation resumed. After the second 2000 cycles of operation the machine is to be stopped, the pad turned over, and operation resumed. After the third 2000 cycles of operation the machine is to be stopped, the pad turned again through 90 degrees, and the operation continued for a fourth 2000-cycle period.

## 46.2 Twisting

46.2.1 Each of three complete samples of an appliance shall be subjected to a 6000-cycle twisting test as described in 46.2.2 – 46.2.4 while connected to a supply circuit, with the heating pad switch in the high position. At the completion of the test, the appliance shall comply with the requirements in 46.1.1.

46.2.2 The apparatus for conducting the twisting test is to consist of a power-driven twisting machine and a pair of wide clamps for gripping the edges of each sample.

46.2.3 One end of the sample is to be rigidly clamped in a horizontal plane along its width. This end is to be prevented from twisting. The appliance is to be kept in tension by a pull of 5 pounds (22 N) that is placed on this end. The other end of the appliance is to be clamped in the twisting machine along its width.

46.2.4 The machine, with the sample clamped in place, is to twist back and forth through a 90 degree arc. The test is to be conducted at approximately 15 cycles per minute, a cycle being considered as the movement from the horizontal clockwise through 45 degrees of arc, counterclockwise through 90 degrees of arc to a position 45 degrees below the horizontal, and back to the horizontal. A faster twisting rate may be used with the concurrence of those concerned. See Figure 46.1.

**Figure 46.1**  
**Twisting-test apparatus**

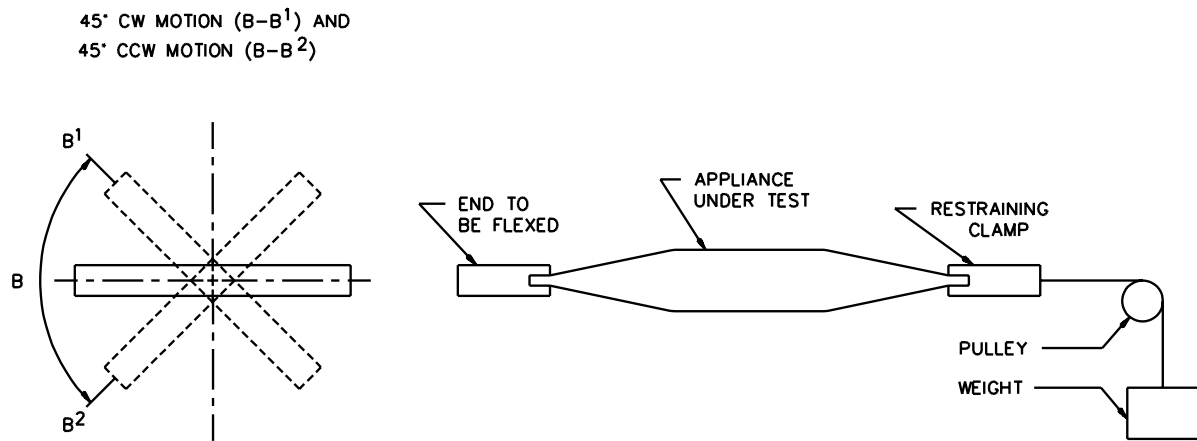

SB0560-1

## 47 Operational Test

47.1 Operation of an appliance as described in 47.2 shall not result in a risk of fire, electric shock, or injury to persons.

47.2 With reference to 47.1, an as-received sample of the appliance is to be set up or installed in accordance with the manufacturer's instructions. The sample is to be operated in accordance with the manufacturer's instructions with respect to the intended uses of the appliance, including maintenance and cleaning recommended by the manufacturer and lack of such maintenance and cleaning. All accessories recommended by the manufacturer for use with the appliance are to be tested. The appliance is to be manipulated as it would be in actual use, including manipulation of all controls and operation under the various loading conditions that can be expected. The appliance is to be operated for a sufficient length of time or through a sufficient number of cycles to determine that all reasonably foreseeable complications are revealed.

## 48 Abnormal-Operation Test

48.1 Short-circuiting either the rectifier or the capacitor of a combination consisting of a rectifier and an electrolytic capacitor shall not create a risk of fire, electric shock, or injury to persons.

## 49 Permanence of Marking Test

49.1 After being subjected to the conditions described in 49.2 – 49.6, a pressure sensitive label or a label secured by cement or adhesive is considered to be of a permanent nature if immediately following removal from each test medium and after being exposed to room temperature for 24 hours following removal from each medium:

- a) Each sample demonstrates good adhesion and the edges are not curled.
- b) The label resists defacement or removal as demonstrated by scraping across the test panel with a flat steel blade, held at right angles to the test panel.
- c) The printing is legible and is not defaced by rubbing with thumb or finger pressure.

49.2 OVEN-AGING TEST – Three samples of the label applied to test surfaces as in the intended application are to be conditioned for 24 hours in an oven maintained at the temperature specified in Table 49.1.

**Table 49.1**  
**Temperatures, oven-aging**

Maximum temperature during temperature test of surface to which applied		Oven temperature	
°C	°F	°C	°F
60 or less	140 or less	87	189
80 or less	176 or less	105	221
100 or less	212 or less	121	250
125 or less	257 or less	150	302
150 or less	302 or less	180	356
Over 150	Over 302	a	

<sup>a</sup> A label that is applied to a surface attaining a temperature greater than 150°C (302°F), during the temperature test, is to be oven-aged at a temperature representative of the temperatures attained by the appliance during normal and abnormal operation.

49.3 IMMERSION TEST – Three samples of the label applied to test surfaces as in the intended application are to be conditioned for 24 hours in a controlled atmosphere maintained at  $23 \pm 2^\circ\text{C}$  ( $73 \pm 4^\circ\text{F}$ ) with a  $50 \pm 5$  percent relative humidity. The samples are then to be immersed for 48 hours in water at a temperature of  $21 \pm 2^\circ\text{C}$  ( $70 \pm 4^\circ\text{F}$ ).

*Exception: In place of the immersion test, a label that is located within an enclosure and not subject to moisture during normal and abnormal operating conditions or routine cleaning may be conditioned for 72 hours in a controlled atmosphere maintained at  $32 \pm 2^\circ\text{C}$  ( $90 \pm 4^\circ\text{F}$ ) with a relative humidity of  $85 \pm 5$  percent.*

49.4 STANDARD-ATMOSPHERE TEST – Three samples of the label applied to test surfaces as in the intended application are to be conditioned for 72 hours in a controlled atmosphere maintained at  $23 \pm 2^{\circ}\text{C}$  ( $73 \pm 4^{\circ}\text{F}$ ) with a  $50 \pm 5$  percent relative humidity.

49.5 UNUSUAL-CONDITION EXPOSURE – If the labels are exposed to unusual conditions in service, such as oil, grease, cleaning solutions, or the like, three samples of the label applied to test surfaces as in the intended application are to be conditioned for 24 hours in a controlled atmosphere maintained at  $23 \pm 2^{\circ}\text{C}$  ( $73 \pm 4^{\circ}\text{F}$ ) with a  $50 \pm 5$  percent relative humidity. The samples are then to be immersed for 48 hours in a solution representative of service use maintained at the temperature the solution would attain in service but not less than  $23 \pm 2^{\circ}\text{C}$  ( $73 \pm 4^{\circ}\text{F}$ ).

49.6 OUTDOOR EXPOSURE TEST – If a label is intended to be exposed to the weather, three samples of the label applied to test surfaces as in the intended application are to be subjected for 720 hours to ultraviolet rays and water spray. The test cycle is to consist of exposure to ultraviolet rays for 17 minutes followed by exposure to ultraviolet light and a fine spray of water for 3 minutes.

## 49A Polymeric Enclosure Tests

### 49A.1 Mold stress-relief distortion

49A.1.1 Conditioning of an appliance as described in 49A.1.2 shall not result in softening of the material as determined by handling immediately after the conditioning; or shrinkage, warpage, or other distortion of the enclosure, determined after cooling to room temperature; that results in any of the following:

- a) Reduction of spacings between:
  - 1) Uninsulated live parts of opposite polarity;
  - 2) Uninsulated live parts and accessible noncurrent-carrying or grounded metal; or
  - 3) Uninsulated live parts and the enclosure less than the minimum values specified in Spacings, Section 23, and Spacings to Polymeric Enclosures, Section 23.11;
- b) Making uninsulated live parts or internal wiring accessible to contact as determined in accordance with Accessibility of Uninsulated Live Parts and Film-Coated Wire, Section 9;
- c) Non-compliance with Strain-Relief Test, Section 45; or
- d) Defeating the integrity of the enclosure so that mechanical protection in accordance with Frame and Enclosure, Section 5, and Enclosure and Guards, Section 26, is not afforded to internal parts of the appliance.

*Exception: This test is not required for rigid thermosetting materials.*

49A.1.1 added October 15, 1999

49A.1.2 The appliance is to be placed in a full-draft circulating-air oven maintained at a uniform temperature not less than  $10^{\circ}\text{C}$  ( $18^{\circ}\text{F}$ ) higher than the maximum temperature of the material measured under normal operating conditions, and not less than  $70^{\circ}\text{C}$  ( $158^{\circ}\text{F}$ ). The appliance is to remain in the oven for 7 hours. After careful removal from the oven and return to room temperature, the sample is to be examined for compliance with 49A.1.1.

49A.1.2 added October 15, 1999

## 49A.2 Impact

49A.2.1 An appliance enclosure shall withstand the impacts described in 49A.3.1 or 49A.4.1 as applicable, without resulting in any of the following:

- a) Reduction of spacings below the minimum specified in Spacings, Section 23, and Spacings to Polymeric Enclosures, Section 23.11;
- b) Accessibility of insulated or uninsulated live parts as determined in accordance with Accessibility of Uninsulated Live Parts and Film-Coated Wire, Section 9;
- c) An increase in the risk of injury to persons operating the appliance, see Enclosures and Guards, Section 26; or
- d) A risk of electric shock.

49A.2.1 added October 15, 1999

## 49A.3 Drop impact

49A.3.1 An appliance intended to be completely supported in the hand or by the body during use shall withstand being dropped three times on a hardwood floor from a height of 3 feet (914 mm). The appliance is to be dropped so it strikes the hardwood floor in a different position for each drop. The hardwood surface shall consist of a layer of nominal 2-inch (50.8-mm) wide tongue-and-groove oak flooring mounted on two layers of nominal 3/4-inch (19.1-mm) fir plywood. The oak flooring shall be 3/4 inch thick (nominal). The assembly is to rest on a concrete or equivalent nonresilient floor during the test.

49A.3.1 added October 15, 1999

## 49A.4 Ball impact

49A.4.1 A stationary, fixed, or floor-supported appliance shall withstand an impact of 5 foot-pounds (6.8 J) from a solid, smooth, steel sphere 2 inches (50.8 mm) in diameter and weighing approximately 1.18 pounds (0.5 kg) while the appliance is supported against, or on, a rigid surface that prevents the appliance from moving as a result of the impact. The impact is to be applied to any location considered exposed to a blow in normal use.

49A.4.1 added October 15, 1999

## 49A.5 Stain-relief after mold stress-relief distortion

49A.5.1 After the test sample has cooled to room temperature following the oven conditioning described in 49A.1.2, the sample shall comply with Strain-Relief Test, Section 45.

49A.5.1 added October 15, 1999

## 49A.6 Abnormal operation

49A.6.1 As a result of the test described in 49A.6.2, there shall not be ignition of polymeric enclosure parts or exposure of live parts. The material that the appliance is placed on, or draped with, shall not ignite as a result of emission of flame through other than existing openings.

49A.6.1 added October 15, 1999

49A.6.2 The appliance is to be operated under the conditions of abnormal operation, such as stalled-rotor operation, that the appliance is capable of producing. During the tests, the appliance is to rest on white tissue paper on a softwood surface. A single layer of cheesecloth is to be draped over the entire appliance and the appliance is to be operated continuously until ultimate results have been attained. In most cases, continuous operation for 7 hours is required to attain the ultimate results. The simulated abnormal conditions are to be imposed one at a time.

49A.6.2 added October 15, 1999

#### **49A.7 Crushing resistance**

49A.7.1 Stationary and fixed appliances shall withstand a 1-minute application of the crushing force described in 49A.7.2 without resulting in any of the following:

- a) Reduction of spacings below the minimum specified in Spacings, Section 23, and Spacings to Polymeric Enclosures, Section 23.11;
- b) Accessibility of insulated or uninsulated live parts as determined in accordance with Accessibility of Uninsulated Live Parts and Film-Coated Wire, Section 9;
- c) Breakage, cracking, rupture, or similar damage that adversely affects the insulation; or
- d) A risk of electric shock, fire, or injury to persons operating the appliance.

49A.7.1 added October 15, 1999

49A.7.2 Three samples of the appliance are to be backed on the mounting side by a fixed rigid supporting surface. A crushing force is to be applied to the side opposite the mounting surface. The force is to be applied through applicators having flat surfaces each 4 by 10 inch (102 by 254 mm). Each force applicator is to exert 100 pounds (45.4 kg) on the sample. As many applicators are to be applied as the sample can accommodate on the surface opposite the mounting surface, based on an arrangement of applicators as indicated in Figure 49A.1.

49A.7.2 added October 15, 1999

#### **49A.8 Thermal aging**

49A.8.1 A polymeric enclosure material shall be resistant to thermal degradation at the maximum temperature to which it is exposed during normal use. The thermal-aging characteristics of the material shall comply with one of the following:

- a) The material shall have a relative thermal index (RTI), based on historical data or a long-term thermal aging program, as described in the Standard for Polymeric Materials – Long Term Property Evaluations, UL 746B, that indicates that the material is rated for use at the temperature involved; or
- b) The maximum temperature to which the material is exposed during normal use of the appliance shall not exceed:
  - 1) 80°C (176°F) for a portable, attended, intermittent-duty household use appliance;
  - 2) 65°C (149°F) for any other portable appliance; or



- 3) 50°C (122°F) for all other appliances.

49A.8.1 added October 15, 1999

#### **49B Polymeric Materials Used as Structural Support**

49B.1 An appliance that employs a polymeric material for the structural support of a motor-driven part, a motor bearing, or similar part, including part or all of an enclosure, where deterioration or breakage results in excessive overload of the motor, is to be subjected to the conditioning described in 49A.1.2 and the impact tests specified in 49A.2.1. As a result of each test, the appliance shall not have an input current greater than 150 percent of the current measured during the applicable input test conducted on an unconditioned sample in accordance with Input Test, Section 36.

*Exception: This requirement does not apply to a polymeric material used for the support of bearings of a belt-driven part where stalling of the part does not result in stalling of the motor.*

49B.1 added October 15, 1999

#### **49C End-Product Arc Resistance**

49C.1 A polymeric material employed in accordance with Exception No. 2 to 12.3 is to be tested as described in 49C.3. There shall not be a permanent conductive carbon path as determined by application of the test in Dielectric Voltage-Withstand Test, Section 40, between the live part and the adjacent part of different potential indicated in 49C.3. There shall not be ignition:

- a) Within 15 arcs for materials classed V-0;
- b) Within 30 arcs for materials classed V-1 and V-2; or
- c) Within 60 arcs for materials classed HB.

49C.1 added October 15, 1999

49C.2 The flammability classes in 49C.1 are in accordance with the Standard for Tests for Flammability of Plastic Materials for Parts in Devices and Appliances, UL 94.

49C.2 added October 15, 1999

49C.3 The current for the arcing test is to be based upon the normal load-current rating and minimum power factor. The voltage used for the test is to be equal to the available voltage at the live part. The arc is to be established between the live part and any adjacent part where there is a potential for breakdown. The arc is to be used to attempt to ignite materials forming parts of the enclosure or to ignite materials located between the parts of different potential. The arc is to be established by means of a copper or stainless steel conductive probe. The conductive probe is to be used to create arc tracking or a carbon build-up across the surface of the insulating material. The rate is to be 30 arc separations per minute.

49C.3 added October 15, 1999

**Figure 49A.1**  
**Location of applicators for crush-resistance test**

Figure 49A.1 added October 15, 1999

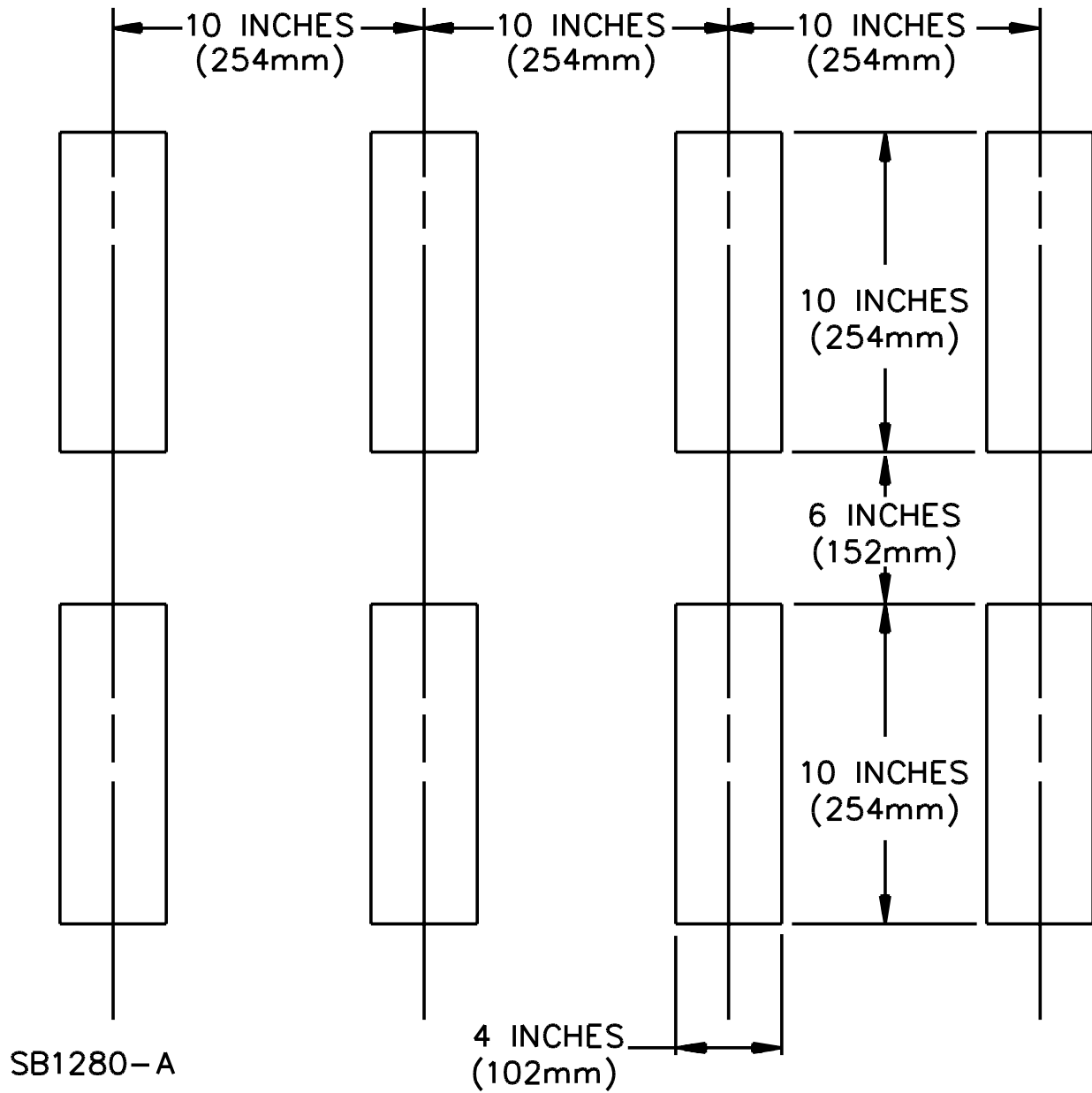

## 49D Abnormal Overload

49D.1 A polymeric material employed in accordance with Exception No. 3 to 12.3 shall withstand the temperatures attained during, or as a result of, passing abnormal currents through the parts that are in contact with, or within 1/32 inch (0.8 mm) of, the insulating material. There shall not be ignition, undue distortion, or melting of the material. The value of the abnormal current and the test time shall be as specified in Table 49D.1. See 49D.2 and 49D.3.

49D.1 added October 15, 1999

**Table 49D.1**  
**Abnormal overload test**

Table 49D.1 added October 15, 1999

Overcurrent protective device rating, amperes	Minimum test time <sup>a</sup>		
	110-percent current <sup>b</sup>	135-percent current	200-percent current
0 – 30	7 hours	60 minutes	2 minutes
31 – 60	7 hours	60 minutes	4 minutes

<sup>a</sup> When circuit conditions are such as to open a current carrying conductor without resulting in a risk of electric shock, fire, or injury to persons, the test circuit current is to be reduced to a point where the circuit remains intact for at least the time indicated and maximum heating is generated.

<sup>b</sup> Termination of the test when the temperatures have stabilized, indicating that ultimate results have been attained, meets the intent of the requirement.

49D.2 When no overcurrent protective device is provided as part of the equipment or when the overcurrent protective device is not rated for the application, compliance with 49D.1 shall be determined using percentages of the available energy to the appliance. The percentages are to be those specified in Table 49D.1 for the current rating of the intended branch-circuit overcurrent device for the appliance, and not less than a 30 ampere normal-acting protective device.

49D.2 added October 15, 1999

49D.3 When an overcurrent protective device is provided as part of the equipment, the device shall be relied upon only when the device is not user-serviceable or the risk of substitution of a device with a higher-rated value is reduced due to keying or other constructional features.

49D.3 added October 15, 1999

#### **49E Shiatsu-Type Massager Entrapment Test**

49E.1 With reference to Exception No. 2 to 26.7, a shiatsu-type massager with rotating massage heads that have less than 2 inches (50.8 mm) at any position of rotation shall be subjected to the test described in 49E.2 and 49E.3. As a result of the test, the probes shall not become trapped when applied to the space between the rotating heads of the massager. The material of the neoprene probes shall not catch, be pinched, or be jammed between the rotating heads during application of the probe.

Added 49E.1 effective April 15, 2001

49E.2 A neoprene probe with a diameter of 0.8 inches (9.5 mm), and a length of 4 inches (100 mm), and a neoprene probe with a diameter of 4 inches (100 mm) and a length of 6 inches (150 mm) is to be used for the test described in 49E.3. The probes are to have a hardness of 50 – 70 Durometer A, in accordance with Standard Test Method for Rubber-Property Durometer Hardness, ASTM D2240.

Added 49E.2 effective April 15, 2001

49E.3 One sample of the massager specified in 49E.1 is to be used for the test and shall be operated under intended operating conditions. The probes described in 49E.2 are to be applied one at a time to the space between rotating heads of the massager in all positions of rotation. The probes are to be applied using a pressure not greater than that required to maintain contact with the rotating heads.

Added 49E.3 effective April 15, 2001

### **MANUFACTURING AND PRODUCTION TESTS**

#### **50 Dielectric Voltage-Withstand Test**

50.1 Each appliance shall withstand without electrical breakdown, as a routine production-line test, the application of a 40 – 70 hertz potential between:

- a) The primary wiring, including connected components, and accessible dead metal parts that are likely to become energized, and
- b) Between primary wiring and accessible low-voltage metal parts, including terminals.

50.2 The production-line test shall be in accordance with either Condition A or Condition B of Table 50.1.

50.3 The appliance may be in a heated or unheated condition for the test.

**Table 50.1**  
**Production-line test conditions**

Appliance rating	Condition A		Condition B	
	Potential, volts	Time, seconds	Potential, volts	Time, seconds
With or without a motor rated 1/2 horsepower (373 W output) or less	1000	60	1200	1
Applied directly to persons	$1000+2V^a$	60	$1200+2.4V^a$	1
With a motor rated more than 1/2 horsepower	$1000+2V^a$	60	$1200+2.4V^a$	1
Applied in a wet or moist condition directly to persons	2500	60	3000	1
<sup>a</sup> Maximum rated voltage.				

50.4 The test is to be conducted when the appliance is complete – fully assembled. It is not intended that the appliance be unwired, modified, or disassembled for the test.

*Exception No. 1: Parts, such as snap covers or friction-fit knobs that would interfere with the performance of the test need not be in place.*

*Exception No. 2: The test may be performed before final assembly if the test represents that for the completed appliance.*

*Exception No. 3: The test may be conducted before a solid-state component that can be damaged by the dielectric potential is electrically connected. However, a random sampling of each day's production is to be tested at the potential specified in 50.2, but the circuitry may be rearranged for the test to minimize the likelihood of solid-state-component damage while retaining representative dielectric stress of the circuit.*

50.5 The test equipment shall include a transformer having an essentially sinusoidal output, a means of indicating the test potential, an audible or visual indicator of electrical breakdown, and either a manually reset device to restore the equipment after electrical breakdown or an automatic reject feature of any unacceptable unit.

50.6 If the output of the test-equipment transformer is less than 500 volt-amperes, the equipment shall include a voltmeter in the output circuit to directly indicate the test potential.

50.7 If the output of the test-equipment transformer is 500 volt-amperes or larger, the test potential may be indicated by:

- a) A voltmeter in the primary circuit or in a tertiary winding circuit,
- b) A selector switch marked to indicate the test potential, or
- c) A marking in a readily visible location to indicate the test potential of equipment having a single test potential output. If marking is used without an indicating voltmeter, the equipment shall include a positive means, such as a power-on lamp to indicate that the manually reset switch has been reset following a tripout.

50.8 Test equipment other than that described in 50.5 – 50.7 may be used if found to accomplish the intended factory control.

50.9 During the test, the primary switch is to be in the on position, both sides of the primary circuit of the product are to be connected together and to one terminal of the test equipment, and the second test-equipment terminal is to be connected to the accessible dead metal.

*Exception No. 1: An appliance (resistive, high-impedance winding, or the like) having circuitry not subject to excessive secondary-voltage build-up in case of electrical breakdown during the test may be tested with a single-pole primary switch, if used, in the off position or, with only one side of the primary circuit connected to the test equipment when the primary switch is in the on position, or when a primary switch is not used.*

*Exception No. 2: The primary switch is not required to be in the on position if the testing means applies full test potential between primary wiring and dead metal parts with the switch not in the on position.*

## **51 Grounding-Continuity Test**

51.1 Each appliance that has a power-supply cord having a grounding conductor shall be tested, as a routine production-line test, to determine that grounding continuity exists between the grounding blade of the attachment plug and the accessible dead metal parts of the appliance that are likely to become energized.

51.2 Only a single test need be conducted if the accessible metal selected is conductively connected by design to all other accessible metal.

51.3 Any acceptable indicating device, such as an ohmmeter, a battery-and-buzzer combination, or the like, shall be used to determine compliance with the grounding continuity requirement in 51.1.

## **RATING**

### **52 Details**

52.1 An appliance shall be rated in volts, in frequency (expressed in one of the following terms: hertz, Hz, cycles-per-second, cps, cycles/second, c/s, ac-dc, or ac only) and, other than as noted in 52.2, in amperes. The frequency may be expressed as \_\_\_/dc – for example, 60/dc – if a universal motor nameplate serves as the appliance rating marking.

52.2 Instead of the ampere rating mentioned in 52.1, an appliance shall be rated in watts if the full-load power factor is 0.80 or more or if the rating of a cord-connected appliance is 50 watts or less.

## MARKING

### 53 Details

#### 53.1 General

53.1.1 An appliance shall be plainly and permanently marked where it will be readily visible – after installation, in the case of a permanently connected appliance – with:

- a) The manufacturer's name, trade name, or trademark, or other descriptive marking by which the organization responsible for the product may be identified,

*Exception: When the product is identified by the brand or trademark owned by a private labeler, the manufacturer's identification by means of a traceable code meets the intent of the requirement.*

- b) A distinctive catalog number or the equivalent,
- c) The electrical rating, and
- d) The date or other dating period of manufacture not exceeding any three consecutive months.

*Exception: The date of manufacture in abbreviated form; in a nationally accepted conventional code, or in a code affirmed by the manufacturer meets the intent of the requirement when the code:*

*a) Does not repeat in less than 10 years for a household product or less than 20 years for a commercial product, and*

*b) Does not require reference to the production records of the manufacturer to determine when the product was manufactured.*

53.1.1 revised October 15, 1999

53.1.2 An appliance that employs a single motor as its only electric-energy-consuming component need not show the electrical rating given on the motor nameplate elsewhere on the appliance if this nameplate is readily visible after the motor has been installed in the appliance.

53.1.3 If the motor nameplate of a dual-voltage motor is employed to give the electrical rating of the appliance as provided in 53.1.2, the appliance shall be additionally and permanently marked to indicate the particular voltage for which it is connected when shipped from the factory. If the appliance employs an attachment plug, instructions shall be provided to indicate the type of plug that should be used if the appliance is reconnected for the alternate voltage. See 10.1.1.9.

53.1.4 If a manufacturer produces or assembles motor-operated appliances at more than one factory, each finished appliance shall have a distinctive permanent marking by means of which it may be identified as the product of a particular factory.

53.1.5 If the construction of an appliance contemplates cleaning or servicing, such as the replacement of pilot lamps or fuses, by the user, and if such cleaning or servicing would involve the exposure of a normally enclosed or protected live part to unintentional contact, the appliance shall be plainly and permanently marked to indicate that such servicing or cleaning be done with the appliance disconnected from the supply circuit.

53.1.6 An appliance that will not start and attain intended running speed when connected to a circuit protected by an ordinary – not a time-delay – fuse as described in 35.1 shall be plainly and permanently marked with the words "If connected to a circuit protected by fuses, use time-delay fuses with this appliance," or with an equivalent wording.

53.1.7 An appliance shall not be marked with a double insulation symbol – a square within a square, or the words "Double Insulation", or the equivalent unless it complies with the applicable requirements in the Standard for Double Insulation Systems for Use in Electrical Appliances, UL 1097.

## 53.2 Permanently connected appliances

53.2.1 If any point within a terminal box or wiring compartment of a permanently connected appliance in which the power-supply conductors are intended to be connected, including such conductors themselves, attains a temperature rise of more than 35°C (63°F) during the temperature test, the appliance shall be permanently marked "For supply connection, use wires acceptable for at least \_\_\_°C (\_\_\_°F)," or with an equivalent statement, and the temperature value shall be in accordance with Table 53.1. This statement shall be located at or near the point where the supply connections are to be made, and shall be clearly visible both during and after installation of the appliance.

**Table 53.1**  
**Outlet-box marking**

Temperature rise attained during test in terminal box or compartment		Temperature marking	
36 – 50°C	(64 – 90°F)	75°C	(167°F)
51 – 65°C	(91 – 117°F)	90°C	(194°F)



53.2.2 A permanently connected appliance having one motor and other loads or more than one motor with or without other loads shall be permanently marked in a location that will be visible when connections to the power-supply circuit are made and inspected with:

- a) The minimum supply-circuit conductor ampacity based on the maximum input in accordance with 36.1;
- b) The maximum rating of the supply-circuit overcurrent-protective device, which is not to exceed the rating of the fuse employed in the short-circuit test of the motor-overload-protective device employed in the appliance; and
- c) The type of supply-circuit overcurrent-protective device – for example, nontime delay fuse or dual-element time-delay fuse.

53.2.3 An appliance intended for permanent connection to a wiring system other than rigid metal conduit or armored cable shall be permanently marked to indicate the system or systems for which it is acceptable. The marking shall be located so that it will be visible when power-supply connections to the appliance are being made.

### 53.3 Components

53.3.1 A heating element rated more than 1 ampere and intended to be replaceable in the field shall be permanently marked with its rating in volts and amperes or in volts and watts, or the manufacturer's part number, or other means of identification.

53.3.2 An appliance that is intended to be controlled by or operated in conjunction with a capacitor/transformer unit shall be supplied with such capacitor or unit. A capacitor or a unit that is not physically a part of the appliance shall be permanently marked with an identification symbol. This symbol shall also appear on the nameplate of the motor.

### 53.4 Appliances with heating pads

53.4.1 An appliance employing a heating pad and constructed with a covering of cloth-backed vinyl, fabric, or other similar material shall be marked:

"WARNING

BURNS WILL RESULT FROM IMPROPER USE

READ INSTRUCTIONS BEFORE USING

DO NOT WET – DO NOT USE PINS

NEVER REMOVE COVER."

53.4.2 The marking specified in 53.4.1 shall be readily visible and permanent. It shall also be marked on such appliances as a heated vibrating chair, heated footstool vibrator, or the like. The lettering shall be in accordance with 31.4.

## INSTRUCTION MANUAL

### 54 General

54.1 An appliance shall be provided with legible instructions pertaining to:

- a) The risk of fire, electric shock, or injury to persons that may be associated with the use of the appliance,
- b) Operation,
- c) User-maintenance and storage, and, as applicable,
- d) Grounding or double-insulation.

54.2 The instructions shall indicate whether the appliance is intended for household or commercial use.

54.3 The instructions shall include the markings, or equivalent, specified in Section 31, Markings.

54.4 The text of all required instructions shall be in the words specified or words that are equivalent, clear, and understandable.

*Exception: If an appliance is such that the specified wording is unnecessary or conflicting, the wording may be omitted or modified, as appropriate.*

54.5 With reference to the requirement in 54.4, there shall be no substitute for the cautionary prefixes "DANGER" and "WARNING."

54.6 Instructions or illustrations shall be provided to identify important parts of the appliance, such as a stroke- or power-adjustment means or heat settings. An illustration may be used with a required instruction to clarify the intent, but shall not replace the written instruction.

54.7 Wording in parentheses in Sections 55 – 58 is explanatory, indicating options, alternatives, or cross-references. Wherever the word "appliance" is used, the name of the specific appliance may be substituted in the final text.

### 55 Instructions Pertaining to a Risk of Fire, Electric Shock, or Injury to Persons

55.1 Instructions pertaining to a risk of fire, electric shock, or injury to persons shall warn the user of reasonably foreseeable risks and state the precautions that should be taken to reduce such risks.

55.2 The instructions pertaining to a risk of fire, electric shock, or injury to persons shall be:

- a) In the first part of the manual,
- b) Before the operating instructions,
- c) Separate in format from other instructions related to assembly, operation, maintenance, and storage, and
- d) A permanent part of the manual.

55.3 The height of lettering in the text and illustrations of the instructions specified in 55.5 and 55.6 shall be as follows:

- a) Upper case letters – not less than 5/64 inch (1.9 mm);
- b) Lower case letters – not less than 1/16 inch (1.6 mm); and
- c) The statements required by 55.4, and cautionary prefixes, "DANGER" and "WARNING," required by 55.5 and 58.1 – not less than 3/16 inch (4.8 mm).

55.4 The statement "IMPORTANT SAFETY INSTRUCTIONS" or the equivalent shall precede the list of instructions required by 55.5 and 55.6, and the statement "SAVE THESE INSTRUCTIONS" or the equivalent shall either precede or follow the list.

55.5 The instructions required by 55.1 shall include the items in the following list, as applicable, and any other instructions that the manufacturer deems necessary for the appliance. The list shall not include the items mentioned in 54.2 or in Sections 56 – 58. The statement "Read all instructions before using" shall precede the list of items following the word "DANGER." The items may be numbered.

#### IMPORTANT SAFETY INSTRUCTIONS

When using an electrical appliance, basic precautions should always be followed, including the following:

Read all instructions before using (this appliance).

DANGER – To reduce the risk of electric shock:

- 1) Always unplug this appliance from the electrical outlet immediately after using and before cleaning.

WARNING – To reduce the risk of burns, fire, electric shock, or injury to persons:

- 1) An appliance should never be left unattended when plugged in. Unplug from outlet when not in use, and before putting on or taking off parts.
- 2) Do not operate under blanket or pillow. Excessive heating can occur and cause fire, electric shock, or injury to persons.

- 3) Close supervision is necessary when this appliance is used by, on, or near children, invalids, or disabled persons.
- 4) Use this appliance only for its intended use as described in this manual. Do not use attachments not recommended by the manufacturer.
- 5) Never operate this appliance if it has a damaged cord or plug, if it is not working properly, if it has been dropped or damaged, or dropped into water. Return the appliance to a service center for examination and repair.
- 6) Do not carry this appliance by supply cord or use cord as a handle.
- 7) Keep the cord away from heated surfaces.
- 8) Never operate the appliance with the air openings blocked. Keep the air openings free of lint, hair, and the like.
- 9) Never drop or insert any object into any opening.
- 10) Do not use outdoors.
- 11) Do not operate where aerosol (spray) products are being used or where oxygen is being administered.
- 12) To disconnect, turn all controls to the off position, then remove plug from outlet.

#### SAVE THESE INSTRUCTIONS

55.6 The following instructions shall be included in the list of items in addition to the items in 55.5 for the appliances indicated. If more than one item applies to the appliance, all applicable items for the appliance type shall be included.

a) Hand-Held or Hand-Supported Appliances –

- 1) The following items shall be included following the heading "DANGER."
  - i) Do not reach for an appliance that has fallen into water. Unplug immediately.
  - ii) Do not use while bathing or in a shower.
  - iii) Do not place or store appliance where it can fall or be pulled into a tub or sink. Do not place in or drop into water or other liquid.

- 2) The following item shall be added to (8) following the heading "WARNING:"
  - i) Never operate on a soft surface such as a bed or couch where the air openings may be blocked.
- b) Appliances with a heated surface other than those mentioned in (c) –
  - 1) The following item shall be included following the heading "WARNING:"
    - i) Use heated surfaces carefully. May cause serious burns. Do not use over insensitive skin areas or in the presence of poor circulation. The unattended use of heat by children or incapacitated persons may be dangerous.
- c) Appliances With Heating Pads –
  - 1) For an appliance employing a heating pad and constructed with a covering of cloth backed vinyl, fabric or other similar material, the following items shall be provided following the heading "DANGER:"
    - i) Never use pins or other metallic fasteners with this appliance.
    - ii) Carefully examine the covering before each use. Discard the appliance if the covering shows any sign of deterioration, such as checking, blistering, or cracking.
    - iii) Keep Dry – Do not operate in a wet or moist condition.
  - 2) The following items shall be added following the heading "WARNING:"
    - i) Temperatures sufficiently high to cause burns may occur regardless of the control setting. Do not use on an infant or invalid or on a sleeping or unconscious person. Do not use on insensitive skin or on a person with poor blood circulation. Check the skin in contact with the heated area of the appliance frequently to reduce the risk of blistering.
    - ii) Do Not Crush – Avoid sharp folds.
- d) Tub type foot massagers –
  - 1) The following item shall be included following the heading "WARNING:"
    - i) Do not stand on or in appliance. Use only while seated.
- e) Chairs, and the like, with movable parts such as foot supports –
  - 1) The following item shall be added to (3) of the list following the heading "WARNING:"
    - i) Keep children away from extended foot support (or other similar parts).

f. Grounded Products –

1) The following item shall be included following the heading "WARNING:"

i) Connect this appliance to a properly grounded outlet only. See Grounding Instructions.

## 56 Operating Instructions

56.1 Operating instructions shall include all information needed to operate the appliance as intended.

56.2 If an appliance having a dual-voltage motor is provided with an attachment plug, instructions shall be provided to indicate the type of plug that should be used if the appliance is reconnected for the alternate voltage.

56.3 An appliance provided with a 2-blade, polarized attachment plug shall be provided with the following instructions or the equivalent: To reduce the risk of electric shock, this appliance has a polarized plug (one blade is wider than the other). This plug will fit in a polarized outlet only one way. If the plug does not fit fully in the outlet, reverse the plug. If it still does not fit, contact a qualified electrician to install the proper outlet. Do not change the plug in any way.

## 57 User-Maintenance Instructions

57.1 User-maintenance instructions shall include:

a) Instructions for cleaning and user maintenance operations recommended by the manufacturer, such as lubrication or nonlubrication; and a statement to the user that any other servicing should be performed by an authorized service representative or that the appliance has no user serviceable parts.

b) Instructions for an appliance employing an automatically reset thermal limiter that shuts off the entire appliance shall inform the user what to expect if the thermal limiter operates.

c) Specific instructions for the proper method of storage of the cord, the total appliance, and the like, when the appliance is not in use; and for care of the cord while in use (for example, for a hand-supported product, untwisting).

d) In the case of an appliance intended to be used with water additives, conditioners, or other solutions with or without water, specific instructions regarding the proper liquid or additive to use and the amount to be used in conjunction with the appliance.

## 58 Grounding/Double Insulation Instructions

58.1 For a grounded appliance, the instructions shall include those instructions in (a) – (d) applicable to the appliance. For a double insulated appliance the instructions shall include (e).

- a) For all grounded, cord-connected products:

### GROUNDING INSTRUCTIONS

This product must be grounded. If it should malfunction or breakdown, grounding provides a path of least resistance for electric current to reduce the risk of electric shock. This product is equipped with a cord having an equipment-grounding conductor and a grounding plug. The plug must be plugged into an appropriate outlet that is properly installed and grounded in accordance with all local codes and ordinances.

**DANGER** – Improper connection of the equipment-grounding conductor can result in a risk of electric shock. Check with a qualified electrician or serviceman if you are in doubt as to whether the product is properly grounded. Do not modify the plug provided with the product – if it will not fit the outlet, have a proper outlet installed by a qualified electrician.

- b) For a grounded, cord-connected product rated less than 15 amperes and intended for use on a nominal 120-volt supply circuit, the instructions in either (1) or (2):

1) This product is for use on a nominal 120-volt circuit, and has a grounding plug that looks like the plug illustrated in sketch A in Figure 58.1. A temporary adapter that looks like the adapter illustrated in sketches B and C may be used to connect this plug to a 2-pole receptacle as shown in sketch B if a properly grounded outlet is not available. The temporary adapter should be used only until a properly grounded outlet (sketch A) can be installed by a qualified electrician. The green colored rigid ear, lug, or the like extending from the adapter must be connected to a permanent ground such as a properly grounded outlet box cover. Whenever the adapter is used, it must be held in place by a metal screw.

2) This product is for use on a nominal 120-volt circuit and has a grounding plug that looks like the plug illustrated in sketch A in Figure 58.1. Make sure that the product is connected to an outlet having the same configuration as the plug. No adapter should be used with this product.

- c) For all other grounded, cord-connected products:

This product is for use on a circuit having a nominal rating more than 120 volts (or "This product is rated more than 15 amperes and is for use on a circuit having a nominal rating of 120 volts") and is factory-equipped with a specific electric cord and plug to permit connection to a proper electric circuit. Make sure that the product is connected to an outlet having the same configuration as the plug. No adapter should be used with this product. If the product must be reconnected for use on a different type of electric circuit, the reconnection should be made by qualified service personnel.

- d) For a permanently connected product:

### GROUNDING INSTRUCTIONS

This product must be connected to a grounded metal, permanent wiring system; or an equipment-grounding conductor must be run with the circuit conductors and connected to the equipment-grounding terminal or lead on the product.

- e) For a double-insulated, cord-connected product:

### SERVICING OF DOUBLE-INSULATED PRODUCTS

In a double-insulated product, two systems of insulation are provided instead of grounding. No grounding means is provided on a double-insulated product, nor should a means for grounding be added to the product. Servicing a double-insulated product requires extreme care and knowledge of the system, and should be done only by qualified service personnel. Replacement parts for a double-insulated product must be identical to the parts they replace. A double-insulated product is marked with the words "DOUBLE INSULATION" or "DOUBLE INSULATED." The symbol (square within a square)



may also be marked on the product.

**Figure 58.1**  
**Grounding methods**

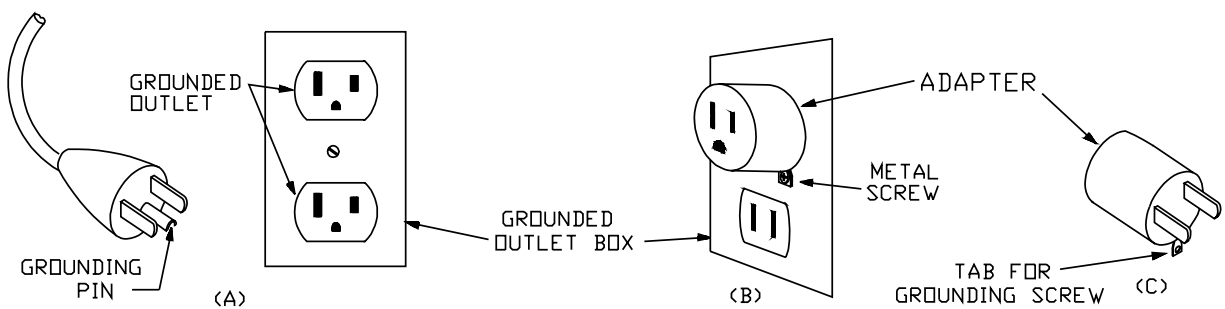

AA200



## APPENDIX A

### Standards for Components

Standards under which components of the products covered by this standard are evaluated include the following:

Title of Standard – UL Standard Designation

---

Attachment Plugs and Receptacles, Electric – UL 498  
Cord Sets and Power-Supply Cords – UL 817  
Fans, Electric – UL 507  
Filter Units, Air, Test Performance of – UL 900  
Flexible Cord and Fixture Wire – UL 62  
Fuseholders – UL 512  
Fuses for Supplementary Overcurrent Protection – UL 198G  
Lampholders, Edison-Base – UL 496  
Motors, Electric – UL 1004  
Motors, Overheating Protection for – UL 2111  
Plastic Materials for Parts in Devices and Appliances, Tests for Flammability of – UL 94  
Polymeric Materials – Use in Electrical Equipment Evaluations – UL 746C  
Printed-Wiring Boards, Electrical – UL 796  
Switches, Clock-Operated – UL 917  
Switches, Snap, General-Use – UL 20  
Switches, Special-Use – UL 1054  
Tape, Insulating – UL 510  
Temperature-Indicating and -Regulating Equipment – UL 873  
Thermal Cutoffs for Use in Electrical Appliances and Components – UL 1020  
Transformers, Specialty – UL 506  
Wire Connectors and Soldering Lugs for Use With Copper Conductors – UL 486A  
Wire Connectors for Use With Aluminum Conductors – UL 486B  
Wires and Cables, Rubber-Insulated – UL 44  
Wires and Cables, Thermoplastic-Insulated – UL 83

No Text on This Page

## CANADIAN REQUIREMENTS COMPARISON GUIDE CRG 1647

---

UL AND CANADIAN STANDARDS FOR MOTOR-OPERATED MASSAGE AND EXERCISE MACHINES

Product Category: Massage and Exercise Machines  
UL Category Control Number: PGXX7, PGXX8

UL Standard:

Standard for Motor-Operated Massage and Exercise Machines  
UL 1647  
Third Edition

Canadian Standard:

Motor-Operated Appliances (Household and Commercial)  
CAN/CSA-C22.2 No. 68-92  
Sixth Edition

This Canadian Requirement Comparison Guide is only intended to identify Canadian requirements that must be applied in addition to the requirements in the UL Standard to obtain a c-UL Mark. The guide is not intended to replace a thorough review and comparison of the requirements applicable to the product category as contained in the applicable UL and Canadian Standards. Where requirements are not specifically addressed, compliance with the requirements in the UL Standard satisfy the requirements in the Canadian Standard.

The actual requirements applied for a c-UL product investigation may differ from those identified in this guide based on the specific features, characteristics, components, materials, or systems used in the product.

CRG: 1647

Issue No.: 1

Issue Date: July 7, 1998

Revisions of this guide will be made by issuing revised or additional pages bearing their date of issue. A Canadian Requirement Comparison Guide is current only if it incorporates the most recently adopted revisions, all of which are itemized on the transmittal notice that accompanies the latest set of revision pages for the Guide.

The following outlines the requirements contained in CSA C22.2 No. 68-92 that are in addition to the requirements in UL 1647 that must be met in order for a product to bear the appropriate UL Marking. UL provides a certification program for products that meet the Canadian requirements. The c-UL Mark provides assurance that the product, as evaluated by UL, complies with the appropriate Canadian requirements.

<u>Requirements Topics</u>	<u>CSA Clause</u>	<u>Comparison</u>
<b>Construction:</b>		
Components	4.1.1	Electrical components shall comply with the applicable CSA Standards.
Physical Abuse	4.1.2, 4.2.1	All appliances, including metal enclosures, shall be subjected to physical abuse tests in Clause 6.12.
Backflow Prevention	4.1.4.2, 4.1.4.3	Products connected to potable water must be provided with backflow prevention.
<b>Enclosures:</b>		
Supply Cord Material	4.2.3	Enclosure requirements are reduced if supply cord material is correctly employed in the product.
Liquid Containers	4.2.4	Overfill and Tip Over Tests are required for products with liquid containers.
Non-Metallic Enclosures	4.2.5(b)	Non-metallic enclosures for live parts shall not be in contact with incandescent lamps.
Enclosures of Unattended Appliances	4.2.6.1	The enclosure for an unattended appliance, that is still under power, shall have an enclosure material that complies with C22.2 No. 0.6, Flame Test A or J.
	4.2.6.2	Exception to Clause 4.2.6.1 allowing compliance with Flame Test E of C22.2 No. 0.6 with component considerations, and when the enclosure material has a UL High Amp Arc Ignition (HAI), PLC of 0 or 1.
Enclosures of Attended Appliances	4.2.7	Except as permitted by Clauses 4.2.6.2 and 4.2.8, appliances that are attended in normal use shall comply with Test D of CSA C22.2 No. 0.6 and acceptance criteria specified in Clause 6.20.2.

## Table Continued

<u>Requirements Topics</u>	<u>CSA Clause</u>	<u>Comparison</u>
Appliance Enclosures	4.2.8	Enclosure of appliances that have momentary contact switches or are intended to be hand-held during operation shall comply with Test E of CSA C22.2 No. 0.6 as specified in Clause 6.20.3.
Openings in Enclosures	4.2.13.1	Openings in all appliances except hand-held types, and underneath motors that comply with CSA C22.2 No. 77, shall not be located directly below terminals, heater elements, wiring (including insulated conductors), and other live parts unless they are baffled or screened to prevent molten metal or burning material from falling on the supported surface. This requirement does not apply to wiring supplied from Class 2 transformer that complies with CSA C22.2 No. 66.
	4.2.13.5	Employing a screen or perforated metal panel is acceptable in preventing molten metal or burning material from falling on the supporting surface, as required by Clause 4.2.13.1.
<b>Mechanical Assembly:</b>		
Security from Vibration	4.4.1	Wire connectors shall be taped unless applied by a compression tool or a machine.
Fastening	4.4.2	Lockwashers shall not be used to prevent rotation of the body of rotary switches or field wiring terminals.
<b>Cord-Connected Appliances and Power-Supply Cords:</b>		
	4.5.2.2	Appliances with a cord set or permanently attached power-supply cord shall have an attachment plug with a current rating of 125% of the product operating more than one hour and it shall comply with C22.2 No. 42.

## Table Continued

<u>Requirements Topics</u>	<u>CSA Clause</u>	<u>Comparison</u>
Flexible Cords and Cables	4.5.2.3	Flexible cords and cables used as power-supply cords and cord sets shall comply with CSA C22.2 No. 21 and 49.
Power-Supply Cord Types	4.5.2.6	Household hand-held products rated over 0.5 amps shall employ Type SPT-1 cord minimum. Commercial hand-held products rated more than 0.5 amps shall employ Type SV cord minimum.
<b>Wiring:</b>		
Internal Wire Types	4.8.6.1	Specified Types TEW, GTF, SEWF-1, SEW-1, TR, or equivalent in accordance with C22.2 No. 127.
<b>Motors:</b>		
Overheating Protection	4.10.2	<p>All motors shall have inherent overheating protection in accordance with the requirements of CSA C22.2 No. 77, except in the following:</p> <ul style="list-style-type: none"> <li>a) an appliance having overload protection</li> <li>b) a permanently connected commercial appliance which can be readily protected against overload at the time of installation and is marked in accordance with Clause 5.20</li> <li>c) an appliance having a momentary contact switch</li> <li>d) an appliance that is hand-held during its intended use</li> <li>e) an attended intermittent-duty household appliance that complies with the Abnormal Test</li> <li>f) an attended intermittent-duty household appliance incorporating an optional one-shot fusible device.</li> </ul>

## Table Continued

<u>Requirements Topics</u>	<u>CSA Clause</u>	<u>Comparison</u>
<b>Protective Devices and Fuseholders:</b>		
Overcurrent Protective Device	4.14.2	For extractor-type fuseholders, the end cap shall be connected toward the load.
<b>Spacings:</b>		
General	4.16.1 and Table 4	Specify larger spacing requirements.
<b>Bonding and Grounding:</b>		
General	4.18.1, 4.18.2	Requires grounding or double insulation on all products except: <ul style="list-style-type: none"> <li>a) exposed metal parts that are not likely to become energized and the equipment complies with the requirements of Clause 7.6; or</li> <li>b) cord-connected household equipment that is hand-held or table-mounted and is neither connected to the water supply or drainage during use nor intended to be immersed partially or entirely for cleaning.</li> </ul>
<b>Printed Circuit Boards:</b>		
Class 2 Circuits	4.22.1, 4.22.2	Printed wiring boards shall be rated V-1 minimum.
Motorized Chairs, Beds, and Exercise Appliances	4.23	Motorized chairs, beds, and exercise appliances that have moving parts, shall be subjected to entrapment tests of Clause 4.23.2 or provided with child-safe controls described in Clause 4.23.3.
<b>Marking:</b>		
General	5.1	Date of manufacture shall be month and year.



## Table Continued

<u>Requirements Topics</u>	<u>CSA Clause</u>	<u>Comparison</u>
	5.2	Requires marking to meet C22.2 No. 0.
Non-Time Delay Equipment	5.11	Equipment that needs "time delay" fuses as described in Clause 6.3 shall be plainly marked with the words: <b>IF CONNECTED TO A CIRCUIT PROTECTED BY FUSES, USE TIME-DELAY FUSE MARKED D.</b>
Motorized Exercise Appliances	5.21	As required by Clause 4.23.3, the control unit of an appliance shall be marked with a readily visible warning as follows, or equivalent wording: <b>WARNING: REMOVE CONTROL BOX (OR KEY, OR SAFETY PIN, AS APPLICABLE), WHEN NOT IN USE AND STORE OUT OF REACH OF CHILDREN.</b>
Rating	6.4	The input to the equipment in amperes or watts shall be within 85 to 110% of the marked rating. Equipment rated less than 3 A or 300 W input shall be within 80 to 120% of the marked rating and the indicated horsepower within 70 to 130% of the marked rating. The shaft output horsepower of motors, when provided, shall be within 80 to 120% of the marked horsepower rating.
Tests at Over and Undervoltage	6.5.2	Equipment shall also meet the temperature requirements of Clause 6.5.1 when tested at the extreme operating voltages of the supply systems (see CSA CAN3-C23.5; eg. 120V at 104 and 127V) with an additional allowance of 20°C above the specified insulation temperature.
Dielectric Withstand Test	6.6	A potential of 2500 V is used for non-grounded products rated 31-250 V that are applied directly to persons.
Temperature (Abnormal)	6.7	Abnormal testing requirements for appliances.

## Table Continued

<u>Requirements Topics</u>	<u>CSA Clause</u>	<u>Comparison</u>
Test Conditions for Hazards	6.7.3	The Abnormal Test shall be conducted with 4 layers of cheesecloth. Five samples shall be tested if the appliance is constructed in accordance with Clause 4.10.2. The leakage current shall be measured throughout the test.
Dielectric Strength Test	6.7.4	A Dielectric Strength Test shall be conducted after the abnormal test.
Hand-held Appliances	6.7.8(a)	An additional Abnormal Test conducted for hand-held appliances – 10 cycles shall be 15 sec. "on" and 15 sec. "off."
Leakage Current Test	6.10.1	Limits maximum leakage current to 0.5 mA under all conditions.
Physical Abuse	6.12.1	Requires 2.03 J ball impact on all enclosures except enclosures of hand-held appliances.
Shock Hazards	6.12.3	Leakage Current Test shall be repeated and a spacing check with the 1/4 in. probe shall be conducted after impact and drop tests.
Strain Relief	6.13.1	In addition to the Strain Relief Test, a Torque Test shall also be conducted on the attachment cord.
Flexing	6.13.2	Attachment cords flexed during normal use shall be subjected to a 5000-cycle flexing test, followed by a repeated strain relief test.
Cord Set Retention	6.13.3	A detachable cord set shall be subjected to a 1000-cycle insertion/withdrawal test.
Speed Control, Limit Short Test	6.14	All speed controls shall be tested at four times the rating of the motor.

**Table Continued**

<b><u>Requirements Topics</u></b>	<b><u>CSA Clause</u></b>	<b><u>Comparison</u></b>
Perforated Metal Panels or Wire Screens, Flaming Oil Test	6.16	Perforated metal panels or wire screens with openings larger than required by Clause 4.2.13.5 shall be subjected to this test.
Hydrostatic Strength – Pressure Vessel and System Parts	6.17	All parts subjected to pressures higher than 15 psi are either “CRN” certified or subjected to 2-1/2 time Hydrostatic Pressure Test.
Motorized Chairs, Beds, and Exercise Equipment	6.21.3	Entrapment hazards are determined by neoprene test probe and head form.
Deflection Test	6.21.4	A force of 110 N is used to evaluate the strength of enclosures of moving parts.
Motion Test	6.21.5	Stop, start, and reversing capabilities are checked at different positions to determine casualty hazards.
Power Failure	6.21.6	Power is removed while the lift is extended to determine if there is more than 6.3-mm movement.

No Text on This Page

**Superseded requirements for  
the Standard for  
Motor-Operated Massage and Exercise Machines**

**UL 1647, Third Edition**

The requirements shown are the current requirements that have been superseded by requirements in revisions issued for this standard. To retain the current requirements, do not discard the following requirements until the future effective dates are reached.

5.14.3 A polymeric material used for parts, other than mentioned in 5.14.1 or 5.14.2, having a volume greater than 0.122inch<sup>3</sup>(2 cm<sup>3</sup>) shall be classified HB minimum.

26.7 The rotating massage heads of a shiatsu-type massager shall be such that the distance between the heads is 2 inches (50.8 mm) or more at any position of rotation.

*Exception: A distance between the heads less than 2 inches (50.8 mm) is capable fo being used when a guard is provided that restricts access to the massage heads. The guard shall extend above the plane of the point where the heads come closest together.*

No Text on This Page