



UL1005

ISBN 0-7629-0731-2

**Underwriter's laboratories Inc.**  
**Standard for safety**

**Electric flatirons**



a century of public safety  
established 1894



**Underwriters laboratories inc.®**

Northbrook, Illinois. (847) 272-8800

Melville, New York. (631) 271-6200

Santa Clara, California. (408) 985-2400

Research Triangle Park,

North Carolina. (919) 549-1400

Camas, Washington. (360) 817-5500

Underwriters' laboratories, inc., founded in 1894, is chartered as a not-for-profit organization without capital stock, under the laws of the state of Delaware, to establish, maintain, and operate laboratories for the examination and testing of devices, systems and materials to determine their relation to hazards to life and property, and to ascertain, define and publish standards, classifications and specifications for materials, devices, products, equipment, constructions, methods, and systems affecting such hazards.

UL standards for safety are developed under a procedure, which provides for participation and comment from the affected public as well as industry. The procedure takes into consideration a survey of known existing standards and the needs and opinions of a wide variety of interests concerned with the subject matter of the standard. Thus manufacturers, consumers, individuals associated with consumer-oriented organizations, academicians, government officials, industrial and commercial users, inspection authorities, insurance interests and other provide input to UL in the formulating of UL standards for safety, to keep them consonant with social and technological advances.

A not-for-profit organization

Dedicated to public safety and

Underwriter's laboratories inc. (UL)  
 333pfingsten road  
 Northbrook, IL 60062-2096

UL standard for safety for electric flatirons, UL 1005

Fourth edition, dated July 2,2002

Revisions: this standard contains revisions though and including February 18,2004.

### **Summary of topics**

**The revisions dated February 18, 2004 were issued to incorporate the following revised requirement:**

- Revision of paragraph 12.1.2.10 to delete" natural" from the term "natural gray".
- Revision of paragraph 27.1.1 and 27.1.3 to require the water reservoir of a steam iron be filled to maximum "fill" level during the drop test.
- Revision of paragraphs 43.4.1and 43.4.2 to clarify that, after the endurance test, the water reservoir is filled to determine evidence of deterioration.

Text that has been changed in any manner is marked with a vertical line in the margin. Changes in Requirements are marked with a vertical line in the margin and are followed by an effective date note indicating the date of publication or the date on which the changed requirement becomes effective.

The following table lists the future effective dates with the corresponding item.

| Future effective date | References       |
|-----------------------|------------------|
| August 18,2005        | 27.1.1and 27.1.3 |

The revised requirements are substantially in accordance with UL's bulletin(s) on this subject dated July 8,2003 and December 22,2003. The bulletin(s)is now obsolete and may be discarded.

The revisions dated February 15,2004 include a reprinted title page (page1) for this standard.

As indicated on the title page (page1), this UL standard for safety is an American national standard. Attention is directed to the note on the title page of this standard outlining the procedure to be followed to retain the approved text of this ANSI/UL standard.

The master for standard at UL's Northbrook office is the official document insofar as it relates to a UL service and the compliance of a product with respect to the requirements for that product and service, or if there are questions regarding the accuracy of this Standard.

UL's standards for safety are copyrighted by UL. Neither a printed copy of a Standard, nor the distribution diskette for a Standard-on-Diskette and the file for the standard on the distribution diskette should be altered in any way. All of UL's standards and all copyrights, ownerships, and rights regarding those Standards shall remain the sole and exclusive property of UL.

All rights reserved. No part of this publication may be reproduced, stored in a retrieval system, or transmitted in any form by any means, electronic, mechanical photocopying, recording, or otherwise without prior permission of UL.

Revisions of UL Standards for safety are issued from time to time. A UL standard for safety is current only if it incorporates the most recently adopted revisions.

UL provides this Standard "as is" without warranty of any kind, either expressed or implied. Including but not limited to, the implied warranties of merchantability or fitness for any purpose.

In no event will UL be liable for any special, incidental, consequential, indirect or similar damages, including loss of profits, lost savings, loss of data, or any other damages arising out of the use of or the inability to use this standard, even if UL or an authorized UL representative has been advised of the possibility of such damage, in no event shall UL'S liability for any damage ever exceed the price paid for this standard, regardless of the form of claim.

UL will attempt to answer support requests concerning electronic versions of its Standards. However, this support service is offered on a reasonable efforts basis only, and UL may not be able to resolve every support request. UL support the electronic versions of its standard only if they are used under the conditions and operating systems for which it is intended. UL's support policies may change from time-to-time without notification.

UL reserves the right to change the format, presentation, file types and formats, delivery methods and formats, and the like of both its printed and electronic standard s without prior notice.

Purchasers of the electronic versions of UL's standards for safety agree to defend, indemnify, and hold UL harmless from and against any loss, expense, liability, damaged, claim, or judgment (including reasonable attorney's fees) resulting from any error or deviation introduced while purchaser is storing an electronic standard on the purchaser's computer system.

If a single-user version electronic standard was purchased; one copy of this standard may be stored on the hard disk of a single personal computer, or on a single LAN file-server or the permanent storage device of a multiple-user computer in such a manner that this Standard may only accessed by one user at a time and for which there is no possibility of multiple concurrent access.

If a multiple-user version electronic standard was purchased, one copy of the standard may be stored on a single LAN file-server, or on permanent storage device of a multiple-user computer, or on an intranet server. The number of concurrent user shall not exceed the number of users authorized.

Electronic Standards are intended for on-line use, such as for viewing the requirements of a standard, conducting a word search, and the like. Only one copy of the standard may be printed from each single-user of version of an electronic standard. Only one copy of the standard may be printed for each authorized user of a multiple-user version of electronic standards. Because of differences in the computer/software /printer setup used by UL and those of electronic standards purchasers, the printed copy obtained by a purchaser may not look exactly like the on -line screen view or the printed standard.

An employed of an organization purchasing a UL standard can make a copy of the page or pages being viewed for their own fair and/or practical internal use.

The requirements in this standard are now in effect, except for those paragraphs, sections, tables, figures, and/or other elements f the standard having future effective dates as indicted in the note following the affected item. The prior text for requirements that have been revised and that have a future effective date are located after the standard, and are preceded by a "SUPERSEDED REQUIREMENTS" notice.

New product submittals made prior to a specified future effective date will be judged under all of the requirements in this standard including those requirements with a specified future effective date, unless the applicant specifically requests that the product be judged under the current requirements. However, if the applicant elects this option, it should be noted that compliance with all the requirements in this Standard will be required as a condition of continued listing, and follow-up services after the effective date, and understanding of this should be signified in writing.

copyright@2004 underwriters laboratories inc.

This standard consists of pages dated as shown in the following checklist:

| Page           | date             |
|----------------|------------------|
| 1.....         | February 18,2004 |
| 2.....         | July 02,2002     |
| 3-6.....       | February 18,2004 |
| 7-8.....       | July 02, 2002    |
| 9-10.....      | February 18,2004 |
| 11-14.....     | July 02, 2002    |
| 15-16B.....    | February 18,2004 |
| 17-29.....     | July 02, 2002    |
| 30.....        | February 18,2004 |
| 31.....        | July 02, 2002    |
| 32.....        | February 18,2004 |
| 33.....        | July 02, 2002    |
| 34-34B.....    | February 18,2004 |
| 35-41.....     | July 02, 2002    |
| 42.....        | February 18,2004 |
| 43-49.....     | July 02, 2002    |
| 50.....        | February 18,2004 |
| 51-55.....     | July 02, 2002    |
| 56-56B.....    | February 18,2004 |
| 57-62.....     | July 02, 2002    |
| A1.....        | February 18,2004 |
| A2.....        | July 02, 2002    |
| CRG1-CRG3..... | July 02, 2002    |
| CRG4.....      | February 18,2004 |
| SR1-SR2.....   | February 18,2004 |

No text on this page



July 2,2002

(Title page reprinted: February 18,2004)

**1**

## **UL1005**

### **Standard for electric flatiron**

First edition – February 1977  
Second edition – October 1979  
Third edition – April 1993

### **Fourth edition**

**July 2,2002**

The most recent designation of ANSI/UL 1005 as an American national standard (ANSI) occurred on January 28,2004. The ANSI approval for this standard does not include the Cover Page, Transmittal Page, Title Page, Foreword, Appendices, Canadian Comparison Guide (CRG), or Superseded Requirements.

This ANSI/UL standard for safety, which consists of the fourth edition with revisions through February 18, 2004 is under continuous maintenance, whereby each revision is ANSI approved upon publication. Comments or proposals for revisions on any part of the standard may be submitted to UL at any time. Written comments are to be sent to the UL Northbrook standards department, 333 Pfingsten roads, Northbrook IL 60062.

An effective date included as a note immediately following certain requirements is one established by Underwriter Laboratory Inc.

Revisions of this standard will be made by issuing revised or additional pages bearing their date of issue. A UL standard is current only if it incorporates the most recently adopted revised, all of which are itemized on the transmittal notice that accompanies the latest set of revised requirements.

**ISBN 0-7629-0731-2**

**COPYRIGHT@ 1977, 2004 UNDERWRITERS LABORATORIES INC.**

No text on this page



**CONTENTS**

|  |    |
|--|----|
| <b>FOREWORD</b> .....                          | 6  |
| <b>INTRODUCTION</b>                            |    |
| 1 Scope .....                                  | 7  |
| 2 Glossary .....                               | 7  |
| 3 Components .....                             | 7  |
| 4 Units of measurement .....                   | 8  |
| 5 References .....                             | 8  |
| <b>CONSTRUCTION</b>                            |    |
| 6 General.....                                 | 8  |
| 7 Frame and enclosure .....                    | 8  |
| 8 Mechanical assemblies .....                  | 12 |
| 9 Stands .....                                 | 12 |
| 10 Handles .....                               | 13 |
| 11 Protections against corrosion.....          | 13 |
| 12 Supply-connected flatirons.....             | 13 |
| 12.1 permanently connected flatirons .....     | 13 |
| 12.2 Cord –connected flatirons .....           | 16 |
| 12.3 Cordless flatirons.....                   | 20 |
| 13 Current –carrying parts.....                | 20 |
| 14 Internal wiring .....                       | 20 |
| 14.1 General.....                              | 20 |
| 14.2 Splices.....                              | 21 |
| 15 Electrical insulation.....                  | 21 |
| 16 Thermal insulation .....                    | 22 |
| 17 Switches and controls .....                 | 22 |
| 17.1 General.....                              | 22 |
| 17.2 Backup protective devices .....           | 22 |
| 18 Spacing.....                                | 23 |
| 19 Barriers .....                              | 24 |
| 20 Grounding.....                              | 25 |
| 21 Parts subject pressure.....                 | 26 |
| 21.1 General.....                              | 26 |
| 21.2 Pressure relief devices.....              | 27 |
| 22 Indicator lights .....                      | 28 |
| <b>PERFORMANCE</b>                             |    |
| 23 General.....                                | 28 |
| 24 Leakage current test.....                   | 29 |
| 25 Power input test.....                       | 32 |
| 26 Soleplate temperature test .....            | 32 |
| 27 Mechanical abuse test.....                  | 34 |
| 27.1 Flatirons.....                            | 34 |
| 27.2 Power stands for cordless flatirons ..... | 35 |
| 28 Temperatures-control endurance test .....   | 38 |
| 29 Normal temperature test .....               | 38 |

|  |   |      |
|--|---|------|
| 29.1   | General.....  | 38   |
| 29.2   | Procedure.....  | 40   |
| 29.3   | Parts near handle .....                                 | 42   |
| 29.4   | Wire and cord.....                                      | 43   |
| 29.5   | Surface temperature .....                               | 44   |
| 30   | Dielectric voltage – withstand test.....                | 44   |
| 31   | Test for security of blades on cordless flatirons ..... | 44   |
| 32   | Overload test.....                                      | 45   |
|  | 32.1 Automatic flatirons.....                           | 45   |
|  | 32.2 Cordless flatirons.....                            | 45   |
| 33   | Endurance test for cordless flatirons.....              | 46   |
| 34   | Resistance to moisture test.....                        | 46   |
| 35   | Tests on automatic reset controls.....                  | 46   |
| 36   | Tests on indicator lights .....                         | 47   |
| 37   | Abnormal operation test .....                           | 47   |
|  | 37.1 Overfill .....                                     | 47   |
|  | 37.2 Overtemperature .....                              | 47   |
|  | 37.3 Dual voltage appliance.....                        | 48   |
|  | 37.4 Components .....                                   | 49   |
| 38   | Stability test .....                                    | 49   |
| 39   | Cord flexing .....                                      | 50   |
| 40   | Strain relief test.....                                 | 51   |
| 41   | Push-back relief test.....                              | 52   |
| 42   | Permanence of marking .....                             | 52   |
| 43   | Polymeric material tests .....                          | 53   |
|  | 43.1 General.....                                       | 53   |
|  | 43.2 mold- stress evaluation .....                      | 54   |
|  | 43.3 Flame resistance .....                             | 55   |
|  | 43.4 endurance .....                                    | 56   |
| <b>MANUFACTURING AND PRODUCTION TESTS</b>              |   |      |
| 44   | Dielectric voltage – withstand test.....                | 57   |
| 45   | Grounding Continuity Test.....                          | 58   |
| <b>RATING</b>  |   |      |
| 46   | General.....  | 59   |
| <b>MARKING</b>   |   |      |
| 47   | General.....  | 59   |
| 48   | Instruction Manual.....                                 | 61   |
| <b>APPENDIX A</b>                                      |   |      |
|  | Standards for Components .....                          | A1   |
| <b>CANADIAN REQUIREMENTS COMPARISON GUIDE CRG 1005</b> |   |      |
|  | UL AND CANDIAN STANDARDS FOR ELECTRIC FLATIRONS .....   | CRG1 |

No text on this page

## FOREWORD

A. This standard contains basic requirements for products covered by underwriter's laboratories Inc. (ul) under its follow-up service for this category within the limitations given below and in the scope section of this Standard. These requirements are based upon sound engineering principles, research, records of tests and field experience, and an appreciation of the problems of manufacture, installation, and use derived from consultation with and information obtained from manufacturers, users, inspection authorities and others having specialized experience. They are subject to revision as further experience and investigation may show is necessary or desirable.

B. The observance of the requirements of this standard by a manufacturer is one of the conditions of the continued coverage of the manufacturer's product.

C. A product which complies with the text of this standard will not necessarily be judged to comply with the standard if, when examined and tested, it is found to have other features which impair the level of safety contemplated of these requirements.

D. A product employing materials or having forms of construction which conflict with specific requirements of the Standard cannot be judged to comply with the Standard. A product employing materials or having forms of construction not addressed by this standard may be examined and tested according to the intent of the requirements and, if found to meet the intent of this Standard, may be judged to comply with the Standard.

E. UL, in performing its functions in accordance with its objective, does not assume or undertake to discharge any responsibility of the manufacture or any other party. The opinions and findings of UL represent its professional judgment given with due consideration to the necessary limitations of practical operation and state of the art at the time the standard is processed. UL shall not be responsible to anyone for the use of or reliance upon this standard by anyone. UL shall not incur any obligations or liability for damages, including consequential damages, arising out of in connection with the use, interpretation of, or reliance upon this standard.

F. Many tests required by the standard of UL are inherently hazardous and adequate safeguards for personnel and property shall be employed in conducting such tests.

## INTRODUCTION

### 1 Scope

1.1 These requirements cover household electric flatirons and cordless flatirons rated 250v or less and commercial electric flatirons rated 600v or less, to be employed in accordance with the National Electrical Code, NFPA 70.

1.2 These requirements do not cover ironing machines, ironing presses, or other garment finishing appliance that are covered by the standard for garment finishing appliances, UL141.

### 2 Glossary

2.1 For the purpose of this standard the following definitions apply.

2.2 AUTOMATIC FLATIRON—a flatiron having some form of automatic temperature control, usually a thermostatic control that operates automatically within predetermined temperature limits to open and close the circuit through the heating element.

2.3 CORDLESS FLATIRON—a flatiron intended to be operated while it is disconnected from the power supply.

### 3 Components

3.1 Except as indicated in 3.2,a component of a product covered by this standard should comply with the requirements for that component. See appendix A for a list of standards covering components generally used in products covered by this standard.

3.2 A component is not required to comply with a specific requirement that:

- a) Involves a feature or characteristic not required in the application of the component in the product covered by this standard, or
- b) Is superseded by a requirement in this standard.

3.3 A component shall be used in accordance with its rating established for the intended conditions of use.

3.4 specific components are incomplete in construction features or restricted in performance capabilities. Such components are intended for use only under limited conditions, such as certain temperatures not exceeding specified limited, and shall be used only under those specific conditions.

#### **4 Units of measurement**

4.1 values stated without parentheses are the requirement. Values in parentheses are explanatory or approximate information.

#### **5 References**

5.1 any undated reference to a code or standard appearing in the requirements of this standard shall be interpreted as referring to the latest edition of code or standard.

### **CONSTRUCTION**

#### **6 General**

6.1 A flatiron shall employ materials found by investigation to be acceptable for the application.

#### **7 Frame and enclosure**

7.1 A flatiron shall be provided with an enclosure that will house all electrical parts other than the power-supply cord or the terminal pins.

7.2 A flatiron shall be form and assembled so that it will have the strength and rigidity necessary to resist the abuses to which it may be subjected, without increasing the risk of fire, electric shock, or injury to persons due to total or partial collapse with resulting reduction of spacings, loosening or displacement of parts, or other serious defects.

7.3 An enclosure, an opening, a frame, a guard, a knob, a handle, or the like shall not be sufficiently sharp to cause a risk of injury in maintenance or use of a flatiron or user maintenance of a modular flatiron.

7.4 among the factors to be taken into consideration when an enclosure is investigated for acceptability are its:

- a) Mechanical strength,
- b) Resistance to impact,
- c) Moisture-absorptive properties,
- d) Combustibility,
- e) Resistance to corrosion, and
- f) Resistance to distortion at temperatures to which the enclosure may be subjected under conditions of normal or abnormal use.

For a nonmetallic enclosure, all of these factors are to be considered with respect to thermal aging.

7.5 In addition to being considered with reference to factors as mentioned in 7.4, an enclosure of sheet metal should be investigated with respect to size and shape, thickness of metal, and acceptability for the application, considering the intended use of a flatiron.

7.6 cast –and sheet-metal portions of an enclosure shall not be thinner than specified in table 7.1.

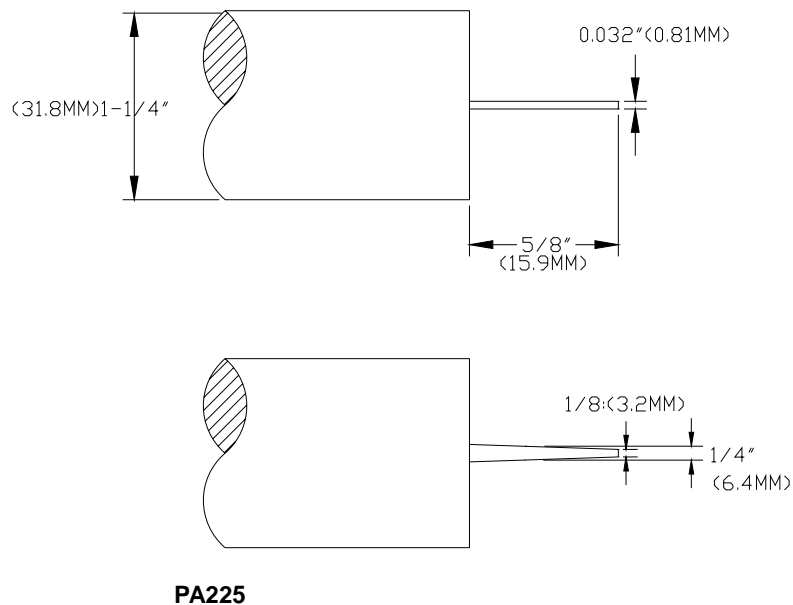
**Exception: an enclosure may be thinner if it is found to be acceptable when investigated by considerations such as those mentioned in 7.4 and 7.5.**

**Table 7.1**  
**Thickness of enclosure metal**

| Metal                   | Minimum thickness, in (mm)   |        |   |        |
|-------------------------|--|--------|---|--------|
|                         | At surface other than those to which a wiring system is to be connected in the field |        | At surface to which a wiring system is to be connected in the field |        |
| Die-cast metal          | 3/64   | (1.2)  | ---   | ---    |
| Cast malleable iron     | 1/16   | (1.6)  | ---   | ---    |
| Other cast metal        | 3/32   | (2.4)  | ---   | ---    |
| Uncoated sheet steel    | 0.026  | (0.66) | 0.032   | (0.81) |
| Zinc-coated sheet steel | 0.029  | (0.74) | 0.034   | (0.86) |
| Nonferrous sheet metal  | 0.036  | (0.91) | 0.045   | (1.14) |

7.7 An opening in the enclosure of a flatiron located within 1 in (25.4mm) of the soleplate surface is acceptable if the probe illustrated in Figure 7.1, when inserted point first, cannot be made to touch any uninsulated live part.

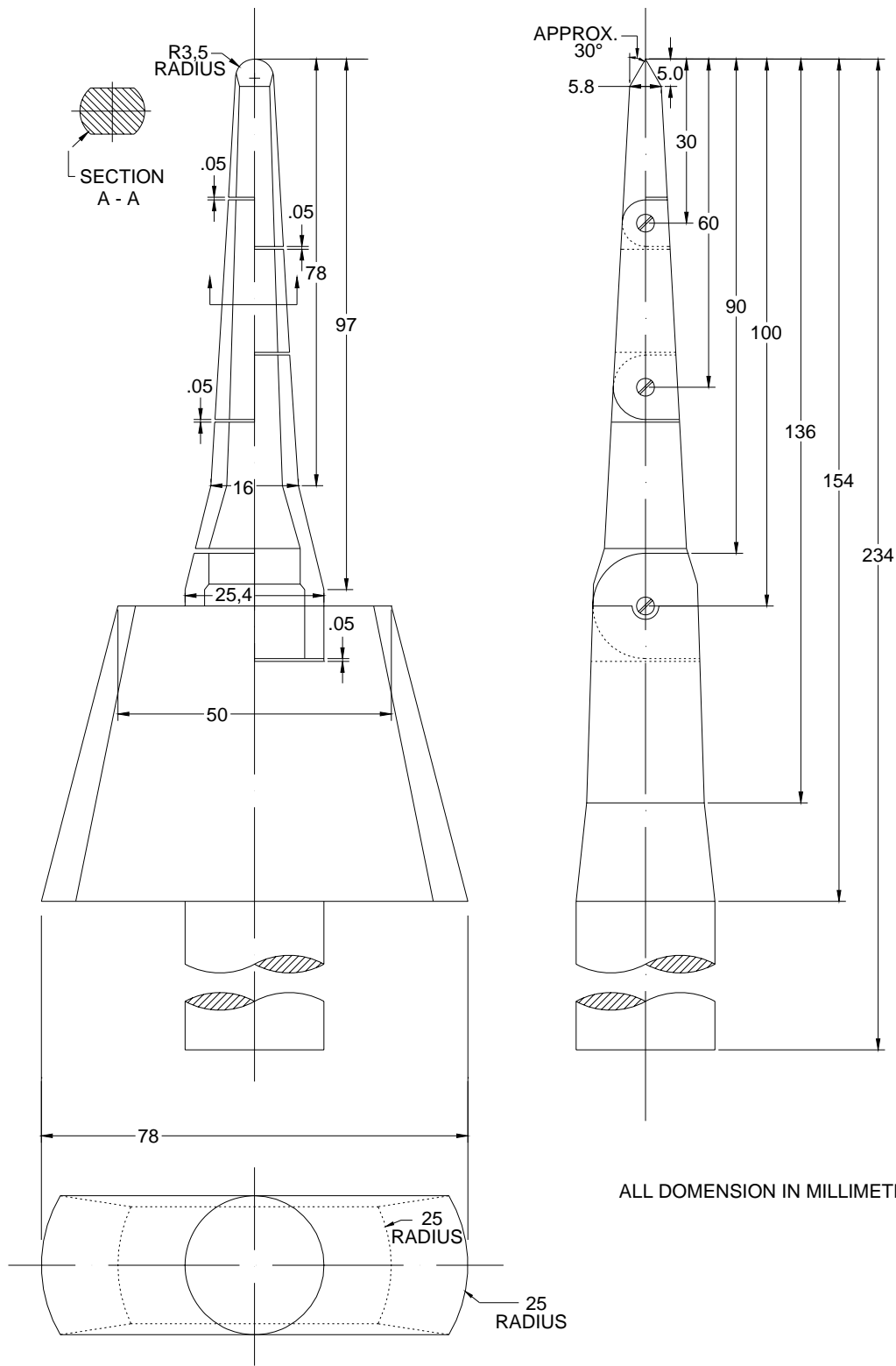
**Figure 7.1**  
**Probe**



7.8 An opening in an enclosure other than as mentioned in 7.7 shall not permit contact with live part by the probe illustrated in figure 7.2, when applied as described in 7.9.

7.9 With reference to 7.8 the probe illustrated in figure 7.2 is to be applied in any possible configuration and to any depth that the size of an opening will permit. The probe is to be rotated or angled to any possible position before, during, and after insertion through the opening; and, if necessary, the configuration is to be changed after the probe has been inserted through the opening.





## 8 Mechanical assemblies

8.1 An uninsulated live part and a component such as a switch, a lampholder, an attachment-plug receptacle, a plug-type connector, or the like shall be securely mounted and prevented from turning or shifting in position if such motion may result in:

- a) A reduction of spacing below the minimum acceptable values specified in section 18, Spacing, or
- b) Stress on the conductors of the component, or
- c) Both (a) and (b).

8.2 A properly applied lock washer is acceptable as a means to reduce the likelihood of turning of a stem-mounted switch.

8.3 Flatirons between surfaces are not acceptable as a means to reduce the likelihood of shifting or turning of live parts, but a properly applied lock washer is acceptable.

*Exception: a lock washer is not required for securely riveted, integral parts of a stack-type thermostat.*

8.4 Rigid connection of a thermostat with a solid wire or a bus bar is acceptable to reduce the likelihood of shifting or turning if the thermostat is otherwise securely mounted.

8.5 In a flatiron of modular design, a module that is likely to need inspection, replacement, or cleaning, by the user and that is intended to be manually operated or adjusted or periodically serviced shall be readily accessible without the use of a tool available only to service personnel. See 47.3.

## 9 Stands

9.1 A flatiron shall be provided with a stand on which it may be placed when not in use.

9.2 The stand may be a separate device or it may be a stand attached to the appliance, such as a heel rest.

## 10 Handles

10.1 A handle that may be folded for storage or for traveling convenience shall be provided with a means to lock the handle in the normal operating position.

10.2 A handle that automatically locks when it is raised to the operating position shall make an audible sound when moved into the locked position.

10.3 The means to actuate a mechanism that requires a positive motion by the operator to lock the handle in the operating position shall be evident.

10.4 A positive motion by the operator shall be required to release the locking mechanism to fold the handle. The release mechanism shall be designed and located so as to reduce the possibility of unintentional tripping. This will usually require that the release mechanism not be associated with the gripping area of the handle.

## 11 Protections against corrosion

11.1 Iron and steel parts shall be protected against corrosion by painting, galvanizing, plating, or other equivalent means, if corrosion of such unprotected parts would be likely to result in a risk of fire, electric shock, or injury to persons.

*Exception no. 1: a sheet-steel surface within a dry flatiron where oxidation is not likely to be accelerated due to exposure to air and moisture or other oxidizing influences – thickness of metal and temperature also being factors – may not be required to be protected against corrosion.*

*Exception no. 2: cast-iron parts need not be protected against corrosion.*

11.2 Deterioration of the plating or other finish due to aging shall not result in any condition that will adversely affect the operation of the flatiron.

## 12 Supply-connected flatirons

### 12.1 permanently connected flatirons

#### 12.1.1 General

12.1.1.1 A commercial flatiron may be cord-connected in accordance with 12.2.1.1- 12.2.3.3 or shall be provided with wiring terminal or leads for the connection of conductors of a wiring system that would be acceptable for the flatiron.

12.1.1.2 A terminal box or compartment in which power –supply connections to a permanently connected flatiron is to be made shall be located so that these connections may be readily inspected after the flatiron is installed as intended.

12.1.1.3 A terminal compartment intended for the connection of a supply raceway shall be attached to the flatiron so that it cannot turn.

12.1.1.4 A permanently connected flatiron employing a cord reel shall comply with the requirements in the Standard for cord reel, UL 355.

#### 12.1.2 Wiring terminals and leads

12.1.2.1 Wiring terminal or leads provided on an automatic flatiron intended for permanent connection to the power supply shall be acceptable for the connection of conductors having an ampacity that is not less than the current rating of the appliance. A nonautomatic flatiron shall be provided with wiring terminals or leads having an ampacity of not less than 125 percent of the current rating of the flatiron.

12.1.2.2 A wiring terminal shall be provided with a pressure wire conductor securely fastened in place, for example, firmly bolted or held by a screw.

*Exception: a wire-binding screw may be employed at a wiring terminal intended to accommodate a 10 AWG(5.3 mm<sup>2</sup>) or smaller conductor if upturned lugs or the equivalent are provided to hold the wire in position.*

12.1.2.3 A wiring terminal shall be prevented from turning or shifting in position by means other than friction between surfaces. This may be accomplished by:

- a) Two screws or rivets,
- b) Square shoulders or mortises,
- c) A dowel pin, lug or offset,
- d) A connecting strap or clip fitted into an adjacent part, or
- e) Some other equivalent method.

12.1.2.4 A wire –binding screw at a wiring terminal shall not be smaller than a No.10 screw.

*Exception No. 1: A No.8 screw may be used at a terminal intended only for the connection of a 14AWG (2.1mm<sup>2</sup>) conductor.*

*Exception No.2: A No.6 screw may be used for the connection of a 16AWG (1.3mm<sup>2</sup>) or 18AWG (0.82 mm<sup>2</sup>) control-circuit conductor.*

12.1.2.5 A wire- binding screw shall thread into metal.

12.1.2.6 For a terminal plate tapped for a wire – binding screw:

- a) The metal shall not be less than 0.050 in (1.27mm) thick.
- b) Each tapped hole shall have two or more full threads in the metal, which may be extruded if necessary to, provided the threads.

*Exception: A plate not less than 0.030 in (0.76mm) thick is acceptable provided the tapped threads have equivalent mechanical strength.*

12.1.2.7 Upturned lugs or a cupped washer shall be capable of retaining a conductor of the size mentioned in 12.1.2.1 but not smaller than 14AWG(2.1 mm<sup>3</sup>), under the head of the screw or the washer .

12.1.2.8 A flatiron intended for connection to a grounded power supply and employing a lampholder, a single-pole switch, or a single – pole automatic control shall have one terminal or lead identified as described in 12.12.9 or 12.1.2.10, for connection of the grounded conductor of the supply circuit. The terminal or lead intended to be grounded shall be the one that is connected to screw shells of lampholders, and to which are connected no single-pole switch or single-pole automatic controls.

12.1.2.9 A terminal intended for the connection of a grounded circuit conductor shall be made of or plated with a metal substantially white in color, and shall be readily distinguishable from the other terminals; or proper identification of that terminal shall be clearly shown in some other manner, such as on an attached wiring diagram.

12.1.2.10 A lead intended for the connection of a grounded circuit conductor shall be finished to show a white or gray color and shall be readily distinguishable from the other leads.

12.1.2.10 revised February 18,2004

12.1.2.11 The free length of a lead inside an outlet box or wiring compartment shall be 6 in (152mm) or more if the lead is intended for field connection to an external circuit.

*Exception: A lead may be less than 6 in (152mm) long if it is evident that the use of a longer lead might result in a risk of fire or electric shock.*

### 12.1.3 Equipment – grounding conductor

12.1.3.1 A wiring terminal or lead shall be provided for field connection of an equipment–grounding conductor.

12.1.3.2 The surface of an insulated lead intended solely for the connection of an equipment–grounding conductor shall be green with or without one or more yellow stripes, and no other lead shall be so identified.

12.1.3.3 A wire –binding screw intended for the connection of an equipment–grounding conductor shall have a green-colored head that is hexagonal, slotted, or both. A pressure wire connector intended for connection of such a conductor shall be plainly identified, such as by being marked “G,” “GND”, “GR” “Ground” “grounding”, or the like, or by a marking on an attached wire diagram.

12.1.3.4 A wire –binding screw or pressure wire connector intended for the connection of an equipment–grounding conductor shall be located inside the terminal compartment so that it is unlikely that it will be removed during servicing of the flatiron.

12.1.3.5 A terminal solely for connection of an equipment –grounding conductor shall be capable of securing a conductor of the size required for appliance.

## 12.2 Cord –connected flatirons

### 12.2.1 General

12.2.1.1 A flatiron intended to be connected to the power- supply circuit by means of a flexible cord shall be provided with an attached flexible cord and an attachment plug for connection to the supply circuit, or shall have male pin terminal that accommodate a cord set intended to be used with the flatiron.

12.2.1.2 A cord –connected flatiron employing a cord reel shall comply with the requirement in the Standard for cord reels, UL 355.

12.2.1.3 A supply cord shall be type HPD, HPN, HS, HSJ, HSJO, HSO, or an equivalent heater cord.

12.2.1.4 The length of an attached cord or a separate cord set shall not be greater than 12 ft (3.66m) and not less than:

- a) 6 ft (1.88m) for a commercial flatiron, and
- b) 8 ft (2.44m) for a household flatiron.

12.2.1.5 The length of the power supply cord is to be measured from the point where the cord enters the appliance to the face of the attachment plug. The length of a cord set is to be measured from the face of the flatiron or appliance plug to the face of the attachment plug.

12.2.1.6 The current and voltage rating of the cord and the fitting of an attached flexible cord or a separate cord set provided with a flatiron shall not be less than that of the flatiron. A 20- A plug is acceptable for a commercial flatiron rated not more than 4000W at 240V.

12.2.1.7 The attachment plug of the power supply cord of an appliance provided with a 15- or 20A rated general –use receptacle shall be of the 3- wire grounding type. The attachment plug of the power supply cord of an appliance shall be of the polarized or grounding type if provided with:

- a) A manually operated, line- connected, single pole switch for appliance on –off operation, or
- b) An Edison –base lampholder.

12.2.1.8 If a 3-wire grounding-type attachment plug or a 2-wire polarized attachment plug is provided, the attachment plug connections shall comply with figure 12.1.

12.2.1.9 The conductor of the power supply cord that is intended to be grounded shall have the following items connected to it:

- a) The screw shell of an Edison–base lampholder, and
- b) The terminal or lead of a receptacle intended to be grounded.

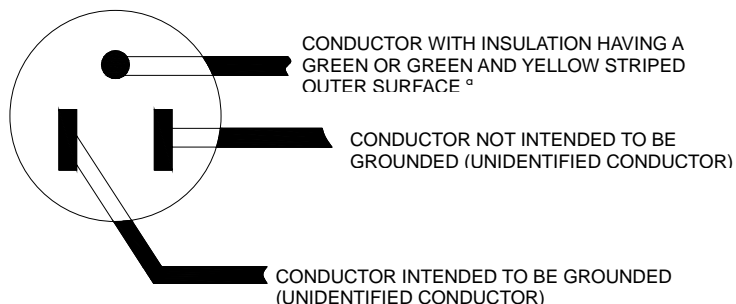
12.2.1.10 If a dual voltage flatiron is provided with an adapter for connection to an alternate supply source, the adapter shall comply with the applicable requirements in the standard for attachment plugs and receptacles, UL 498

No Text on This Page

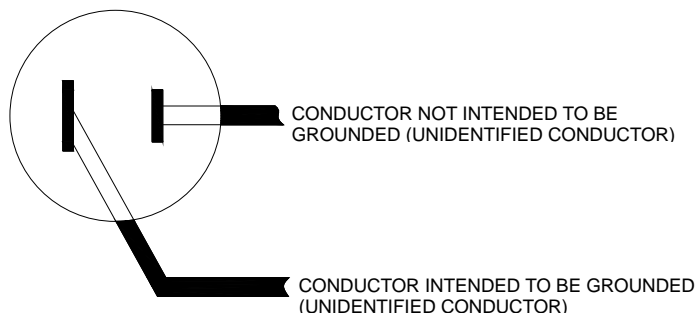


**Figure 12.1**  
**Connection to attachment plug**

CONNECTIONS OF CORD CONDUCTORS TO GROUNDING –TYPE  
 ATTACHMENT PLUG (FACE OFF PLUG REPRESENTED)



CONNECTIONS OF CORD CONDUCTORS TO POLARIZED  
 ATTACHMENT PLUG (FACE OF PLUG REPRESENTED)



° In the above illustration, the blade to which the green conductor is connected may have a U-shaped or circular cross section,

12.2.2 Cord guard

12.2.2.1 To reduce sharp bending of the cord at the inlet and to protect the cord from sharp edges or burrs, a flatiron with an attached flexible cord shall be provided with a cord guard.

12.2.2.2 The cord guard shall be held securely in place in the assembled flatiron. The diameter of a spring guard shall accommodate the cord without restriction or unnecessary looseness. A smooth metal grommet or a bushing is acceptable at the free end of a spring guard if it is held securely in place. The guard shall be flexible to conform to the motion of the cord in service without producing a sharp bend at or near the point of attachment to the flatiron.

### 12.2.3 Strain relief

12.2.3.1 Strain relief shall be provided to reduce the likelihood of mechanical stress on an attached flexible supply cord from being transmitted to terminals, splices, or interior wiring. See Section 40-Strain Relief test.

12.2.3.2 Wood, pressed board, or other fibrous material used to secure the strain-relief assembly, shall be secured to the flatiron by a pin, setscrew, or other positive means.

12.2.3.3 If a knot serves as strain relief for an attached flexible cord, all surfaces that the knot may contact shall be free from projections, sharp, edges, burrs, fins, or the like that may abrade the insulation on the conductors.

### 12.2.4 Pushback relief

12.2.4.1 Means shall be provided to prevent an attached flexible cord from being pushed into the enclosure of a flatiron through the cord- entry hole when such displacement results in:

- a) Subjecting the cord to mechanical damage;
- b) Exposing the cord to a temperature higher than that for which it is rated;
- c) Reducing spacing, such as to a metal strain- relief clamp, below the minimum required values; or
- d) Damaging internal connections or components.

To determine compliance, the cord shall be tested in accordance with push-back relief test, section 41.

### 12.2.5 Pin terminal

12.2.5.1 Pin terminals that are provided for connection of an appliance to the power supply shall be guarded or recessed so that any pin, where live, cannot be contacted unintentionally by persons while the cord connector or plug is fully seated or is being removed from or placed on the pins. The guard or recess is to be investigated as specified in 12.2.5.2 and 12.2.5.3.

12.2.5.2 With no plug or cord connector on the pins, a straightedge placed in any position across and in contact with the guard or recess shall not touch any pin that is live when the appliance is connected to a branch circuit.

12.2.5.3 With the contact openings in the plug or cord connector aligned with the pins and with the face of the plug or connector located in the plane perpendicular to the end of the farthest projecting pin that is live when the appliance is connected to a branch circuit, it shall not be possible by means of the probe illustrated in figure 7.2 to touch any pin that is live when the appliance is connected to a branch circuit.

12.2.5.4 The plug specified in 12.2.5.1 is to be either:

- a) A standard flatiron or appliance plug if the pins on the flatiron are of standard flatiron- or appliance – plug configuration, or
- b) The plug supplied with the flatiron, if the pins on the flatiron are not of a standard flatiron – or appliance – plug configuration.

12.2.5.5 If a flatiron employs three or more pin terminal designed for use with a plug that covers all the pins, the terminals shall be spaced so that they will not accommodate a 2- pin flatiron or appliance plug or cord connector .the plug that the pins will accommodate shall be acceptable for the application.

12.2.5.6 A pin terminal shall be prevented from turning or shifting in position by means other than flatiron between surfaces. This may be accomplished by:

- a) Two screws or rivets:
- b) Square shoulder or mortises;
- c) A dowel pin, lug, or offset;
- d) A connecting strap or clip fitted into an adjacent part; or
- e) Some other equivalent method.

12.2.5.7 For a household flatiron, the dimensions of pins and their center- to –center spacing, including the corresponding spacing of the female contacts of general-use plugs that the pins will accommodate, shall be as specified in table 12.1.

*Exception: pin terminals are not required to comply with the dimensions specified in table 12.1 if the plug provided on a cord set supplied with the iron is not interchangeable with flatiron plugs and appliance plugs that are commonly supplied with heating appliances.*

**Table 12.1  
Configuration of plugs for cord sets**

| Type and rating of plug that accommodates pins              | Amperes |      | Configuration and dimensions of pins |                      |                                 |                      |                        |
|---|---------|------|--------------------------------------|----------------------|---------------------------------|----------------------|------------------------|
|   | 125V    | 250V | Number                               | Arrangement          | Spacing Between Center, in (mm) | Diameter, in (Mm)    | Length, in (mm)        |
| Appliance plug  | 10      | 5    | 2                                    | In line              | 1/2 (12.7)                      | 5/32±0.005 (4.0±0.1) | 9/16 –5/8 (14.3- 15.9) |
| Flatiron plug   | 10      | 5    | 2                                    | In line              | 11/16(17.5)                     | 3/16±0.005 (4.8±0.1) | 3/4-7/8 (19.0-22.2)    |
| Jumbo appliance plug  | 10      | 10   | 2                                    | In line              | 1-1/16(27.0)                    | 3/16±0.005 (4.8±0.1) | 3/4-7/8 (19.0-22.2)    |
| Reversible Plug- for Two- heat Control <sup>a</sup>         | 15      | 10   | 3                                    | In line              | 7/8( 22.2)                      | 3/16±0.005 (4.8±0.1) | 3/4-7/8 (19.0-22.2)    |
| Reversible Plug-for Two- or three-heat Control <sup>a</sup> | 15      | 10   | 3                                    | Equilateral Triangle | 7/8( 22.2)                      | 3/16±0.005 (4.8±0.1) | 3/4-7/8 (19.0-22.2)    |

<sup>a</sup> Usually this plug is made without a contact in one of the holes.

12.2.5.8 Pin terminals of a commercial flatiron shall not accommodate a plug that will accommodate the pin terminals described in 12.2.5.7.

### 12.3 Cordless flatirons

12.3.1 The length of an attached supply cord or separate cord set connected to the power stand of a cordless flatiron shall not be less than 6 ft (1.88m).

## 13 Current –carrying parts

13.1 A current –carrying part shall be made of metal that is acceptable for the application.

13.2 A current –carrying part made of a corrosion–resistant alloy, such as stainless steel of an austenitic, 18 percent chromium, 8 percent nickel type, is acceptable regardless of temperature.

13.3 Ferrous metal current –carrying parts made of ordinary iron and steel other than mentioned in 13.2 are not acceptable.

*Exception: the following parts may be made of iron or steel provided they are acceptable protected against corrosion:*

- a) *Pin terminals;*
- b) *Parts that operate at a temperature higher than 100 °C ( 212 °F);and*
- c) *Parts of a component referred to in 3.1.*

13.4 A live part shall be located or protected so that it will not be subject to wetting caused by deterioration or breakage of a polymeric water reservoir of a flatiron unless the reservoir is of material acceptable for temperatures encountered, and does not develop cracks as a result of aging.

## 14 Internal wiring

### 14.1 General

14.1.1 Internal wiring of a flatiron shall consist of wires of a type or types that are acceptable for the application, when considered with respect to the temperature, voltage, and, other conditions of service to which they are likely to be subjected.

14.1.2 The supply cord is not considered to be part of the internal wiring.

14.1.3 A length of flexible heater cord shall be provided between the iron and the terminal compartment of a permanently connected flatiron.

14.1.4 Wires within an enclosure, compartment, raceway, or the like shall be located, secured, or protected so that no damage to conductor insulation can result from contact with any rough, sharp, or moving part,

## 14.2 Splices

14.2.1 Each splice and connection shall be mechanically secure and shall provide reliable electrical contact. A soldered connection shall be made mechanically secure before being soldered if breaking or loosening of the connection may result in a risk of fire or electric shock. The solder shall be acceptable for the temperatures to which the soldered connection may be subjected under conditions of normal operation.

14.2.2 A welded or brazed connection is considered to be mechanically secure.

14.2.3 A splice shall be provided with insulation equivalent to that of the wires involved if permanence of spacing between the splice and metal parts of the flatiron may not be maintained.

14.2.4 If stranded internal wiring is connected to a wire-binding screw, loose strands of wire shall be positively prevented from contacting any uninsulated live part that is not always of the same polarity as the wire, and from contacting any dead metal part. This may be accomplished by the use of pressure terminal connectors, crimped eyelets, soldering all strands of the wire together—the solder employed shall be acceptable for the temperature to which it may be subjected—or other equivalent means.

## 15 Electrical insulation

15.1 An insulation washer, bushing, and the like that is an integral part of a flatiron, and a base or support for the mounting live part shall be of a moisture –resistant material that will not be adversely affected by the temperatures that it will encounter in actual use. A molded part shall be constructed so that it will have the mechanical strength and rigidity necessary to withstand the stresses of normal operation.

15.2 Insulating material is to be investigated with respect to the application. Materials such as natural mica, some molded compounds, and certain refractory materials, such as ceramics, fiberglass, nylons and phenolics, are usually acceptable for use as the sole support of live parts; and some other materials that are not acceptable for general use, such as magnesium oxide, may be acceptable if used in conjunction with other acceptable insulating materials or if located and protected so that the risk of mechanical damage is reduced and the absorption of moisture is reduced. If it is necessary to investigate a material to determine whether it is acceptable, consideration is to be given to its mechanical strength, dielectric properties, electric resistance, and heat-resistance qualities, the degree to which it is enclosed or protected, and any other features having a bearing on the risk of fire, electric shock, and injury to persons involved, in conjunction with conditions of actual service. All of these factors to be considered with respect to thermal aging.

15.3 A screw or other fastening used for mounting or supporting a small, fragile, insulating part shall not be tight enough to crack or break the part as a result of expansion contraction.

## 16 Thermal insulation

16.1 Thermal insulation shall be of such a nature and located and mounted or supported so that it will not be adversely affected by normal operation of the flatiron.

16.2 Thermal insulation shall not make direct contact with an uninsulated live part.

*Exception: glass wool or other material that investigation has shown to be acceptable for the purpose may contact an uninsulated live part.*

## 17 Switches and controls

### 17.1 General

17.1.1 A switch or other control device shall have a current and voltage rating not less than that of the load that it controls.

17.1.2 On a dual voltage flatiron, the construction of the circuit voltage selector shall be such that the circuit voltage setting cannot be changed inadvertently.

17.1.3 On a dual voltage flatiron, the action of changing the voltage selector setting shall also change the supply circuit voltage indication.

17.1.4 A manually operated, line- connected, single pole switch for appliance on-off operation shall not be connected to the conductor of the power supply cord intended to be grounded.

17.1.5 A flatiron shall be constructed so that:

- a) The means to adjust the maximum setpoint temperature of the temperature control is not evident to the user, and
- b) The use of a tool is required to adjust the maximum setpoint temperature of the temperature control.

### 17.2 Backup protective devices

17.2.1 A backup protective device that is depended upon for compliance with the requirement in 37.2.1 shall:

- a) Be a noncycling device, and
- b) Operated as required when tested in accordance with 37.2.4

*Exception: A commercial flatiron may be provided with an automatic –reset, temperature-limiting protector if the flatiron complies with the requirements in 17.2.2.*

17.2.2 A commercial flatiron provided with an automatic – reset, temperature- limiting control that is not bypassed for the tests described in abnormal operation test, section 37, shall also be provided with an indicator to alert the user that the flatiron is not operating normally. See indicator lights, section 22, tests on automatic reset controls, section 35, and tests on indicator light, section 36.

17.2.3 A backup protective device shall not be user- replaceable, and it shall not be visible or accessible to the user during normal operation of the flatiron r after the removal of parts that can be removed without the use of a tool.

**18 Spacing**

18.1 The spacing between uninsulated live parts shall be as specified in table 18.1.

*Exception no. 1: The inherent spacing of a component of a flatiron is investigated under the requirements for the component.*

*Exception no. 2: At closed-in point only, such as the screw –and –washer construction of an insulated terminal mounted in metal, a spacing of 3/64 in (1.2mm) is acceptable in an appliance rated 250v or less.*

*Exception no. 3: Within a thermostat, except at contacts, the spacing between uninsulated live parts on opposite sides of the contacts may be not less than 1/32 in (0.8mm) through air and 3/64 in (1.2mm) over the surface of insulating material; the construction is to be such that the spacings will be permanently maintained.*

*Exception no. 4: A spacing, through air and over surface, of not less than 1/16 in (1.6mm) between live parts of opposite polarity and between live parts and dead metal parts shall be maintained at or near the end of the sheath of a heating element rated 300 V or less. If exact centering of the cold pin is required to maintain the 1/16 in spacing, a spacing of 3/64 in (1.2mm) in one location is acceptable.*

**Table 18.1  
Spacing between uninsulated live parts**

| Part involved  | Potential involved, v | Minimum spacing, in (mm) |        |                  |        |
|--|-----------------------|--------------------------|--------|------------------|--------|
|  |                       | Through air              |        | Over surface     |        |
| 1. Between field-wiring terminals and live parts of opposite polarity; and between a live part and a dead metal part, other than the enclosure, that may be grounded. <sup>a, b</sup>                            | 0-250                 | 1/4                      | (6.4)  | 3/8              | (9.5)  |
|  | 251-600               | 3/8                      | (9.5)  | 1/2              | (12.7) |
| 2. Between live parts of field –wiring terminals and the enclosure <sup>a, b</sup>   | 0-600                 | 1/2                      | (12.7) | 1/2              | (12.7) |
| 3. Between uninsulated live parts of opposite polarity; and between a rigidly mounted uninsulated live parts and a dead metal part that is either exposed to contact by persons or may be grounded. <sup>c</sup> | 0-250                 | 1/16                     | (1.6)  | 1/16             | (1.6)  |
|  | 250-600               | 1/4 <sup>d</sup>         | (6.4)  | 1/4 <sup>d</sup> | (6.4)  |

<sup>a.</sup> The spacing do not apply to connecting straps or buses extending away from wiring terminals. Such spacing are to be investigated under item 3.

<sup>b.</sup> Applied to the sum of the spacing involved where an isolated dead part is interposed.

Table 18.1 Continued on Next Page

**Table 18.1 Continued**

| Part involved  | Potential involved, v | Minimum spacing, in (mm) |              |
|--|-----------------------|--------------------------|--------------|
|  |                       | Through air              | Over surface |
| <sup>c.</sup> If an uninsulated live parts not rigidly supported, or if a moveable dead metal part is in proximity to an uninsulated live part, the construction shall be such that at least the minimum acceptable spacing of 1/16 in (1.6mm) is maintained under all operating conditions and under all normal conditions of handling. |                       |                          |              |
| <sup>d.</sup> A spacing of 1/16 in (1.6mm) is acceptable at the heating element only, in a flatiron rated for 300v or less.  |                       |                          |              |

18.2 A printed wiring board with spacing between opposite polarity circuits (other than a low – voltage circuit) less than those specified in 18.1 is acceptable provided that the spacing:

- a) Are located on a portion of the printed wiring board provided with a conformal coating that complies with the requirements in the standard for polymeric materials – use in Electrical Equipment evaluations, UL 746c, and the dielectric voltage-withstand test in 30.1;
- b) Are located on the load side of a resistor or capacitor such that a short circuit from the load side of the component to the other side of the line does not result in a power dissipation exceeding the resistor wattage rating or the voltage across the capacitor exceeding the capacitor voltage rating; or
- c) Comply with the applicable requirements in the Standard for Insulation Coordination including Clearances and Creepage Distances for Electrical Equipment, UL 840.

18.3 With reference to 18.2(c), it is anticipated that a flatiron is rated with an overvoltage category of II, and a pollution degree of 2, as defined in the standard for insulation coordination including clearances and creepage distances for electrical equipment, UL 840.

18.4 With reference to 18.2(c) and 18.3, a printed wiring board is considered to have a minimum comparative tracking index (CTI) of 100 without further investigation.

## 19 Barriers

19.1 An insulating liner or barrier of fiber or similar material employed where spacing would otherwise be insufficient shall not be less than 1/32 in (0.8mm) thick and shall be so located or of such material that it cannot be adversely affected by arcing.

*Exception no. 1: Fiber not less than 1/64 in (0.4mm) thick may be used in conjunction with an air spacing of not less than 50percent of the spacing required for air alone.*

*Exception no. 2: Insulating material having a thickness less than 1/32 in (0.8mm) that has been investigated and found to be acceptable for the application.*

19.2 Unless protected from mechanical abuse during assembly and normal functioning of a flatiron, a barrier of mica shall be at least 0.010 in (0.25mm) thick.



## 20 Grounding

20.1 In a flatiron intended for permanent connection to the power supply by a metal- enclosed wiring system such as rigid metal conduit or armored cable, all exposed dead metal parts that are likely to become energized and all dead metal parts inside the enclosure that are exposed to contact during any maintenance or repair operation and that are likely to become energized shall be conductively connected to the point at which the cable armor, conduit, and the like is attached to the flatiron.

20.2 In a flatiron intended for permanent connection to the power supply by means other than a metal –enclosed wiring system such as nonmetallic-sheathed cable, all exposed dead metal parts that are likely to become energized and all dead metal parts inside the enclosure that are exposed to contact during any maintenance or repair operation and that are likely to become energized shall be conductively connected to the equipment –grounding terminal or lead of the flatiron.

20.3 The power-supply cord of a cord-connection flatiron shall include an equipment grounding conductor if the flatiron is intended for:

- a) Commercial use;
- b) Operation on a circuit involving a potential of more than 150v to ground; or
- c) Operation at a nominal potential of 240v and any other potential within the 220-250v ranges.

*Exception: This requirement does not apply to a flatiron with a marked rating of 120/240v or marked to indicate that it is to be connected only to a 120/240-v circuit with a grounded neutral.*

20.4 An equipment –grounding conductor of a flexible cord shall be:

- a) Finished to show a green color with or without one or more yellow stripes;
- b) Connected to the grounding member of an attachment plug of the fixed grounding type; and
- c) Connected, by a screw or other reliable means not likely to be removed during any maintenance and repair operation, to all exposed dead metal parts that are likely to become energized, and all dead metal parts inside the enclosure that are exposed to contact during any maintenance or repair operation and that are likely to become energized. Solder alone shall not be used for securing the grounding conductor.

20.5 A flatiron provided with a means for grounding, even though it is not required, shall comply with the requirements in 20.3 and 20.4.

## 21 Parts subject pressure

### 21.1 General

21.1.1 The strength of a flatiron, the operation of which involves the generation and confining of steam under pressure, shall preclude the risk of an explosion.

*Exception: This requirement does not apply to a steam flatiron in which tank filler tube is open to the atmosphere.*

21.1.2 A pressure vessel having an inside diameter of more than 6 in (152mm) and subject to a pressure of more than 15psig (102kPa) shall be certified by the national board of boiler and pressure –vessel Inspectors and marked in accordance with the appropriate boiler and pressure vessel code symbol of the American society of mechanical engineers (ASME/ANSI-1989) for a working pressure not less than the pressure determined as specified in 21.1.4.

21.1.3 A pressure vessel that is not covered under the inspection procedures of the ASME code because of its application shall be constructed so that it will comply with the requirements in 21.1.4.

21.1.4 A part or an assembly that is subject to air or vapor pressure during normal or abnormal operation, including the vapor pressure in a vessel containing only a superheated fluid, shall withstand without rupture a pressure equal to the highest of the following that is applicable:

- a) Five times the pressure corresponding to the maximum setting of a pressure-reducing valve provided as part of the assembly, but not more than 5 times the marked maximum supply pressure from an external source, and more than 5 times the pressure setting of a pressure-relief device provided as part of the assembly.
- b) Five times the mark maximum supply pressure from an external source, except as provided in item (a).
- c) Five times the pressure setting of a required pressure-relief device.
- d) Five times the working pressure marked on the part.

21.1.5 A section of a pressure system constructed of continuous tubing or of lengths of tubing connected by hand-soldered, brazed, or welded joints is considered to comply with the requirements in 21.1.4 if the wall thickness of the tubing is not less than the value specified in table 21.1.

**Table 21.1**  
**Wall thickness for copper and steel tubing**

| Outside diameter, |        | Minimum wall thickness, |        | Maximum pressure to which tubing is subjected, PSIG (Mpa) |        |                   |        |                |        |
|-------------------|--------|-------------------------|--------|---|--------|-------------------|--------|----------------|--------|
| in                | (mm)   | in                      | (mm)   | seamless copper   |        | butt-welded steel |        | seamless steel |        |
| 3/8 or smaller    | (9.5)  | 0.016                   | (0.41) | 500   | (3.45) | 600               | (4.14) | 1000           | (6.90) |
| 1/2               | (12.7) | 0.016                   | (0.41) | 400   | (2.76) | 480               | (3.31) | 800            | (5.52) |
| 5/8               | (15.9) | 0.016                   | (0.41) | 320   | (2.21) | 384               | (2.65) | 640            | (4.42) |
| 5/8               | (15.9) | 0.021                   | (0.53) | 420   | (2.90) | 504               | (3.48) | 840            | (5.80) |
| 3/4               | (19.0) | 0.021                   | (0.53) | 360   | (2.48) | 432               | (2.98) | 720            | (4.97) |
| 3/4               | (19.0) | 0.025                   | (0.64) | 420   | (2.90) | 504               | (3.48) | 840            | (5.80) |
| 1                 | (25.4) | 0.021                   | (0.53) | 260   | (1.79) | 312               | (2.15) | 520            | (3.59) |
| 1                 | (25.4) | 0.025                   | (0.64) | 320   | (2.21) | 384               | (2.65) | 640            | (4.42) |

21.1.6 A pressure vessel bearing the ASME code inspection symbol H, M, S, or U is considered to comply with the requirement in 21.1.4 if the vessel is marked with a value of working pressure not less than that to which it is subject during normal or abnormal operation.

21.1.7 If a test is necessary to determine whether a part complies with the requirement in 21.1.4, two samples of the part are to be subjected to a hydrostatic-pressure test. Each sample is to be so filled with water as to exclude air and is to be connected to a hydraulic pump. The pressure is to be increased gradually to the specified test value and is to be held at that value for 1 min. the results are not acceptable if either sample bursts or leaks.

*Exception: Leakage at a gasket at not less than 40 percent of the required test pressure is acceptable.*

## 21.2 Pressure relief devices

21.2.1 A means for safely relieving pressure shall be provided for a part in which pressure might be generated in the event of fire.

21.2.2 A pressure –relief device –see 21.3 –fusible plug, soldered joint, nonmetallic tubing, or other equivalent pressure- relief means may be employed to comply with the requirement in 21.2.1.

21.2.3 A pressure-relief device is considered to be a pressure-actuated valve or rupture member designed to relieve excessive pressures automatically.

21.2.4 There shall not be a shut-off valve between the pressures –relief means and the parts that it is intended to protect.

21.2.5 A vessel having an inside diameter of more than 3 in (76.2mm) and subject to steam pressure generated or stored within the flatiron shall be protected by a pressure –relief device.

21.2.6 The start –to –discharge pressure setting of the pressure-relief shall not be higher than the working pressure marked on the vessel .the discharge rate of the device shall be capable of relieving the pressure.

21.2.7 A pressure –relief device shall:

- a) Be connected as close as possible to the pressure vessel or part of the system that it is intended to protect.
- b) Be installed so that it is readily accessible for inspection and repair and cannot be readily rendered inoperative; and
- c) Have its discharge opening located and directed so that the likelihood of scalding is reduced to an acceptable degree, and operation of the device will not deposit moisture on bare live parts or on insulation or components detrimentally affected by moisture.

21.2.8 A pressure-relief device having an adjustable setting is to be investigated on the basis of its maximum setting unless the adjusting means is reliably sealed at a lower setting.

21.2.9 If a pressure-relief device is required, the control that limits the pressure in the vessel shall perform at rated load for 100,000 cycles of operation and shall be such that the pressure does not exceed 90 percent of the relief-device setting under any condition of normal operation.

## **22 Indicator lights**

22.1 If a light is used as an indicator as mentioned in 17.2.2, it shall:

- a) Have a minimum rated life of 20000 continuous hours at the operating voltage and shall be connected in a circuit in which the increased voltage incident to switching or any other operational characteristic of the flatiron does not exceed 120 percent of the voltage recommended to provided the required life; and
- b) Be located so as to be visible during normal operation.

## **PERFORMANCE**

### **23 General**

23.1 A flatiron intended for use both as a dry flatiron and as a steam flatiron is to be tested in both the dry and steaming conditions unless it can be determined that one or the other condition results in maximum heating of the flatiron, in which case that condition may be used for all tests.

23.2 Circuitry employed to achieve an automatic shutoff feature shall be defeated in determining compliance with the performance requirements in this standard.

23.3 Unless otherwise specified, each of three samples of a flatiron shall be subjected to the applicable performance tests in the order in which they are presented.

23.4 Automatic flatirons selected for the performance tests shall be production flatirons having temperature controls calibrated by the manufacturer to the maximum production tolerance.

23.5 Unless otherwise specified, the flatiron is to be at normal operating temperature and is to be operated with any adjustable temperature control at the maximum setting.

23.6 Unless otherwise specified, a flatiron marked with a single voltage rating shall be tested at the marked voltage, except that if the rating fall within one of the following voltage ranges: 100-120, 220-240, 254-277, or 440-480, the flatiron shall be tested at the highest voltage of the range.

23.7 Unless otherwise specified, a flatiron marked with a voltage range, such as 110-120v, shall be tested at the highest value of the marked range.

## 24 Leakage current test

24.1 The leakage current of a cord-connected flatiron rated for a nominal 120 V or 120/240 V supply when tested in accordance with 24.2-24.8 shall not be more than 0.5mA.

*Exception: The leakage current of a flatiron incorporating a sheath type heating element when measured in accordance with 24.2-24.8 shall not exceed 2.5mA during the first 5 min after reaching the leakage current limit of 0.5mA; and, at the end of this time, the leakage current shall not be more than 0.5 mA. The leakage current is to be monitored during heat-up and cool-down.*

24.2 Leakage current refers to all currents, including capacitively coupled currents that may be conveyed between exposed conductive surfaces of a flatiron and ground or other exposed conductive surfaces of the flatiron.

24.3 All exposed conductive surfaces are to be tested for leakage currents .the leakage currents surface from these surfaces are to be measured to the grounded supply conductor individually as well as collectively where simultaneously accessible and from one surface to another where simultaneously accessible. Parts are considered to be exposed surfaces unless guarded by an enclosure that reduces the risk of electric shock as described in frame and enclosure, section 7. Surfaces are considered to be simultaneously accessible when they can be readily contacted by one or both hands of a person at the same time. These measurements do not apply to terminal operating at voltage that are considered not to present a risk of electric shock.

24.4 If a conductive surface other than metal is used for the enclosure or part of the enclosure, the leakage current is to be measured using a metal foil with an area of 10 by 20cm (3.9 by 7.9 in) in contact with the surface. If the surface is less than 10 by 20 cm, the metal foil is to be the same size as the surface. The metal foil is not be remain in place long enough to affect the temperature of the flatiron.

24.5 The measurement circuit for leakage current is to be as shown in figure 24.1. The measurement instrument is defined in items (a)-(c). The meter that is actually used for a measurement need only indicate the same numerical value for a particular measurement, as would the defined instrument. The meter used need not have all the attributes of the defined instrument.

a) The meter is to have an input impedance of 1500 ohms resistive shunted by a capacitance of 0.15uf.

b) The meter is to indicate 1.11 times the average of the full –wave rectified composite waveform of voltage across the resistor or current through the resistor.

c) Over a frequency range of 0-100kHz, the measurement circuitry is to have a frequency response-ratio of indicated to actual value of current –that is equal to the ratio of the impedance of a 1500-ohm resistor shunted by a 0.15uf capacitor to 1500 ohms. At an indicated of 0.5 to 0.75mA, the measurement is to have an error of not more than 5 percent at 60Hz.

24.6 Unless the meter is being used to measure leakage from one part of a flatiron to another, the meter is to be connected between accessible parts and the grounded supply conductor.

24.7 A sample flatiron is to be tested for leakage current starting with the as- received condition with all its switches and thermostats closed, but with its grounding conductor, if any, open at the attachment plug -the as-received condition being without prior energization except as may occur as part of the production-line testing. The supply voltage is to be 120 or 240v as applicable. The test sequence, with reference to the measuring circuit, figure 24.1 is to be as follows:

a) With switch S1 open and with the flatiron controls at the maximum heat setting. The flatiron is to be connected to the measuring circuit. Leakage current is to be measured using both positions of switch S2.

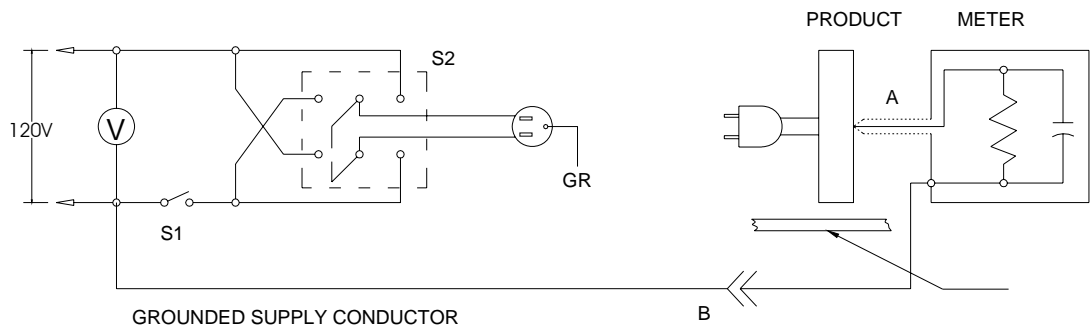
b) Switch S1 is then to be closed, energizing the flatiron, and within 5 s the leakage current is to be measured using both positions of switch S2.

c) Leakage current is to be monitored until thermal stabilization at the maximum heat condition. Both positions of switch S2 are to be used. The equivalent of thermal stabilization is considered to be obtained as in the normal temperature test. If any thermostat does not cycle at the maximum heat setting, it is to be adjusted until it does cycle before the final measurement at thermal stabilization are taken. Measurements are to be made with the thermostat, if any, open and closed. Upon evidence of stabilizing readings, monitoring periods may be increased.

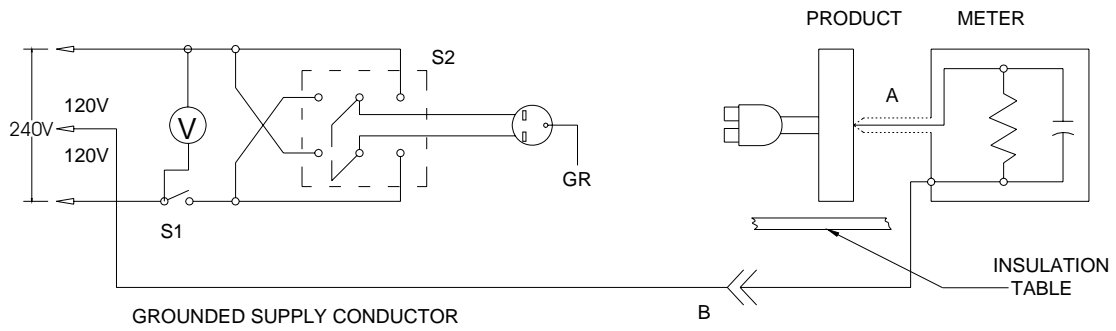
d) Leakage current of a flatiron having a single-pole switch or a control thermostat for adjusting temperatures is to be monitored until the leakage current stabilizes or decreases after the flatiron is turned off.

24.8 Usually, a sample will be tested for leakage current as described in 24.7 without interruption for other tests. With the concurrence of those concerned, the leakage current test may be interrupted for the purpose of conducting other nondestructive tests.

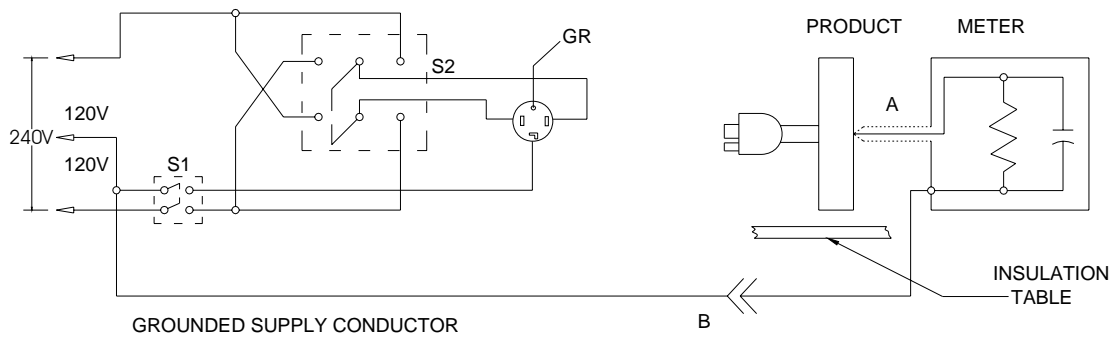
**Figure 24.1**  
**Leakage current measurement circuits**



Product intended for connection to a 120-volt power supply, as illustrated above



Product intended for connection to a 3-wire, grounded neutral power supply, as illustrated above



Product intended for connection to a 3-wire, grounded neutral power supply, as illustrated above

LC300J

NOTES—

- 1) A- Probe with shielded lead.
- 2) B- Separated and used as clip when measuring currents from one part of flatiron to another.

## 25 Power input test

25.1 When tested in accordance with 23.5-23.7, the power input to a flatiron shall not be more than 105 percent of its marked rating.

## 26 Soleplate temperature test

26.1 The soleplate of an automatic flatiron operated as described in 26.3 and 26.5-26.7 or a cordless flatiron operated as described in 26.3-26.7, shall not exceed:

a) A temperature of 350°C(662°F) during an initial interval of operation consisting of the first on period plus the first 5 min following the first thermostat cutoff;

*Exception: The maximum soleplate temperature may be more than 350°C (662°F) during the initial interval if the flatiron is tested as described in 26.7 and 26.9, and there is no evidence of ignition of the padding when the flatiron is lifted from the horizontal test stand during the cooling cycles within this interval .*

b) An average maximum temperature of 350°C(662°F) after the initial interval of operation described in item (a) ; or

c) An average temperature – the average of the mean of the maximum temperature and the mean of the minimum temperatures – of 315°C (599°F) after the initial interval of operation described in item (a).

26.2 When operated as described in 26.7 and 26.9, the soleplate temperature of a nonautomatic flatiron shall not exceed 315°C (599°F).

26.3 If the temperature control is adjustable, the flatiron is to be operated with the control set to give the highest temperature values.

26.4 A cordless flatiron is to be energized in its power stand.

26.5 For the test described in the exception to 26.1 (a), a cordless flatiron is to be electrically connected to the power stand and placed with the soleplate down on padded softwood horizontal test stand as described in 26.8.

26.6 The flatiron is to be supported on three pointed 1/4 in (6.4mm) diameter metal rods. The radius at the point is to be approximately 1/16 in (1.6mm). The rods are to have 4 in (100mm) or more of exposed length below the soleplate. The rods are to be standing on end or inserted in a supporting base and are to be positioned to provide the greatest stability. See figure 26.1.

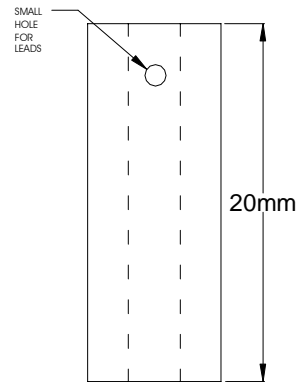
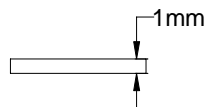
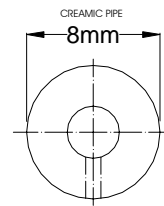
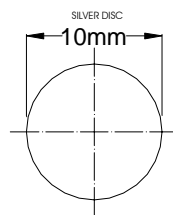
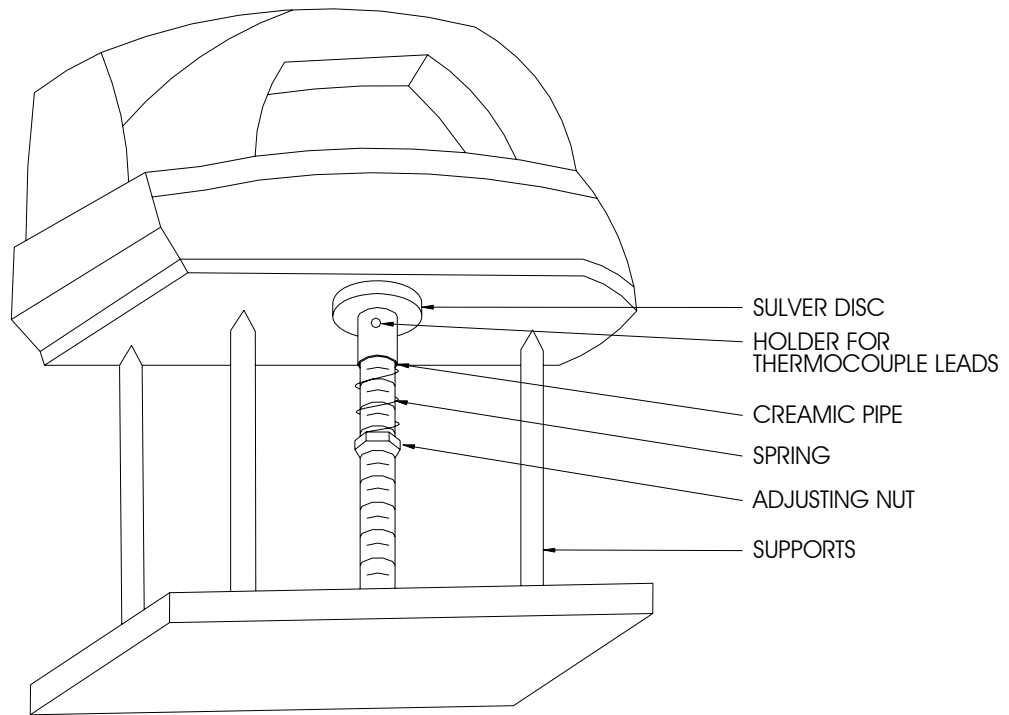
26.7 The soleplate temperature is to be measured at the hottest part on the soleplate as determined by a scorch print. A thermocouple of 30AWG iron and constantan wires is to be:

a) Peened into a small hole approximately 1/32 in (0.8mm) in diameter at the hottest part of the soleplate or

b) Applied to the soleplate as described in figure 26.1.



**Figure 26.1**  
**Test fixture**



**NOTE-**

1) <sup>a</sup>. A thermocouple is to be soldered at the center of the silver disc. The disc is to be fixed to the end of the ceramic pipe with heat-resistant adhesive and is to be free to align itself with the soleplate.

2) <sup>b</sup>. If the spring is strong enough to lift the iron off of the supports, means may be provided to hold the iron in place.

26.8 A scorch print is to be made by placing the iron, in the dry mode, on the test fixture, figure 26.1, and energizing it until the soleplate temperature at the midpoint exceeds 204°C (400°F). The iron is then to be disconnected from the supply and the iron is to be placed on a sheet or a white paper spread over an ironing board for sufficient time to develop a scorch pattern - normally a few seconds. After removal of the iron, darkening of the paper indicates the temperature distribution over the soleplate. The hottest point is the center of the darkest area. The coolest point is the center of the lightest area. Positive prototype paper, white tracing paper, or white blotting paper may be used as the white paper for this measurement.

26.9 For the test described in 26.2 and the Exception to 26.1 (a), the flatiron is to be placed with the soleplate down on a padded softwood horizontal test stand. The padding on the test stand is to consist of eight thickness of cloth. The cloth is to be bleached cheesecloth running 14 -15 square yards per pound mass (approximately 26- 28 square meters per kilogram mass) and having what is known in the trade as a count of 32 by 28, that is, for any square inch, 32 threads in one direction and 28 threads in the other direction (for any square centimeter, 13 threads in one direction and 11 in the other direction).

## **27 Mechanical abuse test**

### **27.1 Flatirons**

27.1.1 The drop tests described in 27.1.2 and 27.1.7 shall not:

- a) Cause an opening in the enclosure of a flatiron that will permit a probe having the dimensions shown in figure 7.2 to contact an uninsulated live part when inserted point –first into the opening;
- b) Damage a flatiron to the extent that it will not comply with the requirements in 26.1 and 26.2.
- c) Cause an opening in the enclosure of a flatiron located within 1 in (25.4mm) of the soleplate surface that will permit a probe having the dimensions shown inn figure 7.1 to contact an uninsulated live part when inserted point- first into the opening; or
- d) Result in leakage of water of steam from the steam chamber or water reservoir into the electrical compartment.

Revised 27.1.1 effective august 18,2005

27.1.2 An automatic flatiron is to be dropped five times from a height of 3ft (914mm) onto a wooden floor - once on each side, once on the point, once on the heel, and once flat; the first drop is to be made with the flatiron cold before it is connected to the supply circuit; the second drop is to be made after the flatiron has been heating for about 2 min and with the thermostatically controlled switch in the closed position; the third drop is to be made after the flatiron has become well heated and with the thermostat in the closed position; the fourth drop is to be made just after the thermostat has operated to open the switch; and the fifth drop is to be made after and the flatiron has cooled about half way to room temperature.

27.1.3 The drop tests described in 27.1.2 and 27.1.7 are to be conducted with water filled to the maximum level in the reservoir of a steam flatiron at the start of the test. The sling or drop platform mentioned in 27.1.7 may be used for the tests. Tape, silicon sealant, or equivalent means may be used during the test to prevent water from exiting the iron through the fill opening.

Revised 27.1.3 effective august 18, 2005



27.1.4 The wooden floor mentioned in 27.1.2 and 27.1.7 is to consist of a layer of nominally 1 -in (25.4mm) thick tongue- and -groove oak flooring mounted on two layer of 3/4 in (19.1mm) plywood. The assembly is to rest on a concrete floor or the equivalent during the test.



No Text on This Page

27.1.5 The drop test described in 27.1.2 may be conducted on three previously untested flatirons; however the three samples are first to be subjected to the soleplate temperature test, section 26, and following the test described in 27.1.2 are to be subjected to a repeated soleplate temperature test, and to the dielectric voltage –withstand test, section 30.

27.1.6 After being dropped on the handle as described in 27.1.7, the flatirons shall comply with the requirements in 27.1.1 and shall comply with the dielectric voltage –withstand test described in section 30, except that the test potential is to be 500v.

27.1.7 One of the flatirons subjected to the test described in 27.1.2 is to be dropped 3 times from a height of 3ft (914mm) so that the handle strikes a wooden floor or similar surface as described in 27.1.4. The flatiron is to be cold and is to be dropped so that the handle strikes in a different location each time – usually front, back, and center. The front and backdrops are to be made with the soleplate at a 45-degree angle to the horizontal, and the center drop test is to be conducted with the soleplate horizontal and facing up. So that the handle strikes the intended location, the iron is to be supported on a drop platform tester so that rotation will not occur during the drop, or rotation is to be prevented by supporting the iron in the desired orientation in a sling made by tying the four corners of a single layers of cloth measuring 18 in (455 mm) by 18 in (455 mm) to a single drop cord. The power –supply cord may be piled on top of the iron or cut off, provided that the sample is not needed for subsequent tests. The iron is to be dropped after it has been suspended and all motion has ceased.

*Exception: At the manufacturer's option, previously untested flatirons may be used for the handle drop test or the three flatirons that were used in the leakage current test, section 24, or the drop test specified in 27.1.2 may be used. One sample may be dropped three times, or each of three flatirons may be dropped once.*

## **27.2 Power stands for cordless flatirons**

27.2.1 The power stand of a cordless flatiron shall withstand the impact described in 27.2.4 and 27.2.6 without the occurrence of the following:

- a) Making uninsulated live parts accessible to contact it .the probe shown in figure 7.2 is to be used to determine if live parts are accessible;
- b) Producing a condition that might affect the mechanical performance of the flatiron; or
- c) Producing a condition that would increase the likelihood of an electric shock.

27.2.2 With reference to 27.2.1(b), cracking or denting of the enclosure is not to affect the function of any safety controls or constructional features such as thermostat, overload protective devices, waterseals, or strain relief. Cracking or denting of the enclosure is not to result in exposure of moving parts capable of causing injury to persons.

27.2.3 With reference to in 27.2.1 (c), the cordless flatiron is to comply with the dielectric voltage-withstand test after being subjected to the impact.

27.2.4 the power stand is to be subjected to the drop impact test described in (a) and (b).

a) Each of three samples is to be dropped through 3 ft (914mm) to strike a hardwood surface as described in 27.1.4.

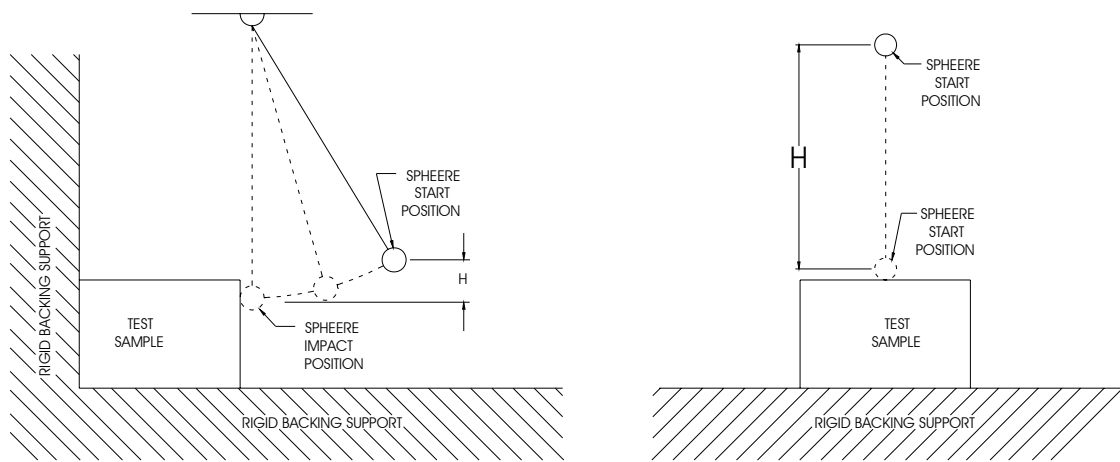
b) Each sample is to be dropped three times so that, in each drop, the sample strikes the surface in a position different from those in the other two drops.

27.2.5 The power stand, which is not likely to be dropped during intended use should be subjected to the ball impact test described in 27.2.6.

27.2.6 Each of three samples of the power stand is to be subjected to a single impact of 0.75 ft-lbs (1.02 J) on any surface that can be exposed to a blow during intended use. This impact is to be produced by dropping a steel sphere, 2 in (50.8mm) in diameter, and weighing 1.18lb (0.535kg) mass from the height necessary to produce the specified impact as shown in figure 27.1. The steel sphere shall strikes the surface in a location different from those in the other two impacts. For surfaces other than the top on an enclosure, the steel sphere is to be suspended by a cord and swung as a pendulum, dropping through the vertical distance necessary to cause it to strike the surface with the specified impact as shown in Figure 27.1.



**Figure 27.1**  
**Ball impact tests**



**NOTES-**

- 1) H indicates the vertical distance the sphere must travel to produce the desired impact.
- 2) For the ball- pendulum impact test the sphere is to contact the test sample when the string is in the vertical position as shown.
- 3) The backing surface is to consist of 3/4 in (19.1mm) plywood over a rigid surface of concrete. An equivalent nonresilient backing surface may be used.

## 28 Temperatures-control endurance test

28.1 an automatic flatiron shall comply with the requirements in 26.1 and 29.1.1:

- a) For a household flatiron, after 500 h of operation; and
- b) For a commercial flatiron, after 1667 h of operation.

28.2 During the endurance test, the flatiron is to be operated on its soleplate and is to be allowed to cool to room temperature at least 10 times.

28.3 The following are considered to comply with the requirements in 28.1:

- a) An automatic household flatiron employing a temperature control that has been investigated and found to be acceptable for 30000 cycles of operation, and
- b) An automatic commercial flatiron employing a temperature control that has been investigated and found to be acceptable for 100000 cycles of operation.

## 29 Normal temperature test

### 29.1 General

29.1.1 A flatiron, when tested as described in 29.2.1-29.2.12, shall not attain a temperature at any point high enough to cause a risk of fire, to damage any material used in the flatiron, or exceed the temperature rises specified in table 29.1. The nameplate of the flatiron shall not melt or be seriously damaged.

**Table 29.1**  
**Maximum acceptable temperature rises**

| Materials and components   | Degrees |       |
|--|---------|-------|
|  | C       | (F)   |
| 1. At any point within a terminal box or wiring compartment of a permanently connected flatiron in which field –installed conductors are to be connected, including such conductors themselves, unless the flatiron is marked in accordance with 47.8. | 35      | (63)  |
| 2. At any point on a surface adjacent to the stationary portion of a permanently connected flatiron, including the surface on which the flatiron is mounted.   | 65      | (117) |
| 3. Fiber employed as electrical insulation   | 65      | (117) |
| 4. Wood or other combustible material  | 65      | (117) |
| 5. Class 105 insulation systems on relay or solenoid windings:   | 65      | (117) |
| Thermocouple method <sup>a</sup>   | 65      | (117) |
| Resistance method  | 85      | (153) |

Table 29.1 continued on text page

**Table 29.1 Continued**

| Materials and components   | Degrees                                     |       |
|--|---|-------|
|  | C   | (F)   |
| 6. Class 130 insulation system:  |   |       |
| Thermocouple method <sup>a</sup>   | 85  | (153) |
| Resistance method  | 105   | (189) |
| 7. Flatiron or appliance plug  | 175   | (315) |
| 8. Insulation wire or cord (b)   | 25°C(77°F) less than its temperature rating |       |
| 9. Copper conductors, bare or insulated, without a coating or other equivalent protection.   | 125   | (225) |
| 10. Termination of copper conductor and pressure terminal connector without a nickel coating or other equivalent protection  | 125   | (225) |
| 11. Phenolic composition used as electrical insulation or relied upon to reduce the risk of fire or electric shockc  | 125   | (225) |
| 12. Flatiron handle <sup>d,e,f</sup>   |   |       |
| a) Metallic  | 30  | (54)  |
| b) Nonmetallic <sup>g</sup>  | 50  | (90)  |
| 13. A part near a handle that is likely to be contacted unintentionally <sup>d, e, f, h, l</sup>   |   |       |
| a) Metallic  | 35  | (63)  |
| b) Nonmetallic <sup>g</sup>  | 60  | (108) |
| 14. A knob, a grip, and the like that, in normal use, is held only for short periods, for example, a switch or thermostat adjustment <sup>d, e, f, l</sup>   |   |       |
| a) Metallic  | 35  | (63)  |
| b) Nonmetallic (g)   | 60  | (108) |
| 15. Polymeric enclosures other than of phenolic composition <sup>j</sup>   | 55  | (99)  |
| <sup>a</sup> At a point on the surface of a coil where the temperature is affected by an external source of heat, the temperature rise measured by means of a thermocouple may be higher than the maximum value specified by the following amount: |   |       |
| Item   | additional temperature rise                 |       |
| 5  | 15°C(27°F)                                  |       |
| 6  | 20°C(36°F)                                  |       |
| Provided that the temperature rises of the coil, as measured by the resistance method, is not more than that specified, see 29.2.12.   |   |       |

Table 29.1 continued on text page

Table 29.1 Continued

| Materials and components  | Degrees |     |
|---|---------|-----|
|   | C       | (F) |
| <sup>b</sup> See 29.4.2<br><sup>c</sup> See 43.4.1<br><sup>d</sup> For an automatic flatiron, these temperature are to be measured with the flatiron on its stand and with the temperature control adjusted to produce the average maximum soleplate temperature but not greater than an average maximum temperature of 204°C(400°F)<br><sup>e</sup> In determining the temperature raises f a handle, a knob, a grip, and the like, consideration is to be given to all portions of these parts that are gripped in normal use<br><sup>f</sup> With respect to temperature rise, a handle, a knob, a grip, or the like that is made of nonmetallic material, and plated or clad with metal is considered a nonmetallic part: <ol style="list-style-type: none"> <li>1) If the thickness of metal is 0.005 in (0.13mm) or less, or</li> <li>2) If the coefficient of thermal conductivity of the part is not greater than 2.419 btu per hour per foot per degree Fahrenheit see 29.2.13.</li> </ol> <sup>g</sup> The temperature limits normally applied to the specified materials apply at the areas in contact with hot metal.<br><sup>h</sup> See 29.3.1 and 29.3.2.<br><sup>i</sup> These temperature limits are not applicable to commercial flatirons,<br><sup>j</sup> See 43.4.2. |         |     |

29.1.2 the maximum temperature of a sealing compound when corrected to a 25°C ambient temperature, shall be 15°C(27°F) less than the softening point of the compound as determined by the Test for Softening Point by Ball-and-Ring Apparatus, ASTM E 28-67 (1982).

29.1.3 there is no temperature limit applicable to glass fiber or beads of ceramic material.

## 29.2 Procedure

29.2.1 One sample of a flatiron is to be tested to determine whether it complies with the requirements in 29.1.1 this sample is to be the one having the highest average temperature during the repeated soleplate temperature test required by 27.1.1(b).

29.2.2 All values for temperature rises in table 29.1 are based on an assumed ambient temperature of 25°C (77°F); however, tests may be conducted at any ambient temperature within the range of 20 -30°C (68- 86°F).

29.2.3 A nonautomatic flatiron is to be operated continuously until constant temperature have been reached.

29.2.4 An automatic flatiron is to be operated through the initial period described in 26.1(a). A flatiron with an adjustable temperature control is to be operated with the control set to give the highest temperature values.

29.2.5 A cordless flatiron is to be operated in its power stand until the thermostat opens. The flatiron is to be removed from the power stand and supported as described in 26.4 until the thermostat closes. This cycle is to be repeated until constant temperatures are attained .see 29.2.9.

29.2.6 A commercial steam flatiron in which steam is supplied from an external source is to be operated under the normal operating conditions that produce the highest temperatures.

29.2.7 A flatiron is to be operated at the voltage specified in 23.6 and 23.7 except that the test voltage is to be increased, if necessary, so that the wattage input is equal to the wattage rating marked on the flatiron.

29.2.8 For the normal temperature test, the flatiron is to be supported as described in 26.4.

29.2.9 For tests that are to be continued until constant temperatures are attained, thermal equilibrium is consider to exist only if three successive readings indicate no change when taken at the conclusion of each of three consecutive equal intervals of time, the duration of each interval being 10 percent of the total test time elapsed before the start of the first interval but not less than 5 min.

29.2.10 Other than as noted in 29.2.12, temperature are to be measured by thermocouples consisting of wires not larger than 24AWG ( $0.21\text{mm}^2$ ) and not smaller than 30AWG ( $0.05\text{mm}^2$ ). When thermocouples are used in determining temperature in electrical equipment, it is common practice to employ thermocouples consisting of 30AWG iron and constantan wire and a potentiometer –type instrument; and such equipment is to be used whenever referee temperature measurements by thermocouples are necessary. The thermocouples and related instruments are to be accurate and calibrated in accordance with good laboratory practice. The thermocouple wire is to conform with the requirements listed in the Initial Calibration Tolerances for Thermocouples Table in Temperature-measurement thermocouples, ANS/ISA MC96.1.

29.2.11 A thermocouple junction and adjacent thermocouple lead wire are to be securely held in good thermal contact with the surface of the material the temperature of which is being measured. In most cases, adequate thermal contact will result from securely taping or cementing the thermocouples in place but, if a metal surface is involved, brazing or soldering the thermocouple to the metal may be necessary.

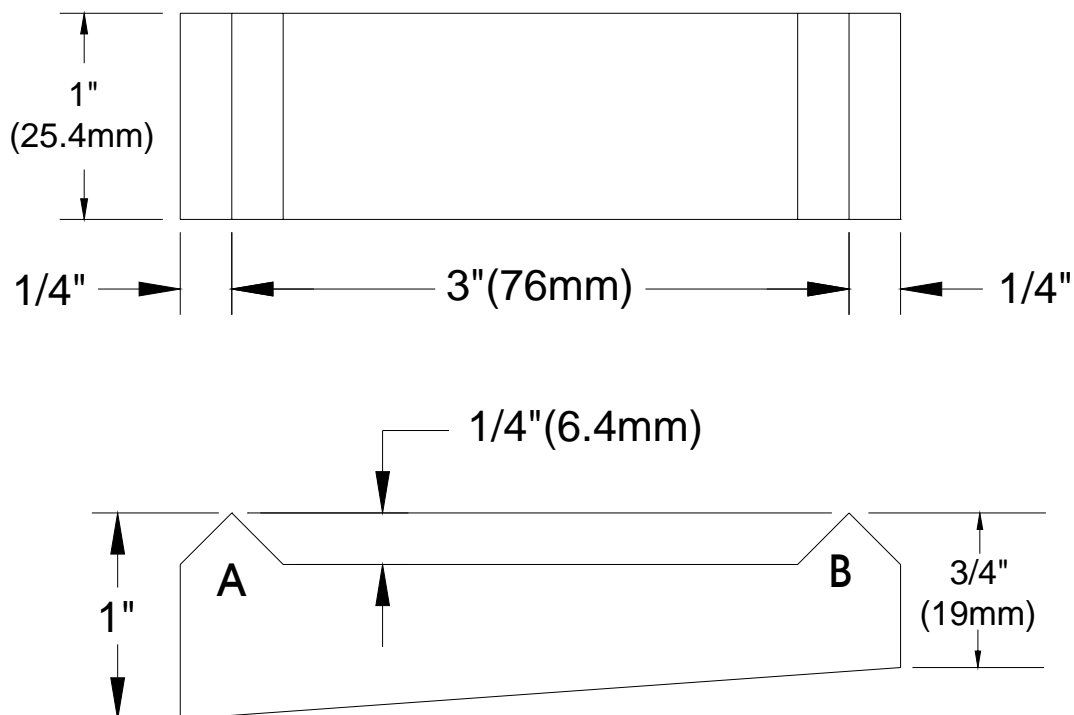
29.2.12 Usually, the temperature of a coil or winding is to be measured by means of thermocouples mounted on the outside of the coil wrap. If the coil is inaccessible for mounting thermocouples – for example, a coil immersed in sealing compound – or if the coil wrap includes thermal insulation or more than  $1/32$  in ( $0.8\text{mm}$ ) of cotton, paper, rayon, or similar insulation, the change-of-resistance method is to be used.

29.2.13 With reference to note (f) of table 29.1, the thermal conductivity of a material may be obtained by comparison with materials having known thermal conductivities. Samples of materials with known values of the constant and a sample of the materials of which the thermal conductivity is to be determined -all samples having the same dimensions-are fixed to a heated metal plate. The temperatures of the faces of the reference samples opposite the heated metal plate are plotted as a function of the constant. The constant to be determined is derived from this curve by reading the value corresponding to the temperature attained by the sample under investigation.

### 29.3 Parts near handle

29.3.1 Parts likely to be contacted unintentionally include those parts within 1/2 in (12.7mm) of the bottom surface of a gauge constructed as illustrated in figure 29.1, when the gauge is centered in the handle opening as illustrated in figure 29.2 (C=D). For a handle having one end open, the end of the gauge is to be located 2 in (50.8mm) from the inside surface of the closed end. If the shape of the underside of the handle prevents contact of the gauge at both points A and B simultaneously measurements are to be made first with one point and then with the other point in contact with the underside of the handle.

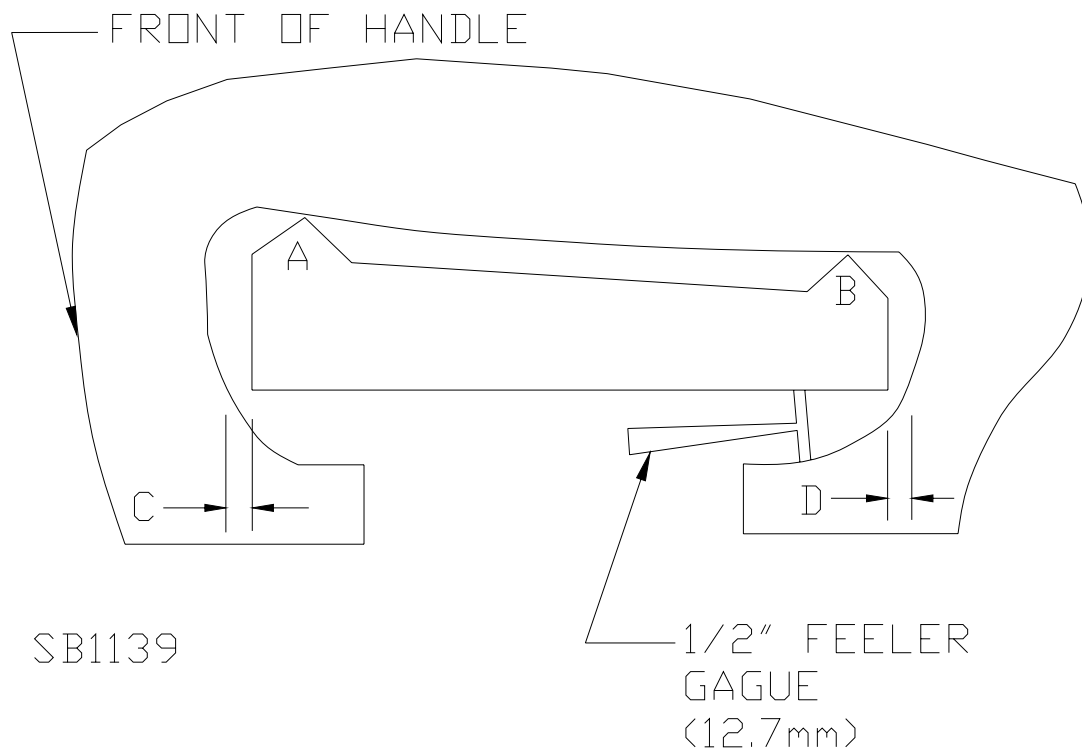
Figure 29.1  
Gauge



S1138

29.3.2 a part is not considered likely to be contacted unintentionally if it is recessed or set back 1/8 in (3.2mm) or more from an opening having at least one dimension not larger than 3/8 in (9.5mm).

**Figure 29.2**  
**Application of gauge**



#### 29.4 Wire and cord

29.4.1 If retention of the insulation on a heater cord depends upon a fabric braid, the braid shall not be removed nor subjected to a temperature rise of more than 65°C(117°F) unless other means is provided to hold the insulation in place. If the protection provided by the jacket of type HSJ or HSJO cord is required, the jacket shall not be subjected to a temperature rise of more than 35°C(63°F).

29.4.2 Inside a flatiron, the temperature rise on a wire or cord may be greater than the maximum rise specified in table 29.1 if the insulation is protected by supplementary insulation on each individual conductor; such as a braid, wrap, tap or close-fitting tubing, that is acceptable for the temperature and the type of insulation involved.

29.4.3 Treatment such as those mentioned in 29.4.2 or the use of an impregnant may be acceptable for retaining insulation on the conductor of a heater cord at elevated temperature.

### **29.5 Surface temperature**

29.5.1 The surface on which a flatiron is operated as described in 29.5.2 shall not reach a temperature of more than 200°C (392°F), and the nameplate of the flatiron shall not melt or be seriously damaged.

29.5.2 To determine whether a flatiron complies with the requirements in 29.5.1, it is to be operated on its stand on a padded softwood surface as described in 26.7. A nonautomatic flatiron is to be operated until constant temperatures have been reached, and an automatic flatiron I to be operated through an initial period as described in 26.1 (a).

### **30 Dielectric voltage – withstand test**

30.1 A flatiron shall withstand for 1 min without breakdown the application of a 60-Hz essentially sinusoidal potential between live parts and dead metal parts. The test potential shall be:

- a) 1000 v for a flatiron rated 250 V less.
- b) 1000 v plus twice the rated voltage for a flatiron rated more than 250 V.

30.2 To determine whether a flatiron complies with the requirement in 30.1, a thoroughly heated flatiron is to be tested by means of a 500 VA or larger transformer, the output voltage of which is essentially sinusoidal and can be varied. Starting at zero, the applied potential is to be increased until the required test potential is reached or until breakdown occurs. The increase in applied potential is to be at a substantially uniform rate and as rapid as is consistent with its value being correctly indicated by a voltmeter. The test potential is to be maintained for 1 min.

### **31 Test for security of blades on cordless flatirons**

31.1 There shall be no loosening of the blades, or residual displacement of the blades of more than 3/32 in (2.4mm) of a cordless flatiron when measured 2 min after the test specified in 31.2.

31.2 The flatiron is to be supported on a horizontal steel plate with the blades, pins, or both projecting downward through a single hole that will permit the blades, pins, or both to pass through it. A weight that exerts a force of 20 lbf (89N) is to be supported by each blade or pin in succession. The pull is to be gradually applied.



## 32 Overload test

### 32.1 Automatic flatirons

32.1.1 There shall be no electrical or mechanical breakdown of the electrical control device of an automatic flatiron or undue pitting, burning, or welding of the contacts when tested as described in 32.1.2 and 32.1.3.

32.1.2 Unless investigated and found acceptable for the application, the electrical control of an automatic flatiron is to be operated for 50 cycles of making and breaking the circuit as follows:

- a) A flatiron rated 125V or less is to be connected to a supply circuit having a voltage of 120 percent of the rated voltage of the flatiron.
- b) The electrical control of a flatiron rated more than 125V is to be connected to a supply circuit loaded to 150 percent of the current drawn by the appliance at its maximum rated voltage.

### 32.2 Cordless flatirons

32.2.1 A cordless flatiron shall remain capable of functioning as intended without undue burning or pitting of the contacts when tested as described in 32.2.2 and 32.2.3.

*Exception: The contacts of a cordless flatiron that comply with the applicable requirements in the Standard for Attachment Plugs and Receptacles, UL 498, or the Standard for Special-Use Switches, UL 1054, need not comply with this requirement.*

32.2.2 A flatiron is to be tested by inserting and withdrawing the flatiron into its power stand. The flatiron is to make and break 150 percent of the rated current for 50 cycles of operation at a rate 6 – 10 cycles per minute. The blade of the flatiron is to mate with the female contact of the power stand for no more than 1 s.

32.2.3 The power stand is to be connected to a 120 - V, 60Hz source of supply in series with a resistive load. The load is to be adjusted to produce 150 percent of rated current.

### 33 Endurance test for cordless flatirons

33.1 In addition to complying with the overload test, section 32, the same cordless flatiron shall remain capable of functioning as intended without undue burning or pitting of the contacts when tested as described in 33.2.

*Exception: The contacts of a cordless flatiron that comply with the applicable requirements in the Standard for Attachment Plugs and Receptacles, UL 498, or the Standard for Special-Use Switches, UL 1054, need not comply with this requirement.*

33.2 For the test, the resistive load specified in 32.2.3, is to be adjusted to produce 100 percent of rated current. The flatiron is to make and break rated current for 6000 cycles of operation at a rate 6 –10 cycles per minute.

### 34 Resistance to moisture test

34.1 After conditioning as described in 34.2, a flatiron employing insulation likely to be adversely affected by moisture under conditioning of normal use shall:

- a) Comply with the requirements for leakage current specified in section 24, Leakage Current Test, except that the supply voltage is to be rated voltage and the test may be discontinued when the leakage current stabilizes.
- b) Comply with the dielectric voltage-withstand requirements in 30.1.

34.2 A flatiron as mentioned in 34.1 is to be conditioned for 24 h in air having a relative humidity of 85 ±5 percent at a temperature of 32±2 °C (90 ± 4°F ).

34.3 If deterioration of tubing, sealant, gasket material, or the like would permit moisture to contact a live part or a heating element, the performance tests shall not result in deterioration or excessive hardening of the sealant, gasket material, and the like.

### 35 Tests on automatic reset controls

35.1 An indicator, as mentioned in 17.2.2, shall not function during the normal temperature test, section 29.

### **36 Tests on indicator lights**

36.1 If a light is used as an indicator as mentioned in 17.2.2, it shall withstand, without burning out or failing to light, a 6000 cycles endurance test with each cycle consisting of 1 min in and 30 s off.

### **37 Abnormal operation test**

#### **37.1 Overfill**

37.1.1 A steam flatiron is to be conditioned as described in 37.1.1. After conditioning:

- a) Leakage current shall not exceed 5 mA, measured in accordance with 24.3 – 24.8, except that the supply voltage is to be rated voltage and the test is to be discontinued when the leakage current stabilizes; and
- b) The flatiron shall comply with the dielectric voltage – withstand test, section 30.

37.1.2 A steam flatiron is to be conditioned by carefully filling the reservoir with tap water up to the mouth of the filler opening, without overflowing; then, with the flatiron at any angle up to 20 degrees from the normal filling position, an additional 150 cc of water is to be poured into the filler opening through an orifice having a diameter of 3/8 in (9.5mm). The additional water poured into the filler opening is to be allowed to spill over the flatiron. With the filler opening remaining open and with the soleplate in a horizontal position, the flatiron is to be rapidly rotated back and forth through an angle of 90 degrees about a vertical axis through its heel, through five complete cycles of motion. The position and motion of the flatiron need only approximate the foregoing specifications. Immediately thereafter, the required tests are to be conducted.

#### **37.2 Overtemperature**

37.2.1 A flatiron shall be tested as described in 37.2.2 – 37.2.5. None of the following shall result:

- a) Emission of flame or molten metal from the flatiron – blistering is not considered to be molten metal;
- b) Glowing or flaming of the padded test stand;
- c) Opening of the branch – circuit overload – protective device;
- d) Short-circuiting or grounding the enclosure of live parts by the opening of a protective device provided with the flatiron;
- e) Opening of the fuse to ground;
- f) A leakage current exceeding 5 mA; or
- g) Deformation of the enclosure that would allow access to live parts using the probe illustrated in Figure 7.2.

37.2.2 For a flatiron provided with a temperature control, the temperature control is to be by-passed by means of a 14AWG (2.1mm<sup>2</sup>) copper conductor or the equivalent, installed so that it does not otherwise affect the movement of operating parts of the temperature control and does not itself become grounded during the test.

37.2.3 Two flatirons are to be used for the tests required by 37.2.1. One flatiron is to be tested with soleplate resting on sheet steel nominally 0.060 in (1.52mm) thick that is supported as described in 26.2. The other flatiron is to be tested resting on its heel rest on a padded test stand as described in 26.7. The enclosures are to be connected through a 3 –A fuse to ground. The flatirons are to be operated continuously at the voltage specified in 23.6 and 23.7 in a draft – free environment for a minimum of 7h or until ultimate results (such as permanent opening of an overcurrent or overtemperature protective device) are obtained. The tests are to be repeated twice, totaling six tests. A new protective device or a new flatiron may be used for each test.

37.2.4 Following the tests described in 37.2.3, with the sample in the heated condition, the sample is to be moved to the opposite position and then back to the original position and the leakage current test repeated. If a serviceable part, such as a resettable or replaceable backup protective device, has opened the circuit, the device is to be reset or replaced and the complete leakage current test is to be conducted in accordance with 24.7. If a non-serviceable part has opened the circuit, the leakage current test is to be conducted immediately after the part opens. Only the test described in 24.7 (a) need be conducted and the leakage current shall not exceed 5 mA.

37.2.5 Following the repeated leakage current test prescribed in 37.2.4, the enclosure shall comply with 7.8.

### **37.3 Dual voltage appliance**

37.3.1 A dual voltage appliance shall be subjected to the test described in 37.3.2. The acceptance criteria is outline in 37.2.1? There shall be no electrical or mechanical breakdown of the voltage selector switch.

37.3.2 The flatiron is to have its voltage selector switch set at one of its voltage settings, and then connected to a supply circuit rated at the other marked voltage. If the marked voltage falls within one of the following voltage ranges: 100- 120, 220 –240, 254 –277, or 440 –480, the test voltage is to be the highest voltage ranges. The combination of the voltage selector switch setting and the supply circuit voltage is to be that which develops the most severe operating conditions.

### 37.4 Components

37.4.1 A risk of fire, electric shock, or injury to persons shall not result, when a flatiron employing solid-state components is tested as described in 37.4.2 – 37.4.4. During the test, a flatiron shall not emit flame or molten metal other than drops of melted solder, and there shall be no glowing or flaming of combustible material upon which the appliance may be placed or that may be in proximity to a permanently installed appliance.

37.4.2 If a flatiron uses one or more solid – state device such as a rectifier, a transistor, a resistor, or a similar component, a risk of fire, electric shock, or injury to persons shall not result when the circuit between any two terminals of any such component is opened or shorted. If the flatiron uses a capacitor in combination with one of the above – specified components, a risk of fire, electric shock, or injury to persons shall not develop when the capacitor is short-circuited. Only one of the simulated fault conditions describe is to be imposed at one time. Exposed dead metal parts of the appliance are to be connected to ground through a 3 A fuse, and the results are acceptable if the fuse does not rupture during the test. During the test operations, the flatiron is to be supported as described in 26.4 with a double layer of cheesecloth draped over the area containing the solid-state components.

*Exception: A wire – wound resistor need not be shorted.*

37.4.3 Unless ultimate results (such as the permanent opening of an overcurrent or overtemperature protective device) are obtained, the flatiron is to be operated for a minimum of 7h for each test.

37.4.4 Short-circuit tests for determining whether a flatiron complies with the requirements in paragraph 37.4.2 are to take into account the intended usage of the flatiron. For example, if the flatiron is provided with a momentary contact switch having no provision for being locked in the ON position, and if there is indication of malfunction (abnormal operation of the flatiron, failure of the flatiron to operate in the intended manner, or other indication), the test is to be discontinued when the malfunction becomes evident. Otherwise, the test is to be continued for 7h or until ultimate results occur.

### 38 Stability test

38.1 A flatiron having an integral or attached stand shall not overturn and a flatiron provided with a separate stand should neither overturn nor slip off the stand when tested as described in 38.2 and 38.3.

38.2 One undamaged flatiron is to be subjected to the stability test. A steam flatiron is to be tested once with the reservoir empty and once with the reservoir full.

38.3 The flatiron is to be placed on its stand, as intended, on a hard, plane surface inclined at an angle of 10 degrees from the horizontal. The cord is to rest on the inclined plane in the most unfavorable position.

### 39 Cord flexing

39.1 To determine whether the cord and cord guard mentioned in 12.2.2.1 are acceptable, the tests described in 39.2 –39.4 are to be conducted. During the test, the cord shall not develop an open circuit, and there shall be no exposure of an uninsulated conductor strand.

*Exception: The power stand of a cordless flatiron need not be tested.*

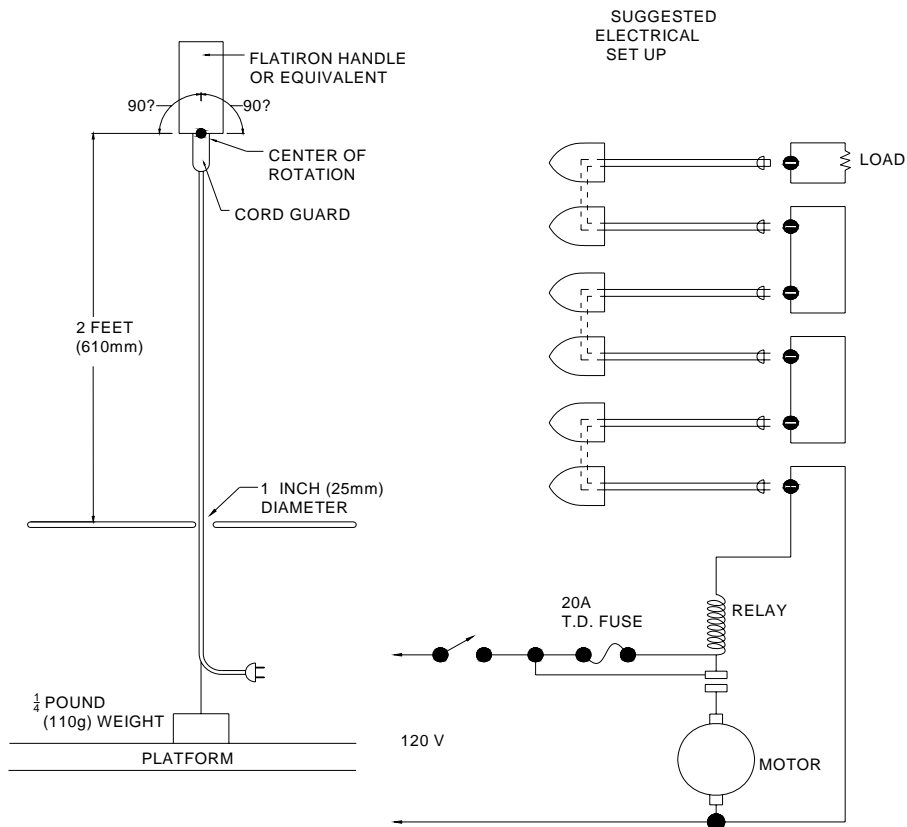
39.2 To conduct the flexing test referred to in 39.1, six assemblies of the cord and cord guard are to be assembled to flatirons, simulated mounting surfaces, or test – fixtures, so as to not interfere with the test procedure. Each assemblies is to be mounted so that rotation is centered at the point where the guard enters the unit. See figure 39.1. For the start of the test, the axis of the cord guard is to be positioned vertically with the cord end down. The cord is to be passed through a horizontal bushing having a smoothly rounded 1- in (25.4mm) diameter opening, located 2 ft (610mm) below the cord guard entry to the flatiron. The free end of the cord is to be attached to a 1/4- lb (110g) unsupported weight. One or more complete flatirons of the maximum rating intended for use with the cord and with the thermostat by-passed are to be used as the electrical load, or the leads for each assembly that are normally connected to the heating elements are to be connected to a load that draws the same current. The supply end of the cord is to be connected to a 120-v circuit protected by a 20-A time –delay fuse. One of more series current relays are to be provided to shut down the machine if a conductor opens. The six assemblies are to be flexed for 50000 cycles through an angle of approximately 180 degrees, as illustrated in figure 39.1, by a machine at a rate of approximately 20 cycles per minute, unless faster cycling is agreeable to those concerned.

39.3 With reference to 39.2, one cycle consists of 90 -degree rotation of the test assembly in one direction, 180 – degree rotations in the opposite direction and then returns to the starting point. Flexing through an angle of 90 degrees in one direction only and return to the starting point is acceptable if the number of cycles is doubled and the flexing is changed to the opposite direction after each 10,000 cycles.

39.4 Six additional samples are to be assembled to flatirons, simulated mounting surfaces, or test-fixtures so as to not interfere with the test procedure and subjected to the conditioning and flexing test described in 39.5. During the test, the cord shall not develop an open circuit, and there shall be no exposure of an uninsulated conductor strand. Following the test there shall be no visible cracks in the cord or cord guard.

39.5 To conduct the test required by 39.4, the cord and cord guard are to be conditioned for 96h in an oven maintained at a temperature of 20°C(36°F) more than the maximum temperature observed on the cord or cord guard during the temperature test, but not less than 100°C( 212°F). Following the conditioning, the assemblies are to be flexed for 5000 cycles in the manner described in 39.3.

**Figure 39.1**  
**Cord flexing test**



**40 Strain relief test**

40.1 The strain relief means on an attached flexible cord shall withstand for 1 min a pull of 20lbs (89N) applied to the cord with the connections within the flatiron disconnected. The strain relief is not acceptable if, at the point of disconnection of the conductors, there is such movement of the cord as to indicate that stress would have resulted on the connections.

40.2 A 20-lb (9-Kg) weight is to be suspended on the cord and supported by the flatiron so that the strain-relief means will be stressed from any angle that the construction of the flatiron permits.

40.3 In addition to complying with the test requirements in 40.1 and 40.2, the same strain-relief means shall withstand the drop test described in 40.4, without deformation of the anchoring surface if this would result in a risk of fire or electric shock, such as cutting insulation or cracking or chipping the bushing. The strain relief is not acceptable if, at the point of disconnection of the conductors, there is such movement of the cord as to indicate that stress would have resulted on the connections.

40.4 The sample is to be suspended by the line cord so that the distance from the point of support to the point of entry of the cord into the flatiron is 2 ft (610mm). The flatiron is to be raised until the cord entry reaches the support plane and is then to be dropped.

40.5 A power-supply cord shall withstand for 1 min, a torque of 50 in-oz (0.35N · m) applied to the cord 1 in (25.4mm) from the outer end of the cord guard through which the cord exits without damage to the cord and without transmitting stress to the terminations. The torque is to be applied in a manner that would tend to twist the cord around its axis.

#### **41 Push-back relief test**

41.1 To determine compliance with 12.2.4.1, a product shall be tested in accordance with 41.2 without occurrence of any of the conditions specified in 12.2.4.1 (a) - (d).

41.2 The attached flexible cord is to be held 1 in (25.4mm) from the point where the cord emerges from the flatiron and is then to be pushed back into the flatiron. The cord is to be pushed back into the flatiron in 1-in (25.4mm) increments until the cord buckles or the force to push the cord into the flatiron exceeds 6 lbf (26.7N). The cord within the flatiron is to be manipulated to determine compliance.

*Exception: If an integral cord guard is provided, the push-back force is to be applied 1 in from the end of the cord guard*

#### **42 Permanence of marking**

42.1 A pressure sensitive label or a label that is secured by cement or adhesive and that provides a marking that is required shall be tested as described in 42.2 – 42.5 unless it has been investigated and found to be acceptable for the application. The label is considered to be of a permanent nature if immediately following removal from each test medium, and after being exposed to room temperature for 24 h following removal from each medium:

- a) Each sample demonstrates acceptable adhesion and the edges are not curled.
- b) The label resists removal as demonstrated by scraping across the test panel with a flat metal blade that is 1/32 in (0.8mm) thick by 2 in (50.8mm) wide. The blade is to be held at right angles to test panel and is to be scraped across the label and panel ten times with a force of approximately 2 lbf (9 N).
- c) The printing is legible and is not defaced by rubbing with thumb or finger pressure.

42.2 OVEN-AGING TEST – Three samples of the label applied to test surfaces in the intended application are to be conditioned for 240 h in an air oven maintained at the temperature specified in table 42.1.



**Table 42.1**  
**Temperature, oven – aging**

| Maximum temperature during normal temperature test of surface to which applied |               | Oven temperature |       |
|--|---------------|------------------|-------|
| °C   | (°F)          | °C               | (°F)  |
| 60 or less   | (140 or less) | 87               | (189) |
| 80 or less   | (176 or less) | 105              | (221) |
| 100 or less  | (212 or less) | 121              | (250) |
| 125 or less  | (257 or less) | 150              | (302) |
| 150 or less  | (302 or less) | 180              | (356) |
| Over 150   | (Over 302)    | a                |       |

<sup>a</sup> A label that is applied to a surface attaining a temperature greater than 150°C (302°F), during the normal temperature test, is to be oven-aged at a temperature representative of the temperature attained by the appliance during normal and abnormal operation.

42.3 IMMERSION TEST – Three samples of the label applied to test surface as in the intended application are to be conditioned for 24 h in a controlled atmosphere maintained at 23±2°C (73±4°F) at a relative humidity of 50±5 percent. The samples are then to be immersed for 48 h in water at a temperature of 21±2°C(70±4°F).

42.4 STANDARD – ATMOSPHERE TEST- Three samples of the label applied to test surfaces as in the intended application are to be conditioned for 72 h in a controlled atmosphere maintained at 23±2°C(73 ±4°F) at a relative humidity of 50±5 percent.

42.5 UNUSUAL – CONDITION EXPOSURE TEST- Three samples of label that are exposed to unusual conditions in service – such as spray starch, and the like – are to be applied to test surfaces as in the intended application and conditioned for 24 h in a controlled atmosphere maintained at 23±2°C(73±4°F) at a relative humidity of 50±5 percent. The samples are then to be immersed for 48 h in a solution representative of service use maintained at the temperature the solution would reach in service, but not less than 23±2°C(73±4°F).

### 43 Polymeric material tests

#### 43.1 General

43.1 A polymeric enclosure shall comply with the requirements in 43.1 – 43.4.

*Exception: The requirement does not apply if:*

- a) All live parts within the enclosure are insulated or provided with internal enclosures that are independent of the outer enclosure;*
- b) All leads connecting components inside the enclosure are mechanically secured so that displacement of any component resulting from distortion of the outer enclosure will not cause a stress on the junction between a lead and a terminal of the component – see 43.1.4; and*
- c) The power –supply-cord strain relief does not depend upon the enclosure.*

43.1.2 A phenolic part, other than an enclosure, that supports an uninsulated live part shall comply with the requirements in 43.2.1 – 43.2.3, 43.4.1, and 43.4.3 – 43.4.5.

43.1.3 A polymeric part, other than a phenolic part as specified in 43.1.2, that supports an uninsulated live part shall comply with the relative requirements based on the part's application as prescribed in Material properties considerations in the standard for Polymeric Material – Use in Electrical Equipment Evaluations, UL 746C.

43.1.4 With reference to item (b) of the exception to 43.1.1, an integral lead of a component shall be provided with acceptable strain relief, as determined by test.

#### **43.2 mold- stress evaluation**

43.2.1 Three flatirons are to be conditioned as described in 43.2.2. After conditioning and immediately following removal from the oven, there shall be no softening of the material, as determined by handling. After cooling to room temperature, each flatiron is to be examined with reference to the following:

- a) There shall be no cracking of the material;
- b) There shall be no exposure of uninsulated live parts to the extent that the product would not comply with the requirements specified in 7.7 – 7.9; and
- c) There shall be no warping or distorting to the extent that the flatiron will not comply with the requirements in section 40, strain relief test.

43.2.2 Three flatirons are to be placed in an oven for 7 h at 10°C(18°F) higher than the maximum operating temperature of the material measured under normal operating conditions, but not less than 70°C (158°F).

*Exception: The strain relief means may be investigated on separate flatirons that have been placed in an air circulating oven for 7 h at 10°C higher than the maximum operating temperature of the polymeric material at the strain relief means, but not less than 70°C.*

43.2.3 Crazeing of the polymeric material is acceptable.

### 43.3 Flame resistance

#### 43.3.1 General

43.3.1.1 When tested in accordance with 43.3.1.2 – 43.3.1.4 and 43.3.6 or 43.3.7, an enclosure or a decorative part made of polymeric material shall not flame for more than 1 min after two 30-s applications of a test flame, with an interval of 1 min between applications of the flame. Also, the sample shall not be completely consumed.

*Exception No. 1: An enclosure molded from a material that is classed as 5VA, 5VB, V-0, V-1, or V-2 by the vertical burning tests described in the standard for tests for flammability of plastic materials for parts in devices and appliances, UL 94, need not be tested.*

*Exception no. 2: A decorative part that is molded from a material that is classed as 5VA, 5VB, V-0, V-1, V-2, or HB by the burning tests described in UL 94, need not be tested.*

*Exception no. 3: A decorative part need not be subjected to this test, if it:*

- a) Does not occupy a volume greater than 0.122 in<sup>3</sup> (cm<sup>3</sup>),*
- b) Does not have any dimension greater than 1.18 in (3cm), and*
- c) Is located so it cannot propagate flame from one area to another or bridge between a possible source of ignition and other ignitable parts.*

43.3.1.2 Flame –retardant coating or paints shall not be employed to accomplish compliance with the requirements in 43.3.1.1.

43.3.1.3 Three samples of the enclosure are to be placed in an oven for 7 days at a uniform temperature not less than 10°C(18°F) higher than the maximum temperature of the material measured under normal operating conditions, but not less than 90°C(194°F). After cooling to room temperature, the samples are to be tested in accordance with 43.3.1.4 and 43.3.6.1 or 43.3.7.1.

*Exception: The test described in 43.3.1.4 and 43.3.6.1 or 43.3.7.1 may be conducted on unconditioned samples if:*

- a) The enclosure material has been determined previously, by a long- time thermal- aging program, not to show a reduction in its flame –resistant properties as a result of this aging, and*
- b) Such an aging program included specimens at least as thin as the wall of the enclosure.*

43.3.1.4 Three samples of the enclosure of the flatiron most likely to be ignited are to be selected. The sections most likely to be ignited are considered to be those adjacent to splices, open – type switches, or other arcing or sparking parts. With a different sample in each case, each of such sections is to be subjected to the flame test described in 43.3.6.1 or 43.3.7.1. During the test, the flatiron is to be supported in its normal operating position in a draft- free location, and nonpolymeric portions of the enclosure in contact with or fastened to the polymeric portions are not to be removed; and insofar as possible, the internal mechanism of the flatiron is to be in place.





#### 43.3.6 3/4 in-flame test

43.3.6.1 A Bunsen burner having a tube length of  $3.94 \pm 0.39$  in ( $100 \pm 10$ mm) and an inside diameter of  $0.374 \pm 0.012$  in ( $9.5 \pm 0.3$ mm) is to be adjusted to have a 3/4 in (19.1mm) yellow flame with no blue cone. Two 30s applications to the tip of the flame are to be made to each section of the enclosure selected as described in 43.3.1.4 with a 1- min interval between the applications. A supply of technical – grade methane gas is to be used with a regulator and meter for uniform gas flow.

Exception: Natural gas having a heat content of approximately  $37 \text{MJ/m}^3$  ( $1000 \text{ But /ft}^3$ ) at  $23^\circ\text{C}$  has been found to provided similar and may be used.

#### 43.3.7 12 mm-flame test

43.3.7.1 The burner to produce the flame consists of a tube at least 1.5 in(35mm) long having an inside diameter of  $0.02 \pm 0.005$  in ( $0.5 \pm 0.1$ mm)and an outer diameter not exceeding 0.05 in (0.9mm). The burner shall not have air ports. The gas supply shall be butane having a purity of least 95 percent, and a heat content of approximately  $3300 \text{Btu/ft}^3$  ( $122 \text{ MJ/m}^3$ ).

43.3.7.2 With the axis of the burner in a vertical position, the gas supply is to be adjusted so that a 0.5-in (12mm) flame is produced. Two 30-s applications of the tip of the flame are to be made to each section of the equipment, selected as indicated in 43.3.1.4, with a 1- min interval between the applications.

### 43.4 endurance

43.4.1 An enclosure or a part of phenolic composition enclosing or supporting an uninsulated live part, and operating at a temperature of more than  $150^\circ\text{C}$  ( $302^\circ\text{F}$ ) is acceptable if:

- a) The material has been investigated and found acceptable for the temperatures involved, or
- b) After operation, as specified in 43.4.3 – 43.4.5, the part or enclosure does not crack or show other evidence of deterioration that may greatly reduce the strength of the part or enclosure; and
- c) After cooling to room temperature, there is no evidence of leakage of water onto live parts or components detrimentally affected by moisture when the water reservoir is filled.

43.4.1 revised February 18,2004

43.4.2 A polymeric enclosure, other than as specified in 43.4.1, operating at a temperature of more than  $80^\circ\text{C}$ ( $176^\circ\text{F}$ ) is acceptable if:

- a) The material has been investigated and found acceptable for the temperatures involved, or
- b) After operation, as specified in 43.4.3- 43.4.5, the enclosure does not crack or show other evidence of deterioration that may greatly reduce the strength of the part or enclosure; and
- c) After cooling to room temperature, there is no evidence of leakage of water onto live parts or components detrimentally affected by moisture when the water reservoir is filled.

43.4.2 revised February 18,2004



43.4.3 When tested as specified in 43.4.5, an automatic flatiron is to be operated with all temperature controls bypassed.

43.4.4 During the test specified in 43.4.5, the input voltage of a flatiron is to be adjusted so that the polymeric part or enclosure is subjected to the maximum temperature obtained during the tests specified in section 29, Normal Temperature Test.





No Text on This Page

43.4.5 A cordless flatiron with a phenolic part or a polymeric enclosure is to be operated continuously in its power stand for 1000 h. any other type of flatiron with a phenolic part or a polymeric enclosure of a flatiron is to be operated on its stand for 336 h and, then, on its face for 664 h.

## MANUFACTURING AND PRODUCTION TESTS

### 44 Dielectric voltage – withstand test

44.1 Each flatiron shall withstand without electrical breakdown, as a routine production-line test, the application of a 40- 70 Hz potential:

- a) Between the primary wiring and accessible dead metal parts that could become energized, and
- b) Between primary wiring and accessible low – voltage – 42.4v peak or less – metal parts, including terminals.

44.2 The production-line test shall be in accordance with either condition A or condition B of table 44.1.

**Table 44.1**  
**Production – line test conditions**

| Appliance rating | Condition A          |         | Condition B            |         |
|------------------|----------------------|---------|------------------------|---------|
|                  | Potential, V         | Time, s | Potential, V           | Time, s |
| 250V or less     | 1000                 | 60      | 1200                   | 1       |
| 251- 600V        | 1000+2V <sup>a</sup> | 60      | 1200+2.4V <sup>a</sup> | 1       |

<sup>a</sup> rated voltage of the appliance.

44.3 The flatiron may be in a heated or unheated condition for the test.

44.4 The test is to be conducted when the flatiron is completely assembled. It is not intended that the flatiron be unwired, modified, or disassembled for the test.

*Exception no. 1: Parts such as snap covers or friction-fit knobs that would interfere with performing the test need not be in place.*

*Exception no. 2: The test may be performed before final assembly if the test represents that for the completely flatiron.*

44.5 The test equipment shall include a transformer having an essentially sinusoidal adequate output, a means of indicating the test potential, an audible or visual indicator of electrical breakdown, and either a manually reset device to restore the equipment after electrical breakdown or an automatic reject feature of any unacceptable unit.

44.6 If the output of the test equipment transformer is less than 500 VA, the equipment shall include a voltmeter in the output circuit to directly indicate the test potential.

44.7 If the transformer output is 500VA or larger, the test potential may be indicated:

- a) By a voltmeter in the primary circuit or in a tertiary – winding circuit,
- b) By a selector switch marked to indicated the test potential, or
- c) By a marking in a readily visible location to indicate the test potential of equipment having a single test potential output. If marking is used without an indicating voltmeter, the equipment shall include a positive means, such as an indicator lamp, to indicate that the manually reset switch has been reset following a dielectric breakdown.

44.8 Test equipment other than those described in 44.5 – 44.7 may be used if found to accomplish the intended factory control.

44.9 During the test, the primary switch is to be in the on position, both sides of the primary circuit of the flatiron are to be connected together and to one terminal of the test equipment, and the second test –equipment terminal is to be connected to accessible dead metal.

*Exception: A flatiron- resistive, high- impedance winding, and the like – having circuitry not subject to excessive secondary- voltage build- up in case of electrical breakdown during the test may be tested with a single –pole primary switch, if used, in the off position, or with only one side of the primary circuit connected to the test equipment when the primary switch is in the on position, or when a primary switch is not used.*

## **45 Grounding Continuity Test**

45.1 Each flatiron that has a power-supply cord with a grounding conductor shall be tested, as a routine production-line test, to determine that there is grounding continuity between the grounding blade of the attachment plug and accessible dead-metal of the flatiron that is likely to become energized.

45.2 Only a single test need be conducted if the accessible metal selected is conductively connected by design to all other accessible metal.

45.3 Any indicating device, such as an ohmmeter, a battery-and buzzer combination, or the like, may be used to determine compliance with the grounding continuity requirement in 45.1.

## RATING

### 46 General

46.1 A flatiron shall be rated in amperes or watts and also in volts; and may be rated for alternating current only. The voltage rating shall be in accordance with any appropriate single voltage or range of voltage.

46.2 The rating shall include the number of phases if the flatiron is designed for use on a polyphase circuit, and shall include the frequency if necessary because of solenoid coils, relay coils, or the like.

## MARKING

### 47 General

47.1 A flatiron shall be permanently marked where it will be visible – after installation in the case of a permanently connected flatiron – with:

- a) The name or trademark of the manufacturer,
- b) The catalog number or the equivalent,
- c) The electrical rating, and
- d) The date or other dating period of manufacture not exceeding any three consecutive months.

*Exception: The date of manufacture may be abbreviated; or may be in a nationally accepted conventional code or in a code affirmed by the manufacturer, provided that the code:*

- a) Does not repeat in less than 10 years for a household product and less than 20 years for a commercial product, and*
- b) Does not require reference to the production records of the manufacturer to determine when the product was manufactured.*

The frequency, if marked, shall be expressed in one of the following, terms: hertz, Hz, cycles-per-second, cps, cycles/second, or c/s.

47.2 Each individual replaceable heating element or heating unit of a flatiron shall be plainly and permanently marked with its electrical rating in amperes or watts and volts or with the manufacture's part number.

47.3 A flatiron of modular design intended to permit replacement of parts by the user shall be plainly marked with a warning that such service should be done only while the flatiron is disconnected from the supply circuit.

47.4 A marking intended to caution the operator shall be legible and visible by the operator during normal operation of the flatiron.

47.5 A cautionary marking shall be prefixed by the word “CAUTION”, “WARNING”, or “DANGER” in letters not less than 1/8 in (3.2mm) high. The remaining letters of such marking shall not be less than 1/16 in (1.6mm) high.

47.6 A cautionary marking that is required to be permanent shall be located on a part:

- a) That would require tools for removal, or
- b) That cannot be removed without impairing the operation of the flatiron.

47.7 A marking that is required to be permanent shall be molded, die-stamped, paint-stenciled, stamped or etched metal that is permanently secured, or indelibly stamped lettering on a pressure sensitive label secured by adhesive that, upon investigation, is found to be acceptable for the application. Ordinary usage, handling, storage, and the like of a flatiron is considered in the determination of the permanence of a marking. See permanence of marking, section 42.

47.8 If, during the normal temperature test, a wire within a terminal box or compartment intended for branch-circuit supply connections attains a temperature higher than 60°C (140°F), the flatiron shall be permanently marked “for supply connections, use wire suitable for at least...C (...F)” or with an equivalent statement. The temperature to be used in the marking shall be as specified in the second column of table 47.1.

**Table 47.1**  
**Temperature for marking**

| Temperature attained in terminal box or compartment |              | Temperature in marking |        |
|---|--------------|------------------------|--------|
| 61- 75°C  | (142-167°F)  | 75C                    | (167F) |
| 76- 90°C  | (169- 194°F) | 90C                    | (194F) |

47.9 A commercial flatiron employing an indicator as specified in 17.2.2 shall be marked, where visible to the user, with the word “WARNING” and the following or equivalent: “if indicator is on, flatiron is malfunctioning- disconnect from power supply and have flatiron serviced by qualified service personnel.”

47.10 A commercial flatiron shall be marked “not for household use”, unless it is obviously intended for commercial use. A separate steam supply or permanent connection to the branch circuit are among those features considered as obvious for commercial use.

47.11 For dual voltage appliances, the input voltage selector shall be marked to indicate each voltage position.

## 48 Instruction Manual

48.1 An instruction manual or the equivalent shall be provided with each household flatiron. The manual shall specifically warn the user of each potential risk and state the precautions that should be taken to guard against such risk. The safety instruction specified in 48.3 shall be a permanent part of the manual but separated in format from the other instructions, and shall appear before the operating instructions in the manual. The upper case letters in the text and illustrations in the safety instructions shall not be less than 5/64 in (2.0mm) high. Lower case letters shall not be less than 1/16 in (1.6mm). "IMPORTANT SAFETY INSTRUCTIONS" and "SPECIAL INSTRUCTIONS" shall be in letters not less than 3/16 in (4.8 mm) high.

*Exception: The special instructions may be separated from the important safeguards and located elsewhere in the instruction manual provided that SAVE THESE INSTRUCTIONS follow the last item in the list of important safeguards.*

48.2 For a dual voltage flatiron, instructions shall be provided:

- a) For changing the voltage selector switch if provided,
- b) For providing the correct supply connection means for each voltage setting, and
- c) The following wording or the equivalent "For use in the U. S.A., the voltage selector switch should be placed in the 120-volt position. For use in several countries overseas, the voltage selector switch may need to be placed in the 240-volt position. Confirm the voltage available at each overseas location before using the flatiron. For connection to a 240-volt supply, use a suitable attachment plug adapter of the proper configuration for the power supply receptacle."

48.3 Unless specific conflict of the application to a product exists, the text of the instructions shall be as shown below or the equivalent. The items may be numbered and "READ ALL INSTRUCTIONS BEFORE USING" and "SAVE THESE INSTRUCTIONS" shall be first and last respectively in the list if items. Item 9 shall be required only for a commercial flatiron provided with an indicator as mentioned in 17.2.2. Other important and appropriate safety instruction items considered appropriate by the manufacturer may be included.

### IMPORTANT SAFETY INSTRUCTIONS

When using your flatiron, basic safety precautions should always be followed, including the following:

#### READ ALL INSTRUCTIONS BEFORE USING

1. Use iron only for its intended use.
2. To protect against a risk of electric shock, do not immerse the iron in water or other liquids.
3. The iron should always be turned to "off" before plugging or unplugging from outlet. Never yank cord to disconnect from outlet; instead, grasp plug and pull to disconnect.
4. Do not allow cord to touch hot surfaces. Let iron cool completely before putting away. Loop cord loosely around iron when storing.

5. Always disconnect iron from electrical outlet when filling with water or emptying and when not in use.
6. Do not operate iron with a damaged cord or if the iron has dropped or damaged. To avoid the risk of electric shock, do not disassemble the iron; take it to a qualified serviceman for examination and repair. Incorrect reassembly can cause a risk of electric shock when the iron is used.
7. Close supervision is necessary for any appliance being used by or near children. Do not leave iron unattended while connected or on an ironing board.
8. Burns can occur from touching hot metal parts, hot water, or steam. Use caution when you turn a steam iron upside down- there may be hot water in the reservoir.
9. If the malfunction indicator goes on, the flatiron is not operation normally. Disconnect from the power supply and have the flatiron serviced by qualified service personnel.

### **SPECIFIAL INSTRUCTIONS**

1. To avoid a circuit overload, do not operate another high wattage appliance on the same circuit.
2. If an extension cord is absolutely necessary, a 10-ampere cord should be used. Cord rated for less amperage may overheat. Care should be taken to arrange the cord so that it cannot be pulled or tripped over.

### **SAVE THESE INSTRUCTIONS**

48.4 For a dual voltage appliance, the following instructions shall be included with the instructions required by 48.3.

11. "Be sure dual voltage selector is in correct voltage position before operating. Before plugging in, read the information about dual voltage operation contained in the instruction section of this manual.

*Exception: The instructions for a dual voltage appliance that is not provided with a dual voltage selector need only include." Before plugging in, read the information about dual voltage operation contained in the instruction section of this manual."*

12. "This appliance was set at the factory to operate at \_\_\_\_volts. Refer to operating instructions section of this manual for conversion to\_\_ volt operation" or the equivalent. The blanks are to be filled in with the appropriate information.

*Exception: This instruction does not apply if an appliance operates over a range of voltage and requires no adjustment by the user, such as an appliance that employs a positive temperature coefficient (PTC) heating element intended for use over a range of voltages that requires no adjustment by the user.*



## APPENDIX A

### Standards for Components

Standards under which components of the products covered by this standard are evaluated include the following:

Title of standard –UL standard designation

---

Attachment Plugs and Receptacles – UL 498

Cord Reel – UL 355

Cord Sets and Power-Supply Cords – UL 817

Insulation Coordination Including Clearances and Creepage Distances for Electrical Equipment – UL 840

Plastic Materials for Parts in Devices and Appliances, Test for Flammability of – UL 94

Polymeric Materials-Use in Electrical Equipment – UL746C

Temperature-Indicating and-Regulating Equipment – UL 873

Thermal Cutoffs for Use in Electrical Appliances and Components – UL1020

Sheathed heating elements – UL 1030

Special-Use Switches – UL 1054

Wire, Flexible Cord and Fixture – UL62

Wire Connectors – UL 486A-486B



No text on this page



## **CANDAIN REQUIREMENTS COMPARISON GUIDE CRG 1005**

---

### **UL AND CANDIAN STANDARDS FOR ELECTRIC FLATIRONS**

Product category: flatirons and garment- finishing appliances

UL Category Control Number: IKOZ7

UL standard:

Standard for Electric Flatirons  
UL 1005  
Fourth Edition

Canadian Standard:

Electric Irons  
CAN/CSA –C22.2 NO. 81-M90  
Third Edition

This Canadian Requirement Comparison Guide is only intended to identify Canadian requirements that must be applied in addition to the requirements in the UL standard to obtain a C-UL mark. The guide is not intended to replace a thorough review and comparison of the requirements applicable to the product category as contained in the applicable UL and Canadian Standards. Where requirements are not specifically addressed, compliance with the requirements in the UL Standard satisfy the requirements in the Canadian Standard.

The actual requirements applied for a C-UL product investigation may differ from those identified in this guide based on the specific feature, characteristics, components, materials, or systems used in the product.

CRG: 1005

Issue N.: 2

Issue Date: July, 10, 1998

Revisions of this guide will be made by issuing revised or additional pages bearing their date of issue. A Canadian Requirement Comparison Guide is current only if it incorporates the most recently adopted revisions, all of which are itemized on the transmittal notice that accompanies the latest set of revision pages for the Guide.

The following outlines the requirements contained in CSA C22.2 No.81-M90 that are in addition to the requirements in UL 1005 that must be met in order for a product to bear the appropriate UL marking. UL provides a certification program for products that meet the Canadian requirements. The C-UL mark is the manufactures assurance that products as evaluated by UL, continue to comply with the appropriate Canadian requirements.

**Copyright © 2002 underwriters laboratories inc.**

| <b><u>Requirements Topics</u></b>                                      | <b><u>CSA Clauses</u></b> | <b><u>Comparison</u></b>   |
|--|---------------------------|--|
| Construction-General   | 4.1.3                     | The maximum input for flatirons intended to be connected to a 15A, 120V branch circuit shall not exceed 1500W.   |
| Nonmetallic Enclosures   | 4.2.5.1                   | Heating element enclosures shall have a minimum v-0 flame rating.  |
|  | 4.2.5.3                   | Nonmetallic materials shall have a suitable temperature rating not less than the normal operating temperature of the product unless evaluated to clause 6.14.1   |
| Enclosure Openings   | 4.2.6.1                   | Openings below terminals, heater elements, wiring, and other live parts shall not be provided unless baffled   |
| Cord-Connected Irons – Power Supply Cord, Cord Sets, and Terminal Pins | 4.6.2.3                   | Attachment plugs shall comply with CSA C22.2No.42.   |
| Current- Carrying Parts  | 4.8.2                     | Copper wire and parts shall not operate at temperatures higher than 180°C<br>Tinned or plated copper may be acceptable to 218°C  |
| Switches and Controls (Except Overheat Protectors)                     | 4.10.1                    | Switches and controls shall comply with CSA C22.2 No.24, C22.2No.55, and C22.2No.111.  |
| Electromagnetic Interference Filters                                   | 4.12.1, 4.12.2            | Filters shall comply with CSA C22.2 No. 8. Filters shall not to be connected between live parts and exposed conductive parts.  |
| Marking  | 5.2                       | The month and year of manufacture or date code shall be marked on the product.   |
| Tests- Rating  | 6.2                       | A maximum input tolerance of +5%, -10% is specified.   |
| Test Voltage   | 6.3.2                     | The test voltage shall be adjusted to compensate for equipment   |
| Soleplate Temperature (Automatic Irons)                                | 6.4.3                     | The thermocouple shall be held in place with fiberglass tape.  |
| Physical Abuse – Drop Test (Automatic Irons)                           | 6.5.1 6.5.2               | The drop test for a steam iron shall be conducted with the water reservoir filled. The maximum allowable soleplate temperature downward drift is +10°C. If a temperature downward drift of more than -10°C is encountered, a new sample is subjected to the remaining tests. |
| Thermostat Endurance (Automatic Irons)                                 | 6.6                       | Thermostat calibration shall not exceed a maximum change of +10°C or -20°C of the as received condition.   |
| Dielectric Strength (Steam Irons)                                      | 6.7                       | The test shall be conducted after 24 h filled with water.  |
| Temperature (Abnormal)   | 6.8.4.1 6.8.4.2           | The temperature (Abnormal) test is to be done with the sample supported on three, pointed 6 mm diameter metal rods<br>Blisters are permitted, but shall not exceed 1.6mm high.   |

Table continued on next page





**Table continued**

| <b><u>Requirements Topics</u></b> | <b><u>CSA Clauses</u></b> | <b><u>Comparison</u></b>  |
|-----------------------------------|---------------------------|---|
| Leakage Current                   | 6.13.10                   | The overfill test shall be conducted with a hard water solution, 450mL maximum. The solution shall be poured into sample in the normal position until overflow. Leakage current shall be measured with sample in the normal vertical and horizontal full positions. |
| Insulating Liner Investigation    | 6.15                      | Additional investigation shall be performed on an insulating liner including humidity, bend, and dielectric strength test as well as a thermal aging test.  |



**Superseded requirements for  
The standard for  
Electric flatirons**

**UL 1005, fourth edition**

The requirements shown are the current requirements that have been superseded by requirement in revisions issued for this standard. To retain the current requirements, do not discard the following requirements until the future effective dates are reached.

27.1.1 The drop tests described in 27.1.2 and 27.1.7 shall not:

- a) Cause an opening in the enclosure of a flatiron that will permit a probe having the dimensions shown in figure 7.2 to contact an uninsulated live part when inserted point-first into the opening;
- b) Damage a flatiron to the extent that it will not comply with the requirements in 26.1 and 26.2;  
or
- c) Cause an opening in the enclosure of a flatiron located within 1 in (25.4mm) of the soleplate surface that will permit a probe having the dimensions shown in figure 7.1 to contact an uninsulated live part when inserted point-first into the opening.

27.1.3 The drops test described in 27.1.2 and 27.1.7 are to be conducted without water in the reservoir of a steam flatiron. The sling or drop platform mentioned in 27.1.7 may be used for the tests.



No Text o This Page