

ASME B107.30-2002

CROSS TIP SCREWDRIVERS

AN AMERICAN NATIONAL STANDARD



The American Society of
Mechanical Engineers

CROSS TIP SCREWDRIVERS

1 SCOPE

This Standard covers straight handle-type screwdrivers of PHILLIPS^{®1} and POZIDRIV^{®1} design intended for manual operation in driving or removing screws with PHILLIPS^{®1} or POZIDRIV^{®1} recesses. The screwdrivers are of the types normally used by cabinetmakers, carpenters, sheet metal workers, production workers, mechanics, etc. The intention is to specify performance rather than design detail.

Inclusion of dimensional data in this Standard is not intended to imply that all of the products described herein are stock production sizes. Consumers are requested to consult with manufacturers concerning lists of stock production sizes.

Using a screwdriver as a pry bar or striking it with a hammer are clearly misuses of the tool, and nothing in this Standard shall be interpreted as condoning any tool misuse. Further information about proper use of screwdrivers is contained in the Guide to Hand Tools - Selection, Safety Tips, Proper Use and Care.

2 CLASSIFICATION

Cross tip screwdrivers covered by this Standard are of the following types and designs:

Type I Phillips (PH)

Class 1: plain

Class 2: bolster

Class 3: stubby

Class 4: pocket

Type II Pozidriv (PZ)

Class 1: plain

Class 2: bolster

Class 3: stubby

Class 4: pocket

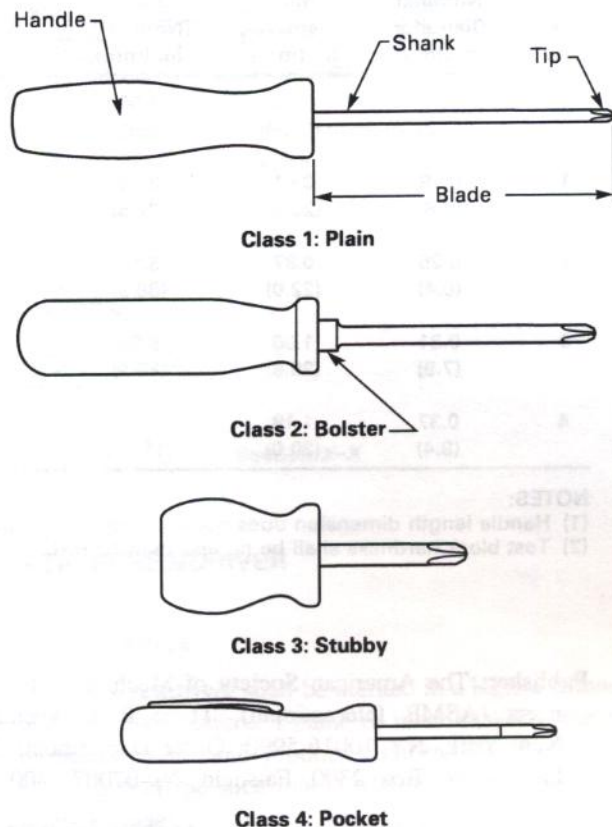

FIG. 1 TYPE I (PH) AND TYPE II (PZ) SCREWDRIVER ASSEMBLIES

3 NORMATIVE REFERENCES

The following documents form a part of this Standard to the extent specified herein. At the time of publication, the editions indicated were valid. All standards are subject to revision and parties to agreements based on this American National Standard are encouraged to investigate the possibility of applying the most recent editions of the documents indicated below.

ASME B107.31M-1997, Screwdrivers, Cross Tip Gaging

¹ PHILLIPS[®] and POZIDRIV[®] PZ1[®], PZ2[®], and PZ3[®] are registered trademarks of the Phillips Screw Company.

TABLE 1A DIMENSIONAL AND PERFORMANCE CHARACTERISTICS OF TYPE I (PH) SCREWDRIVERS

Blade		Handle		Performance			
				Test Block [Note (2)]		Torsional Test	
				A	B		
Point Size	Nominal Diameter, in. (mm)	Min. Diameter, in. (mm)	Min. Length [Note (1)], in. (mm)	Major Wing Spread [See Fig. (5)] +0.002/-0.002 in. (+0.05/-0.05 mm)	Minor Wing Spread [See Fig. (5)] +0.002/-0.002 in. (+0.05/-0.05 mm)	Min. Assembly, in.-lbf (N·m)	Min. Tip, in.-lbf (N·m)
0	0.12 (3.0)	0.50 (12.7)	1.50 (38.1)	0.090 (2.30)	0.032 (0.80)	6 (0.68)	8.9 (1.01)
1	0.19 (4.8)	0.81 (20.6)	3.25 (82.5)	0.142 (3.60)	0.050 (1.30)	25 (2.82)	31 (3.50)
2	0.25 (6.4)	0.87 (22.0)	3.50 (88.9)	0.233 (5.90)	0.090 (2.30)	60 (6.88)	100 (11.30)
3	0.31 (7.9)	1.06 (26.9)	3.50 (88.9)	0.386 (9.80)	0.150 (3.80)	150 (16.95)	220 (24.86)
4	0.37 (9.4)	1.18 (30.0)	4.37 (111.0)	0.486 (12.30)	0.200 (5.10)	200 (22.60)	340 (34.41)

NOTES:

(1) Handle length dimension does not apply to the stubby or pocket screwdrivers.

(2) Test block hardness shall be no less than 60 HRC.

Publisher: The American Society of Mechanical Engineers (ASME International), Three Park Avenue, New York, NY 10016-5990; Order Department: 22 Law Drive, Box 2300, Fairfield, NJ 07007-2300

ASTM D 2240-97, Standard Test Method for Rubber Property — Durometer Hardness

ASTM E 18-00, Standard Test Methods for Rockwell Hardness and Rockwell Superficial Hardness of Metallic Materials

Publisher: American Society for Testing and Materials (ASTM), 100 Barr Harbor Drive, West Conshohocken, PA 19428-2959

SAE J1703-JAN95, Motor Vehicle Brake Fluid

Publisher: Society of Automotive Engineers (SAE), 400 Commonwealth Drive, Warrendale, PA 15096

Guide to Hand Tools - Selection, Safety Tips, Proper Use and Care

Publisher: Hand Tools Institute (HTI), 25 North Broadway, Tarrytown, NY 10591

4 DEFINITIONS (SEE FIG. 1)

assembly: the blade plus the handle.

blade: the shank plus the tip.

bolster: an increase in the cross sectional area of the shank at the junction of the handle.

handle: that portion of the screwdriver that is gripped with the hand.

shank: the portion of the blade between the tip and the handle.

tip: the portion of the blade that engages the screw recess.

5 REQUIREMENTS

5.1 General Requirements

The illustrations herein are descriptive, not restrictive, and shall not preclude designs otherwise in accordance with the requirements of this Standard.

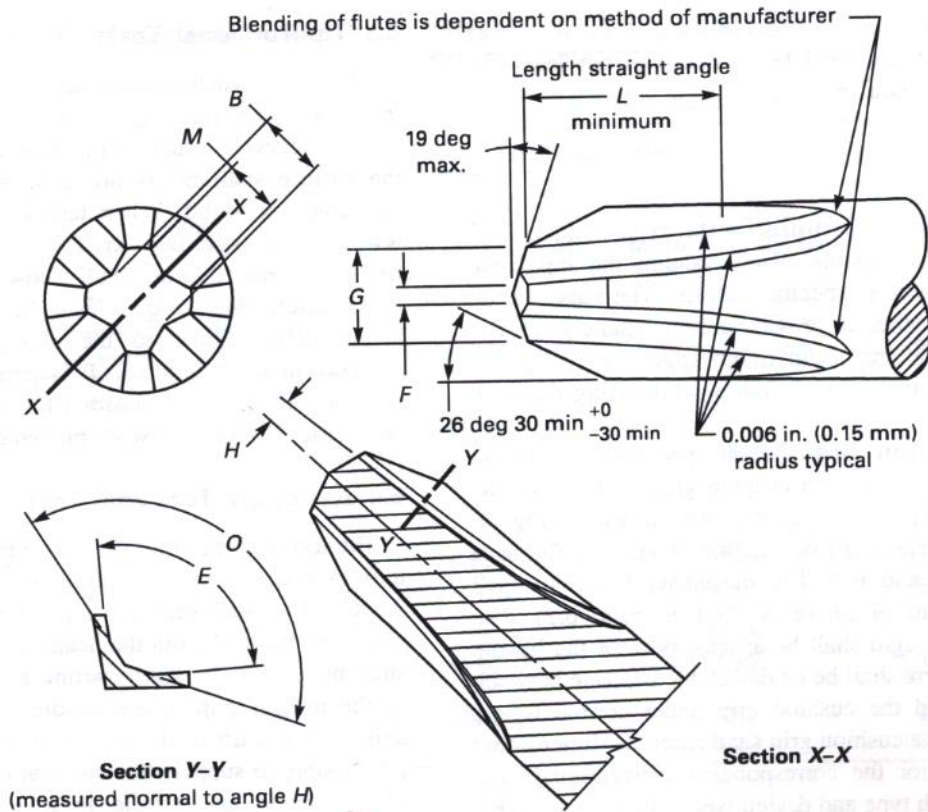

FIG. 2 TYPE I (PH) CROSS TIP SCREWDRIVER

5.1.1 Type I (PH). These screwdrivers are for driving or removing screws with Phillips® recesses. Figure 1 illustrates typical appearances for Class 1 plain, Class 2 bolster, Class 3 stubby, and Class 4 pocket with the optional pocket clip. The screwdrivers shall conform to the dimensional and performance characteristics specified in Tables 1A, 2, and 3 and Fig. 2. Tip dimensions shall be gaged in accordance with ASME B107.31M.

5.1.2 Type II (PZ). These screwdrivers are for driving or removing screws with Pozidriv® recesses. Figure 1 illustrates typical appearances for Class 1 plain, Class 2 bolster, Class 3 stubby, and Class 4 pocket with the pocket clip optional. The screwdrivers shall conform to the dimensional and performance characteristics specified in Tables 1B, 2, and 4 and Fig. 3. Tip dimensions shall be gaged in accordance with ASME B107.31M.

5.2 Materials

The materials used in the manufacture of a screwdriver shall be such as to produce products conforming to the performance requirements specified herein.

5.3 Markings

Each screwdriver shall be marked in a legible manner with the manufacturer's name or identification, country of manufacture, and product number. The method of marking shall be such that it will remain legible under normal usage of a screwdriver over an extended period of time.

5.4 Blade

5.4.1 General Requirements. Blades made of steel shall be properly heat treated to meet the performance specified herein. The blade shall be held securely in the handle. The blade shall be essentially free from scale, seams, laps, and cracks, which may adversely affect durability or serviceability of the tool.

5.4.2 Finish. The blade shall be treated in a manner to resist rust or corrosion. There shall be no evidence of peeling or chipping of any coating where applicable.

5.4.3 Hardness. The tip portion of the screwdriver or the entire blade shall be hardened to not less than 48 HRC (see para. 6.2).

5.5 Handle

5.5.1 General Requirements. The handle shall be of a material capable of withstanding the applicable test requirements as specified herein. The handle shall be suitably finished to provide a comfortable grip. The handle shall be free from rough edges, sharp corners or tool marks that affect comfort while using the tool.

5.5.2 Cushion Grip. When specified, the handle shall be furnished with a cushion grip, and the screwdriver shall typically resemble that shown in Fig. 4. The grip material shall be capable of meeting the tests of paras. 6.6 and 6.7. The durometer hardness shall be a maximum of Shore A 75 (see para. 6.2). The cushion grip length shall be at least 60% of the handle length, and there shall be no detectable slippage between the handle and the cushion grip under normal usage. A handle with a cushion grip shall meet the dimensional requirements for the corresponding conventional type handle for each type and design (see Tables 1A and 1B).

5.6 Workmanship

The screwdriver shall be free from conditions which may impair its serviceability, durability or comfort.

6 TEST PROCEDURES

Many tests required herein are inherently hazardous, and adequate safeguards for personnel and property shall be employed in conducting such tests. The following tests are intended to ensure conformance with the performance requirements of this Standard.

6.1 Visual Examination

Conformance with marking and other requirements not established by test shall be verified by visual examination.

6.2 Hardness Tests

The Rockwell hardness test shall be conducted in accordance with ASTM E 18. The Shore durometer test shall be conducted in accordance with ASTM D 2240.

6.3 Tip Torsional Test

The tip of each sample under test shall be placed in a test block (see Fig. 5) having the corresponding size of recess of such depth that the wing spread at the surface shall be as noted in performance section of Table 1A or 1B. When tested to the minimum tip torque value specified in Table 1A or 1B, neither the shank nor the tip shall show visible permanent deformation. The torque shall be applied by forces acting perpendicular to the axis with the tip held securely in the test block. It is permissible to support the blade in a suitable position for test. The blade shall be restricted from endwise movement during testing.

6.4 Assembly Torsional Test

The test shall be conducted after preheating the entire tool to a uniform temperature of $125 \pm 5^\circ\text{F}$ ($51.7 \pm 2.8^\circ\text{C}$). The load shall be applied within 1 min after removing the tool from the heating medium. The torque shall be applied by forces acting at or near the middle of the natural grip of the handle perpendicular to the axis with the tip held securely in the test block. It is permissible to support the shank at or near the junction of the shank and handle in a suitable position for test. The screwdriver shall be restricted from endwise movement during testing. When tested to the minimum assembly torque value specified in Table 1A or 1B, the assembly shall not show a permanent slippage between the blade and handle.

6.5 Tip Toughness Test

The tip shall be torsionally tested as described in para. 6.3 except that the torque shall be increased until failure. If a fracture occurs, the pieces shall be refitted and the tip shall show that permanent deformation had occurred prior to fracture. If the tip fails without exhibiting such deformation, it shall be considered to have failed the tip toughness test.

6.6 Solvent Resistance Test

Screwdrivers shall be capable of undergoing the following test without damage. Handles are to be fully immersed in motor vehicle brake fluid (SAE J1703), gasoline, ethylene glycol, and ethyl alcohol for 15 min at room temperature, removed, and allowed to stand for 24 hr. A new assembly shall be used for each of the four test liquids. There shall be no permanent swelling, surface attack (except for manufacturer's identification or paint removal), or failure to comply with paras. 6.4 and 6.7. After testing, the hardness of the

TABLE 1B DIMENSIONAL AND PERFORMANCE CHARACTERISTICS OF TYPE II (PZ) SCREWDRIVERS

Point Size	Blade Nominal Diameter, in. (mm)	Test Block Performance					
		Handle		Test Block [Note (2)]		Torsional Test	
		Min. Diameter, in. (mm)	Min. Length [Note (1)], in. (mm)	A	B	Min. Assembly, in.-lbf (N·m)	Min. Tip, in.-lbf (N·m)
				Major Wing Spread [See Fig. (5)] +0.002/-0.002 in. (+0.05/-0.05 mm)	Minor Wing Spread [See Fig. (5)] +0.002/-0.002 in. (+0.05/-0.05 mm)		
0	0.12 (3.0)	0.50 (12.7)	1.50 (38.1)	0.090 (2.30)	0.0355 (0.90)	6 (0.68)	8.9 (1.01)
1	0.19 (4.8)	0.81 (20.6)	3.25 (82.5)	0.142 (3.60)	0.0545 (1.40)	25 (2.82)	35 (3.95)
2	0.25 (6.4)	0.87 (22.0)	3.50 (88.9)	0.233 (5.90)	0.095 (2.40)	60 (6.88)	100 (11.30)
3	0.31 (7.9)	1.06 (26.9)	3.50 (88.9)	0.386 (9.80)	0.155 (3.90)	150 (16.95)	350 (39.54)
4	0.37 (9.4)	1.18 (30.0)	4.37 (111.0)	0.486 (12.30)	0.203 (5.20)	200 (22.60)	550 (62.14)

NOTES:

- (1) Handle length dimension does not apply to the stubby or pocket screwdrivers.
(2) Test block hardness shall be no less than 60 HRC.

TABLE 2 IMPACT TEST DATA

Blade Diameter (Nominal Stock Size), in. (mm)		Height of Drop of 15 lb (6.8 kg) Weight for Impact Tests at Room Temperature, in. (mm)		Max. Blade Penetration, in. (mm)		Impact Energy, ft-lb (N·m)	
0.12	(3.0)	1.5	(38)	0.75	(19.0)	1.9	(2.5)
0.16	(4.0)	4.0	(102)	0.75	(19.0)	5.0	(6.8)
0.19	(4.8)	6.0	(152)	0.75	(19.0)	7.5	(10.2)
0.22	(5.6)	8.0	(203)	0.62	(15.7)	10.0	(13.6)
0.25	(6.4)	10.0	(254)	0.62	(15.7)	12.5	(17.0)
0.28	(7.1)	12.0	(305)	0.62	(15.7)	15.0	(20.3)
0.31	(7.9)	15.0	(381)	0.62	(15.7)	18.8	(25.4)
0.34	(8.6)	17.0	(432)	0.62	(15.7)	21.3	(28.8)
0.37 and over	(9.4 and over)	20.0	(508)	0.62	(15.7)	25.0	(33.9)

cushion grip, if furnished, shall not be greater than durometer Shore A 80.

6.7 Handle Impact Test

This test shall be performed at room temperature. The blade of the screwdriver shall be mounted vertically

in a fixture affixed to the base of a suitable falling weight impact device. The blade shall rest on a solid surface to ensure that the blade does not move vertically in the fixture. The weight shall be 15 lb (6.8 kg) and shall be dropped unrestricted with some means to ensure that the full force of the falling weight will be acting

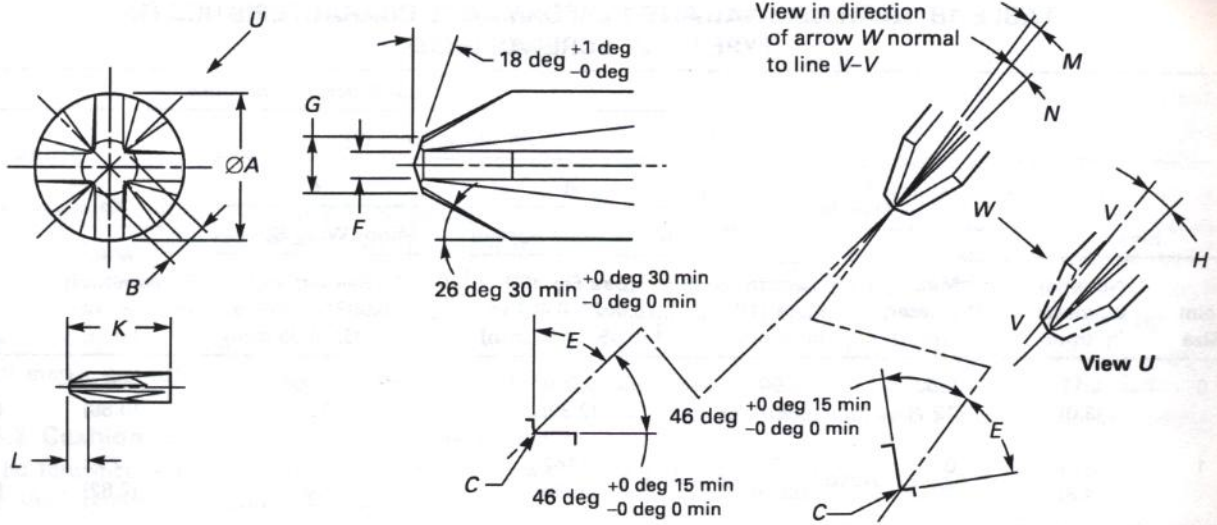

FIG. 3 TYPE II (PZ) CROSS TIP SCREWDRIVER

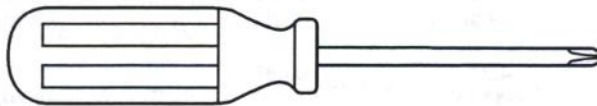

FIG. 4 TYPICAL APPEARANCE OF A CUSHION GRIP SCREWDRIVER

TABLE 3 TYPE I (PH) TIP DIMENSIONS (SEE FIG. 2)

Point Size	B, in. (mm) ± 0.001 in. (± 0.025 mm)	O, deg +30 min, -0	G, in. (mm) ± 0.001 in. (± 0.025 mm)	H, deg +0, -30 min,	F [Note (2)], in. (mm)		E, deg +30 min, -0	M, in. (mm) ± 0.001 in. (± 0.025 mm)	L Min., in. (mm)
					Max.	Min.			
0	0.023 (0.584)	Note (1)	0.032 (0.813)	7	0.012 (0.305)	0.010 (0.254)	92	0.0151-0.0114 (0.384-0.290)	0.12 (3.0)
1	0.0394 (1.001)	138	0.050 (1.270)	7	0.020 (0.508)	0.016 (0.406)	92	0.0202 (0.513)	0.12 (3.0)
2	0.0606 (1.539)	140	0.090 (2.286)	5 deg 45 min	0.028 (0.711)	0.023 (0.584)	92	0.0434 (1.102)	0.19 (4.8)
3	0.0983 (2.497)	146	0.150 (3.810)	5 deg 45 min	0.033 (0.838)	0.027 (0.686)	92	0.0826 (2.098)	0.28 (7.1)
4	0.1407 (3.574)	153	0.200 (5.080)	7	0.045 (1.143)	0.040 (1.016)	92	0.1078 (2.738)	0.34 (8.6)

NOTES:

- (1) For point size 0, dimension is a radius rather than an angle. O = 0.0109 in. (0.277 mm) maximum to 0.0082 in. (0.208 mm) minimum radius
- (2) Resultant dimension.

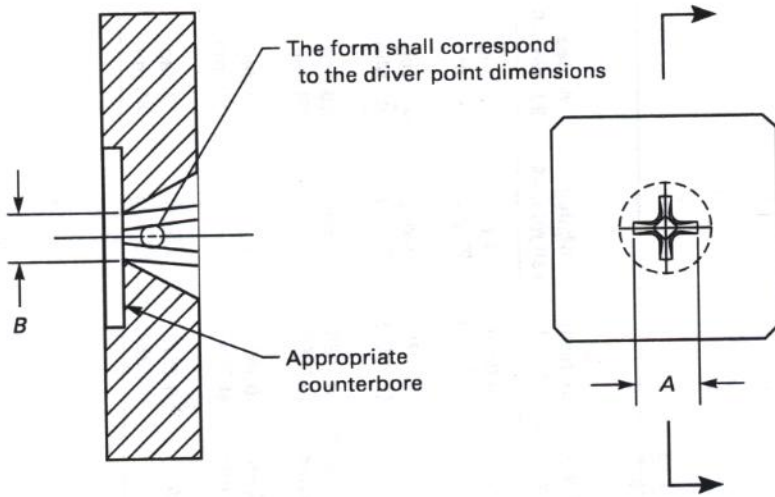

FIG. 5 TEST BLOCK WING SPREAD

normal to the striking surface. In conducting this test, care shall be taken that the impact energy will not be expended in flexing of the blade or in driving the screwdriver tip into the surface on which it rests. The blade may be shortened or blunted, if necessary, to ensure a proper test. An equivalent test may be used if the required ft-lb (N·m) is satisfied.

The blade shall not penetrate into the handle more than specified in Table 2 when the weight has been dropped ten times from the applicable height shown in Table 2. The first drop ensures that the blade is seated in the handle. The difference in length after the first and after the tenth drop is the blade penetration.

The screwdriver handle shall neither break, crack, nor significantly distort as a result of the above test.

“Significantly distort” (for the purpose of this test) means an increase of at least 5% in the handle diameter, either as a uniform or irregular bulge.

7 DESIGNATIONS

Screwdrivers shall be designated by the following data in the sequence shown:

- type
- class
- tip size
- exposed blade length
- options as applicable

TABLE 4 TYPE II (PZ) TIP DIMENSIONS (SEE FIG. 3)

Point Size	A, in. (mm) ± 0.010 (± 0.254)	B, in. (mm)		C (rad), in. (mm)		E, deg +7 min, -0	F [Note (1)], in. (mm)		G, in. (mm)		H, deg +0, -30 min	L, in. (mm) (Min.)	M, deg +30 min, -0	N, deg +30 min, -0
	Max.	Min.	Max.	Min.	Max.		Min.	Max.	Min.					
0	0.125 (3.175)	0.280 (0.7112)	0.0265 (0.6731)	0.004 (0.102)	0.003 (0.076)	46	0.0175 (0.4445)	0.0165 (0.4191)	0.0360 (0.9144)	0.0350 (0.8890)	7	0.0829 (2.1057)	4 deg 23 min	7 deg 45 min
1	0.188 (4.775)	0.0438 (1.1125)	0.0423 (1.0744)	0.005 (0.127)	0.004 (0.102)	46	0.0275 (0.6985)	0.0265 (0.6731)	0.0550 (1.397)	0.0540 (1.3716)	7	0.1075 (2.7305)	4 deg 23 min	7 deg 45 Min.
2	0.250 (6.350)	0.0670 (1.7018)	0.0655 (1.6637)	0.012 (0.305)	0.006 (0.152)	46	0.0390 (0.9906)	0.0370 (0.9398)	0.0960 (2.4384)	0.0940 (2.3876)	5 deg 45 min	0.1538 (3.9065)	3 deg	6 deg 20 min
3	0.313 (7.950)	0.1020 (2.5908)	0.1005 (2.5527)	0.014 (0.356)	0.008 (0.203)	56 deg 15 min	0.0540 (1.3716)	0.0530 (1.3462)	0.1560 (3.9624)	0.1540 (3.9116)	5 deg 45 min	0.1852 (4.7041)	3 deg	6 deg 20 min
4	0.375 (9.525)	0.1520 (3.8608)	0.1505 (3.8227)	0.020 (0.508)	0.014 (0.356)	56 deg 15 min	0.0820 (2.0828)	0.0800 (2.032)	0.2040 (5.1816)	0.2020 (5.1308)	7	0.2573 (6.5354)	4 deg 23 min	7 deg 45 min

NOTE:

(1) Resultant dimension.

This Standard will be revised when the Society approves the issuance of a new edition. There will be no addenda issued to this edition.

ASME issues written replies to inquiries concerning interpretations of technical aspects of this Standard. Interpretations are published on the ASME Web site under the Committee Pages at <http://www.asme.org/codes/> as they are issued.

ASME is the registered trademark of The American Society of Mechanical Engineers.

This code or standard was developed under procedures accredited as meeting the criteria for American National Standards. The Standards Committee that approved the code or standard was balanced to assure that individuals from competent and concerned interests have had an opportunity to participate. The proposed code or standard was made available for public review and comment that provides an opportunity for additional public input from industry, academia, regulatory agencies, and the public-at-large.

ASME does not "approve," "rate," or "endorse" any item, construction, proprietary device, or activity.

ASME does not take any position with respect to the validity of any patent rights asserted in connection with any items mentioned in this document, and does not undertake to insure anyone utilizing a standard against liability for infringement of any applicable letters patent, nor assume any such liability. Users of a code or standard are expressly advised that determination of the validity of any such patent rights, and the risk of infringement of such rights, is entirely their own responsibility.

Participation by federal agency representative(s) or person(s) affiliated with industry is not to be interpreted as government or industry endorsement of this code or standard.

ASME accepts responsibility for only those interpretations of this document issued in accordance with the established ASME procedures and policies, which precludes the issuance of interpretations by individuals.

No part of this document may be reproduced in any form,
in an electronic retrieval system or otherwise,
without the prior written permission of the publisher.

The American Society of Mechanical Engineers
Three Park Avenue, New York, NY 10016-5990

CONTENTS

Foreword	iv
Standards Committee Roster	v
Correspondence With the B107 Committee	vi
1 Scope	1
2 Classification	1
3 Normative References	1
4 Definitions	2
5 Requirements	2
6 Test Procedures	4
7 Designations	7
Figures	
1 Type I (PH) and Type II (PZ) Screwdriver Assemblies	1
2 Type I (PH) Cross Tip Screwdriver	3
3 Type II (PZ) Cross Tip Screwdriver	6
4 Typical Appearance of a Cushion Grip Screwdriver	6
5 Test Block Wing Spread	7
Tables	
1A Dimensional and Performance Characteristics of Type I (PH) Screwdrivers	2
1B Dimensional and Performance Characteristics of Type II (PZ) Screwdrivers	5
2 Impact Test Data	5
3 Type I (PH) Tip Dimensions (See Fig. 2)	6
4 Type II (PZ) Tip Dimensions (See Fig. 3)	8

FOREWORD

The American National Standards Committee B107, Socket Wrenches and Drives, under sponsorship of The American Society of Mechanical Engineers, was reorganized as an ASME Standards Committee, and its title was changed to Hand Tools and Accessories. In 1996 its scope was expanded to address safety considerations.

The purposes of this Standard are to define general and dimensional data and safety considerations specifically applicable to cross tip screwdrivers and to specify test methods to evaluate performance relating to the defined requirements.

This new Standard includes a revision of material previously contained in ASME B107.15-1993 Flat Tip and Phillips Screwdrivers. Principal changes in this Standard are the inclusion of PZ type screwdrivers and safety considerations.

The format of this Standard is in accordance with *The ASME Codes and Standards Writing Guide 2000*. Requests for interpretations of the technical requirements of this Standard should be expressed in writing to the Secretary, B107 Committee, at the address below.

Suggestions for the improvement of this Standard are welcome. They should be addressed to The American Society of Mechanical Engineers, Secretary, B107 Standards Committee, Three Park Avenue, New York, NY 10016-5990.

The requirements of this Standard become effective at the time of publication. This Standard was approved as an American National Standard on May 13, 2002.

ASME Services

ASME is committed to developing and delivering technical information. At ASME's Information Central, we make every effort to answer your questions and expedite your orders. Our representatives are ready to assist you in the following areas:

ASME Press
Codes & Standards
Credit Card Orders
IMEchE Publications
Meetings & Conferences
Member Dues Status

Member Services & Benefits
Other ASME Programs
Payment Inquiries
Professional Development
Short Courses
Publications

Public Information
Self-Study Courses
Shipping Information
Subscriptions/Journals/Magazines
Symposia Volumes
Technical Papers

How can you reach us? It's easier than ever!

There are four options for making inquiries* or placing orders. Simply mail, phone, fax, or E-mail us and an Information Central representative will handle your request.

Mail
ASME
22 Law Drive, Box 2900
Fairfield, New Jersey
07007-2900

Call Toll Free
US & Canada: 800-THE-ASME
(800-843-2763)
Mexico: 95-800-THE-ASME
(95-800-843-2763)
Universal: 973-882-1167

Fax—24 hours
973-882-1717
973-882-5155

E-Mail—24 hours
Infocentral@asme.org

* Information Central staff are not permitted to answer inquiries about the technical content of this code or standard. Information as to whether or not technical inquiries are issued to this code or standard is shown on the copyright page. All technical inquiries must be submitted in writing to the staff secretary. Additional procedures for inquiries may be listed within.

AMERICAN NATIONAL STANDARDS FOR HAND TOOLS

Socket Wrenches, Hand (Inch Series)	B107.1-2002
Socket Wrenches, Extensions, Adaptors, and Universal Joints, Power Drive (Impact) (Inch Series)	B107.2-2002
Socket Wrenches, Power Drive (Non-Impact) (Inch Series)	B107.3-1978(R1991)
Driving and Spindle Ends for Portable Hand, Impact, Air, and Electric Tools (Percussion Tools Excluded)	B107.4M-1995
Socket Wrenches, Hand (Metric Series)	B107.5M-2002
Adjustable Wrenches	B107.8M-1996
Handles and Attachments for Hand Socket Wrenches — Inch and Metric Series	B107.10M-1996
Pliers: Diagonal Cutting and End Cutting	B107.11-2002
Nut Drivers (Spin Type, Screwdriver Grip) (Inch Series)	B107.12-1997
Pliers — Long Nose, Long Reach	B107.13M-1996
Hand Torque Tools	B107.14M-1994
Flat Tip Screwdrivers	B107.15-2002
Shears (Metal Cutting, Hand)	B107.16M-1998
Gages, Wrench Openings, Reference	B107.17M-1997
Pliers (Wire Twister)	B107.18M-1996
Pliers, Retaining Ring	B107.19-1993(R1998)
Pliers (Lineman's, Iron Worker's, Gas, Glass, Fence, and Battery)	B107.20M-1998
Wrench, Crowfoot Attachments	B107.21-1998
Electronic Cutters	B107.22M-1998
Pliers, Multiple Position, Adjustable	B107.23M-1997
Pliers — Performance Test Methods	B107.25M-1996
Pliers, Multiple Position (Electrical Connector)	B107.27-1996
Electronic Torque Instruments	B107.28M-1997
Electronic Tester, Hand Torque Tools	B107.29M-1998
Cross Tip Screwdrivers	B107.30-2002
Screwdrivers, Cross Tip Gaging	B107.31M-1997
Socket Wrenches for Spark Plugs	B107.34M-1997
Nut Drivers (Spin Type, Screwdriver Grip) (Metric Series)	B107.35M-1997
Electronic Pliers	B107.38M-1998
Nail Hammers — Safety Requirements	B107.41M-1997
Hatchets: Safety Requirements	B107.42M-1997
Wood-Splitting Wedges: Safety Requirements	B107.43M-1997
Glaziers' Chisels and Wood Chisels	B107.44-2002
Ripping Chisels and Flooring/Electricians' Chisels	B107.45-2002
Stud, Screw, and Pipe Extractors: Safety Requirements	B107.46M-1998
Metal Chisels: Safety Requirements	B107.47M-1998
Metal Punches and Drift Pins: Safety Requirements	B107.48M-1998
Nail Sets: Safety Requirements	B107.49M-1998
Brick Chisels and Brick Sets: Safety Requirements	B107.50M-1998
Star Drills: Safety Requirements	B107.51-2001
Nail-Puller Bars: Safety Requirements	B107.52M-1998
Ball Peen Hammers: Safety Requirements	B107.53M-1998
Heavy Striking Tools: Safety Requirements	B107.54-2001
Axes: Safety Requirements	B107.55M-2002
Body Repair Hammers and Dolly Blocks: Safety Requirements	B107.56-1999
Bricklayers' Hammers and Prospecting Picks: Safety Requirements	B107.57-2001
Riveting, Scaling, and Tinner's Setting Hammers: Safety Requirements	B107.58M-1998
Slugging and Striking Wrenches	B107.59-2002
Wrenches	B107.100-2002

The ASME Publications Catalog shows a complete list of all the Standards published by the Society. For a complimentary catalog, or the latest information about our publications, call 1-800-THE-ASME (1-800-843-2763).

ASME STANDARDS COMMITTEE B107

Hand Tools and Accessories

(The following is the roster of the Committee at the time of approval of this Standard.)

OFFICERS

R. R. McCullough, *Chair*

G. E. Olson, *Vice Chair*

J. R. Bird, *Secretary*

COMMITTEE PERSONNEL

J. R. Bird, The American Society of Mechanical Engineers

J. Davidson, Sears Roebuck and Co.

J. S. Foote, Trade Association Management, Inc.

A. Herskovitz, Consultant

H. Kimball, Naval Air Warfare Center

R. R. McCullough, Consultant

D. S. McKittrick, Western Forge

G. E. Olson, Gene Olson, Engineering Consultant, Ltd.

W. T. Pagac, Snap-on, Inc.

D. M. Eggert, *Alternate*, Snap-on, Inc.

J. M. Ster, General Services Administration

I. I. Harding, *Alternate*, General Services Administration

R. B. Wright, Wright Tool Co.

W. C. Snyder, *Alternate*, Wright Tool Co.

SUBCOMMITTEE 6: SCREWDRIVERS

J. S. Foote, *Chair*, Trade Association Management, Inc.

J. Davidson, Sears Roebuck and Co.

D. M. Eggert, Snap-on, Inc.

CORRESPONDENCE WITH THE B107 COMMITTEE

General. ASME Standards are developed and maintained with the intent to represent the consensus of concerned interests. As such, users of this Standard may interact with the Committee by requesting interpretations, proposing revisions, and attending Committee meetings. Correspondence should be addressed to:

Secretary, B107 Standards Committee
The American Society of Mechanical Engineers
Three Park Avenue
New York, NY 10016-5990

Proposing Revisions. Revisions are made periodically to the Standard to incorporate changes that appear necessary or desirable, as demonstrated by the experience gained from the application of the Standard. Approved revisions will be published periodically.

The Committee welcomes proposals for revisions to this Standard. Such proposals should be as specific as possible, citing the paragraph number(s), the proposed wording, and a detailed description of the reasons for the proposal, including any pertinent documentation.

Interpretations. Upon request, the B107 Committee will render an interpretation of any requirement of the Standard. Interpretations can only be rendered in response to a written request sent to the Secretary of the B107 Standards Committee.

The request for interpretation should be clear and unambiguous. It is further recommended that the inquirer submit his/her request in the following format:

- Subject: Cite the applicable paragraph number(s) and the topic of the inquiry.
Edition: Cite the applicable edition of the Standard for which the interpretation is being requested.
Question: Phrase the question as a request for an interpretation of a specific requirement suitable for general understanding and use, not as a request for an approval of a proprietary design or situation. The inquirer may also include any plans or drawings, which are necessary to explain the question; however, they should not contain proprietary names or information.

Requests that are not in this format may be rewritten in the appropriate format by the Committee prior to being answered, which may inadvertently change the intent of the original request.

ASME procedures provide for reconsideration of any interpretation when or if additional information that might affect an interpretation is available. Further, persons aggrieved by an interpretation may appeal to the cognizant ASME Committee or Subcommittee. ASME does not “approve,” “certify,” “rate,” or “endorse” any item, construction, proprietary device, or activity.

Attending Committee Meetings. The B107 Standards Committee regularly holds meetings, which are open to the public. Persons wishing to attend any meeting should contact the Secretary of the B107 Standards Committee.