

AMERICAN NATIONAL STANDARD

# Metric Series Hexagon Keys and Bits

---

ANSI B18.3.2M - 1979

For Socket Screw Products

**REAFFIRMED 1990**

FOR CURRENT COMMITTEE PERSONNEL  
PLEASE SEE ASME MANUAL AS-11

**SECRETARIAT**

SOCIETY OF AUTOMOTIVE ENGINEERS  
THE AMERICAN SOCIETY OF MECHANICAL ENGINEERS

**REAFFIRMED 1998**

FOR CURRENT COMMITTEE PERSONNEL  
PLEASE SEE ASME MANUAL AS-11

*PUBLISHED BY*

THE AMERICAN SOCIETY OF MECHANICAL ENGINEERS

United Engineering Center

345 East 47th Street

New York, N. Y. 10017

## AMERICAN NATIONAL STANDARD

**METRIC SERIES HEXAGON KEYS AND BITS****1 GENERAL****1.1 Scope**

1.1.1 This standard contains the complete dimensional, mechanical and performance requirements for Metric Series Hexagon Keys and Bits of nominal sizes from 0.7 mm to 36 mm recognized as "American National Standard." They are primarily intended to be used for tightening and loosening metric series hexagon socket screw products but may also be suitable for use on other products having metric hexagon socket wrenching provisions.

1.1.2 The inclusion of dimensional data in this standard is not intended to imply that all the products described are stock production sizes. Consumers are requested to consult with manufacturers concerning lists of stock production sizes.

**1.2 Interchangeability with ISO Keys**

1.2.1 Dimensions. Keys in 2.5 mm and larger nominal sizes produced to this standard will conform dimensionally to International Standard, Assembly Tools for Screws, Bolts and Nuts—Hexagon Socket Screw Keys—Metric Series, ISO 2936-1973. At present, ISO 2936 does not cover nominal key sizes smaller than 2.5 mm.

1.2.2 Strength. The strength capability of keys made to the ISO 2936 standard is such that the keys are not considered suitable for driving high strength screws, such as property class 12.9 hexagon socket cap screws and property class 45H hexagon socket set screws.

**1.3 Large Keys and Bits**

For nominal socket sizes above 24 mm it is recommended that bits be used in conjunction with standard hexagon wrenches or power drives. When the application makes the use of keys necessary the keys should conform to the dimensions specified herein. Bits are

available in nominal sizes 24 mm and smaller but the lengths have not been standardized.

**1.4 Dimensions**

All dimensions in this standard are given in millimeters (mm) unless otherwise stated. For plated hexagon keys or bits all dimensions are before plating.

**1.5 Options**

Options, where specified, shall be at the discretion of the manufacturer unless otherwise agreed upon by manufacturer and purchaser.

**1.6 Responsibility for Modification**

The manufacturer shall not be held responsible for malfunctions of product determined to be due to plating or other modification when such plating or modification is not accomplished under his control or direction.

**1.7 Marking**

Hexagon keys in nominal sizes 2 mm to 10 mm, inclusive, shall be permanently and legibly marked with the nominal size and manufacturer's identification. On nominal sizes larger than 10 mm markings shall be optional.

**1.8 Designation**

Hexagon keys and bits shall be designated by the following data in the sequence shown:

Specification (ANSI document) number, followed by a dash; nominal key (or bit) size; Product name; series (for keys); and protective coating, if required.

*Examples:*

B18.3.2 6 mm Hexagon Key, Short Series

B18.3.2 8 mm Hexagon Key, Long Series, Nickel Plated

B18.3.2 32 mm Hexagon Bit



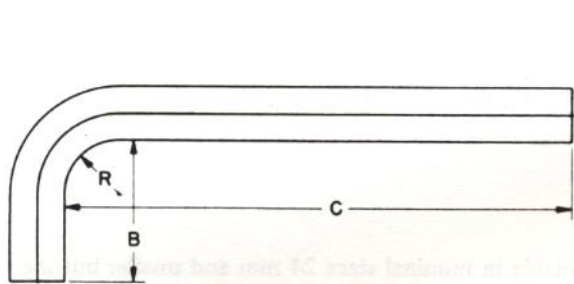

FIG. 1 KEY

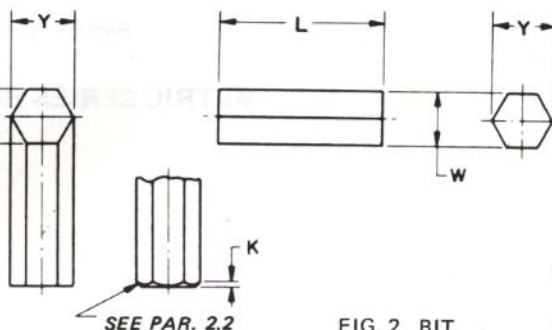

FIG. 2 BIT

Table 1 Dimensions of Metric Hexagon Keys and Bits

Nominal Key or Bit and Socket Size	W		Y		B		C				R	L	K
	Hexagon Width Across Flats		Hexagon Width Across Corners		Length of Short Arm		Length of Long Arm				Radius of Bend	Length of Bit ± 1.5	Chamfer Length Max
	Max	Min	Max	Min	Max	Min	Short Series		Long Series				
							Max	Min	Max	Min			
0.7	0.711	0.698	0.798	0.762	8	3	34	28	69	63	1.5	—	0.08
0.9	0.899	0.876	0.998	0.960	11	6	34	28	71	65	1.5	—	0.10
1.3	1.270	1.244	1.422	1.372	16	11	44	39	75	69	1.5	—	0.14
1.5	1.500	1.470	1.690	1.640	14	13	45	43	78	76	1.5	—	0.14
2	2.000	1.970	2.250	2.200	16	15	50	48	83	81	2.0	—	0.14
2.5	2.500	2.470	2.820	2.770	18	17	56	53	90	87	2.5	—	0.14
3	3.000	2.960	3.399	3.340	20	18	63	60	100	97	3.0	—	0.18
4	4.000	3.960	4.532	4.470	25	23	70	66	106	102	4.0	—	0.24
5	5.000	4.960	5.690	5.630	28	26	80	76	118	114	5.0	—	0.30
6	6.000	5.950	6.828	6.760	32	30	90	86	140	136	6.0	—	0.36
8	8.000	7.950	9.136	9.030	36	34	100	95	160	155	8.0	—	0.49
10	10.000	9.950	11.470	11.340	40	38	112	106	170	164	10.0	—	0.62
12	12.000	11.950	13.764	13.590	45	43	125	119	212	206	12.0	—	0.76
14	14.000	13.930	16.058	15.880	56	53	140	133	236	229	14.0	—	0.85
17	17.000	16.930	19.499	19.300	63	60	160	152	250	242	17.0	—	1.04
19	19.000	18.930	21.793	21.580	70	67	180	171	280	271	19.0	—	1.16
22	22.000	21.930	25.234	25.000	80	76	200	190	335	325	22.0	—	1.36
24	24.000	23.930	27.525	27.240	90	86	224	213	375	364	24.0	—	1.49
27	27.000	26.870	30.969	30.710	100	95	250	238	—	—	27.0	100.0	1.68
32	32.000	31.840	36.704	36.430	125	119	315	300	—	—	32.0	100.0	1.99
36	36.000	35.840	41.292	40.900	140	133	355	338	—	—	36.0	100.0	2.25

For additional requirements refer to applicable paragraphs in the text on Pages 1, 3 and 4.

## 2 DIMENSIONAL CHARACTERISTICS

The following requirements supplement the dimensional data presented in Table 1 and shall apply to the respective features of keys and bits.

### 2.1 Truncation of Hexagon Corners

The truncation or rounding of the hexagon corners within the specified width across corners dimensions shall be evident on all corners.

### 2.2 Ends

Each end shall be perpendicular to the axis of the respective arms of keys and the longitudinal axis of bits within 4 deg and the edges may be sharp radiused or chamfered at the option of the manufacturer. Where ends are chamfered, the length of the chamfer shall not exceed the values listed for "K" in Table 1.

### 2.3 Angle of Bend

The angle of bend between the axis of the short arm and the axis of the long arm on hexagon keys shall be  $\pm 2$  deg.

## 3 MATERIAL, PROCESSING AND MECHANICAL PROPERTIES

Keys and bits shall conform to the following requirements pertaining to materials, processing, mechanical and physical properties, and testing and sampling procedures:

### 3.1 Material and Heat Treatment

Hexagon keys and bits shall be fabricated from an alloy steel having two or more of the following alloying elements: chromium, nickel, molybdenum or vanadium in sufficient quantity to assure that the mechanical and physical requirements specified under Paragraph 3.3 can be met when the keys and bits are hardened by quenching from the austenitizing temperature and tempered.

### 3.2 Finish

The finish on keys and bits shall be an oiled black oxide coating or the oxide coating resulting from heat treatment, unless otherwise specified by the purchaser.

### 3.3 Mechanical and Physical Requirements

**3.3.1 Hardness.** Hexagon keys and bits will have a hardness range of Rockwell C50 to C57 for nominal sizes up to and including 12 mm, and Rockwell C45 to C53 for sizes 13 mm and larger. For sizes 2 mm

and smaller, the microhardness requirement is Knoop 565 to 685 or the Vickers' equivalent.

**3.3.2 Torsional Strength.** Hexagon keys and bits when subjected to the torsional strength test defined in Paragraph 3.3.2.1 shall withstand the torsional moments specified in Table 2 without taking a permanent angular deflection or set of more than 10 deg. The test key or bit shall not exhibit any flaws, cracks or other defects which might affect its serviceability and the portion engaged in the socket shall show no distortion or rounding of corners.

For nominal sizes up to and including 8 mm, the key or bit shall be further tested to failure in accordance with the torsional shear test described in Paragraph 3.3.2.2. The failure shall occur as a clean and relatively square, shear fracture. Any splintering or brittle type failures shall be cause for rejection.

**Table 2 Torsional Moments for Torsional Strength Test**

Nominal Key Size	Torsional Moment N·m	Nominal Key Size	Torsional Moment N·m
0.7	0.1	10	252
0.9	0.2	12	420
1.3	0.6	14	670
1.5	1.0	17	1180
2	2.1	19	1670
2.5	4.7	22	2450
3	7.7	24	3200
4	17.8	27	4300
5	35	32	6800
6	57	36	10000
8	126		

**3.3.2.1 Torsional Strength Test.** The key or bit shall be inserted into a hexagon socket adapter designed for the size being tested. See Figure 3. The socket size in the adapter shall not exceed the nominal hexagon size by more than 0.025 mm and the adapter shall have a hardness of Rockwell C60 or greater for nominal sizes up to and including 14 mm and Rockwell C45 minimum for sizes larger than 14 mm. The depth of key engagement shall be equal to the nominal key size for the 1.5 mm and larger sizes and equivalent to 1.5 times the nominal key sizes for sizes smaller than 1.5 mm. With the socket adapter mounted in a suitable test fixture (see Figure 4), a torsional moment equal to 20 percent of that listed in Table 2 shall be applied to the key or bit, then released. The angular reference line thereby established shall be recorded.



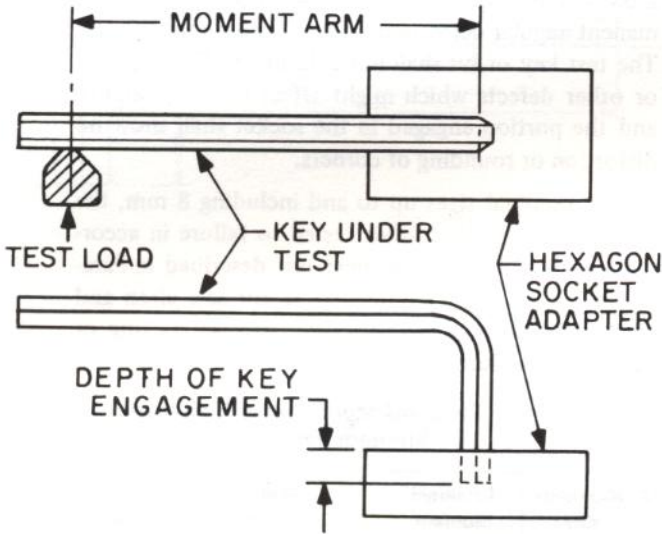

FIGURE 3. TORSIONAL MOMENT LOAD APPLICATION

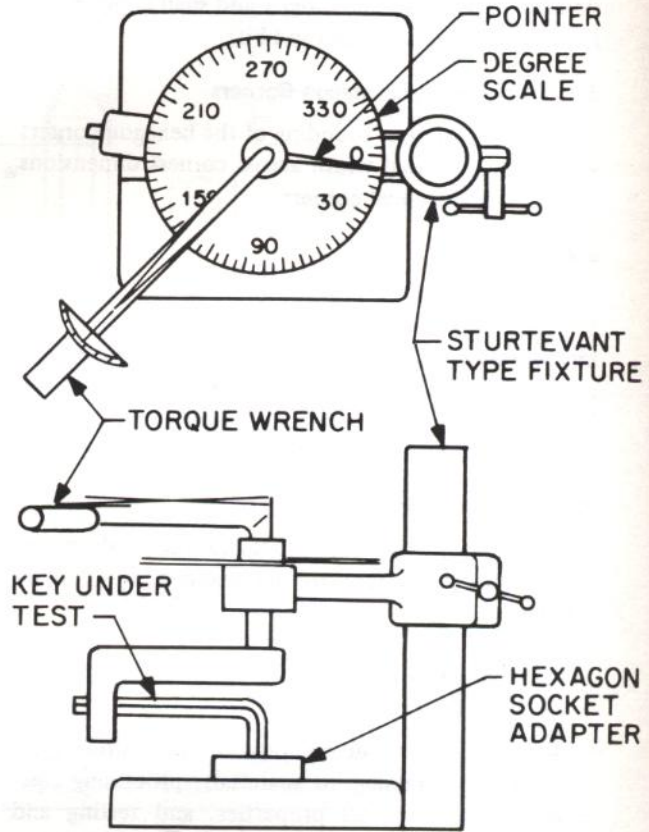

FIGURE 4. TYPICAL TORSIONAL STRENGTH TEST FIXTURE

The full torsional moment given in Table 2 shall be applied, then released, and the resulting angular displacement noted. The permanent set (difference between the angular readings) shall be determined and the test specimen examined.

**3.3.2.2 Torsional Shear Test.** For sizes up to and including 8 mm, the test key or bit shall be reinserted into the hexagon socket adapter in the torsional strength test fixture to a depth at least equal to that specified in Paragraph 3.3.2.1. The torsional moment shall be increased until the key or bit fails and the fracture examined to determine compliance with Paragraph 3.3.2.

**3.3.3 Sample Size.** The tests required under Paragraphs 3.3.1 and 3.3.2 shall be performed on a random sample size selected in accordance with Table 3.

Table 3 Sample Size for Mechanical Testing

Lot Quantity	Sample Size
Up to 50	2
51 to 500	3
501 to 35 000	5
Over 35 000	8

# CONTENTS

1. General . . . . .	1
2. Dimensional Characteristics . . . . .	3
3. Material, Processing, and Mechanical Properties . . . . .	3

## TABLES

1. Dimensions for Metric Hexagon Keys and Bits . . . . .	2
2. Torsional Moments for Torsional Strength Test . . . . .	3
3. Sample Size for Mechanical Testing . . . . .	4

# AMERICAN NATIONAL STANDARDS COMMITTEE B18

## Standardization of Bolts, Nuts, Rivets, Screws, Washers and Similar Fasteners

### OFFICERS

**R. P. Trowbridge, Chairman**  
**J. B. Levy, Vice-Chairman**  
**H. G. Muenchinger, Vice-Chairman**  
**R. McGinnis, Secretary**

### COMMITTEE PERSONNEL

#### AMERICAN CHAIN ASSOCIATION

*L. E. Hampel, Moline Malleable Iron Company, St. Charles, Illinois*

#### AMERICAN HARDWARE MANUFACTURERS ASSOCIATION

*Donald Wanek, Wrought Washer Manufacturing Company, Milwaukee, Wisconsin*

#### AMERICAN INSTITUTE OF INDUSTRIAL ENGINEERS

*R. T. Kelly, Hitchcock Publishing Company, Wheaton, Illinois*

#### AMERICAN SOCIETY OF AGRICULTURAL ENGINEERS

*E. R. Friesth, Deere & Company, Moline, Illinois*

*J. H. Zich, Alternate, Ford Motor Company, Troy, Michigan*

#### AMERICAN SOCIETY OF MECHANICAL ENGINEERS, THE

*A. R. Machell, Jr., Xerox Corporation, Rochester, New York*

*F. P. Tisch, Desert Hot Springs, California*

*R. P. Trowbridge, General Motors Technical Center, Warren, Michigan*

*C. R. Adams, Alternate, Newport News Shipbuilding & Dry Dock Company, Newport News, Virginia*

*K. E. McCullough, Alternate, SPS Technologies, Jenkintown, Pennsylvania*

#### ANTI-FRICTION BEARING MANUFACTURERS ASSOCIATION

*W. J. Derner, FMC Corporation, Indianapolis, Indiana*

#### ENGINE MANUFACTURERS ASSOCIATION

*K. F. Naylor, Cummins Engine Company, Columbus, Indiana*

#### FARM & INDUSTRIAL EQUIPMENT INSTITUTE

*E. R. Friesth, Deere & Company, Moline, Illinois*

#### HAND TOOLS INSTITUTE

*C. B. Ingersoll, J. H. Williams Company, Buffalo, New York*

#### INDUSTRIAL FASTENERS INSTITUTE

*R. B. Belford, Industrial Fasteners Institute, Cleveland, Ohio*

*A. R. Breed, The Lamson & Sessions Company, Cleveland, Ohio*

*E. J. Heldmann, Holo-Krome Company, West Hartford, Connecticut*

*D. A. Garrison, Russell, Burdsall & Ward, Inc., Rock Falls, Illinois*

*R. W. Groover, Bethlehem Steel Company, Lebanon, Pennsylvania*

*Jack Shugart, Rockford Products Corporation, Rockford, Illinois*

*D. P. Wagner, Illinois Tool Works, Inc., Elgin, Illinois*

*D. D. Wheeler, Armco Steel Corporation, Kansas City, Missouri*

*N. W. Bellas, Alternate, Illinois Tool Works, Inc., Elgin, Illinois*

*R. M. Harris, Alternate, Bethlehem Steel Corporation, Lebanon, Pennsylvania*

*F. R. Ling, Alternate, Russell, Burdsall & Ward, Inc., Mentor, Ohio*

*A. J. Parker, Alternate, The Lamson & Sessions Company, Cleveland, Ohio*



## METAL CUTTING TOOL INSTITUTE

*Dino Emanuelli*, Greenfield Tap & Die, Greenfield, Massachusetts

## NATIONAL ELECTRICAL MANUFACTURERS ASSOCIATION

*J. B. Levy*, General Electric Company, Schenectady, New York

*F. F. Weingruber*, Westinghouse Electric Corporation, Pittsburgh, Pennsylvania

*F. K. Kitzantides*, National Electrical Manufacturers Association, Washington, D.C.

## NATIONAL ELEVATOR INDUSTRY, INC.

*R. J. Cummings*, Otis Elevator Company, Mahwah, New Jersey

## SOCIETY OF AUTOMOTIVE ENGINEERS

*H. W. Ellison*, General Motors Corporation, Warren, Michigan

*S. E. Mallen*, Ford Motor Company, Dearborn, Michigan

*R. S. Piotrowski*, Mack Trucks, Inc., Allentown, Pennsylvania

*C. F. Schaening*, General Motors Engineering Standard Section, Warren, Michigan

*R. R. Sjoberg*, International Harvester Company, Hinsdale, Illinois

*D. W. Vial*, Chrysler Corporation, Detroit, Michigan

## SOCKET SCREW PRODUCTS BUREAU

*E. R. Carter, Jr.*, The Allen Manufacturing Company, Hartford, Connecticut

*Ernest Heldmann*, Holo-Krome Company, West Hartford, Connecticut

*Jack Trilling*, Great Lakes Screw, Chicago, Illinois

## TELEPHONE GROUP

*R. A. Agnew*, Western Electric Company, Chicago, Illinois

*R. H. Van Horn*, Bell Laboratory, Columbus, Ohio

*H. Haefeli, Alternate*, Bell Laboratory, Columbus, Ohio

## TUBULAR & MACHINE INSTITUTE

*J. G. Zeratsky*, National Rivet & Manufacturing Company, Waupun, Wisconsin

## U.S. DEPARTMENT OF THE AIR FORCE

To be appointed

## U.S. DEPARTMENT OF THE ARMY

*M. E. Taylor*, U.S. Army Armament R & D Command, Dover, New Jersey

*Allen Herskovitz, Alternate*, U.S. Army Armament R & D Command, Dover, New Jersey

## U.S. DEPARTMENT OF DEFENSE

*Eli Schwartz*, Defense Industrial Supply Center, Philadelphia, Pennsylvania

*Lewis Pieninck*, Defense Industrial Supply Center, Philadelphia, Pennsylvania

## U.S. DEPARTMENT OF THE NAVY

*J. S. Ruff*, Department of the Navy, Washington, D.C.

*M. S. Orysh, Alternate*, Department of the Navy, Philadelphia, Pennsylvania

## U.S. MACHINE CAP WOOD & TAPPING SCREW BUREAUS

*S. C. Adamek*, Pheoll Manufacturing Company, Chicago, Illinois

*R. M. Byrne*, U.S. Screw Service Bureaus, New York, New York

*T. J. Ferry*, E. W. Ferry Screw Products Company, Inc., Cleveland, Ohio

*Casey Gordon*, Parker-Kalon, Campbellsville, Kentucky

*Herman Muenchinger*, Continental Screw Company, New Bedford, Massachusetts

*K. D. Ringland*, Parker-Kalon Fastener Division, USM Corporation, Campbellsville, Kentucky

*R. H. Seymour*, Reed & Prince Manufacturing Company, Worcester, Massachusetts

*Louis Zanin*, Elco Industries, Inc., Rockford, Illinois

*Paul Foytho, Alternate*, Harvey Hubbel, Inc., Bridgeport, Connecticut

## INDIVIDUAL COMPANIES

*J. J. Naeset*, Clark Equipment Company, Battle Creek, Michigan

*R. W. Bertoia*, The Ohio Nut & Washer Company, Mingo Junction, Ohio

*E. D. Cowlin*, Canton, Ohio

*J. E. Eaton, Jr.*, IBM Corporation, Boulder, Colorado

*Jules Freedman*, G. K. Garrett Company, Philadelphia, Pennsylvania

*D. M. McCarthy*, Ford Motor Company, Dearborn, Michigan

*J. F. Tornow*, Microdot Inc., Troy, Michigan



## INDIVIDUAL MEMBERS

*C. O. Franklin*, Valley Bolt Company, Marion, Iowa

*F. E. Graves*, Fairfield, Connecticut

## PERSONNEL OF SUBCOMMITTEE NO. 3 SOCKET HEAD CAP AND SET SCREWS

*Jack Trilling, Chairman*, Great Lakes Screw, Chicago, Illinois

*John Akins*, Safety Socket Screw Corporation, Chicago, Illinois

*J. J. Naeset*, Clark Equipment Company, Battle Creek, Michigan

*R. B. Belford*, Industrial Fasteners Institute, Cleveland, Ohio

*Henry Bobrowski*, Kerr-Lakeside, Inc., Cleveland, Ohio

*R. M. Byrne*, Socket Screw Products Bureau, New York, New York

*Russ Carter*, Allen Manufacturing Company, Hartford, Connecticut

*E. J. Heldmann*, Holo-Krome Screw Corporation, Hartford, Connecticut

*D. T. Lipari*, Bell Telephone Laboratory, Columbus, Ohio

*A. R. Machell, Jr.*, Xerox Corporation, Rochester, New York

*James Marek*, Stanadyne, Inc., Garrett, Indiana

*K. E. McCullough*, SPS Technologies, Jenkintown, Pennsylvania

*Lewis Pieninck*, Defense Supply Agency, Philadelphia, Pennsylvania

*C. F. Schaening*, General Motors Technical Center, Warren, Michigan

*M. E. Taylor*, U.S. Army Armament R & D Command, Dover, New Jersey

*F. F. Weingruber*, Westinghouse Electric Corporation, Pittsburgh, Pennsylvania

*Larry Harkins, Alternate*, Defense Supply Agency, Philadelphia, Pennsylvania

*Allen Herskovitz, Alternate*, U.S. Army Armament R&D Command, Dover, New Jersey