

**1.5MHz STEP-UP DC-DC CONVERTER****AP3012****General Description**

The AP3012 is a high power, constant frequency, current mode PWM, inductor based, step-up (boost) converter. The converter operates at high frequency (1.5MHz) so that a small, low profile inductor can be used.

The AP3012 has built-in overvoltage protection (OVP) to allow the device goes into shutdown mode when the output voltage exceeds the OVP threshold of 29V.

The AP3012 is available in standard SOT-23-5 package.

Features

- High Efficiency up to 81%
- Adjustable Output Voltage Range up to 29V
- Shutdown Current 1 μ A Typical
- 1.5MHz Switching Frequency
- 36V 500mA Rugged Integrated Bipolar Switch
- Built-in Soft-Start to Reduce Inrush Current During Start-up
- On-chip Overvoltage Protection
- Uses Small Output Capacitor
- Uses Low Profile 1mm Tall Inductor

Applications

- LCD/OLED Display Bias Supply
- White LED Driver for LCD Display Backlights
- Cellular Phones

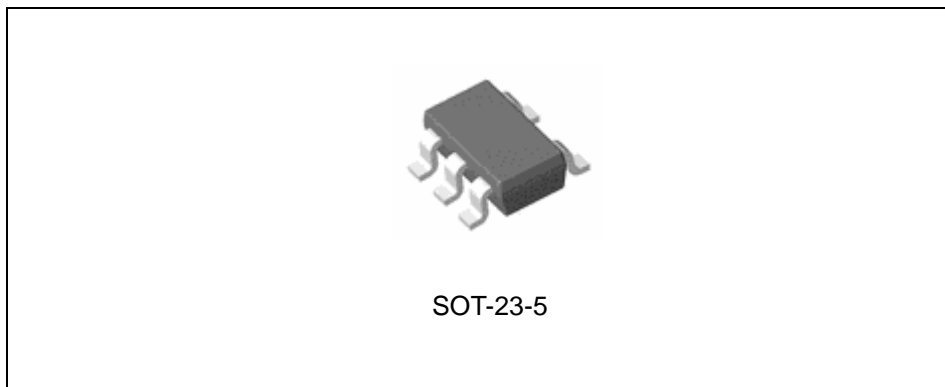

Figure 1. Package Type of AP3012

**1.5MHz STEP-UP DC-DC CONVERTER****AP3012****Pin Configuration**

Figure 2. Pin Configuration of AP3012 (Top View)

Pin Description

Pin Number	Pin Name	Function
1	SW	Switch Pin. Connect inductor/diode here. The output voltage can go up to 29V but should not exceed this limit. If the voltage on this pin is higher than the overvoltage protection (OVP) threshold, the device can go into shutdown mode. It can be restarted by a low to high pulse on the \overline{SHDN} pin, or by a power on reset on the V_{IN} supply.
2	GND	Ground Pin. Connect directly to local ground plane.
3	FB	Feedback Pin. Internally compares to 1.25V. Connect R1 and R2 resistor divider here. Calculate the Output Voltage according to the formula: $V_{OUT}=1.25V * (1+R1/R2)$.
4	\overline{SHDN}	Shutdown Pin. Connect to 1.5V or higher to enable device (ON), 0.4V or lower to disable device (OFF).
5	V_{IN}	Input Supply Pin. Must be locally bypassed.

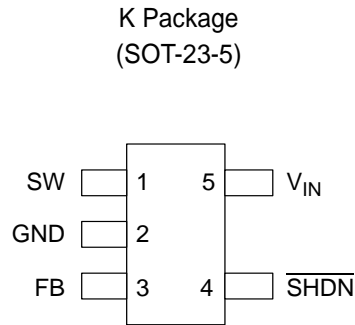

1.5MHz STEP-UP DC-DC CONVERTER

AP3012

Functional Block Diagram

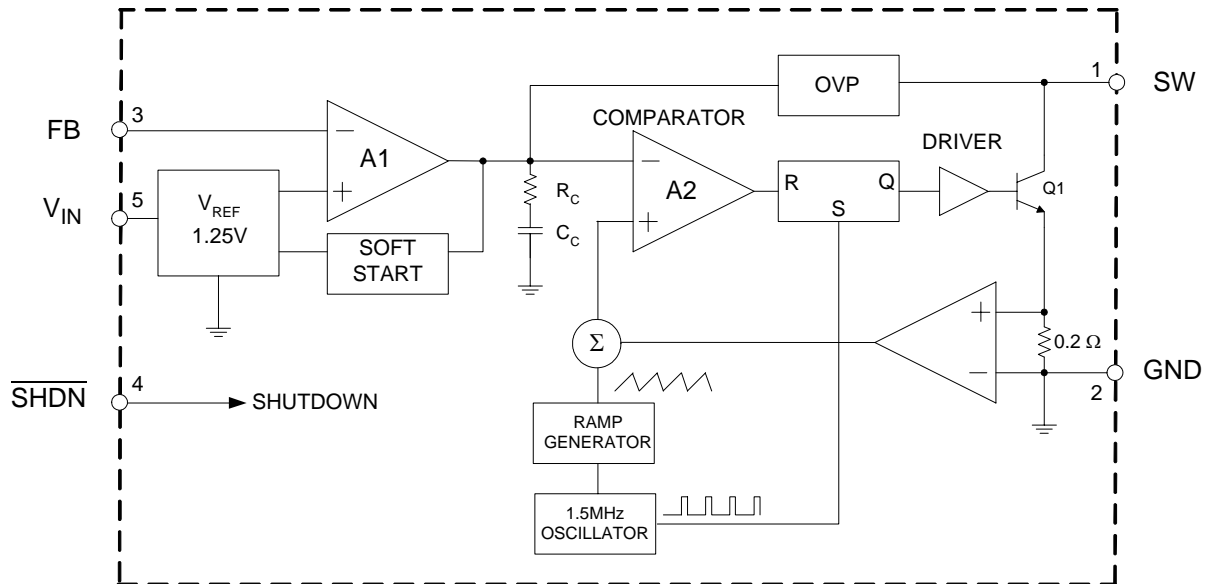

Figure 3. Functional Block Diagram of AP3012



1.5MHz STEP-UP DC-DC CONVERTER

AP3012

Ordering Information

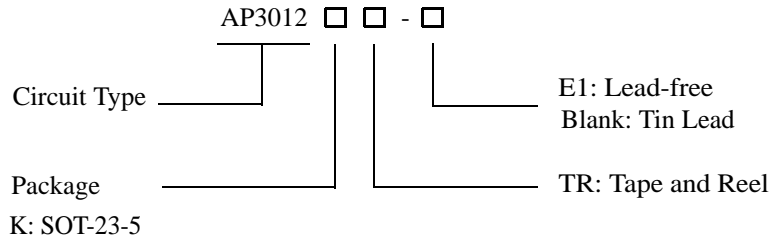

Package	Temperature Range	Part Number		Marking ID		Packing Type
		Tin Lead	Lead Free	Tin Lead	Lead Free	
SOT-23-5	-40 to 85°C		AP3012KTR-E1		E6B	Tape & Reel

BCD Semiconductor's Pb-free products, as designated with "E1" suffix in the part number, are RoHS compliant.

**1.5MHz STEP-UP DC-DC CONVERTER****AP3012****Absolute Maximum Ratings (Note 1)**

Parameter	Symbol	Value	Unit
Input Voltage	V_{IN}	16	V
SW Voltage		38	V
FB Voltage		5	V
SHDN Voltage		16	V
Maximum Junction Temperature		125	°C
Storage Temperature Range	T_{STG}	-65 to 150	°C
Lead Temperature (Soldering, 10sec)	T_{LEAD}	300	°C
Power Dissipation (Derate 6.67mW/°C above 70°C)		460	mW

Note 1: Stresses greater than those listed under "Absolute Maximum Ratings" may cause permanent damage to the device. These are stress ratings only, and functional operation of the device at these or any other conditions beyond those indicated under "Recommended Operating Conditions" is not implied. Exposure to "Absolute Maximum Ratings" for extended periods may affect device reliability.

Recommended Operating Conditions

Parameter	Symbol	Min	Max	Unit
Operating Temperature	T_{OP}	-40	85	°C

**1.5MHz STEP-UP DC-DC CONVERTER****AP3012****Electrical Characteristics** $(V_{IN}=3V, \overline{V_{SHDN}}=3V, T_A=25^{\circ}C, \text{ unless otherwise specified.})$

Parameter	Symbol	Conditions	Min	Typ	Max	Unit
Minimum Operating Voltage			2.6			V
Maximum Operating Voltage					16	V
Feedback Voltage	V_{FB}	$V_{IN}=5V, V_{OUT}=24V, I_{OUT}=30mA$	1.17	1.25	1.33	V
FB Pin Bias Current		$V_{FB}=1.25V$	10	45	100	nA
Supply Current		$V_{FB}=V_{IN}$		2.5	3.5	mA
		$\overline{V_{SHDN}}=0V, V_{FB}=0V$		0.1	1.0	μA
Switching Frequency			1.1	1.5	1.9	MHz
Maximum Duty Cycle			85	90		%
Switching Current Limit		Duty Cycle=80%		500		mA
Switch V_{CESAT}		$I_{SW}=250mA$		300		mV
Switch Leakage Current		$V_{SW}=5V$		0.01	5	μA
\overline{SHDN} Voltage High (ON)			1.5			V
\overline{SHDN} Voltage Low (OFF)					0.4	
\overline{SHDN} Pin Bias Current				55		μA
OVP Voltage Threshold				29		V
Soft-Start Time				550		μS



1.5MHz STEP-UP DC-DC CONVERTER

AP3012

Typical Performance Characteristics

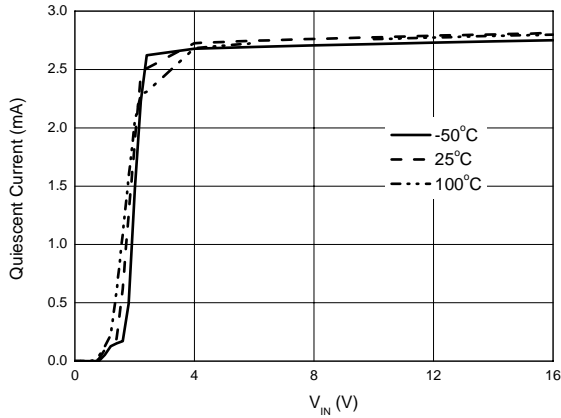

Figure 4. Quiescent Current vs. Input Voltage

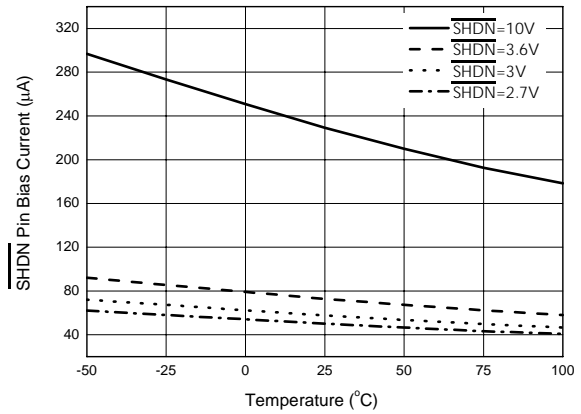

Figure 5. SHDN Pin Bias Current vs. Temperature

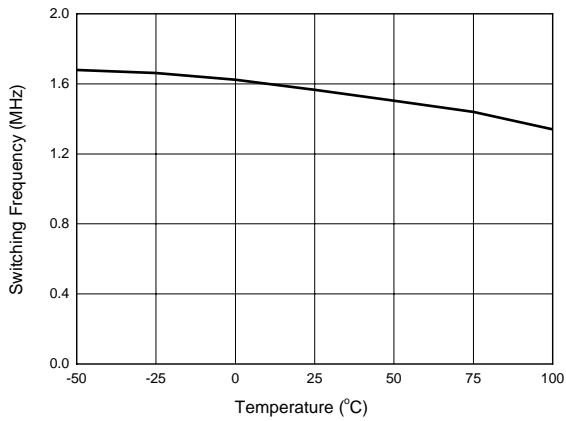

Figure 6. Switching Frequency vs. Temperature

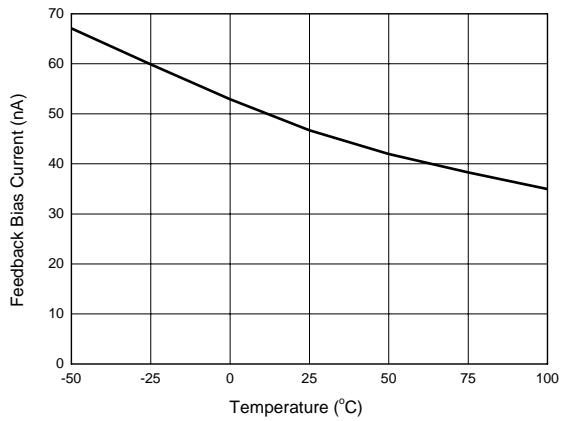

Figure 7. Feedback Bias Current vs. Temperature



1.5MHz STEP-UP DC-DC CONVERTER

AP3012

Typical Performance Characteristics (Continued)

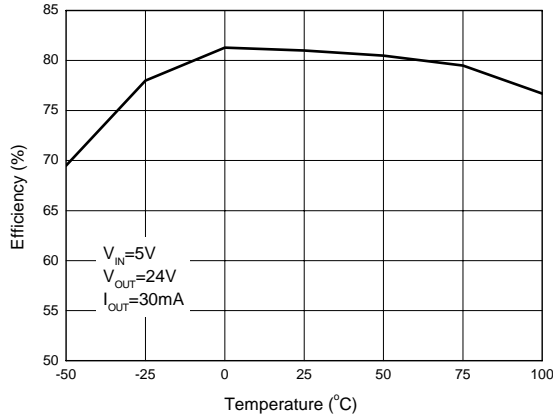

Figure 8. Efficiency vs. Temperature

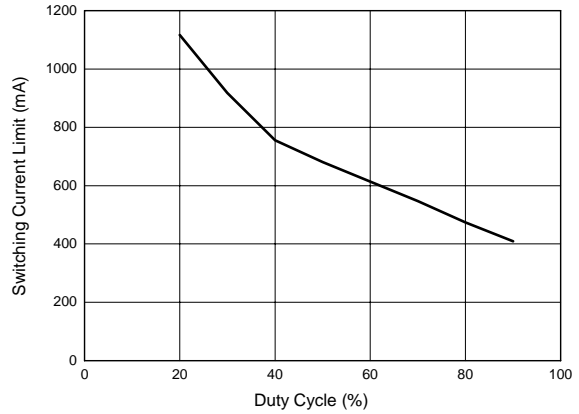

Figure 9. Switching Current Limit vs. Duty Cycle

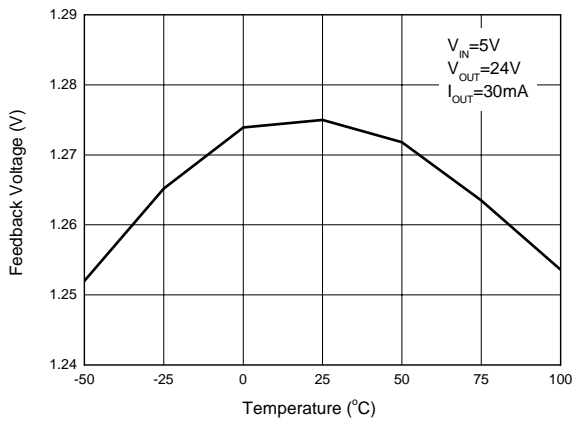

Figure 10. Feedback Voltage vs. Temperature

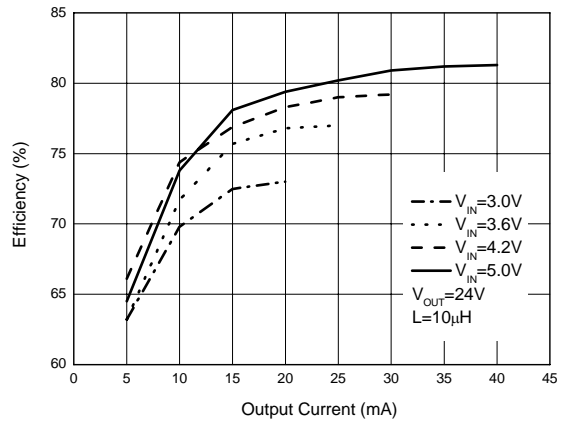

Figure 11. Efficiency vs. Output Current



1.5MHz STEP-UP DC-DC CONVERTER

AP3012

Typical Application

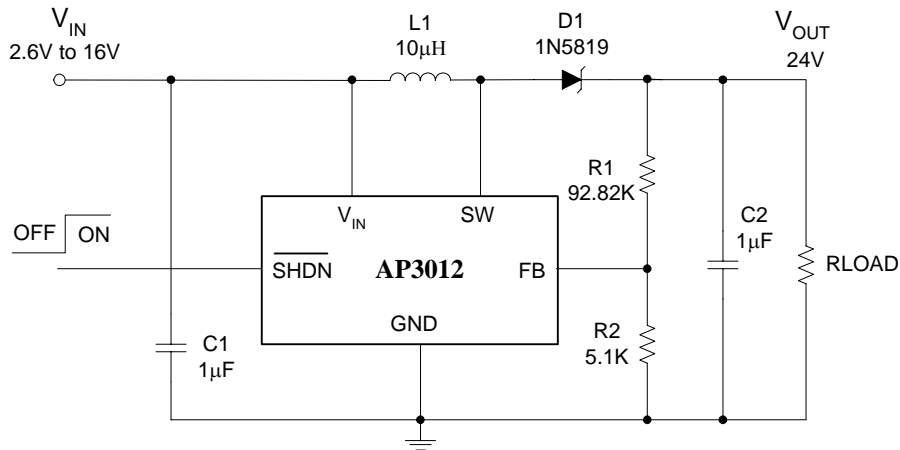

Note: $V_{OUT} = 1.25 * (1 + R1/R2) = 1.25 * 19.2 = 24V$

Figure 12. LCD/OLED Display Bias Driver Typical Circuit



1.5MHz STEP-UP DC-DC CONVERTER

AP3012

Mechanical Dimensions

SOT-23-5

Unit: mm(inch)

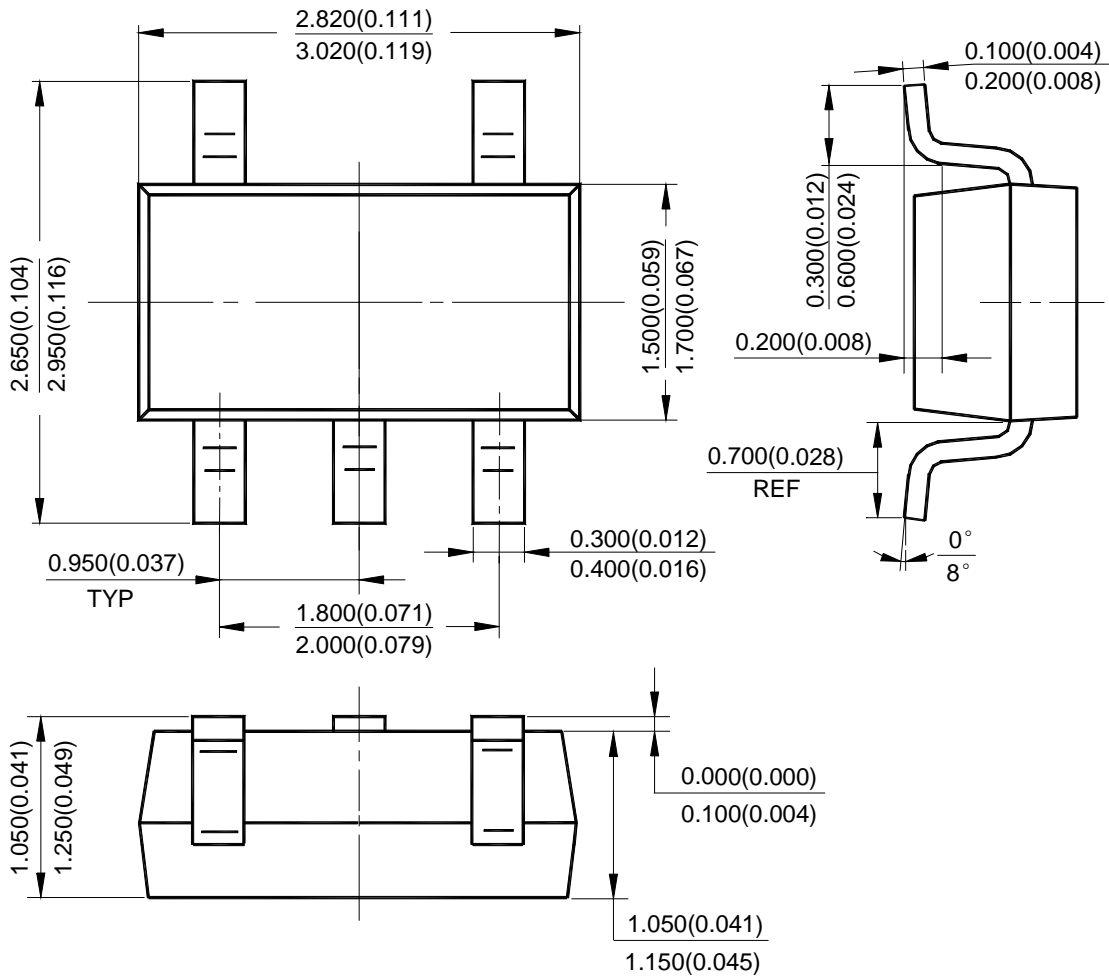



BCD Semiconductor Manufacturing Limited

<http://www.bcdsemi.com>

IMPORTANT NOTICE

BCD Semiconductor Manufacturing Limited reserves the right to make changes without further notice to any products or specifications herein. BCD Semiconductor Manufacturing Limited does not assume any responsibility for use of any its products for any particular purpose, nor does BCD Semiconductor Manufacturing Limited assume any liability arising out of the application or use of any its products or circuits. BCD Semiconductor Manufacturing Limited does not convey any license under its patent rights or other rights nor the rights of others.

MAIN SITE

BCD Semiconductor Manufacturing Limited
- Wafer Fab
Shanghai SIM-BCD Semiconductor Manufacturing Limited
800, Yi Shan Road, Shanghai 200233, China
Tel: +86-21-6485 1491, Fax: +86-21-5450 0008

BCD Semiconductor Manufacturing Limited
- IC Design Group
Advanced Analog Circuits (Shanghai) Corporation
8F, Zone B, 900, Yi Shan Road, Shanghai 200233, China
Tel: +86-21-6495 9539, Fax: +86-21-6485 9673

REGIONAL SALES OFFICE

Shenzhen Office
Shanghai SIM-BCD Semiconductor Manufacturing Co., Ltd. Shenzhen Office
Advanced Analog Circuits (Shanghai) Corporation Shenzhen Office
27B, Tower C, 2070, Middle Shen Nan Road, Shenzhen 518031, China
Tel: +86-755-8368 3987, Fax: +86-755-8368 3166

Taiwan Office
BCD Semiconductor (Taiwan) Company Limited
4F, 298-1, Rui Guang Road, Nei-Hu District, Taipei,
Taiwan
Tel: +886-2-2656 2808, Fax: +886-2-2656 2806

USA Office
BCD Semiconductor Corporation
3170 De La Cruz Blvd., Suite 105, Santa Clara,
CA 95054-2411, U.S.A
Tel: +1-408-988 6388, Fax: +1-408-988 6386