

Hand-held motor-operated electric tools — Safety —

Part 2-11: Particular requirements for reciprocating saws (jig and sabre saws)

The European Standard EN 60745-2-11:2003 has the status of a British Standard

ICS 35.140.20

BS EN
60745-2-11:
2003

BSi
British Standards

National foreword

This British Standard is the official English language version of EN 60745-2-11:2003. It was derived by CENELEC from IEC 60745-2-11:2003. It supersedes BS EN 50144-2-10:2001, BS EN 50144-2-11:1997 and BS EN 50260-2-10:2002 which will be withdrawn on 2006-02-01.

The CENELEC common modifications have been implemented at the appropriate places in the text and are indicated by tags $\text{\textcircled{E}}$ $\text{\textcircled{C}}$.

The UK participation in its preparation was entrusted by Technical Committee CPL/61, Safety of household and similar electrical appliances, to Subcommittee CPL/61/6, Portable motor operated tools, which has the responsibility to:

- aid enquirers to understand the text;
- present to the responsible international/European committee any enquiries on the interpretation, or proposals for change, and keep the UK interests informed;
- monitor related international and European developments and promulgate them in the UK.

A list of organizations represented on this subcommittee can be obtained on request to its secretary.

Cross-references

The British Standards which implement international or European publications referred to in this document may be found in the *BSI Catalogue* under the section entitled "International Standards Correspondence Index", or by using the "Search" facility of the *BSI Electronic Catalogue* or of British Standards Online.

This publication does not purport to include all the necessary provisions of a contract. Users are responsible for its correct application.

Compliance with a British Standard does not of itself confer immunity from legal obligations.

Summary of pages

This document comprises a front cover, an inside front cover, the EN title page, pages 2 to 10, an inside back cover and a back cover.

The BSI copyright notice displayed in this document indicates when the document was last issued.

Amendments issued since publication

Amd. No.	Date	Comments

This British Standard was published under the authority of the Standards Policy and Strategy Committee on 24 September 2003

© BSI 24 September 2003

ISBN 0 580 42631 9

EUROPEAN STANDARD

EN 60745-2-11

NORME EUROPÉENNE

EUROPÄISCHE NORM

August 2003

ICS 25.140.20

Supersedes EN 50144-2-10:2001 & EN 50144-2-11:1996 & EN 50260-2-10:2002

English version

**Hand-held motor-operated electric tools -
Safety**
**Part 2-11: Particular requirements for reciprocating saws
(jig and sabre saws)**
(IEC 60745-2-11:2003, modified)

Outils électroportatifs à moteur -
Sécurité
Partie 2-11: Règles particulières pour les
scies alternatives (scies sauteuses
et scies sabres)
(CEI 60745-2-11:2003, modifiée)

Handgeführte motorbetriebene
Elektrowerkzeuge -
Sicherheit
Teil 2-11: Besondere Anforderungen
für Sägen mit hin- und hergehendem
Sägeblatt (Stichsägen und Säbelsägen)
(IEC 60745-2-11:2003, modifiziert)

This European Standard was approved by CENELEC on 2003-02-01. CENELEC members are bound to comply with the CEN/CENELEC Internal Regulations which stipulate the conditions for giving this European Standard the status of a national standard without any alteration.

Up-to-date lists and bibliographical references concerning such national standards may be obtained on application to the Central Secretariat or to any CENELEC member.

This European Standard exists in three official versions (English, French, German). A version in any other language made by translation under the responsibility of a CENELEC member into its own language and notified to the Central Secretariat has the same status as the official versions.

CENELEC members are the national electrotechnical committees of Austria, Belgium, Czech Republic, Denmark, Finland, France, Germany, Greece, Hungary, Iceland, Ireland, Italy, Lithuania, Luxembourg, Malta, Netherlands, Norway, Portugal, Slovakia, Spain, Sweden, Switzerland and United Kingdom.

CENELEC

European Committee for Electrotechnical Standardization
Comité Européen de Normalisation Electrotechnique
Europäisches Komitee für Elektrotechnische Normung

Central Secretariat: rue de Stassart 35, B - 1050 Brussels

© 2003 CENELEC - All rights of exploitation in any form and by any means reserved worldwide for CENELEC members.

Ref. No. EN 60745-2-11:2003 E

Page 2

EN 60745-2-11:2003

Foreword

The text of the International Standard IEC 60745-2-11:2003, prepared by SC 61F, Safety of hand-held motor-operated electric tools, of IEC/TC 61, Safety of household and similar electrical appliances, together with the common modifications prepared by the Technical Committee CENELEC TC 61F, Safety of hand-held and transportable motor-operated electric tools was submitted to the formal vote and was approved by CENELEC as EN 60745-2-11 on 2003-02-01.

This European Standard supersedes EN 50144-2-10:2001, EN 50144-2-11:1996 and EN 50260-2-10:2002.

The following dates were fixed:

- latest date by which the EN has to be implemented at national level by publication of an identical national standard or by endorsement (dop) 2004-03-01
- latest date by which the national standards conflicting with the EN have to be withdrawn (dow) 2006-02-01

Other standards referred to in this European standard are listed in Clause 2. Clause 2 lists the valid edition of those documents at the time of issue of this EN.

This standard is divided into two parts:

Part 1: General requirements which are common to most hand-held electric motor operated tools (for the purpose of this standard referred to simply as tools) which could come within the scope of this standard;

Part 2: Requirements for particular types of tools which either supplement or modify the requirements given in Part 1 to account for the particular hazards and characteristics of these specific tools.

This European Standard has been prepared under a mandate given to CEN and CENELEC by the European Commission and the European Free Trade Association and supports the essential health and safety requirements of the Machinery Directive.

Compliance with the clauses of Part 1 together with this Part 2 provides one means of conforming with the essential health and safety requirements of the Directive concerned.

CEN/TC 255 is producing standards for non-electric reciprocating saws (EN 792-12).

Warning: Other requirements and other EC Directives can be applicable to the products falling within the scope of this standard.

This standard follows the overall requirements of EN 292-1 and EN 292-2.

This Part 2-11 is to be used in conjunction with EN 60745-1:2003. When this standard states "addition", "modification" or "replacement", the relevant text in Part 1 is to be adapted accordingly.

Subclauses and figures which are additional to those in Part 1 are numbered starting from 101.

Subclauses, tables and figures which are additional to those in IEC 60745-2-11 are prefixed "Z".

NOTE In this standard, the following print types are used:

- requirements: in roman type,
- test specifications: in italic type;
- notes: in smaller roman type.

Endorsement notice

The text of the International Standard IEC 60745-2-11:2003 was approved by CENELEC as a European Standard with agreed common modifications.

HAND-HELD MOTOR-OPERATED ELECTRIC TOOLS – SAFETY –

Part 2-11: Particular requirements for reciprocating saws (jig and sabre saws)

1 Scope

This clause of Part 1 is applicable, except as follows:

1.1 Addition:

This standard applies to reciprocating saws.

Tools covered by this standard include but are not limited to jigsaws and reciprocating saws (sabre saws).

2 Normative references

This clause of Part 1 is applicable.

3 Definitions

This clause of Part 1 is applicable, except as follows:

Additional definitions:

3.101

reciprocating saw

tool intended for cutting various material with a blade or blades acting in a reciprocating or oscillating motion

3.102

jigsaw

reciprocating saw equipped with a guide plate that may allow bevel adjustments

3.103

sabre saw

reciprocating saw equipped with or without a guide plate which may allow bevel adjustments

4 General requirements

This clause of Part 1 is applicable.

5 General conditions for the tests

This clause of Part 1 is applicable.

6 Environmental requirements

This clause of Part 1 is applicable except as follows:

6.1.2.4 Modification:

Reciprocating saws are suspended in such a way as to correspond to normal use.

6.1.2.5 Modification:

Reciprocating saws are tested at no-load.

6.2.2.4 Modification:

Reciprocating saws are tested under load under the conditions shown in Table Z101, pendulum systems, if any, being set at maximum.

Table Z101 - Test conditions for reciprocating saws

Orientation	Cutting a horizontal piece of chipboard 800 mm x 400 mm x 19 mm supported on resilient material and fixed to a bench
Tool bit/cutter/abrasive	New blade, as recommended by the manufacturer for cutting chipboard
Feed force	Just sufficient to cut at a brisk pace
Test cycle	Cutting off approximately 10 mm wide strips across the 400 mm width of the chipboard



7 Classification

This clause of Part 1 is applicable.

8 Marking and instructions

Ⓒ This clause of Part 1 is applicable except as follows:

8.12.2 a) Addition:

Z101) Information on the correct use of the dust collection system, if any

Z102) Advice to wear a dust mask Ⓒ

9 Protection against access to live parts

This clause of Part 1 is applicable.

10 Starting

This clause of Part 1 is applicable.

11 Input and current

This clause of Part 1 is applicable

12 Heating

This clause of Part 1 is applicable.

13 Leakage current

This clause of Part 1 is applicable.

14 Moisture resistance

This clause of Part 1 is applicable.

15 Electric strength

This clause of Part 1 is applicable.

16 Overload protection of transformers and associated circuits

This clause of Part 1 is applicable.

17 Endurance

This clause of Part 1 is applicable.

18 Abnormal operation

This clause of Part 1 is applicable.

19 Mechanical hazards

This clause of Part 1 is applicable except as follows:

19.1 Replacement:

a) For jigsaws

A barrier guard shall be provided to prevent inadvertent contact with the moving parts above the guide plate.

Compliance is checked by inspection and the following test.

The jigsaw is set for the right-angled cut. The test probe of Figure 101a) is positioned above the guide plate as shown in Figure 101b) and Figure 101c). The longitudinal axis of the test probe shall be perpendicular to the toothed edge of the saw blade. The test probe shall be equally shared about the central plane of the saw blade. When the test probe is moved towards the saw blade, it should not be able to touch its toothed edge.

b) For other types of reciprocating saws

A barrier guard shall be provided to prevent inadvertent contact with the moving parts.

Compliance is checked by inspection.

If a reciprocating saw is designed with a grip zone adjacent and behind the reciprocating saw blade, a barrier with a minimum height of 6 mm as measured from the grip surface shall be incorporated in line with the cutting edge of the blade. A barrier is not required if the tool is supplied with an auxiliary front handle.

20 Mechanical strength

This clause of Part 1 is applicable.

21 Construction

Ⓒ This clause of Part 1 is applicable except as follows:

21.Z1 This subclause of Part 1 is not applicable Ⓒ

22 Internal wiring

This clause of Part 1 is applicable.

23 Components

This clause of Part 1 is applicable.

24 Supply connection and external flexible cords

This clause of Part 1 is applicable.

25 Terminals for external conductors

This clause of Part 1 is applicable.

26 Provision for earthing

This clause of Part 1 is applicable.

27 Screws and connections

This clause of Part 1 is applicable.

28 Creepage distances, clearances and distances through insulation

This clause of Part 1 is applicable.

29 Resistance to heat, fire and tracking

This clause of Part 1 is applicable.

30 Resistance to rusting

This clause of Part 1 is applicable.

31 Radiation, toxicity and similar hazards

This clause of Part 1 is applicable.

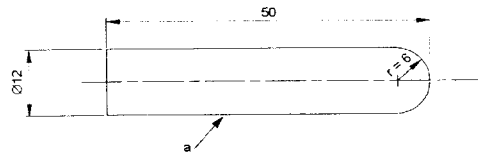

a) Details of test probe

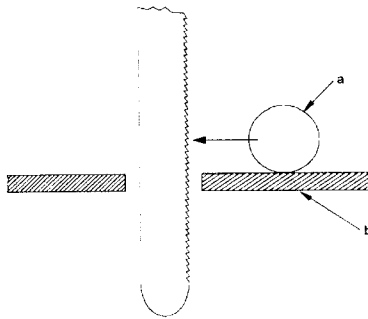

NOTE Upper structure of saw, which should prevent the test probe touching the saw blade, omitted for simplicity.

b) Side section showing position and direction of movement of test probe

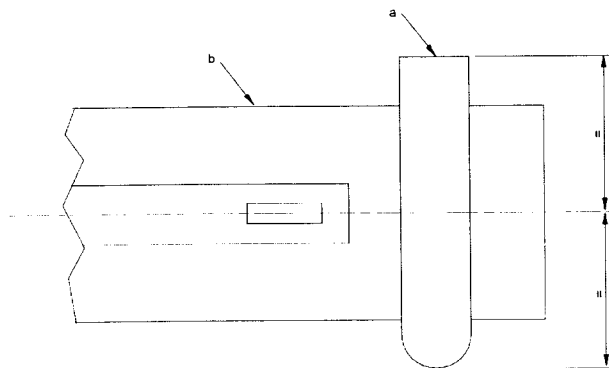

a = Test probe
b = Guide plate

NOTE Upper structure of saw omitted for simplicity.

c) Plan view of guide plate showing position of test probe

Figure 101 – Test probe

Annexes

The annexes of Part 1 are applicable except as follows.

Annex K (normative)

Battery tools and battery packs

K.1.1 Addition:

All clauses of this Part 2 apply unless otherwise specified in this annex.

Annex L (normative)

Battery tools and battery packs provided with mains connection or non-isolated sources

L.1.1 Addition:

All clauses of this Part 2 apply unless otherwise specified in this annex.

Bibliography

The bibliography of Part 1 is applicable.

BS EN
60745-2-11:
2003

BSI — British Standards Institution

BSI is the independent national body responsible for preparing British Standards. It presents the UK view on standards in Europe and at the international level. It is incorporated by Royal Charter.

Revisions

British Standards are updated by amendment or revision. Users of British Standards should make sure that they possess the latest amendments or editions.

It is the constant aim of BSI to improve the quality of our products and services. We would be grateful if anyone finding an inaccuracy or ambiguity while using this British Standard would inform the Secretary of the technical committee responsible, the identity of which can be found on the inside front cover. Tel: +44 (0)20 8996 9000. Fax: +44 (0)20 8996 7400.

BSI offers members an individual updating service called PLUS which ensures that subscribers automatically receive the latest editions of standards.

Buying standards

Orders for all BSI, international and foreign standards publications should be addressed to Customer Services. Tel: +44 (0)20 8996 9001. Fax: +44 (0)20 8996 7001. Email: orders@bsi-global.com. Standards are also available from the BSI website at <http://www.bsi-global.com>.

In response to orders for international standards, it is BSI policy to supply the BSI implementation of those that have been published as British Standards, unless otherwise requested.

Information on standards

BSI provides a wide range of information on national, European and international standards through its Library and its Technical Help to Exporters Service. Various BSI electronic information services are also available which give details on all its products and services. Contact the Information Centre. Tel: +44 (0)20 8996 7111. Fax: +44 (0)20 8996 7048. Email: info@bsi-global.com.

Subscribing members of BSI are kept up to date with standards developments and receive substantial discounts on the purchase price of standards. For details of these and other benefits contact Membership Administration. Tel: +44 (0)20 8996 7002. Fax: +44 (0)20 8996 7001. Email: membership@bsi-global.com.

Information regarding online access to British Standards via British Standards Online can be found at <http://www.bsi-global.com/bsonline>.

Further information about BSI is available on the BSI website at <http://www.bsi-global.com>.

Copyright

Copyright subsists in all BSI publications. BSI also holds the copyright, in the UK, of the publications of the international standardization bodies. Except as permitted under the Copyright, Designs and Patents Act 1988 no extract may be reproduced, stored in a retrieval system or transmitted in any form or by any means – electronic, photocopying, recording or otherwise – without prior written permission from BSI.

This does not preclude the free use, in the course of implementing the standard, of necessary details such as symbols, and size, type or grade designations. If these details are to be used for any other purpose than implementation then the prior written permission of BSI must be obtained.

Details and advice can be obtained from the Copyright & Licensing Manager. Tel: +44 (0)20 8996 7070. Fax: +44 (0)20 8996 7553. Email: copyright@bsi-global.com.

BSI
389 Chiswick High Road
London
W4 4AL