

UL 867

ISBN 0-7629-0475-5

# Electrostatic Air Cleaners



Underwriters Laboratories Inc. (UL)  
333 Pfingsten Road  
Northbrook, IL 60062-2096

UL Standard for Safety for Electrostatic Air Cleaners, UL 867

Fourth Edition, Dated October 9, 2000

Revisions: This Standard contains revisions through and including February 27, 2004.

### **Summary of Topics**

***This revision of UL 867 is being issued to include a revision to paragraph 11.1.5.2 per the 2002 National Electrical Code, and a revision to the column headings in Table 5.1.***

UL Standards for Safety are developed and maintained in the Standard Generalized Markup Language (SGML). SGML -- an international standard (ISO 8879-1986) -- is a descriptive markup language that describes a document's structure and purpose, rather than its physical appearance on a page. Due to formatting differences resulting from the use of UL's new electronic publishing system, please note that additional pages (on which no requirements have been changed) may be included in revision pages due to relocation of existing text and reformatting of the Standard.

Text that has been changed in any manner is marked with a vertical line in the margin. Changes in requirements are marked with a vertical line in the margin and are followed by an effective date note indicating the date of publication or the date on which the changed requirement becomes effective.

The new and/or revised requirements are substantially in accordance with UL's Bulletin(s) on this subject dated October 21, 2003. The bulletin(s) is now obsolete and may be discarded.

The revisions dated February 27, 2004 include a reprinted title page (page1) for this Standard.

As indicated on the title page (page 1), this UL Standard for Safety is an American National Standard. Attention is directed to the note on the title page of this Standard outlining the procedures to be followed to retain the approved text of this ANSI/UL Standard.

As indicated on the title page (page1), this UL Standard for Safety has been adopted by the Department of Defense.

The master for this Standard at UL's Northbrook Office is the official document insofar as it relates to a UL service and the compliance of a product with respect to the requirements for that product and service, or if there are questions regarding the accuracy of this Standard.

UL's Standards for Safety are copyrighted by UL. Neither a printed copy of a Standard, nor the distribution diskette for a Standard-on-Diskette and the file for the Standard on the distribution diskette should be altered in any way. All of UL's Standards and all copyrights, ownerships, and rights regarding those Standards shall remain the sole and exclusive property of UL.

All rights reserved. No part of this publication may be reproduced, stored in a retrieval system, or transmitted in any form by any means, electronic, mechanical photocopying, recording, or otherwise without prior permission of UL.

Revisions of UL Standards for Safety are issued from time to time. A UL Standard for Safety is current only if it incorporates the most recently adopted revisions.

UL provides this Standard "as is" without warranty of any kind, either expressed or implied, including but not limited to, the implied warranties of merchantability or fitness for any purpose.

In no event will UL be liable for any special, incidental, consequential, indirect or similar damages, including loss of profits, lost savings, loss of data, or any other damages arising out of the use of or the inability to use this Standard, even if UL or an authorized UL representative has been advised of the possibility of such damage. In no event shall UL's liability for any damage ever exceed the price paid for this Standard, regardless of the form of the claim.

UL will attempt to answer support requests concerning electronic versions of its Standards. However, this support service is offered on a reasonable efforts basis only, and UL may not be able to resolve every support request. UL supports the electronic versions of its Standards only if they are used under the conditions and operating systems for which it is intended. UL's support policies may change from time-to-time without notification.

UL reserves the right to change the format, presentation, file types and formats, delivery methods and formats, and the like of both its printed and electronic Standards without prior notice.

Purchasers of the electronic versions of UL's Standards for Safety agree to defend, indemnify, and hold UL harmless from and against any loss, expense, liability, damage, claim, or judgement (including reasonable attorney's fees) resulting from any error or deviation introduced while purchaser is storing an electronic Standard on the purchaser's computer system.

If a single-user version electronic Standard was purchased, one copy of this Standard may be stored on the hard disk of a single personal computer, or on a single LAN file-server or the permanent storage device of a multiple-user computer in such a manner that this Standard may only be accessed by one user at a time and for which there is no possibility of multiple concurrent access.

If a multiple-user version electronic Standard was purchased, one copy of the Standard may be stored on a single LAN file-server, or on the permanent storage device of a multiple-user computer, or on an Intranet server. The number of concurrent users shall not exceed the number of users authorized.

Electronic Standards are intended for on-line use, such as for viewing the requirements of a Standard, conducting a word search, and the like. Only one copy of the Standard may be printed from each single-user version of an electronic Standard. Only one copy of the Standard may be printed for each authorized user of a multiple-user version of an electronic Standard. Because of differences in the computer/software/printer setup used by UL and those of electronic Standards purchasers, the printed copy obtained by a purchaser may not look exactly like the on-line screen view or the printed Standard.

An employee of an organization purchasing a UL Standard can make a copy of the page or pages being viewed for their own fair and/or practical internal use.

The requirements in this Standard are now in effect, except for those paragraphs, sections, tables, figures, and/or other elements of the Standard having future effective dates as indicated in the note following the affected item. The prior text for requirements that have been revised and that have a future effective date are located after the Standard, and are preceded by a "SUPERSEDED REQUIREMENTS" notice.

New product submittals made prior to a specified future effective date will be judged under all of the requirements in this Standard including those requirements with a specified future effective date, unless the applicant specifically requests that the product be judged under the current requirements. However, if

the applicant elects this option, it should be noted that compliance with all the requirements in this Standard will be required as a condition of continued Listing, Recognition, and Follow-Up Services after the effective date, and understanding of this should be signified in writing.

Copyright © 2004 Underwriters Laboratories Inc.

This Standard consists of pages dated as shown in the following checklist:

Page	Date
1 .....	February 27, 2004
2-10 .....	October 9, 2000
11-12 .....	February 27, 2004
13-26 .....	October 9, 2000
27 .....	February 27, 2004
28-76 .....	October 9, 2000
A1-A2 .....	October 9, 2000

No Text on This Page

**OCTOBER 9, 2000**  
(Title Page Reprinted: February 27, 2004)



**ANSI/UL 867-2004**

1

**UL 867**

**Standard for Electrostatic Air Cleaners**

First Edition – December, 1980  
Second Edition – October, 1989  
Third Edition – March, 1995

**Fourth Edition**

**October 9, 2000**

The most recent designation of UL 867 as an American National Standard (ANSI) occurred on January 26, 2004. This ANSI/UL Standard for Safety, which consists of the Fourth Edition with revisions through February 27, 2004, is under continuous maintenance, whereby each revision is ANSI approved upon publication. Comments or proposals for revisions on any part of the Standard may be submitted to UL at any time. Written comments are to be sent to UL-SC Standards Department, 1655 Scott Blvd., Santa Clara, CA 95050.

The Department of Defense (DoD) has adopted UL 867 on June 11, 1992. The publication of revised pages or a new edition of this Standard will not invalidate the DoD adoption.

An effective date included as a note immediately following certain requirements is one established by Underwriters Laboratories Inc.

Revisions of this Standard will be made by issuing revised or additional pages bearing their date of issue. A UL Standard is current only if it incorporates the most recently adopted revisions, all of which are itemized on the transmittal notice that accompanies the latest set of revised requirements.

**ISBN 0-7629-0475-5**

**COPYRIGHT © 1980, 2004 UNDERWRITERS LABORATORIES INC.**

No Text on This Page



**CONTENTS**

<b>FOREWORD</b> .....	6
-----------------------	---

**INTRODUCTION**

1 Scope .....	7
2 General .....	7
2.1 Components .....	7
2.2 Units of measurement .....	8
2.3 Undated references .....	8
3 Glossary .....	8

**CONSTRUCTION**

4 General .....	9
5 Frame and Enclosure .....	9
5.1 General .....	9
5.2 High-voltage power supply .....	11
5.3 Stationary or fixed products .....	11
5.4 Portable products .....	14
6 Accessibility of Uninsulated Live Parts and Moving Parts .....	14
7 Mechanical Assembly .....	20
7.1 General .....	20
7.2 Assembly for shipping .....	21
8 Live Parts .....	21
9 Protection Against Corrosion .....	22
9.1 Enclosure intended for indoor use .....	22
9.2 Enclosure intended for outdoor use .....	22
10 Electrical Insulation .....	24
10.1 All circuits .....	24
10.2 Primary circuits .....	24
10.3 Secondary circuits .....	24
11 Supply Connections .....	25
11.1 Permanently-connected products .....	25
11.2 Cord-connected products .....	28
12 Polarization .....	31
13 Grounding .....	31
13.1 General .....	31
13.2 Bonding .....	32
13.3 Portable products .....	33
14 Internal Wiring .....	33
14.1 General .....	33
14.2 Primary circuits .....	34
14.3 High-voltage circuits .....	35
15 Capacitors .....	35
16 Coil Windings .....	35
17 Printed-Wiring Boards .....	36
18 Fuses and Fuseholders .....	36
19 Motors and Motor Overcurrent Protection .....	36
20 Washing .....	37
21 Filters .....	37

22	Spacings	37
22.1	General	37
22.2	Low voltage and isolated-limited-energy circuits	38
22.3	Line-voltage circuits	38
22.4	High-voltage circuits	41
22.5	Insulating barriers	42
23	Separation of Circuits	43
23.1	General	43
23.2	Class 2 circuits	44
23.3	Permanently-connected equipment	44

## PROTECTION AGAINST INJURY TO PERSONS

24	General	45
25	Rotating Parts	45
26	Enclosures and Guards	45
27	Impact Test	46
28	Switches and Interlocks	46
28.1	Switches	46
28.2	Interlocks	47
29	Stability	47
30	External Surface Temperatures	48

## PERFORMANCE

31	General	48
32	Leakage Current Test	49
32.1	General	49
32.2	Normal use	49
33	Leakage Current Following Humidity Conditioning	52
34	Partially Protected Parts	52
35	Input Test	53
36	Output Test	54
37	Ozone Test	54
38	Strain Relief Test	55
39	Pushback Relief Test	55
40	Grounding Resistance Test	55
41	Temperature Test	56
42	Dielectric Voltage-Withstand Test	61
42.1	General	61
42.2	High-voltage transformer core	62
42.3	Induced potential	62
43	Stored Energy Test	62
44	Evaluation of Reduced Spacings on Printed-Wiring Boards	64
44.1	General	64
44.2	Shorted trace test	64
45	Abnormal Operation Test	65
45.1	General	65
45.2	High-voltage supply	66
45.3	High-voltage spacings short circuit	66
45.4	Unenclosed high-voltage power supply	66
45.5	Component short- and open-circuit test	67
46	Metallic Coating Thickness Test	67

47 High-Voltage Insulating Material Arcing Test .....	.68
48 Permanence of Marking .....	.69

#### **MANUFACTURING AND PRODUCTION TESTS**

49 Dielectric Voltage-Withstand Test .....	.69
50 Grounding Continuity .....	.71

#### **RATINGS**

51 Details .....	.71
------------------	-----

#### **MARKINGS**

52 Visible During Installation and Inspection .....	.72
53 Visible After Installation .....	.73
54 Cautionary Markings .....	.74
55 Manufacturer's Literature .....	.74

#### **APPENDIX A**

Standards for Components.....	A1
-------------------------------	----

## FOREWORD

A. This Standard contains basic requirements for products covered by Underwriters Laboratories Inc. (UL) under its Follow-Up Service for this category within the limitations given below and in the Scope section of this Standard. These requirements are based upon sound engineering principles, research, records of tests and field experience, and an appreciation of the problems of manufacture, installation, and use derived from consultation with and information obtained from manufacturers, users, inspection authorities, and others having specialized experience. They are subject to revision as further experience and investigation may show is necessary or desirable.

B. The observance of the requirements of this Standard by a manufacturer is one of the conditions of the continued coverage of the manufacturer's product.

C. A product which complies with the text of this Standard will not necessarily be judged to comply with the Standard if, when examined and tested, it is found to have other features which impair the level of safety contemplated by these requirements.

D. A product employing materials or having forms of construction which conflict with specific requirements of the Standard cannot be judged to comply with the Standard. A product employing materials or having forms of construction not addressed by this Standard may be examined and tested according to the intent of the requirements and, if found to meet the intent of this Standard, may be judged to comply with the Standard.

E. UL, in performing its functions in accordance with its objectives, does not assume or undertake to discharge any responsibility of the manufacturer or any other party. The opinions and findings of UL represent its professional judgment given with due consideration to the necessary limitations of practical operation and state of the art at the time the Standard is processed. UL shall not be responsible to anyone for the use of or reliance upon this Standard by anyone. UL shall not incur any obligation or liability for damages, including consequential damages, arising out of or in connection with the use, interpretation of, or reliance upon this Standard.

F. Many tests required by the Standards of UL are inherently hazardous and adequate safeguards for personnel and property shall be employed in conducting such tests.

## INTRODUCTION

### 1 Scope

1.1 These requirements cover electrostatic air cleaners rated at 600 volts or less, intended to remove dust and other particles from the air and intended for use in accordance with the National Electrical Code, ANSI/NFPA 70.

1.2 These requirements do not cover electrostatic air cleaners for use in hazardous locations or to clean atmospheres defined as hazardous by the National Electrical Code, ANSI/NFPA 70.

1.3 These requirements do not cover air cleaners intended to remove particles other than dust and other particles normally found in heating and ventilating systems.

1.4 Requirements for the installation of duct-type electrostatic air cleaners are included in the Standards of the National Fire Protection Association for Installation of Air Conditioning and Ventilating Systems, NFPA 90A; and for Installation of Warm Air Heating and Air Conditioning Systems, NFPA 90B.

1.5 A product that contains features, characteristics, components, materials, or systems new or different from those covered by the requirements in this standard, and that involves a risk of fire or of electric shock or injury to persons shall be evaluated using appropriate additional component and end-product requirements to maintain the level of safety as originally anticipated by the intent of this standard. A product whose features, characteristics, components, materials, or systems conflict with specific requirements or provisions of this standard does not comply with this standard. Revision of requirements shall be proposed and adopted in conformance with the methods employed for development, revision, and implementation of this standard.

### 2 General

#### 2.1 Components

2.1.1 Except as indicated in 2.1.2, a component of a product covered by this standard shall comply with the requirements for that component. See Appendix A for a list of standards covering components used in the products covered by this standard.

2.1.2 A component is not required to comply with a specific requirement that:

- a) Involves a feature or characteristic not required in the application of the component in the product covered by this standard, or
- b) Is superseded by a requirement in this standard.

2.1.3 A component shall be used in accordance with its rating established for the intended conditions of use.

2.1.4 Specific components are incomplete in construction features or restricted in performance capabilities. Such components are intended for use only under limited conditions, such as certain temperatures not exceeding specified limits, and shall be used only under those specific conditions.

## 2.2 Units of measurement

2.2.1 Values stated without parentheses are the requirement. Values in parentheses are explanatory or approximate information.

## 2.3 Undated references

2.3.1 Any undated reference to a code or standard appearing in the requirements of this standard shall be interpreted as referring to the latest edition of that code or standard.

## 3 Glossary

3.1 For the purposes of this standard the following definitions apply.

3.2 ACCESSIBLE PART – A part located so that it can be contacted by a person either directly or by means of a probe as specified in Accessibility of Uninsulated Live Parts and Moving Parts, Section 6.

3.3 AIR CLEANERS – An air cleaner is defined as one of the following:

a) Duct type – A fixed or stationary type air cleaner intended for installation in and at adjoining ducts of heating, air conditioning, and ventilating systems. The air cleaner is not provided with a fan, and the duct may provide part or all of the overall enclosure.

b) Fixed type – A self-contained or duct type air cleaner intended to be permanently connected electrically.

c) Portable type – A cord-and-plug-connected, self-contained type air cleaner that:

- 1) Can be easily moved from one place to another for use and
- 2) Has no provision for permanent mounting.

d) Self-contained type – A fixed, portable, or stationary type air cleaner that includes all parts necessary for its intended operation, including active cell, fan, and the overall enclosure.

e) Stationary type – A cord-and plug-connected, self-contained or duct type air cleaner that is constructed to be fastened in place or located in a dedicated space.

3.4 ELECTROSTATIC AIR CLEANER (AIR CLEANER) – A product intended to remove dust and other particles from the air. The complete product consists of an assembly of a power pack, controls, ionizer-collector cell, and other components.

3.5 EXPOSED PART – A part that is subjected to handling in normal use without removing parts such as doors, covers, or other parts if removal requires the use of a tool.

3.6 HIGH-VOLTAGE CIRCUIT – A circuit involving a potential of more than 600 volts.

3.7 ISOLATED-LIMITED-ENERGY CIRCUIT – A circuit derived from an isolated-secondary winding of a transformer having a maximum capacity of 100 volt-amperes and an open-circuit-secondary voltage rating not exceeding 600 volts.

3.8 LINE-VOLTAGE CIRCUIT – A circuit involving a potential of not more than 600 volts, and having characteristics in excess of those of a low-voltage or an isolated-limited-energy circuit.

3.9 LOW-VOLTAGE CIRCUIT – A circuit involving a potential of not more than 30 volts rms and supplied by a primary battery, a Class 2 transformer, or by a combination of a transformer and fixed impedance that, as a unit, complies with all the performance requirements for a Class 2 transformer. A circuit derived from a line-voltage circuit by the connection of resistance in series with the supply circuit to limit the voltage and current is not considered to be a low-voltage or an isolated-secondary circuit.

3.10 PARTIALLY PROTECTED PART – A part that is exposed only during user servicing, with voltage and current limitations as specified in Partially Protected Parts, Section 34.

3.11 POWER SUPPLY – A unit consisting of a high-voltage transformer and other electrical component. The unit may also contain controls for the air cleaner.

3.12 USER SERVICING – The replacing, cleaning, or adjusting of filters or adjustment of controls and the like intended to be done by the user.

## **CONSTRUCTION**

### **4 General**

4.1 The construction of a product shall be such that all of the following conditions are met:

- a) Normal use and user servicing do not result in a risk of electric shock, fire, or injury to persons.
- b) The materials and component are used within their electrical, mechanical, and temperature limits.
- c) The assembly protects the components and wiring from being displaced or damaged.

### **5 Frame and Enclosure**

#### **5.1 General**

5.1.1 Electrical parts shall be provided with an enclosure.

5.1.2 Other than as noted in 5.1.3, an air-inlet or an air-outlet opening of a duct-type product may be considered enclosed by the adjacent duct work if an insulated or an uninsulated live part accessible without the duct work installed is at an energy level equal to or below that of a partially-protected part as specified in Partially Protected Parts, Section 34.

5.1.3 An air-inlet or an air-outlet opening not always intended to be attached to duct work is not considered to be enclosed.

5.1.4 The enclosure and parts of the enclosure such as doors, covers, and the like, shall be provided with means for securing them in place.

5.1.5 An enclosure or enclosure part shall be formed and assembled so that it will have the strength and rigidity necessary to resist the abuses to which it is likely to be subjected, without increasing its risk of fire, electric shock, or injury to persons due to total or partial collapse with resulting reduction of spacings, loosening or displacement of parts, or other serious defects.

5.1.6 A cast-metal or die-cast metal enclosure shall be investigated to determine that it is equivalent to sheet metal.

5.1.7 A nonmetallic enclosure shall be evaluated in accordance with the Standard for Polymeric Materials – Use In Electrical Equipment Evaluations, UL 746C.

5.1.8 Among the factors taken into consideration when evaluating the acceptability of a nonmetallic enclosure are:

- a) The mechanical strength,
- b) Resistance to impact,
- c) Moisture-absorptive properties,
- d) Combustibility, and
- e) Resistance to distortion at temperatures to which the material may be subjected under conditions of normal or abnormal usage.

5.1.9 Glass covering an observation opening shall be secured in place so that it cannot be readily displaced in service, and shall provide mechanical protection for the enclosed parts.

5.1.10 Glass for an opening not more than 4 inches (102 mm) in any dimension shall not be less than 0.055 inch (1.40 mm) thick. Glass for a larger opening, but not more than 144 square inches (929 cm<sup>2</sup>) in area and having no dimensions greater than 12 inches (305 mm), shall not be less than 0.115 inch (2.92 mm) thick.

5.1.11 Glass used to cover an opening larger than 144 square inches (929 cm<sup>2</sup>) shall be investigated to determine that it has the necessary mechanical strength and is otherwise suitable for the purpose.



**5.2 High-voltage power supply**

5.2.1 A high-voltage power supply shall be housed within its own enclosure or within a separate compartment of the main enclosure of the product or comply with the requirements specified in 45.4.1 – 45.5.1.

5.2.2 A power-supply enclosure shall be:

- a) Uncoated sheet steel not less than 0.026 inch (0.66 mm) thick;
- b) Zinc-coated sheet steel not less than 0.029 inch (0.74 mm) thick;
- c) Copper, brass, or aluminum not less than 0.036 inch (0.91 mm) thick; or
- d) A polymeric material complying with the applicable requirements in the Standard for Polymeric Materials – Use in Electrical Equipment Evaluations, UL 746C.

**5.3 Stationary or fixed products**

5.3.1 Other than as noted in 5.3.2, the thickness of a sheet-metal enclosure of a control panel, a duct door, or a similar component shall be as specified in Tables 5.1 and 5.2.

*Exception: Table 5.3 may be used for products that are only intended for ceiling mounting.*

**Table 5.1  
Minimum thickness of carbon steel or stainless steel enclosures**

Table 5.1 revised February 27, 2004

Without supporting frame <sup>a</sup>				With supporting frame or equivalent reinforcing <sup>a</sup>		Minimum thickness for uncoated,		Minimum thickness for coated,			
Maximum width, <sup>b</sup> inches	Maximum length, <sup>c</sup> (cm)	Maximum width, <sup>b</sup> inches	Maximum length, <sup>c</sup> (cm)	Maximum width, <sup>b</sup> inches	Maximum length, <sup>c</sup> (cm)	inch	(mm)	inch	(mm)		
4.0	10.2	Not limited		6.25	15.9	Not limited		0.020 <sup>d</sup>	0.51	0.023 <sup>d</sup>	0.58
4.75	12.1	5.75	14.6	6.75	17.1	8.25	21.0				
6.0	15.2	Not limited		9.5	24.1	Not limited		0.026 <sup>d</sup>	0.66	0.029 <sup>d</sup>	0.74
7.0	17.8	8.75	22.2	10.0	25.4	12.5	31.8				
8.0	20.3	Not limited		12.0	30.5	Not limited		0.032	0.81	0.034	0.86
9.0	22.9	11.5	29.2	13.0	33.0	16.0	40.6				
12.5	31.8	Not limited		19.5	49.5	Not limited		0.042	1.07	0.045	1.14
14.0	35.6	18.0	45.7	21.0	53.3	25.0	63.5				
18.0	45.7	Not limited		27.0	68.6	Not limited		0.053	1.35	0.056	1.42
20.0	50.8	25.0	63.5	29.0	73.7	36.0	91.4				
22.0	55.9	Not limited		33.0	83.8	Not limited		0.060	1.52	0.063	1.60
25.0	63.5	31.0	78.7	35.0	88.9	43.0	109.2				
25.0	63.5	Not limited		39.0	99.1	Not limited		0.067	1.70	0.070	1.78
29.0	73.7	36.0	91.4	41.0	104.1	51.0	129.5				
33.0	83.8	Not limited		51.0	129.5	Not limited		0.080	2.03	0.084	2.13
38.0	96.5	47.0	119.4	54.0	137.2	66.0	167.6				
42.0	106.7	Not limited		64.0	162.6	Not limited		0.093	2.36	0.097	2.46
47.0	119.4	59.0	149.9	68.0	172.7	84.0	213.4				
52.0	132.1	Not limited		80.0	203.2	Not limited		0.108	2.74	0.111	2.82

Table 5.1 Continued on Next Page

Table 5.1 Continued

Without supporting frame <sup>a</sup>		With supporting frame or equivalent reinforcing <sup>a</sup>		Minimum thickness for uncoated,		Minimum thickness for coated,					
Maximum width, <sup>b</sup> inches (cm)	Maximum length, <sup>c</sup> inches (cm)	Maximum width, <sup>b</sup> inches (cm)	Maximum length, <sup>c</sup> inches (cm)	inch (mm)	inch (mm)	inch (mm)	inch (mm)				
60.0	152.4	74.0	188.0	84.0	213.4	103.0	261.6	0.123	3.12	0.126	3.20
63.0	160.0	Not limited		97.0	246.4	Not limited					
73.0	185.4	90.0	228.6	103.0	261.6	127.0	322.6				

<sup>a</sup> See 5.3.4 and 5.3.5.

<sup>b</sup> The width is the smaller dimension of a rectangular sheet metal piece which is part of an enclosure. Adjacent surfaces of an enclosure may have supports in common and be made of a single sheet.

<sup>c</sup> For panels which are not supported along one side, for example, side panels of boxes, the length of the unsupported side shall be limited to the dimensions specified unless the side in question is provided with a flange at least 1/2 inch (12.7 mm) wide.

<sup>d</sup> Sheet metal for an enclosure intended for outdoor use – rainproof – shall not be less than 0.034 inch (0.86 mm) thick if zinc-coated and not less than 0.032 inch (0.81 mm) thick if uncoated.

**Table 5.2**  
**Thickness of sheet metal for enclosures of aluminum, copper, or brass**

Without supporting frame <sup>a</sup>		With supporting frame or equivalent reinforcing <sup>a</sup>		Minimum thickness,					
Maximum width, <sup>b</sup> inches (cm)	Maximum length, <sup>c</sup> inches (cm)	Maximum width, <sup>b</sup> inches (cm)	Maximum length, <sup>c</sup> inches (cm)	inch (mm)	inch (mm)				
3.0	7.6	Not limited		7.0	17.8	0.023 <sup>d</sup>	0.58		
3.5	8.9	4.0	10.2	8.5	21.6			9.5	24.1
4.0	10.2	Not limited		10.0	25.4			Not limited	
5.0	12.7	6.0	15.2	10.5	26.7	13.5	34.3	0.029	0.74
6.0	15.2	Not limited		14.0	35.6	Not limited		0.036	0.91
6.5	16.5	8.0	20.3	15.0	38.1	18.0	45.7		
8.0	20.3	Not limited		19.0	48.3	Not limited			
9.5	24.1	11.5	29.2	21.0	53.3	25.0	63.5	0.045	1.14
12.0	30.5	Not limited		28.0	71.1	Not limited		0.058	1.47
14.0	35.6	16.0	40.6	30.0	76.2	37.0	94.0		
18.0	45.7	Not limited		42.0	106.7	Not limited			
20.0	50.8	25.0	63.4	45.0	114.3	55.0	139.7	0.075	1.91
25.0	63.5	Not limited		60.0	152.4	Not limited		0.095	2.41
29.0	73.7	36.0	91.4	64.0	162.6	78.0	198.1		
37.0	94.0	Not limited		87.0	221.0	Not limited			
42.0	106.7	53.0	134.6	93.0	236.2	114.0	289.6	0.122	3.10
52.0	132.1	Not limited		123.0	312.4	Not limited		0.153	3.89
60.0	152.4	74.0	188.0	130.0	330.2	160.0	406.4		

<sup>a</sup> See 5.3.4 and 5.3.5.

<sup>b</sup> The width is the smaller dimension of a rectangular sheet metal piece which is part of an enclosure. Adjacent surfaces of an enclosure may have supports in common and be made of a single sheet.

<sup>c</sup> For panels which are not supported along one side, for example, side panels of boxes, the length of the unsupported side shall be limited to the dimensions specified unless the side in question is provided with a flange at least 1/2 inch (12.7 mm) wide.

<sup>d</sup> Sheet copper, brass, or aluminum for an enclosure intended for outdoor use – rainproof – shall not be less than 0.029 inch (0.74 mm) thick.

**Table 5.3**  
**Thickness of sheet metal for an enclosure of a ceiling-mounted product or an ionizer-collector frame assembly**

Maximum dimension, inches (mm)		Maximum area of any surface, feet <sup>2</sup> (m <sup>2</sup> )		Minimum thickness,											
				Steel						Copper, brass, or aluminum					
				Without supporting frame				With supporting frame or equivalent reinforcing				Without supporting frame,		With supporting frame or equivalent reinforcing,	
				Zinc coated,		Uncoated,		Zinc coated,		Uncoated,					
inch	(mm)	inch	(mm)	inch	(mm)	inch	(mm)	inch	(mm)	inch	(mm)	inch	(mm)		
60	1.5	10.42	0.97	0.034	0.86	0.032	0.81	0.029	0.74	0.026	0.66	0.045	0.66	0.036	0.91
	Over														
90	2.3	10.42	0.97	0.045	1.14	0.034	1.14	0.034	0.86	0.032	0.81	0.058	0.81	0.045	1.14
	Greater than														
90	2.3	10.42	0.97	0.056	1.42	0.053	1.35	0.045	1.14	0.042	1.07	0.075	1.07	0.058	1.47

5.3.2 A sheet-metal wall to which a wiring system is to be connected in the field shall have a thickness of not less than:

- a) 0.032 inch (0.81 mm) if uncoated steel,
- b) 0.034 inch (0.86 mm) if galvanized steel, or
- c) 0.045 inch (1.14 mm) if nonferrous.

5.3.3 Tables 5.1 and 5.2 are based on a uniform deflection of the enclosure surface for any given load concentrated at the center of the surface regardless of metal thickness.

5.3.4 With reference to Tables 5.1 – 5.3, a supporting frame is an angled structure, or channel, or a folded rigid section of sheet metal that is:

- a) Rigidly attached to the enclosure surface,
- b) Has essentially the same outside dimensions as the enclosure surface, and
- c) Has sufficient torsional rigidity to resist the bending moments that may be applied by the enclosure surface if it is deflected.

5.3.5 Equivalent reinforcing may be accomplished by constructions that will produce a structure as rigid as one that is built with a frame of angles or channels. Construction types without a supporting frame include:

- a) A single sheet with single formed flanges – formed edges;
- b) A single sheet that is corrugated or ribbed; or
- c) An enclosure surface loosely attached to a frame, for example, with spring clips.

5.3.6 The thickness of a sheet-steel enclosure of an ionizer-collector frame assembly shall be as specified in 5.3.2 and Table 5.3.

5.3.7 A duct-mounted product shall be provided with flanges that are acceptable for connection to a duct system on the air-inlet and air-outlet sides.

*Exception: In place of flanges, holes may be provided in the sides of the ionizer-collector frame assembly for the attachment of flanges or equivalent means to mount the product to the duct system.*

#### **5.4 Portable products**

5.4.1 A sheet-metal enclosure shall be evaluated with respect to its size, shape, thickness of metal, and its suitability for the application, considering the intended use of the complete air cleaner. The thickness of sheet steel shall not be less than 0.026 inch (0.66 mm) if uncoated or 0.030 inch (0.76 mm) if galvanized. Other sheet metal shall have a thickness not less than 0.036 inch (0.91 mm) except for small areas or for surfaces that are curved or otherwise reinforced.

5.4.2 A wooden enclosure shall not be less than 1/2 inch (12.7 mm) thick.

### **6 Accessibility of Uninsulated Live Parts and Moving Parts**

6.1 An opening in an enclosure shall comply with the following to reduce the likelihood of unintentional contact that may involve a risk of electric shock from an uninsulated live part or film-coated (magnet) wire, or injury to persons from a moving part:

- a) With regard to 6.5, for an opening that has a minor dimension less than 1 inch (25.4 mm), such a part or wire shall not be contacted by the probe illustrated in Figure 6.1.

*Exception: For a product only intended to be ceiling mounted, the probe illustrated in Figure 6.2 shall not contact moving part.*

- b) For an opening that has a minor dimension of 1 inch or more, such a part or wire shall be spaced from the opening as specified in Table 6.1.

*Exception: A motor need not comply with the requirements in (a) or (b) if it complies with the requirements in 6.2.*

Figure 6.1  
Articulate probe with web stop

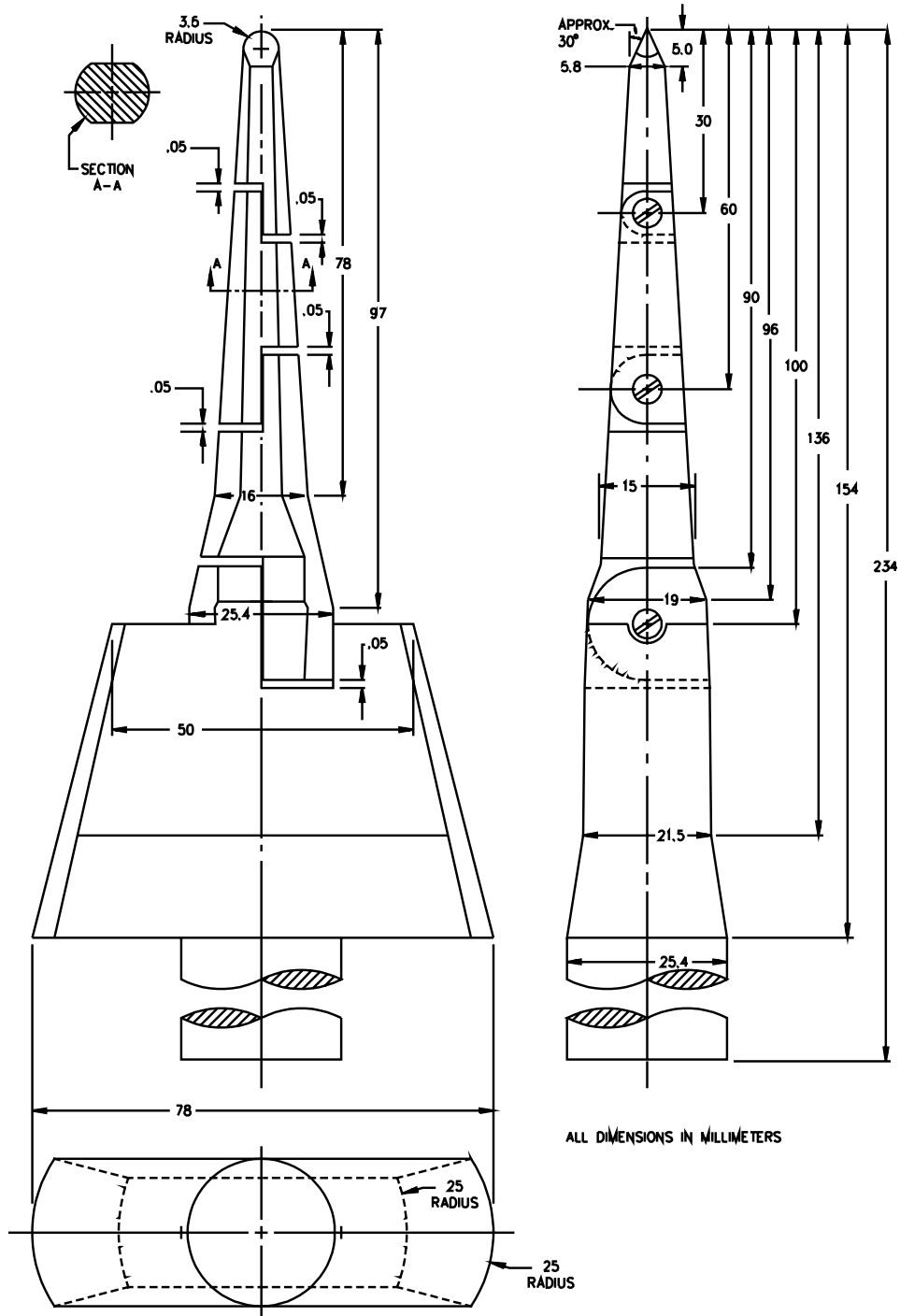

PA100A

**Figure 6.2**  
**Probe for moving parts of a ceiling mounted air cleaner**

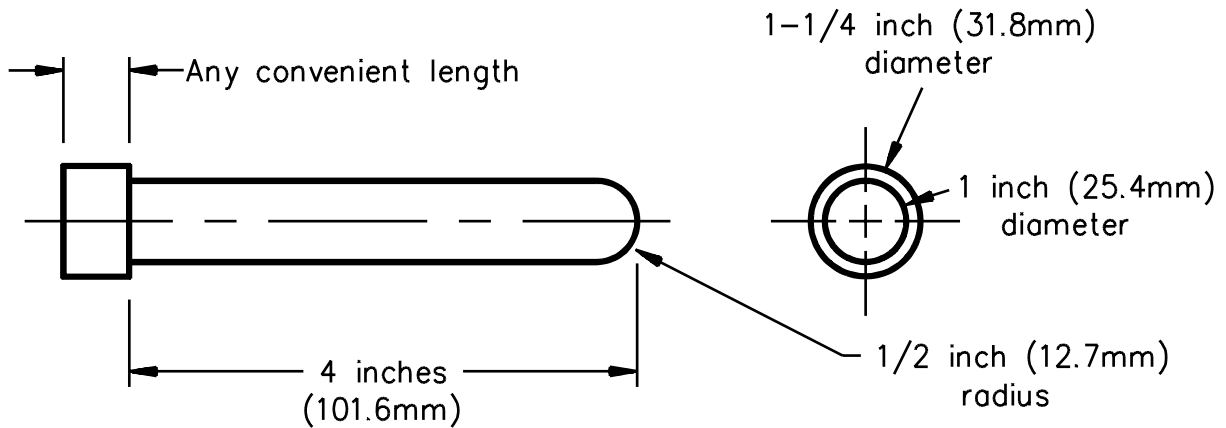

S2140

**Table 6.1**  
**Minimum distance from an opening to a part that may involve a risk of electric shock or injury to persons**

Minor dimension of opening, <sup>a,b</sup>		Minimum distance from opening to part <sup>b</sup> ,	
inches	(mm)	inches	(mm)
3/4 <sup>c</sup>	19.1	4-1/2	114.0
1 <sup>c</sup>	25.4	6-1/2	165.0
1-1/4	31.8	7-1/2	190.0
1-1/2	38.1	12-1/2	318.0
1-7/8	47.6	15-1/2	394.0
2-1/8	54.0	17-1/2	444.0
See footnote d		30	762.0

<sup>a</sup> See 6.5.  
<sup>b</sup> Between 3/4 and 2-1/8 inches, interpolation is to be used to determine a value between values specified in the table.  
<sup>c</sup> Any dimension less than 1 inch applies to a motor only.  
<sup>d</sup> More than 2-1/8 inches, but not more than 6 inches (152.0 mm).

6.2 Regarding a part or wire in an integral enclosure of a motor as mentioned in the Exception to 6.1:

a) An opening, as specified in 6.5, that has a minor dimension less than 3/4 inch (19.1 mm) may be used if:

- 1) A moving part cannot be contacted by the probe illustrated in Figure 6.3.

- 2) Film-coated (magnet) wire cannot be contacted by the probe illustrated in Figure 6.4.
  - 3) No uninsulated live part in a directly accessible motor, as described in 6.7, can be contacted by the probe illustrated in Figure 6.5.
  - 4) No uninsulated live part in an indirectly accessible motor, as described in 6.6, can be contacted by the probe illustrated in Figure 6.3.
- b) An opening that has a minor dimension of  $3/4$  inch or more may be used if a part or wire is spaced from the opening as specified in Table 6.1.

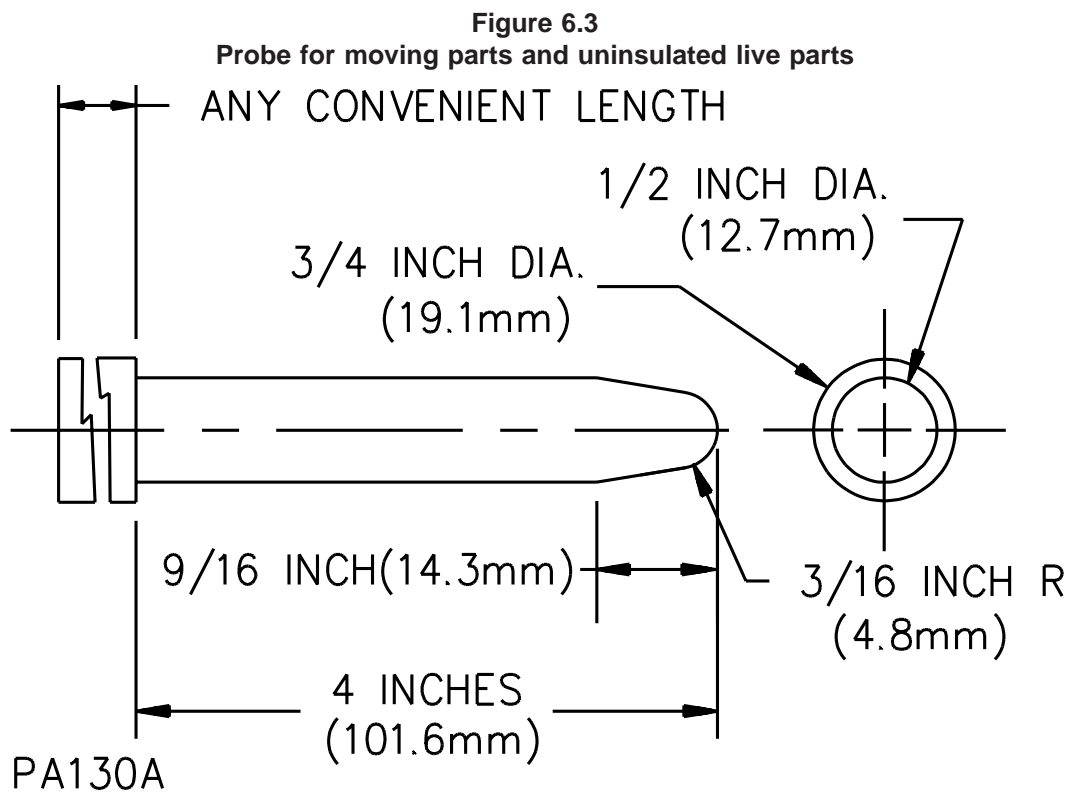
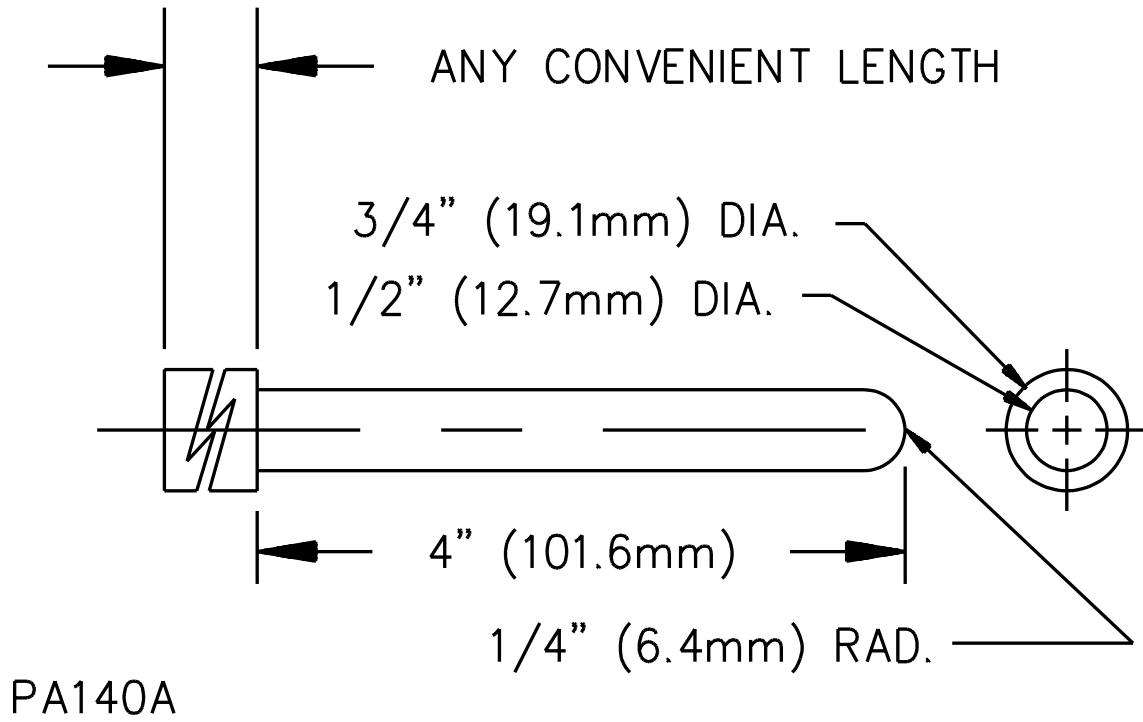
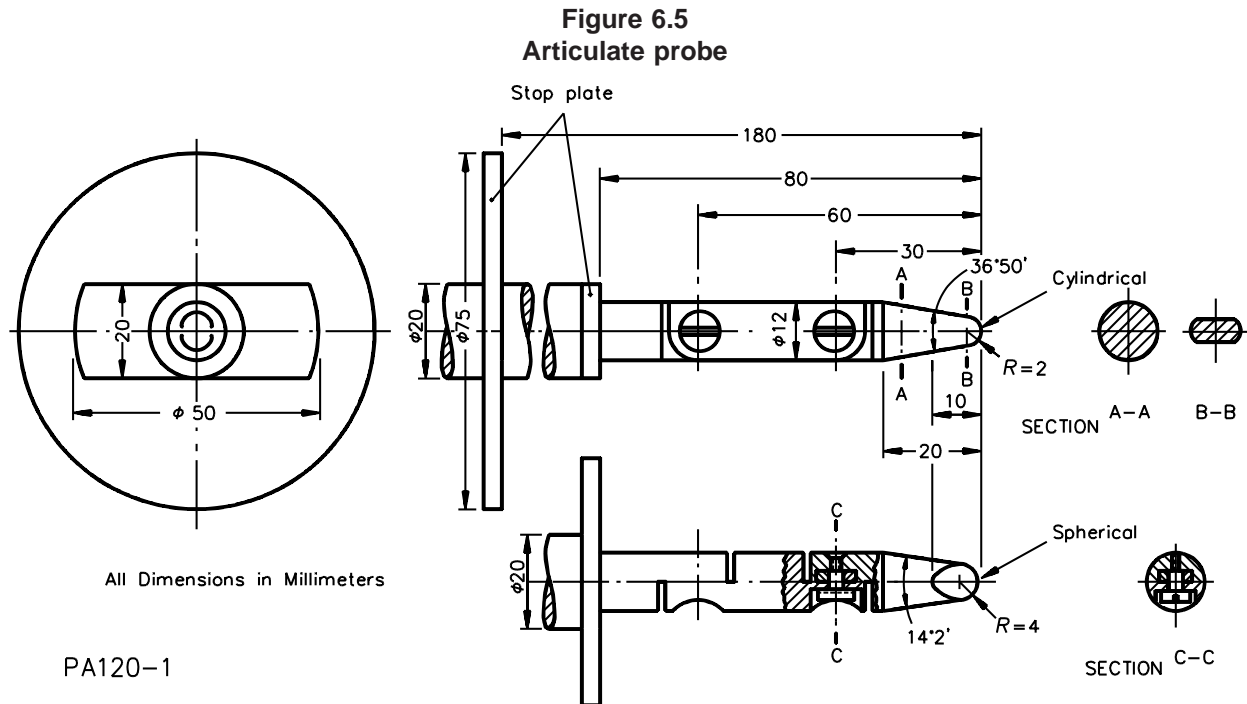

Figure 6.4  
Probe for film-coated (magnet) wire







6.3 The probes mentioned in 6.1 and 6.2 and illustrated in Figures 6.1 – 6.5 shall be applied to any depth that the opening will permit. They shall be rotated or angled before, during, and after insertion through the opening to any position that is necessary to examine the enclosure. The probes illustrated in Figures 6.1 and 6.5 shall be applied in any possible configuration. If necessary, the configuration shall be changed after insertion through the opening.

6.4 The probes mentioned in 6.3 and 6.5 are to be used as measuring instruments to evaluate the accessibility provided by an opening, and not as instruments to evaluate the strength of a material. They are to be applied with the minimum force necessary to determine accessibility.

6.5 With reference to the requirements in 6.1 and 6.2, the minor dimension of an opening is the diameter of the largest cylindrical probe having a hemispherical tip that can be inserted through the opening.

6.6 With reference to the requirements in 6.2, an indirectly accessible motor is a motor that is:

- a) Accessible only by opening or removing a part of the outer enclosure, such as a guard or panel, that can be opened or removed without using a tool or
- b) Located at such a height or is otherwise guarded or enclosed so that it is unlikely to be contacted.

6.7 A directly accessible motor is a motor that:

- a) Can be contacted without opening or removing any part or
- b) Is located so as to be accessible to contact.

6.8 During the examination of a product to determine whether it complies with the requirements in 6.1 or 6.2, a part of the enclosure that may be opened or removed by the user without using a tool (to attach an accessory, to make an operating adjustment, or for other reasons) is to be opened or removed.

6.9 With reference to the requirements in 6.1 and 6.2, insulated brush caps are not required to be additionally enclosed.

6.10 If the opening or removal of a door, a cover, or any other component required for user servicing permits access to a part that is considered to present a risk of electric shock (see 34.1), the door, cover, or component shall be provided with an interlock switch as specified in 28.2.1 – 28.2.5 to de-energize the primary circuit of the high-voltage power supply.

6.11 Unless a mechanical means is provided to discharge to ground any residual charge existing in the high-voltage parts after the primary circuit is de-energized, a time-delay feature shall be provided so that live parts do not become accessible until residual charges decay as required in 43.1.

## 7 Mechanical Assembly

### 7.1 General

7.1.1 A product shall be assembled so that it will not be adversely affected by the vibration of normal operation.

7.1.2 Provision shall be made for mounting a product securely. Bolts, screws, or other parts used for mounting the product shall be independent of those used for securing components of the product to the frame, base, or panel.

7.1.3 The mounting assembly shall be capable of supporting four times the weight of the product for 1 minute.

*Exception: A product that is intended to be mounted to a duct system need not comply with this requirement.*

7.1.4 A switch, a lampholder, an attachment-plug receptacle, a motor-attachment plug, or similar component shall be mounted securely and shall be prevented from turning.

*Exception No. 1: A switch need not be prevented from turning if all four of the following conditions are met:*

- a) The switch is of a plunger or other type that does not tend to rotate. A toggle switch is considered to be subjected to forces that turn the switch during its normal operation.*
- b) It is unlikely that the operation of the switch will loosen its mounting means.*
- c) Spacings are not reduced below the minimum values if the switch rotates.*
- d) Normal operation of the switch is by mechanical means rather than by direct contact by persons.*

*Exception No. 2: A lampholder of the type in which the lamp cannot be replaced, such as for a neon pilot or indicator light in which the lamp is sealed by a nonremovable jewel, need not be prevented from turning if rotation cannot reduce the spacings below the minimum required values.*

7.1.5 Means for preventing the turning mentioned in 7.1.4 is to consist of more than friction between surfaces. For instance, a properly applied lock washer can be used as a means to prevent a small stem-mounted switch or other device having a single-hole mounting means from turning.

7.1.6 If a vertically-mounted switch or circuit breaker is such that movement of the operating handle results in one position being above the other position, the upper position shall be the on position.

*Exception: This requirement does not apply to horizontally- or rotationally-mounted switches, or switching devices with more than one on position, such as a double-throw or timer switch.*

## **7.2 Assembly for shipping**

7.2.1 A product shall be completely assembled when it is shipped from the factory.

*Exception: A product may be shipped partially disassembled to facilitate packing or installation if the intended assembly can be accomplished readily without introduction of risk of fire, electric shock, or injury to persons.*

7.2.2 If mismatching of components of a product that is shipped disassembled presents a risk of fire, electric shock, or injury to persons, the parts shall be marked as specified in 52.2. See also 7.2.4.

7.2.3 If a cord-connected product is shipped partially disassembled, internal connections that must be made in the field shall be made by plug and receptacle connections. If a product intended for permanent connection to the power supply is shipped partially disassembled, internal connections that must be made in the field shall be made in accordance with 11.1.1.1 – 11.1.5.5 or by plug and receptacle connections.

7.2.4 A product that is shipped from the factory partially disassembled shall be shipped in a single shipping container or marked in accordance with 52.2.

## **8 Live Parts**

8.1 A current-carrying part shall have the necessary mechanical strength and ampacity, and shall be made of a metal that can be used for the application.

8.2 An uninsulated live part shall be secured to its supporting surface by a means other than friction between surfaces so that it will be prevented from turning or shifting in position if such motion may result in a reduction of spacings below the minimum required values. The construction of a contact assembly shall be such that the alignment of the contacts will be maintained.

## 9 Protection Against Corrosion

### 9.1 Enclosure intended for indoor use

9.1.1 Iron and steel parts shall be protected against corrosion by enameling, galvanizing, sherardizing, plating, or other means that have been determined to be equivalent.

*Exception No. 1: Small minor parts of iron or steel such as washers, screws, bolts, and the like that do not carry current.*

*Exception No. 2: Parts made of stainless steel are not required to be additionally protected against corrosion.*

*Exception No. 3: Bearings and other parts for which protection is impractical because of the function of the part.*

9.1.2 The requirement in 9.1.1 applies to all parts of the framework and enclosure; all iron and steel current-carrying parts, except resistors; all spring-door fasteners; and other parts upon which proper mechanical operation may depend.

9.1.3 Iron and steel used within an enclosure that is intended to be washed down during normal maintenance of the air cleaner shall be protected against corrosion. A zinc coating that withstands, without a fixed deposit, three 1-minute dips in a standard copper sulphate solution, or some other coating that has been determined to be equivalent, may be used. Painting or baked enamel is not considered to provide the required protection.

9.1.4 Bonderized steel parts provided with a primer coat and covered by a baked-alkyd-enamel finish are considered to comply with the requirements in 9.1.3.

### 9.2 Enclosure intended for outdoor use

9.2.1 A sheet-steel enclosure intended for outdoor use shall be protected against corrosion by one of the following coatings:

- a) Hot-dipped, mill-galvanized sheet steel complying to the coating Designation G90 in Table I of the Specification for General Requirements for Sheet Steel, Zinc-Coated (Galvanized) by the Hot-Dip Process, ASTM A525-87, with not less than 40 percent of the zinc on any side, based on the minimum single-spot test requirement in this ASTM designation. See 9.2.5.
- b) A zinc coating, other than that provided on hot-dipped, mill-galvanized sheet steel, uniformly applied to an average thickness of not less than 0.00061 inch (0.015 mm) on each surface with a minimum thickness of 0.00054 inch (0.014 mm). An annealed coating shall comply with 9.2.2 and 9.2.3.
- c) A zinc coating complying with (1) or (2) and with one coat of an organic finish of the epoxy or alkyd-resin type or other outdoor paint on both surfaces. If necessary, the acceptability of the paint may be determined by evaluation of its composition or by corrosion tests.

- 1) Hot-dipped, mill-galvanized sheet steel complying with the coating Designation G60 or A60 in Table I of the Specifications for General Requirements for Sheet Steel, Zinc-Coated (Galvanized) by the Hot-Dip Process, ASTM A525-87, with not less than 40

percent of the zinc on any side, based on the minimum single-spot test requirement in this ASTM designation. See 9.2.4. An A60 (alloyed) coating shall also comply with 9.2.2 and 9.2.3.

2) A zinc coating, other than that provided on hot-dipped, mill-galvanized sheet steel, uniformly applied to an average thickness of not less than 0.00041 inch (0.010 mm) on each surface with a minimum thickness of 0.00034 inch (0.009 mm). An annealed coating shall also comply with 9.2.2 and 9.2.3. See 9.2.6.

d) A cadmium coating not less than 0.0010 inch (0.025 mm) thick on both surfaces. See 9.2.6.

e) A cadmium coating not less than 0.00075 inch (0.019 mm) thick on both surfaces with one coat of outdoor paint on both surfaces, or not less than 0.00051 inch (0.013 mm) thick on both surfaces with two coats of outdoor paint on both surfaces. The paint shall be as described in (c). See 9.2.6.

f) Other finishes, including paints, metal finishes, or combinations of the two may be used when comparative tests with galvanized sheet steel (without annealing, wiping, or other surface treatment) complying with (a), indicate they provide equivalent protection. Among the factors that are taken into consideration when judging such coating systems are exposure to salt spray, moist carbon dioxide-sulphur dioxide-air mixture, moist hydrogen sulphide-air mixtures, ultraviolet light, and water.

9.2.2 A hot-dipped, mill-galvanized A60-alloyed-coating or an annealed coating on sheet steel that is bent or similarly formed or extruded or rolled at the edge of a hole after annealing shall be additionally painted in the affected area if the process damages the zinc coating.

9.2.3 If flaking or cracking of the zinc coating at the outside radius of the bent or formed section is visible at 25-power magnification, the zinc coating is considered to be damaged.

9.2.4 Simple sheared or cut edges and punched holes are not required to be additionally protected.

9.2.5 The weight of the zinc coating referred to in 9.2.1 (a) and (c)(1) may be determined by any method that has been determined to be acceptable; however, in case of question the weight of coating shall be established in accordance with the Tests for Weight of Coating on Zinc-Coated (Galvanized) Iron or Steel Articles, ASTM A90-81.

9.2.6 The thickness of the cadmium or zinc coating mentioned in 9.2.1 (b), (c)(2), (d), and (e) shall be established by the Metallic Coating Thickness Test, Section 46.

## **10 Electrical Insulation**

### **10.1 All circuits**

10.1.1 A thermoplastic or epoxy potting compound shall be used within its temperature rating and shall be a minimum of 1/32 inch (0.8 mm) thick. Prior to potting, the parts shall be mechanically secure.

10.1.2 An epoxy potting compound used for reduced spacings shall be used as indicated in Exception No. 1 to 22.3.1 and Exception No. 4 to 22.4.1.

10.1.3 A thermoplastic potting compound used for reduced spacings shall be used as indicated in Exception No. 1 to 22.3.1 and Exception No. 8 to 22.4.1.

### **10.2 Primary circuits**

10.2.1 A base for the support of a live part shall be glazed slate, porcelain, phenolic, cold-molded composition, or other material that has been evaluated for such use. It shall be able to withstand the most severe conditions likely to be met in service.

10.2.2 Insulating material, including barriers between parts of opposite polarity and material that may be subject to the influence of the arc formed by opening of a switch, shall be evaluated for the application.

10.2.3 Vulcanized fiber may be used for insulating bushings, washers, separators, and barriers, but shall not be used for the sole support for uninsulated live parts of other than low-voltage circuits.

### **10.3 Secondary circuits**

10.3.1 A base for the support of a high-voltage part shall be of glazed porcelain, mica, glass, or other insulating material that has been evaluated for the application. It shall be moisture resistant and constructed so that, considering the material use, it will withstand the most severe conditions likely to be met in service.

10.3.2 Insulating materials, including barriers between uninsulated high-voltage parts of opposite polarity and between uninsulated high-voltage parts and grounded metal that may be subjected to arcing, shall be evaluated for the application. See 22.5.1.

10.3.3 Insulating materials other than those specified in 10.3.1 and 10.3.2 may be used based on the results of the High-Voltage Insulating Material Arcing Test, Section 47.

## 11 Supply Connections

### 11.1 Permanently-connected products

#### 11.1.1 General

11.1.1.1 A product shall have provision for the connection of a wiring system.

11.1.1.2 A product shall be provided with wiring terminals or leads for the connection of conductors having an ampacity rated for the sum of the following:

- a) The ampere rating of the power pack and
- b) One hundred twenty-five percent of the full-load motor current.

11.1.1.3 It is assumed that a product will be connected with conductors having 60°C (140°F) insulation unless otherwise marked.

11.1.1.4 A lead that is intended to be spliced in the field to a branch-circuit conductor shall not be smaller than No. 18 AWG (0.82 mm<sup>2</sup>) and the insulation, if rubber or thermoplastic, shall not be less than 1/32 inch (0.79 mm) thick.

#### 11.1.2 Wiring compartment

11.1.2.1 A terminal box or compartment for making power-supply connections in the field shall be of ample size to accommodate such connections and shall be located so that the connections can be readily inspected after the product is installed as intended.

11.1.2.2 If inspection indicates that the volume of a compartment may be insufficient to accommodate the intended wiring, a trial installation is to be made using wires of the size specified in 11.1.1.2 and conduit and fitting sized for the wire in accordance with the National Electrical Code, ANSI/NFPA 70.

#### 11.1.3 Conduit connection means

11.1.3.1 A tapped hole for the attachment of threaded rigid conduit shall be provided with:

- a) At least three full threads tapped all the way through the wall of an enclosure and located so that a bushing may be attached to the end of the conduit or
- b) At least 3-1/2 full threads and a smooth, rounded inlet hole having a diameter approximately the same as the internal diameter of a standard bushing to provide protection for the conductors equivalent to that provided by such a bushing.

11.1.3.2 A knockout in a sheet-metal enclosure shall be reliably secured but shall be capable of being removed without undue deformation of the enclosure.

11.1.3.3 A plate or plug used to close an unused conduit opening or other hole in the enclosure shall be securely mounted and shall have:

- a) For an opening with a 1/4 inch (6.4 mm) or smaller maximum dimension, a thickness not less than 0.014 in (0.36 mm) for steel nor less than 0.019 inch (0.48 mm) for nonferrous metal.
- b) For an opening with a maximum dimension greater than 1/4 inch, but not greater than 1-3/8 inches (34.9 mm), a thickness not less than 0.027 inch (0.69 mm) for steel nor less than 0.032 inch (0.81 mm) for nonferrous metal.
- c) For an opening with a maximum dimension greater than 1-3/8 inches, a thickness equal to that required for the enclosure of the device or equal to that required for a standard knockout seal.

11.1.3.4 A flat surface shall be provided around all knockouts, and the location of the knockouts shall be such that the spacing between the installed conduit bushing and uninsulated live parts will not be less than the minimum values specified in Spacings, Section 22.

11.1.3.5 When measuring a spacing between an uninsulated live part and a bushing installed in the knockout referred to in 11.1.3.4, it is to be assumed that a bushing having the dimensions specified in Table 11.1 is in place, in conjunction with a single locknut.

**Table 11.1**  
**Dimensions of bushings**

Trade size of conduit, inches	Overall diameter,		Height,	
	inches	(mm)	inches	(mm)
1/2	1	25.4	3/8	9.5
3/4	1-15/64	31.4	27/64	10.7
1	1-19/32	40.5	33/64	13.1
1-1/4	1-15/16	49.2	9/16	14.3
1-1/2	2-13/64	56.0	19/32	15.1
2	2-45/64	68.5	5/8	15.9
2-1/2	3-7/32	81.8	3/4	19.1
3	3-7/8	98.4	13/16	20.6
3-1/2	4-7/16	113.1	15/16	23.8
4	4-31/32	126.6	1	25.4
4-1/2	5-35/64	141.0	1-1/16	27.0
5	6-7/32	158.0	1-3/16	30.2
6	7-7/32	183.4	1-1/4	31.8



#### 11.1.4 Terminal parts

11.1.4.1 A field-wiring terminal shall be provided with a pressure terminal connector, firmly bolted or held by a screw.

*Exception: A wire-binding screw may be employed at a field-wiring terminal intended to accommodate a No. 10 AWG (5.3 mm<sup>2</sup>) or smaller conductor if upturned lugs or the equivalent are provided to hold the wire in position.*

11.1.4.2 A wire-binding screw to which field-wiring connections are made shall not be smaller than No. 8 (4.2 mm diameter).

*Exception: A No. 6 (3.5 mm diameter) screw may be used at a terminal intended only for the connection of a No. 14 AWG (2.1 mm<sup>2</sup>) conductor.*

11.1.4.3 A terminal plate tapped for a wire-binding screw shall be of metal not less than 0.030 inch (0.76 mm) thick for a No. 14 AWG (2.1 mm<sup>2</sup>) or smaller wire and not less than 0.050 inch (1.27 mm) thick for a wire larger than No. 14 AWG.

11.1.4.4 A terminal plate tapped for a wire-binding screw shall be provided with no fewer than two full threads in the metal. The metal may be extruded at the tapped hole for the binding screw to provide two full threads.

*Exception: Two full threads are not required if fewer threads result in a secure connection in which the threads will not strip upon the application of a 20 pound-inch (2.26 N·m) tightening torque.*

11.1.4.5 A wire-binding screw shall thread into metal.

#### 11.1.5 Terminal identification

11.1.5.1 A permanently connected product rated 125 or 125/250 volts (three-wire) or less employing a screw-shell lampholder, a single-pole switch, or a single-pole overcurrent-protective device other than an automatic control without a marked off position, shall have one terminal or lead identified for the connection of the grounded conductor of the supply circuit.

11.1.5.2 A field-wiring terminal intended for the connection of a grounded supply conductor shall be identified by means of a metallic coating that is substantially white in color. It shall be readily distinguishable from the other terminals, or proper identification of the terminal for the connection of the grounded conductor shall be clearly shown in some other manner, such as on a wiring diagram provided on the product. If wire leads are provided instead of terminals, the lead intended to be connected to the grounded supply conductor shall have a white or gray color and shall be readily distinguishable from the other leads.

11.1.5.2 revised February 27, 2004

11.1.5.3 The surface of an insulated lead intended for the connection of an equipment-grounding conductor shall be green with or without one or more yellow stripes. No other lead shall be so identified.

*Exception: A conductor with insulation having a surface that is green or green with or without one or more yellow stripes may be used for internal wiring provided such wiring does not serve as a lead wire for connection to branch-circuit conductors.*

11.1.5.4 A wire-binding screw intended for the connection of an equipment-grounding conductor shall have a green-colored head that is hexagonal, slotted, or both. It shall be located so that it is unlikely to be removed during normal servicing of the product.

11.1.5.5 A pressure wire connector intended for connection of an equipment-grounding conductor shall be plainly identified, such as by being marked "G," "GR," "Ground," "Grounding," or the like, or by a marking on a wiring diagram provided on the product. The pressure wire connector shall be located so that is unlikely to be removed during normal servicing of the product.

## 11.2 Cord-connected products

### 11.2.1 Cords and plugs

11.2.1.1 A cord-connected product shall be provided with a flexible cord that is not less than 6 feet (1.83 m) nor more than 10 feet (3.05 m) long. The cord shall be provided with an attachment plug for connection to the supply circuit.

*Exception: A power-supply cord provided with a duct- or plenum-mounted product shall not be more than 6 feet long.*

11.2.1.2 To allow for maintenance and repair, a duct- or plenum-mounted product may be provided with a power-supply cord if:

- a) The cord is:
  - 1) A 3-conductor Type SJT or heavier duty cord rated for at least 105°C (221°F) and
  - 2) Terminated in a grounding attachment plug;
- b) The product is intended to obtain its power supply from a furnace, a field-wiring compartment containing a single receptacle for plug connection of the product is packaged with the product for installation on the furnace;
- c) Installation instructions in accordance with 55.5 are provided; and
- d) The mounting means is constructed so that it permits ready removal, such as keyhole slots, if the integrity of the duct or plenum is not reduced as a result of such removal.

11.2.1.3 The flexible cord shall include a grounding conductor.

*Exception: This requirement does not apply to a product complying with the requirements in the Exception to 13.1.1.*

11.2.1.4 A flexible cord that includes a grounding conductor shall be provided with a grounding-type attachment plug. A flexible cord that does not include a grounding conductor shall be provided with a 2-blade polarized attachment plug.

11.2.1.5 The flexible cord shall be Type SP-2, SPE-2, SPT-2, or of a type that has been evaluated for harder service.

11.2.1.6 The voltage rating of the cord and the attachment plug shall not be less than the rated voltage of the product.

11.2.1.7 The ampacity of the cord and the current rating of the fittings for a product rated at 15 amperes or less shall not be less than that of the product. For a product rated more than 15 amperes, the ampacity of the cord shall not be less than the current rating of the product. The current rating of the attachment plug shall not be less than 125 percent of the current rating of the product, except that a 20-ampere plug can be used for a product rated not more than 4,000 watts at 240 volts.

11.2.1.8 The flexible cord may be attached permanently to the product, or may be in the form of a separate cord set with means for connection to the product.

11.2.1.9 A product intended for use with a cord set shall not be provided with terminal pins that will accommodate a standard flatiron or appliance plug.

#### 11.2.2 Strain relief

11.2.2.1 A product shall be provided with means to prevent stress on the power-supply cord from being transmitted to terminals, splices, or wiring within the product. The product shall comply with the Strain Relief Test, Section 38.

11.2.2.2 A metal strain-relief clamp or band (without auxiliary protection) may be used with a Type S, SE, SJ, SJE, SJO, SJT, SJTO, SO, ST, or STO cord. A metal strain-relief clamp or band may be used with Type SP-2 rubber-insulated cord and with Type SPT-2 cord only if auxiliary, nonconducting, mechanical protection is provided with the cord and the combination is determined acceptable by investigation.

11.2.2.3 Means shall be provided so that the flexible cord or supply leads cannot be pushed into the product through the cord-entry hole when such displacement results in:

- a) Mechanical damage to the cord or leads;
- b) Exposure of the cord or leads to a temperature higher than that for which it is rated; or
- c) A reduction of spacings, such as to a metal strain-relief attachment, below the minimum required values.

To determine compliance with this criteria, the cord shall be subjected to the Pushback Relief Test, Section 39.

11.2.2.4 If a knot in a flexible cord serves as strain relief, any surface that the knot can touch shall be free from burrs, fins, projections, sharp edges, and the like that may abrade the cord.

### 11.2.3 Bushings

11.2.3.1 A bushing or the equivalent shall be provided at an opening in a wall, barrier, or enclosure through which a supply cord passes. The bushing or the equivalent shall be substantial, reliably secured in place, and shall have a smooth, rounded surface against which the cord may bear. If a cord other than Type S, SE, SJ, SJE, SJO, SJT, SJTO, SO, ST, or STO is employed and the wall or barrier is of metal, an insulating bushing shall be provided.

11.2.3.2 In general, ceramic materials and some molded compositions may be used for insulating bushings.

11.2.3.3 A separate neoprene or polyvinyl chloride bushing may be employed on a supply cord:

a) Anywhere in a product if it is used in conjunction with a type of cord for which an insulating bushing is not required or

b) Where the cord enters the frame of a motor or the enclosure of a capacitor that is physically attached to a motor if:

1) The bushing is not less than 3/64 inch (1.2 mm) thick and

2) The bushing is located so that it will not be exposed to oil, grease, oil vapor, or other substances that can have a deleterious effect on the compound employed.

11.2.3.4 The edges of the hole in which a neoprene or polyvinyl chloride bushing is used shall be free from burrs, fins, and the like that are capable of damaging the bushing.

11.2.3.5 A bushing of the same material as, and molded integrally with, the supply cord may be used with a Type SP-2 or heavier cord if the built-up section is not less than 3/64 inch (1.2 mm) thick at the point at which the cord passes through the enclosure.

11.2.3.6 An insulated metal grommet may be used in place of an insulating bushing if the insulating material used is not thinner than 1/32 inch (0.8 mm) and completely fills the space between the grommet and the metal in which the grommet is mounted.

## 12 Polarization

12.1 The screw shell of each lampholder shall be connected:

- a) To the conductor or terminal intended to be connected to the grounded conductor of the supply circuit, for a permanently-connected product;
- b) To the conductor of the supply cord intended to be connected to the grounded conductor of the supply circuit, for a cord-connected product; or
- c) To the same supply conductor in the absence of a conductor or terminal intended to be connected to the grounded conductor of the supply circuit.

12.2 A fuseholder, a single-pole switch, an overcurrent-protective device, and an automatic control with a marked off position shall be connected to an ungrounded conductor of the supply circuit.

12.3 The screw shell of a plug-type fuseholder and the accessible contact of an extractor-type fuseholder shall be connected toward the load.

## 13 Grounding

### 13.1 General

13.1.1 Each product shall be provided with a means for grounding.

*Exception: A portable product that is rated less than 150 volts need not have provision for grounding.*

13.1.2 If a grounding means is provided on a product, all exposed dead metal parts that are likely to become energized and all dead metal parts within the enclosure that are exposed to contact during any user-servicing operation and that are likely to become energized shall be reliably connected to the grounding means.

*Exception: An ungrounded high-voltage transformer core need not comply with this requirement if it withstands the dielectric voltage-withstand test specified in 42.2.1.*

13.1.3 With reference to the requirement in 13.1.2, the following dead metal parts are not considered likely to become energized:

- a) A small metal part (such as an adhesive-attached foil marking, a screw, a handle, or the like) that is:
  - 1) On the exterior of the enclosure and separated from all components by grounded metal or
  - 2) Electrically isolated from all electrical components.
- b) A panel or cover that is insulated from all electrical components by a barrier of vulcanized fiber, varnished cloth, phenolic composition, or other moisture-resistant insulating material not less than 1/32 inch (0.8 mm) thick and reliably secured in place.
- c) A panel or cover that does not enclose uninsulated live parts or is electrically isolated from other electrical components.

d) Cores and assembly screws of relays, solenoids, and the like.

13.1.4 Upon insertion of a removable part, the grounding connection shall be made before the electrical connection, and, upon removal, the grounding connection shall be broken after the electrical connection.

## 13.2 Bonding

13.2.1 Unless the dead-metal parts described in 13.1.2 are bonded together by mechanical fasteners, a separate bonding conductor or strap shall be used for this purpose.

13.2.2 The bonding shall be by positive means, such as clamping, riveting, bolted or screwed connections, brazing, or welding. The bonding connection shall penetrate a nonconductive coating. Bonding around a resilient mounting shall not depend on the clamping action of rubber or similar material unless the construction has been shown by investigation to be acceptable for the purpose. This investigation may include such tests as overload, short-circuit, and aging.

13.2.3 The bonding conductor shall be of a material and size that has been evaluated for use as an electrical conductor. It shall be protected from corrosion unless inherently corrosion resistant. A bonding conductor or strap shall be installed so that it is protected from mechanical damage.

13.2.4 The size of an electrical conductor or strap employed to bond an electrical enclosure or motor frame shall be determined by the rating of the overcurrent-protective device of the branch circuit to which the product will be connected in accordance with the National Electrical Code, ANSI/NFPA 70.

*Exception No. 1: A conductor smaller than that specified may be used if the bonding connection does not open when carrying current equal to twice the rating of the branch-circuit overcurrent device for 2 minutes.*

*Exception No. 2: A bonding connector to a motor need not be larger than the motor-circuit conductors.*

13.2.5 If more than one size branch-circuit overcurrent device is involved, the size of the bonding conductor is to be based on the rating of the overcurrent device intended to provide ground-fault protection for the component bonded by the conductor. For example, if a motor may be individually protected by a branch-circuit overcurrent device smaller than the overcurrent devices protecting the overall product, the size of a bonding conductor for that motor is to be selected on the basis of the overcurrent device intended for the ground-fault protection of the motor.

### 13.3 Portable products

13.3.1 If a flexible cord with a grounding conductor is provided, the grounding conductor shall be:

- a) Green with or without one or more yellow stripes;
- b) Connected to the grounding blade of a grounding attachment plug; and
- c) Connected to the frame or enclosure of the product by means of a screw not likely to be removed during ordinary servicing, or by other reliable means. Solder alone shall not be used to make this connection.

## 14 Internal Wiring

### 14.1 General

14.1.1 Internal wiring and connections shall be protected or enclosed to reduce the likelihood of stress on the connections or damage to the insulation.

14.1.2 A bare conductor, including pigtail and coil leads, shall be supported so that at least the minimum required spacings will be maintained.

14.1.3 Each splice and connection shall be mechanically secure and shall be arranged so that stress on the connections and terminals does not result.

14.1.4 A splice shall be provided with insulation if permanence of spacing between the splice and other metal parts cannot be maintained.

14.1.5 A wireway shall be smooth and free from sharp edges, burrs, fins, moving parts, and the like, that may abrade wire insulation.

14.1.6 An aluminum conductor, insulated or uninsulated, used as internal wiring, such as for interconnection between current-carrying parts or as motor winding, shall be terminated at each end by a method that has been evaluated for the combination of metals involved at the connection point.

14.1.7 If a wire-binding screw or a pressure wire connector is used as a terminating device for an aluminum conductor, it shall be for use with aluminum under the conditions involved (for example, temperature, heat cycling, and vibration).

14.1.8 A nominal 0.110-, 0.125-, 0.187-, 0.205-, or 0.250-inch wide quick-connect terminal shall comply with the Standard for Electrical Quick-Connect Terminals, UL 310. Other sizes of quick-connect terminals shall be investigated with respect to crimp pull-out, engagement-disengagement forces of the connector and tab, and temperature rises. All tests shall be conducted in accordance with UL 310.

## 14.2 Primary circuits

14.2.1 The internal wiring of a product shall consist of general-use wire or appliance-wiring material that has been determined to be acceptable for the application, when considered with respect to the temperature, voltage, and condition of service to which the wiring is likely to be subjected.

14.2.2 Regarding 14.2.1, wiring material of one or more of the types specified in Table 14.1 having insulation thickness not less than that specified in Table 14.1 may be used for internal wiring.

*Exception: Wiring material having insulation thinner than specified in Table 14.1 may be used if the insulation, when considered with respect to the temperature, voltage, and conditions of service, is considered equivalent to the thickness specified in Table 14.1.*

**Table 14.1**  
**Appliance-wiring materials**

Type of insulation	Nominal thickness of insulation, inch (mm) <sup>a</sup>							
	600-volt applications				300-volt applications			
	With an impregnated-braid cover,		Without a braid cover,		With an impregnated-braid cover,		Without a braid cover,	
	inch	(mm)	inch	(mm)	inch	(mm)	inch	(mm)
Thermoplastic	–	–	1/32	0.8	–	–	1/32 <sup>b</sup>	0.8 <sup>b</sup>
Rubber	1/32	0.8	–	–	1/64	0.4	1/32	0.8
	plus cover thickness				plus cover thickness			
Neoprene	–	–	3/64	1.2	1/64	0.4	1/32	0.8
	plus cover thickness				plus cover thickness			
Silicone rubber	1/32	0.8	1/32 <sup>c</sup>	0.8 <sup>c</sup>	1/64	0.4	1/32 <sup>c</sup>	0.8 <sup>c</sup>
	plus cover thickness				plus cover thickness			

<sup>a</sup> The minimum thickness is 0.028 inch (0.71 mm) for 1/32-inch- (0.8-mm-) thick insulation; the minimum thickness is 0.013 inch (0.33 mm) for 1/64-inch- (0.4-mm-) thick insulation.

<sup>b</sup> A minimum of 1/64 inch (0.4 mm) thick only for short, moving pigtails, or coil leads in a small device, if such leads make no more than casual contact with parts of opposite polarity and with grounded parts.

<sup>c</sup> Only if routed away from live parts of opposite polarity and protected from mechanical damage both during installation of field wiring and while in operation, unless material has the necessary resistance to mechanical damage.

14.2.3 Holes in a sheet-metal wall through which insulated wires pass shall be provided with a bushing.

*Exception: Smooth-edged holes in walls thicker than 0.042 inch (1.07 mm), need not comply with this requirement.*



### **14.3 High-voltage circuits**

14.3.1 Internal secondary wiring shall be general-use high-voltage wire or wiring material rated for the application. The voltage rating of the wire shall not be less than the maximum peak voltage measured between the wire and any other part.

14.3.2 A hole in a metal partition through which an ungrounded lead or ungrounded terminal passes shall have smooth, well-rounded edges or shall be provided with a bushing. If the bushing deforms the wire insulation, the bushing shall be subjected to the High-Voltage Insulating Arcing Test, Section 47.

14.3.3 A bushing of glazed porcelain, steatite, or that which has been determined to be the equivalent may be used for secondary leads and terminals.

14.3.4 A bushing of phenolic composition may be used if the voltage involved is less than 1000 volts.

14.3.5 Bushings other than those specified in 14.3.3 and 14.3.4 may be used based on results of the High-Voltage Insulating Materials Arcing Test, Section 47.

### **15 Capacitors**

15.1 The materials and construction of a capacitor and its enclosure shall reduce the risk of emission of flame from the enclosure of the product in the event of malfunction of the capacitor.

15.2 The materials and construction of a capacitor or its enclosure within a product shall reduce the risk of developing pressures in the capacitor capable of causing injury to persons in the event of malfunction of the capacitor or the circuit in which it is connected.

### **16 Coil Windings**

16.1 Windings of a motor, relay, transformer, and the like shall resist the absorption of moisture.

16.2 With regard to the requirement in 16.1, film-coated (magnet) wire is not required to be additionally treated to resist absorption of moisture, but fiber slot liners, cloth coil wrap, and similar moisture-absorptive materials shall be impregnated or otherwise treated to resist moisture absorption.

## 17 Printed-Wiring Boards

17.1 A printed-wiring board shall comply with the Standard for Printed-Wiring Boards, UL 796, and shall be classed V-0, V-1, or V-2 in accordance with the requirements in the Standard for Tests for Flammability of Plastic Materials for Parts in Devices and Appliances, UL 94.

17.2 A resistor, a capacitor, an inductor, or other part that is mounted on a printed-wiring board to form a printed-circuit assembly shall be secured so that it cannot be displaced by a force likely to be exerted on it during assembly, intended operation, or servicing.

17.3 With regard to 17.2, a barrier or a partition that is part of the air cleaner assembly may be used to provide mechanical protection.

## 18 Fuses and Fuseholders

18.1 A fuse and a fuseholder shall have voltage and current ratings that are for use in the circuit in which they are connected. A fuseholder shall be suitable for use with a cartridge fuse.

*Exception: A plug fuse may be used in a circuit rated 125 volts or 125/250 volts, 3-wire, or less.*

## 19 Motors and Motor Overcurrent Protection

19.1 A motor shall be evaluated for the application and shall be capable of driving the maximum normal load of the product without introducing a risk of fire, electric shock, or injury to persons.

19.2 A brush-holder assembly shall be constructed so that when the brush is no longer capable of performing its function, the brush, spring, and other parts of the assembly are retained to the degree necessary not to cause:

- a) Accessible dead metal parts to become energized and
- b) Live parts to become accessible.

19.3 Each motor shall be provided with at least one of the following:

- a) Thermal protection complying with the applicable requirements in the Standard for Overheating Protection for Motors, UL 2111.

*Exception: A motor intended to move air only by means of an air-moving fan that is integrally attached, keyed, or otherwise fixed to the motor shaft is not required to have running overload protection.*

- b) Impedance protection complying with the applicable requirements in the Standard for Motor-Operated Appliances, UL 73, when the motor is tested as used in the product under locked-rotor conditions.
- c) Other protection that is shown by tests to be equivalent to the protection mentioned in (a).

19.4 Motor-overload protection provided for a product not required to have such protection shall:

- a) Comply with the requirements in 19.3.
- b) Be shown by test not to result in a risk of fire, electric shock, or injury to persons.

## 20 Washing

20.1 A duct-type product provided with fixed means for washing the ionizer-collector frame assembly shall comply with the following:

- a) The circuitry of a product having provision for automatic or manual washing means shall be interlocked so that the power pack will be de-energized while the system is being washed.
- b) The primary circuit of a product shall be interlocked so that the blower-fan motor is de-energized while the system is being washed.

20.2 A duct-type product having fixed means for automatically or manually applying adhesive to the ionizer-collector frame assembly shall have the circuitry interlocked so that the power pack and blower-fan motor are de-energized while adhesive is being applied.

## 21 Filters

21.1 An air-cleaner filter shall comply with the requirements for Class 1 or Class 2 air filters as specified in the Standard for Air Filter Units, UL 900.

*Exception: A filter within a portable product need not comply with this requirement if the filter is not located near wiring, a collector-ionizer cell, or other components where ignition is likely to occur.*

21.2 A filter utilizing adhesive or other materials shall be equivalent to a Class 1 or Class 2 filter.

## 22 Spacings

### 22.1 General

22.1.1 All uninsulated live parts connected to different line- or low-voltage circuits shall be spaced from one another as though they were parts of opposite polarity and shall be evaluated on the basis of the highest voltage involved.

22.1.2 The spacing at a field-wiring terminal is to be measured with wire of the size appropriate for the rating connected to the terminal as in actual service.

22.1.3 Wiring terminals are considered to be terminals to which connections are made in the field.

22.1.4 The spacings in a component device, such as a snap switch, a lampholder, a motor, and the like supplied as part of an air cleaner shall not be less than the minimum spacings required for the component device or the spacings specified in Table 22.1, whichever are smaller.

**Table 22.1**  
**Spacings in line-voltage circuits**

Location involved	Voltage, AC	Minimum spacings			
		Through air,		Over surface,	
		inch	(mm)	inch	(mm)
Between field-wiring terminals of opposite polarity	0 – 150	1/4	6.4	1/4	6.4
	151 – 300	1/4	6.4	3/8	9.5
	301 – 600	3/8	9.5	1/2	12.7
Between uninsulated live parts of opposite polarity or between an uninsulated live part and a grounded part other than the enclosure <sup>a</sup>	0 – 50	1/16	1.6	1/16	1.6 <sup>b</sup>
	51 – 150	1/8	3.2	1/4	6.4 <sup>b</sup>
	151 – 300	1/4	6.4	3/8	9.5 <sup>b</sup>
	301 – 600	3/8	9.5	1/2	12.7
Between an uninsulated live part and the walls of the metal enclosure, or other accessible dead metal part, including fittings for conduit or armored cable <sup>c</sup>	0 – 600	1/2	12.7	1/2	12.7

<sup>a</sup> In a portable product using a fractional horsepower motor rated 300 volts or less, the spacing through air or over surface may be 3/32 inch (2.4 mm) minimum; and if the motor rating does not exceed either 1/3 horsepower (250 watts output) or 150 volts, the spacings may be 1/16 inch minimum.

<sup>b</sup> For printed-wiring boards, see Exception Nos. 1 – 3 to 22.3.1.

<sup>c</sup> A metal piece attached to the enclosure is considered to be a part of the enclosure if deformation of the enclosure is likely to reduce spacings between the metal piece and uninsulated live parts.

22.1.5 Regarding spacing requirements, film-coated (magnet) wire is considered to be an uninsulated live part.

## 22.2 Low voltage and isolated-limited-energy circuits

22.2.1 Spacings between components of low-voltage and isolated-limited-energy circuits are not specified.

## 22.3 Line-voltage circuits

22.3.1 The spacings in a line-voltage circuit shall comply with Table 22.1.

*Exception No. 1: Minimum 1/32 inch (0.8 mm) through air and over surface spacings before potting for parts that are potted in an insulating compound may be applied. A thermoplastic potting compound is to be evaluated with regard to its acceptability for the application. If an investigation is necessary to determine if a material may be used, such investigation is to be conducted in accordance with the Standard for Polymeric Materials – Use in Electrical Equipment Evaluations, UL 746C. Consideration is to be given to:*

- a) The mechanical strength of the material, resistance to hot wire ignition, resistance to high-current-arc ignition, resistance to high-voltage-arc ignition, dielectric strength, insulation resistance, and heat-resistant qualities, in both the aged and unaged conditions;*
- b) The degree to which the material is enclosed; and*
- c) Any other feature affecting the risk of fire, electric shock, electrical high-energy current levels, or injury to persons.*

*All factors are to be considered with regard to conditions of actual service.*

*Exception No. 2: On a printed-wiring board, the over surface spacing may be reduced to 1/32 inch (0.8 mm) if the board is coated with a conformal coating complying with the Standard for Polymeric Materials-Use in Electrical Equipment Evaluations, UL 746C.*

*Exception No. 3: On a printed wiring board, spacing requirements (other than for spacings to ground, between different circuits, and at field wiring terminals) may be waived between traces of different potentials connected in the same circuit if:*

- a) The spacings comply with the Evaluation of Reduced Spacings on Printed-Wiring Boards, Section 44;*
- b) The printed-wiring board has a flammability classification of V-0, in accordance with the requirements in the Standard for Tests for Flammability of Plastic Materials for Parts in Devices and Appliances, UL 94; and*
- c) The printed wiring board is constructed from a base material having a minimum Comparative Tracking Index (CTI) Performance Level Category rating of 2 in accordance with the Standard for Polymeric Materials – Use in Electrical Equipment Evaluations, UL 746C.*

22.3.2 An insulating barrier or liner used as the separation (with or without an air spacing) between uninsulated live parts and grounded dead-metal parts, including the enclosure, or between uninsulated live parts of opposite polarity, shall be of a material that has been determined to be acceptable for the mounting of uninsulated live parts. The material shall not be less than 0.028 inch (0.71 mm) thick.

*Exception No. 1: Insulating material less than 0.028 inch thick may be used if it has been investigated and determined to be acceptable for the application.*

*Exception No. 2: A barrier or liner that is used with not less than one-half the required spacing through air may be less than 0.028 inch (0.71 mm) but not less than 0.013 inch (0.33 mm) thick if the barrier or liner is of a material that:*

- a) Has been investigated and determined to be acceptable for the mounting of an uninsulated live part,*
- b) Is of the necessary mechanical strength if exposed or otherwise likely to be subjected to mechanical damage,*
- c) Is reliably held in place, and*
- d) Is located so that it will not be adversely affected by operation of the equipment in service.*

22.3.3 When used in conjunction with a minimum 1/32-inch (0.79-mm) air spacing, fiber not less than 0.028 inch (0.71 mm) thick may be used:

- a) As the sole separation between the enclosure and an uninsulated part electrically connected to a grounded-circuit conductor, or
- b) For an uninsulated live part.

22.3.4 Insulation between a crossover lead and the turns of the winding to which it is connected, the adjacent winding, the metallic enclosure, and the core, shall be one of the following:

- a) Electrical grade paper, waxed or otherwise treated to resist the absorption of moisture, having a total thickness not less than 0.013 inch (0.33 mm).
- b) Other insulating material mechanically and thermally equivalent to that of (a) having a dielectric breakdown strength of 2500 volts or more in the thickness used.

*Exception No. 1: The spacings specified in Table 22.1 may be provided in lieu of insulation.*

*Exception No. 2: Any type and thickness of insulation, or a through air spacing, between a crossover lead and the winding to which it is connected may be used if either:*

- a) The insulation withstands the dielectric voltage-withstand test potential described in 42.1.1(a) with the potential applied between the coil leads and with the coil lead cut at the point where it enters the inner layer or*
- b) The insulation withstands the induced-potential test described in 42.3.1 – 42.3.3.*

*Exception No. 3: This requirement does not apply to insulation between a Class 2 secondary crossover lead and:*

- a) The secondary winding to which the crossover lead is connected,*
- b) The metallic enclosure, and*
- c) The core.*

22.3.5 A slot in a molded bobbin for guiding the crossover or start lead (unspliced at the windings) of a magnet-coil may be used as crossover-lead insulation if:

- a) The slot provides a graduated through air spacing to the winding, increasing to the end turns, and
- b) The magnet-coil winding withstands the induced potential test described in 42.3.1 – 42.3.3.

## 22.4 High-voltage circuits

22.4.1 Spacings between an insulated or uninsulated high-voltage part and:

- a) Insulated or uninsulated line-voltage circuit parts,
- b) Other high-voltage parts of opposite polarity, and
- c) Dead metal

shall comply with Table 22.2.

*Exception No. 1: The spacings specified in Table 22.2 for insulated and uninsulated high-voltage parts to dead metal, other than the enclosure, may be waived if:*

- a) The high-voltage power supply performs without risk of fire or electric shock during the short-circuit test described in 45.3.1.*
- b) The high-voltage part insulation complies with the High-Voltage Insulating Material Arcing Test, Section 47.*

*Exception No. 2: The spacing requirements in Table 22.2 may be waived between:*

- a) High-voltage parts of opposite polarity and*
- b) High-voltage parts and dead metal parts (other than the enclosure)*

*that have current levels acceptable for a partially protected part as determined by the spacing withstanding the dielectric voltage withstand potentials specified in the Dielectric Voltage-Withstand Test, Section 42.*

*Exception No. 3: The spacing requirements in Table 22.2 may be waived if a barrier or liner, as described in 22.5.1, is used.*

*Exception No. 4: The spacing requirements in Table 22.2 may be waived if epoxy potting compounds or conformal coatings, as described in Exception Nos. 1 and 2 to 22.3.1, respectively, are used.*

*Exception No. 5: On a printed wiring board, the spacing requirements in Table 22.2 may be waived between traces of different potentials located in the same high-voltage circuit if:*

- a) The product complies with the requirements of Evaluation of Reduced Spacings on Printed Wiring Boards, Section 44;*
- b) The printed wiring board has a flammability classification of V-0 in accordance with the requirements in the Standard for Tests for Flammability of Plastic Materials for Parts in Devices and Appliances, UL 94; and*
- c) The printed wiring board has a minimum Comparative Tracking Index (CTI) Performance Level Category rating of 1 in accordance with the Standard for Polymeric Materials – Use in Electrical Equipment Evaluations, UL 746C.*

*Exception No. 6: Table 22.2 does not specify requirements for spacings between the filter cell plates.*

*Exception No. 7: High-voltage wiring need not comply with Table 22.2.*

*Exception No. 8: Minimum 1/32 inch (0.8 mm) through air and over surface spacings is required before potting for parts that are potted in a thermoplastic insulating compound that complies with 10.3.3.*

**Table 22.2**  
**Spacings for high-voltage parts**

Voltage involved	Minimum spacings through air and over surfaces					
	Between uninsulated high-voltage parts				Between insulated high-voltage parts in the powerpack and filter cell, <sup>a</sup>	
	Power pack,		Filter cell, <sup>a</sup>			
inches	(mm)	inches	(mm)	inches	(mm)	
601 – 3000	3/4	19.0	1	25.4	1/2	12.7
3001 – 5000	1	25.4	1	25.4	1/2	12.7
5001 – 10,000	1-1/8	28.6	1	25.4	3/4	19.0
10,001 – 15,000	1-1/2	38.1	1	25.4	1	25.4
15,001 – 20,000	1-3/4	44.5	1-1/4	31.8	1-1/4	31.8
20,001 – 25,000	2	50.8	1-1/2	38.1	1-1/2	38.1

<sup>a</sup> Spacings within the active filter area may be less to permit proper functioning of the filter.

22.4.2 If a secondary terminal is provided with an insulating cap, the spacing to the live part of the terminal is to be measured through the crevice where the surface of the cap abuts the remainder of the insulator.

## 22.5 Insulating barriers

22.5.1 With regard to Exception No. 3 to 22.4.1, a barrier or liner shall be constructed to withstand the most severe condition anticipated in service. It shall:

- a) Have the necessary mechanical strength if exposed or otherwise subjected to mechanical damage and
- b) Be reliably held in place.

Typical materials that may be used are specified in Table 22.3.



**Table 22.3**  
**Insulating barriers for high-voltage circuits**

Materials	Minimum thickness,	
	inch	(mm)
Phenolic composition <sup>a</sup>	1/32	0.8
Cold-molded composition <sup>a</sup>	3/32	2.4
Porcelain, unglazed <sup>a,b</sup>	1/8	3.2
Porcelain, glazed	1/8	3.2
Mica	1/32	0.8
Glass	1/8	3.2

<sup>a</sup> May be used only when tested as described in the High-Voltage Insulating Material Arcing Test, Section 47.  
<sup>b</sup> Unglazed porcelain tubes may be used for insulated wires.

## 23 Separation of Circuits

### 23.1 General

23.1.1 Unless provided with insulation rated for the highest voltage involved, factory-installed insulated conductors of different circuits shall be spaced as specified in Table 22.2, or separated by barriers. In any case, the conductors shall be segregated (see 23.1.2) from uninsulated live parts of a different circuit.

23.1.2 Segregation of insulated conductors may be accomplished by clamping, routing, or means that have been determined to be equivalent to maintain separation from insulated or uninsulated live parts of a different circuit.

23.1.3 A metal barrier used to provide segregation shall be:

- a) Grounded,
- b) Of the necessary strength and rigidity, and
- c) At least the thickness specified in Tables 5.1 and 5.2 where noted under the columns titled "With supporting frame or equivalent reinforcing" for the dimensions of the barrier.

A barrier of insulating material shall be of such thickness and be supported so that its deformation cannot be readily accomplished so as to defeat its purpose. In any case, the thickness shall not be less than 0.028 inch (0.72 mm). A barrier between uninsulated live parts connected to different circuits, and a barrier between uninsulated live parts of one circuit and the wiring of another circuit shall also comply with the requirements in 22.3.3 and 22.3.4.

## 23.2 Class 2 circuits

23.2.1 The output of a transformer supplying a Class 2, low-voltage circuit and provided as a part of the equipment shall not be interconnected with the output of another such transformer. Each transformer shall be treated as a separate circuit, with each having its own separate wiring compartment. The output of each circuit shall be marked to warn that the separation shall be maintained.

*Exception: The output of two or more transformers supplying a Class 2, low-voltage circuit provided as part of the equipment may be interconnected if the voltage and current measurements at the output terminals are within the values for a single Class 2, 30-volt, or less, transformer.*

## 23.3 Permanently-connected equipment

23.3.1 The equipment shall be constructed so that a field-installed conductor of any circuit shall be segregated (see 23.3.2) or separated by barriers (see 23.1.3) from:

- a) Factory-installed conductors connected to any other circuit, unless the conductors of both circuits will be insulated for the maximum voltage of either circuit;
- b) Uninsulated live parts of any other circuit of the device; and
- c) Field-installed conductors connected to any other circuit.

*Exception: Field-installed conductors may contact low-voltage wiring terminals if short-circuiting to such terminals will not result in a risk of fire or electric shock.*

23.3.2 Segregation of field-installed conductors from other field-installed or factory-installed conductors and from uninsulated live parts of the product connected to different circuits may be accomplished by arranging the location of the openings in the enclosure for the various conductors, with respect to the terminals or other uninsulated live parts, so that a minimum separation of 1/4 inch (6.4 mm) can be maintained.

23.3.3 It is to be assumed, for the purpose of determining compliance with 23.3.1, that the conductors entering each opening of the enclosure will be connected to the terminals opposite the opening if:

- a) The number of openings in the enclosure does not exceed the minimum required for the proper wiring of the device and
- b) Each opening is located opposite a set of terminals.

*Exception: More than the minimum number of openings may be provided if the following items have been investigated:*

- a) *The possibility of conductors entering other points that are not opposite the terminals to which they are intended to be connected and*
- b) *The possibility of contacting insulated conductors or uninsulated current-carrying parts connected to a different circuit.*

23.3.4 To determine if a product complies with the requirement in 23.3.1, it is to be wired as it would be in service. A reasonable amount of slack is to be left in each conductor, within the enclosure, and no more than average care is to be exercised in stowing this slack into the wiring compartment.

## PROTECTION AGAINST INJURY TO PERSONS

### 24 General

24.1 An enclosure, an opening, a frame, a guard, a knob, a handle, or the like shall not be sufficiently sharp to cause a risk of injury to persons in normal maintenance or use.

24.2 If the breakage or damage of a part such as an enclosure, a frame, a guard, or the like may result in a risk of injury to persons, the material shall have such properties that comply with the demand of expected loading conditions.

24.3 The requirements in 24.2 apply to those portions of a part adjacent to a moving part or an exposed live part considered to present a risk of injury to persons.

### 25 Rotating Parts

25.1 A rotating member shall be constructed and made of materials having the necessary strength to reduce the likelihood of breakage or its release, or loosening of a part that could cause injury to persons.

25.2 A rotating part shall be assembled:

- a) So that the direction of rotation tends to tighten the means that holds the rotating part in place or
- b) Using a keyed nut or a nut locked in place with a pin or other positive means.

### 26 Enclosures and Guards

26.1 Each moving part that can cause injury to persons shall be enclosed or guarded.

*Exception: A moving part that can cause injury to persons that is necessarily exposed to perform the work function need not be enclosed or guarded. See 26.2.*

26.2 Among the factors to be considered in evaluating the acceptability of an exposed moving part are:

- a) Degree of exposure necessary to perform its intended function,
- b) Sharpness of the moving part,
- c) Likelihood of unintentional contact therewith,
- d) Speed of the moving part, and
- e) Likelihood that a part of the body would be endangered or that clothing would be entangled by the moving part.

These factors are to be considered with respect to both intended operation of the product and its reasonably foreseeable misuses.

## 27 Impact Test

27.1 A part as mentioned in 24.2 shall withstand the impact test described in 27.2, 27.3 and 27.5 to the extent that:

- a) A moving part involving a risk of injury to persons or an exposed live part cannot be contacted by the probes illustrated in Figures 6.2 or 6.3 for ceiling mounted appliances and
- b) The appliance complies with the Dielectric Voltage-Withstand Test, Section 42.

27.2 A smooth steel sphere, 2 inches (51 mm) in diameter and weighing approximately 1.18 pounds (535 g), is to fall vertically from rest through a distance of 51 inches (1.3 m) to strike the part being tested. For a part not able to be struck from above by the free-falling sphere, the sphere is to be suspended by a cord and swung as a pendulum through a vertical distance of 51 inches. A guard for an air cleaner that is intended to be ceiling-mounted is to be subjected to an impact of 1.5 foot-pounds (6.7 N). The sphere is to be dropped from a height of 15 inches (381 mm) or is to be swung as a pendulum dropping through a vertical distance of 15 inches.

27.3 If nonmetallic material is used for a part as mentioned in 24.2, the impact test is to be performed on a sample in the as-received condition. The test is then to be repeated on another sample that has cooled to room temperature after being conditioned for 7 hours in an air oven at uniform temperature not less than 10°C (18°F) higher than the maximum operating temperature of the material measured under intended operating conditions, but not less than 70°C (158°F).

27.4 Upon removal from the oven mentioned in 27.3 and before being subjected to the impact test, the samples shall not show checking, cracking or other deleterious effects from the oven conditioning. Also, the samples shall not show distortion sufficient to impair the intended operation of the product.

27.5 A nonmetallic part used in accordance with 24.2 and intended for outdoor use shall additionally be cooled to a temperature of minus 35 ±2°C (minus 31 ±4°F) and maintained at this temperature for 3 hours. While the unit is still cold, the samples shall be subjected to the impact tests described in 27.1 and 27.2.

## 28 Switches and Interlocks

### 28.1 Switches

28.1.1 If unintentional operation of a switch can result in risk of injury to persons, the actuator of the switch shall be located or guarded so that such operation is unlikely.

28.1.2 The actuator of a switch may be guarded by recessing, ribs, barriers, or the like.

## 28.2 Interlocks

28.2.1 A moving part that could cause injury to a person is considered to be guarded if protected by a cover with an interlock that complies with one of the following conditions:

- a) The part stops moving within 3 seconds after the cover is opened or
- b) The interlock prevents the cover from being opened until the part stops moving.

28.2.2 Operation of an interlock in normal use shall not inconvenience the operator so as to encourage deliberate defeat of the interlock.

28.2.3 An interlock shall be located so that unintentional operation is unlikely. The interlock shall not be readily defeatable without damaging the product, or without making wiring connections or alterations.

28.2.4 An interlock that is required to reduce a risk of electric shock or injury to persons shall withstand 100,000 cycles of operation controlling a load not less than that controlled in the air cleaner, and shall function normally upon completion of the test.

28.2.5 An interlock that is required to reduce the risk of electric shock shall open all supply conductors.

*Exception: For a permanently electrically connected unit (fixed type), the interlock need only open the ungrounded conductors.*

## 29 Stability

29.1 A portable or stationary product shall not overturn when tipped through an angle of 10 degrees from the horizontal as described in 29.2.

29.2 The product is not to be energized during the test mentioned in 29.1. The test is to be conducted under conditions most likely to cause the product to overturn. The following conditions of the test are to result in the least stability:

- a) The position of all doors, drawers, casters, and other movable or adjustable parts, including that of a supply cord, if any, resting on the surface supporting the air cleaner;
- b) Connection of or omission of any attachment made available by or recommended by the manufacturer; and
- c) Direction in which the product is tipped.

### 30 External Surface Temperatures

30.1 During the Temperature Test, Section 41, the temperature of a surface that may be contacted by the user shall not exceed the value specified in Table 30.1. If the test is to be conducted at a room temperature other than 25°C (77°F), the results are to be corrected to that temperature.

**Table 30.1**  
**Maximum surface temperatures**

Type of surface	Composition of surface <sup>a</sup>	
	Metallic	Nonmetallic
Handle or knob that is grasped for lifting, carrying or holding	50°C (122°F)	60°C (140°F)
Handle or knob that is contacted but does not involve lifting, carrying, or holding and other surfaces subject to contact in operation and user maintenance	60°C (140°F)	85°C (185°F)

<sup>a</sup> A handle, knob, or the like made of a material other than metal, that is plated or clad with metal having a thickness of 0.005 inch (0.13 mm) or less is to be evaluated as a nonmetallic part.

## PERFORMANCE

### 31 General

31.1 The performance of the product shall be investigated by subjecting a representative sample or samples in commercial form to the tests described in Sections 32 – 47. The tests shall be performed in the order presented (or as close as is practical). A sample employed for the Leakage-Current Test, Section 32, shall be tested for leakage current prior to being used for other tests.

31.2 Unless otherwise indicated, the tests are to be conducted at rated frequency and at the voltage specified in Table 31.1.

**Table 31.1**  
**Voltages for tests**

Voltage rating of product	Test potential, volts
110 – 120	120
220 – 240	240
254 – 277	277
440 – 480	480
550 – 600	600

## 32 Leakage Current Test

### 32.1 General

32.1.1 All exposed conductive surfaces of cord-connected products are to be tested for leakage currents. The leakage currents from these surfaces are to be measured to the grounded supply conductor individually as well as collectively if simultaneously accessible and from one surface to another if simultaneously accessible. Parts are considered to be exposed surfaces unless guarded by an enclosure that reduces the risk of electric shock, as described in Accessibility of Uninsulated Live Parts and Moving Parts, Section 6. Surfaces are considered to be simultaneously accessible if they can be readily contacted by one or both hands of a person at the same time.

32.1.2 Leakage current refers to all currents, including capacitively coupled currents, that may be conveyed between exposed conductive surfaces of a product and ground or other exposed conductive surfaces.

32.1.3 If the product has a direct-current rating, measurements are to be made with the product connected in turn to each side of a 3-wire, direct-current supply circuit.

### 32.2 Normal use

32.2.1 For a product rated 250 volts or less, the leakage current at any accessible part shall not be more than 0.5 milliamperes when tested in accordance with 32.2.2 – 32.2.4 if the open-circuit potential between the accessible part and earth ground or any other accessible part is more than:

- a) 42.4 volts peak for an indoor product or where wet contact is not likely to occur and
- b) 21.1 volts peak for an outdoor product and where wet contact is likely to occur.

32.2.2 The measurement circuit for the leakage-current test is to be as illustrated in Figure 32.1. The measurement instrument is defined in (a) – (c). The meter that is actually used for a measurement need only indicate the same numerical value for the particular measurement as would the defined instrument. The meter used need not have all of the attributes of the defined instrument.

- a) The meter is to have an input impedance of 1500 ohms resistive shunted by a capacitance of 0.15 microfarad.
- b) The meter is to indicate 1.11 times the average of the full-wave rectified composite waveform of voltage across the resistor or current through the resistor.
- c) Over a frequency range of 0 – 100 kilohertz, the measurement circuitry is to have a frequency response (ratio of indicated to actual value of current) that is equal to the ratio of the impedance of a 1500-ohm resistor shunted by a 0.15-microfarad capacitor to 1500 ohms. At an indication of 0.5 milliamperes, the measurement is to have an error of not more than 5 percent at 60 hertz.

**Figure 32.1**  
**Leakage current measurement circuit**

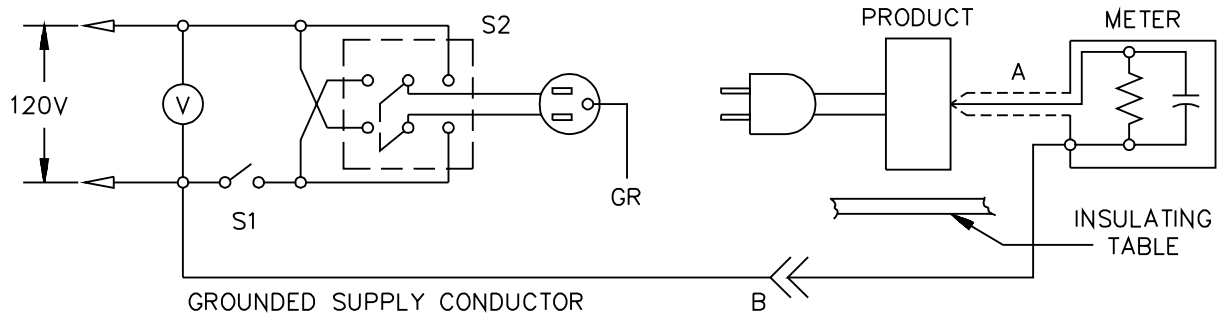

LC100

Product intended for connection to a 120-volt power supply

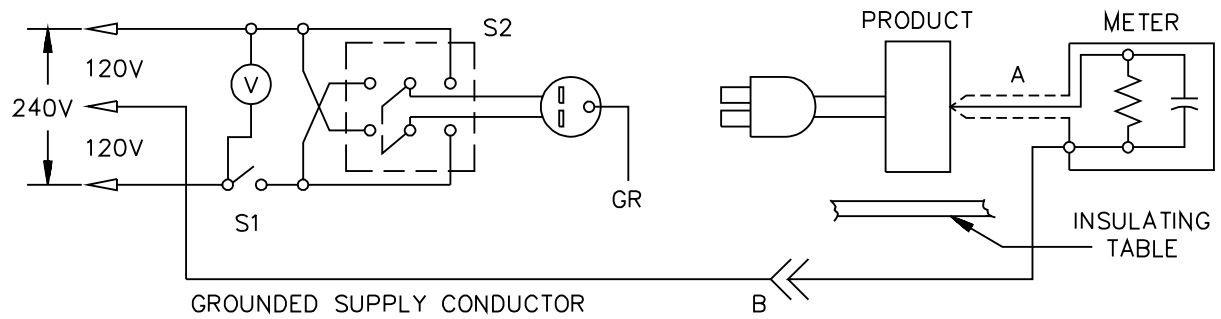

LC200

Product intended for connection to a 3-wire, grounded neutral power supply, as illustrated above.



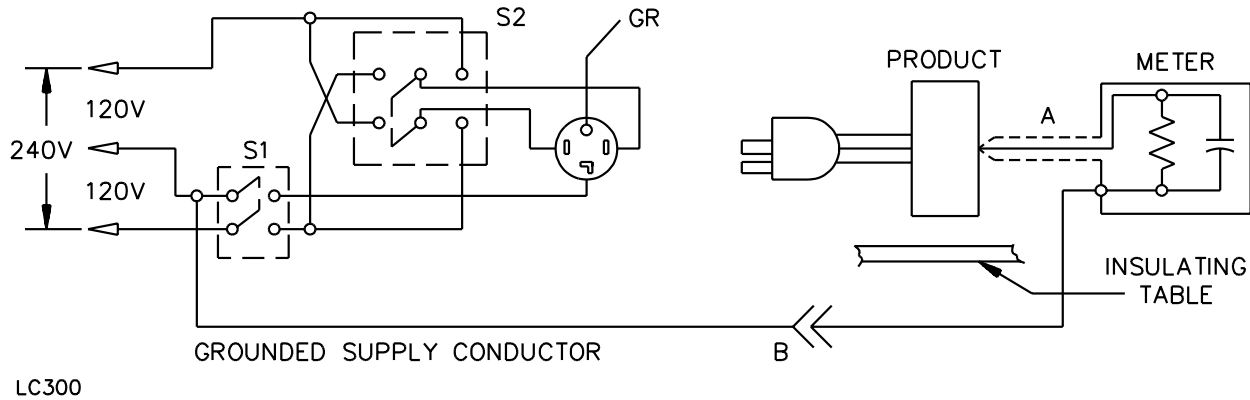

Product intended for connection to a 3-wire, grounded neutral power supply, as illustrated above.

A – Probe with shielded lead.

B – Separated and used as clip when measuring currents from one part of product to another.

32.2.3 Unless it is being used to measure leakage from one part of a product to another, the meter is to be connected between an accessible part and the grounded supply conductor.

32.2.4 A sample of the product is to be tested for leakage current first in the as-received condition with all switches and thermostats closed. The grounding conductor, if any, is to be open at the attachment plug. The as-received condition is without prior energization except for what may occur as part of the production-line testing. The supply voltage is to be 120 or 240 volts, as applicable. The test sequence, with reference to the measuring circuit in Figure 32.1, is to be as follows:

- a) With switch S1 open, the product is to be connected to the measuring circuit. Leakage current is to be measured using both positions of switch S2 and with the switching devices of the product in their normal operating positions.
- b) Switch S1 is then to be closed, energizing the product. Within five seconds, the leakage current is to be measured using both positions of switch S2, and with the switching devices of the product in their normal operating positions.
- c) The leakage current is to be monitored until thermal stabilization. Both positions of switch S2 are to be used in determining this measurement. Thermal stabilization is to be obtained by operation as described in the Temperature Test, Section 41.
- d) Leakage current is also to be monitored with switch S1 open while the product is at operating temperature and while cooling.

### 33 Leakage Current Following Humidity Conditioning

33.1 A product shall comply with the requirements for leakage current in 32.2.1, following exposure for 48 hours to air having a relative humidity of  $88 \pm 2$  percent at a temperature of  $32 \pm 2^\circ\text{C}$  ( $90 \pm 4^\circ\text{F}$ ).

33.2 To determine whether a product complies with the requirement in 33.2, a sample of the product is to be heated to a temperature just above  $34^\circ\text{C}$  ( $93^\circ\text{F}$ ) to reduce the likelihood of condensation of moisture during conditioning. The heated sample is to be placed in the humidity chamber and conditioned for 48 hours under the conditions specified in 33.1. Following the conditioning, the sample is to be tested unenergized as described in 32.2.4(a). The sample is then to be energized and tested as described in 32.2.4 (b) and (c). The test is to be discontinued when the leakage current stabilizes or decreases.

### 34 Partially Protected Parts

34.1 The following requirement applies to a product rated 250 volts or less. The continuous current flow through a 500-ohm resistor connected between any part exposed only during user servicing and earth ground or any other accessible part shall not be more than the applicable value specified in Table 34.1. However, this value only applies if the open-circuit potential between the part and earth ground or any other accessible part is more than:

- a) 42.4 volts peak for an indoor product or where wet contact is not likely to occur,
- b) 21.2 volts peak for an outdoor product and where wet contact is likely to occur.

See 32.1.1 – 32.1.3.

**Table 34.1**  
**Partially protected part available current**

Frequency, hertz <sup>a,b</sup>	Maximum current, milliamperes peak
0 – 100	7.1
500	9.4
1000	11.0
2000	14.1
3000	17.3
4000	19.6
5000	22.0
6000	25.1
7000 or more	27.5

<sup>a</sup> Linear interpolation between adjacent values may be used to determine the maximum current corresponding to frequencies not shown. The table applies to repetitive nonsinusoidal or sinusoidal waveforms.

<sup>b</sup> For a composite current (combination of a continuous direct current and alternating current) the frequency is based on the alternating current of the combination waveform. The composite waveform is not to exceed 27.5 milliamperes.

34.2 The measurements of the available current of partially protected parts are to be made under the following conditions:

- a) With any operating control, or adjustable control that is considered subject to user operation, in all possible positions of contact.
- b) Either with or without cells, separable connectors, and similar devices in place.

- c) For each loading condition specified in 35.2.
- d) A secondary or resonating winding shunted by a capacitance is to be tested with and without the capacitance.
- e) Each output terminal in turn is to be loaded to ground with wire-wound resistors, or a triode vacuum tube, varying from open circuit to short circuit in order to simulate loading conditions. Resistors, capacitors, diodes, and other solid-state components are in turn to be short-circuited or open-circuited.

*Exception No. 1: A current-limiting resistor within the power supply that does not exceed 70°C (126°F) during the normal temperature test specified in the Temperature Test, Section 41, is not to be short- or open-circuited.*

*Exception No. 2: The available current need not be measured if a circuit protector, such as a fuse or circuit breaker, opens the circuit within 1 second of energization of the unit.*

### **35 Input Test**

35.1 The current or volt-ampere input to the product under any normal operating condition shall not exceed 110 percent of the marked rating.

35.2 To determine whether the power pack complies with the requirement in 35.1, the current and power input is to be measured while the equipment is operated at the secondary voltage and current settings that result in maximum input for each of the following conditions, when applicable to the unit:

- a) Variable resistance connected from positive to negative output terminal and adjusted from open to short circuit.
- b) Variable resistance connected from positive output terminal to ground, negative terminal open-circuited, resistance varied from open to short circuit.
- c) As specified in (b) except negative terminal short-circuited to ground.
- d) Variable resistance connected from negative output terminal to ground, positive terminal open-circuited, resistance varied from open to short circuit.
- e) As specified in (d) except positive terminal short-circuited to ground.

### 36 Output Test

36.1 When the high-voltage circuit is delivering its rated load, the secondary-output voltage shall not be greater than 110 percent of the rated value.

36.2 The secondary-output voltage under all conditions of operation up to and including open-circuit shall be determined. The values obtained shall be used in determining the spacings required and the voltages to be employed during the Dielectric Voltage-Withstand Test, Section 42.

### 37 Ozone Test

37.1 A portable product for household use shall not produce a concentration of ozone exceeding 0.05 parts per million by volume when tested as described in 37.2 – 37.7.

37.2 The test is to be conducted in a room having a volume of 950 – 1100 cubic feet (26.9 – 31.1 m<sup>3</sup>) with a minimum side dimension of 8 feet (2.4 m) and a maximum height dimension of 10 feet (3.0 m) without openings. The test room walls and ceiling are to be covered with a sheet of polyethylene or aluminum. The floor is to be of a nonporous material such as vinyl tile or aluminum.

37.3 During the test, the test room is to be maintained at a temperature of  $25 \pm 2^{\circ}\text{C}$  ( $77 \pm 4^{\circ}\text{F}$ ) and a relative humidity of  $50 \pm 5$  percent. Prior to the start of and immediately after this test, the ozone background level is to be measured with the product off. The background level average shall be calculated and subtracted from the maximum measurement during the test.

37.4 The product is to be located in the center of the test room floor and about 30 inches (762 mm) above the floor for a table-mounted product.

37.5 The ozone monitor sampling tube is to be located 2 inches (50 mm) from the air outlet of the product and is to point directly into the air stream.

37.6 The emission of ozone is to be monitored for 24 hours to determine the concentration.

37.7 If the filter cell can be energized with any of its fans not functioning or with particle filters removed, the test described in 37.1 – 37.6 is to be repeated with the various components not operating or with particle filters removed.

### 38 Strain Relief Test

38.1 The strain-relief means provided with a flexible cord shall be tested as described in 38.2. The strain relief is not in compliance if, at the point of disconnection of the conductors, there is movement of the cord indicating that stress would have resulted on the connections.

38.2 The cord connections inside the product are to be disconnected. A 35-pound (15.9-kg) weight is to be suspended on the cord and supported by the product for 1 minute so that the strain-relief means is stressed from any angle that the construction of the product permits.

### 39 Pushback Relief Test

39.1 To determine compliance with 11.2.2.3, a product is to be tested as follows. The supply cord (or leads) is to be held 1 inch (25.4 mm) from the point where the cord emerges from the product. Then, the cord is to be pushed back with casual force as shown in Figure 39.1. The force is to be applied until the cord buckles, but in no case is the force to exceed 6 pounds-force (26.7 N).

**Figure 39.1**  
**Supply cord or lead push-back/strain relief evaluation**

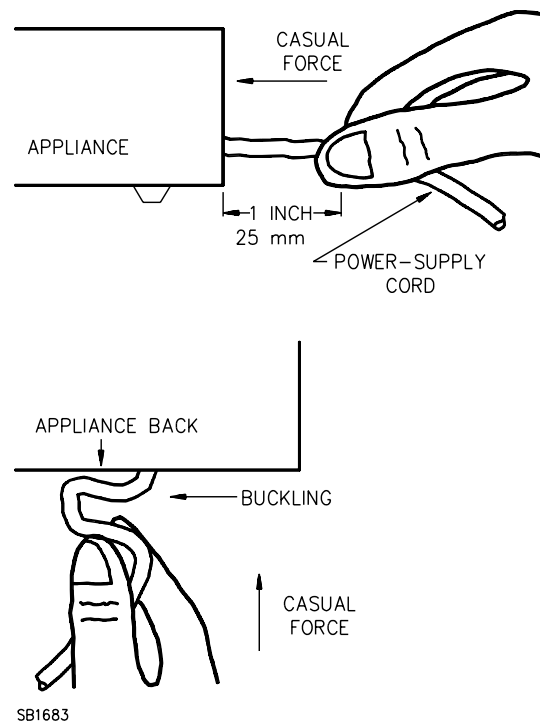

### 40 Grounding Resistance Test

40.1 The resistance of the grounding path between the equipment-grounding means and any other metal part required to be grounded (see 13.1.2) shall not be more than 0.1 ohm when measured in accordance with 40.2.

40.2 The resistance may be determined by any convenient method, such as an ohmmeter. If the current capacity of the grounding path is questionable, either a direct or alternating current equal to 200 percent of the maximum current that is available is to be passed from the equipment-grounding means to the metal part in question. The resulting drop in potential is to be measured between these two points. The resistance in ohms is to be determined by dividing the drop in potential in volts by the current in amperes that passes between the two points.

#### 41 Temperature Test

41.1 A product is to be tested under the conditions of load as described in 41.2 – 41.5. During the test:

- a) The temperature at any point shall not be sufficiently high to constitute a risk of fire or to adversely affect any materials used in the product,
- b) The temperature at specific points shall not exceed those specified in Tables 30.1 and 41.1.
- c) A motor-protective device shall not operate, and
- d) A resistor shall neither burn out nor otherwise be adversely affected.

**Table 41.1**  
**Maximum temperatures**

Materials and components	°C	(°F)
<b>A. MOTORS</b>		
1. Class A insulation systems on coil windings of an A-C motor having a frame diameter of 7 inches (178 mm) or less, not including a universal motor: <sup>a,b</sup>		
a. In an open motor:		
Thermocouple or resistance method	100	212
b. In a totally enclosed motor:		
Thermocouple or resistance method	105	221
2. Class A insulation systems on coil windings of a D-C motor and of a universal motor: <sup>a</sup>		
a. In an open motor:		
Thermocouple method	90	194
Resistance method	100	212
b. In a totally enclosed motor:		
Thermocouple method	95	203
Resistance method	105	221
3. Class B insulation systems on coil windings of an A-C motor having a frame diameter of 7 inches or less, not including a universal motor: <sup>a,b</sup>		
a. In an open motor and on vibrator coils:		
Thermocouple or resistance method	120	248
b. In a totally enclosed motor:		
Thermocouple or resistance method	125	257
4. Class insulation systems on coil windings of a D-C motor and of a universal motor: <sup>a</sup>		
a. In an open motor:		

Table 41.1 Continued on Next Page

Table 41.1 Continued

Materials and components	°C	(°F)
Thermocouple method	110	230
Resistance method	120	248
b. In a totally enclosed motor:		
Thermocouple method	115	239
Resistance method	125	257
<b>B. COMPONENTS</b>		
1. Capacitors		
a. Electrolytic <sup>c</sup>	56	149
b. Other types <sup>d</sup>	90	194
2. Solid and built-up contacts, bus bars, and connecting bars	90	194
3. Field-wiring terminals <sup>e</sup>	75	167
4. Fuses	90	194
5. Knife-switch blades and contact jaws	55	131
6. Potting compound	15	27
		less than melting point
7. Relay, solenoid, and coils (except motor coil windings and transformers) with:		
a. Class 105 insulation systems:		
Thermocouple method	90	194
Resistance method	100	212
b. Class 130 insulation systems:		
Thermocouple method	110	230
Resistance method	120	248
8. Resistors <sup>f</sup>	–	–
9. Transformers		
a. Class 105 insulation systems:		
Thermocouple method	90	194
Resistance method	100	212
b. Class 130 insulation systems:		
Thermocouple method	110	230
Resistance method	120	248
10. Selenium rectifier <sup>g,h</sup>	75	167
11. Silicon rectifier <sup>g</sup>	100	212
<b>C. CONDUCTORS</b>		
1. Rubber or thermoplastic insulated wire and cord <sup>g,i</sup>	60	140
<b>D. ELECTRICAL INSULATION – GENERAL</b>		
1. Fiber used as electrical insulation	90	194
2. Phenolic composition used as electrical insulation or as a part the deterioration of which could result in a risk of fire or electric shock <sup>g</sup>	150	302
3. Varnished-cloth insulation	85	185
<b>E. OTHER SURFACES</b>		
1. A surface upon which a product may be placed or mounted in service, and surfaces that may be adjacent to the product when it is so placed or mounted	90	194
2. Any point on or within a terminal box or wiring compartment of a stationary product in which power-supply conductors are to be connected	60	140
3. Wood or other combustible material	90	194
NOTE – The values in Table 41.1 are based on an ambient temperature of 25°C (77°F). However, a test may be conducted at any ambient temperature within the range of 10 – 40°C (50 – 104°F). Each observed temperature shall satisfy the following formula:		

Table 41.1 Continued on Next Page

Table 41.1 Continued

Materials and components	°C	(°F)
$T_1 + (K - T_A) \geq T_L$		
<p><i>in which:</i></p> <p><math>T_1</math> is the observed temperature of the material or component,</p> <p><math>K</math> is 25 when temperatures are measured in degrees Celsius and 77 when measured in degrees Fahrenheit,</p> <p><math>T_A</math> is the ambient room temperature, and</p> <p><math>T_L</math> is the maximum required temperature.</p> <p>If the ambient temperature is not 25°C, and the corrected temperature or the observed temperature exceeds the value in Table 41.1, the test may be repeated at an ambient temperature closer to 25°C.</p> <p><sup>a</sup> At a point on the surface of a coil where the temperature is affected by an external source of heat, the temperature measured by a thermocouple may be more than the specified maximum by the amount in the following table if the temperature of the coil, measured by the resistance method, is not more than that specified:</p>		
Reference in Table 41.1	Additional temperature,	
	°C	(°F)
Part A, item 1	5	9
Part A, items 2 and 4	15	27
<p><sup>b</sup> The diameter of a motor is the frame diameter, measured in the plane of the lamination, of the circle circumscribing the stator frame, excluding lugs, fins, boxes, and the like, used solely for motor mounting, cooling, assembly, or connection.</p> <p><sup>c</sup> For an electrolytic capacitor that is physically integral with or physically attached to a motor, the temperature or insulating material integral with the capacitor enclosure shall not be greater than 90°C (194°F).</p> <p><sup>d</sup> A capacitor that operates at a temperature of more than 90° (194°F) may be evaluated on the basis of its marked temperature limit.</p> <p><sup>e</sup> The temperature on a wiring terminal or lug is measured at the point most likely to be contacted by the insulation of a conductor installed as in actual service.</p> <p><sup>f</sup> See 34.2.</p> <p><sup>g</sup> The limitations do not apply to materials or compounds that have been investigated and determined to be acceptable for use at higher temperatures.</p> <p><sup>h</sup> A temperature of 85°C (185°F) complies if a stack assembly is insulated with phenolic composition or other insulating material rated for a temperature of 150°C (302°F).</p> <p><sup>i</sup> Rubber-insulated conductors within a motor having a Class A insulation system, rubber-insulated motor leads, and a rubber-insulated flexible cord entering a motor may be subjected to a temperature greater than 60°C (140°F) if a braid is used on the conductor of other than a flexible cord. This does not apply to thermoplastic-insulated wires or cords.</p>		

41.2 Maximum load is to be any load from open circuit to short circuit to simulate actual loading conditions and to produce each of the following:

- a) Maximum output current,
- b) Maximum input current, and



- c) Maximum input power.

The test is also to be conducted under short-circuit and open-circuit conditions. The load is to be applied to each output of the power pack to produce the specified maximum conditions.

41.3 With reference to 41.2, maximum conditions may be obtained by connecting the power-pack output to the maximum number of filter cells for which it is intended. As an alternative an ionizer output terminal, if employed, may be connected to a resistive load, and the collector output may be connected to a capacitive load.

41.4 To determine whether a product complies with the requirements in 41.1 – 41.3, it is to be connected to a supply of rated voltage and operated continuously until constant temperatures have been reached.

*Exception: If a component obviously is not intended for continuous operation, the temperature test may be conducted to take into consideration the probable intermittent or short time operation of the component.*

41.5 A product that is rated for use at more than one voltage or for a range of voltages, and contains a tapped transformer or other means of being adapted to different supply voltages, is to be tested at the most unfavorable combination of supply voltage and internal adjustment.

*Exception: The product may be tested while connected in accordance with the manufacturer's instructions if all three of the following conditions are met:*

- a) A clear, permanent marking is provided adjacent to the cord or supply compartment to warn the user that internal adjustments must be made when the appliance is installed or moved.*
- b) Detailed instructions clearly showing the adjustments that must be made for various voltages are permanently attached to the appliance. These instructions may be on the outside or on the inside of the overall enclosure where visible at the point at which adjustments for supply voltages must be made.*
- c) The adjusting means provided for different voltages complies with the requirements for wiring terminals in 11.1.4.1 – 11.1.4.5.*

41.6 Thermal equilibrium is considered to exist only if three successive readings indicate no change when taken at the conclusion of each of three consecutive, equal intervals of time where the duration of the interval is the longer of the following:

- a) 5 minutes or
- b) 10 percent of the total test time elapsed previous to the start of the first interval.

41.7 Rubber and other materials likely to deteriorate are to be removed from feet and other supports of the product if absence of the material may result in higher temperatures.

41.8 Ordinarily, temperatures are to be measured by thermocouples applied to the hottest accessible parts, except that motor-coil temperatures may be determined by the resistance method if the coil is inaccessible for mounting thermocouples.

41.9 The thermocouples are to consist of wires not larger than No. 24 AWG (0.21 mm<sup>2</sup>) and not smaller than No. 30 AWG (0.05 mm<sup>2</sup>). The thermocouples and related instruments are to be accurate and calibrated in accordance with good laboratory practice. The thermocouple wire is to comply to the requirements specified in the Initial Calibration Tolerances for Thermocouples table in Temperature Measurement Thermocouples, ANSI/ISA MC96.1.

41.10 Whenever referee temperature measurements are necessary in connection with the heating of electrical equipment, thermocouples consisting of No. 30 AWG (0.05 mm<sup>2</sup>) iron and constantan wires and a potentiometer type of indicating instrument are to be employed.

41.11 A thermocouple junction and adjacent thermocouple lead wire are to be securely held in thermal contact with the surface of the material that is being measured. In most cases, thermal contact will result from securely taping or cementing the thermocouple in place. However, if a metal surface is involved, bracing or soldering the thermocouple to the metal may be necessary.

41.12 For the thermocouple-measured temperature of a coil in a motor the thermocouple:

- a) Is to be applied to the magnet wire;
- b) Is to be separated from the magnet wire by not more than the insulation on the conductor itself; or
- c) May be separated from the conductor by not more than the insulation on the conductor itself and the normal coil wrap.

*Exception: This requirement does not apply to a 7-inch (178 mm) diameter or smaller frame A-C motor as described in Table 41.1, part A, items 1 and 3.*

41.13 In using the resistance method, the windings are to be at room temperature at the start of the test. The temperature of a winding is to be calculated using the following:

$$T = \frac{R}{r} (k + t) - k$$

*in which:*

*T<sub>c</sub> is the temperature of the coil at the end of the test in degrees C;*

*R is resistance of the coil at the end of the test in ohms;*

*r is the resistance of the coil at the beginning of the test in ohms;*

*k is 234.5 for copper, and 225.0 for electrical conductor grade (EC) aluminum; values of the constant for other grades must be determined; and*

*t is the room temperature at the beginning of the test in degrees C.*

## 42 Dielectric Voltage-Withstand Test

### 42.1 General

42.1.1 A product shall withstand without breakdown for 1 minute the application of 60-hertz sinusoidal potential as follows:

- a) Twice the maximum rated primary voltage plus 1000 volts between the primary circuit and exposed or grounded dead metal.
- b) 125 percent of the maximum measured or rated secondary voltage, whichever is higher, between primary and secondary windings, and between secondary and resonating windings.

*Exception: This test is to be omitted if any point of the secondary winding is grounded. If the resonating winding and the high-voltage windings are common, the test between the resonating winding and the secondary winding is to be omitted.*

- c) 150 of the maximum rated primary voltage applied to the ends of the primary winding with one end of the primary winding connected to the enclosure. See 42.1.2.

*Exception: A direct-current potential may be used for a direct-current circuit.*

42.1.2 With reference to 42.1.1(c), the frequency may be adjusted higher if needed. If the transformer does not have a grounded secondary winding, this test is to be conducted first with one end of the secondary, and then the other end, connected to the common connection of the primary and enclosure. If the transformer has a point other than an end point of its secondary windings grounded, the test is to be performed as described, but without an electrical connection between either end of the secondary and the common connection of the primary and enclosure.

42.1.3 Each component of a product that is subjected to dc potentials during normal operation of the equipment shall withstand without breakdown for 1 minute, the application of a dc potential of 150 percent of the rated or measured dc voltage, whichever is greater, between that component and grounded metal. The values to be used in this test shall be based on the voltages measured in the Output Test, Section 36. The value used shall be the highest voltage existing at that component under any condition of operation.

42.1.4 The ionizer and collector cells are to be removed during the test described in 42.1.3.

42.1.5 If the application of a d-c potential of 150 percent of the measured dc voltage of one point causes the rated dc potential of another point to be more than 150 percent of the maximum voltage at these points, other places in the circuit may be grounded to prevent the excessive voltage condition from occurring.

42.1.6 Each meter provided with a product is to be disconnected from the circuit when the product is subjected to the dielectric voltage-withstand tests described in 42.1.1 – 42.1.5. Each meter is then to be separately subjected to the dielectric voltage-withstand tests in 42.1.1 and 42.1.3.

42.1.7 In determining whether a product complies with the requirements in 42.1.1 – 42.1.6, the applied potential is to be increased from zero until the required test level is reached, and is to be held at that level for 1 minute. The increase in the applied potential is to be at a substantially uniform rate that is and as rapid as is consistent with the value correctly indicated by a voltmeter.

## **42.2 High-voltage transformer core**

42.2.1 An ungrounded high-voltage transformer core can be used if it withstands a dielectric voltage-withstand test of four times the maximum secondary voltage applied from the core to the primary and secondary windings connected together. The potential is to be applied for 1 minute. See the Exception to 13.1.2.

## **42.3 Induced potential**

42.3.1 Three samples of a magnet coil winding as described in 22.3.4 and 22.3.5 are to be subjected to this test. While in a heated condition from operation as described in the Temperature Test, Section 41, the primary winding of each transformer shall withstand without breakdown an alternating potential of twice the rated voltage of the winding.

42.3.2 The potential is to be:

- a) Applied for 7200 cycles if the test potential frequency is 120 hertz or more and
- b) 60 seconds if the frequency is less than 120 hertz.

A higher test frequency may be necessary so the core is not saturated. The test voltage is to be started at one-quarter or less of the full value and increased to full value in not more than 15 seconds. After being held for the time specified, the voltage is to be reduced within 5 seconds to one-quarter or less of the maximum value and the circuit is to be opened.

42.3.3 With reference to 42.3.1, a transformer may be conditioned in an oven to obtain the temperature reached in the Temperature Test, Section 41, before conducting the induced-potential test.

## **43 Stored Energy Test**

43.1 The voltage across a capacitance at the time the capacitance is accessible during user servicing, 5 seconds or more after the power supply to the appliance has been interrupted by the removal of an interlocked cover, or the like, shall not exceed the applicable value specified in Table 43.1.

**Table 43.1**  
**Stored energy**

Capacitance, microfarads	Maximum potential across capacitance, prior to discharge, volts <sup>a</sup>
0.0030	40,000
0.0037	35,000
0.0047	30,000
0.0062	25,000
0.0087	20,000
0.014	15,000
0.025	10,000
0.074	5,000
0.89	1,000
1.04	900
1.25	800
1.54	700
1.95	600
2.59	500
3.65	400
3.97	380
4.34	360
4.79	340
5.27	320
5.86	300
6.57	280
7.43	260
8.49	240
9.81	220
11.5	200
13.7	180
16.8	160
21.0	140
27.4	120
37.5	100
45.0	90
55.2	80
69.9	70
91.8	60
127.0	50
154.0	45
172.0	42.4
191.0	40
327.0	30
464.0	25
642.0	21.2

<sup>a</sup> Linear interpolation between adjacent values in the tables is to be used to determine the maximum required voltages corresponding to capacitance not specified in the table.

## 44 Evaluation of Reduced Spacings on Printed-Wiring Boards

### 44.1 General

44.1.1 In accordance with Exception No. 3 to 22.3.1 and Exception No. 5 to 22.4.1, printed-wiring board traces of different potentials in the same circuit having reduced spacings may be evaluated by conducting the shorted trace test described in 44.2.1 – 44.2.4.

### 44.2 Shorted trace test

44.2.1 Printed-wiring board traces mentioned in 44.1.1 are to be tested as described in 44.2.2 – 44.2.4. As a result of the testing:

- a) The overcurrent protection associated with the branch circuit to the unit shall not open,
- b) The ground circuit fuse shall not open,
- c) A wire or a printed-wiring board trace shall not open, and
- d) The device shall emit no flame or molten metal.

44.2.2 Following each shorted trace test, the device is to be subjected to the Dielectric Voltage-Withstand Test, Section 42.

44.2.3 Each location of reduced spacings between the traces on the printed-wiring board is to be tested separately. The traces at each location are to be short-circuited by connecting them together with a conductor having an ampacity high enough not to affect the test results prior to energizing the air cleaner. Exposed dead metal parts of the air cleaner are to be connected to ground through a 3-ampere nontime-delay fuse. The air cleaner is to be connected in series with a nontime-delay fuse of the maximum current rating that can be accommodated by the fuseholder of a branch circuit to which the air cleaner could be connected. The air cleaner is to be energized as in normal use.

44.2.4 Each test is to be continued until further changes, as a result of the test condition, are not likely. If the circuit is interrupted by the opening of a component, the test is to be repeated twice using new components as necessary.

## 45 Abnormal Operation Test

### 45.1 General

45.1.1 A product shall not cause a risk of fire or electric shock when operated under abnormal conditions that may occur during use. During the tests specified in 45.2.1 – 45.5.1:

- a) The cheesecloth mentioned in 45.1.2 shall not glow or flame;
- b) The tissue paper mentioned in 45.1.2 shall not glow or flame;
- c) The fuse in the ground circuit shall not open; and
- d) A permanent path shall not result between live parts and exposed metal, as determined by a repeat of the Leakage-Current Test, Section 32.

45.1.2 During the abnormal operation test, the product is to be connected in series with a nontime-delay fuse of the maximum current rating that can be accommodated by the fuseholder of a branch circuit to which the product could be connected. The product complies with the test if the branch-circuit fuse opens before any risk of fire or electric shock is evident. If an automatically reset protector functions in the air cleaner, the test is to be continued for 7 hours. If a manual reset protector functions, the test is to be continued until the protector operates for 10 cycles using the minimum resetting time, but not at a rate faster than 10 cycles of operation per minute. The protector is to be operational upon completion of the test. Only one abnormal condition is to be simulated at a time. Abnormal operation tests are to be conducted with the product supported in its normal operating position. A portable product is to be placed on a pine board covered with white tissue paper. All products are to be covered with cheesecloth as described in 45.1.6, arranged so that the cloth is close to any openings in the enclosure. Exposed dead metal parts are to be connected to ground through a 3-ampere nontime-delay fuse.

45.1.3 Parts that may be removed during user servicing may be removed if they are not:

- a) Necessary for the functioning of the product,
- b) Exposed to view during operation, and
- c) Held captive.

45.1.4 The tests specified in 45.2.1 – 45.4.3 are first to be conducted with a resistive load connected to the output terminals so that three times the full-rated current will be drawn from the secondary winding. The test is to be repeated with the transformer secondary winding or windings shorted.

45.1.5 As a risk of fire or electric shock resulting from the abnormal operation tests will usually manifest itself within 1 hour, the tests are ordinarily to be limited to 1 hour. If at the end of 1 hour it appears possible that risk of fire or electric shock will eventually result, the test is to be continued until ultimate results are obtained (usually not more than 7 hours).

45.1.6 The cheesecloth mentioned in 45.1.2 is to be untreated cotton cloth 36 inches (0.9 m) wide, running 14 – 15 yards per pound (28 – 30 m/kg). Tests involving cheesecloth are to be conducted in a room free of drafts.

## **45.2 High-voltage supply**

45.2.1 A power supply with an output that exceeds the limits in Partially Protected Parts, Section 34, is to be tested with the controls adjusted for maximum output voltage and current under each of the following conditions:

- a) With the ionizer output terminal, if employed, shorted to ground.
- b) With the collector terminal shorted to ground.
- c) With any ungrounded end of the secondary winding of the high-voltage transformer core. For a transformer having a completely insulated center-tapped winding, one-half of the secondary winding is to be shorted in lieu of connection to the core.

*Exception: For a transformer having an untapped, completely insulated secondary winding, the test in (c) may be omitted.*

## **45.3 High-voltage spacings short circuit**

45.3.1 The spacings referenced in Exception No. 1 to 22.4.1 are to be short-circuited in turn.

## **45.4 Unenclosed high-voltage power supply**

45.4.1 A product having a high-voltage power supply not enclosed as described in 5.2.2(a) shall comply with the requirements in 45.4.2 – 45.5.1.

45.4.2 An arc is to be established between parts that have a potential difference greater than 2500 volts peak using a conductive probe. Materials located between the parts are to be located in the path of the arc. The test is to be continued for 15 minutes unless the glowing or flaming occurs in a shorter time. Three samples are to be tested.

45.4.3 All secondary windings (including the resonant winding of the transformer, if provided) are to be short-circuited at the same time. If the circuit is interrupted by the opening of a component, the test is to be conducted a total of three times using new components when necessary.



## 45.5 Component short- and open-circuit test

45.5.1 Each high-voltage output is to be loaded as indicated in 41.3. Each component, such as a capacitor, a diode, a solid state device, or the like, connected in the line-voltage circuit is to be short-circuited and then open-circuited one component at a time.

## 46 Metallic Coating Thickness Test

46.1 The method of determining the thickness of a zinc or cadmium coating by test is described in 46.2 – 46.9.

46.2 The solution used for this test is to:

a) Be made from distilled water,

b) Is to contain 200 grams per liter of American Chemical Society (ACS) reagent grade chromic acid ( $\text{CrO}_3$ ), and 50 grams per liter of ACS reagent grade concentrated sulfuric acid ( $\text{H}_2\text{SO}_4$ ). The latter is equivalent to 27 milliliters per liter of ACS reagent grade concentrated sulphuric acid, specific gravity 1.84, containing 96 percent of  $\text{H}_2\text{SO}_4$ .

46.3 The test solution is to be contained in a glass vessel such as a separatory funnel with the outlet equipped with a stopcock and a capillary tube having an inside bore of 0.025 inch (0.64 mm) and a length of 5.5 inches (140 mm). The lower end of the capillary tube is to be tapered to form a tip. The drops exiting the tube are to be about 0.025 milliliters each. To preserve an effectively constant level, a small glass tube is to be inserted in the top of the funnel through a rubber stopper. Its position is to be adjusted so that, when the stopcock is open, the rate of dropping is  $100 \pm 5$  drops per minute. If desired, an additional stopcock may be used in place of the glass tube to control the rate of dropping.

46.4 The sample and the test solution are to be kept in the test room for a duration that will enable them to reach room temperature. This is to be noted and recorded. The test is to be conducted at an ambient temperature of  $21.1 - 32.2^\circ\text{C}$  ( $70 - 90^\circ\text{F}$ ).

46.5 Each sample is to be thoroughly cleaned before testing. All grease, lacquer, paint, and other nonmetallic coating are to be removed completely by means of solvent. Samples are then to be thoroughly rinsed in water and dried. Care is to be exercised to avoid contact of the cleaned surface with the hands or any foreign material.

46.6 The sample to be tested is to be supported from 0.7 – 1 inch (17.8 – 25.4 mm) below the orifice, so that the drops of solution strike the point to be tested and run off quickly. The surface to be tested is to be inclined about 45 degrees from horizontal.

46.7 The stopcock is to be opened and the time in seconds is to be measured until the dropping solution dissolves the protective metallic coating, exposing the base metal. The end point is the first appearance of the base metal recognizable by a change in color.

46.8 Each sample of a test lot is to be tested at three or more points (excluding cut, stenciled, and threaded surfaces) on the inside surface and at an equal number of points on the outside surface, at places where the metallic coating may be expected to be the thinnest. On enclosures made from precoated sheets, the external corners that are subjected to the greatest deformation are likely to have thin coatings.

46.9 To calculate the thickness of the coating being tested, select from Table 46.1 the thickness factor appropriate from the temperature at which the test was conducted and multiply by the time in seconds required to expose base metal as described in 46.7.

**Table 46.1**  
**Thickness of coatings**

Temperature,		Thickness factors 0.00001 inch (0.00025 mm) coatings per second	
°F	(°C)	Cadmium platings	Zinc platings
70	21.1	1.331	0.980
71	21.7	1.340	0.990
72	22.2	1.340	1.000
73	22.8	1.362	1.010
74	23.3	1.372	1.015
75	23.9	1.383	1.025
76	24.4	1.395	1.033
77	25.0	1.405	1.042
78	25.6	1.416	1.050
79	26.1	1.427	1.060
80	26.7	1.438	1.070
81	27.2	1.450	1.080
82	27.8	1.460	1.085
83	28.3	1.470	1.095
84	28.9	1.480	1.100
85	29.4	1.490	1.110
86	30.0	1.501	1.120
87	30.6	1.513	1.130
88	31.1	1.524	1.141
89	31.7	1.534	1.150
90	32.2	1.546	1.160

#### 47 High-Voltage Insulating Material Arcing Test

47.1 High-voltage insulating materials other than glazed porcelain, glass, or mica shall be tested as specified in 47.2. There shall not be heavy carbonizing, low resistive path, or ignition of the insulating material.

*Exception: Insulating materials used with parts that operate within the voltage and current limitations in Partially Protected Parts, Section 34.*

47.2 With regard to 47.1, the high-voltage output near the insulating material is to be connected to a pointed brass electrode placed at an angle 45 degrees to the surface of the insulating material under test. It is to be positioned in a manner to sustain a continuous arc until ultimate conditions are observed. The test may be discontinued in the event an integral nonautomatic protective device, such as a fuse, opens or the supply stops operating. The test is to be conducted at room ambient conditions.

47.3 Ignition as mentioned in 47.1 is considered to have occurred if the material continues to burn for any duration of time after the arc is removed.

#### 48 Permanence of Marking

48.1 A marking required to be permanent (durable and securely affixed) shall be molded, die-stamped, paint-stenciled, stamped or etched on metal, or indelibly stamped on pressure-sensitive labels secured by adhesive. Pressure-sensitive labels secured by adhesive shall comply with the Standard for Marking and Labeling Systems, UL 969. Ordinary usage, handling, storage of the product shall be considered in determining the permanence of marking.

### MANUFACTURING AND PRODUCTION TESTS

#### 49 Dielectric Voltage-Withstand Test

49.1 Each product shall withstand without electrical breakdown, as a routine production-line test, the application of a potential at a frequency within the range of 40 – 70 hertz, or a dc potential

- a) Between the primary wiring, including connected components, and accessible dead metal parts that are likely to become energized and
- b) Between primary wiring and accessible low-voltage, 42.4 volts peak or less, metal parts, including terminals.

49.2 The production-line test shall be conducted in the time and at the potential specified in either Condition A or Condition B of Table 49.1.

**Table 49.1**  
**Production-line test conditions**

Product rating	Condition A			Condition B		
	Potential, volts AC	Potential, volts DC	Time, seconds	Potential, volts AC	Potential, volts DC	Time, seconds
250 volts or less with no motor rated more than 1/2 horsepower (373 watts output)	1000	1400	60	1200	1700	1
250 volts or less with a motor rated more than 1/2 horsepower (373 watts output)	$1000 + 2V^a$	$1400 + 2.8V^a$	60	$1200 + 2.4V^a$	$1700 + 3.4V^a$	1
251 – 600 volts	$1000 + 2V^b$	$1400 + 2.8V^b$	60	$1200 + 2.4V^b$	$1700 + 3.4V^b$	1

<sup>a</sup> Maximum marked voltage but not less than 120 volts if the maximum marked voltage is within the range 105 – 120 volts, and not less than 240 volts if the maximum marked voltage is within the range 210 – 240 volts.

<sup>b</sup> Maximum marked voltage.

49.3 A product may be in a heated or unheated condition for the test.

49.4 The test is to be conducted with the product fully assembled. It is not intended that the product be unwired, modified, or disassembled for the test.

*Exception No. 1: A part such as a snap cover or a friction-fit knob that would interfere with performance of the test need not be in place.*

*Exception No. 2: The test may be performed before final assembly if the test represents that for the completed product.*

*Exception No. 3: A product employing a solid-state component that is not relied upon to reduce a risk of electric shock and that can be damaged by the dielectric potential may be tested before the component is electrically connected. However, a random sampling of each day's production is to be tested at the potential specified in Table 49.1. The circuitry may be rearranged for the purpose of the test to reduce the likelihood of solid-state-component damage while retaining representative dielectric stress of the circuit.*

49.5 The test equipment shall have a means of:

- a) Indicating the test potential,
- b) An audible or visual indicator of electrical breakdown, and
- c) Either a manually reset device to restore the equipment after electrical breakdown or an automatic reject feature of any noncomplying unit.

When an AC test potential is applied, the test equipment shall include a transformer having an essentially sinusoidal output.

49.6 If the output of the test-equipment transformer is less than 500 volt-amperes, the equipment shall include a voltmeter in the output circuit to directly indicate the test potential.

49.7 If the output of the test-equipment transformer is 500 volt-amperes or more, the test potential may be indicated:

- a) By a voltmeter in the primary circuit or in a tertiary-winding circuit;
- b) By a selector switch marked to indicate the test potential; or
- c) For equipment having a single test-potential output, by a marking in a readily visible location to indicate the test potential. If a marking is used without an indicating voltmeter, the equipment shall include a positive means, such as an indicator lamp, to indicate that the manually reset switch has been reset following a dielectric breakdown.

49.8 Test equipment other than that described in 49.5 – 49.7 may be used if determined to accomplish the intended factory control.

49.9 During the test,

- a) The primary switch is to be in the on position,
- b) Both sides of the primary circuit of the product are to be connected together and to one terminal of the test equipment, and
- c) The second test-equipment terminal is to be connected to accessible dead metal.

*Exception: A product having circuitry that is resistive, high-impedance winding, or the like and is not subject to excessive secondary-voltage build-up in case of electrical breakdown during the test may be tested:*

- a) With a single-pole primary switch, if used, in the off position;*
- b) With only one side of the primary circuit connected to the test equipment when the primary switch is in the on position; or*
- c) When a primary switch is not used.*

## **50 Grounding Continuity**

50.1 The manufacturer shall determine by a routine production-line test that each product required to have grounding means complies with the requirement in 13.1.2.

50.2 Electrical continuity is to be checked between:

- a) The external surface of the product and the metal portions of knobs or buttons that will be contacted by the user during operation of the product and
- b) For a cord-connected product, the grounding blade of the attachment plug, and
- c) For a permanently connected product, the grounding terminal of the product.

## **RATINGS**

### **51 Details**

51.1 The input of a product shall be rated in volts, frequency, and amperes, volt-amperes, or watts. A product shall be rated in amperes or volt-amperes if a wattage rating is not a close indication of the volt-ampere input.

## MARKINGS

### 52 Visible During Installation and Inspection

52.1 The markings required by 52.2 – 52.8 shall be permanent, except as noted in 52.2, plain, legible, and readily visible during installation and examination of the supply-wiring connections.

52.2 If a product is shipped in multiple cartons or not completely assembled when shipped from the factory (see 7.2.1 – 7.2.4) and if mismatching of components might result in a risk of fire, electric shock, or injury to persons each part shall be marked to indicate the other parts with which that part is intended for use. However, the marking may be on the package for small parts shipped in an envelope or other package.

52.3 Unless the proper wiring connections are plainly evident, wiring terminals shall be marked or the product shall have a wiring diagram to indicate the connections.

52.4 Information necessary for proper operation of the product and the selection of heaters for overload relays shall be provided.

52.5 With reference to wiring diagrams and installation instructions, the only connection that may be shown to a heating-cooling panel or furnace installation are those to be made to:

- a) Room thermostat terminals,
- b) The input or supply connections to a complete furnace, or
- c) The fan circuit on existing systems.

52.6 The wiring diagram shall clearly indicate that connections are to be made only at the points specified in 52.5 and shall not show other furnace components such as limit switches and heating controls that could possibly mislead installers to make connections at these locations.

52.7 If the maximum input of a product exceeds the full-load amperes, the locked-rotor amperes, or both, the wiring diagram, installation instructions, or both shall not indicate that the product is to be connected to the fan circuit of the heating-cooling panel or furnace.

52.8 If a low-voltage device or part of a device is intended to be wired in the field to become part of a Class 1 circuit or a Class 2 circuit wired with Class 1 wire, the terminals of the device or part shall be marked accordingly. A low-voltage switching or power-consuming device, or part of a device intended to be wired in the field to become part of a Class 2 circuit only shall be marked accordingly. A low-voltage power-supply device that includes a transformer is not required to be marked to indicate that it is for use in a Class 2 circuit only. A low-voltage device or part of a device that is acceptable for connections to either a Class 1 or Class 2 circuit is not required to be so marked. If wiring instructions are provided with the device, they shall not conflict with the requirements.

### 53 Visible After Installation

53.1 The markings required by 53.2 – 53.8 shall be permanent, plain, legible, and readily visible after the product is installed in the intended manner.

*Exception: A marking that is readily visible by opening a door or removing a cover after installation is considered to be in compliance if the installation wiring will not be disturbed by removing the cover.*

53.2 A product shall be legibly and permanently marked, with the manufacturer's name, trade name, or trademark; the date or other dating period of manufacture not exceeding any three consecutive months; a distinctive catalog number or the equivalent; and the electrical rating.

*Exception No. 1: The manufacturer's identification may be in a traceable code if the product is identified by the brand or trademark owned by a private labeler.*

*Exception No. 2: The date of manufacture may be abbreviated or may be in a nationally accepted conventional code or in a code that has been affirmed by the manufacturer, provided that the code:*

*a) Does not repeat in less than 10 years for a household product and less than 20 years for a commercial product and*

*b) Does not require reference to the production records of the manufacturer to determine when the product was manufactured.*

53.3 The marking on a product shall include the rating of a motor in volts and amperes unless the motor is 1/20 horsepower (37 W output) or less.

53.4 If a manufacturer produces or assembles products at more than one factory, each finished product shall have a distinctive marking by which it may be identified as the product of a particular factory.

53.5 The position of an operating handle shall be marked as a guide for proper operation.

53.6 The operating handle referred to in 53.5 is one that is provided to control the electrical function of a product.

53.7 Meters, pilot lights, and the like shall be marked to indicate their function.

53.8 A switch, other than a momentary contact switch, that controls the motor that drives a part that can cause injury to persons shall have a plainly marked off position.

## 54 Cautionary Markings

54.1 A cautionary marking shall be permanent, contrasting with its background, easily read, and on the outside of the overall enclosure.

54.2 In a cautionary marking, the word "CAUTION," "WARNING," or "DANGER" shall be in letters not less than 1/8 inch (3.2 mm) high. The remainder of the marking shall be in letters not less than 1/16 inch (1.6 mm) high.

54.3 Each product shall be plainly marked to indicate the presence of high voltage. The marking shall be preceded by the word "CAUTION."

54.4 Each product shall be marked with the word "CAUTION" and with the following or the equivalent: "This equipment should be inspected frequently and collected dirt removed from it regularly to prevent excessive accumulation that may result in flashover or a risk of fire."

54.5 A removable ionizer-collector cell of a product that is installed above floor level and that weighs more than 15 pounds (6.8 kg), shall be marked with the word "CAUTION" and the following or the equivalent: "This Cell Weighs \_\_\_\_\_ Pounds. Handle With Care When Removing For Cleaning or Servicing."

## 55 Manufacturer's Literature

55.1 A product shall be furnished with complete installation and operating instructions. The instructions shall not recommend any procedure that may result in a risk of fire, electric shock, or injury to persons.

55.2 If servicing instructions are provided, they shall be identified as servicing instructions, or the equivalent. They shall be separated from the installation and operating instructions in the manual or be provided in a separate manual.

55.3 If the servicing instructions of an air cleaner require access to parts that could result in a risk of electric shock, the servicing instructions shall be preceded by the signal word "WARNING" and the following or the equivalent: "RISK OF ELECTRIC SHOCK – These servicing instructions are for use by qualified personnel only. To reduce the risk of electric shock, do not perform any servicing other than that contained in the operating instructions unless you are qualified to do so."

55.4 Unless the proper method of assembly is obvious, a product that is shipped from the factory partially disassembled shall be provided with clear and detailed assembly instructions.

55.5 A duct- or plenum-mounted product shall be provided with installation instructions that include:

- a) The method of installation and user maintenance;
- b) A statement that the product is to be located so that connection can be made to the source of electrical supply without the use of an extension cord; and
- c) If intended for electrical connection to a furnace, the method of such electrical interconnection, a wiring diagram, and the intended location of the field-wiring compartment.



55.6 For equipment having a 2-blade polarized plug, the following instructions or the equivalent shall be provided: "To reduce the risk of electric shock, this equipment has a polarized plug (one blade is wider than the other). This plug will fit in a polarized outlet only one way. If the plug does not fit fully in the outlet, reverse the plug. If it still does not fit, contact qualified personnel to install the proper outlet. Do not alter the plug in any way."

55.7 For equipment having a grounding-type plug, the following instructions or the equivalent shall be provided: "To reduce the risk of electric shock, this equipment has a grounding type plug that has a third (grounding) pin. This plug will only fit into a grounding type power outlet. If the plug does not fit into the outlet, contact qualified personnel to install the proper outlet. Do not alter the plug in any way."

No Text on This Page

## APPENDIX A

### Standards for Components

Standards under which components of the products covered by this standard are evaluated include the following:

Title of Standard – UL Standard Designation

---

Air Filter Units – UL 900  
Cable, Armored – UL 4  
Capacitors – UL 810  
Circuit-Breaker Enclosures, Molded-Case Circuit Breakers, Molded-Case Switches, and – UL 489  
Components for Television-Type Appliances, High-Voltage – UL 1413  
Cord and Fixture Wire, Flexible – UL 62  
Cord Sets and Power-Supply Cords – UL 817  
Double Insulation Systems for Use in Electrical Equipment – UL 1097  
Enclosures for Electrical Equipment – UL 50  
Fittings for Cable and Conduit – UL 514B  
Fuseholders – UL 512  
Insulating Materials – General, Systems of – UL 1446  
Insulating Tape, Polyvinyl Chloride, Polyethylene, and Rubber – UL 510  
Insulating Tubing, Extruded – UL 224  
Lampholders, Edison-Base – UL 496  
Motor-Operated Appliances – UL 73  
Motors, Electric – UL 1004  
Outlet Boxes, Flush-Device Boxes, and Covers, Nonmetallic – UL 514C  
Outlet Boxes, Metallic – UL 514A  
Plastic Materials for Parts in Devices and Appliances, Tests for Flammability of – UL 94  
Plugs and Receptacles, Attachment – UL 498  
Polymeric Materials – Fabricated Parts – UL 746D  
Polymeric Materials – Long Term Property Evaluations – UL 746B  
Polymeric Materials – Short Term Property Evaluations – UL 746A  
Polymeric Materials – Use in Electrical Equipment Evaluations – UL 746C  
Power Units Other Than Class 2 – UL 1012  
Printed-Wiring Boards – UL 796  
Switches, Clock-Operated – UL 917  
Switches, Special-Use – UL 1054  
Temperature-Indicating and -Regulating Equipment – UL 873  
Terminal Blocks – UL 1059  
Terminals, Electrical Quick-Connect – UL 310  
Transformers, Specialty – UL 506  
Wire Connectors and Soldering Lugs for Use With Copper Conductors – UL 486A  
Wire Connectors for Use With Aluminum Conductors – UL 486B  
Wires and Cables, Thermoplastic-Insulated – UL 83  
Wires and Cables, Thermoset-Insulated – UL 44

No Text on This Page