

UL 197

ISBN 1-55989-546-X

Commercial Electric Cooking Appliances

Underwriters Laboratories Inc. (UL)
333 Pfingsten Road
Northbrook, IL 60062-2096

UL Standard for Safety for Commercial Electric Cooking Appliances, UL 197

Eighth Edition, Dated June 1, 1993

Revisions: This Standard contains revisions through and including April 10, 2000.

UL is in the process of converting its Standards for Safety to the Standard Generalized Markup Language (SGML), and implementing an SGML compliant document management and publishing system. SGML - an international standard (ISO 8879-1986) - is a descriptive markup language that describes a document's structure and purpose, rather than its physical appearance on a page. Significant benefits that will result from UL's use of SGML and these new systems include increased productivity, reduced turnaround times, and data and information consistency, reusability, shareability, and portability. However, the fonts, pagination, and general formatting of UL's new electronic publishing system differ from that of UL's previous publishing system. Consequently, when revision pages are issued for a Standard with the new publishing system, these differences may result in the printing of pages on which no requirements have been changed - these additional pages result from relocation of text due to repagination and reformatting of the Standard with the new publishing system.

Text that has been changed in any manner is marked with a vertical line in the margin. Changes in requirements are marked with a vertical line in the margin and are followed by an effective date note indicating the date of publication or the date on which the changed requirement becomes effective.

The revisions dated January 4, 2000 include a reprinted title page (page1) for this Standard.

The revisions dated April 10, 2000 were issued for editorial corrections. In the set of revisions dated January 4, 2000, an error was introduced by the change of reference from UL 519 to UL 2111, this was corrected with the revisions dated April 10, 2000. Also, these revisions are being issued to correct an incorrect reference to UL 73, the correct reference is UL 2111.

As indicated on the title page (page 1), this UL Standard for Safety is an American National Standard. Attention is directed to the note on the title page of this Standard outlining the procedures to be followed to retain the approved text of this ANSI/UL Standard.

As indicated on the title page (page1), this UL Standard for Safety has been adopted by the Department of Defense.

The master for this Standard at UL's Northbrook Office is the official document insofar as it relates to a UL service and the compliance of a product with respect to the requirements for that product and service, or if there are questions regarding the accuracy of this Standard.

UL's Standards for Safety are copyrighted by UL. Neither a printed copy of a Standard, nor the distribution diskette for a Standard-on-Diskette and the file for the Standard on the distribution diskette should be altered in any way. All of UL's Standards and all copyrights, ownerships, and rights regarding those Standards shall remain the sole and exclusive property of UL.

All rights reserved. No part of this publication may be reproduced, stored in a retrieval system, or transmitted in any form by any means, electronic, mechanical photocopying, recording, or otherwise without prior permission of UL.

Revisions of UL Standards for Safety are issued from time to time. A UL Standard for Safety is current only if it incorporates the most recently adopted revisions.

UL provides this Standard "as is" without warranty of any kind, either expressed or implied, including but not limited to, the implied warranties of merchantability or fitness for any purpose.

In no event will UL be liable for any special, incidental, consequential, indirect or similar damages, including loss of profits, lost savings, loss of data, or any other damages arising out of the use of or the inability to use this Standard, even if UL or an authorized UL representative has been advised of the possibility of such damage. In no event shall UL's liability for any damage ever exceed the price paid for this Standard, regardless of the form of the claim.

UL will attempt to answer support requests concerning electronic versions of its Standards. However, this support service is offered on a reasonable efforts basis only, and UL may not be able to resolve every support request. UL supports the electronic versions of its Standards only if they are used under the conditions and operating systems for which it is intended. UL's support policies may change from time-to-time without notification.

UL reserves the right to change the format, presentation, file types and formats, delivery methods and formats, and the like of both its printed and electronic Standards without prior notice.

Purchasers of the electronic versions of UL's Standards for Safety agree to defend, indemnify, and hold UL harmless from and against any loss, expense, liability, damage, claim, or judgement (including reasonable attorney's fees) resulting from any error or deviation introduced while purchaser is storing an electronic Standard on the purchaser's computer system.

If a single-user version electronic Standard was purchased, one copy of this Standard may be stored on the hard disk of a single personal computer, or on a single LAN file-server or the permanent storage device of a multiple-user computer in such a manner that this Standard may only be accessed by one user at a time and for which there is no possibility of multiple concurrent access.

If a multiple-user version electronic Standard was purchased, one copy of the Standard may be stored on a single LAN file-server, or on the permanent storage device of a multiple-user computer, or on an Intranet server. The number of concurrent users shall not exceed the number of users authorized.

Electronic Standards are intended for on-line use, such as for viewing the requirements of a Standard, conducting a word search, and the like. Only one copy of the Standard may be printed from each single-user version of an electronic Standard. Only one copy of the Standard may be printed for each authorized user of a multiple-user version of an electronic Standard. Because of differences in the computer/software/printer setup used by UL and those of electronic Standards purchasers, the printed copy obtained by a purchaser may not look exactly like the on-line screen view or the printed Standard.

An employee of an organization purchasing a UL Standard can make a copy of the page or pages being viewed for their own fair and/or practical internal use.

The requirements in this Standard are now in effect, except for those paragraphs, sections, tables, figures, and/or other elements of the Standard having future effective dates as indicated in the note following the affected item. The prior text for requirements that have been revised and that have a future effective date are located after the Standard, and are preceded by a "SUPERSEDED REQUIREMENTS" notice.

New product submittals made prior to a specified future effective date will be judged under all of the requirements in this Standard including those requirements with a specified future effective date, unless the applicant specifically requests that the product be judged under the current requirements. However, if

the applicant elects this option, it should be noted that compliance with all the requirements in this Standard will be required as a condition of continued Listing and Follow-Up Services after the effective date, and understanding of this should be signified in writing.

Copyright © 2000 Underwriters Laboratories Inc.

This Standard consists of pages dated as shown in the following checklist:

Page	Date
1-2.....	January 4, 2000
2A.....	April 10, 2000
2B-4.....	January 4, 2000
5-6.....	April 10, 2000
6A.....	January 4, 2000
6B.....	June 2, 1993
7.....	June 1, 1993
8.....	November 4, 1993
9.....	June 1, 1993
10.....	February 18, 1998
10A.....	January 4, 2000
10B-13.....	February 18, 1998
14.....	June 1, 1993
15.....	February 18, 1998
16.....	June 1, 1993
17.....	January 4, 2000
18.....	November 4, 1993
19-20.....	February 18, 1998
21.....	June 1, 1993
22.....	November 4, 1993
23-24.....	February 18, 1998
25.....	April 10, 2000
26-26B.....	January 4, 2000
27-32.....	June 1, 1993
33-34.....	November 4, 1993
35.....	June 1, 1993
36.....	April 10, 2000
36A-36B.....	January 4, 2000
37.....	June 1, 1993
38.....	November 4, 1993
39.....	June 1, 1993
40-42.....	November 4, 1993
43-48.....	June 1, 1993
49-50.....	November 4, 1993
51-54.....	June 1, 1993
55.....	November 4, 1993
56.....	February 18, 1998
56A.....	January 4, 2000
56B.....	February 18, 1998
57-59.....	June 1, 1993
60.....	November 4, 1993
61-63.....	April 10, 2000
64-65.....	June 1, 1993
66.....	November 4, 1993
67.....	June 1, 1993
68.....	November 4, 1993
69-70.....	June 1, 1993
71-74.....	November 4, 1993
75-84.....	June 1, 1993

85-86	January 4, 2000
SA1-SA2	January 4, 2000
SB1.....	August 6, 1996
SB2.....	February 18, 1998
SB3-SB8	August 6, 1996
SB9-SB10	February 18, 1998
SB11-SB16.....	January 4, 2000

No Text on This Page

JUNE 1, 1993
(Title Page Reprinted: January 4, 2000)

1

UL 197

Standard for Commercial Electric Cooking Appliances

First Edition – January, 1952
Second Edition – October, 1960
Third Edition – June, 1972
Fourth Edition – November, 1974
Fifth Edition – April, 1978
Sixth Edition – March, 1982
Seventh Edition – July, 1987

Eighth Edition

June 1, 1993

Approval as an American National Standard (ANSI) covers the numbered paragraphs on pages dated June 1, 1993 . These pages should not be discarded when revised or additional pages are issued if it is desired to retain the ANSI approved text.

An effective date included as a note immediately following certain requirements is one established by Underwriters Laboratories Inc.

Approved as ANSI/UL 197-1980, December 5, 1980
Approved as ANSI/UL 197-1986, September 12, 1986
Approved as ANSI/UL 197-1991, October 18, 1991

The Department of Defense (DoD) has adopted UL 197 on January 28, 1976 . The publication of revised pages or a new edition of this Standard will not invalidate the DoD adoption.

Revisions of this Standard will be made by issuing revised or additional pages bearing their date of issue. A UL Standard is current only if it incorporates the most recently adopted revisions, all of which are itemized on the transmittal notice that accompanies the latest set of revised requirements.

ISBN 1-55989-546-X

COPYRIGHT © 1987, 2000 UNDERWRITERS LABORATORIES INC.

No Text on This Page

CONTENTS

FOREWORD	4
-----------------------	---

INTRODUCTION

1 Scope	5
2 Glossary	5
3 Components	6
4 Units Of Measurement	6

CONSTRUCTION

5 Accessories	6A
6 Frames And Enclosures	7
6.1 General	7
6.2 Openings	8
6.3 Grease troughs and pans	12
7 Accessibility Of Live Parts	13
7.1 General	13
7.2 Protection of service personnel	18
8 Protection Against Corrosion	21
9 Mechanical Assembly	21
9.1 General	21
9.2 Shipping	22
10 Supply Connections	23
10.1 Permanently connected appliances– general	23
10.2 Permanently connected appliances – wiring compartment	24
10.3 Permanently connected appliances – field-wiring terminals and leads	24
10.4 Permanently connected appliances – grounded conductor	26
10.5 Cord-connected appliances – general	26
10.6 Cord-connected appliances – strain relief	28
10.7 Cord-connected appliances – bushings	28
10.8 Cord-connected appliances – grounding	29
11 Grounding And Bonding	29
12 Polarization	31
13 Current-Carrying Parts	31
14 Attachment-Plug Receptacles	32
15 Internal Wiring	32
15.1 General	32
15.2 Insulation	32
15.3 Protection	32
15.4 Splices and connections	33
16 Heating Elements	34
17 Electrical Insulation	35
18 Thermal Insulation	35
19 Motors	36
19.1 General	36
19.2 Motor protection	36
20 Limiting Controls	37
20.1 General	37
20.2 Limiting control for deep-fat fryers	37

21	Short-Circuit And Ground-Fault Protection	37
22	Thermostats and Auxiliary Controls	39
23	Auxiliary-Circuit Terminals	40
24	Capacitors	40
25	Switches	40
26	Lampholders	41
27	Secondary Circuits	42
27.1	General	42
27.2	Limited-energy-secondary circuits	43
28	Spacings	43

PROTECTION AGAINST INJURY TO PERSONS

29	Scope	46
30	General	46
31	Enclosures and Guards	47
32	Materials	48
33	Impact Test	48
34	Switches, Controls, And Interlocks	49
34.1	Switches and controls	49
34.2	Interlocks	49
35	Parts Subject To Pressure	50
35.1	General	50
35.2	Pressure tests	50
35.3	Pressure relief devices	51
36	Stability	52
37	Surface Temperatures	53
38	Warning Markings	54

PERFORMANCE

39	General	55
40	Leakage Current Test	55
41	Power Input Test	57
42	Dielectric Voltage-Withstand Test	57
42.1	General	57
42.2	Secondary Circuits	58
42.3	Transformers	58
43	Enclosure Strength Test	58
44	Resistance To Moisture Test	59
45	Normal Temperature Test	60
45.1	General	60
45.2	Test Equipment	63
45.3	Procedure	64
45.4	Normal test conditions	65
46	Grounding And Bonding Test	68
46.1	Grounding	68
46.2	Bonding	69
47	Strain Relief Test	69
48	Abnormal Heating Test	69
48.1	General	69
48.2	Test Procedure	70
49	Endurance Test	73

49.1 Wiring73
 49.2 Temperature Control73
 50 Motor Switches Test74
 51 Thermal Cutoff Tests74
 52 Transformer Test75
 53 Liquid Containers Test75
 54 Abnormal Operation Test76
 55 Permanence of Marking77

MANUFACTURING AND PRODUCTION TESTS

56 Dielectric Voltage Withstand78
 57 Grounding Continuity78
 58 Limiting Controls79
 59 Pressure Vessels And Parts Subject To Pressure79

RATING

60 Details79

MARKING

61 Visible After Installation80
 62 Visible During Installation And Examination82
 63 Nonpermanent Marking84
 64 Manufacturer’s Literature85

**SUPPLEMENT SA - COMMERCIAL ELECTRIC COOKING APPLIANCES FOR USE UNDER USCG,
 ELECTRICAL ENGINEERING REGULATIONS SUBCHAPTER J (46 CRF, PARTS 110 – 113)**

COOKING APPLIANCES FOR MARINE USE

SA1 ScopeSA1
 SA2 Cleaning and MaintenanceSA1
 SA3 Hinges and Locking DevicesSA1
 SA4 Protection of PersonnelSA1
 SA5 Securing of AppliancesSA2
 SA6 Disconnecting MeansSA2
 SA7 MarkingSA2

**SUPPLEMENT SB - COMMERCIAL ELECTRIC COOKING APPLIANCES WITH RECIRCULATING
 SYSTEMS**

INTRODUCTION

SB1 ScopeSB1

CONSTRUCTION

SB2 Fire Extinguishing System Unit	SB1
SB3 Fire Actuated Damper Assemblies	SB2
SB4 Hood Assembly	SB3
SB5 Hood Materials	SB3
SB6 Hood Air Flow	SB3
SB7 Air Filters	SB4
SB7.1 Electrostatic precipitator	SB4
SB7.2 Interlocks	SB4
SB8 Odor Filters	SB4
SB9 Grease Filters	SB4
SB10 Internal Wiring	SB5
SB11 Blower Motors and Other Electrical Components	SB5
SB12 Power Supply Connections	SB5

PERFORMANCE

SB13 Capture Test	SB5
SB14 Emission Test	SB6
SB14.1 General	SB6
SB14.2 Test apparatus	SB6
SB14.3 Sampling procedure	SB7
SB14.4 Sample handling	SB7
SB14.5 Analysis	SB8
SB14.6 Results	SB9
SB15 Damper Tests	SB9
SB15.1 General <i>Reserved</i>	SB9
SB15.2 Cycling test <i>Reserved</i>	SB9
SB15.3 Closure test	SB9
SB16 Automatic Operation Fire Test	SB9
SB17 Manual Operation Test	SB10
SB18 Fire Containment Test	SB10
SB19 Abnormal Flare Up, Fire, and Burn Out Tests	SB11
SB20 Electrical Tests	SB11
SB21 Ozone Test	SB12
SB22 Gasket and Sealant, Physical and Immersion Tests	SB12
SB22.1 Tensile strength and elongation	SB12
SB22.2 Aging and immersion	SB12
SB22.3 Volume change	SB13
SB23 Fire and Leakage Test of Fittings, Nonwelded Seams, Doors and Panels Used in Grease-Air Stream Enclosures	SB13

MARKING

SB24 Fire Extinguishing System Unit Container	SB14
SB25 Product	SB14

INSTRUCTIONS

SB26 Use and MaintenanceSB15
SB27 Fire Extinguishing System Unit MaintenanceSB15
SB28 Manual Actuation Of Fire Extinguishing System UnitSB15
SB29 Installation InstructionsSB15
SB30 Permanently Attached HoodsSB16

FOREWORD

A. This Standard contains basic requirements for products covered by Underwriters Laboratories Inc. (UL) under its Follow-Up Service for this category within the limitations given below and in the Scope section of this Standard. These requirements are based upon sound engineering principles, research, records of tests and field experience, and an appreciation of the problems of manufacture, installation, and use derived from consultation with and information obtained from manufacturers, users, inspection authorities, and others having specialized experience. They are subject to revision as further experience and investigation may show is necessary or desirable.

B. The observance of the requirements of this Standard by a manufacturer is one of the conditions of the continued coverage of the manufacturer's product.

C. A product which complies with the text of this Standard will not necessarily be judged to comply with the Standard if, when examined and tested, it is found to have other features which impair the level of safety contemplated by these requirements.

D. A product employing materials or having forms of construction which conflict with specific requirements of the Standard cannot be judged to comply with the Standard. A product employing materials or having forms of construction not addressed by this Standard may be examined and tested according to the intent of the requirements and, if found to meet the intent of this Standard, may be judged to comply with the Standard.

E. UL, in performing its functions in accordance with its objectives, does not assume or undertake to discharge any responsibility of the manufacturer or any other party. The opinions and findings of UL represent its professional judgment given with due consideration to the necessary limitations of practical operation and state of the art at the time the Standard is processed. UL shall not be responsible to anyone for the use of or reliance upon this Standard by anyone. UL shall not incur any obligation or liability for damages, including consequential damages, arising out of or in connection with the use, interpretation of, or reliance upon this Standard.

F. Many tests required by the Standards of UL are inherently hazardous and adequate safeguards for personnel and property shall be employed in conducting such tests.

INTRODUCTION

1 Scope

1.1 These requirements cover commercial electric cooking appliances rated 600 volts or less and intended for use in accordance with the National Electrical Code, NFPA-70.

1.2 These requirements cover coffee makers, conductive cookers, food warmers, fryers, griddles, steam kettles, steam cookers, nut warmers, popcorn machines, ranges, utensil warmers, and other appliances usually found in commercial kitchens, restaurants, or other business establishments where food is dispensed.

1.3 These requirements do not cover vending machines, cooking appliances intended for household use, commercial cooking appliances rated more than 600 volts, or microwave cooking appliances.

1.4 An appliance designed so that it can be mounted and supported at an outlet box, such as a food warmer, will be judged on the basis of compliance with the requirements in this standard and with the mounting and weight requirements for electric lighting fixtures.

1.5 An appliance that also utilizes heat produced by a means other than electrical, for example, coal, gas, or oil, is also investigated with respect to such additional risk of fire.

1.6 A product that contains features, characteristics, components, materials, or systems new or different from those covered by the requirements in this standard, and that involves a risk of fire or of electric shock or injury to persons shall be evaluated using appropriate additional component and end-product requirements to maintain the level of safety as originally anticipated by the intent of this standard. A product whose features, characteristics, components, materials, or systems conflict with specific requirements or provisions of this standard does not comply with this standard. Revision of requirements shall be proposed and adopted in conformance with the methods employed for development, revision, and implementation of this standard.

1.6 revised April 10, 2000

2 Glossary

2.1 For the purpose of this standard the following definitions apply.

2.2 CONTINUOUS-DUTY MOTOR – A motor that, under any normal condition of use, can operate unattended and under load for 3 hours or more.

2.3 SAFETY CIRCUIT – A primary or secondary circuit that is relied upon to prevent a risk of fire, electric shock, or injury to persons; for example, an interlock circuit.

2.4 USER SERVICING – Any servicing that might be performed by personnel other than those who are trained to maintain the particular appliance. Some examples of user servicing are:

a) Attaching an accessory by means of an attachment plug and receptacle or by means of other separable connectors.

b) Resetting or replacing any protective device in an appliance, or its receptacle circuit that is likely to be overloaded by the user.

- c) Resetting a circuit breaker or replacing a fuse or a lamp that is accessible without the use of a tool.
- d) Making a routine operating adjustment necessary to adopt the appliance for a different intended function.
- e) Routine cleaning.

3 Components

3.1 Except as indicated in 3.2, a component of a product covered by this standard shall comply with the requirements for that component.

3.1 revised June 2, 1993

3.2 A component is not required to comply with a specific requirement that:

- a) Involves a feature or characteristic not required in the application of the component in the product covered by this standard, or
- b) Is superseded by a requirement in this standard.

3.2 revised April 10, 2000

3.3 A component shall be used in accordance with its rating established for the intended conditions of use.

3.3 revised April 10, 2000

3.4 Specific components are incomplete in construction features or restricted in performance capabilities. Such components are intended for use only under limited conditions, such as certain temperatures not exceeding specified limits, and shall be used only under those specific conditions.

3.4 revised April 10, 2000

4 Units Of Measurement

4.1 Values stated without parentheses are the requirement. Values in parentheses are explanatory or approximate information.

4.1 revised April 10, 2000

CONSTRUCTION

5 Accessories

5.1 An appliance having provisions for the use of an electrical accessory intended to be attached in the field shall comply with the requirements in this standard, with or without an accessory installed.

5.2 Installation of an accessory by the user shall be by means of a receptacle and plug-in connector.

5.3 The installation of an accessory by service personnel shall be by means of receptacles, plug-in connectors, insulated wire connectors, or by connection to existing wiring terminals.

5.4 With reference to 5.3, an installation shall not require the cutting of wiring or the soldering of connections by the installer. Installations shall not require cutting, drilling, or welding in electrical enclosures and in other areas where such operations may damage electrical components and wiring within the enclosure.

5.5 A means for strain relief shall be provided for the wiring in the accessory if there is a possibility of transmitting stress to the terminal connections during installation.

5.6 All terminals and wiring intended to be field connected shall be identified on the accessory, on the appliance if connections are made between the accessory and the appliance, and on the wiring diagram.

5.7 The mounting location of the accessory shall be indicated on the appliance.

Exception: If the mounting location is obvious due to the function of the accessory and arrangement of the appliance, and instructions are provided covering the installation and location for the accessory, the mounting location of the accessory need not be indicated on the appliance.

5.8 As part of the investigation, an accessory is to be trial installed to determine that the installation is feasible, the instructions are detailed and correct, and the use of the accessory does not introduce a risk of electric shock, fire, or injury to persons.

No Text on This Page

6 Frames And Enclosures

6.1 General

6.1.1 An appliance shall be formed and assembled so that it will have the strength and rigidity necessary to resist the abuses to which it is likely to be subjected, without increasing the risk of fire, electric shock, or injury to persons due to total or partial collapse with resulting reduction of spacings, loosening or displacement of parts, or other serious defects.

6.1.2 The enclosure of an appliance shall be of a material acceptable for the application and shall house all electrical parts, except a supply cord, that may present a risk of fire, electric shock, or injury to persons under any condition of use. An adjacent wall or adjacent equipment shall not be depended upon to complete an enclosure.

Exception: A panel that completes an enclosure may be omitted if the enclosure will be completed by another appliance in an adjacent or stacked installation. See 45.3.4 and 64.2.

6.1.3 Among the factors taken into consideration when an enclosure is being judged are its:

- a) Mechanical strength,
- b) Resistance to impact,
- c) Moisture-absorptive properties,
- d) Resistance to combustion,
- e) Resistance to corrosion, and
- f) Resistance to distortion at temperatures to which the enclosure may be subjected under conditions of normal or abnormal use.

For a nonmetallic enclosure, all of these factors are to be considered with respect to thermal aging.

6.1.4 The minimum thickness of cast metal shall be in accordance with Table 6.1.

Exception: Thinner metal that has been found to be acceptable when the enclosure is judged by such factors as those mentioned in 6.1.3.

Table 6.1
Minimum acceptable thickness of cast metal

Metal	Minimum thickness, inch (mm)	
	At reinforced surfaces ^a	At unreinforced flat surfaces
Die-cast metal	3/64 (1.2)	5/64 (2.0)
Cast malleable iron	1/16 (1.6)	3/32 (2.4)
Other cast metal	3/32 (2.4)	1/8 (3.2)
^a Includes surfaces that are curved, ribbed, and the like or are otherwise of a shape or size to provide intended mechanical strength.		

6.1.5 In addition to being considered with reference to the factors mentioned in 6.1.3, an enclosure of sheet metal is judged with respect to its size and shape, the thickness of metal and its acceptability for the particular application. The use of sheet steel having a thickness less than 0.026 inch (0.66 mm) if uncoated or 0.029 inch (0.74 mm) if galvanized, or of nonferrous sheet metal having a thickness of less than 0.036 inch (0.91 mm) is not recommended except for a relatively small area or for a surface that is curved or otherwise reinforced.

6.1.5 revised November 4, 1993

6.1.6 Sheet metal to which a wiring system is to be connected in the field shall have a thickness of not less than 0.032 inch (0.81 mm) if of uncoated steel, of not less than 0.034 inch (0.86 mm) if of galvanized steel, and of not less than 0.045 inch (1.14 mm) if of nonferrous metal.

Exception: Sheet steel not less than 0.026 inch (0.66 mm) thick if uncoated steel or not less than 0.029 inch (0.74 mm) thick if galvanized steel is acceptable if the area surrounding a knockout has a thickness of not less than 0.053 inch (1.35 mm).

6.2 Openings

6.2.1 An opening in the bottom of an appliance shall not be located below an electrical part unless a solid, noncombustible pan complying with Figure 6.1 is interposed between the electrical part and supporting surface. The pan is to have a rim, lip, or other raised edge that is in a horizontal plane and extends all the way around the pan. The bottom of the pan need not be flat or any regular shape and the transmission from the bottom to the rim, lip, and the like may have any convenient shape, but at every point directly below the electrical part, the floor of the pan is to be 1/8 inch (3.2 mm) or more below the plane of the rim, lip, and the like.

Exception No. 1: The requirement does not apply to components on the load side of an automatic switch in a pop-up toaster.

Exception No. 2: The use of a pan of noncombustible material under a motor is not required if:

- a) The motor has no openings below a horizontal plane through the center of the motor;*
- b) The structural parts of the motor or of the appliance provide the equivalent of the described barrier;*

c) The protection provided with the motor is such that no burning insulation or molten material falls to the surface that supports the appliance when the motor is energized under each of the following fault conditions:

1) Open main winding,

2) Open starting winding,

3) Starting switch short-circuited, and

4) For a permanent-split capacitor motor, capacitor short-circuited. The short circuit is to be applied before the motor is energized and the rotor is to be locked;

d) The motor is provided with a thermal motor protector – a protective device that is sensitive to temperature and current – that will prevent the temperature of the motor windings from exceeding 125°C (257°F) at the maximum load under which the motor will run without causing the protector to cycle and from exceeding 150°C (302°F) with the rotor of the motor locked; or

e) The motor is impedance protected and the locked-rotor temperature of the motor winding is not more than 150°C (302°F) with the appliance otherwise operating as intended.

6.2.1 revised November 4, 1993

Figure 6.1
Minimum extent of baffle for opening in bottom of enclosure

Figure 6.1 revised February 18, 1998

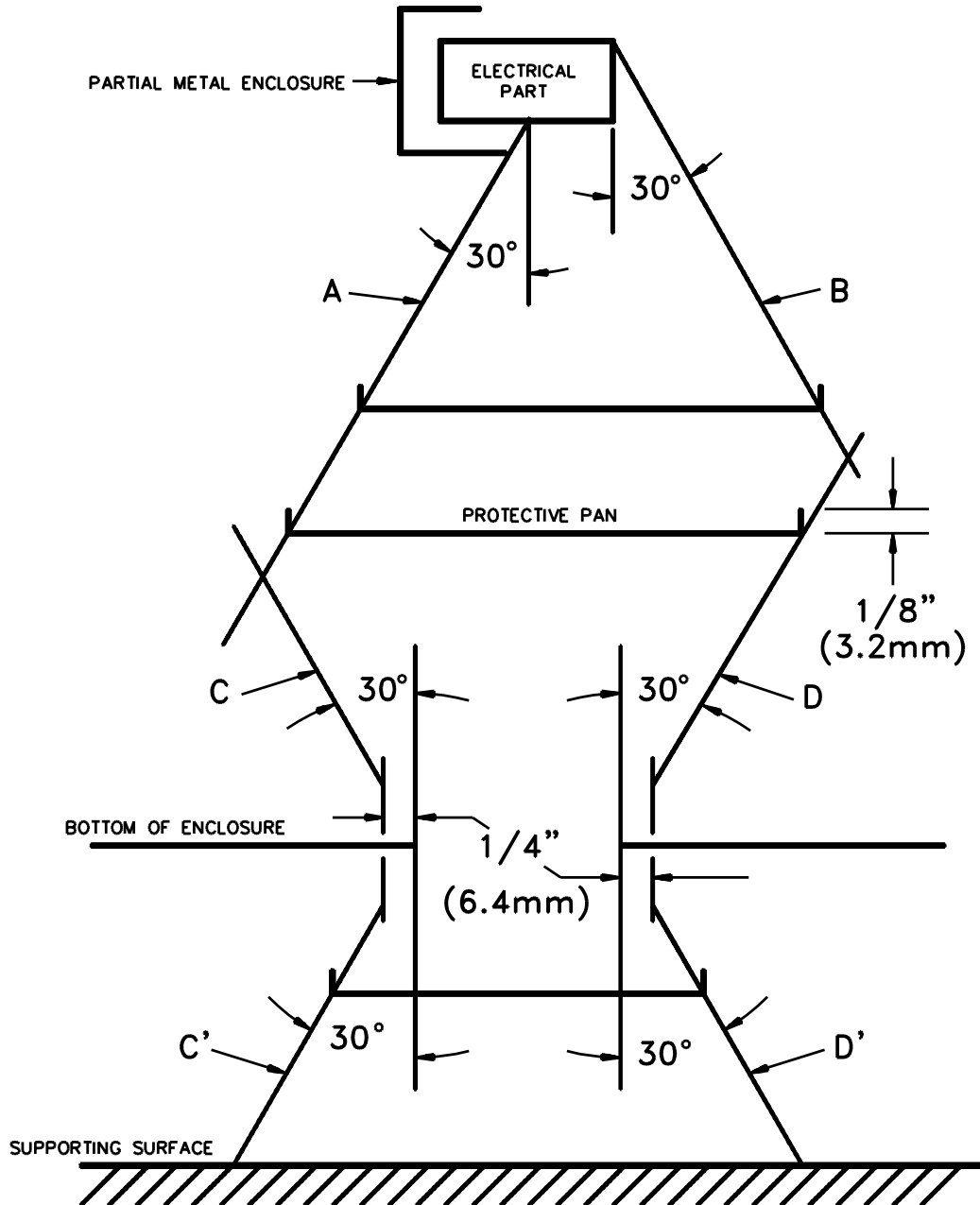

SB0714

A, B, C and D are projections that define a volume between an electrical part and an opening: C' and D' are projections that define a volume between an opening and the supporting surface. A protective pan in any horizontal plane between the part and the opening in the supporting surface must be larger than the area defined by projections A, B, C, and D, or projections C' and D', respectively. Three samples of protective pans are illustrated in the figure, two are above the opening and one is below it.

6.2.2 The structure of the part or of the appliance may provide the equivalent of the pan described in 6.2.1 if it complies with Figure 6.1. The raised edge may be incorporated in the opening.

6.2.3 An opening in a surface other than the bottom of an enclosure that contains electrical parts shall be provided with a baffle, such as the one illustrated in Figure 6.2, that will prevent the emission of flame, molten metal, burning insulation, or the like.

Exception: A baffle may be omitted from an enclosure that contains electrical parts other than an overcurrent-protective device such as a fuse or circuit breaker provided:

- a) The structure of the part provides the equivalent of a baffle,*
- b) The distance from the electrical part to the plane of the enclosure is greater than 12 inches (305 mm), or*
- c) No ventilating opening in a vertical wall is more than 3/8 inch (9.5 mm) wide, and the total area of such openings located less than 12 inches from the floor in any 1-foot-square area of the enclosure does not exceed 8 square inches (52 cm²).*

6.2.4 An opening in the side of an enclosure shall be so located and of such size that entry of foreign objects likely to create a risk of fire or electric shock is prevented and contact with internal parts by persons is prevented. See Accessibility of Live Parts, Section 7 and Enclosures and Guards, Section 31. Louvers may be used if shaped to deflect external falling objects outward. See Figure 6.3.

6.2.5 No opening or joint in the enclosure of an appliance shall be located where spillage from the cooking operation can enter the enclosure and affect the internal wiring or any other electrical component. A removable part, such as a grease pan, shall not be depended upon to provide such protection.

No Text on This Page

Figure 6.2
Relationship of baffle and electrical part to prevent emission

Figure 6.2 revised February 18, 1998

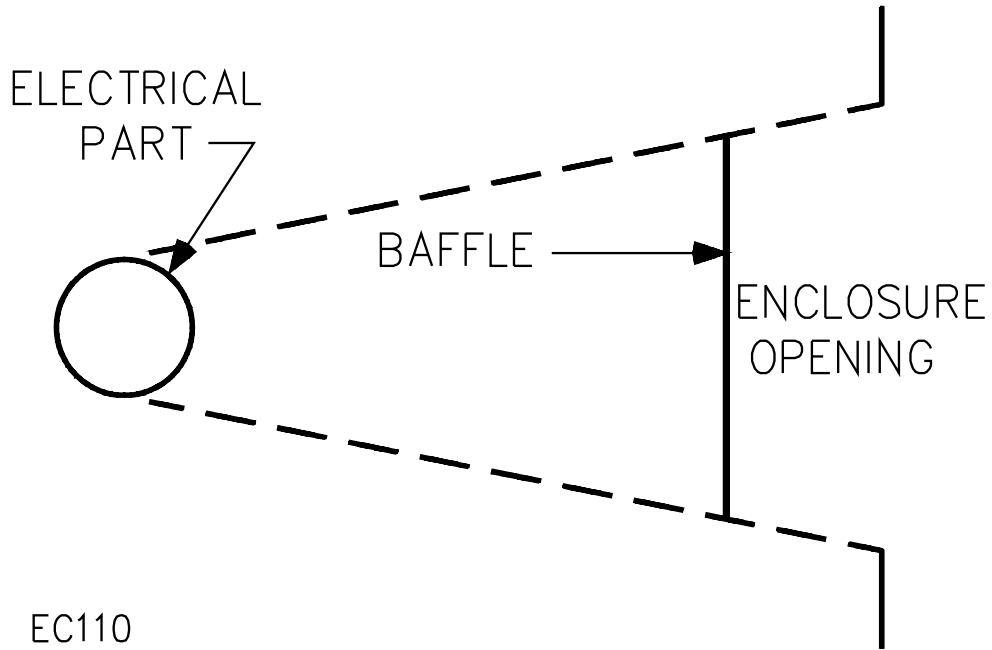
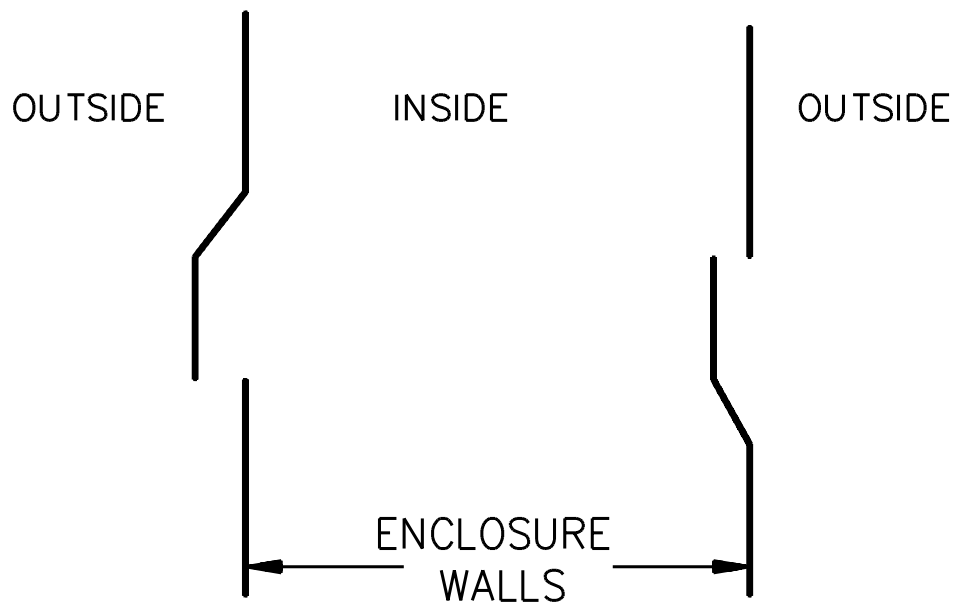

Figure 6.3
Louver designs

Figure 6.3 revised February 18, 1998



SB0716

6.3 Grease troughs and pans

6.3.1 An appliance shall be constructed so that grease spillage is not likely to enter the enclosure and contact live parts or wiring.

6.3.2 An appliance, such as a grill, that has a flat, unenclosed cooking surface and that is intended to be used with grease or oil in the usual cooking operation shall be provided with a trough, grease-collecting pan, or the equivalent to reduce the likelihood of the accumulation of grease on walls, counters, and other nearby surfaces when the appliance is operated.

6.3.3 An opening in the trough of a griddle for drainage to a grease pan or receptacle shall have a drip edge at least 1/2 inch (12.7 mm) long. The opening for the pan or receptacle shall be enclosed on all sides to minimize entrance of grease to the interior of the appliance. Figure 6.4 illustrates some acceptable construction.

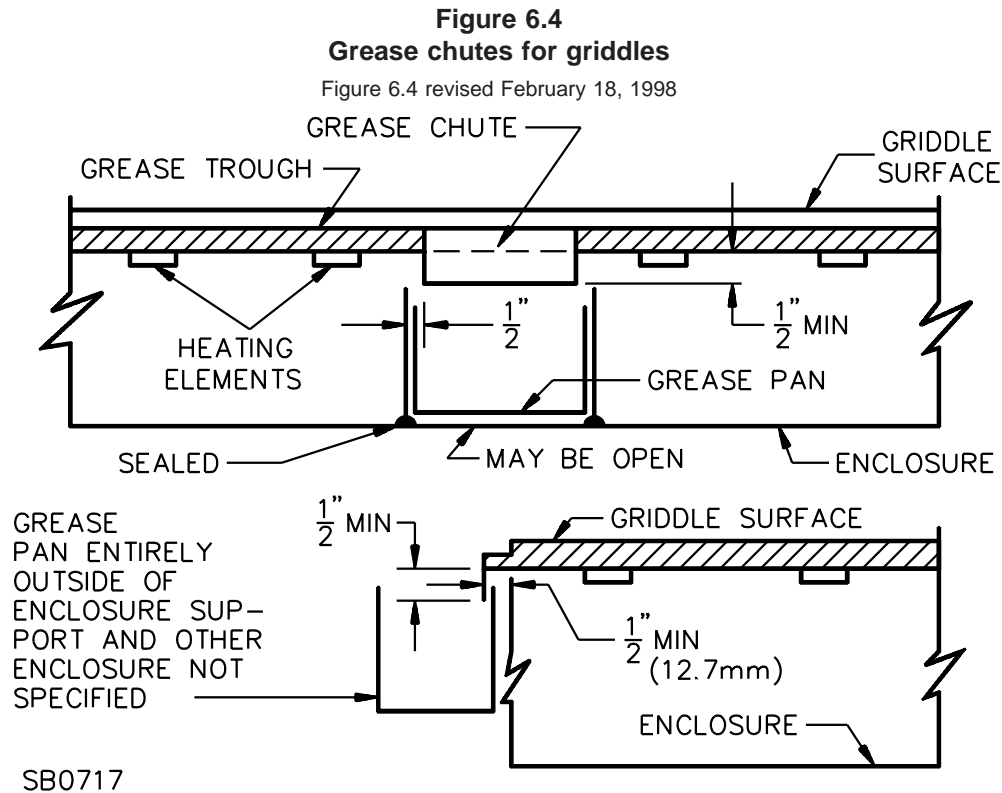

7 Accessibility Of Live Parts

7.1 General

7.1.1 The electrical parts of an appliance shall be located or enclosed so that persons are protected against unintentional contact with uninsulated live parts involving a risk of electric shock.

7.1.2 The risk of electric shock is considered to exist if the available open-circuit potential is more than 42.4 volts peak, and the available current through a 1500-ohm resistance is more than 5 milliamperes.

7.1.3 The following are not considered to be uninsulated live parts: a coil of a controller, a relay, a solenoid, and a transformer, if they are provided with insulating overwraps at least 1/32 inch (0.8 mm) thick; enclosed motor windings; insulated terminals and splices; and insulated wire.

7.1.4 An uninsulated live part, such as a terminal bus bar, and the like, but not including enameled wire, shall not be less than 1 inch (25.4 mm) from any opening in the enclosure of an appliance.

7.1.5 An opening that will not permit the entrance of a 3/4-inch (19.0 mm) diameter rod is acceptable, except as noted in 7.1.4, if a probe as illustrated in Figure 7.1 cannot be made to touch any uninsulated live part or enameled wire when inserted into the opening.

Figure 7.1
Accessibility probe

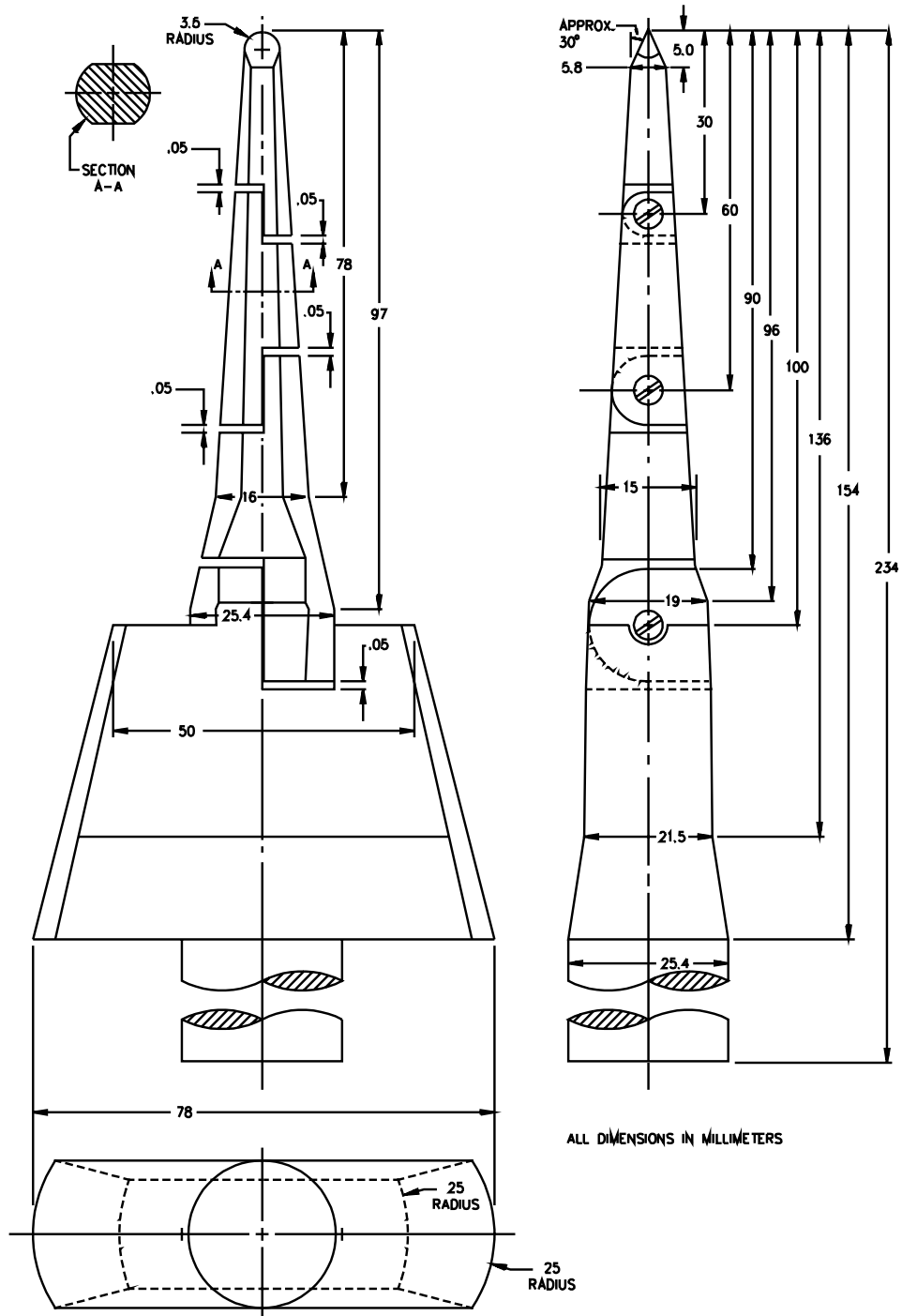

PA100A

7.1.6 An opening that will permit entrance of 3/4-inch (19.0-mm) diameter rod is acceptable if there are no uninsulated live parts:

- a) Less than X inches (mm) from the perimeter of the opening, and
- b) Within the volume generated by projecting the perimeter X inches (mm) normal to its plane – X equals five times the diameter of the largest diameter rod that can be inserted through the opening, but not less than 4 inches (102 mm). See Figure 7.2.

7.1.7 An uninsulated live part shall not be located behind an opening that may be used to make an adjustment considered to be a function of user servicing if a 1/8-inch (3.2-mm) diameter straight rod can be made to touch the part when the rod is inserted through the opening and moved to all positions possible without producing an angle of more than 30 degrees between the rod and the line drawn between the center of the opening and the center of the face of the adjusting mechanism. The length of the rod beyond the opening is not to exceed the distance between the opening and the face of the adjusting mechanism by more than 3 inches (76 mm). See Figure 7.3.

Figure 7.2
Opening in enclosure
Proportions Exaggerated for Clarity
Figure 7.2 revised February 8, 1998

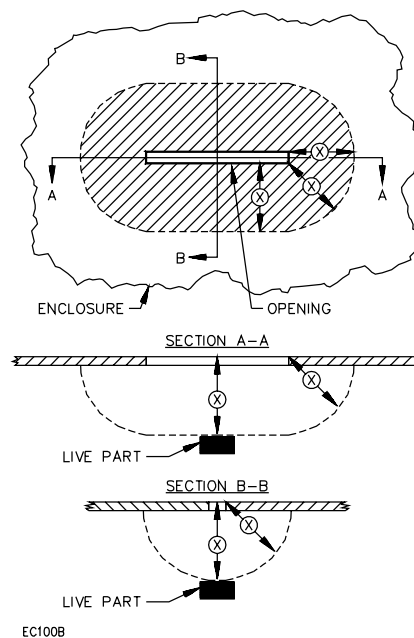
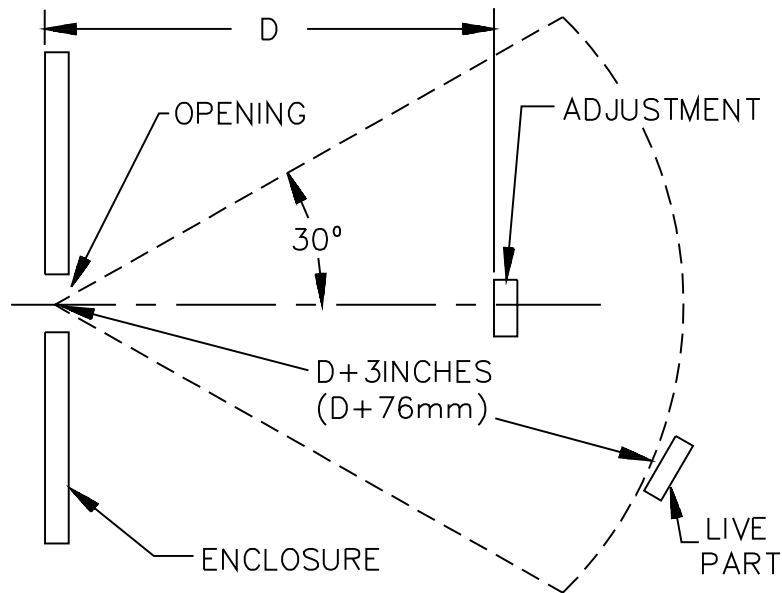

Figure 7.3
Accessibility of live part through adjustment opening



EC120

7.1.8 During the examination of an appliance in connection with the requirements in 7.1.5 – 7.1.7, a part of the outer enclosure that may be removed without the use of tools, or that must be opened or removed for user servicing, is to be disregarded – that is, it will not be assumed that the part in question affords protection against the risk of electric shock. A warning marking such as that specified in 62.13 is not considered to reduce the risk of electric shock.

Exception: The cover of a compartment that does not enclose user-serviceable parts and that is retained in the closed position by means of a keyed lock is to be retained in place while examining the appliance in accordance with 7.1.5 – 7.1.7 if the marking specified in 61.16 is on or adjacent to the cover.

7.1.9 A cover or enclosure of an open-wire element shall not be perforated or otherwise constructed so that complete protection against contact with the element is not provided.

7.1.10 A lamp, a quartz-enclosed heating element, or a similar component shall be installed or guarded so that it is not likely to be broken unintentionally by utensils, such as pans or trays, inserted in an oven or similar compartment.

7.1.11 Except as indicated in 7.1.12, the surface of a component as mentioned in 7.1.10 shall not be contacted when a 3/4-inch (19-mm) diameter rod, 3 inches (76 mm) long and supported vertically, is moved in any direction in a horizontally plane.

7.1.12 If more than one-half of the cylindrical or spherical surface of a lamp is recessed above the plane of the top of a compartment, the remaining lamp surface may be unguarded if no portion projects more than 3/4 inch (19 mm) below the top.

7.1.13 A lens, a shield, or a shade employed as the guard required by 7.1.10 shall not be supported by a lamp, a quartz-enclosed heating element, or a similar component, and shall be made of material that will not be adversely affected by the temperature encountered in normal operation.

7.1.14 The strength of a guard required by 7.1.10 is to be determined by a ball-impact test conducted with a smooth steel sphere having a diameter of 2 inches (50.8 mm) and weighing 1.18 pounds (535 g). If the component being tested can be struck from above, the sphere is to be allowed to fall vertically from rest to strike the component. Otherwise, the sphere is to be suspended by a cord and is to be allowed to fall from rest as a pendulum to strike the component. In either case, the vertical travel of the sphere is to be 51 inches (1.30 m).

7.1.15 A lamp, a quartz-enclosed heating element, or a similar component in a radiant-heat food warmer shall be recessed so that no part of the component extends below the guard or shade.

7.1.16 A lampholder – including one for a quartz-enclosed heating element – a fuseholder, and a circuit breaker shall be located so that a person replacing the lamp or fuse or resetting the circuit breaker cannot unintentionally touch an uninsulated live part.

7.1.17 The requirement in 7.1.16 does not apply to the screw shell or center contact of a screw shell lampholder or a fuseholder or to the clips of a fuseholder or a quartz-enclosed heating element that is associated with the component being replaced. See 62.13.

7.1.18 A fuseholder or a circuit breaker shall not be accessible from outside the appliance without opening a door or a cover.

Exception: The operating handle of a circuit breaker or the insulating cap of an extractor-type fuseholder may project outside the enclosure.

7.1.19 An appliance shall be designed so that fuses can be replaced and manually reset devices reset without removing an enclosure part other than a service cover or panel.

7.1.20 A cover for a compartment that encloses a fuse in a circuit that involves a risk of electric shock – see 7.1.2 – shall be retained in place by hinging, pivoting, sliding, or equivalent means.

7.1.21 The requirements in 7.1.19 and 7.1.20 do not apply to the cap of an extractor type fuseholder or to a cover that covers such a fuseholder cap.

7.1.21 revised January 4, 2000

7.1.22 A cover for a manually reset overload-protective device shall be retained in place by hinging, pivoting, sliding, or equivalent means if it is necessary to open the cover to reset the device and if such opening results in access to live parts. A cover retained by a chain is not considered an equivalent means.

7.1.23 A cover that is required to be hinged shall be provided with a spring latch or catch, spring hinge, or an equivalent means that does not require the use of a tool to hold it closed.

7.1.24 A door or cover giving direct access to a fuse shall shut closely against a 1/4-inch (6.4-mm) rabbet or the equivalent, or shall have either:

- a) Turned flanges for the full length of four edges, or
- b) Angle strips fastened to it.

A flange or an angle strip shall fit closely with the outside of the wall of the box proper and shall overlap the edges of the box not less than 1/2 inch (12.7 mm). A combination of flange and rabbet or other construction that provides equivalent protection is acceptable.

Exception: A door or cover that gives access to a fuse located in a secondary circuit that is not a safety circuit and is supplied from a Class 2 transformer.

7.1.25 A strip used to provide a rabbet and an angle strip fastened to the edges of a door shall be secured:

- a) At not less than two points,
- b) Not more than 1-1/2 inches (38.1 mm) from each end of each strip, and
- c) At points between these end fastenings not more than 6 inches (152 mm) apart.

7.2 Protection of service personnel

7.2.1 An uninsulated live part involving a risk of electric shock and a moving part within the enclosure that involves a risk of injury to persons shall be located, guarded, or enclosed to prevent unintentional contact by service personnel performing mechanical service functions that may have to be performed with the equipment energized.

7.2.1 revised November 4, 1993

7.2.2 Mechanical service functions that may have to be performed with the equipment energized include: adjusting a water-control valve; adjusting the setting of a temperature or a pressure control with or without marked dial settings; resetting a control trip mechanism; operating a manual switch; adjusting an air-flow damper. A factory-set-and-sealed control is not considered to be adjustable.

7.2.3 The requirements in 7.2.1 are not applicable to mechanical service functions that are not usually performed with the equipment energized. Such functions include opening a drain plug, adjusting or replacing a drive belt, and the like.

7.2.4 An adjustable or resettable electrical control or a manual switching device may be located or oriented with respect to uninsulated live parts so that manipulation of the mechanism for adjustment, resetting, or operation can be accomplished in the usual direction of access if uninsulated live parts or moving parts involving a risk of electric shock or injury to persons are:

- a) Not located in front – in the direction of access – of the mechanism, and
- b) Not located within 6 inches (152 mm) on any side or behind the mechanism, unless guarded.

7.2.5 An electrical control component that may require examination, adjustment, servicing, or maintenance while energized, not including measuring voltage, shall be located and mounted with respect to other components and with respect to grounded metal parts so that it is accessible for electrical service functions without subjecting the serviceman to the likelihood of electric shock from adjacent uninsulated live parts or to a risk of injury to persons from adjacent moving parts. See 7.2.9.

7.2.6 Accessibility and protection against the risk of electric shock and injury to persons may be obtained by mounting the control components in an assembly so that unimpeded access to each component is provided through an access cover or a panel in the outer cabinet and the cover of the control assembly enclosure by the following arrangement. See Figure 7.4.

- a) The components are located so that the farthest component in the assembly is not more than 15 inches (381 mm) from the plane of the access opening in the outer cabinet.
- b) Uninsulated live parts outside the control assembly projected clear space – except live parts within a control panel – and unguarded moving parts involving a risk of casualty are located not closer than 6 inches (152 mm) from any side of the access area. The projected clear space is considered to be bounded on the sides by the projection of the smallest rectangular perimeter surrounding the outside edge of the components or the control enclosure when provided. The access area is considered to be bounded on the sides by the projection of the smallest rectangular perimeter surrounding the outside edge of the components or the control enclosure when provided. The access area is considered to be bounded on the sides by the projection of the perimeter of the access opening in the outer cabinet to the closest rectangular perimeter surrounding the outside edge of the component or the control enclosure.
- c) The volume generated by the projected clear space of the control assembly to the access opening in the outer cabinet – within the access area – is completely free of obstructions, including wiring.
- d) Access to the components in the control assembly is not impeded in the direction of access by other components or by wiring in this assembly.
- e) Extractor-type fuseholders and snap switches mounted through the control assembly enclosure are located so that there is unimpeded access to these components through the access opening in the outer cabinet and they are not immediately adjacent to unguarded uninsulated live parts outside the control assembly enclosure. See 7.2.4.

7.2.7 Component or control assemblies that may be rotated or otherwise displaced for service may also be acceptable if the electrical control components are accessible for service as indicated in 7.2.5.

7.2.8 Other arrangements of components or guarding are also acceptable if electrical control components are accessible for service as indicated in 7.2.5.

7.2.9 The electrical components referred to in 7.2.5 – 7.2.8 include: fuses, adjustable or resettable overload relays, manual or magnetic motor controllers, magnetically operated relays, adjustable or resettable pressure or temperature controllers, manual switching devices, and clock timers. Such components in a low-voltage circuit are to comply with the requirements in 7.2.5 with respect to:

- a) Uninsulated live parts in a line-voltage circuit and
- b) Moving parts involving a risk of injury to persons.

Figure 7.4
Accessibility and protection

Figure 7.4 revised February 18, 1998

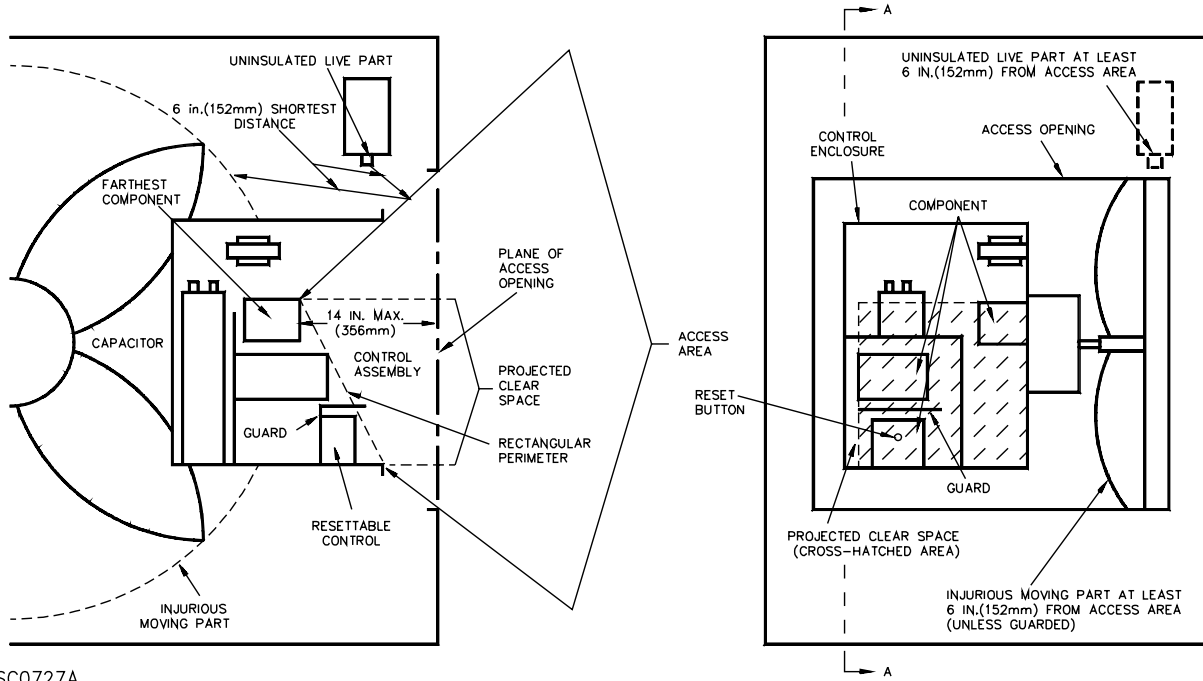

SC0727A

7.2.10 Electrical components in an appliance shall be located so that access for servicing or replacement will not be unduly restricted. It shall not be necessary to remove one electrical part in order to service or replace another.

8 Protection Against Corrosion

8.1 Iron and steel parts shall be protected against corrosion by enameling, galvanizing, plating, or other equivalent means if corrosion of such parts could result in the risk of fire, electric shock, or injury to persons.

Exception No. 1: Surfaces of sheet steel and cast iron parts within an enclosure if the oxidation of iron or steel due to the exposure of the metal to air and moisture is not likely to be appreciable – thickness of metal and temperature also being factors.

Exception No. 2: Bearings, laminations, or minor parts of iron or steel, such as washers, screws, and the like.

Exception No. 3: A sheath of a heating element of other than an immersion-type heater.

9 Mechanical Assembly

9.1 General

9.1.1 An appliance shall be assembled so that it will not be adversely affected by a vibration of normal operation.

9.1.2 A switch, a fuseholder, a lampholder, an attachment-plug receptacle, a motor-attachment plug, or other component that is handled by the user shall be mounted securely and shall be prevented from turning.

Exception: A switch, that meets all four of the following conditions:

- a) The switch is of a plunger, slide, or other type that does not tend to rotate when operated. A toggle switch is considered to be subject to forces that tend to turn the switch during operation of the switch.*
- b) The means of mounting the switch makes it unlikely that operation of the switch will loosen the switch.*
- c) Spacings are not reduced below the minimum acceptable values if the switch rotates.*
- d) Operation of the switch is by mechanical means rather than by direct contact by persons.*

9.1.3 The means to prevent turning required by 9.1.2 is to consist of more than friction between surfaces – for example, a lock washer, properly applied, is acceptable as the means to prevent turning of a device having a single-hole mounting means.

9.1.4 Uninsulated live parts shall be secured to the base or surface so that they will be prevented from turning or shifting in position if such motion may result in a reduction of spacing below the minimum values specified in Spacings, Section 28.

9.2 Shipping

9.2.1 An appliance shall be completely assembled when it leaves the factory.

Exception No. 1: Minor parts, such as handles, decorative trim, pans, trays, splash panels, and the like that are not necessary to prevent a risk of fire, electric shock, or injury to persons during operation of the appliance need not be assembled.

Exception No. 2: A cord set, a heating element with integral blades for plugging into a receptacle, a heating element intended for use in a radiant-heat food warmer, and the legs or the mounting brackets of an appliance – see 63.2 – may be shipped detached from the remainder of the appliance if packed in the same overall carton or if the separate cartons are secured together – such as by steel strapping or strong tape – so that they are not likely to become separated during the shipment.

Exception No. 3: A screw shell heat lamp need not be supplied or shipped with an appliance.

Exception No. 4: A part, as described in (a) or (b), of an appliance marked in accordance with 62.2 and 64.1 need not be completely assembled when shipped, or shipped in the same carton, or shipped in cartons secured together.

a) A panel that completes an enclosure the absence of which would be completely by another appliance in an adjacent or stacked installation. See 45.3.4 and 64.2.

b) An electrical subassembly that does not incorporate an automatic control that is affected, such as by temperature, by the remainder of the appliance, if:

1) Interconnecting leads and wiring are housed entirely within the appliance – see 15.3.1 – 15.3.6 – and the electrical connections are made with integral plugs and receptacles arranged so that no uninsulated live part capable of causing electric shock is accessible to unintentional contact when the subassembly is not in place; or

2) Internal connection of a permanently connected appliance are made in accordance with the requirements for power-supply connections in 10.1 – 10.3 and 62.7, and field-installed leads are housed entirely within the appliance.

3) External connections of a cord-connected appliance are made by a connecting cord, of a type specified in 10.5.1, with integral plugs and receptacles arranged so that no uninsulated live part capable of causing electric shock is accessible to unintentional contact if disconnected; or

4) External connections of a permanently connected appliance are made in armored cable or conduit in accordance with the requirements for power-supply connections in 10.1 – 10.4. See 62.7. If armored cable or conduit is permanently attached to one part of the appliance and stranded leads are installed, the lead ends are to be finished as described in 15.4.6. Solid wire leads need no additional end treatment. The armored cable will be provided with the appropriate connector and antishort bushing. The requirements in this clause are not intended to preclude the use of an external interconnecting cord of a type specified in 10.5.1 if flexible cord is needed for the prevention of transmission of noise or vibration or for facilitating the removal of a part of the appliance for maintenance or repair.

Exception No. 5: A device intended to be mounted separately from a permanently connected appliance, such as a contactor actuated by an automatic control that is part of the appliance, need not be assembled to or shipped with the appliance if marked in accordance with 62.2.

10 Supply Connections

10.1 Permanently connected appliances – general

10.1.1 An appliance intended for permanent connection to the power supply shall be designed so that it can be readily and permanently connected to one of the wiring systems that would be acceptable for the appliance.

10.1.2 An appliance intended for permanent connection to the building structure shall be provided with means for permanent connection to the branch-circuit supply.

Exception: A stationary appliance that is connected to the building structure only by plumbing such as inlet pipes, vent pipes, or drains, is not prohibited from being cord connected when:

- a) *The appliance is rated 125 volts, 20 amps maximum; and*
- b) *The appliance is provided with a type SO, SOO, STO, STOO, SEO, HSO, or HSOO power supply cord with an attachment plug cap and strain relief means.*

10.1.2 revised February 18, 1998

10.1.3 The requirement in 10.1.1 does not apply to an appliance designed to be mounted and supported at an outlet box.

10.1.4 An appliance intended to be built-in or recessed may be provided with 3 – 8 feet (0.9 – 2.4 m) of flexible metal conduit of not less than 1/2-inch electrical trade size, with leads and a grounding conductor installed to facilitate servicing and installation. The flexible conduit need not terminate in an outlet box at the free end but an antishort bushing is to be installed and acceptably retained.

10.1.5 There shall be a flat surface surrounding a knockout. The flat surface shall have an area that permits assembly to the appliance of a length of standard rigid metallic conduit of a size corresponding to the size of the knockout, and shall have a minimum diameter in accordance with Table 10.1.

Table 10.1
Dimensions associated with openings for conduit

Trade size of conduit, inches	Unthreaded openings				Threaded openings			
	Nominal knockout diameter,		Minimum diameter of flat surface at knockout,		Throat diameter, inches (mm)			
	Inches	(mm)	Inches	(mm)	Minimum		Maximum	
1/2	7/8	(22.2)	1.140	(28.96)	0.560	(14.22)	0.622	(15.80)
3/4	1-3/32	(27.8)	1.420	(36.07)	0.742	(18.85)	0.824	(20.93)
1	1-23/64	(34.5)	1.770	(44.96)	0.944	(23.98)	1.049	(26.64)
1-1/4	1-23/32	(43.7)	2.281	(57.94)	1.242	(31.55)	1.380	(35.05)
1-1/2	1-31/32	(50.0)	2.598	(65.99)	1.449	(36.80)	1.610	(40.89)
2	2-15/32	(62.7)	3.175	(80.64)	1.860	(47.24)	2.067	(52.50)
2-1/2	3	(76.2)	3.562	(90.47)	2.222	(56.44)	2.469	(62.71)

10.1.6 The diameter of a knockout shall accommodate conduit of the trade size for which the knockout is intended.

10.2 Permanently connected appliances – wiring compartment

10.2.1 A terminal compartment intended for connection of a supply raceway shall be attached to the appliance so as to be prevented from turning with respect thereto.

10.2.2 A wiring compartment for field-wiring connections shall be of metal and of a volume that will accommodate the wiring of the size indicated in 10.3.2, and conduit and fittings sized for the wire in accordance with the National Electrical Code, NFPA 70-1990.

10.2.3 The location of a terminal box or compartment in which branch-circuit connections to a permanently wired appliance are to be made shall be such that the connections can be inspected without disturbing the wiring or the appliance after the appliance has been installed as intended.

10.2.4 Provision for inspection of connections on the rear or bottom of a floor-mounted appliance is not acceptable except that access can be provided on the rear if the appliance is marked to indicate a spacing of not less than 30 inches (762 mm) in accordance with 61.5. Access is to be judged when the appliance is installed in the test arrangement described in 45.3.3 and if applicable, 45.3.4.

10.2.5 No electrical component shall be mounted on a part that must be removed for the examination of field-wiring connections.

10.2.6 In a terminal box or wiring compartment, the distance between the end of any wire connector or lug and the wall of the enclosure toward which the conductor is directed or through which the connected conductor may pass shall be as specified in Table 10.2.

Table 10.2
Wire bending space at field wiring terminals

AWG	Wire size,		Minimum space, terminal to wall,	
		(mm ²)	inches	(mm) ^a
14 – 10		(2.1 – 5.3)		Not specified
8 – 6		(8.4 – 13.3)	1-1/2	(38.1)
4 – 3		(21.2 – 26.7)	2	(50.8)
2		(33.6)	2-1/2	(63.5)
1		(42.4)	3	(76.2)
1/0, 2/0		(53.5, 67.4)	3-1/2	(88.9)

^a If a conductor is restricted from bending by a barrier or otherwise where it leaves the lug, the distance is to be measured from the end of the barrier.

10.3 Permanently connected appliances – field-wiring terminals and leads

10.3.1 A field-wiring terminal is a terminal to which a supply or other wire can be connected by an installer in the field, unless the wire is provided as part of the appliance and a pressure terminal connector, soldering lug, soldered loop, crimped eyelet, or other means for making the connection is factory-assembled to the wire.

10.3.2 A permanently connected appliance shall be provided with wiring terminals or leads for the connection of conductors having an ampacity not less than 125 percent of the current input of the appliance when connected to a power-supply voltage in accordance with 41.2 or 41.3, whichever would cause the higher input.

Exception: The rating of the wiring terminals or leads may be not less than the rating of the appliance if, when the appliance is operated continuously for at least 3 hours as described for the normal temperature test, the average current input to the appliance is 16 amperes or less; and it is:

- a) Intended for connection to a nominal 120 volts branch circuit;*
- b) Intended to have one or more motors and each motor complies with the requirements for impedance protected motors in the Standard for Overheating Protection for Motors, UL 2111;*
- c) Rated from 16 to 20 amperes when tested under intended conditions; and*
- d) Marked in accordance with 61.11.*

10.3.2 revised April 10, 2000

10.3.3 Pigtail leads provided for connection to the branch-circuit supply shall have an ampacity rating not less than that of a conductor of the next smaller size than that acceptable for the rating of the appliance. See 10.3.4.

10.3.4 It is to be assumed that wire having the specified temperature rating will be installed for the power-supply conductors to an appliance marked in accordance with 62.3 and 62.4. Otherwise, it is to be assumed that 60°C (140°F) wire will be used for connection to an appliance rated 80 amperes or less and that 75°C (167°F) wire will be used for an appliance rated more than 80 amperes.

10.3.5 If terminals of unequal sizes are provided because of unbalanced loads, each terminal shall be sized to accept a conductor having an ampacity of at least 125 percent of the total current that will be carried by the conductor connected to that terminal. See 61.3 and 62.4.

10.3.6 The free length of a lead inside an outlet box or field-wiring compartment shall be 6 inches (152 mm) or more.

Exception: Field-wiring supply connections enclosed in a motor terminal box or wiring compartment.

10.3.7 A field-wiring terminal shall be prevented from turning or shifting in position by means other than friction between surfaces. This may be accomplished by two screws or rivets, by square shoulders or mortises, by a dowel pin, lug or offset, by a connecting strap or clip fitted into an adjacent part, or by some other equivalent method.

10.3.8 A field-wiring terminal shall be provided with a soldering lug or pressure wire connector firmly bolted or held by a screw.

Exception: A wire binding screw may be employed at a wiring terminal intended to accommodate a No. 10 AWG (5.3 mm²) or smaller conductor if upturned lugs, cupped washers or the equivalent are provided to hold the wire in position.

10.3.9 Each upturned lug or cupped washer referred to in the exception to 10.3.8 shall be capable of retaining a power-supply conductor corresponding in size to that specified in 10.3.2, but not smaller than No. 14 AWG (2.1 mm²), under the head of the screw or the washer.

10.3.10 A wire-binding screw at a wiring terminal shall not be smaller than No. 10 (4.8 mm diameter). The threads shall not be finer than that of the national fine thread series for the screw size.

Exception No. 1: A No. 8 (4.2 mm diameter) screw may be used at a terminal intended only for the connection of a No. 14 AWG (2.1 mm²) conductor.

Exception No. 2: A No. 6 (3.5 mm diameter) screw may be used for the connection of a No. 16 or No. 18 AWG (1.3 mm² or 0.8 mm²) control circuit conductor.

10.3.11 It should be noted that No. 14 AWG (2.1 mm²) is the smallest conductor that can be used for branch-circuit wiring and thus is the smallest conductor that is to be anticipated at a terminal for connection of a branch-circuit conductor.

10.3.12 A terminal plate tapped for a wire-binding screw shall be of metal not less than 0.050 inch (1.27 mm) thick.

Exception: A plate may be not less than 0.030 inch (0.76 mm) thick if the tapped threads have acceptable mechanical strength.

10.3.13 There shall not be less than two full threads in the metal of the terminal plate tapped for a wire-binding screw. The metal may be extruded at the tapped hole to provide two full threads.

10.4 Permanently connected appliances – grounded conductor

10.4.1 A permanently connected appliance rated 125 or 125/250 volts (3-wire) or less employing a screw shell lampholder, a single-pole switch, or a single-pole overcurrent-protective device other than an automatic control without a marked off position, shall have one terminal or lead identified for the connection of the grounded conductor of the supply circuit.

10.4.2 A field-wiring terminal intended for the connection of a grounded-supply conductor shall be identified by means of a metallic coating that is substantially white in color and shall be easily distinguishable from the other terminals, or proper identification of the terminal for the connection of the grounded conductor shall be clearly shown in some other manner, such as on an attached wiring diagram.

10.4.3 If wire leads are provided instead of terminals, the surface of the lead intended to be connected to the grounded conductor of the supply circuit shall be finished to show white or natural grey color and shall be easily distinguishable from the other leads.

10.5 Cord-connected appliances – general

10.5.1 A power-supply cord shall be Type SO, SOO, STO, STOO, SEO, SJO, SJOO, SJTO, SJTOO, SJEO, HSO, HSOO, HSJO, HSJOO or Type G No. 1 – 4/0 AWG (42.4 – 107.2 mm²) flexible cable. Type G flexible cable shall employ a suitable attachment plug cap.

Exception No. 1: Type AFS, AFSJ, AFPD, or AFPO cord is acceptable if:

- a) The cord is not more than 4 feet (1.2 m) long,*
- b) The appliance is not likely to be moved frequently after installation, and*

c) The appliance does not employ grease or oil in its normal cooking operation.

No Text on This Page

Exception No. 2: Type HPN cord is acceptable if:

- a) The appliance is intended for counter-top use, and
- b) The weight of the appliance is not more than 15 pounds (6.8 kg).

Exception No. 3: Type W No. 1 – 4/0 AWG (42.4 – 107.2 mm²) flexible cable is acceptable if provided with a grounding conductor.

10.5.2 The length of attached cord or separable cord set shall be within the limits specified in Table 10.3.

Exception: A wall-mounted fixed appliance that must employ cord to permit servicing, such as a wall-mounted coffee maker, may be acceptable if provided with a flexible cord not more than 18 inches (457 mm) long and an attachment plug for supply connection. The investigation of such a feature shall include consideration of the utility of the appliance and the necessity of having it detachable from its source of supply by means of the plug.

Table 10.3
Length of supply cord^a

Type of Appliance		Minimum Acceptable Length,		Maximum Acceptable Length,	
		Feet	(mm)	Feet	(mm)
Counter top or table top	Coffee or other liquid heating appliance with a pouring spout arranged so that to pour the liquid, the unit must be lifted from or tilted with reference to supporting surface	2.0	(610)	3.0	(914)
	All counter top or table top appliances not covered above	2.0	(610)	6.0	(1829)
Floor-mounted		3.0	(914)	10.0	(3048)

^a Applies to an attached cord or a separable cord set.

10.5.3 Where the outer jacket has been removed from Type HSO or HSJO cord the asbestos insulation shall be retained on the individual conductor by a glass string or tape wrap or a close fitting fiber sleeving, or equivalent means acceptable for the temperature. The jacket is not to be removed within the strain relief.

10.5.4 Except as noted in 10.5.5, the current and voltage rating of the cord and the fittings shall not be less than that of the appliance.

10.5.5 The current rating of the attachment plug of an appliance rated more than 15 amperes, shall not be less than 125 percent of the maximum current input of the appliance when tested in accordance with the Power Input Test, Section 41.

Exception: The attachment plug may be rated not less than the current and voltage rating of the appliance if, when operated continuously for at least 3 hours with no food load or as described for the normal temperature test, the average current input to the appliance is 80 percent or less of the ampacity of a branch circuit equal to or higher than the nameplate rating. See marking required in 61.10.

10.5.6 Supplementary insulation employed on a flexible cord shall not extend under the strain relief and shall be prevented from fraying or raveling.

10.5.7 A detachable flatiron or appliance plug of the conventional type shall not be employed for making the power-supply connection to an appliance.

10.6 Cord-connected appliances – strain relief

10.6.1 Strain relief shall be provided so that a mechanical stress on a flexible cord will not be transmitted to terminals, splices, or interior wiring. Means shall be provided for preventing the cord from being pushed into the appliance if such displacement is likely to subject the cord to mechanical damage or to a temperature higher than its rated temperature or can reduce spacings, such as to a metal strain-relief attachment, below the minimum acceptable values.

10.6.2 A knot shall not be employed to provide strain relief.

Exception: A knot in the cord may be used for strain relief at the outlet box end of a cord-suspended appliance, such as a food warmer, if:

- a) A Type SO, SOO, STO, STOO, SEO, SJO, SJOO, SJTO, SJTOO, SJEO, HSO, HSOO, HSJO, or HSJOO cord is used.*
- b) The appliance weighs 10 pounds (4.5 kg) or less, and*
- c) A cross-bar with smooth edges for the cord to bear against is provided.*

10.7 Cord-connected appliances – bushings

10.7.1 At the point where a flexible cord passes through an opening in a wall, barrier, or enclosing case, there shall be a bushing or the equivalent that shall be substantial, acceptably secured in place, and shall have a smooth, rounded surface against which the cord may bear. The heat- and moisture-resistant properties of the bushing material shall be acceptable for the application. A bushing used with Type AFPD, AFPO, or HPN cord shall be of insulating material.

10.7.2 A smooth, rounded cord hole in wood, porcelain, phenolic composition, or other similar nonconductive material is considered to be the equivalent of a bushing.

10.7.3 Ceramic materials and some molded compositions are generally acceptable for insulating bushings; but separate bushings of wood, hot-molded shellac-and-tar compositions, or rubber materials are not acceptable.

10.7.4 Vulcanized fiber may be employed if the bushing is not less than 3/64 inch (1.2 mm) thick and is formed and secured in place so that it will not be adversely affected by conditions of ordinary moisture and temperature.

10.7.5 A separate soft-rubber, neoprene, or polyvinyl chloride bushing may be employed:

- a) Anywhere in an appliance if it is used in conjunction with a type of cord for which an insulating bushing is not required and the edges of a hole in which such a bushing is used is free from burrs, fins, and other conditions that can damage the bushing; or

b) In the frame of a motor or in the enclosure of a capacitor attached to a motor if:

- 1) The bushing is not less than 3/64 inch (1.2 mm) thick, and
- 2) The bushing is located so that it will not be exposed to oil, grease, oil vapor, or other substances that can have a deleterious effect on the compound employed.

10.7.6 An insulated metal grommet may be acceptable in place of an insulating bushing, provided that the insulating material used is not less than 1/32 inch (0.8 mm) thick and completely fills the space between the grommet and the metal in which it is mounted.

10.8 Cord-connected appliances – grounding

10.8.1 The power-supply cord of an appliance shall include a grounding conductor.

10.8.2 The grounding conductor of a flexible cord shall be:

- a) Green with or without one or more yellow stripes;
- b) Connected to the grounding blade of an attachment plug of the grounding type; and
- c) Connected to the enclosure of the appliance by means of a screw not likely to be removed during any servicing not involving the supply cord, or by other acceptable means. Solder alone is not acceptable for making this connection.

11 Grounding And Bonding

11.1 A permanently connected appliance shall be provided with a field-wiring terminal or lead for connection of an equipment-grounding conductor.

11.2 A field-wiring terminal intended solely for connection of an equipment-grounding conductor shall be capable of securing a conductor of the size acceptable for the application. See 11.4.

11.3 The surface of an insulated lead intended for the connection of an equipment-grounding conductor shall be green, with or without one or more yellow stripes, and no other lead shall be so identified.

11.4 A wire binding screw intended for the connection of an equipment-grounding conductor shall have a green colored head that is hexagonal, slotted, or both. A pressure wire connector intended for connection of such a conductor shall be plainly identified as such by being marked "G," "GR," "GND," "Ground," "Grounding" or the like or by a suitable marking on the wiring diagram provided on the appliance.

11.5 The wire binding screw or pressure wire connector intended for the connection of an equipment-grounding conductor shall be located so that it is unlikely to be removed during servicing of the appliance.

11.6 All exposed dead metal parts and all dead metal parts inside the enclosure that are exposed to contact during any servicing operation, including maintenance and repair, and that can become energized shall be electrically connected to the equipment-grounding terminal; and to the metal enclosure surrounding a knockout, hole, or bushing provided for field connection of the power supply system; or to the grounding conductor of a supply cord.

11.7 With reference to the requirements in 11.6, the following dead metal parts are not considered to be parts that can become energized.

- a) A small metal part, such as an adhesive-attached foil marking, screw, handle, and the like that is:
 - 1) On the exterior of the enclosure and separated from all electrical components by grounded metal, or
 - 2) Positively separated from all electrical components.
- b) A panel or a cover that is insulated from all electrical components by a barrier of vulcanized fiber, varnished cloth, phenolic composition, or other moisture-resistant insulating material not less than 1/32 inch (0.8 mm) thick and reliably secured in place.
- c) A panel or a cover that does not enclose uninsulated live parts and is positively separated from other electrical components.
- d) A core and assembly screws of a relay, a solenoid, and the like.

11.8 The dead metal parts described in 11.6 shall be reliably bonded together by mechanical fasteners or by an individual bonding conductor or strap.

11.9 Bonding shall be by a positive means, such as clamping, riveting, bolted or screwed connections, brazing, or welding. The bonding connection shall penetrate nonconductive coatings such as paint.

11.10 Bonding around a resilient mounting shall not depend on the clamping action of rubber or similar material.

Exception: The clamping action of rubber or similar material may be depended upon if the construction has been shown by investigation to be acceptable for the purpose. This investigation may include such tests as overload, short-circuit, and aging.

11.11 A bonding conductor shall be of material complying with the requirements for an electrical conductor and protected from corrosion unless inherently resistant thereto. An individual bonding conductor or strap shall be installed so that it is protected from mechanical damage.

11.12 Bonding conductors or straps used to provide grounding continuity between stacked ovens may be applied in the field if marking is provided in accordance with 62.7.

11.13 The size of an individual conductor or strap employed to bond an electrical enclosure or motor frame shall be determined by the rating of the overcurrent-protective device of the branch circuit to which the equipment will be connected in accordance with Table 250-95 of the National Electrical Code, NFPA 70-1990.

Exception No. 1: A bonding conductor to a motor is not required to be larger than the motor-circuit conductors.

Exception No. 2: A conductor smaller than that specified in Table 250-955 may be used if the bonding connection does not open when tested as described in 46.2.1.

11.14 If more than one size branch-circuit overcurrent device is involved, the size of the bonding conductor shall be based on the rating of the overcurrent-protective device intended to provide ground-fault protection for the component bonded by the conductor. For example, the size of a bonding conductor for a motor that is individually protected by a branch-circuit overcurrent device smaller than the overcurrent devices protecting the overall equipment, may be selected on the basis of the overcurrent device intended for ground-fault protection of the motor.

11.15 The resistance shall not be more than 0.1 ohm between any point required to be grounded, as mentioned in 11.6, and:

- a) The equipment-grounding conductor terminal in the case of an appliance intended for permanent electrical connection, or
- b) The point to which the grounding conductor of the power-supply cord is connected.

11.16 Exposed dead metal parts that can become energized but are not secured to the remainder of the appliance, such as a griddle plate, shall be electrically connected to the appliance frame. A separate, stranded, grounding wire, not smaller than No. 14 AWG (2.1 mm²), shall be used unless the part weighs 50 pounds (22.7 kg) or more. For a part weighing 50 pounds or more, the grounding wire described above shall be provided or the part shall be supported by sharp edges or by one or more sharp-pointed leveling screws. If sharp edges or leveling screws are depended upon for grounding, the supporting surface shall not be painted, enameled, or otherwise treated to result in a high-resistance connection between the frame and the exposed dead metal part.

11.17 Upon insertion of a removable heating element or other removable part, the grounding connection shall be made before any other electrical connection, and, upon removal, the grounding connection shall be broken after the electrical connection.

Exception: A soup warming cup with an insulating handle and a shield between the handle and cup, if the cup is constructed so that contact between the metal cup and a grounded metal stand will be provided when the cup is inserted into the receptacle in a direction parallel to the terminal pins of the cup.

12 Polarization

12.1 If an appliance is connected to a circuit that incorporates a grounded neutral conductor, the screw shells of lampholders shall be connected:

- a) For a permanently connected appliance, to the conductor or terminal intended to be grounded; or
- b) For a cord-connected appliance, to the conductor of the supply cord intended to be grounded.

12.2 If there is no grounded conductor, as mentioned in 12.1 and if two lampholders are connected in series, the lampholder screw shells shall be common and the center contacts of the lampholders shall be connected toward the supply.

12.3 A fuseholder, a single-pole switch, a single-pole overcurrent-protective device or an automatic control with a marked off position shall be connected to an ungrounded conductor of the supply circuit.

13 Current-Carrying Parts

13.1 The metal employed for a current-carrying part shall be acceptable for the particular application.

13.2 Plated iron or steel may be used for a current-carrying part the temperature of which is higher than 100°C (212°F) during normal operation.

13.3 Unplated iron or steel may be used only for a terminal rod or a terminal plate of a heating element.

13.4 Stainless steel and other corrosion-resistant alloys may be used for current-carrying parts regardless of temperature.

14 Attachment-Plug Receptacles

14.1 A 15- or 20-ampere attachment-plug receptacle intended for general use shall be of the grounding type. The grounding contact of the receptacle shall be connected to the point of connection of the equipment-grounding conductor to the appliance.

14.2 The face of a receptacle shall:

- a) Be flush with or project beyond a nonconductive surrounding surface, or
- b) Project at least 0.015 inch (0.38 mm) beyond a conductive surrounding surface.

15 Internal Wiring

15.1 General

15.1.1 Wire employed for the internal wiring of an appliance shall be acceptable for the application.

15.1.2 Among the factors considered when judging the internal wiring are the temperature and voltage to which it may be subjected during normal operation.

15.2 Insulation

15.2.1 There is no temperature limit applicable to unimpregnated asbestos, glass fiber, beads of inorganic material, or the equivalent, employed as conductor insulation but asbestos insulation shall not be used where exposed to moisture produced by the appliance.

15.2.2 The wall thickness of insulation on internal wiring shall not be less than 0.028 inch (0.71 mm).

Exception No. 1: Secondary circuits not required to be investigated in accordance with 27.1.1.

Exception No. 2: The thickness of cross-linked synthetic polymer, polytetrafluoroethylene or fluorinated ethylene propylene insulation may be not less than 0.015 inch (0.38 mm).

15.3 Protection

15.3.1 The wiring and electrical connections between parts of an appliance shall be protected or enclosed, except that a length of flexible cord of a type specified in 10.5.1 may be employed for external connections between parts if flexibility is essential. See 15.3.6. Wiring and connections in circuits other than those covered in 27.1.1 shall not be subject to handling during user servicing.

15.3.2 With reference to exposure of internal wiring, the protection of wiring required by 15.3.1 is considered to exist, if, when judged as if it were enameled wire, the wiring would be acceptable according to 7.1.4 – 7.1.8.

15.3.3 Internal wiring not so protected may be acceptable if it is secured within the enclosure so that neither it nor related electrical connections can be subjected to stress or mechanical damage. All wiring that is accessible to the operator is to be clamped or otherwise secured to prevent it from being unintentionally hooked, or the like.

15.3.4 No wiring shall be located where it must be moved to replace a fuse, operate a circuit-breaker handle, or adjust a manually reset control.

15.3.5 No open wiring – that is wiring that is not separately and immediately enclosed in conduit, armored cable, metal raceway, or the like – shall be located where it is likely to be contacted during operator servicing or cleaning.

Exception: Wiring to a surface element that may be contacted by the user or operator during user servicing provided the wiring is acceptably secured to the panel in which the element is mounted.

15.3.6 Internal wiring to a surface element is considered to be protected if it is routed and secured so that the wiring will return to its intended position following any movement associated with a user servicing operation involving the surface elements. See 49.1.1 and 49.1.2.

15.3.7 The insulation of internal wiring that is likely to be subjected to accumulations of oil or grease, such as that of a deep-fat fryer or griddle, shall be a type that will not be adversely affected under such conditions.

15.3.8 Wiring shall be protected from sharp edges, including screw threads, burrs, fins, moving parts, and the like that may abrade the insulation on conductors or otherwise damage the wiring.

15.3.9 An appliance shall be designed so that wires can be pulled through, or the appliance otherwise wired, without damaging the coverings or insulation on the conductors.

15.3.10 A wireway shall be free from burrs and fins. Male screw threads shall not be exposed anywhere inside a raceway or wireway where wire is pulled.

15.3.11 Internal wiring shall be located so that it will not be exposed to the vapors from a vented oven of an appliance.

15.3.12 A conductor utilizing beads for insulation shall not be employed outside an enclosure.

15.3.13 A hole through which insulated wires pass in a sheet-metal wall within the overall enclosure of the appliance, shall be provided with a smooth, rounded bushing, or shall have smooth surfaces upon which the wires may bear to prevent abrasion of the insulation.

15.3.14 A flexible cord used for external interconnection as mentioned in 15.3.1 shall be provided with bushings and strain relief in accordance with 10.6 and 10.7 unless the construction is such that the cord will be protected from stress or motion.

15.3.14 revised November 4, 1993

15.3.15 Insulated wires may be bunched and passed through a single opening in a metal wall within the enclosure of the appliance.

15.4 Splices and connections

15.4.1 A splice and a connection shall be mechanically secure and shall provide electrical contact. A soldered connection shall be mechanically secured before being soldered if breaking or loosening of the connection may result in a risk of fire or electric shock.

15.4.2 Flexing or movement of internal wiring that occurs during the cooking or cleaning function shall not cause stress on any electrical connection.

15.4.3 A splice shall be provided with insulation equivalent to that on the wires involved.

Exception: The requirement does not apply if permanence of spacing between the splice and other metal parts of the appliance will be maintained.

15.4.4 In determining whether splice insulation consisting of coated-fabric, thermoplastic, or other tubing is acceptable, consideration is to be given to such factors as its dielectric properties, heat-resistance and moisture-resistance. Thermoplastic tape wrapped over a sharp edge is not acceptable.

15.4.4 revised November 4, 1993

15.4.5 Stranded internal wiring shall be connected to a wire-binding screw or stud-terminal so that no loose strands result.

15.4.6 Compliance with the requirement in 15.4.5 can be accomplished by:

- a) Use of pressure terminal connectors, soldering lugs, or crimped eyelets;
- b) Soldering all strands of the wire together; or
- c) Equivalent means.

15.4.7 Aluminum conductors, insulated or uninsulated, used as internal wiring, such as for interconnection between current-carrying parts or as motor windings, shall be terminated at each end by a method that is acceptable for the combination of metals involved at the connection point.

15.4.8 With reference to 15.4.7, a wire-binding screw or a pressure terminal connector, or other type of connector used as a termination device shall be investigated and found acceptable for use with aluminum under the conditions involved – for example, temperature, heat cycling, vibration, and the like.

16 Heating Elements

16.1 A heating element shall be supported in a substantial and acceptable manner.

16.2 A movable heating element shall be protected against damage caused by contact with other parts of the appliance when the element is moved.

16.3 An exposed open-wire element in an appliance shall not be accessible to contact by the user.

Exception No. 1: A toaster designed for operation on a circuit involving a potential to ground of 250 volts or less.

Exception No. 2: The rotating head of a cotton-candy maker designed to rotate at 3000 revolutions per minute or more provided the heating element can only be contacted through the opening into which sugar is poured.

16.4 An appliance in which the heating element is designed for operation only in an air blast shall be wired or controlled so that the element can be operated only when under the cooling effect of the blast. An appliance in which the cooling effect of the motion of a part is necessary to prevent excessive temperature shall be wired or controlled so that the heating element cannot be operated in the absence of such motion.

16.5 The sheath employed to enclose a heating element of an immersion heater shall be of a metal resistant to corrosion by the liquid in which the heater is intended to be immersed.

16.6 The marked voltage rating of a heating element shall not be less than the voltage rating of the circuit in which the heating element is connected.

Exception No. 1: A heating element having a marked voltage within an applicable range of voltages specified in 60.2 is acceptable if the voltage rating of the appliance is within that range.

Exception No. 2: The marked voltage of an element that is connected in series is to be compared with the applied voltage.

17 Electrical Insulation

17.1 An insulating washer, a bushing, a lining, a barrier, or the like, that are integral parts of an appliance, and a base or a support for the mounting of live parts shall be of a moisture-resistant material that will not be adversely affected by the temperatures to which it will be subject under conditions of actual use.

17.2 Insulating material is to be judged with respect to its acceptability for the particular application. Materials such as mica, some molded compounds, and certain refractory materials are usually acceptable for use as the sole support of live parts.

17.3 Some materials that are not acceptable for general use, such as magnesium oxide, may be acceptable if used in conjunction with other acceptable insulating materials or if located and protected so that mechanical damage is prevented and the absorption of moisture is minimized.

17.4 When it is necessary to investigate a material to determine whether it is acceptable, consideration is to be given to its mechanical strength, dielectric properties, insulation resistance, heat-resistant qualities, the degree to which it is enclosed or protected, and any other features having a bearing on the risk of fire, electric shock, or injury to persons involved in conjunction with conditions of actual service. All of these factors are to be considered with respect to thermal aging.

17.5 Screws or other fasteners used to mount or support small, fragile, insulating parts, shall not be so tight as to crack or break such parts with expansion and contraction. Generally, such parts should be slightly loose.

18 Thermal Insulation

18.1 Thermal insulating material shall be acceptable for the application.

18.2 Combustible or electrically conductive thermal insulation shall not contact uninsulated live parts of the appliance.

18.3 Mineral-wool thermal insulation that contains conductive impurities in the form of slag shall not contact uninsulated live parts.

18.4 A material of asbestos composition shall not be used where it will be exposed to cooking utensils or food, such as in an oven or between a storage drawer and the bottom liner of the oven, if the asbestos composition is such that fibers may be separated from the base material.

19 Motors

19.1 General

19.1.1 A motor shall be acceptable for the particular application and shall be capable of handling its maximum normal load without creating a risk of fire, electric shock, or injury to persons.

19.1.2 A motor winding shall resist the absorption of moisture and shall be formed and assembled in a workmanlike manner.

19.1.3 With reference to the requirement in 19.1.2, enameled wire need not be additionally treated to prevent absorption of moisture, but fiber slot liners, cloth coil wrap, and similar moisture-absorbent materials shall be impregnated or otherwise treated to prevent moisture absorption.

19.1.4 The diameter of the motor is the diameter, measured in the plane of the laminations, of the circle circumscribing the stator frame, excluding lugs, fins, boxes, and the like used solely for motor mounting, cooling, assembly, or connection.

19.2 Motor protection

19.2.1 A continuous-duty motor in a permanently connected appliance, an automatically controlled fractional-horsepower motor in an appliance, the motor of an appliance intended to be operated remotely or unattended, a motor the operation of which or inability to operate will not be evident to the operator, and a continuous-duty integral-horsepower motor shall be provided with one of the following types of overload protection:

- a) Thermal and impedance protection complying with the requirements in the Standard for Overheating Protection for Motors, UL 2111.
- b) Other protection that tests show is equivalent to the protection mentioned in (a).

Exception: A motor that is used for a direct-drive blower or fan is considered to have acceptable overload protection if it is protected against locked-rotor conditions only.

19.2.1 revised April 10, 2000

19.2.2 An automatically controlled appliance is an appliance in which:

- a) Energization of a motor, solenoid, magnet, or the like will occur without manual intervention, or
- b) During any single predetermined cycle of operation, automatic changing of the mechanical load can reduce the speed of a motor sufficiently to reestablish starting-winding connections to the branch circuit.

19.2.3 A remotely controlled appliance is an appliance that is out of sight of an operator who is at the starting device.

19.2.4 Fuses may be used to provide the necessary overcurrent protection if compliance with the requirements will be provided by the largest ampere-rated fuse that can be mounted in the fuseholder or if a noninterchangeable fuse is used. The fuse used to provide this protection need not be suitable for branch-circuit protection.

No Text on This Page

20 Limiting Controls

20.1 General

20.1.1 A thermal cutoff shall be acceptably secured in place.

20.1.2 A thermal cutoff that is depended upon to reduce the risk of overheating of an appliance during abnormal operation shall comply with the requirements in the Standard for Thermal Cutoffs for Use in Electrical Appliances and Components, UL 1020, in addition to the requirements specified in this standard. The operation of a thermal cutoff shall not involve a risk of fire or electric shock as described in 48.1.3 and 48.1.4.

20.1.3 If malfunction of a combination temperature-regulating and -limiting control for a heating element could result in a risk of fire or electric shock – as described in 48.1.3 and 48.1.4 – due to overheating of the appliance, a back-up protective device shall be provided to limit temperature.

20.1.4 With reference to 20.1.3, each control shall be considered individually in an appliance employing more than one separately controlled heating element.

20.2 Limiting control for deep-fat fryers

20.2.1 A deep-fat fryer shall incorporate a nonadjustable limiting control that interrupts power to the heating element or elements before the oil exceeds a temperature 246°C (475°F). See 45.4.9 and 45.4.10. The calibration means of the control shall be sealed and the control shall comply with the calibration requirements for temperature-limiting controls.

20.2.2 The temperature-limiting-control circuit shall be separate from the temperature-regulating-control circuit so that malfunction of any component in one circuit will not adversely affect the operation of the other circuit.

20.2.3 A contactor that is part of a temperature-limiting-control circuit shall operate each time the fryer is turned on or off, but not during normal operation of the appliance.

20.2.4 If an automatically reset limiting control is used, the fryer shall incorporate a signal lamp that complies with the requirement in 25.9 to indicate when the limiting control is functioning.

20.2.5 Opening of either a grounded or an ungrounded conductor of the supply circuit that renders a limiting-control circuit inoperative shall also cause interruption of current through the heating elements.

20.2.6 A switch provided to test a limiting control shall be:

- a) A momentary contact switch,
- b) Provided with adjacent marking in accordance with 61.15, and
- c) Tested in accordance with 49.2.1.

21 Short-Circuit And Ground-Fault Protection

21.1 The overcurrent protection specified in 21.5 – 21.10 shall be located in each ungrounded conductor, and shall comply with the requirements for branch-circuit protection.

21.2 A fuse used for the overcurrent protection referred to in 21.1 shall be a Class CC, G, H, J, K, L, RK, or T cartridge fuse, a Type S, an Edison-base plug fuse, or the equivalent.

21.3 The screw shell of a plug fuseholder and the accessible contact of an extractor fuseholder shall be connected toward the load.

21.4 It will be assumed that the rating of the branch-circuit overcurrent-protective device will be 150 percent of the rating of the appliance unless the appliance is marked to specify the use of a protective device having a lower rating. Standard ampere ratings for overcurrent-protective devices are 15, 20, 25, 30, 35, 40, 45, 50, 60, 70, 80, 90, 100, 110, 125, 150, 175, and 200. If 150 percent of the rating of the appliance does not equal one of the standard overcurrent-protective device ratings mentioned above, it will be assumed that the next lower rating or setting of overcurrent-protective device will be employed.

21.5 An appliance provided with auxiliary-circuit terminals shall incorporate an overcurrent-protective device in accordance with 21.1 in each ungrounded conductor to the terminals.

Exception: An overcurrent-protective device is not required as a part of the appliance if it is determined that equivalent or better protection will be obtained from the branch-circuit overcurrent-protective device through which the appliance will be supplied.

21.6 A motor or transformer in an appliance rated more than 16 amperes shall be protected by an overcurrent-protective device incorporated in the appliance. The overcurrent-protective device shall have a maximum ampere rating in accordance with the National Electrical Code, ANSI/NFPA 70-1990.

Exception No. 1: An overcurrent-protective device is not required as a part of the appliance if it is determined that equivalent or better protection will be obtained from the branch-circuit overcurrent-protective device through which the appliance will be supplied.

Exception No. 2: The overcurrent protection may be omitted from the primary of a Class 2 transformer, and may be omitted from the primary of any other transformer if the transformer complies with the requirements in 52.1.

Exception No. 3: A motor having an inherent thermal protector that complies with the requirements of such devices does not require an additional overcurrent-protective device if, in the appliance, it will be connected in series with a branch-circuit overcurrent-protective device of the same type and having a current rating equal to or less than that with which the motor-protector combination was tested during the investigation of the protector.

Exception No. 4: An overcurrent-protective device is not required for an appliance that complies with the exceptions to 10.3.2 and 10.5.5.

21.7 Each lampholder circuit in a permanently connected appliance having a lampholder independent of any heating-element circuit shall have overcurrent protection rated not more than 20 amperes in the appliance, if the overcurrent protection of a branch circuit to which the appliance may be properly connected in accordance with 21.4 will not be adequate for the lampholder.

21.7 revised November 4, 1993

21.8 An attachment-plug receptacle intended for general use shall have overcurrent protection rated not more than 20 amperes in the appliance unless the appliance would be properly connected, in accordance with 21.4, to a branch circuit rated 20 amperes or less.

21.9 An appliance employing resistive heating elements rated more than 48 amperes shall have the heating elements on subdivided circuits. The load on each circuit shall not exceed 48 amperes, and each circuit shall be protected at not more than 60 amperes unless required to be protected at a lower level in accordance with 21.10. The protective device shall be:

- a) Factory installed within or on the appliance enclosure, or
- b) Provided as a separate assembly by the appliance manufacturer.

Exception: An appliance using sheathed heating elements may be subdivided into circuits not exceeding 120 amperes and protected at not more than 150 amperes if:

- a) The elements are integral with and enclosed within a cooking surface.*
- b) The elements are completely contained within an enclosure acceptable for the purpose, or*
- c) The elements are contained within an ASME rated and stamped vessel.*

21.10 Exposed metallic-sheathed heating elements intended for direct contact with cooking utensils shall have overcurrent protection rated not more than 50 amperes in the appliance unless the appliance would be properly connected in accordance with 21.4 to a branch circuit rated 50 amperes or less.

22 Thermostats and Auxiliary Controls

22.1 A manually reset thermostat shall be capable of being reset:

- a) From outside the appliance, or
- b) After opening a hinged door or the equivalent that does not give access to uninsulated live parts.

Exception: If marked in accordance with 62.13.

22.2 The reset button of a manually reset thermostat shall be protected from mechanical abuse.

22.3 If a thermostat in fixed or stationary equipment has a marked off position, when the thermostat is set to the off position:

- a) Lowering of temperature or loss of capillary tube pressure shall not cause the contacts to close and
- b) The heating element circuit shall not produce heat.

"No heat," "Cold," or the like are considered to be off markings.

22.4 The bulb and capillary tubing of a thermostat of an appliance shall be located or shielded so as to be protected from mechanical damage.

22.5 A temperature control shall have a rating suitable for the load it controls.

22.6 An auxiliary control device, such as provided in an automatic toaster, shall disconnect the element or elements that it controls from all conductors of the power-supply circuit unless there will be no live parts exposed to unintentional contact when the auxiliary control device is open.

22.7 An auxiliary control is considered to be one that is intended primarily for time, temperature, or pressure regulation, and the like under conditions of normal operation, and not for protection against overload or excess-temperature conditions resulting from abnormal operation.

23 Auxiliary-Circuit Terminals

23.1 Auxiliary-circuit terminals are terminals that can be electrically connected to a fire-extinguishing system for the purpose of interrupting the coil circuit of the contactor used to control the source of heat in the appliance.

23.2 Auxiliary-circuit terminals shall comply with the requirements for field-wiring terminals. See 10.3 – 10.4.

23.2 revised November 4, 1993

23.3 Auxiliary-circuit terminals shall be connected to:

- a) A contactor that complies with the requirement in 49.2.1 for a combination temperature-regulating and -limiting control,
- b) A shunt-trip circuit breaker, or
- c) A switching device of equivalent reliability.

23.4 Operation of an overcurrent-protective device shall not interfere with the functioning of an auxiliary circuit unless it also opens the heating-element circuit or causes the circuit to be opened.

24 Capacitors

24.1 A capacitor employing a liquid dielectric medium more combustible than askarel shall not expel the dielectric medium when tested in accordance with the applicable performance requirements in this standard, including faulted-overcurrent conditions based on the branch circuit on which it is used.

25 Switches

25.1 A switch shall have a current and voltage rating not less than that of the load that it controls when the appliance is operated as described in 45.3.8.

25.2 The current rating of a switch that controls a solenoid, a magnet, a transformer, an electric-discharge-lamp ballast, or another inductive load shall be at least twice the rated full-load current of the component that it controls unless the switch has been found acceptable for the control of an inductive load at least equal to the rated full-load current of the component.

25.3 A switch provided as part of an appliance intended to be connected to a power-supply circuit involving a potential to ground or more than 150 volts shall be acceptable for the maximum potential to ground of the circuit. See 60.3.

25.4 A switch that controls a medium-base lampholder of other than an oven, pilot, or indicating lamp shall be acceptable for use with a tungsten-filament lamp. A switch that controls an intermediate- or candelabra-base lampholder of other than an oven, a pilot, or an indicating lamp shall be acceptable for use with a lamp rated not less than 25 watts.

25.5 A switch that does not have a tungsten-filament lamp rating and that is used for controlling a tungsten-filament load shall have a current rating more than six (for alternating-current) or ten (for direct-current) times the rating of the load.

25.6 A switch shall be judged with respect to the temperature limitations of the materials employed.

25.7 A switch shall be located or protected so that it will not be subjected to mechanical damage in use.

25.8 All switches shall be of the indicating type. The indicating means may be incorporated on the switch or knob, on an attached plate, or on the panel on which the switch is mounted. A pilot light that complies with the requirements of 25.9 may also be used as a means of indication.

25.9 A filament or signal lamp used as a means of indication shall:

- a) Have an estimated life at the operating voltage of not less than 20,000 hours; and
- b) Be connected in a circuit in which the increased voltage incident to switching or any operational characteristic of the appliance does not exceed 120 percent of the voltage recommended to provide the required estimated life.

25.10 A switch in a portable deep-fat fryer or a fixed or stationary appliance that controls a heating element and has a marked off position shall open all ungrounded conductors of the heating-element circuit or cause the conductors to be opened.

25.10 revised November 4, 1993

25.11 A switch controlling an exposed open-wire element of a toaster shall be of such a type and so connected that it will disconnect the element or elements from all conductors of the power-supply circuit. This applies to a switch in the off position or any other position of the switch in which the element is not heated.

25.12 A switch controlling an exposed open-wire element in the rotating head of a cotton candy maker shall be of such type and so connected that it will disconnect the element from all conductors of the power-supply circuit when power to the drive mechanism for the rotating head is interrupted.

25.13 A switch controlling one or more plug-in or movable surface heating elements of a permanently connected appliance shall open all ungrounded conductors of the heating element or elements that it controls or cause the conductors to be opened.

25.14 A switch shall be provided for the control of each section, such as an oven or a warming unit, of a permanently connected appliance.

25.15 A switch or other means of control intended to permit the use of a limited number of elements at one time shall be so located or of such type that the user cannot readily change the connections to permit the use of more elements than intended.

25.16 A manually operated motor-control switch shall be provided in a cord-connected appliance that employs a motor rated more than 1/3 horsepower (250 W output).

26 Lampholders

26.1 A lampholder intended to be connected to a power-supply circuit without a grounded conductor shall be located so that a tool is required to change the lamp. The marking specified in 62.13 shall be provided.

26.2 A screw shell lampholder for an infrared lamp shall be:

- a) Of the unswitched medium-base type, and
- b) For use with a 300-watt or smaller lamp.

Exception: A lamp-and-lampholder combination need not comply with the requirement if no unacceptable temperature is attained on any of the components in the normal temperature test, and if the switching mechanism of a switched lampholder has been investigated and found to be acceptable.

26.3 A lampholder screw shell of a cord-connected appliance shall not operate at a potential of more than 150 volts to ground. See 60.3.

Exception: A lampholder for a pilot light or indicating lamp.

26.4 A female screw shell used as a holder for a heating element shall be of copper or a copper base alloy and shall be plated with nickel or an equivalent oxidation-resistant metal.

26.5 Current-carrying parts of a lampholder in an oven of an appliance shall be of a material such as copper or a copper-base alloy plated with nickel, stainless steel, or equivalent oxidation-resistant metal. Aluminum shall not be employed.

26.6 A lampholder that is likely to be exposed to moist vapors during the operation of the appliance shall not employ a paper liner.

27 Secondary Circuits

27.1 General

27.1.1 Each secondary circuit is to be judged under the requirements for line-voltage circuits.

Exception: A secondary circuit need not be investigated if:

- a) *It is not a safety circuit, and*
- b) *It complies with the requirements for a limited-energy-secondary circuit as described in 27.2.*

27.1.1 revised November 4, 1993

27.1.2 A wiring compartment or the equivalent for field-wiring terminals for a secondary circuit shall be separate from wiring compartments for other terminals.

27.1.3 Secondary circuits may be connected to the frame of the appliance. Except as noted in 27.1.4 and 27.2.6, the connection shall be made at only one point in the appliance or system.

27.1.4 A grounding bus of adequate ampacity that is used as the return for a secondary circuit other than as covered by 27.2.6 may be connected to the frame at more than one point.

27.1.5 If any secondary circuit having an open-circuit potential of more than 42.4 volts peak is connected to the frame of an appliance, all exposed dead metal parts that might become energized, and all dead metal parts within the enclosure that can be touched by a person during operator servicing and that might become energized, shall be reliably connected together.

27.2 Limited-energy-secondary circuits

27.2.1 A limited-energy-secondary circuit shall be supplied from:

- a) Class 2 transformer, or
- b) An isolating transformer having an open-circuit sinusoidal potential of 30 volts, rms (42.4 volts peak) or less, and that includes at least one of the following means, that limits the power available to the levels specified for a Class 2 transformer.
 - 1) A reliable fixed impedance;
 - 2) A noninterchangeable fuse – the largest fuse that fits in the fuseholder provided;
 - 3) A nonadjustable manually reset circuit protector; or
 - 4) A reliable regulating network.

27.2.2 The impedance, the fuse, the protector, or the regulating network and the wiring between them and the isolating transformer described in 27.2.1 shall be judged as if they were part of a line-voltage circuit.

27.2.3 A fuse or a circuit protector used to limit the power as specified in 27.2.1 shall be rated or set at not more than 3.2 amperes for a circuit operating between 15 and 30 volts and at not more than 5.0 amperes for a 0 – 15-volt circuit.

27.2.4 An impedance or a regulating network that is used to limit the current shall be of such value or design as to limit the current under short-circuit conditions to not more than 8.0 amperes measured after 2 minutes.

27.2.5 The performance of a regulating network used to limit the power in accordance with 27.2.1 shall not be adversely affected by either short circuit or open circuit between any two terminals of any single rectifier, capacitor, transistor, or similar component in the network.

27.2.6 The frame may be used as the return for a limited-energy-secondary circuit.

27.2.7 The wiring in a limited-energy-secondary circuit shall be acceptably routed away from the wiring of other circuits or shall be provided with insulation that is for use at the highest of the voltages in the other circuits.

27.2.8 The wiring in a limited-energy-secondary circuit shall be acceptably routed away from the uninsulated live components of other circuits.

27.2.9 Wires and cables that are part of a limited-energy-secondary circuit shall be provided with strain relief in accordance with 10.6.1 and 10.6.2 and the Strain Relief Test, Section 47, if stress on the wire or cable could cause the internal wiring of the circuits to contact uninsulated live parts of other circuits.

28 Spacings

28.1 In primary circuits, other than at field-wiring terminals and except as noted in 28.2 – 28.6, the spacings between uninsulated live parts of opposite polarity, and between an uninsulated live part and a dead metal part shall not be less than specified in Tables 28.1 and 28.2.

Table 28.1
Minimum acceptable spacings other than at field wiring terminals and in motors

Potential involved, volts	Minimum spacings, inch (mm) ^a	
	Over surface	Through air
0 – 50	1/16 (1.6)	3/64 (1.2)
51 – 125	3/32 (2.4)	1/16 (1.6)
126 – 250	1/8 (3.2) ^{b,c}	3/32 (2.4) ^{b,c}
	5/32 (4.0) ^{b,d}	1/8 (3.2) ^{b,d}
251 – 480	1/4 (6.4) ^b	5/32 (4.0) ^b
481 – 600	3/8 (9.5) ^{b,e}	1/4 (6.4) ^b

^a At heating elements, these spacings shall not be less than 1/16 inch up to 300 volts.
^b Enameled wire is to be considered as if it were an uninsulated live part. However, 3/32 inch and greater spacings over surface and through air are acceptable between dead metal parts and enameled wire that is rigidly supported and held in place on a coil.
^c Between uninsulated live parts and grounded metal.
^d Between uninsulated live parts of opposite polarity.
^e At heating elements this spacing shall not be less than 1/4 inch.

Table 28.2
Minimum acceptable spacings at field-wiring terminals

Parts involved	Minimum spacings, inch (mm) ^a			
	0 – 250 Volts		251 – 600 Volts	
	Through air	Over surface	Through air	Over surface
Between live parts of opposite polarity; and between a live part and a dead metal part other than the enclosure	1/4 (6.4)	3/8 (9.5)	3/8 (9.5)	1/2 (12.7) ^b
Between a live part and the enclosure	1/2 (12.7)	1/2 (12.7)	1/2 (12.7)	1/2 (12.7)

^a These spacings do not apply to connecting straps or buses extending away from wiring terminals; such spacings are judged under the requirements in Table 28.1.
^b A spacing of not less than 3/8 inch, over surface, is acceptable at wiring terminals in a wiring compartment or terminal box that is integral with a motor.

Table 28.3
Minimum acceptable spacings within motors

Potential involved, volts	Parts involved	Minimum spacings, inch (mm)			
		Motor diameter 7 inches (178 mm) or less ^a		Motor diameter more than 7 inches (178 mm) ^a	
		Over surface	Through air	Over surface	Through air
0 –125	Between commutator bars or collector rings of a motor and the motor shaft and laminations	1/16 (1.6)	1/16 (1.6)	3/16 (4.8) ^b	1/8 (6.4) ^b
126 – 250	Elsewhere in the motor	3/32 (2.4) ^c	3/32 (2.4) ^c	1/4 (6.4) ^{b,d}	1/8 (3.2) ^{b,d}
	Between commutator bars or collector rings of a motor and the motor shaft and laminations	1/16 (1.6)	1/16 (1.6)	3/16 (4.8) ^b	3/16 (4.8) ^b
251 – 600	Elsewhere in the motor	3/32 (2.4)	3/32 (2.4)	1/4 (6.4) ^{b,d}	1/4 (6.4) ^{b,d}
	Between commutator bars or collector rings and live parts of the brush rigging of a motor and the motor shaft and laminations	1/4 (6.4)	1/4 (6.4)	3/8 (9.5)	1/4 (6.4)
	Elsewhere in the motor	1/4 (6.4) ^d	1/4 (6.4) ^d	3/8 (9.5) ^d	3/8 (9.5) ^d

^a See 19.1.4.
^b Spacings of not less than 3/32 inch are acceptable throughout a universal motor.
^c For a motor rated 1/3 horsepower (250 W output) or less, these spacings may not be less than 1/16 inch.
^d Enameled wire is considered to be an uninsulated in part. However, a spacing of not less than 3/32 inch over surface and through air, is acceptable between enameled wire rigidly supported and held in place on a coil and a dead metal part.

28.2 The acceptability of the inherent spacings of a component, such as a switch, is to be based on the requirements that cover the component.

28.3 Within a thermostat, the spacing – except at contacts – between uninsulated live parts on opposite sides of the contacts shall not be less than 1/32 inch (0.8 mm) through air and 3/64 inch (1.2 mm) over the surface of insulating material. The construction shall be such that the spacings will be maintained permanently.

28.4 The spacing from the wire of an open wire heating element to the cover shall not be less than 1/8 inch (3.2 mm).

28.5 At closed-in points only, such as the screw-and-washer construction of an insulated terminal mounted in metal, in an appliance rated 250 volts or less, a spacing of 3/64 inch (1.2 mm) is acceptable.

28.6 The spacing through air between an uninsulated live part and an enclosure panel when tested as described in the Enclosure Strength Test, Section 43, shall not be less than:

- a) One-half inch (12.7 mm) for a flat panel having an unsupported area greater than 1 square foot (929 cm²), or

- b) The minimum through-air spacing that would otherwise be acceptable between an uninsulated live part and dead metal for smaller areas.

Exception: This requirement does not apply to the inherent spacing between an uninsulated live part of a component complying with 3.1 and an enclosure panel on which the component is mounted.

28.7 If an uninsulated live part is not rigidly fixed in position by a means other than friction between surfaces, or if a movable dead metal part is in proximity to an uninsulated live part, the construction shall be such that the spacing will not be less than the minimum acceptable spacing with the movable part in any position.

28.8 Requirements for primary circuit spacings apply to all secondary circuits that are safety circuits and to all secondary circuits supplied by a transformer winding of 200 volt-amperes or a higher capacity – maximum available power – at a potential higher than 100 volts. Except as noted in 27.1.1, the spacings in all other secondary circuits are judged on the basis of the dielectric voltage-withstand test described in 42.2.1.

28.9 At terminal screws and studs to which connection can be made in the field by means of wire connectors, eyelets, or the like as described in 10.3.1, spacings shall not be less than specified in Tables 28.1 and 28.3 with such connectors, eyelets, and the like in position that minimum spacings – opposite polarity and to dead metal – exist.

28.10 Enameled wire is considered to be an uninsulated live part when spacings are being judged.

28.11 With reference to Tables 28.1 and 28.2, the measurement of spacings over surface shall include the walls of a groove wider than 5/64 inch (2.0 mm).

28.12 An insulating lining or barrier of vulcanized fiber or similar material employed where spacings would otherwise be unacceptable shall not be less than 1/32 inch (0.8 mm) thick, and shall be so located or of such material that it will not be adversely affected by arcing.

Exception No. 1: Vulcanized fiber not less than 1/64 inch (0.4 mm) thick may be used in conjunction with an air spacing of not less than 50 percent of the spacing required for air alone.

Exception No. 2: An insulating liner or barrier may be less than 1/64 inch thick if the material is judged acceptable for the application in accordance with Electrical Insulation, Section 17.

PROTECTION AGAINST INJURY TO PERSONS

29 Scope

29.1 The performance and construction requirements in Sections 29 – 38 are applicable to appliances covered by this standard that may involve a risk of injury to persons in intended operation.

29.2 There are risks of injury to persons inherent in some appliances that, if completely eliminated, would defeat the utility of the appliance. The requirements in this section are intended to minimize such risks, while retaining the intended function of such appliance.

30 General

30.1 If operation, maintenance, or reasonably foreseeable misuse of an appliance by the user involves a risk of injury to persons, protection shall be provided for the reduction of such risk to an acceptable degree.

30.2 Among the factors to be considered in judging the acceptability of an exposed moving part are:

- a) Degree of exposure necessary to perform its intended function,
- b) Sharpness of the moving part,
- c) Likelihood of unintentional contact therewith,
- d) Speed of the moving part, and
- e) Likelihood that a part of the body would be endangered or that clothing would be entangled by the moving part.

These factors are to be considered with respect to both intended operation of the appliance and its reasonably foreseeable misuse.

30.3 The adequacy of a guard, a safety release, an interlock, and the like and whether or not such a device is required, are to be determined from a study of the complete appliance, its operating characteristics, and the likelihood of a risk of injury to persons resulting from a cause other than gross negligence. The investigation is to include consideration of the results of breakdown or malfunction of any one component; but not more than one component at a time, unless one event contributes to another. If the study shows that malfunction of a particular component can result in a risk of injury to persons, that component is to be investigated for acceptability.

30.4 Specific tests, constructions, markings, guards, and the like are detailed for some appliances. Such detailed requirements apply to common constructions; specific features and appliances not covered herein are to be given appropriate consideration.

31 Enclosures and Guards

31.1 Moving parts capable of causing injury to persons shall be enclosed.

Exception: An appliance that is provided with an on-off control that is readily accessible from the operating position, if complete guarding of a moving part that obviously involves a risk of injury to persons would defeat the utility of the appliance.

31.2 An opening in a guard or enclosure around a moving part that involves a risk of injury to persons shall not permit the probe illustrated in Figure 7.1 to contact the part.

Exception: In a convection oven, an air-circulating fan that is provided with a guard that will not permit the entrance of a 3-inch (76-mm) diameter probe.

31.3 An enclosure, an opening, a frame, a guard, a knob, a handle, or the like shall not be sufficiently sharp to cause a risk of injury to persons in normal maintenance or use.

Exception: A sharp edge that must be exposed to enable the appliance to perform its intended function.

31.4 A lid or a door, such as a motor-operated cover on a pressure cooker, that can entrap a person, shall be guarded or be actuated by a momentary contact switch that, when released prior to full closure of the lid or cover, reverses the closing operation.

32 Materials

32.1 If the breakage or damage of a part such as an enclosure, a frame, a guard, or the like might result in a risk of injury to persons, the material shall have such properties as to meet the demand of expected loading conditions.

32.2 The requirements in 32.1 apply to those portions of a part adjacent to a moving part or an exposed live part considered to present a risk of injury to persons.

33 Impact Test

33.1 A part as mentioned in 32.1 shall withstand the impact described in 33.2 and 33.3 to the extent that:

- a) A moving part involving a risk of injury to persons or an exposed live part cannot be contacted by the probe illustrated in Figure 7.1 and
- b) The appliance complies with the dielectric voltage-withstand requirements in the Dielectric Voltage-Withstand Test, Section 42.

Exception No. 1: A part known to be acceptable for the application.

Exception No. 2: A component such as a lens, a control knob, and the like.

33.2 A smooth steel sphere, 2 inches (51 mm) in diameter and weighing approximately 1.18 pounds (535 g), is to be allowed to fall vertically from rest through a distance of 51 inches (1.3 m) to strike the part being tested. For a part not able to be struck from above by the freely falling sphere, the sphere is to be suspended by a cord and allowed to fall as a pendulum through a vertical distance of 51 inches.

33.3 If nonmetallic material is used for a part as mentioned in 32.1, the impact test is to be performed on a sample in the as-received condition. The test is then to be repeated on another sample that has cooled to room temperature after exposure for 7 hours in an air oven at a uniform temperature not less than 10°C (18°F) higher than the maximum operating temperature of the material measured under normal operating conditions, but not less than 70°C (158°F).

Exception: Glass or ceramic, or other material that is known to be acceptable with respect to thermal aging.

33.4 With reference to the requirement in 32.1, glass shall be not less than 0.115 inch (2.92 mm) thick if no dimension of the glass is greater than 12 inches (305 mm). Exposed glass having a dimension of 12 inches or more and an area greater than 144 square inches (929 cm²) shall comply with one of the following:

- a) The glass shall be a nonshattering or tempered type that, when broken, complies with the performance specifications in the Performance Specifications and Methods of Test for Safety Glazing Material Used in Buildings, ANSI Z97.1-1984; and
- b) The glass shall withstand an impact from a 2 inch (51 mm) diameter smooth, steel sphere weighing 1.18 pounds (535 g) falling through a distance of 25-1/2 inches (646 mm) without cracking or breaking to the extent that a piece is released or drops from its normal position.

34 Switches, Controls, And Interlocks

34.1 Switches and controls

34.1.1 If unintentional operation of a switch can result in a risk of injury to persons, the actuator of the switch shall be located or guarded so that such operation is unlikely.

34.1.2 With reference to the requirement in 34.1.1, a switch that is located or guarded so that it cannot be turned on by being struck with the palm of the hand is acceptable.

34.1.3 The actuator of a switch may be guarded by recessing, ribs, barriers, or the like.

34.1.4 A deep-fat fryer shall be provided with a switching device or a temperature-regulating control having a marked off position that will de-energize, or cause to be de-energized, each heating element.

34.1.5 All operating controls of a deep-fat fryer, or the actuating mechanisms for such controls, shall be mounted on the appliance in front of the fat kettle and in a readily accessible location.

Exception No. 1: A pressure fryer with a manually closable cover.

Exception No. 2: A temperature control need not be mounted in front of the fat kettle if mounting in such a location would result in flexing of its capillary during normal operation or cleaning.

34.1.6 An automatically reset protective device shall not be employed if automatic resetting might result in injury to a person.

34.1.6 revised November 4, 1993

34.1.7 The requirement in 34.1.6 necessitates the use of an interlock in an appliance if moving parts can cause injury to a person upon the automatic restarting of a motor.

34.2 Interlocks

34.2.1 Moving parts involving a risk of injury to persons protected by a service or loading door interlocked so that such parts are de-energized when the door is opened are acceptably guarded if one of the following conditions is met:

- a) The moving parts stop within 5 seconds after the door is opened, or
- b) The interlock prevents the door from being opened until the moving parts stop.

34.2.2 An interlock actuated by movement of a guard shall permit operation of the parts being guarded only when the guard is in place. With the guard removed, the interlock shall comply with the requirement in 34.2.3.

34.2.3 The actuator of an interlock switch shall be located so that unintentional operation is unlikely. See 34.1.3.

34.2.4 Operation of an interlock in normal use shall not inconvenience the operator so as to encourage deliberate defeat of an interlock.

34.2.5 An interlock shall not be likely to be defeated by food or cooking materials that could accumulate in normal use.

34.2.6 An interlock shall function as intended after 100,000 cycles of operation controlling a load not less than that controlled in the appliance.

35 Parts Subject To Pressure

35.1 General

35.1.1 A part supported or actuated hydraulically shall not present a risk of injury to persons due to pressure loss.

35.1.2 A pressure vessel shall be designed so that:

- a) A lid or door will be prevented from opening until steam pressure is released, and
- b) Steam released under pressure is directed away from the operator.

35.1.3 A means for draining oil or other cooking substances from an appliance that operates under pressure other than normal atmospheric pressure shall be designed so that drainage is not directed toward the operator.

35.1.4 A pressure vessel having an inside diameter of more than 6 inches (152 mm) and subject to a pressure of more than 15 psig (102 kPa) shall be certified by the National Board of Boiler and Pressure-Vessel Inspectors and marked in accordance with the appropriate boiler and pressure vessel code symbol of the American Society of Mechanical Engineers (ASME) for a working pressure not less than the pressure determined in accordance with 35.2.1.

Exception No. 1: A pressure vessel not covered by the inspection procedure of the ASME code, because of its application, shall be designed and constructed so that it will comply with the requirements in 35.2.1.

Exception No. 2: The requirements do not apply to a premixed-beverage container that is replaced when renewing the beverage supply.

35.1.4 revised November 4, 1993

35.2 Pressure tests

35.2.1 A part or an assembly that is subject to air or vapor pressure, including the vapor pressure in a vessel containing only a superheated fluid, during normal or abnormal operation shall withstand without malfunction a pressure equal to the highest of the following that is applicable:

- a) Five times the pressure corresponding to the maximum setting of a pressure-reducing valve provided as part of the assembly, but not more than five times the marked maximum supply pressure from an external source and not more than five times the pressure setting of a pressure-relief device provided as a part of the assembly.
- b) Five times the marked maximum supply pressure from an external source, but not more than five times the pressure setting of a pressure-relief device provided as a part of the assembly.
- c) Five times the pressure setting of a required pressure-relief device.
- d) Five times the maximum pressure that can be developed by an air compressor that is part of the assembly, unless the pressure is limited by a pressure-relief device provided as part of the assembly.

e) Five times the working pressure marked on the part.

Exception No. 1: A section of a pressure system constructed of tubing is considered to comply with the requirements if the maximum pressure obtained during normal or abnormal operation is not greater than the values specified in Table 35.1 for a given diameter and thickness. The tubing is to be continuous or lengths of tubing are to be connected by hard-soldered, brazed, or welded joints.

Exception No. 2: A pressure vessel bearing the ASME code inspection symbol if that vessel is marked with a value of working pressure not less than that to which it is subjected during normal or abnormal operation.

Table 35.1
Maximum pressure for tubing

Outside diameter,		Minimum wall thickness,		Maximum pressure to which tubing is subjected, psig (MPa)					
inch	(mm)	inch	(mm)	Seamless copper		Butt-welded steel		Seamless steel	
3/8	(9.5)	0.016	(0.41)	500	(3.45)	600	(4.14)	1000	(6.90)
or smaller									
1/2	(12.7)	0.016	(0.41)	400	(2.76)	480	(3.31)	800	(5.52)
5/8	(15.9)	0.016	(0.41)	320	(2.21)	384	(2.65)	640	(4.42)
5/8	(15.9)	0.021	(0.53)	420	(2.90)	504	(3.48)	840	(5.80)
3/4	(19.0)	0.021	(0.53)	360	(2.48)	432	(2.98)	720	(4.97)
3/4	(19.0)	0.025	(0.64)	420	(2.90)	504	(3.48)	840	(5.80)
1	(25.4)	0.021	(0.53)	260	(1.79)	312	(2.15)	520	(3.59)
1	(25.4)	0.025	(0.64)	320	(2.21)	384	(2.65)	640	(4.42)

35.2.2 If a test is necessary to determine whether a part complies with requirements in 35.2.1, two samples of the part are to be subjected to a hydrostatic pressure test. Each sample is to be filled with water so as to exclude air, and is to be connected to a hydraulic pump. The pressure is to be raised gradually to the specified test value and is to be held at that value for 1 minute. The results are not acceptable if either sample ruptures or leaks.

Exception: Leakage at a gasket is acceptable if it does not occur at a pressure lower than 40 percent of the required test value.

35.3 Pressure relief devices

35.3.1 A part in which pressure might be generated by an external fire shall be provided with a means of safely relieving pressure such as a pressure-relief device – see 35.3.8 – a fusible plug, a soldered joint, nonmetallic tubing, or other equivalent pressure-relief means.

35.3.2 There shall be no shut-off valve between the pressure-relief means and the parts that it is intended to protect.

35.3.3 A vessel having an inside diameter of more than 3 inches (76 mm) and subject to air or steam pressure generated or stored within the appliance shall be protected by a pressure-relief device.

35.3.4 A gasket shall not be used as the pressure-relief device required by 35.3.3.

35.3.5 The start-to-discharge pressure setting of the pressure-relief device shall not be higher than the working pressure marked on the vessel. The device shall have a discharge rate that relieves the pressure.

35.3.6 A pressure-relief device shall:

- a) Be connected as close as possible to the pressure vessel or parts of the system that it is intended to protect;
- b) Be installed so that it is readily accessible for inspection and repair and cannot be readily rendered inoperative; and
- c) Have its discharge opening located and directed so that:
 - 1) The risk of scalding is reduced to an acceptable degree, and
 - 2) Operation of the device will not deposit moisture on bare live parts or on insulation or components detrimentally affected by moisture.

35.3.7 A pressure-relief device having an adjustable setting is to be judged on the basis of its maximum setting unless the adjusting means is acceptably sealed at a lower setting.

35.3.8 A pressure-relief device is considered to be a pressure-actuated valve or rupture member designed to relieve excessive pressures automatically.

35.3.9 If a pressure-relief device is required, the control responsible for limiting the pressure in the vessel shall perform under rated load for 100,000 cycles of operation and shall prevent the pressure from exceeding 90 percent of the relief-device setting under any condition of intended operation.

36 Stability

36.1 A freestanding appliance shall not overturn when tipped through an angle of 10 degrees from the horizontal as described in 36.2.

36.2 The appliance is not to be energized during the stability test. The test is to be conducted under conditions most likely to cause the appliance to overturn. The following conditions are to be such as to result in the least stability.

- a) The position of all doors, drawers, casters, and other movable or adjustable parts, including that of a supply cord, if any, resting on the surface supporting the appliance;
- b) Connection of, or omission of, any attachment made available by or recommended by the manufacturer.
- c) Provision of, or omission of, any normal load if the appliance is intended to contain a liquid or other mechanical load; and
- d) Direction in which the appliance is tipped.

Exception No. 1: A cord-connected appliance may be tested with the door closed if, on a horizontal surface and the door in any position, the appliance does not tip when a 35 pound force (156 N) is applied to that part of the door edge that is most likely to cause it to tip.

Exception No. 2: A cord-connected appliance that is on casters and weighs 250 pounds (113 kg) or less may be tested with the door closed if, on a horizontal surface and the door in any position, the appliance does not tip when a 15 pound force (67 N) is applied to that part of the door edge that is most likely to cause it to tip.

Exception No. 3: A cord-connected appliance with drawers may be tested with the drawers closed if, on a horizontal surface, the appliance does not tip when a 35 pound force (156 N) is applied to that part of the outer edge of an open drawer that is most likely to cause it to tip.

36.3 A permanently-connected appliance is to be tested when installed in accordance with the manufacturer's instructions.

36.4 An appliance equipped with wheels, casters, or the like shall have at least two manually operated locks for the wheels, a floor lock, or the equivalent.

36.5 A drawer shall have an acceptable means, such as a mechanical stop, to prevent inadvertent removal of the drawer from its frame, if inadvertent removal could result in a risk of injury to persons.

Exception: A grease drawer having a dimension more than 12 inches (305 mm) from front to back need not have a mechanical stop.

36.6 A deep-fat fryer provided with a heating element that may be raised above the intended operating position, shall incorporate an acceptable means, such as a counterbalance or latch, that will retain the heating element in the raised position until it is lowered manually.

37 Surface Temperatures

37.1 During the temperature test, the temperature of a surface that may be contacted by the user shall not be more than the value specified in Table 37.1. The results of a test that is conducted at a room temperature of other than 25°C (77°F) are to be corrected to 25°C.

Exception: The temperatures of a surface marked in accordance with 38.4 may exceed the values specified in Table 37.1.

Table 37.1
Maximum acceptable surface temperature

Location or type of surface	Composition of surface ^a			
	Metallic		Nonmetallic	
	Degrees		Degrees	
	C	F	C	F
Handle or knob grasped for lifting, carrying, or holding	50	122	60	140
Handle or knob contacted, but not involving lifting, carrying, or holding; other surfaces subject to contact in operation and user maintenance	60	140	85	185
Surface other than a heating function surface, known to be hot due to proximity to the heating function surface	70	158	95	203

^a A material, other than metal, that is plated or clad with metal having a thickness of 0.005 inch (0.13 mm) or less is judged as a nonmetallic part.

38 Warning Markings

38.1 A warning marking shall be permanent and legible, shall contrast with its background, and shall be located on a part that cannot be removed without impairing the operation or appearance of the appliance.

38.2 A warning marking shall be visible from the operator's position or from the position in which a specific risk of injury to persons would be encountered.

38.3 In a warning marking, the words "CAUTION," "WARNING," or "DANGER" shall be in letters not less than 3/32 inch (2.4 mm) high.

38.4 If the temperature of the surface exceeds the limits specified in Table 37.1, the appliance shall be marked with the word "CAUTION" and the following or the equivalent "HOT." See 37.1. This marking shall be located on or adjacent to the surface in question.

Exception: A surface that, because of its location, is known to be hot need not be marked. Examples of such surfaces are a handle of a deep-fat fryer kettle, a handle of a broiler drawer, and the horizontal surface of a cooktop containing surface-cooking units.

38.5 A switch, other than a momentary contact switch, that controls a motor that drives a moving part that can injure a person, shall have a plainly marked off position.

38.6 A control of a deep-fat fryer that de-energizes, or causes to de-energize, the heating elements shall have a marked off position. See 34.1.4.

PERFORMANCE

39 General

39.1 The performance of an appliance shall be investigated by subjecting the requisite number of samples to all the applicable tests described in Sections 40 – 59. Insofar as is practicable, the tests shall be conducted in the order in which they are presented.

39.1 revised November 4, 1993

39.2 An appliance intended for operation on direct current as well as on alternating current is to be tested with a direct-current supply.

39.3 A pressure gauge is to be attached so as to prevent leakage. Special fittings for direct connection to the system or commercial tubing or pipe may be employed for gauge connections. Volume of the pressure-measuring gauge and lines shall be held to a minimum relative to pressure vessel size.

40 Leakage Current Test

40.1 The leakage current of a cord-connected appliance rated for a nominal 120-volts supply when tested in accordance with 40.3 – 40.8 shall be not more than:

- a) 0.5 milliamperes for a portable appliance, and
- b) 0.75 milliamperes for a stationary or fixed appliance employing a standard attachment plug rated 20 amperes or less.

40.2 Leakage current refers to all currents, including capacitively coupled currents, that may be conveyed between exposed conductive surface of an appliance and ground or other exposed conductive surfaces of an appliance.

40.3 All exposed conductive surfaces are to be tested for leakage currents. The leakage currents from these surfaces are to be measured to the grounded supply conductor individually as well as collectively if simultaneously accessible and from one surface to another if simultaneously accessible. Parts are considered to be exposed surfaces unless guarded by an enclosure that provides for protection against electric shock as described in 7.1.1 – 7.1.8. Surfaces are considered to be simultaneously accessible if they can be readily contacted by one or both hands of a person at the same time. These measurements do not apply to terminals operating at voltages that are not considered to present a risk of electric shock. See 7.1.2.

40.4 If a conductive surface other than metal is used for the enclosure or part of the enclosure, the leakage current is to be measured using metal foil having an area of 10 by 20 centimeters in contact with the surface. If the surface is less than 10 by 20 centimeters, the metal foil is to be the same size as the surface. The metal foil is not to remain in place long enough to affect the temperature of the appliance.

40.5 The measurement circuit for leakage current is to be as illustrated in Figure 40.1. The measurement instrument is defined in (a) – (c). The meter that is actually used for a measurement need only indicate the same numerical value for a particular measurement as would the defined instrument. The meter used need not have all the attributes of the defined instrument.

- a) The meter is to have an input impedance of 1500 ohms resistive shunted by a capacitance of 0.15 microfarad.
- b) The meter is to indicate 1.11 times the average of the full-wave rectified composite waveform of voltage across the resistor or current through the resistor.

c) Over a frequency range of 0 – 100 kilohertz, the measurement circuitry is to have a frequency response – ratio of indicated to actual value of current – that is equal to the ratio of impedance of a 1500 ohm resistor shunted by a 0.15 microfarad capacitor to 1500 ohms. At an indication of 0.5 or 0.75 milliampere, the measurement is to have an error of not more than 5 percent at 60 hertz.

40.5 revised November 4, 1993

Figure 40.1
Leakage current measurement circuit

Figure 40.1 revised February 18, 1998

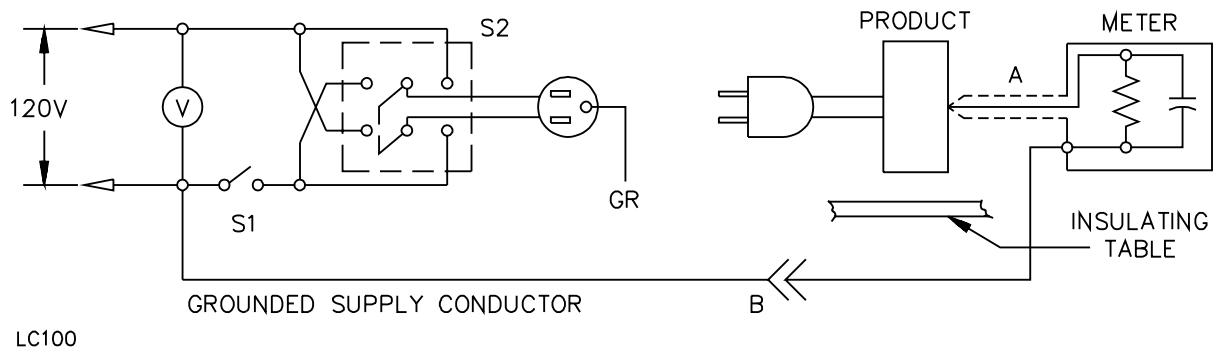

NOTE:

A. Probe with shielded lead.

B. Separated and used as clip when measuring currents from one part of device to another.

40.6 Unless the meter is being used to measure leakage from one part of an appliance to another, the meter is to be connected between an accessible part and the grounded supply conductor.

40.7 A sample of the appliance is to be tested for leakage current starting with the as-received condition with all its switches and thermostats closed, but with its grounding conductor, if any, open at the attachment plug. The as-received condition is without prior energization except as may occur as part of the production-line testing. The supply voltage is to be adjusted to 120 volts. The test sequence, with reference to the measuring circuit, Figure 40.1, is to be as follows:

- a) With switch S1 open, the appliance is to be connected to the measuring circuit. Leakage current is to be measured using both positions of switch S2.
- b) With the appliance controls at the maximum heat setting, switch S1 is to be closed, energizing the appliance, and within 5 seconds the leakage current is to be measured using both positions of switch S2.

No Text on This Page

c) Leakage current is to be monitored until thermal stabilization under the maximum-heat conditions. Both positions of switch S2 are to be used. The equivalent of thermal stabilization is considered to be obtained as in the normal temperature test. If the thermostat does not cycle at the maximum heat setting, it is to be adjusted until it does cycle before the final measurements at thermal stabilization are taken. Measurements are to be made with the thermostat, if any, open and closed. Normally following the 5-second measurements described in (b) the first monitoring reading will be taken 10 minutes after energizing. Upon evidence of stabilizing readings, monitoring periods may be increased.

d) If the appliance employs a single-pole switch or a thermostat having an off position, monitoring of leakage current is to continue until the leakage current stabilizes or decreases after the appliance is turned off.

40.8 Usually, the complete leakage current test program as described in 40.7 is to be conducted without interruption for other tests. With the concurrence of those concerned, the leakage current tests may be interrupted for the purpose of conducting other nondestructive tests.

41 Power Input Test

41.1 The power input to an appliance shall not exceed 105 percent of its marked rating.

41.2 To determine whether an appliance complies with the requirement in 41.1, the power input is to be measured with the appliance at intended operating temperature under full-load conditions and while connected to a power-supply circuit of rated voltage. The rated voltage of an appliance having a marked voltage range, such as 110 – 120 volts, is considered to be the mean of the range.

41.3 In addition to the test required by 41.2, if the marked voltage rating of an appliance falls within a voltage range mentioned in 60.2, the input is to be determined at the maximum voltage of the range. Provisions for connection to the source of supply are to be evaluated by the input current determined at this voltage. See 10.3.2 and 10.3.5.

41.4 The power input to an appliance that employs a nonmetallic heating element, such as carbon, is to be determined when the element is new – that is, when it is first subjected to heat.

42 Dielectric Voltage-Withstand Test

42.1 General

42.1.1 An appliance shall withstand for 1 minute without electrical breakdown the application of a 60-hertz essentially sinusoidal potential between live parts and dead metal parts with the appliance at the operating temperature attained in normal use. The test potential shall be 1000 volts for an appliance rated 250 volts or less, and shall be 1000 volts plus twice rated voltage for an appliance rated more than 250 volts.

42.1.2 To determine whether an appliance complies with the requirements in 42.1.1, it is to be tested by means of a 500 volt-ampere or larger capacity testing transformer, the output voltage of which can be regulated. The applied potential is to be increased from zero to the required value at a substantially uniform rate as rapid as is consistent with its value being correctly indicated by a voltmeter. The potential is to be held at that value for 1 minute.

42.1.3 For the dielectric voltage-withstand test of an appliance in which electrical wiring passes through a hinged member or spring, the cover or other movable member is to be raised and lowered not less than three times while the test potential is being applied in order to determine whether a breakdown may result from damaged insulation on the conductors with the cover in other than the closed position.

42.2 Secondary Circuits

42.2.1 Secondary circuits of an appliance shall withstand for 1 minute the application of a test potential as specified in Table 42.1:

- a) Between primary and secondary circuits,
- b) Between secondary circuits and grounded metal with all chassis-connected components disconnected at the chassis, and
- c) Between secondary circuits supplied from separate transformer windings with common connections disconnected.

The appliance is to be at its maximum intended operating temperature during the test.

Table 42.1
Magnitude of test potential

Maximum voltage in the circuit	Test voltage
90 or less	Ten times maximum voltage in circuit
More than 90 but not more than 333	1000
More than 333 but not more than 1000	Three times maximum voltage in circuit
More than 1000	1750 plus 1.25 times the maximum voltage in the circuit

42.2.2 The test potential mentioned in 42.2.1 may be obtained from any convenient source having a capacity of at least 500 volt-amperes to maintain the potential specified in Table 42.1 except in case of breakdown. The voltage of the source is to be continuously variable. A direct-current source is to be used for a direct-current circuit. A 60-hertz sinusoidal voltage is to be used for testing alternating-current circuits.

42.3 Transformers

42.3.1 While at its maximum intended operating temperature, each power transformer shall operate without breakdown while the potential specified in Table 42.1 is induced for 1 minute in each secondary winding that normally operates at a higher potential than the primary winding.

42.3.2 A sinusoidal source is to be used for a transformer, and the frequency of the source may be in the range of 180 to 1000 hertz if necessary to prevent saturation of the core.

42.3.3 Primary- and secondary-circuit wiring connected to a transformer is to be disconnected for the test required by 42.3.1.

43 Enclosure Strength Test

43.1 The external enclosure shall withstand a force of 20 pounds (89 N) without permanent distortion reducing spacings below the values specified in 28.6 or transient distortion that results in contact with live parts. The force is to be applied by means of a 1/2-inch (12.7-mm) diameter rod with a hemispherical end. Any opening that occurs during application of the force is to be judged under the requirements in 7.1.4 – 7.1.8.

43.2 The external enclosure shall withstand an impact as described in 43.3 without permanent distortion reducing spacings below the values specified in 28.6 or transient distortion that results in contact with live parts. Any openings resulting from the impact are to be judged under the requirements in 7.1.4 – 7.1.8.

43.3 The impact described in 43.2 is to be applied by means of a solid, smooth, steel sphere 2 inches (51 mm) in diameter and weighing approximately 1.18 pounds (535 g). The sphere is to fall freely from rest through a vertical distance of 51 inches (1.3 m).

44 Resistance To Moisture Test

44.1 After being operated as described in 44.2, an appliance having an electrical part that is exposed to moisture produced by the appliance, such as a proofing cabinet, shall comply with the following, as applicable.

- a) A cord-connected appliance rated for a nominal 120-volt supply, shall comply with the requirement in 40.1 in a repeated leakage current test, except that the test is to be discontinued when leakage current stabilizes.
- b) An appliance, other than a cord-connected appliance rated for a nominal 120-volts supply shall have an insulation resistance of not less than 50,000 ohms.
- c) The appliance shall withstand without breakdown for 1 minute the application of the potential specified in 42.1.1.

44.2 The appliance is to be connected to the water line or water is to be added as intended and the appliance is to be operated continuously under standby conditions – heated, but not dispensing water – for 24 hours immediately after which the insulation resistance or leakage current is to be measured and the test potential is to be applied.

44.3 An appliance, such as a hot cup, that is likely to be immersed in water for cleaning shall have a leakage current of not more than 0.5 milliamperes and shall withstand a potential of 1000 volts when tested in accordance with 44.4 and 44.5. There shall be no entrance of water into the appliance that might come into contact with uninsulated live parts as a result of the test.

44.4 Three samples of the appliance are to be filled with cold water and are to be heated as described in 45.3.8. When the water boils, each appliance is to be emptied and is to be completely immersed for 3 – 10 seconds in a detergent solution maintained at a temperature of 40°C (104°F) maximum.

44.5 The entire procedure of heating and immersion is to be repeated until 1000 hours have elapsed, immediately after which each appliance is to be subjected to the leakage current and dielectric voltage-withstand test, the heating element terminals and insulators are to be wiped with a towel to remove surface moisture. Each sample is then to be disassembled and the internal parts are to be visually examined for the presence of water to determine whether the appliance complies with the requirement in 44.3.

45 Normal Temperature Test

45.1 General

45.1.1 When an appliance is tested under the conditions described in 45.3 – 45.4, the temperature at any point shall not adversely affect any materials employed in the appliance, and at any time during the test, temperature rises shall not exceed those specified in Table 45.1.

Exception: A short length of flexible cord exposed to a temperature higher than the temperature rating of the cord, such as at terminals, but not in a strain relief or similar location where dependence is placed on the mechanical properties of the insulation, is acceptable if supplementary heat-resistant insulation of dielectric strength and temperature rating is employed on the individual conductors of the cord that protects the conductor insulation against deterioration.

45.1.1 revised November 4, 1993

Table 45.1
Maximum acceptable temperature rises

Table 45.1 revised November 4, 1993

Materials and components	Degrees	
	°C	°F
1. Any point within a terminal box or wiring compartment of a permanently connected appliance in which field-installed conductors are to be connected, including such conductors themselves, unless the appliance is marked in accordance with 62.3.	35	63
2. Any point on a surface adjacent to an appliance, including the surface on which the appliance is mounted ^{f,h}	65	117
3. Fuses ^g	65	117
4. Vulcanized fiber used as electrical insulation or as a cord bushing.	65	117
5. Wood or other combustible material.	65	117
6. Cotton or rayon braid on Types AFPD and AFPO flexible cord.	65	117
7. Class 105 insulation systems on windings of a relay or a solenoid:		
Thermocouple method	65 ^a	117 ^a
Resistance method	85	153
8. Class A insulation systems on coil windings of an a-c motor having a frame diameter of more than 7 inches (178 mm) ^c and of a d-c and a universal motor ^{a, d} :		
A. In an open motor:		
Thermocouple method	65	117 ^a
Resistance method	75	135
B. In a totally enclosed motor:		
Thermocouple method	70	126
Resistance method	80	144
9. Class A insulation systems on coil windings of an a-c motor – not including a universal motor – having a frame diameter of 7 inches (178 mm) ^c or less – thermocouple or resistance method:		
A. In an open motor	75 ^a	135 ^b
B. In a totally enclosed motor	80	144
10. Class 105 insulation systems on a vibrator coil – thermocouple or resistance method ^a .	75	135
11. Class B insulation systems, other than as indicated in items 12, 13, and 14;		
Thermocouple method	85	153
Resistance method	105	189
12. Class B insulation systems on coil windings of an a-c motor having a frame diameter of more than 7 inches (178 mm) ^c and of a d-c and a universal motor ^b :		
A. In an open motor:		
Thermocouple method	85 ^a	153 ^b
Resistance method	95	171
B. In a totally enclosed motor:		
Thermocouple method	90	162
Resistance method	100	180
13. Class B insulation systems on coil windings of an a-c motor – not including a universal motor – having a frame diameter of 7 inches (178 mm) ^c or less – thermocouple or resistance method ^a :		
A. In an open motor	95 ^a	171 ^b
B. In a totally enclosed motor	100	180

Table 45.1 Continued on Next Page

Table 45.1 Continued

Materials and components		Degrees	
		°C	°F
14.	Class 130 insulation systems on a vibrator coil – thermocouple or resistance method ^a .	95	171
15.	Phenolic composition employed as electrical insulation or relied upon to prevent a hazardous condition ^c .	125	225
16.	A copper conductor (bare or insulated) without a nickel coating or similar protection.	125	225
17.	Termination of a copper conductor and a pressure terminal connector without a nickel coating or other similar protection.	125	225
18.	Insulated wire or cord	25°C (77°F) less than its temperature rating	
19.	Sealing compound	40°C (104°F) less than its melting point	
20.	On the surface of a capacitor casing:		
	Electrolytic	40 ^d	75 ^d
	Other types	65 ^e	117 ^e
21.	Diodes, silicon	75	135
22.	Class 105 insulation systems on transformers:		
	Thermocouple method	65	117
	Resistance method	75	135
^a At a point on the surface of a coil where the temperature is affected by an external source of heat, the temperature rise measured by means of a thermocouple may be higher than the maximum specified by the following amount, if the temperature rise of the coil measured by the resistance method is not higher than the maximum specified.			
Items		Additional Temperature Rise	
7 and 8(A)		15°C (27°F)	
9(A) and 10		5°C (9°F)	
12(A)		20°C (36°F)	
13(A) and 14		10°C (18°F)	
^b See 19.1.4.			
^c The limitation on phenolic does not apply to a compound that has been investigated and found to have acceptable heat-resistant properties.			
^d The temperature rise on insulating material integral with the enclosure of an electrolytic capacitor that is integral with or attached to a motor shall not be higher than 65°C (117°F).			
^e A capacitor that operates at a temperature rise of more than 65°C (117°F) may be judged on the basis of its marked temperature limit.			
^f The surface on which a floor-mounted, permanently connected appliance is mounted may have a maximum temperature of 125°C (225°F) if the appliance is marked as specified in 62.18, and if the manufacturer's base specified in that paragraph is acceptable for the purpose and available with the appliance.			
^g A fuse that has been investigated and found acceptable for use at a higher temperature may be used at that temperature.			
^h The supporting surface of a floor-mounted, permanently connected, fixed oven employing roll-in racks and/or that uses the floor to complete the oven cavity may have a maximum temperature rise greater than 65°C if the appliance is marked as specified in 62.19.			

45.1.2 All values in the table are based on an assumed ambient temperature of 25°C (77°F), but a test may be conducted at any ambient temperature within the range of 10 – 40°C (50 – 104°F). However, if the operation of an automatic thermal control during the test limits the temperatures under observation, no temperature higher than 25°C (77°F) plus the specified maximum rise is acceptable.

45.1.3 When performing the test described in 45.3.10, the limiting control of a deep-fat fryer shall de-energize the heating elements before the temperature of the oil exceeds 246°C (475°F), and temperature overshoot shall not result in ignition of the oil.

45.1.3 revised November 4, 1993

45.1.4 If more than a thin film of oil or grease can be used in an appliance, such as a tilting frying pan or a popcorn machine, the maximum temperature in the cooking compartment after initial overshoot shall not exceed 315°C (599°F).

45.2 Test Equipment

45.2.1 Supply conductors used for the normal temperature test of a permanently connected appliance shall have an ampacity of 125 percent of the current rating of the appliance; and shall be acceptable for a temperature in accordance with the temperature marking, if any, on the appliance. See 10.3.4, 62.3, and 62.4.

45.2.2 Temperatures are to be measured by thermocouples except as indicated in 45.2.7. The thermocouples are to consist of wires not larger than No. 24 AWG (0.21 mm²) and not smaller than No. 30 AWG (0.05 mm²). The thermocouples and related instruments are to be accurate and are to be calibrated in accordance with good laboratory practice. The thermocouple wire is to conform to the requirements as listed in the Initial Calibration Tolerances for Thermocouples table in Temperature Measurement Thermocouples, ANSI/ISA MC96.1-1982.

45.2.2 revised April 10, 2000

45.2.3 Whenever referee temperature measurements are necessary, thermocouples consisting of No. 30 AWG (0.05 mm²) iron and constantan wires and a potentiometer-type indicating instrument are to be used.

45.2.4 A thermocouple junction and adjacent thermocouple lead wire are to be securely held in good thermal contact with the surface of the material the temperature of which is being measured. In most cases, thermal contact will result from securely tapping or cementing the thermocouple in place; but if a metal surface is involved, brazing or soldering the thermocouple to the metal may be necessary.

45.2.5 Usually, the temperature of a coil or winding is to be measured by means of thermocouples applied at points accessible to a mercury bulb thermometer. In considering the accessibility of the various parts of a coil, the enclosure is to be disregarded because it would be cut away where necessary to accommodate a thermometer if one were used. This limitation on thermocouple location is intended to prevent insertion of the thermocouple into cracks, and the like, of the coil assembly.

45.2.6 For the thermocouple-measured temperature of a coil of an alternating-current motor – other than a universal motor – having a frame diameter of 7 inches (178 mm) or less, item 9 in Table 45.1, the thermocouple is to be mounted on the integrally applied insulation of the conductor.

45.2.7 If the coil is inaccessible for mounting thermocouples – for example, an encapsulated coil or if the coil wrap includes thermal insulation such as asbestos, or more than 1/32 inch (0.8 mm) of cotton, paper, rayon, or similar insulation – the change-of-resistance method is to be used.

45.2.8 In using the resistance method, the windings are to be at room temperature at the start of the test. The temperature rise of a winding is to be calculated from the formula:

$$\Delta t = \frac{R}{r} (k + t_1) - (k + t_2)$$

in which:

t is the temperature rise in °C;

R is resistance of the coil at the end of the test in ohms;

r is resistance of the coil at the beginning of the test in ohms;

t₁ is room temperature at the beginning of the test in °C;

t₂ is room temperature at the end of the test in °C; and

k = 234.5 for copper, 225.0 for electrical conductor grade (EC) aluminum. Values of the constant k for other grades must be determined.

45.3 Procedure

45.3.1 In a test to determine whether an appliance complies with the temperature requirements, it is to be mounted or supported as in actual service and tested under conditions approximating those of normal operation, except as otherwise noted. Temperatures are also to be measured on nearby surfaces, on the supporting surface, at points of support, and at other points as may be necessary.

45.3.2 A cord-connected appliance is to be supported on a horizontal, softwood surface covered with two layers of white tissue paper. It is to be placed in a wall angle of 90 degrees formed by the two black-painted, vertical surfaces of nominal 3/8-inch thick plywood having width and height such that they extend not less than 2 feet (610 mm) beyond the physical limits of the appliance. The appliance is to be located as closely to the sides of the wall angle as its construction will permit and it is to be located so that maximum heating of the walls will occur.

45.3.3 A permanently connected appliance that is designed to rest on a horizontal surface, such as a floor, bench, or shelf, in normal service is to be tested as described in 45.3.2.

Exception: An appliance that is marked in accordance with 61.5 may be spaced away from the sides of the walls.

45.3.4 An appliance intended for permanent connection to the source of supply and for use in arrangements that involve horizontally or vertically adjacent installation of equipment is to be tested to represent such installation. The various appliances and arrangements are to be considered and tests are to include combinations judged to produce the highest temperatures within the equipment, on the adjacent alcove walls, and on the supporting surface. Additional tests may be required to cover various possible configurations.

45.3.5 An automatic temperature-regulating or -limiting control or other protective device is to be shunted out of the circuit, unless the control has been shown, in accordance with Table 49.2, to be reliable, rugged, and unlikely to be defeated by the user. The control is considered to be unlikely to be defeated if a tool is required to gain access to the control, or a positive stop is incorporated in the control.

45.3.6 Unless otherwise specified in 45.4.5 – 45.4.27, temperature-regulating controls or temperature-regulating and -limiting controls that are adjustable are to be set for maximum temperatures.

45.3.7 If an operating temperature is specified, the temperature is the mean of the maximum and minimum readings at thermal equilibrium.

45.3.8 To determine whether an appliance complies with the requirements in 45.1.1, it is to be operated continuously until constant temperatures have been reached. The test voltage is to be the higher of the following:

- a) The marked voltage rating, or
- b) The highest voltage of the applicable range of voltages specified in 60.2 if the marked voltage is within one of the voltage ranges included in 60.2.

45.3.9 Unless a particular voltage or other test condition is specified in 45.3.5 – 45.3.27, the test voltage specified in 45.3.8 is to be increased, if necessary, to cause the wattage input to the appliance to be equal to the wattage rating marked on the appliance.

Exception: The voltage applied to the motor of an appliance that employs a motor in addition to a heating element is not to be more than 120 volts for an appliance rated 100 to 120 volts, and not more than 240 volts for an appliance rated 220 to 240 volts.

45.3.10 If the coil wrap exceeds its temperature limitation because of radiation from an external source, the temperature of the coil may be measured by means of a thermocouple on the integral insulation of the coil conductors.

45.3.11 Feet, or any parts thereof, that are made of a material not acceptable for the temperature attained during the test are to be removed for the temperature test. Metal studs or other means used to retain the material are not to be removed.

45.3.12 The material mentioned in 45.3.11 is to be evaluated in terms of the mechanical strength, temperature, and moisture resistant criteria mentioned in 17.4.

45.3.13 A thermal- or overcurrent-protective device for a motor shall not open the circuit during normal use of the appliance.

45.3.14 An appliance that may be either open or closed in actual service, such as a sandwich toaster or grill, is to be tested both open and closed to determine which condition produces the higher operating temperatures.

45.4 Normal test conditions

45.4.1 In determining whether an appliance complies with the requirements in 45.1.1, actual service conditions or an approximation thereof are to be employed as described in 45.4.5 – 45.4.27. For automatic thermostatically-controlled appliances other than those for which test conditions are specified, any condition of actual operation is considered to be normal. In each case, operation is to be continued until temperatures stabilize.

45.4.2 With reference to those tests that, in accordance with 45.4.5 – 45.4.27, are to be continued until constant temperatures are attained, thermal equilibrium is considered to exist when three successive readings, taken at intervals of 10 percent of the previously elapsed duration of the test indicate no change. No interval is to be less than 5 minutes.

45.4.3 If the design of an appliance is such that cooking or heating of a liquid is the determining factor in the temperature obtained – for example, a coffee maker – the intended duty of the device is to be taken into consideration. Normal operating conditions will not be obtained, however, if certain types of appliances are operated continuously and in a dry condition.

45.4.4 Conditions for the performance of normal temperature tests for appliances of the common types are given in 45.4.5 – 45.4.27.

45.4.5 COFFEE MAKERS, AUTOMATIC – If an adjustable thermostat is provided, the thermostat is to be set for the maximum temperature that does not result in dispensing boiling water. The appliance is to be operated as described below until temperatures stabilize:

- a) A percolator is to be filled with the intended amount of cold water and operated until the thermostat automatically switches to the low or off position, at which time the percolator is to be emptied and refilled with the intended amount of water and the cycle repeated.
- b) An automatic coffee maker is to be operated under standby conditions until temperatures are constant, after which water is to be dispensed in the intended manner. Decanters, or similar utensils, that are filled in the process are to be used, and when filled, replaced with empty decanters.

45.4.6 COFFEE MAKERS, NONAUTOMATIC – The appliance is to be filled with the intended amount of water and operated until temperatures become stabilized. Additional water is to be added during the test if the water level becomes lower than the half-full mark.

45.4.7 COFFEE MAKER STOVES – The stove is to be operated continuously warming water in the intended decanters. As the water in a decanter reaches the temperature at which it is forced into the upper section of the coffee maker, it is to be replaced by a fresh decanter of water at a temperature of 10 – 15°C (50 – 59°F).

45.4.8 POPCORN MACHINES – The test is to consist of continuous operation with switches and thermostat set for maximum temperature while popping corn in the intended manner.

45.4.9 DEEP-FAT FRYERS – The fryer is to be operated continuously with the regulating thermostat set at the maximum heat position and with the oil level at the height recommended by the manufacturer. The limiting control is not to function during these tests except:

- a) For initial overshoot when starting from room temperature,
- b) While the element is in a raised position, or
- c) While the kettle is drained for element burn-off. See 49.2.1 and Table 49.1.

45.4.10 Following the test described in 45.4.9, the regulating thermostat is to be short-circuited. Starting at room temperature, the appliance is to be operated continuously until the oil temperature has peaked for a manually reset thermostat or until the temperature peaks for an automatically reset temperature control have become constant. This test is also to be conducted with any one of the fuses or circuit breakers used to comply with the requirements in 21.9 opened. The temperature is to be measured at the approximate center of the oil pool 1 inch (25.4 mm) below the surface. See 45.1.3.

45.4.10 revised November 4, 1993

45.4.11 HOT FOOD RECEPTACLES FOR STEAM TABLES – The largest containers to be used with the appliance are to be provided, and these containers are to be filled with water. The appliance is to be operated continuously with switches or thermostats set for maximum temperature; except that, if a preheat setting for 15 minutes or for a marked preheat period, whichever is greater; it is then to be operated at the mechanically definite next lower setting until temperatures are constant. If a space beneath the containers may contain water, the appliance is to be operated both with and without water.

45.4.12 HOT FOOD STORAGE CABINETS – The cabinet is to be operated continuously with switches or thermostat set for maximum temperature; except that, if a preheat position above a mechanically definite maximum temperature position is provided on the control, the appliance is to be operated at the preheat setting for 15 minutes or for a marked preheat period, whichever is greater; it is then to be operated at the mechanically definite next lower setting until temperatures are constant. If the appliance includes a water container, it is to be operated both with and without water.

45.4.13 LIQUID HEATERS – The heater is to be operated continuously warming water.

45.4.14 DRINK DISPENSERS – The dispenser is to be operated under standby conditions until temperatures become constant, after which the drink is to be dispensed at a rate of three 6-ounce (177 ml) cups per minute until temperatures again become constant or until the product temperature reaches 48.9°C (120.0°F).

45.4.15 OVENS – The oven is to be operated continuously with the thermostat set for the maximum temperature.

45.4.16 OPEN BROILERS – The broiler is to be operated continuously with all controls set for maximum temperature. Permanently marked instructions – see 61.1 – for adding water to a fat receptacle are to be followed.

45.4.17 PRESSURE FRYERS – The fryer is to be operated as described in 45.4.9 and 45.4.10 until temperatures are constant, after which the fryer is to be operated with the cover closed for the shortest and longest cooking cycles recommended in the operating instructions as necessary to cause maximum heating of the components. Two minutes are to be allowed between cycles for unloading and reloading the cooking chamber.

45.4.18 RADIANT-HEAT FOOD WARMERS – The food warmer is to be operated continuously until temperatures are constant. A food warmer using reflector lamps is to be tested with both clear and colored lamps. Food containers detachable without tools are to be removed for the test.

45.4.19 RANGES – The range is to be operated continuously with the heat control or switch set to give a temperature closest to but not less than 275°C (527°F) on each surface unit. For a surface unit in the form of a flat plate, the temperature is to be measured at the center of the plate. For a surface unit in the form of a coiled sheath, the temperature is to be measured at the center of a circular cast iron or steel stove plate covering the unit. The plate used with a 6 inch (152 mm) or smaller unit is to be 7 – 8 inches (178 – 203 mm) in diameter and is to weigh approximately 3 pounds (1.4 kg). The plate used with a unit larger than a 6 inch size is to be 10 – 11 inches (254 – 279 mm) in diameter and is to weigh approximately 7 pounds (3.2 kg). an oven thermostat is to be set for maximum temperature.

45.4.20 SANDWICH TOASTERS, GRILLS, AND GRIDDLES – The toaster, grill, or griddle is to be operated continuously with the heat-control switch adjusted, or with the applied voltage reduced, to give a surface cooking temperature of 275°C (527°F) or with the heat control switch in the maximum temperature position if a lower temperature is attained. This applies also to combination grills and waffle irons in which reversible grids are used.

45.4.21 STEAM COOKERS, EXTERNAL STEAM SUPPLY – The cooker is to be connected to a steam supply of rated pressure and is to be operated continuously until temperatures become constant. If timers, electric valves, or similar components operate intermittently, the appliance is to be operated with the shortest and longest cooking cycles recommended in the operating instructions as necessary to cause maximum heating of components. One minute is to be allowed between cycles for unloading and reloading the cooking chamber.

45.4.21 revised November 4, 1993

45.4.22 STEAM COOKERS, SELF-CONTAINED STEAM GENERATOR – The cooker is to be operated as described in 45.4.21. If a fitting is provided to supply other appliances, steam is to be drawn off at the maximum rate possible such that the highest operator-adjustable steam pressure is maintained.

45.4.23 TABLE STOVES – The stove is to be operated continuously with each heating unit covered with a pan of water. The pans employed in the test are to be of aluminum, with vertical sides and flat bottoms. The diameter of the bottom plane surface of a pan is not to be smaller than the maximum diameter of the active part of the surface unit on which the pan is used, and is not to be more than 1 inch (25.4 mm) larger than the maximum diameter of the active part of the surface unit.

45.4.24 TILTING FRYING PANS – The frying pan is to be operated continuously with all controls set for maximum temperature until temperatures become constant. See 45.1.4.

45.4.25 TOASTERS – The toaster is to be operated continuously toasting slices of bread to a dark brown color. Immediately preceding the toasting, a nonautomatic toaster is to be preheated for 15 minutes.

Exception: This test may be omitted for a nonautomatic toaster if the results of the abnormal or burnout test show that the appliance is acceptable with respect to normal operation.

45.4.26 WAFFLE IRONS – The waffle iron is to be operated continuously at reduced voltage adjusted to give a grid temperature of 210°C (410°F).

45.4.27 WATER HEATERS FOR COOKING APPLIANCES – The water heater is to be operated continuously with water at a temperature 98°C (208°F) or, for an appliance provided with a thermostat at the maximum temperature setting of the thermostat if it is less than the boiling point of the water in the appliance or as dispensed from the appliance.

46 Grounding And Bonding Test

46.1 Grounding

46.1.1 The grounding blade of the attachment plug and the exposed metal parts mentioned in 11.6 shall be conductively connected as determined by test.

46.1.2 Any indicating device, such as an ohmmeter, a low-voltage battery-and-buzzer combination, or the like, may be employed in the test required by 46.1.

46.1.3 With reference to 11.15, the resistance may be determined by any convenient method except that if unacceptable results are obtained, either a direct or alternating current equal to the current rating of the maximum-current-rated branch-circuit overcurrent-protective device that may be employed with the appliance is to be passed from the equipment grounding terminal or the point of attachment of the wiring system to the dead metal part, and the resulting drop in potential is to be measured between these two points. The resistance in ohms is to be determined by dividing the drop in potential in volts by the current in amperes passing between the two points.

46.2 Bonding

46.2.1 A conductor smaller than that specified in 11.13 may be used if the bonding connection does not open when carrying for the interval specified in Table 46.1, twice the current equal to the rating of the branch-circuit overcurrent device.

Table 46.1
Duration of current for bonding-conductor test

Rating of Overcurrent Devices, Amperes	Minimum Duration of current flow, minutes
30 or less	2
31 – 60	4
61 – 100	6

47 Strain Relief Test

47.1 When tested in accordance with 47.2, the strain relief shall withstand for 1 minute, without displacement, a direct pull of 35 pounds (156 N) applied to the cord with the connections within the appliance disconnected. The means of affording strain relief is not acceptable if, at the point of disconnection of the conductors, there is such movement of the cord as to indicate that stress would have resulted on the connection.

47.2 A 35-pound (15.9-kg) weight is to be suspended on the cord and supported by the appliance so that the strain-relief is stressed from an angle that the construction of the appliance permits.

48 Abnormal Heating Test

48.1 General

48.1.1 If the conditions of normal operation are not representative of abnormal conditions that can occur in actual service, an appliance shall not present a risk of fire or electric shock when operated continuously under such abnormal conditions.

48.1.2 The functioning of an overcurrent-protective device provided for a motor, whether or not such a device is required, shall not result in a risk of fire, electric shock, or injury to persons. See 34.1.6.

48.1.3 When operated under the abnormal conditions described in 48.2.1, an appliance is considered to involve a risk of fire if there is any emission of flame or molten metal, or if operation of the appliance results in the glowing or flaming of combustible material upon which the appliance may be placed or on adjacent wall surfaces.

48.1.4 An appliance is considered to involve a risk of electric shock if the fuse in the grounding connection opens.

Exception: The fuse in the grounding connection may open if the appliance:

- a) Is provided with a grounding conductor,*
- b) Is cord connected,*
- c) Is rated 120 volts, 20 amperes or less,*
- d) Is not normally hand held by persons and any gripping areas, such as a handle, dispensing tap, and the like are made of a material other than metal,*
- e) Has dead metal parts that will not normally be in contact with other metal surfaces when used, and*
- f) Complies with 48.2.6 and 48.2.7.*

48.1.5 If an appliance employs oil or grease in its normal cooking operation, or if oil or grease can accumulate as a result of intended use of the appliance, neither normal nor abnormal conditions of use shall result in sparks, flareups, and the like that will ignite the reservoir of oil or grease.

48.1.6 A thermal cutoff shall not open during the abnormal heating tests.

Exception No. 1: A thermal cutoff may open in a coffee maker or similar appliance during operation without water.

Exception No. 2: A thermal cutoff, the opening of which requires replacement of a subassembly, such as a heating element, may open during the abnormal heating test.

48.2 Test Procedure

48.2.1 To determine whether a risk of fire or electric shock exists, a separate burnout or abnormal heating test is to be conducted with the appliance operating continuously until the ultimate result has been determined. Unless otherwise indicated, the test is to be conducted with the applied voltage, method of mounting, and thermostat setting in accordance with 45.3.2, 45.3.3, 45.3.8, and 45.4.5 – 45.4.27, except that a grounding conductor of a supply cord or other connection is to be disconnected. Exposed dead metal parts are to be connected to ground through a 3-ampere fuse. In most cases, continuous operation for 7 or 8 hours will be necessary to make sure that the ultimate result has been observed.

48.2.2 The variety of appliances is such that it is impractical to detail the test conditions representing abnormal operation of every type of appliance. However, some specific examples of such test conditions are given in 48.2.3 – 48.2.16.

48.2.3 COFFEE MAKERS – The coffee maker is to be operated continuously without water with the thermostat set to give maximum temperature.

48.2.4 DEEP-FAT FRYERS – The fryer is to be operated with the oil at various levels and with only a residual film of oil on the container. The regulating thermostat is to be adjusted to the maximum temperature setting and the limiting control is to remain in the circuit, functioning. Each test is to be started with the appliance at room temperature and operation is to be continued until it has been determined that ignition of the oil is unlikely. The element or elements may be dry or covered with a film of oil. Ignition of the oil in the reservoir is not acceptable, but flaming of oil or carbon on the element or clamp is acceptable. These tests are also to be conducted with any one of the fuses or circuit breakers used to comply with the requirements in 21.9 opened. A control shall de-energize the appliance before the temperature in the center of the oil pool exceeds 246°C (475°F), and overshoot shall not result in ignition of the oil. If the limiting control operates during the test, the test described in 45.4.10 is to be repeated.

48.2.5 Each series of tests is to be started with unused vegetable oil. New oil is to be added as required to raise the level for successive tests but the used oil in the deep-fat fryer is not to be replaced between tests. The thermocouple for measuring the oil temperature is to be placed in the center of the pool of oil, 1 inch (25.4 mm) below the surface.

Exception No. 1: For oil depths of less than 2 inches (50.8 mm), the thermocouple is to be placed at a point equal to half the depth of the oil.

Exception No. 2: For a thermocouple location that would be on or immediately above a heating element, the thermocouple is to be placed approximately in the center of the pool but between elements; and for depths less than 2 inches above the elements, halfway between the elements and the surface.

Exception No. 3: No temperature measurement is to be made with only a residual film of oil on the container.

48.2.6 With reference to the exception to 48.1.4, the fuse mentioned may open if the appliance is then subjected to the procedures described in 48.2.7 and complies with (a) – (e).

- a) The leakage current measured in accordance with the Leakage Current Test, Section 40, shall not exceed 0.5 milliamperes immediately following the grounded condition and until the product returns to ambient conditions.
- b) The dielectric voltage-withstand test, conducted in accordance with the Dielectric Voltage-Withstand Test, Section 42, shall show acceptable results when tested for 1 minute within 15 minutes of the grounded condition.
- c) The voltage across the 1.0 ohm resistor and the 500 ohm resistor in the tests described in (a) and (b) of 48.2.7 shall not exceed 30 volts rms for the duration of the short circuit condition.
- d) The duration of the ground fault shall not exceed 10 seconds; and if the line fuse opens, the ground fault shall not exist after the line fuse opens.
- e) There shall be no emission of flame or molten metal, or glowing or flaming of the combustible material upon which the appliance may be placed or on adjacent wall surfaces.

48.2.6 revised November 4, 1993

48.2.7 With regard to 48.2.6, the two test procedures are as follows:

a) The test described in 48.2.1 is to be repeated, except exposed dead metal parts are to be connected to ground without a fuse. The duration of the ground fault condition is to be indicated by a low impedance current indicator through a 1.0 ohm resistance and the voltage across the resistance is to be monitored. Nontime delay line fuses rated 20 amperes are to be placed in the supply circuit, unless the product is marked for time delay fuses, in which case time delay fuses are to be used.

b) The test described in 48.2.1 is to be repeated, except exposed dead metal parts are to be connected to ground through a 500 ohm resistance. The duration and magnitude of the ground fault condition is to be indicated by a high impedance voltage indicator. Nontime delay line fuses rated 20 amperes are to be placed in the supply circuit, unless the product is marked for time delay fuses, in which case time delay fuses are to be used.

48.2.8 HOT FOOD RECEPTACLES FOR STEAM TABLES – The appliance is to be operated continuously without water and with the switch or thermostat set to give maximum temperature.

48.2.9 OPEN BROILERS – The broiler is to be operated continuously with the controls set for maximum temperature. The grease pan is to be one-half full of lard at the start of the test. When temperatures have stabilized, commercial beef patties, 4 inches (100 mm) in diameter by 1/2 inch (13 mm) thick, are to be broiled. A sufficient number of patties are to be broiled, two or three at a time to determine that ignition of the lard is unlikely. The beef patties are not to be pressed or mashed deliberately while cooking on the grill. Any instructions for adding water or similar materials to the grease pan or fat receptacles are to be disregarded. Flare-ups from the griddle surface or meat during broiling or manipulation of the beef patties is to be disregarded, but ignition of the grease in the grease pan is not acceptable.

48.2.10 POPCORN MACHINES – The machine is to be operated with an automatic temperature-regulating or -limiting control or other protective device shunted out of the circuit unless its reliability has been determined as described in 49.2.1 and 49.2.2. However, no abnormal test is to be conducted on the popping kettle itself.

48.2.11 RANGES – The range is to be operated continuously as described in 45.4.19 except that the heat controls or switches are to be set to give the highest temperature.

48.2.12 GRIDDLES – If the temperature control permits a surface temperature higher than 275°C (527°F), the griddle is to be operated continuously under the same conditions described in 45.4.20 but with the heat controls or switches set to give the highest temperature on each griddle plate.

48.2.13 SANDWICH TOASTERS AND GRILLS – The toaster or grill is to be operated dry and with the cover – if any – closed.

48.2.14 TABLE STOVES – The stove is not be operated continuously with each heating unit covered with a circular stove plate as described in 45.4.19.

48.2.15 TOASTERS – The toaster is to be operated without toast and with doors or the equivalent closed.

48.2.16 WAFFLE IRONS – The waffle iron is to be operated dry and with the cover closed.

49 Endurance Test

49.1 Wiring

49.1.1 An appliance in which the normal cooking or cleaning function causes movement of electrical wiring or other insulated live parts shall withstand an endurance test as described in 49.1.2 and 49.1.3. There shall be no electrical or mechanical malfunction of the appliance and, after the endurance test, the appliance shall comply with the requirements for dielectric voltage withstand in the Dielectric Voltage-Withstand Test, Section 42.

49.1.2 The endurance test required by 49.1.1 is to consist of:

- a) 30,000 cycles of operation for an appliance such as a waffle iron, in which the movement of electrical parts occurs during the intended cooking operation; or
- b) 6000 cycles of operation for an appliance in which the movement occurs only during a cleaning operation.

49.1.3 For the endurance test described in 49.1.2, any mechanical arrangement may be employed to operate the movable member at a rate of approximately 12 cycles per minute. The cover or movable member is to be operated so that it will reach the limits of travel in both directions during each cycle.

Exception: For an appliance, such as a sandwich toaster, that has two different stop positions for the hinged cover, 5000 operations of the 30,000 total are to be with the cover moved to the wide open position. The appliance is to be operated at a reduced voltage or with resistors in series with the supply circuit so that the temperature produced on the grid will be 210°C (410°F).

49.2 Temperature Control

49.2.1 A temperature control shall be subjected to an endurance test consisting of the number of cycles specified in Table 49.1. A temperature control that is not covered in Table 49.1 shall be subjected to an endurance test consisting of the number of cycles of operation specified in Table 49.2.

Table 49.1
Endurance test for temperature controls

Type of Control	Number of Cycles
A manually reset limiting control in a deep-fat fryer that functions during the test described in 45.4.9 and that does not break a load when functioning	30,000
A temperature-regulating control of an appliance that employs oil or grease in its intended cooking operation	100,000
A limiting control of the automatically reset type in a deep-fat fryer – see 20.2.1	100,000
A manually reset limiting control and a limiting-control-test switch on an appliance provided with both – see 20.2.6	30,000

Table 49.2
Number of cycles of operation for endurance test

Type of control	Automatic reset control	Manually reset control
Temperature-Regulating	A number of cycles equivalent to 1000 hours of normal operation of the appliance but not less than 30,000 cycles. However, the test may be omitted if, with the control short-circuited, no temperature higher than the limits specified in Table 45.1 are attained in a normal temperature test of the appliance.	To be made the subject of an investigation. No value is specified because of unlikely occurrence.
Temperature-Limiting	A number of cycles equivalent to 100 hours of operation of the appliance under any condition that causes the control to function but not less than 6000 cycles.	1000 cycles under load and 5000 cycles without load
Combination Temperature-Limiting and -Regulating	100,000 cycles if, with the control short-circuited, there is evidence of a risk of fire as mentioned in 48.1.1. If there is no evidence of a risk of fire under this condition, the control is to be tested as described above for a temperature-regulating control.	To be made the subject of an investigation. No value is specified because of unlikely occurrence.

49.2.2 The endurance test requirements also apply to a magnetic contactor or other auxiliary equipment, used in connection with a temperature control.

50 Motor Switches Test

50.1 A switch that controls a motor and that does not have a horsepower rating for that motor shall perform acceptably when subjected to an overload test consisting of 50 cycles of making and breaking the stalled-rotor current of the motor. There shall be no electrical or mechanical malfunction of the switch, nor any undue pitting or burning of the contacts.

50.1 revised November 4, 1993

50.2 To determine whether a switch complies with the requirement in 50.1, it is to be tested with the rotor of the motor locked and with exposed dead metal parts of the appliance grounded. The appliance is to be connected to a supply circuit of rated frequency and maximum rated voltage. Electrical connections are to be such that a single-pole switch is connected in the ungrounded conductor of the supply circuit. An appliance intended for use on direct current is to be tested with a direct-current supply.

51 Thermal Cutoff Tests

51.1 A thermal cutoff that is depended upon to prevent a risk of fire or electric shock shall not be adversely affected by aging and shall open the circuit in the intended manner without causing the short-circuiting of live parts and without causing live parts to become grounded to the enclosure when the appliance is connected to a circuit of voltage in accordance with 45.3.8 or 45.3.9 and operated to cause abnormal heating. See 51.2.

51.2 To determine whether a thermal cutoff complies with the requirement in 51.1, the appliance is to be operated with other thermally-operated control devices in the appliance short-circuited as described in 20.1.3. During the test, the enclosure is to be connected through a 3-ampere fuse to ground.

52 Transformer Test

52.1 The overcurrent protection may be omitted from the primary of a transformer as specified in Exception No. 2 to 21.6 if, when the transformer is operated as described in 52.2 or 52.3:

- a) There is no emission of flame or molten metal from the enclosure of the appliance, and
- b) The fuse in the grounded connection does not open.

52.2 The circuit on which the transformer is tested is to be protected by fuses rated not less than that required for the appliance. Exposed dead metal parts are to be connected to ground through a 3-ampere fuse. Each accessible fuse provided with the transformer is to be replaced with a dummy fuse but inaccessible fuses are to remain in the circuit. The test voltage is to be as specified in 45.3.8 and at rated frequency. The load connected to the output terminals is to be as described in 52.3. Operation is to be continued until constant temperatures are indicated by a thermocouple on the transformer coil or until burnout occurs.

52.3 The burnout test is to be conducted with the output terminals of the transformer connected to a resistance of such value that three times the full-load-rated current will be drawn from the secondary winding, except that the output is to be short-circuited if such condition results in less than three times rated current being drawn from the secondary. The test may be conducted with the output terminals connected to a motor with the rotor locked. The load imposed on the transformer by the coil of any solenoid, relay, or the like – the largest of such devices if more than one is present – with its armature blocked open is to be determined. The test is to be conducted with an equal resistance load substituted for the coil.

53 Liquid Containers Test

53.1 If the deterioration of a liquid container, seal, tubing, or the like would result in a risk of fire or electric shock, the container, seal, or the like shall be investigated to determine that it is acceptably resistant to deterioration from the liquid intended to be used in contact with it.

53.2 The investigation for determining whether a part complies with the requirement in 53.1 depends upon the material of which it is composed, its size and shape, the mode of application in the appliance and other factors. The test procedure may include visual inspection – for detection of cracks, deformation, and the like – after artificial aging, as well as comparison of hardness, tensile strength, and elongation, before and after artificial aging.

53.3 A rubber or neoprene part, if tested to compare its tensile strength and elongation before and after artificial aging, is acceptable if these properties are found not to be less than the minimum values indicated in Table 53.1, corresponding to the temperature of the component during the normal temperature test.

Table 53.1
Artificial aging tests

Temperature on component during normal- temperature test	Artificial-aging procedure	Minimum acceptable percent of original (unaged) value for samples		Maximum change from unconditioned value (units)
		Tensile strength	Elongation	Indentation hardness
60°C (140°F) or less	Aged in oxygen bomb for 96 hours at 70.0 ±1.0°C (158.0 ±1.8°F) and 300 ±10 psig (2.1 ±0.1 Mpa)	60	60	±5
61 – 75°C (142 – 167°F)	Aged in oxygen bomb for 168 hours at 80.0 ±1.0°C (176.0 ±1.8°F) and 300 ±10 psig and in an air bomb for 20 hours at 127.0 ±1.0°C (261.0 ±1.8°F) at 80 ±3 psig (0.55 ±0.03 Mpa)	50	50	±5
76 – 90°C (169 – 194°F)	Aged in full-draft, circulating-air oven for 168 hours at 121.0 ±1.0°C (250.0 ±1.8°F)	50	50	10
91 – 105°C (196 – 221°F)	Aged in full-draft, circulating-air oven for 168 hours at 136.0 ±1.0°C (277.0 ±1.8°F)	50	50	10
Above 105°C (221°F)	Aged in air-circulating convection oven for 168 hours at 20°C (36°F) higher than the temperature attained in normal use	50	50	10

54 Abnormal Operation Test

54.1 A risk of fire or electric shock shall not develop when the circuit between any two terminals of any rectifier, transistor, or similar component is opened or short-circuited. If an appliance incorporates a capacitor, other than a motor-starting or motor-running capacitor, a risk of fire and electric shock shall not develop when the capacitor is short-circuited. Only one of these simulated fault conditions is to be imposed at one time.

Exception: The tests are to be omitted if one or both of the following conditions exist:

- a) *There is 10,000 ohms or more of additional series impedance in a circuit in which the voltage is 125 or less, or*
- b) *There is 20,000 ohms or more of additional series impedance in a circuit in which the voltage is more than 125 but is not more than 250.*

54.2 To determine whether an appliance complies with the requirement in 54.1, three complete tests are to be conducted under each of the following conditions using new components in each test. The appliance is to be connected to a power supply as indicated in 41.2.

- a) The plate and cathode terminals of an electron-tube rectifier are to be connected together. The test is to be repeated with only the cathode and heater terminals connected together if this condition was not represented by the first test.
- b) The terminals of a semiconductor rectifier are to be connected together.
- c) The terminals of an electrolytic filter capacitor are to be connected together.

54.3 An unacceptable condition is considered to exist if flame is emitted from the overall enclosure of the equipment, or if a permanent path is established between live parts and exposed metal.

54.4 Any malfunction, such as short-circuiting or changing of impedance of a pilot light or indicating lamp, shall not affect the proper functioning of a temperature-control system.

54.5 For the test required by 54.4, the series resistor of a gaseous discharge lamp is to be left in the circuit.

55 Permanence of Marking

55.1 A marking required to be permanent – durable and securely affixed – shall be molded, die-stamped, paint-stenciled, stamped or etched on metal, or indelibly stamped on pressure-sensitive labels secured by adhesive shall comply with the requirements in 55.2 – 55.5. Ordinary usage, handling, storage, and the like of the appliance shall be considered in determination of permanence of marking.

55.2 A pressure-sensitive label is considered to be permanent if immediately following removal from each test medium, and after being exposed for 24 hours to room temperature following removal from each test medium:

- a) Each sample demonstrates good adhesion and edges are not curled.
- b) The label resists defacement or removal as demonstrated by scraping across the test panel with a flat metal blade, 1/32 inch (0.8 mm) thick, held at a right angle to the test panel.
- c) The printing is legible and is not defaced by rubbing with thumb or finger pressure.

55.3 OVEN AGING TEST – Three sample labels applied to test surfaces as in the intended application are to be conditioned for 240 hours in an air oven maintained at the temperature specified in Table 55.1.

Table 55.1
Temperatures, oven-aging

Maximum temperature during normal temperature test of surface to which applied		Oven temperature	
°C	°F	°C	°F
60 or less	140 or less	87	189
80 or less	176 or less	105	221
100 or less	212 or less	121	250
125 or less	257 or less	150	302
150 or less	302 or less	180	356
Over 150	302	a	a

^a A label that is applied to a surface attaining a temperature greater than 150°C (302°F), during the normal temperature test, is to be oven-aged at a temperature representative of the temperature attained by the appliance during normal and abnormal operation.

55.4 IMMERSION TESTS – Six sample labels applied to test surfaces as in the intended application are to be conditioned for 24 hours in a controlled atmosphere maintained at $23 \pm 2^\circ\text{C}$ ($73 \pm 4^\circ\text{F}$) and at a 50 ± 5 percent relative humidity. Three of the samples are then to be immersed in water and the other three samples are to be immersed in oil at a temperature $21 \pm 2^\circ\text{C}$ ($70 \pm 4^\circ\text{F}$) for 48 hours in each case.

55.5 STANDARD ATMOSPHERE TEST – Three sample labels applied to test surfaces as in the intended application are to be conditioned for 72 hours in a controlled atmosphere maintained at $23 \pm 2^{\circ}\text{C}$ ($73 \pm 4^{\circ}\text{F}$) and at a 50 ± 5 percent relative humidity.

55.6 UNUSUAL-CONDITION EXPOSURE TEST – If a label is exposed to unusual conditions in service, three sample labels applied to test surfaces as in the intended application are to be conditioned for 24 hours in a controlled atmosphere maintained at $23 \pm 2^{\circ}\text{C}$ ($73 \pm 4^{\circ}\text{F}$) and at a 50 ± 5 percent relative humidity. The samples are then to be immersed for 48 hours in a liquid representative of service use maintained at the temperature the liquid would attain in service, but not less than $23 \pm 2^{\circ}\text{C}$.

MANUFACTURING AND PRODUCTION TESTS

56 Dielectric Voltage Withstand

56.1 Each appliance shall withstand without electrical breakdown, as a routine production-line test, the application of a potential at a frequency within the range of 40 – 70 hertz:

- a) Between the primary wiring, including connected components, and accessible dead metal parts that are likely to become energized, and
- b) Between primary wiring and accessible low-voltage – 42.4 volts peak or less – metal parts, including terminals.

56.2 The production-line test shall be in accordance with either Condition A or Condition B of Table 56.1.

Table 56.1
Production-line test conditions

Appliance rating	Condition A		Condition B	
	Potential, volts	Time, seconds	Potential, volts	Time, seconds
250 volts or less	1000	60	1200	1
Rated more than 250 volts	$1000+2V^a$	60	$1200+2.4V^a$	2

^a Maximum rated voltage.

56.3 The test equipment is to include a 500-volt-ampere or larger capacity testing transformer having an essentially sinusoidal adequate output, a means of indicating the test potential, an audible or visual indicator of electrical breakdown, and either a manually reset device to restore the equipment after electrical breakdown or an automatic reject feature of any unacceptable unit. Other arrangements may be considered and accepted if found to achieve the results contemplated.

56.4 A 500-volt-ampere or larger-capacity transformer need not be used in tests by the manufacturer if the transformer is provided with a voltmeter to directly measure the applied output potential.

57 Grounding Continuity

57.1 Each cord-connected appliance shall be tested as a routine production-line test to determine that continuity exists between the grounding blade of the attachment plug and the exposed dead metal parts described in 11.6.

57.2 Any indicating device such as an ohmmeter, a low-voltage battery-and-buzzer combination, or the like may be employed to determine compliance with the grounding continuity requirement in 57.1.

58 Limiting Controls

58.1 Each finished deep-fat fryer shall be tested to determine that the limiting control – see 20.2.1 – functions before it leaves the factory. The test may be conducted by any convenient method, such as by shunting the regulating control with oil in the fat container, by applying a separate source of heat to the sensing portion of the limiting control, or the equivalent.

Exception: The test is not required if the limiting control is of such design that damage to the bulb and capillary results in a permanent open circuit.

59 Pressure Vessels And Parts Subject To Pressure

59.1 Unless it is certified by the American Society of Mechanical Engineers (ASME) and eligible to be covered by the National Board of Boiler and Pressure Vessel Inspectors, each pressure vessel and pressure-relief device shall be examined and tested as specified in 59.2 – 59.4 to determine that it is acceptable.

59.2 Each pressure vessel shall be visually examined to determine that the welds, pipe connection fittings, and general assembly details are acceptable. Each weld shall be continuous, smooth, uniform, and with penetration and fusion for its entire length. The weld shall be free of scale or slag, and without voids or impurities, undercuts, overlaps, abrupt ridges, or valleys.

59.3 Each pressure vessel shall withstand a pressure of 1-1/2 times the maximum marked pressure of the vessel. The pressure is to be gradually increased to the specified test value. The vessel is not acceptable if it ruptures or leaks during the test.

59.4 Each automatically reset pressure-relief device shall be tested at its marked setting to determine that it functions as intended. The device is to be tested with air or a similar pneumatic source. See 61.9.

RATING

60 Details

60.1 An appliance shall be rated in volts, amperes or watts, and frequency. The rating shall include the number of phases if the appliance is designed for use on a polyphase circuit.

Exception: In place of a frequency rating, an appliance may be rated ac, if it does not contain a component such as a motor, relay coil, or other control device for which a specific frequency rating is required.

60.2 The voltage rating shall be in accordance with any appropriate single voltage or range of voltages such as 100 – 120, 208, 220 – 240, 254 – 277, 416, 440 – 480, 550, 575, and 600.

60.3 A nominal 208 volt single or three phase, or a 120/240 volt single-phase appliance is considered to involve a potential to ground of less than 150 volts. A two-wire, single-phase, or a three-wire, three-phase appliance with a rating in the range from 220 – 240 volts is assumed to involve a potential to ground of more than 150 volts.

Exception: Appliances marked in accordance with 61.12, 61.13, 62.15, or 62.16.

60.4 An appliance intended for alternating current only or direct current only shall be rated accordingly.

60.5 The added load that may be imposed on an appliance and its supply connections by an attachment-plug receptacle that serves as a general-use outlet – 1440 watts if a 15-ampere receptacle is employed and 1920 watts if a 20-ampere receptacle is employed, unless the receptacle is marked for a specific load – shall be taken into consideration in determining the electrical rating of the appliance.

MARKING

61 Visible After Installation

61.1 The marking required by 61.2 – 61.18 shall be durable and securely affixed to the appliance and shall be plain, legible, and readily visible after the appliance is installed in the intended manner.

61.2 An appliance shall be marked with:

- a) The manufacturer's name, trade name, trademark, or other descriptive marking by which the organization responsible for the product may be identified – hereafter referred to as the manufacturer's name;
- b) A distinctive catalog number or the equivalent;
- c) The electrical rating; and
- d) The date or other dating period of manufacture not exceeding any three consecutive months.

Exception No. 1: The manufacturer's identification may be in a traceable code if the appliance is identified by the brand or trademark owned by a private labeler.

Exception No. 2: The date of manufacture may be abbreviated or in a nationally accepted conventional code or in a code affirmed by the manufacturer, provided:

- a) The date code does not repeat in less than 20 years.*
- b) The date code does not require reference to the manufacturer's records to determine when the product was manufactured.*

61.3 If the currents in ungrounded supply lines differ to such an extent that proper overcurrent protection would require fuses of different current ratings, the marking shall include the ampere rating of each ungrounded supply line.

61.4 If a manufacturer produces or assembles appliances at more than one factory, each finished appliance shall have a distinctive marking, which may be in code by which it may be identified as the product of a particular factory.

61.5 If it is necessary that the spacing between a permanently connected appliance and an adjacent surface, including a surface toward which heat is directed below a food warmer, not less than a certain distance to provide working clearance – see 10.2.4 – or to prevent the attainment of any temperature rise of more than 65°C (117°F) on that surface during normal operation, the appliance shall be marked, "Do not install closer than ... inches to a back wall (side wall, warming surface, etc. ...)" as may be necessary to indicate all such minimum spacings.

61.6 In lieu of the marking required by 61.5, a permanently-installed radiant-heat food warmer may be marked with the word: "WARNING" and the following or the equivalent: "To avoid burning or charring of materials in the surface below the food warmer, use only above an all metal structure such as a table or counter top. For other materials, install not closer than ... inches above the surface."

61.7 An appliance having provision for permanent connection to multiple power supplies shall be marked with the word: "CAUTION" and the following or the equivalent: "This appliance has more than one power-supply-connection point. Disconnect all power supplies before servicing," or the appliance shall be marked as specified in 62.14.

61.8 An appliance that incorporates a part subject to pressure shall be marked to specify the maximum working pressure.

61.9 A pressure-relief device on an appliance shall be marked to specify the setting of the device.

61.10 An appliance rated more than 15 amperes and having an attachment plug rated less than 125 percent of the current rating of the appliance shall be marked: "For use on individual branch circuit only" or the equivalent.

61.11 An appliance rated more than 16 amperes, intended for permanent connection to a 20 ampere branch circuit shall be marked: "For use only on an individual branch circuit rated 20 amperes."

61.12 A two-wire, 220 – 240 volt cord-connected appliance intended for connection to a circuit operating at 150 volts or less to ground shall be marked: "Do not connect to a circuit operating at more than 150 volts to ground" or with equivalent wording.

61.13 A three-wire, three-phase, 220 – 240 volt cord-connected appliance intended for connection to branch-circuit conductors operating at 150 volts or less to ground shall be marked: "Do not connect to a circuit operating at more than 150 volts to ground" or with equivalent wording. The marking shall identify the plug pins that are to be supplied by circuit conductors of 150 volts or less to ground.

61.14 The ampere rating of fuses that are used for the overcurrent protection mentioned in 21.6 – 21.10 shall be marked on an appliance so that it is obvious to which fuse and fuseholder the rating applies. In addition, an appliance shall be prominently marked with the word "WARNING" and the following or the equivalent: "For continued protection against fire and electric shock, replace with ____ ampere fuse." A single marking is acceptable for a group of fuses.

Exception: The warning marking is not required if the fuseholder is of a type that will not accept a fuse of a higher ampere rating.

61.15 A fryer provided with a limiting-control test switch – see 20.2.6 – shall be marked with the following or its equivalent:

- a) Instructions to preheat the oil to maximum temperature before using the test switch;
- b) A maximum time that the test switch should be held and what occurs to indicate that the limiting control has functioned;
- c) A caution marking indicating what action is to be taken if the limiting control does not function properly; and
- d) A recommended time interval for conducting the tests, such as weekly, monthly, or the like.

61.16 With reference to 7.1.8, a compartment with a key-locked cover and no user-serviceable parts shall be marked "CAUTION" and the following or the equivalent: "To reduce the risk of electric shock, do not remove or open cover. No user-serviceable parts inside. Refer servicing to qualified personnel." The marking shall be located on or adjacent to the cover of the compartment.

61.17 An electrical accessory intended for field installation in or on an appliance shall be marked with the name or identifying symbol of the manufacturer or private labeler, with a catalog number or equivalent with which it is intended to be use. The appliance shall be marked to indicate the catalog number or equivalent designation of such an accessory and the name of the manufacturer or private labeler of that accessory.

61.18 With reference to 61.17, instructions for installing the accessory shall be provided on or with the accessory. A statement shall be included in the instructions warning the user to disconnect the appliance from the electrical supply before attempting the installation and that the accessory is intended for use only with the appliance that is marked to indicate such use.

62 Visible During Installation And Examination

62.1 The marking required by 62.2 – 62.17 shall be durable and securely affixed to the appliance and, except as provided in 62.8 – 62.14, shall be plain, legible, and readily visible during installation and examination of the supply-wiring connections.

62.2 An appliance intended for use with a device that is shipped separately in accordance with Exception No. 5 to 9.2.1 shall be marked with the manufacturer's name and model designation of the device.

62.3 If, during the temperature test, any point within a terminal box or wiring compartment of a permanently-connected appliance in which field-installed conductors are intended to be connected, including such conductors themselves, attains a temperature rise of more than 35°C (63°F), the appliance shall be marked with the wire size in accordance with 62.4 and with the wire temperature rating in accordance with 62.5 for example: "For supply connections use No. ... AWG wires suitable for at least ...C (...F)."

62.4 The marking of wire size required by 62.3 depends on the size of the supply conductors employed for the temperature test. See 45.2.1.

- a) If the normal temperature test is conducted using conductors of more than one size because of unbalanced loads, multiple power supplies, or other reasons, the marking is to include the following statement or equivalent: "See wiring diagram for wire size."
- b) If the normal temperature test is conducted using conductors all of the same size, the marking is to specify that size.
- c) If the normal temperature test is conducted using No. 14 AWG (2.1 mm²) conductors, the wire size marking may be omitted.

62.5 The marking of the temperature rating of the supply conductors required by 62.3 depends upon the temperature rise in the terminal box as specified in Table 62.1.

Table 62.1
Supply-conductor-temperature marking

Temperature rise attained in terminal box or compartment during test	Temperature marking
35°C or less (63°F)	None required
36 – 50°C (64 – 90°F)	75 C (167 F)
51 – 65°C (91 – 117°F)	90 C (194 F)

62.6 The appliance shall be marked with information for the installation and examination of the connections unless the proper connection to field-wiring terminals is obvious; for example, phase changing, terminal current or potential rating, multiple supplies, and the like. If unbalanced supply currents exist as indicated in 61.3, each supply terminal shall be marked with its current rating.

62.7 An appliance having components that are to be connected in the field shall be provided with markings indicating the location of the field connections and any specific requirement for the point of connection, such as the need for moisture-resistant wire insulation, the size of conductor, or temperature rating.

62.8 An appliance incorporating an incandescent lamp shall be marked, immediately adjacent to the lampholder, to specify the maximum lamp wattage if:

- a) The lamp is intended as a source of heat for the appliance.
- b) Use of a higher wattage lamp would increase the input to the appliance to more than 105 percent of the appliance rating, or
- c) Heat from the lamp would affect the temperature of wiring or other components to which a temperature limit applies.

62.9 If, because of wiring space or other factors, a terminal of the appliance is not acceptable for use with aluminum wire, the appliance shall be marked: "Use copper wire only for power-supply connections."

62.10 If the wiring space and other factors are such that all terminals of the appliance are acceptable for use with aluminum and copper wire, the appliance shall be marked "Use copper or aluminum wire for power-supply connections."

62.11 An appliance equipped with auxiliary-circuit terminals shall be marked to specify the volt and volt-ampere rating of the contactor coil controlled by connection to the terminals.

62.12 A heating element rated more than 1 ampere and intended to be replaceable in the field shall be marked with:

- a) Its rating in volts and amperes,
- b) Its rating in volts and watts,
- c) The manufacturer's part number, or
- d) Other equivalent means of identification.

62.13 If replacing a lamp or fuse, resetting a circuit breaker or resetting a manually reset thermostat exposes persons to unintentional contact with normally enclosed live parts – see 7.2.1 – the appliance shall be marked to indicate plainly that such servicing is to be performed only while the appliance is electrically disconnected from the branch-circuit supply. The marking shall be on or adjacent to every door or cover that requires opening.

62.14 If an appliance having provision for permanent connection to multiple power supplies is not marked in accordance with 61.7, the specified marking shall be on all covers on the appliance that give access to live parts.

62.15 A two-wire, 220 – 240-volt permanently-connected appliance intended for connection to a circuit operating at 150 volts or less to ground shall be marked "Do not connect to a circuit operating at more than 150 volts to ground" or with equivalent wording.

62.16 A three-wire, three-phase, 220 – 240-volt permanently connected appliance intended for connection to branch-circuit conductors operating at 150 volts or less to ground shall be marked: "Do not connect to a circuit operating at more than 150 volts to ground" or with equivalent wording. The marking shall identify the leads or terminals that are to be supplied by circuit conductors of 150 volts or less to ground.

62.17 A permanently-connected appliance having one motor and other loads or more than one motor with or without other loads shall be marked with:

- a) The minimum supply-circuit conductor ampacity based on the maximum input in accordance with 41.2; and, the maximum rating and type – for example, nontime-delay fuse dual-element time-delay fuse, and the like – of supply-circuit overcurrent-protective device in accordance with 21.4; or

Exception: An appliance in which both the minimum circuit size and maximum rating of the circuit overcurrent-protective device are not more than 15 amperes.

- b) The rating of the largest motor in volts and amperes, and the additional load in volts and amperes, or volts and watts.

Exception: The ampere rating of a motor rated 1/8 horsepower (94 W output) or less or a nonmotor load of 1 ampere or less may be omitted unless such loads constitute the principal load.

62.18 If the surface on which a floor-mounted permanently-connected appliance is mounted has a maximum temperature rise between 66°C (118°F) and 125°C (225°F) (see Table 45.1, item 2), the appliance shall be marked with the word "WARNING" and the following or the equivalent: "To reduce the risk of fire, install appliance on a concrete or masonry base, or on a (manufacturer's name), Model _____ base."

62.19 If the surface on which a floor-mounted, permanently connected, fixed oven is mounted has a temperature rise greater than 65°C (117°F) (see item 2 of Table 45.1), the appliance shall be marked "CAUTION USE ONLY ON SPECIALLY CONSTRUCTED NONCOMBUSTIBLE FLOORS. SEE INSTALLATION INSTRUCTIONS." See 64.3.

63 Nonpermanent Marking

63.1 The marking required by 63.2 and 63.3 shall be attached to the appliance and shall be plain, legible, and readily visible, but except as noted, need not be permanent.

63.2 If the legs or mounting brackets of an appliance are necessary to comply with performance requirements – for example, normal temperature tests – or constructional requirements – for example, to allow inspection of field wiring connection – the appliance shall bear a marking cautioning against using the appliance without the legs or brackets unless the legs or brackets are in place when the product is shipped. The marking shall be permanent if the appliance may be removed from the legs or brackets without tools after assembly in the intended manner.

63.3 An appliance provided with factory installed flexible metal conduit with leads in accordance with 10.1.4 shall be marked to indicate that the flexible metal conduit and leads are factory installed.

64 Manufacturer's Literature

64.1 If an appliance is not completely assembled when shipped from the factory, in accordance with Exceptions No. 2 – 4 to 9.2.1, information concerning each of the separate parts shall be provided in the installation instructions to indicate the other parts that are intended for use with each separate part.

64.2 Installation instructions for an appliance tested in accordance with 45.3.4 shall include each combination of adjacent mountings with which the appliance may be used.

64.3 If the appliance is required to be marked in accordance with 62.19, the installation instructions, operating manual, and advertising literature supplied with or in conjunction with the appliance shall contain the following: "CAUTION – To reduce the risk of fire, the appliance is to be mounted on floors of noncombustible construction with noncombustible flooring and surface finish and with no combustible material against the underside thereof, or on noncombustible slabs or arches having no combustible material against the underside thereof, such construction shall in all cases extend not less than 12 inches beyond the equipment on all sides." The installation instructions shall specify and show the floor construction necessary to comply.

64.4 The installation instructions, operating manuals, and advertising literature supplied with or in conjunction with an appliance shall not recommend any procedure that might result in a risk of fire, electric shock, or injury to persons.

No Text on This Page

**SUPPLEMENT SA - COMMERCIAL ELECTRIC COOKING APPLIANCES FOR USE UNDER USCG,
ELECTRICAL ENGINEERING REGULATIONS SUBCHAPTER J (46 CRF, PARTS 110 – 113)****COOKING APPLIANCES FOR MARINE USE****SA1 Scope**

SA1.1 These requirements cover commercial electric cooking appliances intended for use aboard vessels more than 65 feet in length as covered by the referenced regulations. These requirements supplement the applicable requirements in Sections 1 – 64.

SA2 Cleaning and Maintenance

SA2.1 It shall not be necessary to use a tool to gain access to any area or space that requires routine cleaning.

SA2.2 Components in an appliance shall be located so that access for servicing or replacement will not be unduly restricted.

SA2.3 The need to lift or remove a heavy part, such as a griddle top, to gain access to component is not acceptable.

Exception: Heating elements and connecting wiring that are fastened to the griddle top.

SA3 Hinges and Locking Devices

SA3.1 A door hinge shall be of heavy duty construction. Each leaf of a hinge shall be reliably fastened to the enclosure or trim and to the door.

SA3.2 A locking device shall be provided for each door, drawer, or the equivalent to prevent unintentional opening as a result of vessel motion, including heavy seas.

SA4 Protection of Personnel

SA4.1 An appliance with exposed cooking surfaces such as a griddle plate, a surface element, an open-fat frying container, and the like shall be provided with grab rails. The rails shall be located so that they can be reached with either hand from the normal working position without reaching over the cooking surface.

SA4.2 An appliance intended to be used with separate cooking utensils shall incorporate sea rails with adjustable barriers to prevent unintentional movement of the utensil.

SA4.3 A fat container and the means to collect grease or oil specified in 6.3.1 shall not spill grease or oil from the appliance as a result of normal motion of the vessel.

SA4.4 Normal motion is considered to be conditions that prevail at 20 degrees roll and 5 degrees pitch.

SA4.5 A deep-fat fryer shall be provided with a readily accessible, manually operable switching device – which may be incorporated in the thermostat – that de-energizes the element or elements.

SA4.6 A deep-fat fryer provided with a heating element that may be raised above the normal operating position shall incorporate a reliable means, not subject to unintentional release during cleaning or motion of the vessel, that retains the element in the raised position until positive action is taken to release it.

SA4.7 Operation of a control – a switch, thermostat, manual reset button, and the like – of a deep-fat fryer shall not necessitate reaching over the fat container.

Exception: A deep-fat fryer may have its operating controls, such as a temperature control, a thermostat, manual reset button, and the like located such that it may necessitate reaching over the fat container only if an on/off switch that operates in accordance with 25.10 and a test switch (if provided) are located in a readily accessible position on the front of the deep-fat fryer.

SA4.7 revised June 2, 1993

SA5 Securing of Appliances

SA5.1 An appliance shall be provided with holes in the frame or the equivalent, to permit securing to the supporting surface.

SA6 Disconnecting Means

SA6.1 If an appliance incorporates a switch that is intended to serve as a disconnect, the switch:

- a) Shall be of such type and connected so that it will disconnect the appliance from all conductors of the power-supply circuit,
- b) Shall not be adversely affected by the heat of the appliance, and
- c) Shall be located so as to be accessible in the event of a fire on the cooking surfaces.

SA7 Marking

SA7.1 The switch described in SA6.1 shall indicate plainly whether it is in the open- or closed-circuit position.

SUPPLEMENT SB - COMMERCIAL ELECTRIC COOKING APPLIANCES WITH RECIRCULATING SYSTEMS

INTRODUCTION

SB1 Scope

SB1.1 These requirements cover commercial electric cooking appliances provided with integral recirculating systems (previously referred to as ductless hoods) and nonintegral recirculating systems, both of which are intended for installation in commercial establishments for the preparation of food. These devices incorporate an air filtering system enclosed in a hooded or otherwise contained area intended to capture air from the cooking process area. The hood assembly generally includes a fan, collection hood, or equivalent design feature, air filtering system (consisting of a grease filter with other filters), a fire actuated damper, and a fire extinguishing system unit. An integral recirculating system of a vending machine is also covered by this supplement.

Added SB1.1 effective April 29, 1997

SB1.2 These products are intended for installation in accordance with the Standard for Ventilation Control and Fire Protection of Commercial Cooking Operations, NFPA 96-1994.

Added SB1.2 effective April 29, 1997

SB1.3 The cooking section of the appliance shall comply with the requirements in Sections 2 – 64, as applicable, except as modified or superseded by the requirements in this Supplement.

Added SB1.3 effective April 29, 1997

CONSTRUCTION

SB2 Fire Extinguishing System Unit

SB2.1 A fire extinguishing system unit shall be provided and shall include all required wiring, piping, and discharge port(s) oriented for proper operation. The recirculating system shall have provisions for the following:

- a) Removal of the fire extinguishing system cylinder assembly and pressurizing cartridge (if provided) for maintenance and recharging; and
- b) External visibility of the pressure gauge to indicate the charge pressure for the stored pressure type extinguishing system units.

Added SB2.1 effective April 29, 1997

SB2.2 In addition to the appliance nozzle(s), there shall be a fire extinguishing nozzle installed immediately before or after the first grease filter, and between the last grease or odor filtration unit and the blower.

Added SB2.2 effective April 29, 1997

SB2.3 In addition to any other fire extinguishing system actuation device, there shall be a fire extinguishing system actuation device installed downstream of any electrostatic precipitator (ESP).

Added SB2.3 effective April 29, 1997

SB2.4 A deep fat fryer that develops a fire within the cabinet and below the vat during the Automatic Operation Fire Test, Section SB16, the Manual Operation Test, Section SB17, or the Fire Containment Test, Section 18, shall be provided with one or more extinguishing nozzles within these areas.

Added SB2.4 effective April 29, 1997

SB2.5 The fire extinguishing system unit shall comply with the applicable requirements of the Standard for Dry Chemical Extinguishing Systems, NFPA 17-1990 or the Standard for Wet Chemical Extinguishing Systems, NFPA 17A-1990 and the requirements specified in the Standard for Pre-Engineered Extinguishing System Units, UL 1254 or applicable requirements for other systems.

Added SB2.5 effective April 29, 1997

SB2.6 The extinguishing system pressure tank or piping shall include a pressure switch or other device located as close to the tank as practical and shall be electrically connected to the appliance so that actuation of the fire extinguishing system results in immediate shutdown of the cooking appliance heat source. A recirculating system provided with a different type of interlock (not a pressure switch) to affect shutdown of heating energy to the cooking appliance in the event of leakage or discharge of the extinguishing system shall be evaluated for equivalence to a suitably applied pressure switch.

SB2.6 revised February 18, 1998

SB2.7 The switch described in SB2.6 shall be one rated a minimum of 6000 cycles.

Added SB2.7 effective April 29, 1997

SB2.8 A means for manual actuation of the fire extinguishing system unit shall be provided in an area where it is readily accessible in the event of a fire in the appliance. Such means shall be mechanical and shall not rely on electrical power for actuation. See SB28.1 for the requirements covering the installation of such means.

Exception: A primary electrical means for manual actuation may be used if a battery backup system is provided. The battery backup system shall be provided with a visible means to indicate the condition of the battery. The battery backup system shall incorporate means to restrict the operation of the cooking appliance if the battery voltage drops below the minimum operating voltage of the backup system.

Added SB2.8 effective April 29, 1997

SB2.9 If the manual actuator described in SB2.8 is located on the appliance, the torque created by the actuation of the device shall not cause the unit to topple or move with the appliance at an angle of 10 degrees from the vertical.

Added SB2.9 effective April 29, 1997

SB3 Fire Actuated Damper Assemblies

SB3.1 A fire actuated damper shall be provided as part of the recirculating system, and it shall comply with all of the following requirements:

- a) A fire actuated damper shall be installed at the exhaust outlet of the system. The damper shall be constructed of at least the same gauge as the hood.
- b) A fire actuated damper assembly employing replacement parts, such as fusible links, shall be accessible without the use of special tools.
- c) The load on a fusible link used in a fire actuated damper assembly shall be in accordance with the intended use of the fusible link.
- d) A spring and a bearing used in the assembly of a fire actuated damper shall be of material having strength and resistance to atmospheric corrosion equivalent to an alloy containing not less than 85 percent copper or Type 302 or 430 stainless steel. In addition, a spring shall be of a material having spring properties equivalent to stainless steel conforming to Specification for Chromium-Nickel Stainless and Heat Resisting Steel Spring Wire, ASTM A313-87.

e) The materials used in the fire actuated damper assembly shall comply with SB5.1. The combination of metals used in the assembly of a damper shall not cause galvanic action that may impair the function of any part of the assembly.

Exception: The materials used for the dampers need not comply with SB5.1 if the damper complies with the Standard for Fire Dampers, UL 555.

Added SB3.1 effective April 29, 1997

SB4 Hood Assembly

SB4.1 Openings in the grease-air stream enclosure provided for passage of extinguishing system unit piping to the nozzle(s) or for passage of electrical conduit shall be provided with fittings that comply with either the Fire Containment Test, Section SB18, or the Fire and Leakage Test of Fittings, Nonwelded Seams, Doors and Panels Used in Grease-Air Stream Enclosures, Section SB23, with no evidence of the passage of flame or grease vapor through or around the fitting.

Added SB4.1 effective April 29, 1997

SB4.2 The grease-air stream enclosure shall have a liquid tight continuous external weld.

Exception: External seams and joints made with a fastening means other than a liquid tight continuous weld may be employed in hoods that have been subjected to the Fire Containment Test, Section SB18, with no evidence of the passage of smoke, flame, or vapor through the joint.

Added SB4.2 effective April 29, 1997

SB4.3 Gasket and sealant materials used in an exhaust hood, a damper assembly, and fittings for hood penetrations, that may be exposed to cooking smoke and vapor shall be subjected to Gasket and Sealant, Physical and Immersion Tests, Section SB22.

Exception: Sealants used for aesthetics and/or cleaning purposes need not comply with this requirement.

Added SB4.3 effective April 29, 1997

SB4.4 All closure panels that may be opened or removed and encompass airflow sections shall have interlocks that shall de-energize the heat source for the cooking appliance if the panels are not in place and fully sealed.

Added SB4.4 effective April 29, 1997

SB5 Hood Materials

SB5.1 The hood and other parts of an exhaust hood that serve to confine or convey the exhaust products, including dampers and structural parts, shall be made of materials equivalent in strength and fire resistance to Type 302 or 430 stainless steel not less than 0.037 inch (0.94 mm) or steel not less than 0.043 inch (1.09 mm) thick. Internal ferrous metal parts of the hood shall be made of one of the 300 or 400 series of stainless steel or provided with corrosion protection.

Added SB5.1 effective April 29, 1997

SB6 Hood Air Flow

SB6.1 A manually resettable device(s) rated at 6,000 cycles or an automatically resettable device(s) rated at 100,000 cycles, and for use as a safety interlock that is covered by the Standard for Limit Controls, UL 353, shall be provided after the last filter component to restrict operation of the cooking appliance, if air flow through the hood drops 25 percent below the system's normal operating flow or 10 percent below the lower air flow limit, whichever is lower. When an automatically resettable device(s) is used, it shall be part of a manually resettable circuit.

Added SB6.1 effective April 29, 1997

SB6.2 The minimum air flow to capture smoke and grease laden air shall be equal to or less than the lower air flow limit.

Added SB6.2 effective April 29, 1997

SB7 Air Filters

SB7.1 Electrostatic precipitator

SB7.1.1 If the hood section includes an electrostatic precipitator (ESP), it shall comply with the Standard for Electrostatic Air Cleaners, UL 867.

Added SB7.1.1 effective April 29, 1997

SB7.1.2 The power supply for an ESP shall be one in which the voltage falls off as the current draw of a short increases such as a ferro-resonant type transformer.

Added SB7.1.2 effective April 29, 1997

SB7.1.3 An appliance that utilizes an ESP shall include a sensor to verify the ESP performance is as designed or deactivate the heating portion of the cooking appliance, with no interruption of the power to exceed 2 minutes (loss of power for more than 2 minutes shall deactivate the heating portion of the cooking appliance). This shall be a manual reset device or circuit.

Added SB7.1.3 effective April 29, 1997

SB7.2 Interlocks

SB7.2.1 Interlocks shall be used on all air filters, including electrostatic precipitators, to determine if the air filters are in place and positioned as intended. If the air filter is not in place or positioned as intended, the interlock shall de-energize the heat source for the cooking appliance.

Added SB7.2.1 effective April 29, 1997

SB8 Odor Filters

SB8.1 If an odor filter is used, it shall have an interlock that disconnects the heat source for the cooking appliance if the filter is not in place or positioned as intended.

Added SB8.1 effective April 29, 1997

SB9 Grease Filters

SB9.1 A grease filter complying with the Standard for Grease Filters for Exhaust Ducts, UL 1046, shall be included as the first filter (in the direction of the air flow), and all grease captured shall drain into a container that does not have more than a 1 quart (0.95 l) capacity. Mesh filters shall not be used as a grease filter.

Added SB9.1 effective April 29, 1997

SB9.2 An interlock shall be used on the grease filter to determine if the grease filter is in place and positioned as intended. If the grease filter is not in place or positioned as intended, the interlock shall de-energize the heating section of the cooking appliance.

Added SB9.2 effective April 29, 1997

SB9.3 The grease filter shall be installed at an angle not less than 45 degrees from the horizontal and shall be tight-fitting.

Exception: If no grease drips off from the grease filters on the cooking appliance(s) during the Capture Test, Section SB13, the grease filter need not comply with this requirement.

Added SB9.3 effective April 29, 1997

SB10 Internal Wiring

SB10.1 The internal wiring of an exhaust hood shall not be routed in or through the exhaust plenum (area of hood behind the grease filter and containing other filters).

Exception No. 1: Wiring enclosed in rigid or flexible metal conduit need not comply with this requirement.

Exception No. 2: Wiring material routed in suitable conduit and that is connected to a limited energy circuit as defined in 27.2 of this standard and which is not a part of a safety circuit need not comply with this requirement.

Added SB10.1 effective April 29, 1997

SB11 Blower Motors and Other Electrical Components

SB11.1 Blower motors and other electrical components shall not be located in the air stream.

Exception: Totally enclosed motors and other electrical components enclosed in a manner equivalent to a totally enclosed motor need not comply with this requirement.

Added SB11.1 effective April 29, 1997

SB12 Power Supply Connections

SB12.1 The appliance shall be connected to the electrical power supply in accordance with the National Electrical Code, ANSI/NFPA 70-1993.

Added SB12.1 effective April 29, 1997

PERFORMANCE

SB13 Capture Test

SB13.1 The tests described in SB13.2 – SB13.5 shall be conducted while the unit is located in a draft free room and is operating at the lower air flow limit.

Added SB13.1 effective April 29, 1997

SB13.2 During cooking for maximum grease emission potential with food product determined in SB14.1.2, the cooking area will be observed for the presence of visible smoke and grease-laden air and the hood assembly shall completely capture all of the emission as determined by observation.

Added SB13.2 effective April 29, 1997

SB13.3 Vegetable frying oil shall be used to cook the frozen, unbreaded fries intended for use in a deep fat fryer or other appliance where cooking oil is commonly added to the process. For griddles, broilers, and other appliances intended to cook meat, meat cakes as specified in the Standard for Exhaust Hoods for Commercial Cooking Equipment, UL 710, shall be used. The cooking appliance surface temperature will be maximum as recommended in the manufacturer's instructions. The sample test arrangement may be provided if necessary with an observation window located in the test sample's plenum or air duct to permit the observation of flow within the sample.

Added SB13.3 effective April 29, 1997

SB13.4 If the device and cooking process restricts visibility due to the lack of cooking smoke and grease-laden air observed, a smoke generator may be used and positioned in the cooking area to establish a more visible means for conducting this test. Care in selecting the intensity of the smoke generator shall be exercised to reduce the risk of simulating a cooking process emission greater than is feasible considering the product design and its constraints.

Added SB13.4 effective April 29, 1997

SB13.5 During the test, there shall be no visible emission of smoke and grease-laden air from the air discharge port or any other part or joint in the hood assembly.

Added SB13.5 effective April 29, 1997

SB14 Emission Test

SB14.1 General

SB14.1.1 The tests described in SB14.1.2 – SB14.6.2 shall be conducted while the unit is operating at the lower air flow limit.

Added SB14.1.1 effective April 29, 1997

SB14.1.2 The type of product shall be meat cakes as specified in the Standard for Commercial Cooking Equipment, UL 710, for appliances such as griddles, broilers, and others intended to cook meat, or frozen, unbreaded fries for fryers, or specific products to be cooked by other appliances such as donut fryers. The amount of food product to be cooked shall be the maximum product capacity for the appliance.

Added SB14.1.2 effective April 29, 1997

SB14.1.3 Vegetable frying oil shall be used to cook the food load of a deep fat fryer.

Added SB14.1.3 effective April 29, 1997

SB14.1.4 The grease-laden effluent discharged at the exhaust outlet of the system shall be measured as described below which was derived from the U. S. Environmental Protection Agency (EPA) Test Method 202, Determination of Condensable Particulate Emissions From Stationary Sources – 1991.

Added SB14.1.4 effective April 29, 1997

SB14.1.5 The grease-laden effluent at the exhaust outlet of the system shall not exceed an average of 5.0 mg/m³ of exhausted air sampled at a maximum product capacity over a continuous 8 hour test cooking period.

Added SB14.1.5 effective April 29, 1997

SB14.2 Test apparatus

SB14.2.1 The sampling train is to consist of the following:

- a) A stainless steel probe nozzle with a sharp tapered leading edge. The size is to be suitable for isokinetic sampling.
- b) A glass mat filter without an organic binder.
- c) A stainless steel filter holder.
- d) A glass or teflon lined probe extension equipped with a heating system.
- e) A type S stainless steel pitot tube suitable for use with a manometer assembly.
- f) A temperature sensor which is to be attached to either the pitot tube or to the probe extension.

Added SB14.2.1 effective April 29, 1997

SB14.2.2 A system of four impingers, in an ice bath, shall be connected to the probe extension. Both the first and second impingers shall be of the Greensburg-Smith design with the standard tip.

Added SB14.2.2 effective April 29, 1997

SB14.2.3 A meter system shall consist of a vacuum gauge, leak free pump, thermometers, and a dry gas meter.

Added SB14.2.3 effective April 29, 1997

SB14.2.4 A barometer shall be used.

Added SB14.2.4 effective April 29, 1997

SB14.3 Sampling procedure

SB14.3.1 The preliminary set-up shall be constructed as follows:

- a) Construct a stack out of duct sheet metal which is to be used for sampling.
- b) Each of the first three impingers is to be filled with 100 ml deionized distilled water. The fourth impinger is to be filled with silica gel. The weight of each impinger is to be determined and recorded.
- c) Assemble the train^a.
- d) A pre-test leak check is to be conducted.
- e) Calibrate the system.

^aThe use of silicone grease is prohibited.

Added SB14.3.1 effective April 29, 1997

SB14.3.2 The sampling location shall be located at least eight stack diameters downstream and two stack diameters upstream from any flow disturbance. After this criteria is met and a circular stack is used, a minimum of eight traverse points are to be used.

Added SB14.3.2 effective April 29, 1997

SB14.3.3 A post-test leak check shall be conducted.

Added SB14.3.3 effective April 29, 1997

SB14.4 Sample handling

SB14.4.1 The glass-filter is to be removed using a pair of forceps and placed in a clean petri dish. The dish is to be sealed and labeled "sample bottle number one".

Added SB14.4.1 effective April 29, 1997

SB14.4.2 A sample of the acetone of the same volume that will be used to rinse-out the nozzle and probe is to be placed into a clean sample bottle, sealed, and labeled "sample bottle number two". The level of the liquid in the sample bottle is to be recorded.

Added SB14.4.2 effective April 29, 1997

SB14.4.3 The inside of the nozzle and probe is to be rinsed with acetone taking care to collect all the rinse material in a clean sample bottle. The sample bottle is to be sealed, labeled "sample bottle number three", and the level of the liquid in the bottle is to be recorded.

Added SB14.4.3 effective April 29, 1997

SB14.4.4 The liquid in the first three impingers is to be measured and the total volume is to be recorded which will be compared to the original volume. The liquid is to be quantitatively transferred to a clean sample bottle.

Added SB14.4.4 effective April 29, 1997

SB14.4.5 Each impinger and the connecting glassware including the probe extension is to be rinsed twice with water. The rinse water is to be collected and added to the same sample bottle. The sample bottle is to be sealed, labeled "sample bottle number four," and the level of the liquid in the bottle is to be recorded.

Added SB14.4.5 effective April 29, 1997

SB14.4.6 The rinses described in SB14.4.5 is to be followed with two rinses of methylene chloride (MeCl_2). The rinses are to be recovered in a clean sample bottle. The sample bottle is to be sealed, labeled "sample bottle number five" and the level of the liquid in the bottle is to be recorded.

Added SB14.4.6 effective April 29, 1997

SB14.4.7 A volume of water approximately equivalent to the volume of water used in SB14.4.5 and a volume of MeCl_2 approximately equivalent to the volume of MeCl_2 used in SB14.4.6 is to be placed in two clean sample bottles. The sample bottles are to be sealed, labeled "sample bottle number six" and "sample bottle number seven" respectively, and the level of the liquid in the bottles is to be recorded.

Added SB14.4.7 effective April 29, 1997

SB14.4.8 The fourth impinger containing the silica gel is to be emptied into a capped, sealed sample bottle and labeled "sample bottle number eight".

Added SB14.4.8 effective April 29, 1997

SB14.5 Analysis

SB14.5.1 The liquid level of all the sample bottles is to be measured.

Added SB14.5.1 effective April 29, 1997

SB14.5.2 The filter from sample bottle number one is to be removed and dried to constant weight by means of a desiccator or an oven. The weight of the filter is to be recorded.

Added SB14.5.2 effective April 29, 1997

SB14.5.3 The volume of sample bottle number two is to be determined. The liquid is then to be transferred to a beaker and evaporated to dryness. The volume of the liquid and the final weight of the condensable matter are to be recorded.

Added SB14.5.3 effective April 29, 1997

SB14.5.4 The volume of sample bottle number three is to be determined. The liquid is then to be transferred to a beaker and evaporated to dryness. The volume of the liquid and the final weight of the condensable matter are to be recorded.

Added SB14.5.4 effective April 29, 1997

SB14.5.5 The volumes of sample bottles number four and five are to be measured.

Added SB14.5.5 effective April 29, 1997

SB14.5.6 Sample bottles number four and five are to be combined. The organic phase is to be mixed, separated, and then repeated with two MeCl_2 washes.

Added SB14.5.6 effective April 29, 1997

SB14.5.7 The organic extracts obtained from the procedure in SB14.5.6 are to be placed in a beaker and evaporated to a constant weight. The final weight is to be recorded.

Added SB14.5.7 effective April 29, 1997

SB14.5.8 The inorganic phase is to be placed in a beaker and evaporated to dryness. The final weight is to be recorded.

Added SB14.5.8 effective April 29, 1997

SB14.5.9 The volumes of sample bottles number six and seven are to be determined. Sample bottles six and seven are to be analyzed according to SB14.5.8 and SB14.5.7 respectively.

Added SB14.5.9 effective April 29, 1997

SB14.5.10 The weight of sample bottle number eight (impinger and silica gel) is to be recorded.

Added SB14.5.10 effective April 29, 1997

SB14.6 Results

SB14.6.1 The average captured condensable particulate matter shall not exceed 3.1×10^{-7} lb/ft³ (5.0 mg/m³).

Added SB14.6.1 effective April 29, 1997

SB14.6.2 During the test, temperatures of the air flow and of various surfaces considered to be thermally hot during the cooking operation are to be measured. These temperatures shall not exceed 475°F (246°C).

Added SB14.6.2 effective April 29, 1997

SB14.6.3 Tests conducted on pressure fryers shall include operation of the sample in an open fryer mode with the access door remaining open during the test. If normal operation of the product in a pressure operating mode indicates this mode to be worse case in terms of visible emission, the test shall be conducted in both modes of operation.

Added SB14.6.3 effective April 29, 1997

SB15 Damper Tests

SB15.1 General *Reserved*

SB15.2 Cycling test *Reserved*

SB15.3 Closure test

SB15.3.1 With the unit operating at its maximum air flow and the damper's actuating device disabled, the damper is to be manually operated. The damper shall fully close as intended. This operation is to be conducted a total of three times.

Added SB15.3.1 effective April 29, 1997

SB16 Automatic Operation Fire Test

SB16.1 When tested as specified in SB16.2 – SB16.6, the extinguishing system unit shall detect and suppress the fire. The sample shall be monitored after actuation in accordance with the requirements in the Standard for Fire Testing of Fire Extinguishing Systems for Protection of Restaurant Cooking Areas, UL 300, to verify that re-ignition does not occur. When tested in accordance with SB16.5, the extinguishing system unit shall comply with the extinguishment splash test and the cooking temperature splash test as specified in UL 300.

SB16.1 revised February 18, 1998

SB16.2 If a fryer employs a removable cover that is used while the heater is energized, the following fire tests are to be conducted with the removable cover positioned to cause the worst case. The product shall be marked in accordance with SB25.2(d). The tests on a pressure fryer are to be conducted with its cover open during the test. If a pressure fryer can be operated with its cover partially open or closed (but not latched), the fire tests shall also be conducted in these modes of operation.

Added SB16.2 effective April 29, 1997

SB16.3 The ignition shall be accomplished by defeating all temperature controls in the cooking appliance section in order to self-ignite the grease or cooking oil. For deep fat fryers, this will generally occur when the cooking oil reaches a temperature in excess of 600°F (315.6°C). In each case, the hood air passageways and filters shall be coated with lard prior to this testing. The lard shall be applied with a density of 0.3 pound per square foot (1.5 kg/m²) or at the lesser density required to permit sufficient air flow to restrict the lower air flow control from functioning.

Added SB16.3 effective April 29, 1997

SB16.4 The extinguisher cylinder is to be pressurized to simulate the minimum storage temperature for the automatic operation fire test condition. The extinguishing system unit is to be allowed to operate automatically and the time between auto-ignition and unit actuation is to be determined.

Added SB16.4 effective April 29, 1997

SB16.5 The extinguisher cylinder is to be pressurized to simulate the minimum storage temperature for the extended operation fire test condition. The extinguishing system unit is to be actuated after a preburn of the time recorded for unit actuation during the automatic operation test plus 30 seconds.

Added SB16.5 effective April 29, 1997

SB16.6 After each fire test, the appliance shall comply with the Dielectric-Voltage Withstand Test, Section 42.

Added SB16.6 effective April 29, 1997

SB17 Manual Operation Test

SB17.1 When an extinguishing system employs an electrical means for manual actuation, it shall be tested in accordance with SB17.2. The extinguishing system shall actuate when the electrical means for manual actuation is powered from the battery backup system.

Added SB17.1 effective April 29, 1997

SB17.2 For this test, the extinguishing system shall be operated by the battery backup system with the primary electrical means for actuation bypassed. The battery voltage shall be at the minimum voltage level specified by the manufacturer and the extinguishing system is checked for proper operation when the electrical means for the manual actuation system is operated.

Added SB17.2 effective April 29, 1997

SB18 Fire Containment Test

SB18.1 During the automatic and extended operation fire test conditions in SB16.4 and SB16.5, the flaming generated in the cooking area and any flame that occurs in the filtering area, shall be contained within the hood or the periphery of the appliance bound by the hood and the cooking area including openings in the grease-air stream enclosure provided for passage of extinguishing system unit piping or for passage of electrical conduit that are provided with fittings. If the appliance is intended for use in combustible surroundings and for permanent connection to the electrical source of supply, the appliance shall be installed within a combustible alcove as described in 45.3.1 – 45.3.3 of this Standard at the manufacturer's designated minimum clearance(s). If the appliance is intended for use in non-combustible surroundings only, the appliance need not be installed within a combustible alcove.

Added SB18.1 effective April 29, 1997

SB18.2 The surface of a combustible alcove shall not exceed a temperature of 175°F (79°C) above ambient during the test.

Exception: After the fire has been completely extinguished, the temperature rise of the surface is not required to be less than 175°F when all of the following conditions are met:

- a) The fire was extinguished by only a wet chemical extinguisher;*
- b) The rise in temperature of the alcove surface is only due to the momentary heat release caused by the initial reaction of the wet chemical agent with the burning fuel;*
- c) The surface does not exceed a temperature rise of 175°F for more than one minute; and*
- d) There is no charring or other visible damage to the combustible alcove.*

SB18.2 revised February 18, 1998

SB18.3 During fire extinguishment, the flaming may momentarily escape the hood, cooking area, or both. However, the duration of this flaming shall not exceed 1 second.

Exception: Recirculating systems that correspond with SB18.5 need not comply with this requirement.

Added SB18.3 effective April 29, 1997

SB18.4 Reserved

SB18.5 Recirculating systems that comply with both of the following may exceed the flaming requirement specified in SB18.3:

- a) Recirculating systems that are permanently attached to the building structure, marked in accordance with SB25.5, and provided with the installation instructions in accordance with SB29.1; and
- b) Those recirculating systems in which the fire containment test is conducted with cotton pads placed around the appliance so that the cotton pads do not ignite when:
 - 1) Placed on the ceiling located at the height specified by the manufacturer as marked on the product in accordance with SB25.5; and
 - 2) Located away from the appliance at various heights at a clearance distance specified by the manufacturer as marked on the product in accordance with SB25.5.

Added SB18.5 effective April 29, 1997

SB18.6 The cotton pads shall consist of new undyed fibers without any mixture of artificial fibers and shall be free from thread, leaf, and shell fiber dust. The pads shall be 4 inches by 4 inches (10 cm by 10 cm) approximately 0.8 inches (2 cm) thick and weighing between 0.10 ounces and 0.14 ounces (3 and 4 grams). They shall be oven dried prior to the test. The pads shall be attached by means of noncombustible wire or clips.

Added SB18.6 effective April 29, 1997

SB19 Abnormal Flare Up, Fire, and Burn Out Tests

Reserved

SB20 Electrical Tests

SB20.1 The electrical and other test requirements specified in this standard shall apply to the hood assembly as well as to the cooking section of the device except where modified in this supplement.

Added SB20.1 effective April 29, 1997

SB20.2 The temperature at the heat responsive element during the Normal Operation Test, Section 45, shall not exceed the applicable requirements of the Standard for Heat Responsive Links for Fire-Protection Service, UL 33, and the Standard for Automatic Sprinklers for Fire-Protection Service, UL 199. The temperature of the air at the extinguisher unit is to be monitored during the Normal Operation Test. The temperature shall not exceed the maximum storage temperature for the extinguishing system unit.

Added SB20.2 effective April 29, 1997

SB21 Ozone Test

SB21.1 Equipment provided with electrostatic precipitators shall be tested for peak and time weighted average ozone levels.

Added SB21.1 effective April 29, 1997

SB21.2 The equipment is to be tested in the worst case with respect to ozone generation using new or clean filters. The test is to be conducted using all filters operational which generate ozone and by omitting those filters which are optional that reduce the overall output of ozone during the equipment operation.

Added SB21.2 effective April 29, 1997

SB21.3 The test is to be conducted in a 1000 ft³ (28.3 m³) closed room for a period of 8 h continuous operation. The maximum ozone levels permitted are 0.1 ppm time weighted average with a maximum peak concentration of 0.3 ppm.

Added SB21.3 effective April 29, 1997

SB22 Gasket and Sealant, Physical and Immersion Tests

SB22.1 Tensile strength and elongation

SB22.1.1 The tensile strength and elongation of gaskets and seals used in the construction of exhaust hood, fittings, and accessories for use with hoods shall not decrease by more than 50 percent of their original tensile strength and elongation after being subjected to the exposures described in SB22.2.2 and SB22.2.3. The part shall show no apparent deterioration, such as cracking, hardening, softening, melting, or damage after these exposures.

Added SB22.1.1 effective April 29, 1997

SB22.1.2 The average volume change of gaskets and seals used in the construction of exhaust hood, fittings, and accessories for use with exhaust hoods shall be in the range of minus 1 to plus 50 percent after being subjected to the exposures specified in SB22.3.1.

Added SB22.1.2 effective April 29, 1997

SB22.1.3 For tensile strength and ultimate elongation determination, nine specimens are to be prepared. The test procedures are to be as outlined in the section covering the tensile strength and ultimate elongation test in the Standard for Gaskets and Seals, UL 157.

Added SB22.1.3 effective April 29, 1997

SB22.2 Aging and immersion

SB22.2.1 If the size or shape of the gasket or seal is such that tensile strength and elongation specimens cannot be obtained from the part, the complete part, or a section from the part, the gasket or the seal is to be subjected to the aging and immersion exposures specified in SB22.2.2 and SB22.2.3.

Added SB22.2.1 effective April 29, 1997

SB22.2.2 Three specimens are to be subjected to air oven aging at 277 ±1.8°F (136 ±1°C) for seven days. The test procedures are to be as outlined in the section covering the accelerated air oven aging test in the Standard for Gaskets and Seals, UL 157.

Added SB22.2.2 effective April 29, 1997

SB22.2.3 Three specimens are to be immersed for 70 hours in lard and three specimens are to be immersed in corn oil at $277 \pm 1.8^\circ\text{F}$ ($136 \pm 1^\circ\text{C}$). The test procedures are to be as outline in the section covering the immersion test and the method for tensile strength and elongation tests in the Standard for Gaskets and Seals, UL 157.

Added SB22.2.3 effective April 29, 1997

SB22.3 Volume change

SB22.3.1 Three specimens from the gaskets or seals are to be immersed for 70 hours in lard and three specimens are to be immersed in corn oil at $277 \pm 1.8^\circ\text{F}$ ($136 \pm 1^\circ\text{C}$). The test procedures are to be as outlined in the section covering the immersion test, method for volume change in the Standard for Gaskets and Seals, UL 157.

Added SB22.3.1 effective April 29, 1997

SB23 Fire and Leakage Test of Fittings, Nonwelded Seams, Doors and Panels Used in Grease-Air Stream Enclosures

SB23.1 When a fitting is tested as specified in SB23.2 – SB23.4, there shall be no propagation of grease vapor or flame through or around the fitting.

Added SB23.1 effective April 29, 1997

SB23.2 Two representative samples of the fitting shall be installed in a 20 by 20 inch (508 by 508 mm), 0.064 inch (1.63 mm) thick stainless steel plate in accordance with the manufacturer's specifications. The plate and fittings shall then be evenly coated with grease on the fire exposed side (bottom) to obtain a loading of 0.3 pound per square foot (1.5 kg/m^2).

Added SB23.2 effective April 29, 1997

SB23.3 The plate containing the test samples is to be positioned horizontally (grease side down) 18 inches (457 mm) above a metal container holding three pints (1.4 L) of grease. The container is to measure approximately 13 inches (330 mm) in diameter by 8-1/2 inches (216 mm) deep and having an evaporating surface at the liquid level of approximately 130 square inches (839 cm^2). This container is to be placed on a heat source capable of heating the grease to 600°F (315°C). The preheated grease is then ignited.

Added SB23.3 effective April 29, 1997

SB23.4 The test is continued until all of the grease has burned and the container is dry.

Added SB23.4 effective April 29, 1997

MARKING

SB24 Fire Extinguishing System Unit Container

SB24.1 The fire extinguishing system unit container shall be provided with a permanent marking, including all required information as specified in the Standard for Dry Chemical Extinguishing Systems, NFPA 17-1990, or the Standard for Wet Chemical Extinguishing Systems, NFPA 17A-1990, and the applicable requirements for pre-engineered fire extinguishing systems from UL 1254, the Standard for Pre-Engineered Extinguishing System Units.

Added SB24.1 effective April 29, 1997

SB25 Product

SB25.1 A product designed for permanent connection to the electrical source of supply and intended for use near combustible surfaces shall be permanently marked with the minimum required clearance distances to adjacent combustible materials. If the product is intended for cord and plug connection to the electrical source or is not tested in a combustible alcove at a designated minimum clearance, the product shall be marked "Intended for Use in Noncombustible Surroundings Only." This marking shall be readily visible and shall have the minimum dimensions specified in SB25.6.

Added SB25.1 effective April 29, 1997

SB25.2 The product shall be permanently marked with:

- a) The location where each filter is to be installed.
- b) Any instructions needed to properly mount the filters.
- c) The maintenance frequency of the filters.
- d) If the product is provided with a removable cover to be used during the cooking process, the product shall be marked when and how it is to be used. If the product is provided with a cover to be used when the heater is not energized, the cover shall be permanently marked "Not for use when preheating, idling, or cooking."
- e) If battery backup is provided, the product shall be marked in the battery compartment with the battery type, size, rating and to replace the battery only with the same type.

This marking shall be readily visible and shall have the minimum dimensions specified in SB25.6.

Added SB25.2 effective April 29, 1997

SB25.3 A cooking appliance provided with an integral recirculating system shall be permanently marked with its kilowatt rating. This marking shall be readily visible and shall have the minimum dimensions specified in SB25.6.

Added SB25.3 effective April 29, 1997

SB25.4 A nonintegral recirculating system shall be permanently marked stating a reference to the types and quantities of cooking appliances to be used, their maximum kilowatt ratings, any restrictions in appliance installation below the hood, and the maximum volume, surface areas, or both of the cooking cavity, and maximum operating temperature for each cooking appliance covered.

Added SB25.4 effective April 29, 1997

SB25.5 The recirculating systems intended to be permanently attached to the building structure and which comply with SB18.4 shall be permanently marked with the following or the equivalent:

- a) "To Be Permanently Attached To The Building Structure,"
- b) "CAUTION: Keep Combustible Materials, Products, And Fixtures At Least___^a Inches From This Device," and
- c) "Ceiling Height Shall Be No Less Than___^a Inches."

^aThese distances are values determined in the test in accordance with SB18.4. The marking shall be readily visible and shall have the minimum dimensions specified in SB25.6.

Added SB25.5 effective April 29, 1997

SB25.6 With respect to SB25.1 – SB25.5, "readily visible" means visible from a point 5 feet (1.5 m) above the floor and between 1 and 4 feet (0.3 and 1.2 m) away from the front surface of the unit when the unit is placed in the intended use location. The marking shall be in letters not less than 1/8 inch (3.2 mm) in height and shall be of a permanent type and in a color that contrasts with that of the background.

Added SB25.6 effective April 29, 1997

INSTRUCTIONS

SB26 Use and Maintenance

SB26.1 Manufacturer's instructions shall be provided with each product indicating that its use and maintenance is to be in accordance with the Standard for Ventilation Control and Fire Protection of Commercial Cooking Operations, NFPA 96-1994.

Added SB26.1 effective April 29, 1997

SB27 Fire Extinguishing System Unit Maintenance

SB27.1 The instructions provided with the product shall include information regarding maintenance of the fire extinguishing system unit as outlined in the Standard for Dry Chemical Extinguishing Systems, NFPA 17-1990 or the Standard for Wet Chemical Extinguishing Systems, NFPA 17A-1990, and applicable requirements covering pre-engineered fire extinguishing systems.

Added SB27.1 effective April 29, 1997

SB28 Manual Actuation Of Fire Extinguishing System Unit

SB28.1 The instructions provided with the product shall include information for providing the manual actuation of the fire extinguishing system unit. The manual actuation device shall be readily accessible, in a path of exit or egress and shall be clearly identified. Installation of the manual actuation device shall comply with the applicable installation standards and codes.

Added SB28.1 effective April 29, 1997

SB29 Installation Instructions

SB29.1 The instructions shall indicate that the installation is to be in accordance with the Standard for Ventilation Control and Fire Protection of Commercial Cooking Operations, NFPA 96-1994.

Added SB29.1 effective April 29, 1997

SB30 Permanently Attached Hoods

SB30.1 The instructions for permanently attached hoods shall:

- a) Indicate that they are to be permanently attached to the building structure, and
- b) Specify that the minimum ceiling height in the area where these hoods are installed is not to be less than that determined suitable in SB18.4.

Added SB30.1 effective April 29, 1997