

# INTERNATIONAL STANDARD

# IEC 60335-2-96

2002

AMENDMENT 1  
2003-08

---

---

Amendment 1

**Household and similar electrical appliances –  
Safety –**

**Part 2-96:  
Particular requirements for flexible sheet  
heating elements for room heating**

*Amendement 1*

*Appareils électrodomestiques et analogues –  
Sécurité –*

*Partie 2-96:  
Règles particulières pour les films souples  
chauffants pour le chauffage des locaux*

© IEC 2003 Droits de reproduction réservés — Copyright - all rights reserved

International Electrotechnical Commission, 3, rue de Varembé, PO Box 131, CH-1211 Geneva 20, Switzerland  
Telephone: +41 22 919 02 11 Telefax: +41 22 919 03 00 E-mail: [inmail@iec.ch](mailto:inmail@iec.ch) Web: [www.iec.ch](http://www.iec.ch)



Commission Electrotechnique Internationale  
International Electrotechnical Commission  
Международная Электротехническая Комиссия

PRICE CODE

**K**

*For price, see current catalogue*

## FOREWORD

This amendment has been prepared by technical committee 61: Safety of household and similar electrical appliances.

The text of this amendment is based on the following documents:

FDIS	Report on voting
61/2429/FDIS	61/2464 /RVD

Full information on the voting for the approval of this amendment can be found in the report on voting indicated in the above table.

The committee has decided that the contents of the base publication and its amendments will remain unchanged until 2005. At this date, the publication will be

- reconfirmed;
- withdrawn;
- replaced by a revised edition, or
- amended.

---

## 2 Normative references

*Addition:*

ISO 3864, *Safety colours and safety signs*

## 3 Definitions

*Add the following:*

### 3.2.7 Replacement:

#### **supply leads**

set of wires intended for connecting the appliance to fixed wiring

## 5 General conditions for the tests

### 5.2 Add the following:

*The test of 22.105 is carried out on the same sample as that used for the test of 13.2.*

*Two samples of the additional layer of material, of sufficient size to cover the **heating unit**, are required if the test of 21.104 is carried out.*

Add the following:

**5.3 Addition:**

The test of 22.105 is carried out after the test of 13.2.

**5.101 Heating units** intended to be installed in walls above a height of 2,3 m are subjected to the tests for installation in ceilings.

**7 Marking and instructions**

**7.1 Delete note 101.**

Add the following:

**7.6 Addition:**

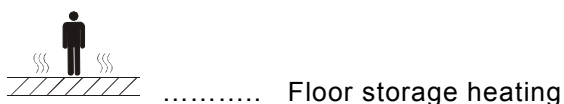
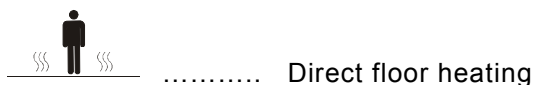
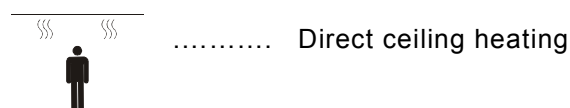

These symbols are information signs and, except for the colours, the rules of ISO 3864 apply.

**7.12.1**

Replace item a) by the following:

a) an explanation of the marking and symbols, if necessary;

Replace the text of the third dash of the second paragraph of item b) by:

- a description of the intended orientation and a statement that the heating unit is to be installed in this way (for heating units having non-symmetric construction).

Replace the beginning of the third sentence of the first dash of item c) and the text of the first bullet by the following:

This statement is not required for **class III heating units** and for applications in

- timber floors provided that the instructions for installation state that there is to be an air gap between the heating unit and the floor;

Add the following:

- l) in applications in timber floors, a statement indicating that heating units having basic insulation only shall be covered by additional electrical insulation or supplied through an isolating transformer. This statement is not required if the heating units are class II.

#### 7.12.101 b)

Replace the first sentence by the following:

When the heating units have been positioned, they must be covered with an additional layer of material for mechanical protection.

Replace the text of the first dash by the following:

- screened insulated heating wires are covered with a sheath complying with 21.103;

#### 7.14 Addition:

If symbols are used relating to the intended installation or heating mode, the superimposed rectangle shall have a height of at least 15 mm.

## 11 Heating

11.2.103 Replace the first paragraph by the following:

**Heating units** intended to be installed in a timber floor are placed in a test framework, as shown in Figure 103. **Heating units** intended to be installed on top of a timber floor are placed in a test framework as shown in Figure 107. An area of at least 4 m<sup>2</sup> having a shorter dimension not less than 2 m is covered by at least three **heating units**, the unit under test being placed in the middle. Thermal insulation having a thermal resistance of approximately 5 m<sup>2</sup> K/W is located below the **heating units**. The **heating units** are installed in accordance with the instructions for installation, attention being paid to where they can be located over parts of the timber structure such as cross-members. The upper side of the framework is covered with the most unfavourable floor with regard to the total thermal resistance in accordance with the instructions for installation, an air gap being maintained as shown in the figures, if specified in the instructions.

In the first sentence of the third paragraph, replace “Figure 103” by “Figures 103 and 107”.

Replace the fourth and fifth paragraphs by the following:

**Heating units** intended to be installed in a floor of concrete or similar material are placed as shown in Figure 104. **Heating units** intended to be installed above a floor of concrete or similar material are placed as shown in Figure 108. **Heating units** are installed in accordance with the instructions for installation, any specified additional electrical insulation being placed over them. An area of at least 4 m<sup>2</sup>, having a shorter dimension not less than 2 m, is covered by at least three **heating units**, the unit under test being placed in the middle. Thermal insulation having a thermal resistance of approximately 2,5 m<sup>2</sup> K/W is located underneath the **heating units**. For **heating units** intended to be installed in concrete or similar material, the thermal insulation is supported by a dull black painted plywood board approximately 20 mm thick.

The **heating units** are covered with the additional layer, if specified in the instructions. They are then covered with a layer of concrete approximately 40 mm thick or the thickness stated in the instructions, whichever is greater. Instead of pouring concrete, the concrete layer may consist of concrete slabs 40 mm thick and having dimensions at least 500 mm x 500 mm, the gaps between the slabs being filled with dry sand. If the **heating unit** is intended for a **storage heating application**, the thickness of the concrete is increased to 80 mm. The concrete layer is not included for **heating units** intended to be installed on top of a concrete floor. A grid is included in the test arrangement if specified. The floor is covered with the most unfavourable flooring material listed in the instructions for installation. There is a free space of at least 1,5 m above the floor.

In the first sentence of the sixth paragraph, replace “Figure 104” by “Figures 104 and 108”.

## 16 Leakage current and electric strength

**16.3** In the third line of the fourth paragraph, replace “this insulation” by “this additional insulation”.

Add the following:

For **heating units** with **basic insulation** only, other than those supplied through an isolating transformer, that are provided with additional electrical insulation for application in timber floors, this additional insulation shall withstand the test voltage specified for **supplementary insulation**.

## 19 Abnormal operation

**19.1** Delete the addition.

**19.101** Delete this subclause.

## 21 Mechanical strength

Add the following before the last paragraph of the addition:

The additional layer of material covering **heating units** in floors of concrete or similar material, or under tiles, is subjected to the test of 21.104.

**21.103** In the first paragraph, add the following after the first sentence:

If screened insulated wires are covered by a sheath, the sheath is removed.

Add the following:

If screened insulated wires are covered by a sheath, the test is repeated with the sheath in place.

There shall be no penetration of the sheath.

NOTE The electric strength test is not carried out.

Add the following subclause:

**21.104** A sample of the additional layer of material is placed on a horizontal steel plate having a smooth surface and is scratched by means of a hardened steel pin, the end of which has the form of a cone with an angle of 40°. Its tip is rounded with a radius of 0,25 mm ± 0,02 mm. The pin is loaded so that the force exerted along its axis is 10 N ± 0,5 N for applications in concrete and similar floors and 5 N ± 0,5 N for other applications. The pin is held at an angle of 80° to 85° to the horizontal and scratches are made by drawing the pin along the surface at a speed of approximately 20 mm/s.

Three scratches are made at least 50 mm apart. Scratches shall be at least 10 mm from one of the edges. The length of the scratches is approximately equal to the width of the **heating unit**.

Similar scratches are made on the second sample, but at right angles to the direction of the scratches on the first sample.

There shall be no penetration of the material.

## 22 Construction

Add the following subclause:

**22.105 Heating units of class II construction** intended to be installed under floors in damp locations shall not subject the user to excessive capacitive currents.

NOTE **Heating units** having **basic insulation** only, but covered with additional electrical insulation, are considered to be **class II construction**.

Compliance is checked by the following test. However, the test is not carried out if the instructions for installation specify that an air gap is required between the **heating unit** and the floor.

The grid is connected to earth and to metal foil having an area approximately 200 mm x 100 mm through the measurement instrument shown in Figure 109. The surface of the floor directly above a **heating unit** is covered with 0,25 l of water containing approximately 1 % NaCl and left for 2 h. The metal foil is placed on the wet surface and the **heating units** are supplied at 1,06 times **rated voltage**.

The capacitive current shall not exceed 0,25 mA.

## 24 Components

**24.102** Replace the requirement by the following:

Controls and other components necessary for the **heating unit** to comply with this standard shall be supplied with the **flexible sheet heating element** or sufficiently specified in the instructions for installation so they can be obtained separately.

## 26 Terminals for external conductors

*Add the following:*

### 26.5 *Modification:*

This requirement applies to all terminals to which connections are made during installation.

### 26.11 *Addition:*

This requirement also applies to **heating units** fitted with **supply leads**.

## 27 Provision for earthing

*Replace the text by the following:*

This clause of Part 1 is applicable except as follows.

### 27.1 *Addition:*

Components provided for the reduction of capacitive currents, and which are earthed, are not considered to provide provision for earthing.

## 30 Resistance to heat and fire

### 30.2.1 *Delete the modification.*

### 30.2.3.1 *Replace the text by the following:*

*This subclause is not applicable to **flexible sheet heating elements**.*

### 30.2.3.2 *Delete the modification.*

## Figure 104

*Replace the title by the following:*

### **Arrangement for testing heating units below concrete**

*Replace item 5 of the key by the following:*

5 Additional layer (if specified)

Add the following figures:

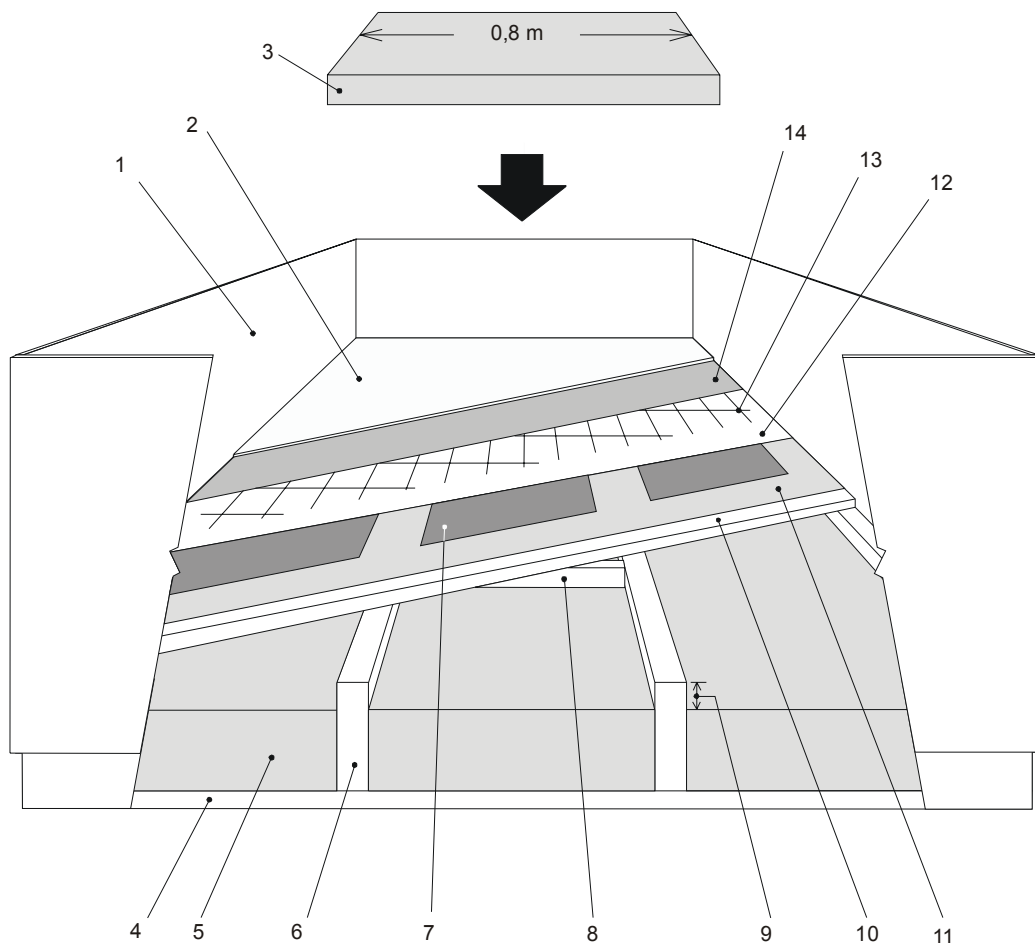

IEC 1994/03

**Key**

- 1 Wooden board
- 2 Floor
- 3 Piece of insulation
- 4 Support for thermal insulation
- 5 Thermal insulation
- 6 50 mm x 200 mm timber frame
- 7 **Heating unit**
- 8 Cross member
- 9 Air gap (if specified)
- 10 Plywood
- 11 Additional material (if specified)
- 12 Additional electrical insulation (if specified)
- 13 Grid
- 14 Additional layer (if specified)

**Figure 107 – Arrangement for testing heating units above timber floors**



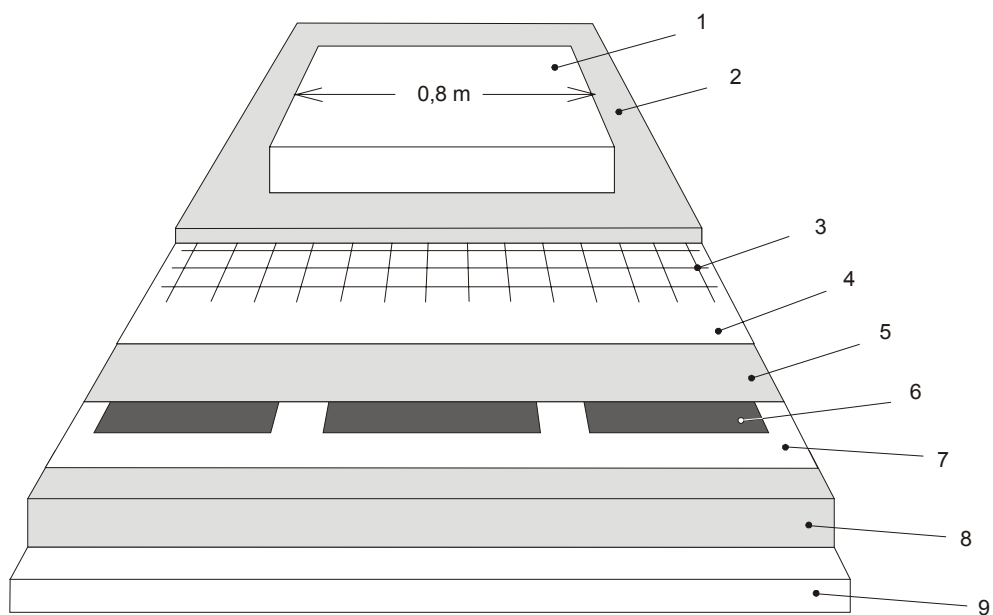

IEC 1995/03

**Key**

- 1 Piece of insulation
- 2 Floor
- 3 Grid
- 4 Additional layer (if specified)
- 5 Additional electrical insulation (if specified)
- 6 **Heating unit**
- 7 Additional layer (if specified)
- 8 Thermal insulation
- 9 Concrete base

**Figure 108 – Arrangement for testing heating units above concrete floors**

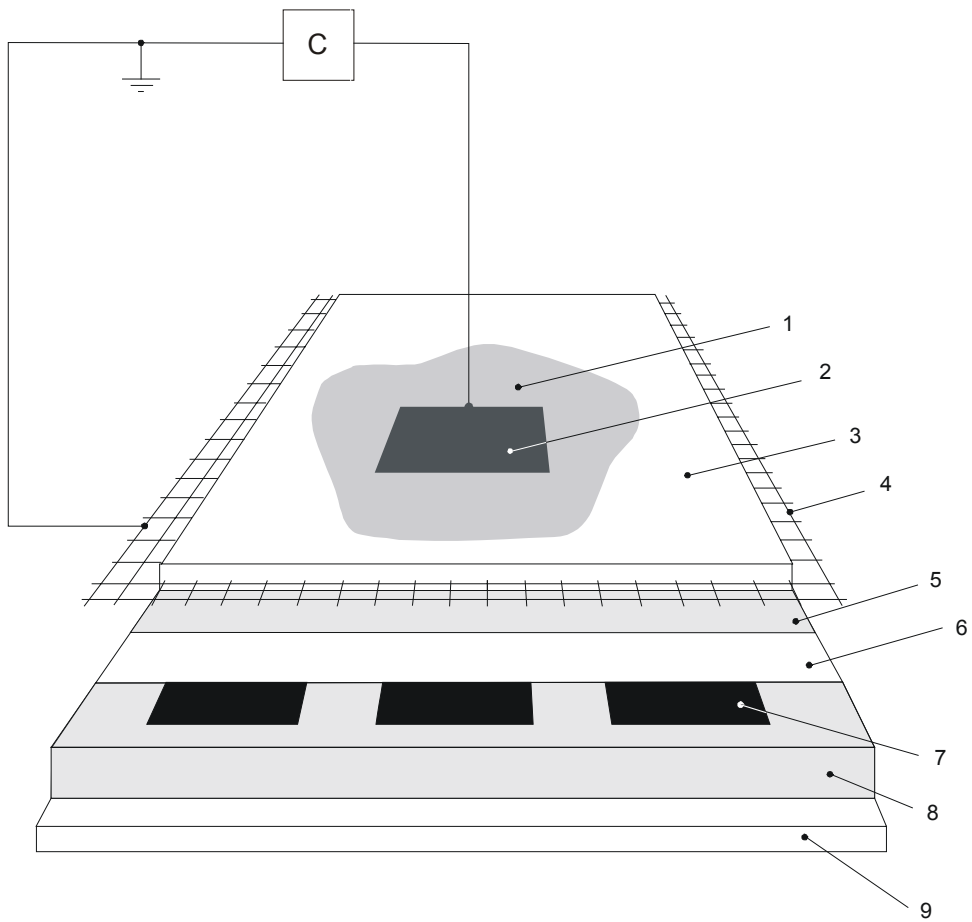

IEC 1996/03

**Key**

- C Circuit of Figure 4 of IEC 60990
- 1 Saline solution
- 2 Metal foil
- 3 Floor covering
- 4 Grid
- 5 Additional layer (if specified)
- 6 Additional electrical insulation (if specified)
- 7 **Heating unit**
- 8 Thermal insulation
- 9 Plywood base

**Figure 109 – Arrangement for measuring capacitive currents**





ISBN 2-8318-7137-9



9 782831 871370

---

**ICS 13.120; 97.100.10**

---

Typeset and printed by the IEC Central Office  
GENEVA, SWITZERLAND