

INTERNATIONAL
STANDARD

IEC
60335-2-21

Fifth edition
2002-07

**Household and similar electrical appliances –
Safety –**

**Part 2-21:
Particular requirements for storage water heaters**

*Appareils électrodomestiques et analogues –
Sécurité –*

*Partie 2-21:
Règles particulières pour les chauffe-eau à accumulation*



Reference number
IEC 60335-2-21:2002(E)

Publication numbering

As from 1 January 1997 all IEC publications are issued with a designation in the 60000 series. For example, IEC 34-1 is now referred to as IEC 60034-1.

Consolidated editions

The IEC is now publishing consolidated versions of its publications. For example, edition numbers 1.0, 1.1 and 1.2 refer, respectively, to the base publication, the base publication incorporating amendment 1 and the base publication incorporating amendments 1 and 2.

Further information on IEC publications

The technical content of IEC publications is kept under constant review by the IEC, thus ensuring that the content reflects current technology. Information relating to this publication, including its validity, is available in the IEC Catalogue of publications (see below) in addition to new editions, amendments and corrigenda. Information on the subjects under consideration and work in progress undertaken by the technical committee which has prepared this publication, as well as the list of publications issued, is also available from the following:

- **IEC Web Site** (www.iec.ch)

- **Catalogue of IEC publications**

The on-line catalogue on the IEC web site (www.iec.ch/catlg-e.htm) enables you to search by a variety of criteria including text searches, technical committees and date of publication. On-line information is also available on recently issued publications, withdrawn and replaced publications, as well as corrigenda.

- **IEC Just Published**

This summary of recently issued publications (www.iec.ch/JP.htm) is also available by email. Please contact the Customer Service Centre (see below) for further information.

- **Customer Service Centre**

If you have any questions regarding this publication or need further assistance, please contact the Customer Service Centre:

Email: custserv@iec.ch
Tel: +41 22 919 02 11
Fax: +41 22 919 03 00

INTERNATIONAL STANDARD

IEC 60335-2-21

Fifth edition
2002-07

Household and similar electrical appliances – Safety –

Part 2-21: Particular requirements for storage water heaters

*Appareils électrodomestiques et analogues –
Sécurité –*

*Partie 2-21:
Règles particulières pour les chauffe-eau à accumulation*

© IEC 2002 — Copyright - all rights reserved

No part of this publication may be reproduced or utilized in any form or by any means, electronic or mechanical, including photocopying and microfilm, without permission in writing from the publisher.

International Electrotechnical Commission, 3, rue de Varembé, PO Box 131, CH-1211 Geneva 20, Switzerland
Telephone: +41 22 919 02 11 Telefax: +41 22 919 03 00 E-mail: inmail@iec.ch Web: www.iec.ch



Commission Electrotechnique Internationale
International Electrotechnical Commission
Международная Электротехническая Комиссия

PRICE CODE

L

For price, see current catalogue

CONTENTS

FOREWORD	3
INTRODUCTION	6
1 Scope	7
2 Normative references.....	7
3 Definitions	7
4 General requirement.....	9
5 General conditions for the tests	9
6 Classification	9
7 Marking and instructions	9
8 Protection against access to live parts	10
9 Starting of motor-operated appliances	10
10 Power input and current.....	10
11 Heating.....	10
12 Void	11
13 Leakage current and electric strength at operating temperature	11
14 Transient overvoltages.....	11
15 Moisture resistance.....	11
16 Leakage current and electric strength	11
17 Overload protection of transformers and associated circuits.....	11
18 Endurance	11
19 Abnormal operation.....	11
20 Stability and mechanical hazards.....	12
21 Mechanical strength.....	12
22 Construction	12
23 Internal wiring	15
24 Components	15
25 Supply connection and external flexible cords.....	16
26 Terminals for external conductors	16
27 Provision for earthing.....	16
28 Screws and connections	16
29 Clearances, creepage distances and solid insulation	16
30 Resistance to heat and fire	16
31 Resistance to rusting	16
32 Radiation, toxicity and similar hazards	17
 Annexes.....	 20
 Bibliography.....	 21
 Figure 101 – Examples of types of storage water heaters.....	 18
Figure 102 – Examples of positions of the thermocouples	19

INTERNATIONAL ELECTROTECHNICAL COMMISSION

**HOUSEHOLD AND SIMILAR ELECTRICAL APPLIANCES –
SAFETY –****Part 2-21: Particular requirements for storage water heaters**

FOREWORD

- 1) The IEC (International Electrotechnical Commission) is a worldwide organization for standardization comprising all national electrotechnical committees (IEC National Committees). The object of the IEC is to promote international co-operation on all questions concerning standardization in the electrical and electronic fields. To this end and in addition to other activities, the IEC publishes International Standards. Their preparation is entrusted to technical committees; any IEC National Committee interested in the subject dealt with may participate in this preparatory work. International, governmental and non-governmental organizations liaising with the IEC also participate in this preparation. The IEC collaborates closely with the International Organization for Standardization (ISO) in accordance with conditions determined by agreement between the two organizations.
- 2) The formal decisions or agreements of the IEC on technical matters express, as nearly as possible, an international consensus of opinion on the relevant subjects since each technical committee has representation from all interested National Committees.
- 3) The documents produced have the form of recommendations for international use and are published in the form of standards, technical specifications, technical reports or guides and they are accepted by the National Committees in that sense.
- 4) In order to promote international unification, IEC National Committees undertake to apply IEC International Standards transparently to the maximum extent possible in their national and regional standards. Any divergence between the IEC Standard and the corresponding national or regional standard shall be clearly indicated in the latter.
- 5) The IEC provides no marking procedure to indicate its approval and cannot be rendered responsible for any equipment declared to be in conformity with one of its standards.
- 6) Attention is drawn to the possibility that some of the elements of this International Standard may be the subject of patent rights. The IEC shall not be held responsible for identifying any or all such patent rights.

This part of International Standard IEC 60335 has been prepared by IEC technical committee 61: Safety of household and similar electrical appliances.

This fifth edition cancels and replaces the fourth edition published in 1997 and its amendment 1 (1999). It constitutes a technical revision.

The text of this part of IEC 60335 is based on the following documents:

FDIS	Report on voting
61/2135/FDIS	61/2160/RVD

Full information on the voting for the approval of this standard can be found in the report on voting indicated in the above table.

This part 2 is to be used in conjunction with the latest edition of IEC 60335-1 and its amendments. It was established on the basis of the fourth edition (2001) of that standard.

NOTE 1 When "Part 1" is mentioned in this standard, it refers to IEC 60335-1.

This part 2 supplements or modifies the corresponding clauses in IEC 60335-1, so as to convert that publication into the IEC standard: Safety requirements for electric storage water heaters.

When a particular subclause of Part 1 is not mentioned in this part 2, that subclause applies as far as is reasonable. When this standard states "addition", "modification", or "replacement", the relevant text in Part 1 is to be adapted accordingly.

NOTE 2 The following numbering system is used:

- subclauses, tables and figures that are numbered starting from 101 are additional to those in Part 1;
- unless notes are in a new subclause or involve notes in Part 1, they are numbered starting from 101, including those in a replaced clause or subclause;
- additional annexes are lettered AA, BB, etc.

NOTE 3 The following print types are used:

- requirements: in roman type;
- *test specifications: in italic type;*
- notes: in small roman type.

Words in **bold** in the text are defined in Clause 3. When a definition concerns an adjective, the adjective and the associated noun are also in bold.

The committee has decided that the contents of this publication will remain unchanged until 2004. At this date, the publication will be

- reconfirmed;
- withdrawn;
- replaced by a revised edition, or
- amended.

The following differences exist in the countries indicated below.

- 6.1: Class 0I appliances are allowed (Japan).
- 6.2: IPX0 water heaters are allowed (France, Portugal, United Kingdom and USA).
- 7.1: Additional markings are required (Australia, New Zealand and South Africa).
- 7.1: The rated pressure is to be marked in pounds per square inch (USA).
- 7.1: Open outlet water heaters are not required to be marked with rated pressure (USA).
- 7.12.1: Additional instructions are required (South Africa).
- 11.7: The test is different (USA).
- 19.1: Water heaters that have all four features and are not liable to be emptied in normal use are not subjected to the test of 19.101 (South Africa).
- 19.1: Appliances incorporating sheathed heating elements are not required to have an outer enclosure of metal but their rated power input is limited to 12 kW (USA).
- 19.101: The test is different (USA).
- 22.101: Pressure reducing valves have to be designed for an inlet pressure of 2 MPa (South Africa).
- 22.101: The minimum rated pressure is 1,0 MPa (Denmark, Finland, Norway and Sweden).
- 22.102: The minimum pressure is 2,1 MPa. The test is not carried out on water heaters having a capacity less than 2 l or on appliances having containers open to the atmosphere (USA).
- 22.103: Closed water heaters have to incorporate a pressure-relief device (Norway).
- 22.103: Closed water heaters have to incorporate a pressure-relief device sensitive to both pressure and temperature that operates before the water temperature reaches 99 °C (Australia and New Zealand).
- 22.103: Closed water heaters having a capacity exceeding 50 l or a rated power input exceeding 2 kW have to incorporate a pressure-relief device sensitive to both pressure and temperature that operates before the water temperature reaches 99 °C (South Africa).
- 22.103: Closed water heaters have to incorporate a temperature relief valve or a combined temperature and pressure-relief valve that operates before the water temperature reaches 100 °C (United Kingdom).
- 22.106: All water heaters have to incorporate a thermal cut-out (India).
- 22.106: The thermal cut-out of single-phase closed water heaters need only provide single-pole disconnection (Japan).

- 22.106: For all closed water heaters, the thermal cut-out is to provide all-pole disconnection (France, Netherlands, Norway and Switzerland).
- 22.109: A tool is not required for draining the appliance (Canada and USA).
- 22.110: Additional requirements apply to plastic or resin-based containers (South Africa).
- 22.112: The temperature limit is 95 °C (South Africa).
- 22.112: The temperature limit is 85 °C (USA).
- 24.101: Thermal cut-outs are required to have a trip-free switching mechanism (USA).
- 24.102: The maximum water temperature is 90 °C (Australia and New Zealand).
- 24.102: The maximum water temperature is 99 °C (Japan, Norway, Portugal, United Kingdom and USA)
- 24.102: The temperature limit of 130 °C is only allowed for closed water heaters having a rated pressure of at least 0,4 MPa (South Africa).

INTRODUCTION

It has been assumed in the drafting of this International Standard that the execution of its provisions is entrusted to appropriately qualified and experienced persons.

This standard recognizes the internationally accepted level of protection against hazards such as electrical, mechanical, thermal, fire and radiation of appliances when operated as in normal use taking into account the manufacturer's instructions. It also covers abnormal situations that can be expected in practice.

This standard takes into account the requirements of IEC 60364 as far as possible so that there is compatibility with the wiring rules when the appliance is connected to the supply mains. However, national wiring rules may differ.

If an appliance within the scope of this standard also incorporates functions that are covered by another part 2 of IEC 60335, the relevant part 2 is applied to each function separately, as far as is reasonable. If applicable, the influence of one function on the other is taken into account.

This standard is a product family standard dealing with the safety of appliances and takes precedence over horizontal and generic standards covering the same subject.

An appliance that complies with the text of this standard will not necessarily be considered to comply with the safety principles of the standard if, when examined and tested, it is found to have other features that impair the level of safety covered by these requirements.

An appliance employing materials or having forms of construction differing from those detailed in the requirements of this standard may be examined and tested according to the intent of the requirements and, if found to be substantially equivalent, may be considered to comply with the standard.

HOUSEHOLD AND SIMILAR ELECTRICAL APPLIANCES – SAFETY –

Part 2-21: Particular requirements for storage water heaters

1 Scope

This clause of Part 1 is replaced by the following.

This International Standard deals with the safety of electric **storage water heaters** for household and similar purposes and intended for heating water below boiling temperature, their **rated voltage** being not more than 250 V for single-phase appliances and 480 V for other appliances.

Appliances not intended for normal household use but which nevertheless may be a source of danger to the public, such as appliances intended to be used by laymen in shops, in light industry and on farms, are within the scope of this standard.

As far as is practicable, this standard deals with the common hazards presented by appliances that are encountered by all persons in and around the home. However, in general, it does not take into account

- the use of appliances by young children or infirm persons without supervision;
- playing with the appliance by young children.

NOTE 101 Attention is drawn to the fact that

- for appliances intended to be used at high altitudes, additional requirements may be necessary;
- for appliances intended to be used in vehicles or on board ships or aircraft, additional requirements may be necessary;
- in many countries additional requirements are specified by the national health authorities, the national authorities responsible for the protection of labour and similar authorities;
- in many countries regulations exist for the installation of equipment connected to the water mains.

NOTE 102 This standard does not apply to

- appliances for boiling water (IEC 60335-2-15);
- instantaneous water heaters (IEC 60335-2-35);
- commercial dispensing appliances and vending machines (IEC 60335-2-75);
- appliances intended exclusively for industrial purposes;
- appliances intended to be used in locations where special conditions prevail, such as the presence of a corrosive or explosive atmosphere (dust, vapour or gas).

2 Normative references

This clause of Part 1 is applicable.

3 Definitions

This clause of Part 1 is applicable except as follows.

3.1.9 *Replacement:*

normal operation

operation of the appliance after installation in accordance with the instructions and filled with cold water

3.101

storage water heater

stationary appliance for heating and storing water in a container and incorporating devices to control the water temperature

3.102

closed water heater

unvented **storage water heater** intended to operate at the pressure of the water system, the flow of water being controlled by one or more valves in the outlet system

NOTE 1 A **closed water heater** is shown in Figure 101a.

NOTE 2 The operating pressure may be the output pressure of a reducing or boosting device.

3.103

cistern-fed water heater

storage water heater that is vented to atmosphere and intended to be supplied by water under gravity from a separate cistern, the flow of water being controlled by one or more valves in the outlet system

NOTE 1 A **cistern-fed water heater** is shown in Figure 101b.

NOTE 2 The water heater may be installed so that the expanded water returns to the cistern.

NOTE 3 In a **cistern-fed water heater**, the pressure in the container results from the column of water in the cistern.

3.104

cistern-type water heater

storage water heater having a container supplied by water under gravity from a cistern incorporated in the appliance. The expanded water can return to the cistern, the flow of water being controlled by one or more valves in the outlet system

NOTE 1 A **cistern-type water heater** is shown in Figure 101c.

NOTE 2 In a **cistern-type water heater**, the surface of the water is always at atmospheric pressure.

3.105

open-outlet water heater

storage water heater in which the flow of water is only controlled by a valve in the inlet pipe and in which the expanded or displaced water flows through the outlet

NOTE 1 An **open-outlet water heater** is shown in Figure 101d.

NOTE 2 In an **open-outlet water heater**, the static pressure at the outlet is always at atmospheric pressure.

3.106

low-pressure water heater

storage water heater that is vented to atmosphere and intended to be connected to the water mains through a pressure reducing valve, the flow of water being controlled by one or more valves in the outlet system

NOTE A **low-pressure water heater** is shown in Figure 101e.

3.107

rated pressure

water pressure assigned to the appliance by the manufacturer

4 General requirement

This clause of Part 1 is applicable.

5 General conditions for the tests

This clause of Part 1 is applicable except as follows.

5.2 Addition:

NOTE 101 Additional appliances may be required if damage occurs during the tests of 19.2 or 19.3.

5.3 Addition:

When the tests are carried out on a single appliance, the tests of 22.102, 22.103, 22.112 and 24.102 are carried out before the tests of Clause 19.

6 Classification

This clause of Part 1 is applicable except as follows.

6.1 Modification:

Water heaters shall be **class I**, **class II** or **class III**.

6.2 Addition:

Water heaters for installation outdoors shall be at least IPX4. Other water heaters shall be at least IPX1.

7 Marking and instructions

This clause of Part 1 is applicable except as follows.

7.1 Addition:

Appliances, other than **cistern-type water heaters**, shall be marked with the **rated pressure** in pascals.

Appliances shall be marked with the rated capacity in litres.

Closed water heaters shall be marked with a statement that a pressure-relief device is to be fitted in the installation, unless it is incorporated in the appliance.

Closed water heaters having a **rated pressure** less than 0,6 MPa and **low-pressure water heaters** shall be marked with a statement that a pressure reducing valve is to be fitted in the installation.

Open-outlet water heaters shall be marked, close to the outlet connection or on a tag attached to the appliance, with the substance of the following:

WARNING: This outlet acts as a vent and must only be connected to a fitting recommended by the manufacturer. It must not be connected to a tap.

7.12 Addition:

The instructions for **closed water heaters** shall state the substance of the following:

- the water may drip from the discharge pipe of the pressure-relief device and that this pipe must be left open to the atmosphere;
- the pressure-relief device is to be operated regularly to remove lime deposits and to verify that it is not blocked;
- how the water heater can be drained.

7.12.1 *Addition:*

The installation instructions shall state the substance of the following:

- the type or characteristics of the pressure-relief device and how to connect it, unless it is incorporated in the appliance;
- a discharge pipe connected to the pressure-relief device is to be installed in a continuously downward direction and in a frost-free environment;
- the type or characteristics of a pressure reducing valve and the installation details (for appliances having a **rated pressure** less than 0,6 MPa).

The instructions for **closed water heaters** incorporating a heat exchanger shall give details on the installation of control devices and the temperature settings that are necessary to prevent operation of the **thermal cut-out** caused by the heat from the exchanger.

The instructions for **cistern-fed water heaters** and **low-pressure water heaters** shall contain the substance of the following:

WARNING: Do not connect any pressure-relief device to the vent pipe of this water heater.

7.101 The water inlet and the water outlet shall be identified. This identification shall not be on **detachable parts**. If colours are used, blue shall be used for the inlet and red for the outlet.

NOTE Identification may be by means of arrows showing the direction of the water flow.

Compliance is checked by inspection.

8 Protection against access to live parts

This clause of Part 1 is applicable.

9 Starting of motor-operated appliances

This clause of Part 1 is not applicable.

10 Power input and current

This clause of Part 1 is applicable.

11 Heating

This clause of Part 1 is applicable except as follows.

11.7 *Replacement:*

*The appliance is operated until steady conditions are established or until the **thermostat** interrupts the current for the first time after 16 h, whichever is shorter.*

12 Void

13 Leakage current and electric strength at operating temperature

This clause of Part 1 is applicable.

14 Transient overvoltages

This clause of Part 1 is applicable.

15 Moisture resistance

This clause of Part 1 is applicable except as follows.

15.2 Addition:

The test is only applicable to cistern-type water heaters.

15.3 Addition:

NOTE 101 If the appliance is too large for the humidity cabinet, the test may be carried out on those parts that contain electrical components.

16 Leakage current and electric strength

This clause of Part 1 is applicable.

17 Overload protection of transformers and associated circuits

This clause of Part 1 is applicable.

18 Endurance

This clause of Part 1 is not applicable.

19 Abnormal operation

This clause of Part 1 is applicable except as follows.

19.1 Modification:

Instead of the tests specified for appliances incorporating heating elements, the following applies.

For closed water heaters, low-pressure water heaters and open-outlet water heaters, compliance is checked by the tests of 19.2, 19.3 and 19.4 if applicable. However, 19.101 applies instead for appliances not liable to be emptied in normal use and having all four of the following features:

– *an outer enclosure of metal;*

NOTE 101 Non-metallic covers may be used for the supply terminals and controls.

– *non-combustible thermal insulation;*

NOTE 102 Insulation withstanding the needle flame test of Annex E is considered to be non-combustible.

- *a capacity exceeding 30 l;*
- *a rated power input not exceeding 6 kW.*

NOTE 103 Appliances are not considered liable to be emptied in normal use if emptying through the inlet is prevented by a check valve, a pipe interrupter or an air gap. These devices may be fitted in the inlet pipe in accordance with the instructions. Emptying through openings provided for servicing purposes only is not considered to be normal use.

NOTE 104 **Cistern-fed water heaters** and **cistern-type water heaters** are not subjected to the tests.

19.2 Addition:

The appliance is operated empty, any thermal control that operates during the test of Clause 11 being short-circuited.

NOTE 101 If the appliance is provided with more than one thermal control, these are short-circuited in turn.

19.3 Addition:

NOTE 101 If the water heater has been damaged during the previous test, a new appliance is used.

19.4 Replacement:

*For **open-outlet water heaters**, the test of 19.2 is repeated but with the container filled with water to a level at least 10 mm above the highest point of the heating element. The appliance is operated at 1,15 times **rated power input** under **normal operation**.*

NOTE 101 If the water heater has been damaged during previous tests, a new appliance is used.

19.13 Addition:

There shall be no leakage from the container during the tests.

19.101 *The appliance is tested for 24 h under the conditions specified in Clause 11 but with the container empty.*

20 Stability and mechanical hazards

This clause of Part 1 is applicable.

21 Mechanical strength

This clause of Part 1 is applicable.

22 Construction

This clause of Part 1 is applicable except as follows.

22.6 Addition:

The enclosure shall have a drain hole positioned so that the water can drain without impairing electrical insulation, unless condensed water cannot accumulate within the enclosure in normal use. The hole shall be at least 5 mm in diameter or 20 mm² in area with a width of at least 3 mm.

Compliance is checked by inspection and measurement.

22.20 Addition:

Thermal insulation shall not be used for **basic insulation** of internal wiring.

22.101 The **rated pressure** of **closed water heaters** intended for direct connection to the water main shall be at least 0,6 MPa.

The **rated pressure** of **closed water heaters** and **low-pressure water heaters**, intended to be supplied by a pressure reducing valve that is not incorporated in the appliance, shall be at least 0,1 MPa.

The **rated pressure** of **cistern-fed water heaters** shall not exceed 0,2 MPa.

NOTE The **rated pressure** of **open-outlet water heaters** is 0 Pa.

Compliance is checked by inspection.

22.102 Appliances shall withstand the water pressure occurring in normal use.

Compliance is checked by subjecting the appliance to a water pressure of

- *twice the **rated pressure**, for **closed water heaters**. If the water heater is supplied through a pressure reducing valve, the container is subjected to twice the working pressure instead;*

NOTE 1 The pressure reducing valve may be incorporated in the water-inlet pipe.

NOTE 2 The working pressure is the maximum pressure in the container measured during the test of Clause 11.

- *1,5 times **rated pressure**, for **cistern-fed water heaters** and **low-pressure water heaters**;*
- *0,15 MPa, for **open-outlet water heaters**;*
- *0,03 MPa, for **cistern-type water heaters**.*

Pressure-relief devices are rendered inoperative. The pressure is raised at a rate of 0,13 MPa/s to the specified value and is maintained at that value for 15 min.

Water shall not leak from the appliance and there shall be no permanent deformation to such an extent that compliance with this standard is impaired.

NOTE 3 Heat exchangers incorporated in an appliance are subjected to a pressure test based on their working pressure.

NOTE 4 Damage to a protective coating on the inside of containers is not considered to be a hazard.

22.103 Pressure-relief devices of **closed water heaters** shall prevent the pressure in the container from exceeding the **rated pressure** by more than 0,1 MPa.

Compliance is checked by subjecting the container to a slowly increasing water pressure.

NOTE The pressure-relief device may be fitted during installation.

22.104 The outlet of **open-outlet water heaters** shall be constructed so that the water flow is not limited to such an extent that the container is subjected to a significant pressure.

NOTE This requirement is considered to be met if the cross-sectional area of the water outlet is not less than that of the inlet.

The vent pipe of **low pressure water heaters** shall have an internal diameter of at least 20 mm.

Compliance is checked by inspection and measurement.

22.105 Cistern-type water heaters shall be constructed so that the container is always at atmospheric pressure by means of a vent having an area of at least 30 mm² and a minimum dimension of at least 3 mm.

Compliance is checked by inspection and by measurement.

22.106 Closed water heaters shall incorporate a **thermal cut-out** providing **all-pole disconnection** and which operates independently from the **thermostat**. However, for appliances intended to be connected to fixed wiring, the neutral conductor need not be disconnected.

Compliance is checked by inspection.

22.107 Heating elements and thermal control sensors in contact with the outer surface of the container shall be held in position securely.

Compliance is checked by inspection.

22.108 Appliances for wall mounting shall have reliable provision for fixing to a wall, independent of the connection to the water mains.

Compliance is checked by inspection.

22.109 Appliances having a capacity of more than 15 l that cannot be emptied through a drain fitted in the water pipes shall incorporate means for draining that requires a **tool** for its operation.

Compliance is checked by inspection and by manual test.

NOTE 1 Residual water in the container below the end of the inlet pipe is disregarded.

NOTE 2 The means for draining may be combined with a pressure-relief valve.

22.110 Open-outlet water heaters having plastic containers shall be constructed to ensure that the appliance is only likely to be installed in the intended orientation.

NOTE Appliances marked with the mounting position adjacent to the water connections are considered to meet this requirement.

Compliance is checked by inspection.

22.111 Closed water heaters incorporating a heat exchanger shall be constructed so that during normal use the **thermal cut-out** does not operate due to heat from the exchanger.

Thermostatic valves, by-pass valves and similar controlling devices used for this purpose shall be supplied with the appliance.

Compliance is checked by inspection.

22.112 Closed water heaters shall be constructed so that repeated drawing off does not cause the water to boil.

Compliance is checked by the following test.

The appliance is operated as specified in Clause 11.

*When the **thermostat** has operated for the first time, water is drawn off at a rate of approximately 2 l/min or 10 % of the capacity of the appliance per minute, whichever is less, until the **thermostat** switches on again.*

When the **thermostat** next operates, water is drawn off again at the same rate until the **thermostat** switches on, this sequence being repeated until steady conditions are established.

The temperature of the water, measured by means of a thermocouple at the outlet, shall not exceed 98 °C.

23 Internal wiring

This clause of Part 1 is applicable.

24 Components

This clause of Part 1 is applicable except as follows.

24.1.4 Addition:

Thermal cut-outs incorporated in **closed water heaters** shall comply with the requirements for type 2B controls in Clauses 13, 15, 16 17 and 20 of IEC 60730-1, unless they are tested with the appliance.

24.101 Thermal cut-outs shall be non-self-resetting. They shall have a trip-free switching mechanism or be located so that they can only be reset after removal of a **non-detachable cover**.

Compliance is checked by inspection.

24.102 The operating temperature of the **thermal cut-out** of a **closed water heater** shall ensure that the water temperature cannot exceed either 99 °C or 130 °C.

Compliance is checked by the test of 24.102.1 for water temperatures not exceeding 99 °C or 24.102.2 for 130 °C.

24.102.1 *The appliance is operated under the conditions specified in Clause 11 until the **thermostat** operates for the first time. A quantity of water equal to 25 % of the capacity of the container is then drawn off so that it is replaced by cold water.*

*Immediately after the **thermostat** operates for the second time, it is short-circuited. The test is continued until the **thermal cut-out** operates. The outlet valve is then opened and the temperature of the water measured at the outlet.*

The temperature shall not exceed 99 °C.

24.102.2 *For appliances with vertically oriented metallic containers, a thermocouple is attached to the outer surface of the upper dome. If the container is horizontally oriented, two thermocouples are attached to the outer surface. The position of the thermocouple is shown in Figure 102a.*

For appliances with non-metallic containers, a thermocouple is positioned 50 mm below the upper inner surface of the container, as shown in one of the diagrams in Figure 102b.

*The appliance is operated at 1,15 times **rated power input** under **normal operation** with the outlet valve closed and **thermostats** short-circuited. The test is continued until the **thermal cut-out** operates.*

The temperature shall not exceed 130 °C.

25 Supply connection and external flexible cords

This clause of Part 1 is applicable except as follows.

25.1 Modification:

Appliances shall not incorporate an appliance inlet.

26 Terminals for external conductors

This clause of Part 1 is applicable.

27 Provision for earthing

This clause of Part 1 is applicable except as follows.

27.1 Addition:

For **class I water heaters**, the sheath of the heating element shall be permanently and reliably connected to the earthing terminal unless

- the container is provided with inlet and outlet pipes of metal that are permanently and reliably connected to the earthing terminal, and
- other **accessible metal parts** of the container in contact with the water are permanently and reliably connected to the earthing terminal.

28 Screws and connections

This clause of Part 1 is applicable.

29 Clearances, creepage distances and solid insulation

This clause of Part 1 is applicable.

30 Resistance to heat and fire

This clause of Part 1 is applicable except as follows.

30.1 Addition:

The temperature rises occurring during the tests of 19.2, 19.3 and 19.101 are not taken into account.

30.2.2 Not applicable.

31 Resistance to rusting

This clause of Part 1 is applicable.

32 Radiation, toxicity and similar hazards

This clause of Part 1 is applicable.

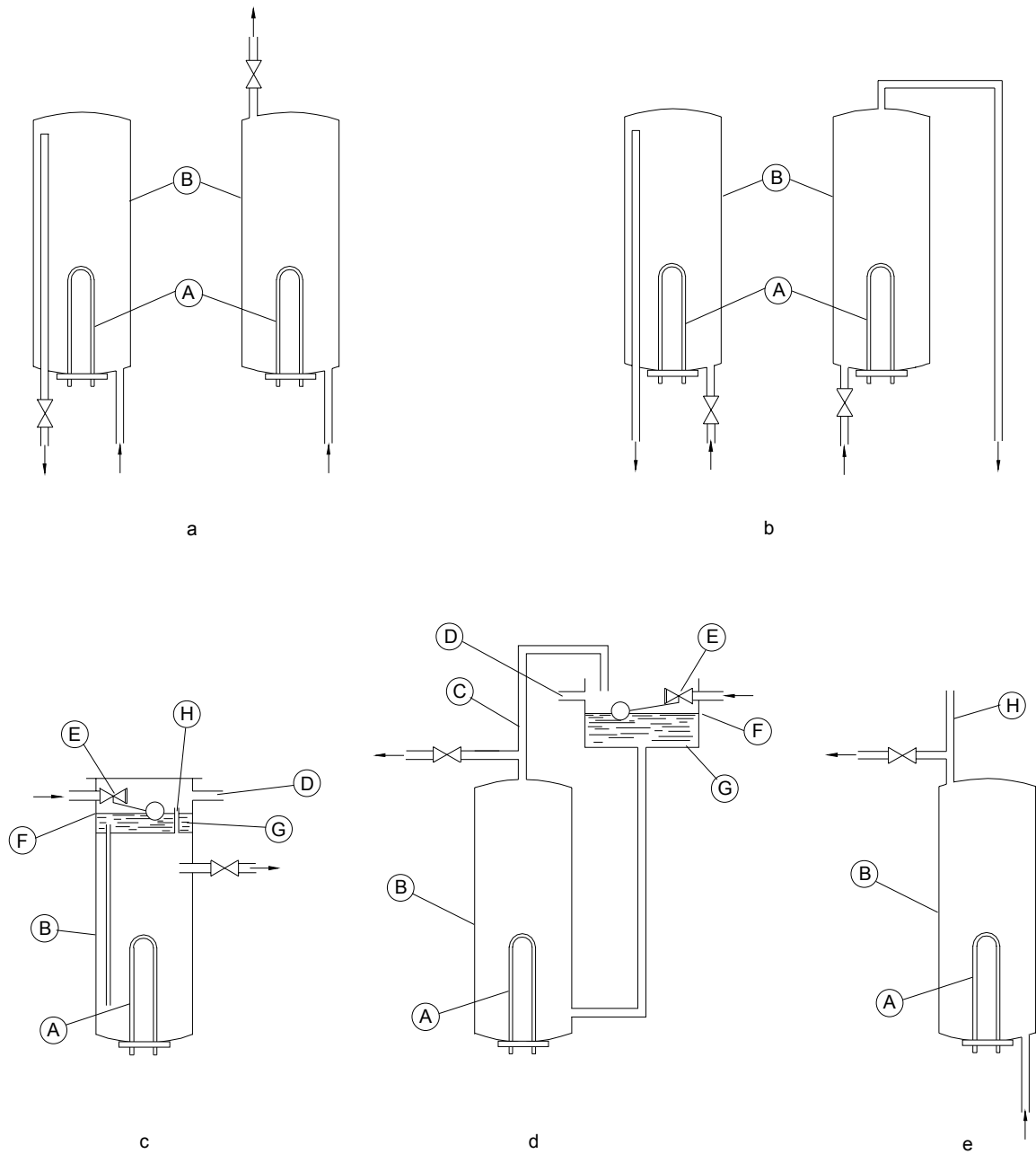

IEC 1269/02

Key

- A Heating element
- B Container
- C Expansion pipe
- D Overflow pipe
- E Ball valve
- F Water level
- G Cistern
- H Vent pipe

Type

- a Closed water heaters
- b Open-outlet water heaters
- c Cistern-type water heater
- d Cistern-fed water heater
- e Low-pressure water heater

Figure 101 – Examples of types of storage water heaters

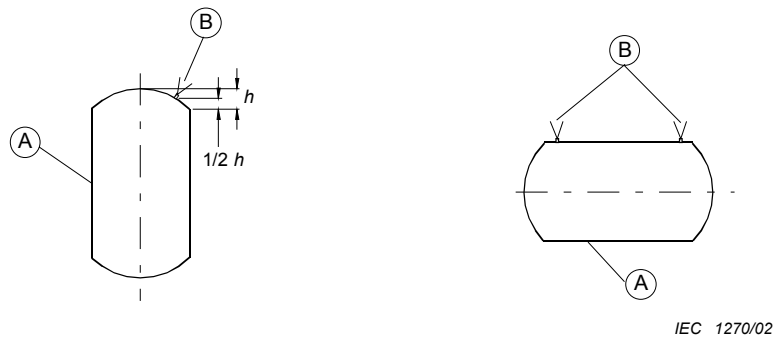
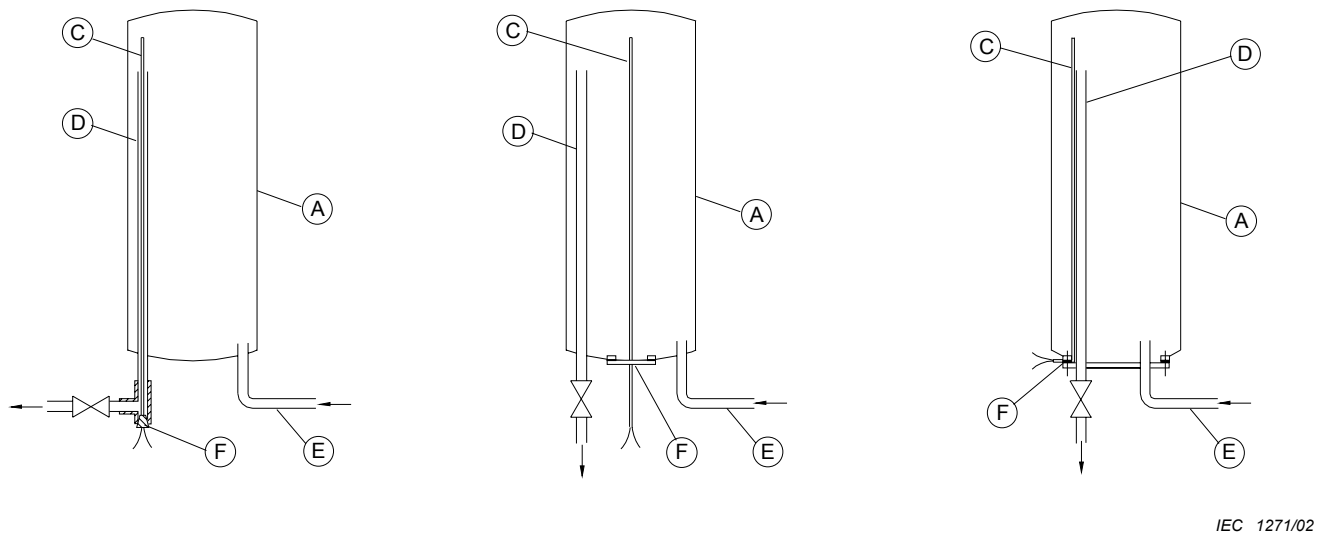

Figure 102a – Position of thermocouples for metallic containers



The thermocouple in a tube is inserted in the outlet pipe through a sealed entry

The thermocouple in a tube is inserted through a sealed entry

Insulated thermocouple wires are inserted through a sealed entry and attached to the outlet pipe

Figure 102b – Position of thermocouples for non-metallic containers

Key

- A Container
- B External thermocouple
- C Internal thermocouple
- D Outlet pipe
- E Inlet pipe
- F Sealed entry

Figure 102 – Examples of positions of the thermocouples

Annexes

The annexes of Part 1 are applicable except as follows.

Annex A (informative)

Routine tests

This annex of Part 1 is applicable except as follows.

A.101 Pressure test

The water container is subjected to a pressure test using a fluid.

When a liquid is used, the pressure is

- *for **closed water heaters**, 0,7 MPa for those having a **rated pressure** not greater than 0,6 MPa, and 1,1 times **rated pressure** for others;*
- *for **cistern-fed water heaters** and **low-pressure water heaters**, 1,1 times **rated pressure**;*
- *for **open-outlet water heaters**, 0,05 MPa;*
- *for **cistern-type water heaters**, 0,03 MPa.*

When gas is used, these pressures may be reduced but are to be sufficient to reveal leakage.

NOTE Care should be taken when testing **closed water heaters** with gas.

Leakage of the fluid is not to occur during the test.

Bibliography

The bibliography of Part 1 is applicable except as follows.

Addition:

IEC 60335-2-15, *Household and similar electrical appliances – Safety – Part 2-15: Particular requirements for appliances for heating liquids*

IEC 60335-2-35, *Household and similar electrical appliances – Safety – Part 2-35: Particular requirements for instantaneous water heaters*

IEC 60335-2-75, *Household and similar electrical appliances – Safety – Part 2-75: Particular requirements for commercial dispensing appliances and vending machines*



Standards Survey

The IEC would like to offer you the best quality standards possible. To make sure that we continue to meet your needs, your feedback is essential. Would you please take a minute to answer the questions overleaf and fax them to us at +41 22 919 03 00 or mail them to the address below. Thank you!

Customer Service Centre (CSC)

International Electrotechnical Commission

3, rue de Varembé

1211 Genève 20

Switzerland

or

Fax to: **IEC/CSC** at +41 22 919 03 00

Thank you for your contribution to the standards-making process.

A Prioritaire

Nicht frankieren
Ne pas affranchir



Non affrancare
No stamp required

RÉPONSE PAYÉE

SUISSE

Customer Service Centre (CSC)

International Electrotechnical Commission

3, rue de Varembé

1211 GENEVA 20

Switzerland



Q1 Please report on **ONE STANDARD** and **ONE STANDARD ONLY**. Enter the exact number of the standard: (e.g. 60601-1-1)

.....

Q2 Please tell us in what capacity(ies) you bought the standard (tick all that apply). I am the/a:

- purchasing agent
- librarian
- researcher
- design engineer
- safety engineer
- testing engineer
- marketing specialist
- other.....

Q3 I work for/in/as a: (tick all that apply)

- manufacturing
- consultant
- government
- test/certification facility
- public utility
- education
- military
- other.....

Q4 This standard will be used for: (tick all that apply)

- general reference
- product research
- product design/development
- specifications
- tenders
- quality assessment
- certification
- technical documentation
- thesis
- manufacturing
- other.....

Q5 This standard meets my needs: (tick one)

- not at all
- nearly
- fairly well
- exactly

Q6 If you ticked NOT AT ALL in Question 5 the reason is: (tick all that apply)

- standard is out of date
- standard is incomplete
- standard is too academic
- standard is too superficial
- title is misleading
- I made the wrong choice
- other

Q7 Please assess the standard in the following categories, using the numbers:

- (1) unacceptable,
- (2) below average,
- (3) average,
- (4) above average,
- (5) exceptional,
- (6) not applicable

- timeliness.....
- quality of writing.....
- technical contents.....
- logic of arrangement of contents
- tables, charts, graphs, figures.....
- other

Q8 I read/use the: (tick one)

- French text only
- English text only
- both English and French texts

Q9 Please share any comment on any aspect of the IEC that you would like us to know:

.....

.....

.....

.....

.....

.....

.....

.....

.....

.....

.....

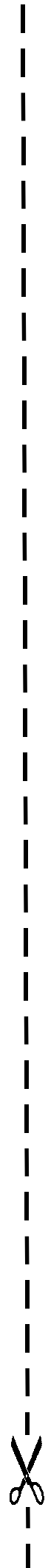

ISBN 2-8318-6387-2



9 782831 863870

ICS 91.140.65; 13.120

Typeset and printed by the IEC Central Office
GENEVA, SWITZERLAND