

INTERNATIONAL STANDARD

IEC
60335-2-11

Edition 6.1

2003-02

Edition 6:2002 consolidated with amendment 1:2003

Household and similar electrical appliances – Safety –

Part 2-11: Particular requirements for tumble dryers

*Appareils électrodomestiques et analogues –
Sécurité –*

*Partie 2-11:
Règles particulières pour les sèche-linge à tambour*



Reference number
IEC 60335-2-11:2002+A1:2003(E)

Publication numbering

As from 1 January 1997 all IEC publications are issued with a designation in the 60000 series. For example, IEC 34-1 is now referred to as IEC 60034-1.

Consolidated editions

The IEC is now publishing consolidated versions of its publications. For example, edition numbers 1.0, 1.1 and 1.2 refer, respectively, to the base publication, the base publication incorporating amendment 1 and the base publication incorporating amendments 1 and 2.

Further information on IEC publications

The technical content of IEC publications is kept under constant review by the IEC, thus ensuring that the content reflects current technology. Information relating to this publication, including its validity, is available in the IEC Catalogue of publications (see below) in addition to new editions, amendments and corrigenda. Information on the subjects under consideration and work in progress undertaken by the technical committee which has prepared this publication, as well as the list of publications issued, is also available from the following:

- **IEC Web Site (www.iec.ch)**
- **Catalogue of IEC publications**

The on-line catalogue on the IEC web site (http://www.iec.ch/searchpub/cur_fut.htm) enables you to search by a variety of criteria including text searches, technical committees and date of publication. On-line information is also available on recently issued publications, withdrawn and replaced publications, as well as corrigenda.
- **IEC Just Published**

This summary of recently issued publications (http://www.iec.ch/online_news/justpub/jp_entry.htm) is also available by email. Please contact the Customer Service Centre (see below) for further information.
- **Customer Service Centre**

If you have any questions regarding this publication or need further assistance, please contact the Customer Service Centre:

Email: custserv@iec.ch
Tel: +41 22 919 02 11
Fax: +41 22 919 03 00

INTERNATIONAL STANDARD

IEC 60335-2-11

Edition 6.1

2003-02

Edition 6:2002 consolidated with amendment 1:2003

Household and similar electrical appliances – Safety –

Part 2-11: Particular requirements for tumble dryers

*Appareils électrodomestiques et analogues –
Sécurité –*

*Partie 2-11:
Règles particulières pour les sèche-linge à tambour*

© IEC 2003 — Copyright - all rights reserved

No part of this publication may be reproduced or utilized in any form or by any means, electronic or mechanical, including photocopying and microfilm, without permission in writing from the publisher.

International Electrotechnical Commission, 3, rue de Varembé, PO Box 131, CH-1211 Geneva 20, Switzerland
Telephone: +41 22 919 02 11 Telefax: +41 22 919 03 00 E-mail: inmail@iec.ch Web: www.iec.ch



Commission Electrotechnique Internationale
International Electrotechnical Commission
Международная Электротехническая Комиссия

PRICE CODE

J

For price, see current catalogue

CONTENTS

FOREWORD	3
INTRODUCTION	5
1 Scope	6
2 Normative references	6
3 Definitions	6
4 General requirement	7
5 General conditions for the tests	7
6 Classification	7
7 Marking and instructions	7
8 Protection against access to live parts	9
9 Starting of motor-operated appliances	9
10 Power input and current	9
11 Heating	9
12 Void	10
13 Leakage current and electric strength at operating temperature	10
14 Transient overvoltages	10
15 Moisture resistance	10
16 Leakage current and electric strength	11
17 Overload protection of transformers and associated circuits	11
18 Endurance	11
19 Abnormal operation	11
20 Stability and mechanical hazards	12
21 Mechanical strength	13
22 Construction	13
23 Internal wiring	14
24 Components	14
25 Supply connection and external flexible cords	14
26 Terminals for external conductors	14
27 Provision for earthing	14
28 Screws and connections	15
29 Clearances, creepage distances and solid insulation	15
30 Resistance to heat and fire	15
31 Resistance to rusting	15
32 Radiation, toxicity and similar hazards	15
Annexes	17
Annex AA (normative) Rinsing agent	17
Bibliography	18
Figure 101 – Probe for measuring surface temperatures	16

INTERNATIONAL ELECTROTECHNICAL COMMISSION

**HOUSEHOLD AND SIMILAR ELECTRICAL APPLIANCES –
SAFETY –****Part 2-11: Particular requirements for tumble dryers**

FOREWORD

- 1) The IEC (International Electrotechnical Commission) is a worldwide organization for standardization comprising all national electrotechnical committees (IEC National Committees). The object of the IEC is to promote international co-operation on all questions concerning standardization in the electrical and electronic fields. To this end and in addition to other activities, the IEC publishes International Standards. Their preparation is entrusted to technical committees; any IEC National Committee interested in the subject dealt with may participate in this preparatory work. International, governmental and non-governmental organizations liaising with the IEC also participate in this preparation. The IEC collaborates closely with the International Organization for Standardization (ISO) in accordance with conditions determined by agreement between the two organizations.
- 2) The formal decisions or agreements of the IEC on technical matters express, as nearly as possible, an international consensus of opinion on the relevant subjects since each technical committee has representation from all interested National Committees.
- 3) The documents produced have the form of recommendations for international use and are published in the form of standards, technical specifications, technical reports or guides and they are accepted by the National Committees in that sense.
- 4) In order to promote international unification, IEC National Committees undertake to apply IEC International Standards transparently to the maximum extent possible in their national and regional standards. Any divergence between the IEC Standard and the corresponding national or regional standard shall be clearly indicated in the latter.
- 5) The IEC provides no marking procedure to indicate its approval and cannot be rendered responsible for any equipment declared to be in conformity with one of its standards.
- 6) Attention is drawn to the possibility that some of the elements of this International Standard may be the subject of patent rights. The IEC shall not be held responsible for identifying any or all such patent rights.

This part of International Standard IEC 60335 has been prepared by IEC technical committee 61: Safety of household and similar electrical appliances.

This consolidated version of IEC 60335-2-11 is based on the sixth edition (2002) [documents 61/2097/FDIS and 61/2128/RVD] and its amendment 1 (2003) [documents 61/2274/FDIS and 61/2324/RVD].

It bears the edition number 6.1.

A vertical line in the margin shows where the base publication has been modified by amendment 1.

This part 2 is to be used in conjunction with the latest edition of IEC 60335-1 and its amendments. It was established on the basis of the fourth edition (2001) of that standard.

NOTE 1 When "Part 1" is mentioned in this standard, it refers to IEC 60335-1.

This part 2 supplements or modifies the corresponding clauses of IEC 60335-1, so as to convert that publication into the IEC standard: Safety requirements for electric tumble dryers.

When a particular subclause of Part 1 is not mentioned in this part 2, that subclause applies as far as is reasonable. When this standard states "addition", "modification" or "replacement", the relevant text in Part 1 is to be adapted accordingly.

NOTE 2 The following numbering system is used:

- subclauses, tables and figures that are numbered starting from 101 are additional to those in Part 1;
- unless notes are in a new subclause or involve notes in Part 1, they are numbered starting from 101, including those in a replaced clause or subclause;
- additional annexes are lettered AA, BB, etc.

NOTE 3 The following print types are used:

- requirements: in roman type;
- *test specifications: in italic type;*
- notes: in small roman type.

Words in **bold** in the text are defined in Clause 3. When a definition concerns an adjective, the adjective and associated noun are also in bold.

The committee has decided that the contents of the base publication and its amendments will remain unchanged until 2005. At this date, the publication will be

- reconfirmed;
- withdrawn;
- replaced by a revised edition, or
- amended.

The following differences exist in the countries indicated below.

- 3.1.9: The textile material has different dimensions (USA).
- 6.2: Tumble dryers are not required to be IPX4 (USA).
- 7.1: An instruction concerning cleaning the lint trap is to be marked on the dryer in letters not less than 8 mm high and is to be conspicuous when the dryer door is open (Australia, New Zealand).
- 7.12: Actual articles of clothing can be specified instead and warnings are required to be marked on the appliance regarding the use of chemicals for cleaning (USA).
- 11.2: The test condition is different (USA).
- 11.7: This test is continued until steady conditions are established and different criteria are used to determine when steady conditions are reached (USA).
- 19.4: The test is different (USA).
- 19.9: A running overload test is carried out on automatically controlled tumble dryers (USA).
- 20.101: The requirement is applicable to door openings with a dimension exceeding 20 cm (Norway).
- 20.102: When considering accessibility to rotating drums, the maximum drum volume is 60 dm³ and the maximum door opening is 20 cm (USA).
- 20.103: This test is not carried out (USA).
- 22.104: The test is different (USA).
- 27.1: Earthing terminals and contacts are allowed to be electrically connected to the neutral conductor of a tumble dryer (USA)

INTRODUCTION

It has been assumed in the drafting of this International Standard that the execution of its provisions is entrusted to appropriately qualified and experienced persons.

This standard recognizes the internationally accepted level of protection against hazards such as electrical, mechanical, thermal, fire and radiation of appliances when operated as in normal use taking into account the manufacturer's instructions. It also covers abnormal situations that can be expected in practice.

This standard takes into account the requirements of IEC 60364 as far as possible so that there is compatibility with the wiring rules when the appliance is connected to the supply mains. However, national wiring rules may differ.

If an appliance within the scope of this standard also incorporates functions that are covered by another part 2 of IEC 60335, the relevant part 2 is applied to each function separately, as far as is reasonable. If applicable, the influence of one function on the other is taken into account.

This standard is a product family standard dealing with the safety of appliances and takes precedence over horizontal and generic standards covering the same subject.

An appliance that complies with the text of this standard will not necessarily be considered to comply with the safety principles of the standard if, when examined and tested, it is found to have other features which impair the level of safety covered by these requirements.

An appliance employing materials or having forms of construction differing from those detailed in the requirements of this standard may be examined and tested according to the intent of the requirements and, if found to be substantially equivalent, may be considered to comply with the standard.

HOUSEHOLD AND SIMILAR ELECTRICAL APPLIANCES – SAFETY –

Part 2-11: Particular requirements for tumble dryers

1 Scope

This clause of Part 1 is replaced by the following.

This International Standard deals with the safety of electric **tumble dryers** intended for household and similar purposes, their **rated voltage** being not more than 250 V for single-phase appliances and 480 V for other appliances.

NOTE 101 This standard applies to the drying function of washing machines having a drying cycle.

Appliances not intended for normal household use but which nevertheless may be a source of danger to the public, such as appliances intended to be used by laymen in shops, in light industry and on farms are within the scope of this standard.

NOTE 102 Examples of such appliances are **tumble dryers** for communal use in blocks of flats or in launderettes.

As far as is practicable, this standard deals with the common hazards presented by appliances that are encountered by all persons in and around the home. However, in general, it does not take into account

- the use of appliances by young children or infirm persons without supervision;
- playing with the appliance by young children.

NOTE 103 Attention is drawn to the fact that

- for appliances intended to be used in vehicles or on board ships or aircraft, additional requirements may be necessary;
- in many countries additional requirements are specified by the national health authorities, the national authorities responsible for the protection of labour, the national water supply authorities and similar authorities.

NOTE 104 This standard does not apply to

- appliances intended exclusively for industrial purposes;
- appliances intended to be used in locations where special conditions prevail, such as the presence of a corrosive or explosive atmosphere (dust, vapour or gas).

2 Normative references

This clause of Part 1 is applicable.

3 Definitions

This clause of Part 1 is applicable except as follows.

3.1.9 *Replacement:*

normal operation

operation of the appliance under the following conditions

The appliance is operated filled with textile material having a mass in the dry condition equal to the maximum load stated in the instructions.

The textile material consists of pre-washed double-hemmed cotton sheets having dimensions approximately 70 cm × 70 cm and a specific mass between 140 g/m² and 175 g/m² in the dry

condition. The textile material is soaked with water having a temperature of $25\text{ °C} \pm 5\text{ °C}$ and a mass equal to that of the textile material.

If the drying function can automatically follow the washing function in a washing machine, the appliance is not separately loaded. The appliance is operated with the maximum quantity of textile material stated in the instructions for the combined washing-drying cycle.

NOTE 101 Cotton having a water content not exceeding 10 % is considered to be in the dry condition. Cotton conditioned for 24 h in still air, having a temperature of $20\text{ °C} \pm 2\text{ °C}$, a relative humidity between 60 % and 70 % and a pressure between 860 mbar and 1 060 mbar, will contain approximately 7 % water.

3.101

tumble dryer

appliance in which textile material is dried by tumbling in a rotating drum through which heated air is blown

3.102

condensation-type tumble dryer

tumble dryer in which the air used for the drying process is dehumidified by cooling

4 General requirement

This clause of Part 1 is applicable.

5 General conditions for the tests

This clause of Part 1 is applicable.

6 Classification

This clause of Part 1 is applicable except as follows.

6.2 Addition:

Appliances shall be at least IPX4.

7 Marking and instructions

This clause of Part 1 is applicable except as follows.

7.6 Addition:



[symbol 5036 of IEC 60417-1]

dangerous voltage



[symbol 5041 of IEC 60417-1]

caution, hot surface

7.10 Addition:

If the **off position** is only indicated by letters, the word "off" shall be used.

7.12 Addition:

The instructions for use shall state

- the maximum mass of dry textile material in kilograms to be used in the appliance;
- that the tumble dryer is not to be used if industrial chemicals have been used for cleaning;
- that the lint trap has to be cleaned frequently, if applicable;
- that lint must not to be allowed to accumulate around the tumble dryer (not applicable for appliances intended to be vented to the exterior of the building);
- that adequate ventilation has to be provided to avoid the back flow of gases into the room from appliances burning other fuels, including open fires.

NOTE 101 This instruction is not required if the **tumble dryer** discharges the air into the room.

If symbols 5036 or 5041 of IEC 60417-1 are used, their meaning shall be explained.

7.12.1 Addition:

The installation instructions shall state

- for **condensation-type tumble dryers** intended to be connected to the water mains
 - that the appliance is to be connected to the water mains using a new hose-set and old hose-sets should not be reused;

NOTE 101 This instruction is not required if the hose is permanently attached to the appliance.

- the maximum permissible inlet water pressure, in megapascals;
- the minimum permissible inlet water pressure, in megapascals, if this is necessary for correct operation of the appliance;
- for appliances with ventilation openings in the base, that a carpet must not obstruct the openings;
- that exhaust air must not be discharged into a flue which is used for exhausting fumes from appliances burning gas or other fuels.

NOTE 102 This instruction is not required if the **tumble dryer** discharges the air into the room.

- that the appliance must not be installed behind a lockable door, a sliding door or a door with a hinge on the opposite side to that of the tumble dryer.

If the installation instructions state that the **tumble dryer** can be placed on top of a washing machine, they shall state which washing machines are suitable. Instructions shall be given for the assembly of the **tumble dryer** and washing machine. The instructions shall state how to obtain any fixing attachments required, unless they are supplied with the appliance.

7.14 Addition:

The height of symbol 5036 of IEC 60417-1 shall be at least 5 mm and the height of symbol 5041 shall be at least 15 mm.

Compliance is checked by measurement.

7.101 The enclosure of magnetic valves, and similar components incorporated in external hoses for direct connection to the water mains, shall be marked with symbol 5036 of IEC 60417-1 if their **working voltage** exceeds **extra-low voltage**.

NOTE This symbol is a warning sign and the rules of ISO 3864 apply.

Compliance is checked by inspection.

7.102 The rear surface, other than that of **fixed appliances**, shall be marked with symbol 5041 of IEC 60417-1 if its temperature rise exceeds the limits specified in 11.8 for **accessible front surfaces**.

NOTE This symbol is a warning sign and the rules of ISO 3864 apply.

Compliance is checked by inspection.

8 Protection against access to live parts

This clause of Part 1 is applicable.

9 Starting of motor-operated appliances

This clause of Part 1 is not applicable.

10 Power input and current

This clause of Part 1 is applicable.

11 Heating

This clause of Part 1 is applicable except as follows.

11.2 Addition:

Lint traps are cleaned and then 50 % of the area of the filter is blocked.

11.3 Addition:

*Temperature rises of the **accessible front surface** are measured using the probe of Figure 101. The probe is applied with a force of $4\text{ N} \pm 1\text{ N}$ to the surface in such a way that the best possible contact between the probe and the surface is ensured.*

NOTE 101 Any measuring instrument giving the same results as the probe may be used.

11.7 Replacement:

Appliances incorporating a timer, a humidity sensing control or other time-limiting control are operated in cycles. Each cycle comprises an operating period having a duration equal to the maximum time that can be provided by the control and a rest period of 4 min during which the appliance is reloaded.

The test may be ended if the temperature rise of any part does not exceed the value determined during the preceding cycle by more than 8 K.

Appliances having a combined washing-drying cycle are operated with the drying programme resulting in the highest temperature rise.

Other appliances are operated continuously until steady conditions are established.

11.8 Addition:

The temperature rises of the **accessible front surface** shall not exceed the following values:

– metal and painted metal parts	60 K
– vitreous-enamelled metal parts	65 K
– glass and ceramic parts	65 K
– plastic parts having a thickness exceeding 0,3 mm	80 K

The temperature rise limit of 80 K also applies to plastic material having a metal finish of thickness less than 0,1 mm.

NOTE 101 When the thickness of the plastic coating does not exceed 0,3 mm, the temperature rise limits of the supporting material applies.

The temperature rises are measured with the door closed.

12 Void

13 Leakage current and electric strength at operating temperature

This clause of Part 1 is applicable except as follows.

13.2 Modification:

For **stationary class I appliances**, the leakage current shall not exceed 3,5 mA, or 1 mA/kW rated power input with a limit of 5 mA, whichever is higher.

14 Transient overvoltages

This clause of Part 1 is applicable.

15 Moisture resistance

This clause of Part 1 is applicable except as follows.

15.1 Addition:

Magnetic valves and similar components incorporated in external hoses for connection to the water mains are subjected to the test specified for IPX7 appliances.

15.2 Modification:

The test is carried out with the drum filled with wet textile material as specified for **normal operation**, the mass of the water, however, being approximately 1,5 times the mass of the dry textile material.

Appliances intended to be connected to the water mains are operated with the outlet of the condensation circuit blocked. The inlet valve is held open and the filling continued for 1 min after first evidence of overflow or for 5 min after a **protective device** operates to stop the flow. Doors are opened but interlocks are not forced.

For appliances having a working surface, 0,5 l of water containing approximately 1 % NaCl and 0,6 % of rinsing agent, as specified in Annex AA, is poured over the top of the appliance, the controls being placed in the on position. The controls are then operated through their working range, this operation being repeated after a period of 5 min.

*The appliance shall then withstand the electric strength test of 16.3 and inspection shall show that there is no trace of water on insulation that could result in a reduction of **clearances** and **creepage distances** below the values specified in Clause 29.*

16 Leakage current and electric strength

This clause of Part 1 is applicable except as follows.

16.2 Modification:

*For **stationary class I appliances**, the leakage current shall not exceed 1 mA, or 1 mA/kW rated power input with a limit of 5 mA, whichever is higher.*

17 Overload protection of transformers and associated circuits

This clause of Part 1 is applicable.

18 Endurance

This clause of Part 1 is not applicable.

19 Abnormal operation

This clause of Part 1 is applicable except as follows.

19.1 Modification:

Instead of being subjected to the tests of 19.2 and 19.3, appliances are subjected to the tests of 19.101 and 19.102, as applicable.

Addition:

If operation without water is a more unfavourable condition for appliances connected to the water mains, the tests are carried out with the water valve closed. This valve is not closed after the appliance has started to operate.

19.4 Replacement:

*The appliance is operated under the conditions specified in Clause 11 but with dry textile material. Controls that limit the temperature during the test of Clause 11 and all **self-resetting thermal cut-outs** that protect the heating elements are short-circuited simultaneously. The test is terminated at the end of the maximum period allowed by a timer.*

*For **condensation-type tumble dryers**, the test is repeated, but with 75 % of the air outlet of the condenser blocked. The test is then carried out again with the air outlet fully blocked.*

19.9 Not applicable.

19.13 *Addition:*

The textile material shall not ignite and shall show no charring or glowing.

NOTE 101 Light-brown colouring of the textile material or slight emission of smoke is ignored.

19.101 *The appliance is operated under the conditions specified in Clause 11 but with dry textile material and the drum belt removed. The duration of the test is 90 min or for the maximum period allowed by a timer.*

If air circulation is likely to be prevented due to a fault condition, the test is repeated but with the drum belt in position and with the air circulation stopped.

NOTE Care is to be taken to ensure that the textile material is tumbling properly by reducing the load if necessary.

If both of these conditions are likely to occur simultaneously, the tests are combined.

19.102 *Appliances that permit test probe C of IEC 61032 to gain access to spaces containing **live parts** located below holes in the drum are tested for short circuit conditions. The short circuit is applied at the most unfavourable place between **live parts** and between **live parts** and other metal parts, if such a short circuit can be made by a pin having a diameter of approximately 1 mm and any length up to 50 mm. The appliance is operated as specified in Clause 11 but with dry textile material.*

19.103 There shall be no risk of fire due to textile material coming into contact with a lamp cover.

Compliance is checked by the following test.

*Ten layers of cheesecloth are placed over the lamp cover. The appliance is supplied at **rated voltage** with the door open until steady conditions are established. The temperature rise of the cover shall not exceed 150 K.*

20 Stability and mechanical hazards

This clause of Part 1 is applicable except as follows.

20.1 *Modification:*

The test with the angle of inclination increased to 15° is not carried out.

20.101 It shall not be possible to open the door while the appliance is operating unless an interlock is provided that disconnects the motor before the door opening exceeds 75 mm. It shall not be possible to start the motor while the door opening exceeds 75 mm. For appliances with a door opening having a dimension exceeding 200 mm and a drum having a volume exceeding 60 dm³, it shall not be possible to start the motor until a separate means which controls the movement of the drum is operated manually.

*Compliance is checked by inspection, by measurement and by manual test, the appliance being supplied at **rated voltage** and operating under **normal operation**.*

If means to prevent the door opening incorporates a coil or similar component to lock the door in the closed position, the component is energized and de-energized 6 000 times, six times a minute or at the rate imposed by the construction of the appliance if this is lower.

The locking means and its components shall be fit for further use.

NOTE The door is opened and closed during the test if this is necessary for the mechanical operation of the interlock.

20.102 For appliances with a door opening having a dimension exceeding 200 mm and a drum having a volume exceeding 60 dm³, it shall be possible to open the door from the inside with a force not exceeding 70 N.

NOTE 1 This requirement does not apply to washing machines having a drying function.

NOTE 2 If the appliance is supplied with a decorative door, the test is carried out with this door closed.

Compliance is checked by inspection, by measurement and by applying a force of 70 N perpendicular to the plane of the door at a point furthest from the hinges.

NOTE The force may be applied to the outside of the door.

20.103 Appliances with horizontally hinged doors shall have adequate stability when the open door is subjected to a load.

Compliance is checked by the following test.

The empty appliance is placed on a horizontal surface and a mass of 23 kg applied to the centre of the open door. The appliance shall not tilt and the door and hinges shall not be damaged to such an extent that compliance with this standard is impaired.

NOTE 1 **Built-in appliances** and top-loading appliances are not subjected to this test.

NOTE 2 The test is carried out with the **tumble dryer** placed on a horizontal surface, even if it can be stacked on top of a washing machine.

21 Mechanical strength

This clause of Part 1 is applicable.

22 Construction

This clause of Part 1 is applicable except as follows.

22.101 Heating elements shall be located or guarded so that they cannot be contacted by textile material.

Compliance is checked by inspection.

22.102 Interlocks shall be constructed so that unexpected operation of the appliance is unlikely to occur while the door is open.

Compliance is checked by inspection and by attempting to release the interlock by means of test probe B of IEC 61032.

22.103 Condensation-type tumble dryers intended to be connected to the water mains shall withstand the water pressure expected in normal use.

Compliance is checked by connecting the appliance to a water supply having a static pressure equal to twice the maximum permissible inlet water pressure or 1,2 MPa, whichever is higher, for a period of 5 min.

There shall be no leakage from any part, including the inlet water hose.

22.104 If the instructions state that the **tumble dryer** can be placed on top of a washing machine this shall be possible without the **tumble dryer** tilting or falling.

Compliance is checked by inspection and by the following test.

*The washing machine and **tumble dryer** are assembled together in accordance with the instructions. The combination is placed in the most unfavourable orientation on a surface that is inclined at 5° to the horizontal. Each appliance is supplied at **rated voltage** and operated under **normal operation** in turn.*

*The appliances shall not tilt and the **tumble dryer** shall not fall off the washing machine.*

23 Internal wiring

This clause of Part 1 is applicable except as follows.

23.101 The insulation and sheath of internal wiring for the supply of magnetic valves and similar components incorporated in external hoses shall be at least equivalent to light polyvinyl chloride sheathed flexible cord (code designation 60227 IEC 52).

Compliance is checked by inspection.

NOTE The mechanical characteristics specified in IEC 60227 are not checked.

24 Components

This clause of Part 1 is applicable except as follows.

24.1.4 Addition:

The number of cycles of operation for programmers is 3 000.

24.101 Thermal cut-outs incorporated in **tumble dryers** for compliance with 19.4 shall not be self-resetting.

Compliance is checked by inspection.

25 Supply connection and external flexible cords

This clause of Part 1 is applicable.

26 Terminals for external conductors

This clause of Part 1 is applicable.

27 Provision for earthing

This clause of Part 1 is applicable.

28 Screws and connections

This clause of Part 1 is applicable.

29 Clearances, creepage distances and solid insulation

This clause of Part 1 is applicable except as follows.

29.2 Addition:

The microenvironment is pollution degree 3, and the insulation shall have a CTI of not less than 250, unless the insulation is enclosed or located so that it is unlikely to be exposed to pollution due to condensation produced by the appliance during normal use

30 Resistance to heat and fire

This clause of Part 1 is applicable except as follows.

30.2.2 Not applicable.

30.101 Non-metallic materials in close proximity to heating elements and on which lint could accumulate shall be resistant to spread of fire. This requirement also applies to parts on which burning lint could fall.

Compliance is checked by subjecting non-metallic surfaces located within 75 mm of the heating element to the needle-flame test of Annex E. The test is also applied to surfaces located directly below the heating element. However, parts shielded by a barrier that meets the needle-flame test are not tested.

NOTE It is considered that burning lint will not fall through a barrier with openings having a dimension less than 3 mm.

The needle-flame test is not carried out on

- *material classified as V-0 or V-1 according to IEC 60695-11-10, provided that the test sample was no thicker than the relevant part;*
- *rotating parts of fans;*
- *small parts as defined in IEC 60695-2-11.*

31 Resistance to rusting

This clause of Part 1 is applicable.

32 Radiation, toxicity and similar hazards

This clause of Part 1 is applicable.

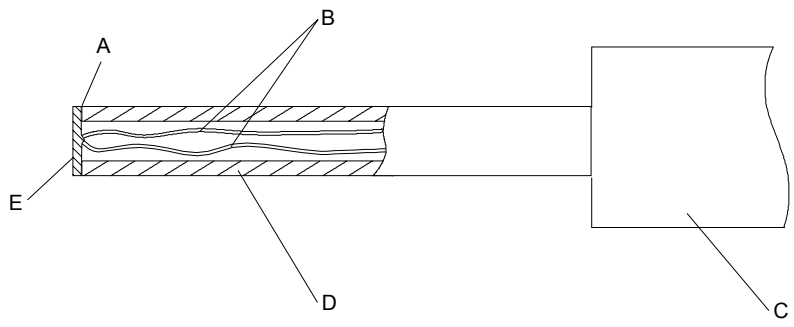

IEC 807/02

Key

- A Adhesive
- B Thermocouple wires 0,3 mm diameter to IEC 60584-1 Type K (chrome alumel)
- C Handle arrangement permitting a contact force of $4 \text{ N} \pm 1 \text{ N}$
- D Polycarbonate tube: inside diameter 3 mm, outside diameter 5 mm
- E Tinned copper disc: 5 mm diameter, 0,5 mm thick

NOTE The contact face of the disc is to be flat.

Figure 101 – Probe for measuring surface temperatures

Annexes

The annexes of Part 1 are applicable except as follows.

Annex AA (normative)

Rinsing agent

The composition of the rinsing agent is as follows.

Substance	Parts by mass %
Plurafac LF 221 ¹⁾	15,0
Cumene sulfonate (40 % solution)	11,5
Citric acid (anhydrous)	3,0
Deionized water	70,5

The rinsing agent has the following properties:

- viscosity, 17 mPa·s;
- pH, 2,2 (1 % in water).

NOTE 1 Any commercially available rinsing agent may be used, but if there is any doubt with regards to the test results, this composition is to be used.

NOTE 2 The composition of the rinsing agent is extracted from IEC 60436.

¹⁾ Plurafac LF 221 is the trade name of a product supplied by BASF. This information is given for the convenience of users of this International Standard and does not constitute an endorsement by IEC of this product.

Bibliography

The bibliography of Part 1 is applicable except as follows.

Addition:

IEC 60436, *Methods for measuring the performance of dishwashers*

IEC 61770, *Electric appliances connected to the water mains – Avoidance of backsiphonage and failure of hose-sets*

ISO 3864, *Safety colours and safety signs*



Standards Survey

The IEC would like to offer you the best quality standards possible. To make sure that we continue to meet your needs, your feedback is essential. Would you please take a minute to answer the questions overleaf and fax them to us at +41 22 919 03 00 or mail them to the address below. Thank you!

Customer Service Centre (CSC)

International Electrotechnical Commission

3, rue de Varembé

1211 Genève 20

Switzerland

or

Fax to: **IEC/CSC** at +41 22 919 03 00

Thank you for your contribution to the standards-making process.

A Prioritaire

Nicht frankieren
Ne pas affranchir



Non affrancare
No stamp required

RÉPONSE PAYÉE

SUISSE

Customer Service Centre (CSC)

International Electrotechnical Commission

3, rue de Varembé

1211 GENEVA 20

Switzerland



Q1 Please report on **ONE STANDARD** and **ONE STANDARD ONLY**. Enter the exact number of the standard: (e.g. 60601-1-1)

.....

Q2 Please tell us in what capacity(ies) you bought the standard (tick all that apply). I am the/a:

- purchasing agent
- librarian
- researcher
- design engineer
- safety engineer
- testing engineer
- marketing specialist
- other.....

Q3 I work for/in/as a: (tick all that apply)

- manufacturing
- consultant
- government
- test/certification facility
- public utility
- education
- military
- other.....

Q4 This standard will be used for: (tick all that apply)

- general reference
- product research
- product design/development
- specifications
- tenders
- quality assessment
- certification
- technical documentation
- thesis
- manufacturing
- other.....

Q5 This standard meets my needs: (tick one)

- not at all
- nearly
- fairly well
- exactly

Q6 If you ticked NOT AT ALL in Question 5 the reason is: (tick all that apply)

- standard is out of date
- standard is incomplete
- standard is too academic
- standard is too superficial
- title is misleading
- I made the wrong choice
- other

Q7 Please assess the standard in the following categories, using the numbers:

- (1) unacceptable,
- (2) below average,
- (3) average,
- (4) above average,
- (5) exceptional,
- (6) not applicable

- timeliness.....
- quality of writing.....
- technical contents.....
- logic of arrangement of contents
- tables, charts, graphs, figures.....
- other

Q8 I read/use the: (tick one)

- French text only
- English text only
- both English and French texts

Q9 Please share any comment on any aspect of the IEC that you would like us to know:

.....
.....
.....
.....
.....
.....
.....
.....
.....
.....



ISBN 2-8318-6863-7



9 782831 868639

ICS 13.120; 97.060

Typeset and printed by the IEC Central Office
GENEVA, SWITZERLAND