



FEATURES

- Cell Number Selection Function to Select 3 or 4 cells Protection.
- Ultra-Low Quiescent Current at 17μA (4-Cell, V_{CELL}=3.5V).
- Ultra-Low Power-Down Current at 2.2μA (4-Cell, V_{CELL}=2.3V)
- Wide Supply Voltage Range: 2V to 18V.
- Precision Overcharge Protection Voltage:
 - 4.35V± 30mV for the AIC1804A
 - 4.30V± 30mV for the AIC1804B
 - 4.25V± 30mV for the AIC1804C
 - 4.20V± 30mV for the AIC1804D
- Externally Set Overcharge, Overdischarge and Overcurrent Delay Time.
- Built-in Cell-balancing Bleeding Network under Overcharge Condition.
- Three Detection Levels for Overcurrent Protection.

DESCRIPTION

The AIC1804 is designed to protect the lithium-ion battery from damage or degrading the lifetime due to overcharging, overdischarging and overcurrent for three- or four-cell lithium-ion battery powered systems such as notebook PCs. It can also provide the cell-balancing “bleeding” function to automatically discharge the overcharged cell until the overcharge condition is released.

Safe and full utilization charging is ensured by the accurate ±30mV overcharge detection. Four different specification values for overcharge protection voltage are provided for various protection requirements. The very low standby current drains little current from the cell while in storage.

APPLICATIONS

- Protection IC for Three- or Four-Cell Lithium-Ion Battery Packs.

TYPICAL APPLICATION CIRCUIT

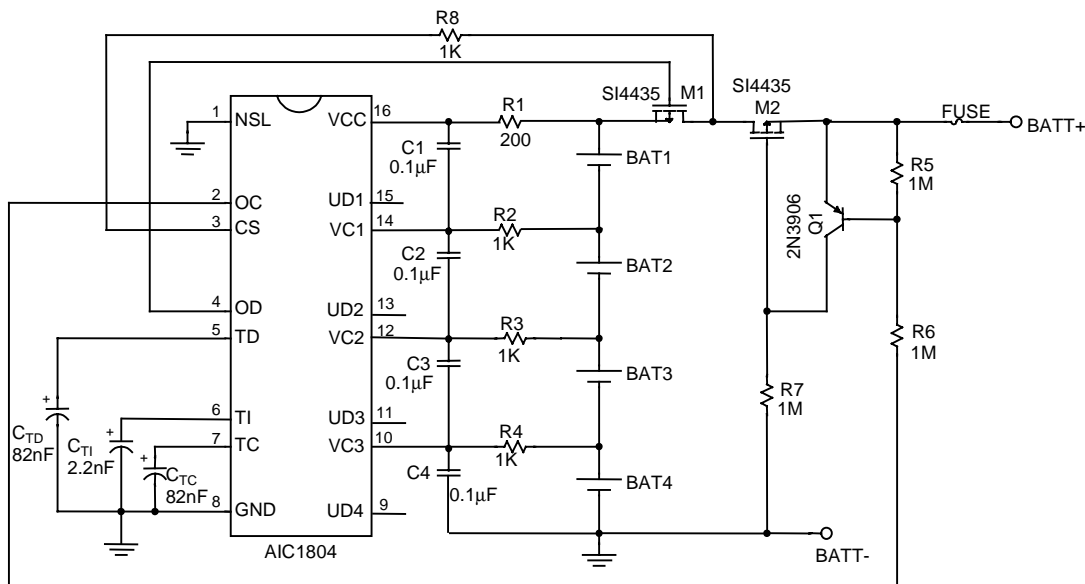

Protection Circuit for Four-Cell Lithium-Ion Battery Pack



ORDERING INFORMATION

AIC1804 XXX

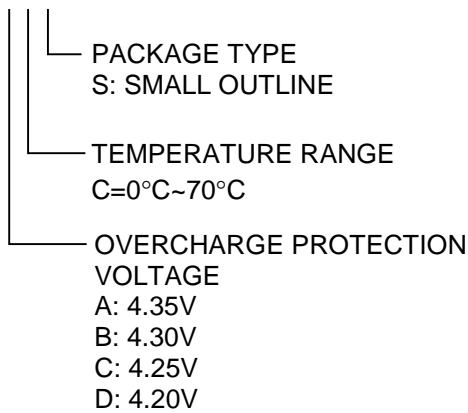

ORDER NUMBER	PIN CONFIGURATION
AIC1804ACS AIC1804BCS AIC1804CCS AIC1804DCS (PLASTIC SO)	TOP VIEW

ABSOLUTE MAXIMUM RATINGS

Supply Voltage	18V
DC Voltage Applied on other Pins	18V
Operating Temperature Range.....	-20°C~70°C
Storage Temperature Range	- 65°C ~125°C

TEST CIRCUIT

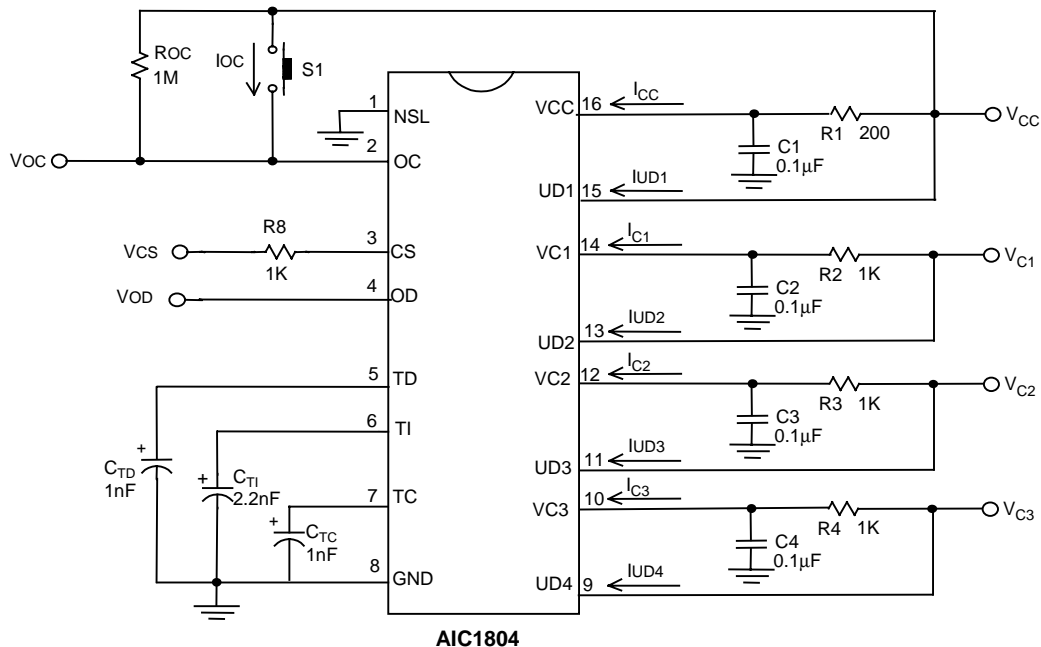



ELECTRICAL CHARACTERISTICS (Ta=25°C, unless otherwise specified.)

PARAMETER	TEST CONDITIONS	SYMBOL	MIN.	TYP.	MAX.	UNIT
VCC Pin Input Current in Normal Mode	V _{CELL} =3.5V	I _{CC}		17	26	μA
VC1 Pin Input Current in Normal Mode	V _{CELL} =3.5V	I _{C1}		0.7	1.8	μA
VC2 Pin Input Current in Normal Mode	V _{CELL} =3.5V	I _{C2}		0.4	1.0	μA
VC3 Pin Input Current in Normal Mode	V _{CELL} =3.5V	I _{C3}		0.2	0.5	μA
Vcc Pin Input Current in Power-Down Mode	V _{CELL} =2.3V	I _{CC(PD)}		2.2	4.0	μA
VC1,VC2,VC3 Input Current in Power-Down Mode	V _{CELL} =2.3V	I _{C(PD)}		0.01	0.15	μA
Overcharge Protection Voltage	AIC1804A	V _{OCV}	4.32	4.35	4.38	V
	AIC1804B		4.27	4.30	4.33	
	AIC1804C		4.22	4.25	4.28	
	AIC1804D		4.17	4.20	4.23	
Overcharge Hysteresis Voltage		V _{HYS}	150	200	250	mV
Overdischarge Protection Voltage		V _{ODP}	2.27	2.40	2.53	V
Overdischarge Release Voltage		V _{ODR}	2.85	3.00	3.15	V
Overcurrent Protection Voltage	V _{CELL} =3.5V	V _{OIP}	135	150	165	mV
Overcharge Delay Time	V _{CELL1} =V _{OCV} - 30mV →V _{OCV} +30mV V _{CELL2} = V _{CELL3} = V _{CELL4} = 3.5V, C _{TC} =1nF	T _{OC}	10	21	32	mS
Overdischarge Delay Time	V _{CELL1} = 2.5V→ 2.3V V _{CELL2} = V _{CELL3} = V _{CELL4} = 3.5V, C _{TD} =1nF	T _{OD}	10	21	32	mS
Overcurrent Delay Time (1)	V _{CELL} = 3.5V, 0.15V<V _{CC} - V _{CS} <0.3V, C _{TI} =2.2nF	T _{OI1}	7	15	23	mS
Overcurrent Delay Time (2)	V _{CELL} =3.5V, 0.3V<V _{CC} -V _{CS} <1.0V	T _{OI2}	2	4	6	mS

**ELECTRICAL CHARACTERISTICS** (Ta=25°C, unless otherwise specified.)

PARAMETER	TEST CONDITIONS	SYMBOL	MIN.	TYP.	MAX.	UNIT
Overcurrent Delay Time (3)	$V_{CELL}=3.5V, V_{CC}-V_{CS}>1.0V$	T_{OIS}	150	300	450	μS
OC Pin Sink Current	$V_{CELL1}=4.4V,$ $V_{CELL2}=V_{CELL3}=V_{CELL4}=3.5V,$ OC Pin Short to V_{CC}	I_{OC}	2.2	3.2	4.2	mA
OD Pin Output "H" Voltage		V_{DH}	$V_{CC}-0.15V$	$V_{CC}-0.03V$		V
OD Pin Output "L" Voltage		V_{DL}		0.01	0.15	V
Charge Detection Threshold Voltage	$V_{CELL}=2.3V$	V_{CH}		$V_{CC}+0.4$	$V_{CC}+0.55$	V
UD1 Pin Cell-Balancing Bleeding Current	$V_{CELL1}=4.4V,$ $V_{CELL2}=V_{CELL3}=V_{CELL4}=3.5V$	I_{UD1}	6.5	9.3	12.1	mA
UD2 Pin Cell-Balancing Bleeding Current	$V_{CELL2}=4.4V,$ $V_{CELL1}=V_{CELL3}=V_{CELL4}=3.5V$	I_{UD2}	6.3	9.0	11.7	mA
UD3 Pin Cell-Balancing Bleeding Current	$V_{CELL3}=4.4V,$ $V_{CELL1}=V_{CELL2}=V_{CELL4}=3.5V$	I_{UD3}	6.2	8.8	11.4	mA
UD4 Pin Cell-Balancing Bleeding Current	$V_{CELL4}=4.4V,$ $V_{CELL1}=V_{CELL2}=V_{CELL3}=3.5V$	I_{UD4}	6.4	9.2	12.0	mA

Note: V_{CELL} means the battery cell voltage. Therefore,

$$V_{CELL1} = V_{CC} - V_{C1}$$

$$V_{CELL2} = V_{C1} - V_{C2}$$

$$V_{CELL3} = V_{C2} - V_{C3}$$

$$V_{CELL4} = V_{C3}$$



TYPICAL PERFORMANCE CHARACTERISTICS

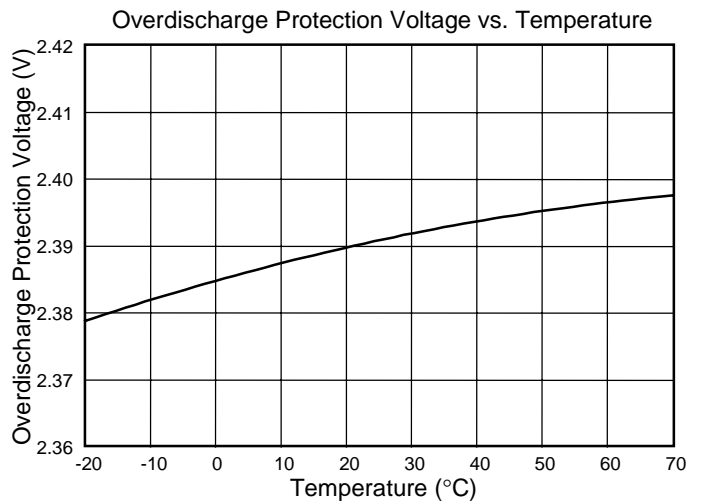
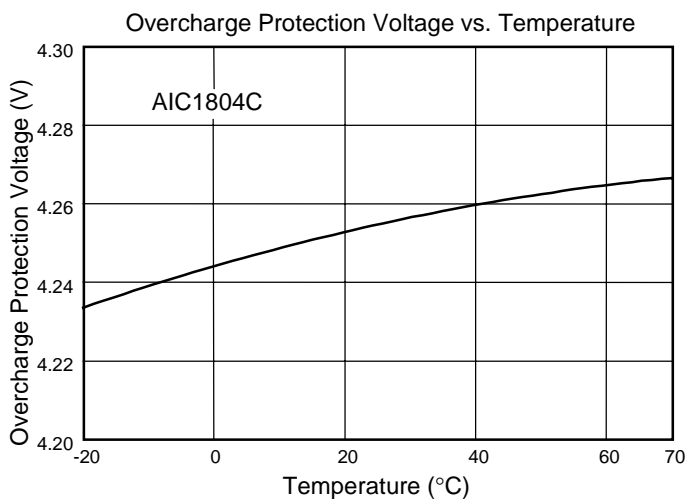
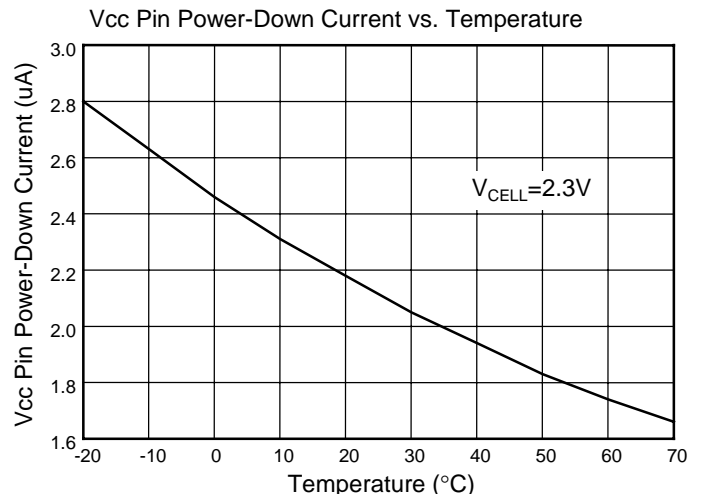
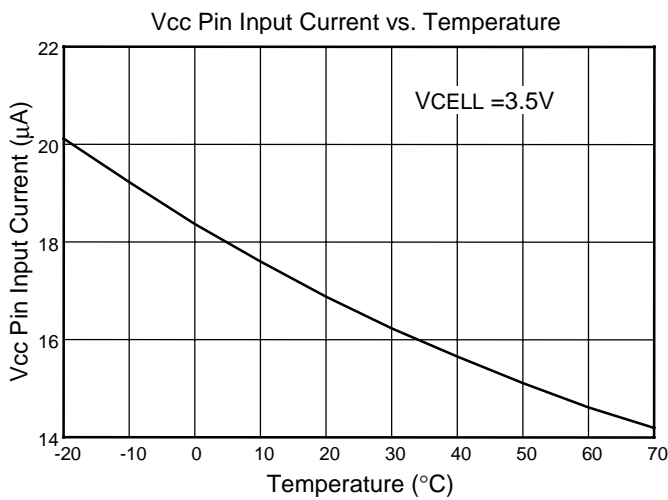
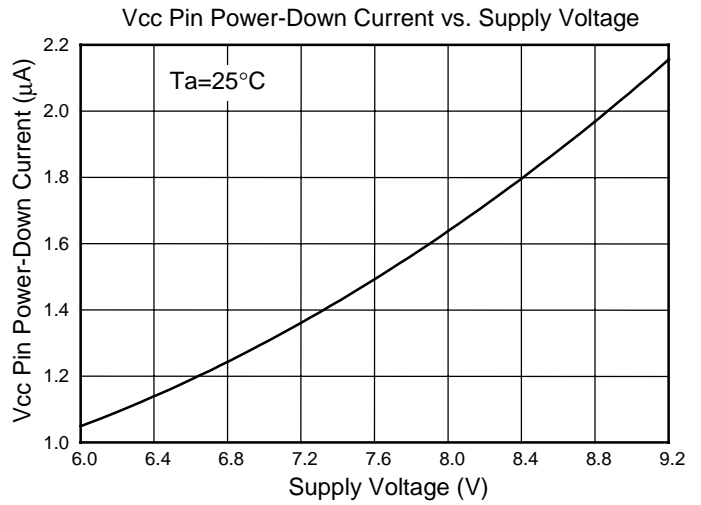
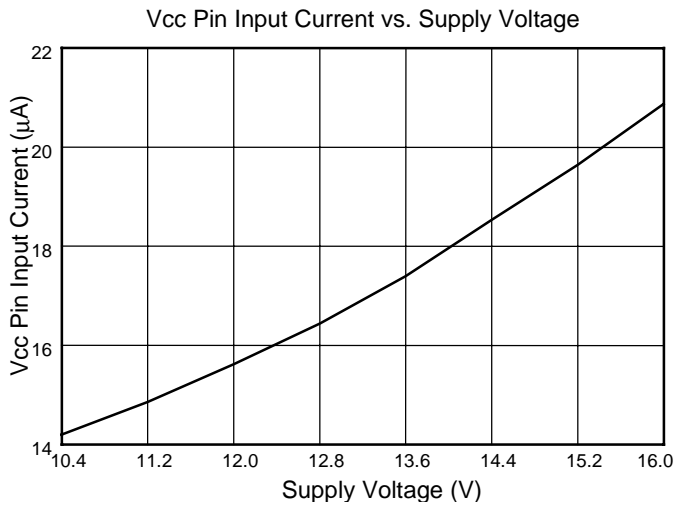



TYPICAL PERFORMANCE CHARACTERISTICS (CONTINUED)

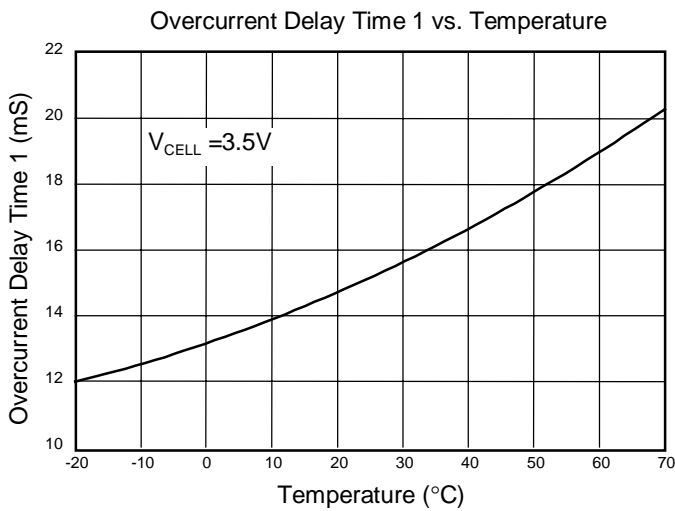
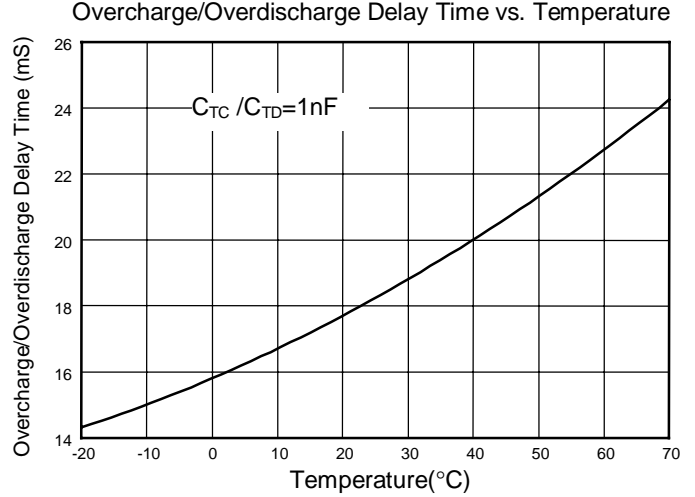
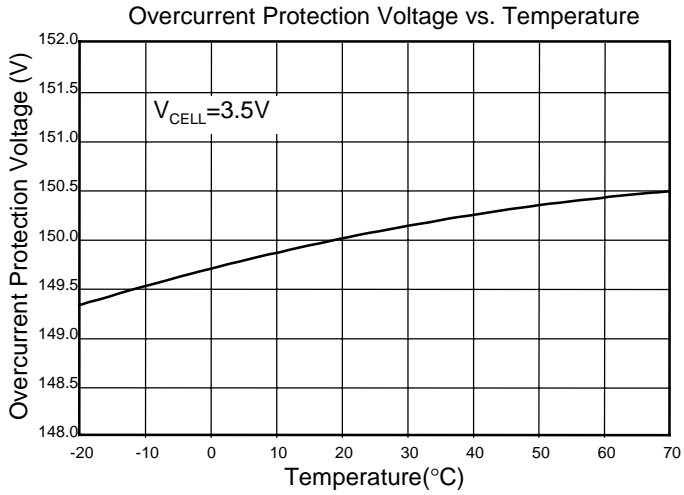



BLOCK DIAGRAM

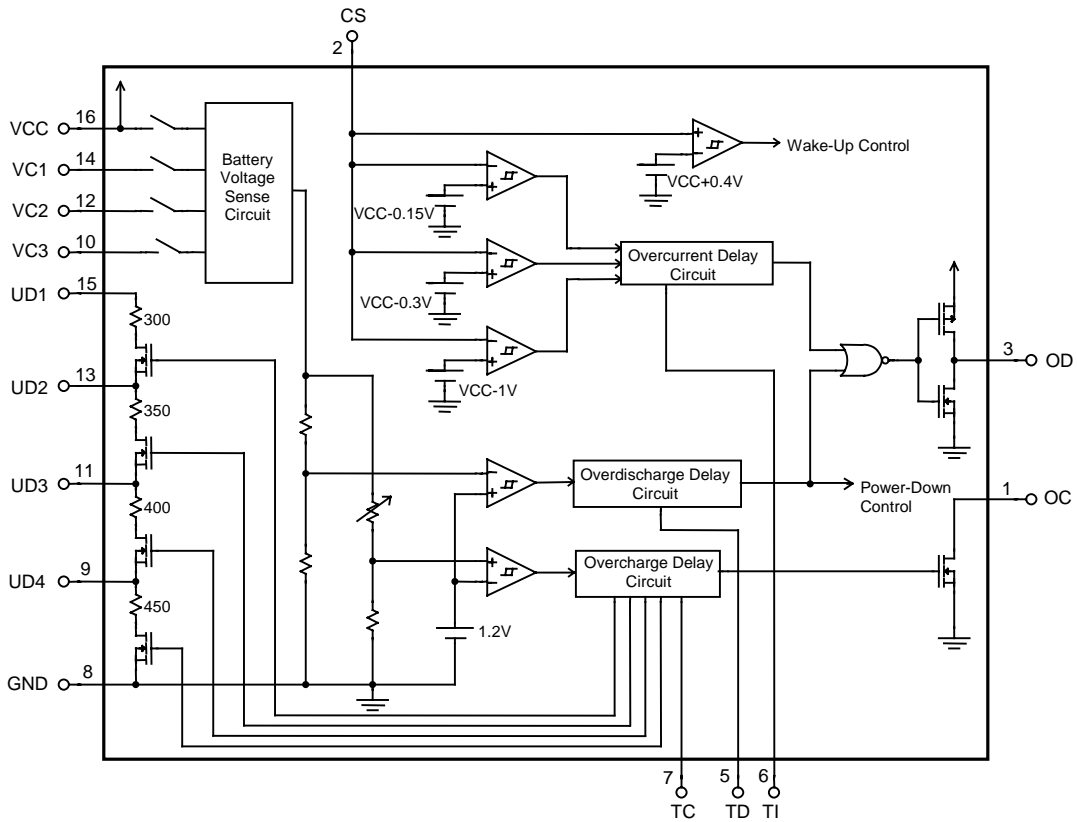

PIN DESCRIPTIONS

- PIN 1: NSL- Input pin for cell number selection. Connect this pin to VCC for three-cell application and to GND for four-cell application.
- PIN 2: OC- NMOS open drain output for control of the charge control MOSFET M2. When overcharge occurs, this pin sinks current to switch the external PNP Q1 on, and charging is inhibited by turning off the charge control MOSFET M2.
- PIN 3: CS- Input pin for current sensing. Using the drain-source voltage of the discharge control MOSFET M1 (voltage between VCC and CS), it senses discharge current during normal mode and detects whether charging current is present during power-down mode.
- PIN 4: OD - Output pin for control of discharge control MOSFET M1. When overdischarge occurs, this pin goes high to turn off the discharge control MOSFET M1 and discharging is inhibited.
- PIN 5: TD- Overdischarge delay time setting pin.
- PIN 6: TI - Overcurrent delay time setting pin.
- PIN 7: TC - Overcharge delay time setting pin.
- PIN 8: GND - Ground pin. This pin is to be connected to the negative terminal of the battery cell BAT4.
- PIN 9: UD4- This pin is to be connected to the positive terminal of the battery cell BAT4 for cell-balancing bleeding function under overcharge condition.
- PIN10: VC3- Input pin for battery BAT4 voltage sensing. This pin is to be connected to the positive terminal of the battery cell BAT4.
- PIN11: UD3 - This pin is to be connected to the positive terminal of the battery cell BAT3 for cell-balancing bleeding function under overcharge condition.
- PIN12: VC2 - Input pin for battery BAT3 voltage sensing. This pin is to be connected to the positive terminal of the battery cell BAT3.



positive terminal of the battery BAT1 for cell-balancing bleeding function under overcharge condition.

PIN13: UD2 - This pin is to be connected to the positive terminal of the battery cell BAT2 for cell-balancing bleeding function under overcharge condition.

PIN14: VC1 - Input pin for battery BAT2 voltage sensing. This pin is to be connected to the positive terminal of the battery cell BAT2.

PIN15: UD1 - This pin is to be connected to the

PIN16: VCC - Power supply pin and input for battery BAT1 voltage sensing. This pin is to be connected to the positive terminal of the battery cell BAT1.

APPLICATION INFORMATIONS

THE OPERATION

Initialization

On initial power-up, such as connecting the battery pack for the first time to the AIC1804, the AIC1804 enters the power-down mode. A charger must be applied to the AIC1804 circuit to enable the pack.

Overcharge Protection

When the voltage of either of the battery cells exceeds the overcharge protection voltage (V_{OCP}) beyond the overcharge delay time (T_{OC}) period, charging is inhibited by the turning-off of the charge control MOSFET M2. The overcharge delay time is set by the external capacitor C_{TC} . Inhibition of charging is immediately released when the voltage of the overcharged cell becomes lower than overcharge release voltage (V_{OCR} or $V_{OCP}-V_{HYS}$) through discharging.

Overdischarge Protection

When the voltage of either of the battery cells exceeds the overdischarge protection voltage (V_{ODP}) beyond the overdischarge delay time (T_{OD}) period, discharging is inhibited by the turning-off of the discharge control MOSFET M1. The overdischarge delay time is set by the external capacitor C_{TD} . Inhibition of discharging is immediately released when the voltage of the overdischarge cell becomes higher than the overdischarge release voltage (V_{ODR}) through charging.

Overcurrent Protection

In normal mode, the AIC1804 continuously monitors the discharge current by sensing the voltage of CS pin. If the voltage $V_{CC}-V_{CS}$ exceeds the overcurrent protection voltage (V_{OIP}) beyond the overcurrent delay time (T_{OI}) period, the overcurrent protection circuit operates and discharging is inhibited by the turning-off of the discharge control MOSFET M1. Discharging must be inhibited for at least 256mS after overcurrent takes place to avoid damage to external control MOSFETs due to rapidly switching transient between BATT+ and BATT- terminals. The overcurrent condition returns to normal mode when the load is

released and the impedance between the BATT+ and BATT- terminals is $20M\Omega$ or higher.

The AIC1804 is provided with the three overcurrent detection levels (0.15V, 0.3V and 1.0V) and the three overcurrent delay time (T_{OI1} , T_{OI2} and T_{OI3}) corresponding to each overcurrent detection level. T_{OI1} is set by the external capacitor C_{TI} . T_{OI2} and T_{OI3} default to 4mS and 300 μ s respectively, and can not be adjusted due to protection of external MOSFETs

Cell-Balancing Bleeding after Overcharge

When either of the battery cells is overcharged, the AIC1804 provides the cell-balancing bleeding function to discharge the overcharged cell at about 9mA until the voltage of the overcharged cell decreases to overcharge release voltage (V_{OCR} or $V_{OCP}-V_{HYS}$). Connecting UD1, UD2, UD3 and UD4 pins to the positive terminals of battery cells BAT1, BAT2, BAT3 and BAT4 accomplish this function, respectively. Inserting resistors along UD2 pin to BAT2 positive terminal path and UD4 pin to BAT4 positive terminal path can decrease the bleeding current.

Power-Down after Overdischarge

When overdischarge occurs, the AIC1804 will go into power-down mode, turning off all the timing generation and detection circuitry to reduce the quiescent current to about 2.2 μ A ($V_{CC}=9.2V$). In the unusual case where one battery cell is overdischarged while another one under overcharge condition, the AIC1804 will turn off all the detection circuitry except the overcharge detection circuit for the cell under overcharge condition.

Charge Detection after Overdischarge

When overdischarge occurs, the discharge control MOSFET M1 turns off and discharging is inhibited. However, charging is still permitted through the parasitic diode of M1. Once the charger is connected to the battery pack, the AIC1804 immediately turns on all the timing generation and detection circuitry and goes into normal mode. Charging is determined to be



in progress if the CS pin voltage is higher than $V_{CC} + 0.4V$ (charge detection threshold voltage V_{CH}).

● DESIGN GUIDE

Cell Number Selection

The user must configure the AIC1804 for three or four series cells application. For three-cell application, NSL pin should be connected directly to VCC pin. For four-cell application, NSL pin should be connected directly to GND pin.

Number of Series Cells	NSL Pin
3-cell	Connected to VCC
4-cell	Connected to GND

The protection circuit for three-cell lithium-ion battery pack is shown in application examples Fig. 1.

Setting the Overcharge and Overdischarge Delay Time

The overcharge delay time is set by the external capacitor C_{TC} and the overdischarge delay time is set by the external capacitor C_{TD} . The relationship between capacitance of the external capacitors and delay time is tabulated as below.

$C_{TC}, C_{TD}(F)$	1n	5n	10n	22n	33n
$T_{OC}, T_{OD}(S)$	21m	52m	132m	253m	347m

$C_{TC}, C_{TD}(F)$	47n	68n	82n	100n
$T_{OC}, T_{OD}(S)$	617m	748m	1004m	1630m

The delay time can also be approximately calculated by the following equations (if $C_{TC}, C_{TD} \leq 82nF$):

$$T_{OC}(mS) = 11.8 \times C_{TC}(nF)$$

$$T_{OD}(mS) = 11.8 \times C_{TD}(nF)$$

Setting the Overcurrent Delay Time 1

The overcurrent delay time 1 (T_{O11}) at $0.15V < V_{CC} - V_{CS} < 0.3V$ is set by the external capacitor C_{TI} , while the overcurrent delay time 2 and 3 (T_{O12} and T_{O13}) is fixed by IC internal circuit. The relationship between capacitance of the external capacitor and delay time is tabulated as below.

$C_{TI}(F)$	1n	2.2n	3.3n	5n	6.8n	10n
$T_{O1}(S)$	4.8m	15.0m	18.8m	23.6m	31.0m	61.8m

Selection of External Control MOSFETs

Because the overcurrent protection voltage is preset, the threshold current for overcurrent detection is determined by the turn-on resistance of the discharge control MOSFET M1. The turn-on resistance of the external control MOSFETs can be determined by the equation: $R_{ON} = V_{OIP} / I_T$ (I_T is the overcurrent threshold current). For example, if the overcurrent threshold current I_T is designed to be 5A, the turn-on resistance of the external control MOSFETs must be $30M\Omega$. Users should be aware that turn-on resistance of the MOSFET changes with temperature variation due to heat dissipation. It changes with the voltage between gate and source as well. (Turn-on resistance of a MOSFET increases as the voltage between gate and source decreases). Once the turn-on resistance of the external MOSFET changes, the overcurrent threshold current will change accordingly.

Suppressing the Ripple and Disturbance from Charger

To suppress the ripple and disturbance from charger, connecting R1 to R4 and C1 to C4 is recommended. Larger R1 will cause larger error of battery sense voltage. Resistance of 10Ω is recommended.

Controlling the Charge Control MOSFET

R5, R6, R7 and NPN transistor Q1 are used to switch the charge control MOSFET M2. If overcharge does not occur, no current flows into OC pin and Q1 is turned off, then M2 is turned on. When overcharge occurs, current flows into OC pin and Q1 is turned on, which turns off M2 in turn.

Protection at CS Pin

R8 is used for protection of IC when charger is connected in reverse. The charge detection function after overdischarge is possibly disabled by larger value of R8. Resistance of $1K\Omega$ is recommended.



APPLICATION EXAMPLES

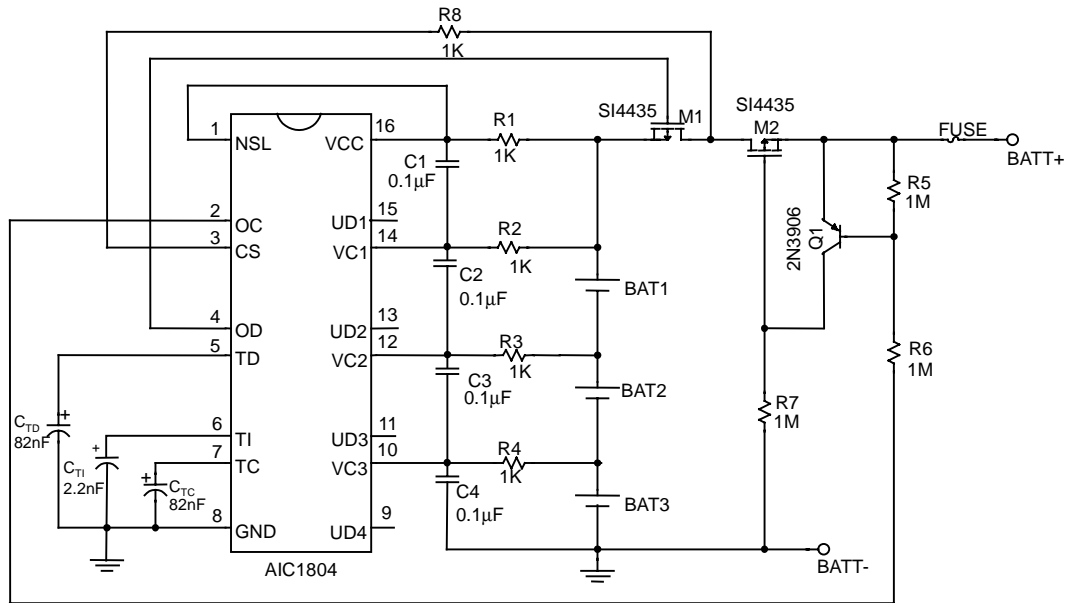
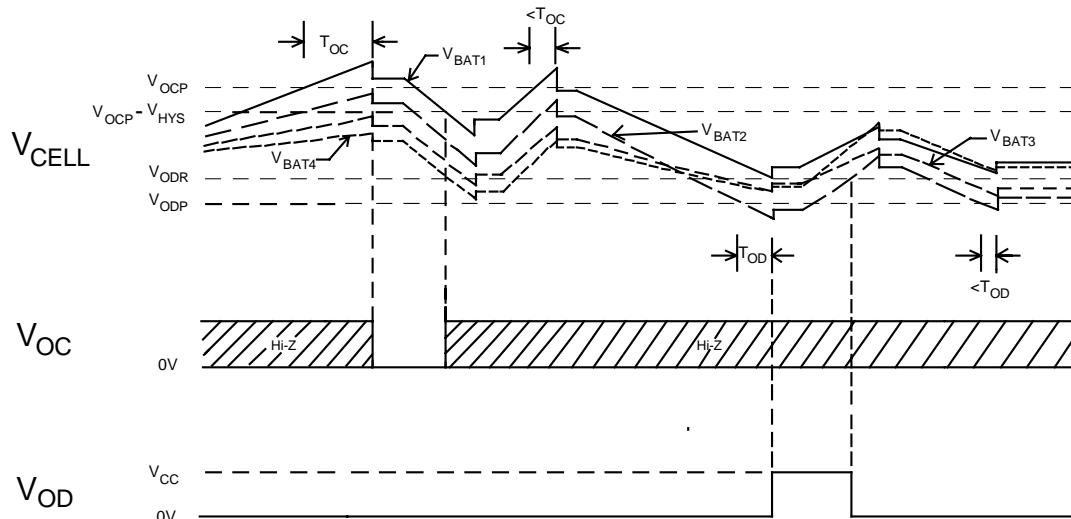

Fig. 1 Protection Circuit for Three-Cell Lithium-Ion Battery Pack

TIMING DIAGRAM

- Overcharge and Overdischarge Protection ($V_{CS}=V_{CC}$)





● Overcurrent Protection ($V_{CELL}=3.5V$)

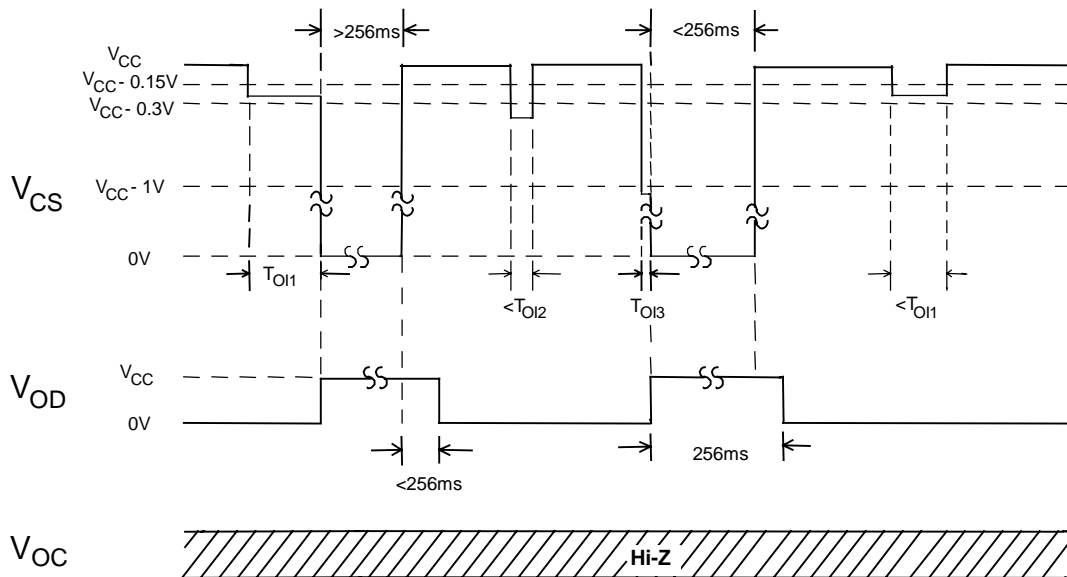

■ PHYSICAL DIMENSIONS

● 16 LEAD PLASTIC SO

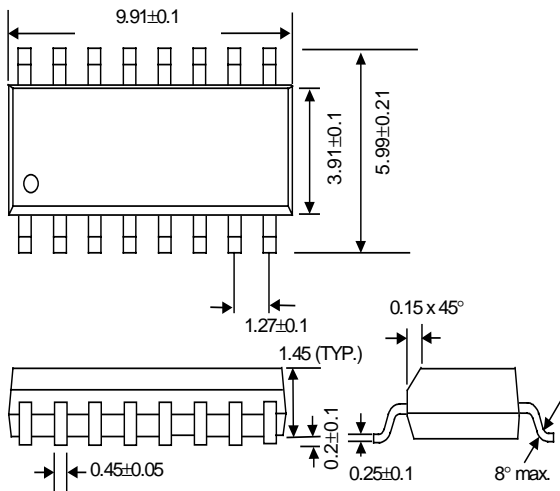

UNIT: mm