



IN-PLUG® SERIES

Gateway to Low Cost, High Efficiency SMPS Integration

UNIVERSAL HIGH BRIGHTNESS WHITE LED CONTROLLER

HIGH EFFICIENCY IPS401 WHITE LED CONTROLLER WITH POWER FACTOR CORRECTION AND LOW SWITCHING LOSSES/LOW EMI CAPABILITIES

FEATURES

- Unique self oscillating and optimum continuous mode controller able to drive hundreds of White LED diodes, typically 120 to 1,000 from an AC source, or 10 to several hundreds from a DC source
- 12VDC to 265V AC sources and beyond
- Constant current LED operation for maximum LED brightness, maximum life and reliability
- Built-in PFC with low harmonic distortion and Power Factor Correction
- High-efficiency > 95% to save power and reduce heat dissipation
- Self oscillating with jitter and optimum continuous current mode to reduce harmonics, improve EMI and efficiency
- LED current control and overvoltage protection
- LED intensity is application programmable or dimmable
- Minimum design cycle with low component count solutions
- No need for electrolytic capacitors in many applications

WHITE LED CONTROLLER

IPS401 Simple, efficient and easy to use! Minimum external component count White LED controller with outstanding performance at any line voltage and any load with built-in PFC capabilities.

Available in 8-pin DIL & SOIC packages



IPS-DK 401 controller board

IPS401

The IPS401 is the world's first White LED controller capable of driving one or more strings of up to 120 LEDs in series with high efficiency and power factor correction. The IPS401 is the forerunner of a series of ICs which will provide a means of implementing high efficiency, long life, and reliable lighting systems for public buildings, industry, homes, transportation systems and secure installations. It is also the ultimate solution for RGB backlighting, flat panel display backlighting and automotive long life lighting and energy saving requirements. Safety features of the IPS401 include over voltage and over current protection.

A host of novel features such as self-oscillating and continuous mode of operation, PFC capability together with exceptionally low power dissipation make the IPS401 a truly breakthrough product which will establish standards for future "green" lighting technology.

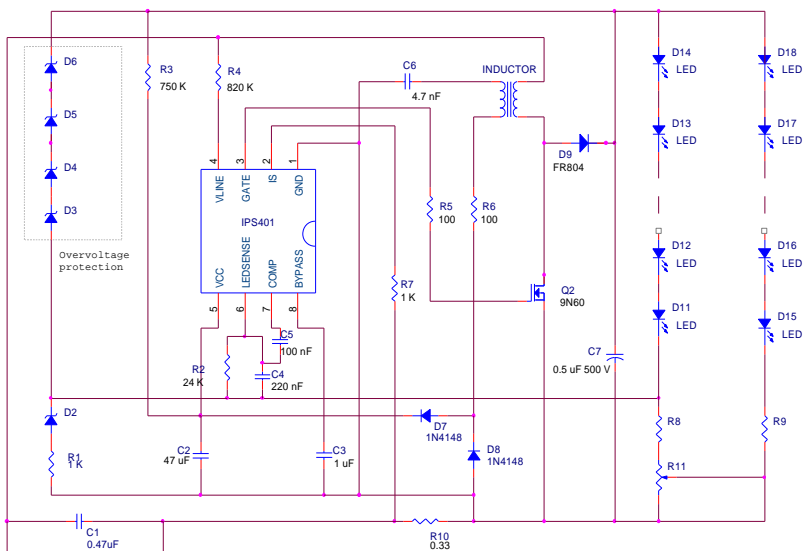

TYPICAL ARCHITECTURE for AC input 85-265VAC

Note: This schematic is easily adaptable to less than 60 LEDs at 120VAC or less than 120 LEDs at 220VAC and 85-265VAC applications. Please consult IN-PLUG® support.

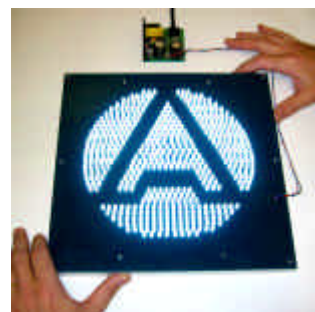

AAI's logo includes 4 strings of 125 White LEDs

