



High-Efficiency, Step-Down DC/DC Controller**■ FEATURES**

- High Efficiency (up to 95%).
- Low Quiescent Current at 90 μ A.
- Pulse-Skipping and Pulse-Frequency Modulation.
- Inputs-Uncommitted Current Sense Comparator.
- Duty Cycle Adjustable.
- 90KHz to 280KHz Oscillator Frequency.
- Power-Saving Shutdown Mode (8 μ A Typical).
- Push-Pull Driver Output.

■ APPLICATIONS

- LCD Monitors
- Notebook Computers
- Step-Down DC/DC Controller Module.
- Constant Current Source for Battery Chargers.

■ DESCRIPTION

The AIC1578 is a high performance step-down DC/DC controller, designed to drive an external P-channel MOSFET to generate programmable output voltages. Two main schemes of Pulse-Skipping and Pulse-Frequency Modulation are employed to maintain low quiescent current and high conversion efficiency under wide ranges of input voltage and loading condition. The AIC1578 delivers 10mA to 2A of output current with 87%~93% efficiency at $V_{IN}=9V$, $V_{OUT}=5V$ condition. A current sense comparator with both inverting and non-inverting input uncommitted is included to provide the crucial function of either current limit protection or constant output current control. When the AIC1578 is used in a high-side current sensing step-down constant current source, the efficiency is typically greater than 90%. Duty cycle can be adjusted to greater than 90% by connecting a resistor from DUTY pin to V_{IN} . Quiescent current is about 90 μ A and can be reduced to 8 μ A in shutdown mode. Switching frequency being in around 90KHz to 280KHz range, small size switching components are ideal for battery powered portable equipment.



TYPICAL APPLICATION CIRCUIT

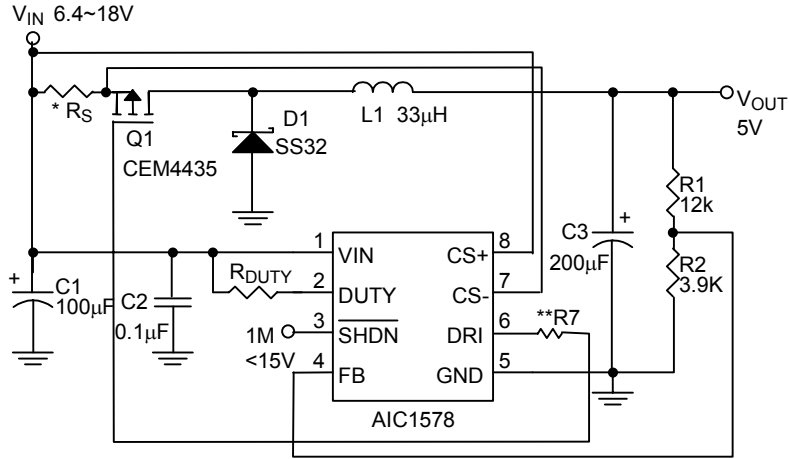

* R_S should not be omitted so that inrush current won't be too high.

$$I_P = I_{O,MAX} + \frac{V_O(V_{IN} - V_O)}{2V_{IN} \times f_S \times L}$$

$$R_S = \frac{V_{TH}}{I_P} = \frac{50mV}{I_P} = \frac{0.1V_{IN}f_S L}{2V_{IN}f_S L I_{O,MAX} + V_{IN}V_O - V_O^2}$$

- V_{IN} : Input voltage
- V_{OUT} : Output voltage
- f_S : Working frequency
- L : Inductor value
- $I_{O,MAX}$: Maximum Output current
- V_{TH} : Current Limit Sense Threshold
- ** $V_{IN} > 15V$, $R7 = 15\Omega$
- $V_{IN} \leq 15V$, $R7 = 0\Omega$

DC/DC Buck Converter

ORDERING INFORMATION

AIC1578XXXX

- PACKING TYPE
TR: TAPE & REEL
TB: TUBE
- PACKAGING TYPE
S: SMALL OUTLINE
N: PLASTIC DIP
- C: Commercial
P: Lead Free Commercial

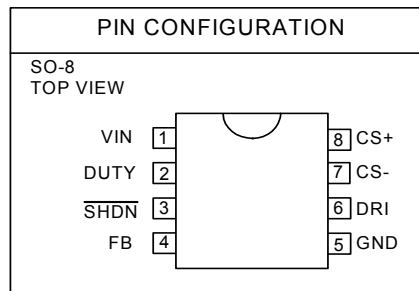

- Example: AIC1578CSTR
→ in SO-8 Package & Taping & Reel Packing Type
(CN is not available in TR packing)
- AIC1578PSTR
→ in SO-8 Lead Free Package & Taping & Reel Packing Type



■ ABSOLUTE MAXIMUM RATINGS

VIN Supply Voltage.....	20V
DUTY Voltage.....	20V
SHDN Voltage.....	15V
Operating Temperature Range.....	-40°C ~ 85°C
Junction Temperature Range.....	125°C
Storage Temperature Range.....	-65°C ~ 150°C
Lead Temperature (Soldering 10 Sec).....	260°C

Absolute Maximum Ratings are those values beyond which the life of a device may be Impaired.

■ TEST CIRCUIT

Refer to TYPICAL APPLICATION CIRCUIT.

■ ELECTRICAL CHARACTERISTICS

(VIN= 13V, TA=25°C, unless otherwise specified.) (Note 1)

PARAMETERS	CONDITIONS	MIN.	TYP.	MAX.	UNIT
Operation Voltage		4		20	V
Quiescent Current	VFB = 1.5V		90	160	μA
Shutdown Mode Current	VSHDN = 0V		8	20	μA
Internal Reference Voltage		1.195	1.22	1.245	V
Driver Sinking "ON Resistance"			16		Ω
Driver Sourcing "ON Resistance"			11		Ω
Current Limit Sense Threshold	VCS+ = 13V	50	70	90	mV
Shutdown Threshold		0.6	0.9	1.2	V
SHDN Pin Leakage Current	VSHDN < 15V			1	μA
Duty Cycle	VDUTY = VIN	70	75	80	%
Oscillator Frequency	VDUTY = VIN		225		KHz

Note 1 : Specifications are production tested at TA = 25°C. Specifications over the -40°C to 85°C operating Temperature range are assured by design, characterization and correlation with Statistical Quality Controls (SQC).



TYPICAL PERFORMANCE CHARACTERISTICS

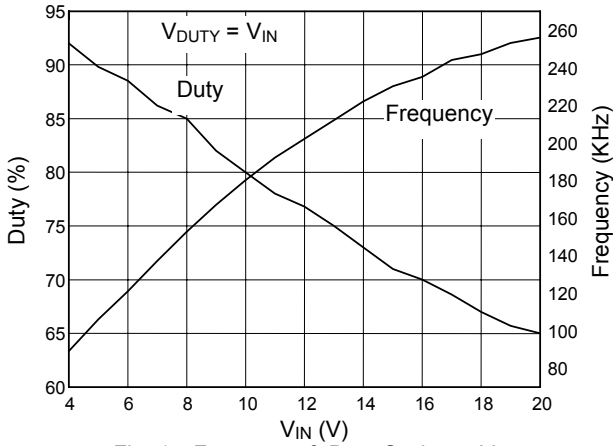

Fig. 1 Frequency & Duty Cycle vs. V_{IN}

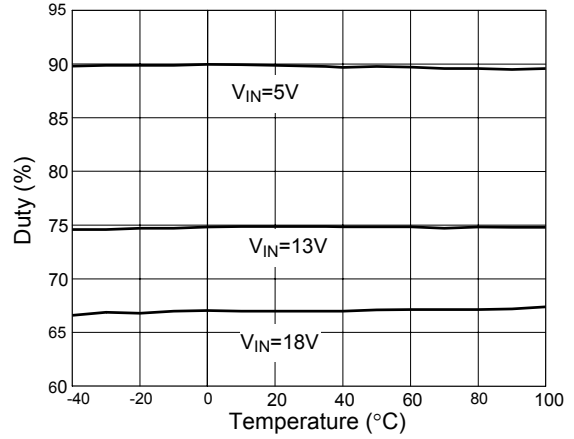

Fig. 2 Duty Cycle vs. Temperature

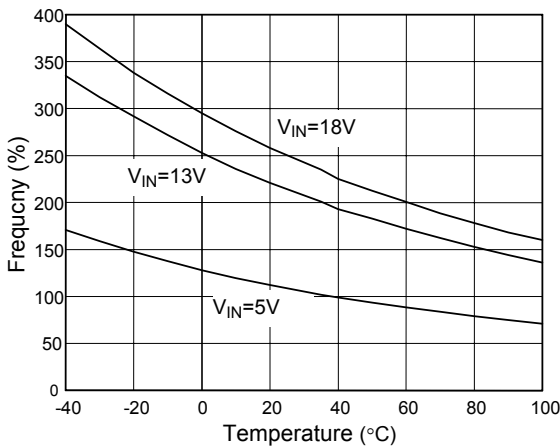

Fig. 3 Frequency vs. Temperature

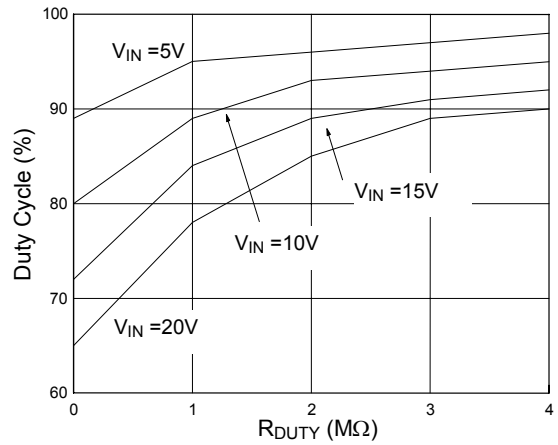

Fig. 4 Duty Cycle vs. R_{DUTY}

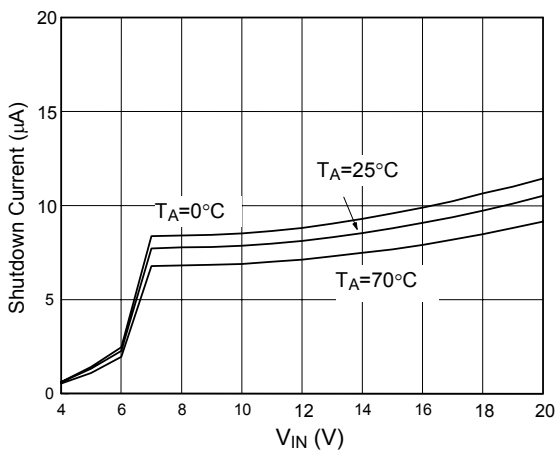

Fig. 5 Shutdown vs. V_{IN}

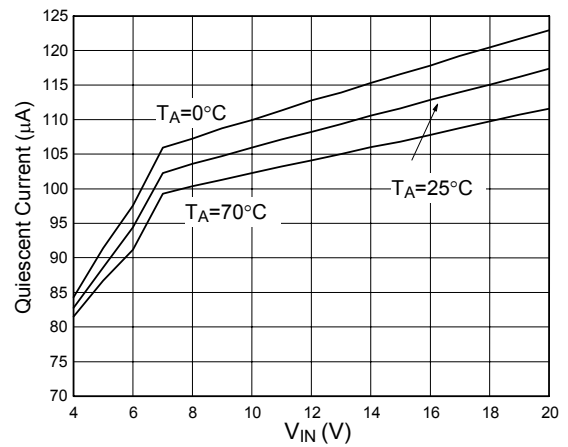
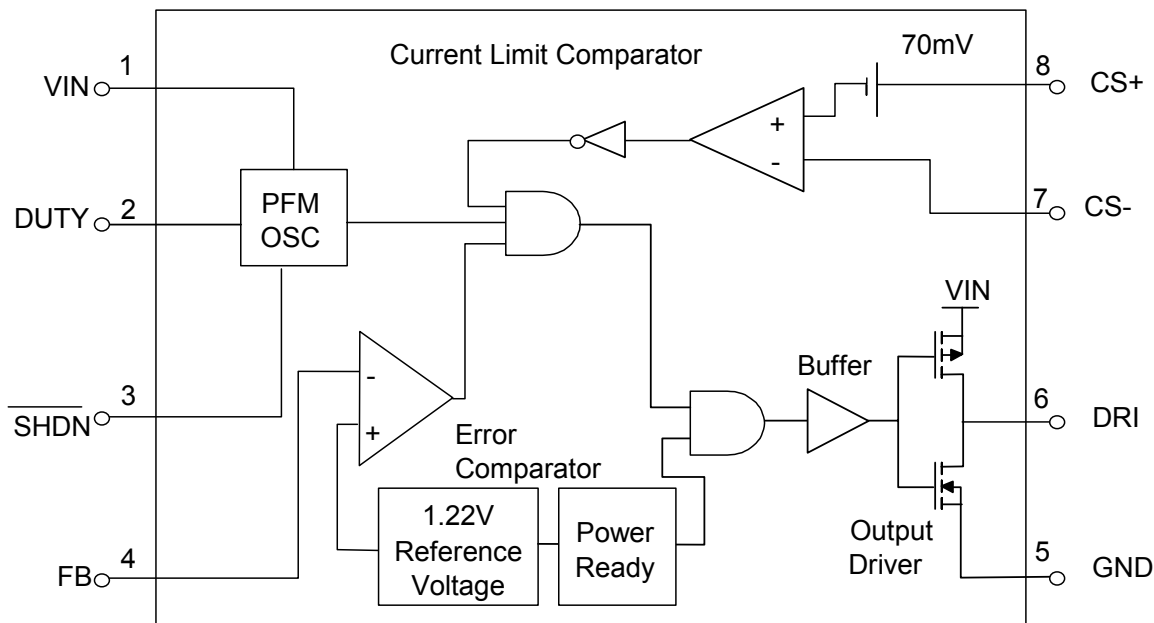

Fig. 6 Quiescent Current vs. V_{IN}



■ BLOCK DIAGRAM



■ PIN DESCRIPTIONS

- PIN 1: VIN - Input supply voltage, ranged from 4V to 18V is recommended.
- PIN 2: DUTY- Duty cycle adjustment pin. To be tied to the VIN pin directly or through a resistor R_{DUTY} to adjust oscillator duty cycle. R_{DUTY} must be over $1M\Omega$ if $V_{IN}=20V$. See TYPICAL PERFORMANCE CHARACTERISTICS.
- PIN 3: \overline{SHDN} - Logical input to shutdown the chip:
 $V_{\overline{SHDN}}$ = High for normal operation.
 $V_{\overline{SHDN}}$ = Low for shutdown.
 This pin should not be floating or be forced to over 15V. In shutdown mode DRI pins is at high level.
- PIN 4: FB - Feedback comparator input, to compare the feedback voltage with the internal reference

voltage. Connecting a resistor R1 to converter output node and a resistor R2 to ground yields the output voltage:

$$V_{OUT}=1.22 \times (R1+R2)/ R2$$

- PIN 5: GND - Power ground.
- PIN 6: DRI - Push-pull driver output to drive an external P-channel MOSFET or PNP transistor. When driving a PNP bipolar transistor, a base resistor and a capacitor to the base of PNP are recommended.
- PIN 7: CS- - Current sense comparator inverting input. This pin voltage should go over 2V but not to exceed V_{IN} voltage.
- PIN 8: CS+ - Current sense comparator non-inverting input. This pin voltage should go over 2V but not to exceed V_{IN} voltage.



APPLICATION INFORMATION

Short Circuit Protection Design

1. As we know, Short Circuit Protection (abbreviated as SCP) does not always exist in the DC-DC converter circuit. The fact is usually the DC-DC converter provides the circuits attached to VOUT with low power or low voltage. Sometimes it has less concern about safety. And its probability of short-circuit is quite low. That gives users reasons to ignore the use of SCP circuit. However, we would still like to point out the importance of the protection. With SCP, the system will be well protected in any situation. Two SCP circuits are introduced as follows for your reference.
2. Design1: shown as Fig. 10.
Method: Add a fast fuse to VOUT.

Fuse select guide: Fuses, which can take the start up current, and break down fast on unexpected current.
Note: Replacement of fuse is needed after short circuit.

3. Design 2: shown as Fig. 11.
Method: Add a SCP circuit
Note: 1. The time constant, which is directly related to R1 and C1, has a serious effect on the circuit.
2. Circuit can be recovered by removing the short circuit event from the system.
3. The condition for applying this design is $V_{OUT} \geq 3V$.

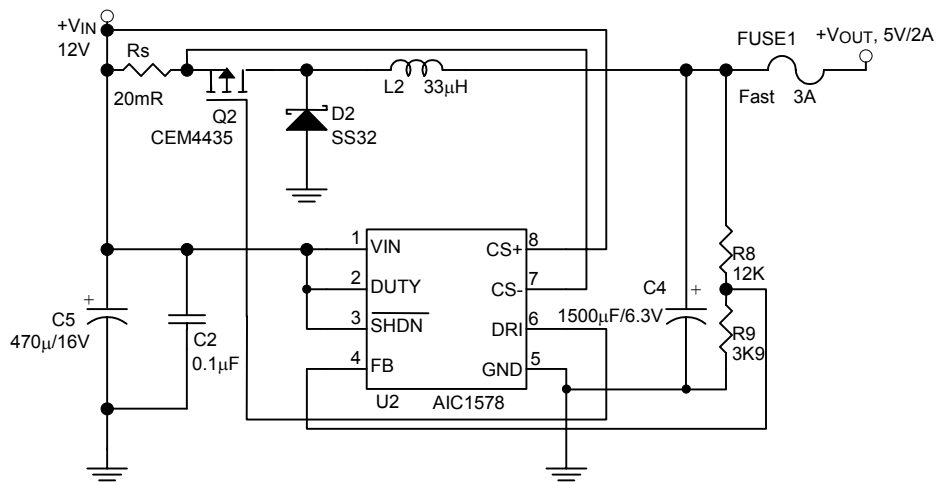

Fig 10. Add a Fast Fuse Solution



■ APPLICATION INFORMATION (Continued)

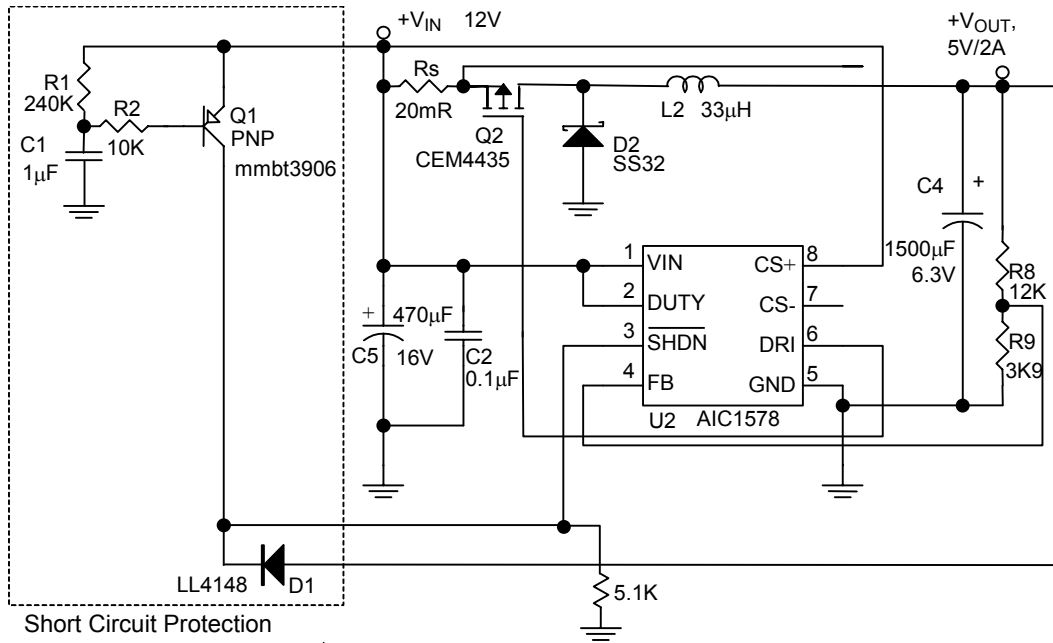

Fig 11. Add A Short Circuit Protection Circuit Solution



APPLICATION EXAMPLES

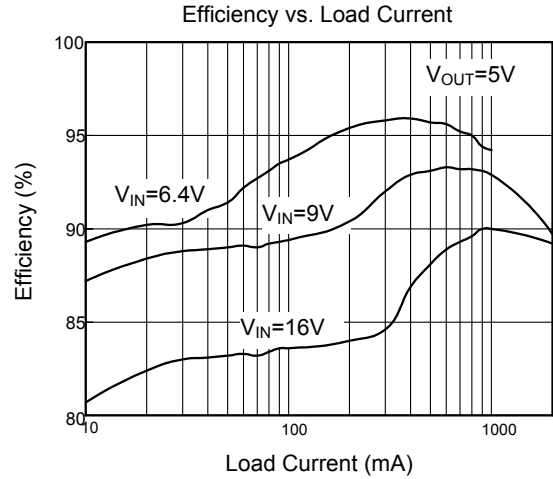
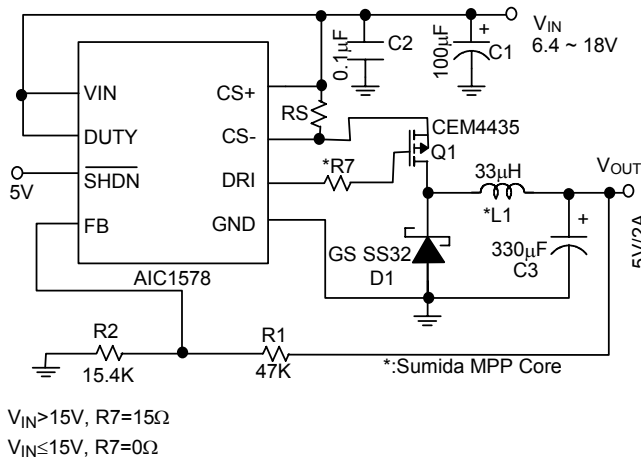

Fig. 7 5V Step-Down Converter

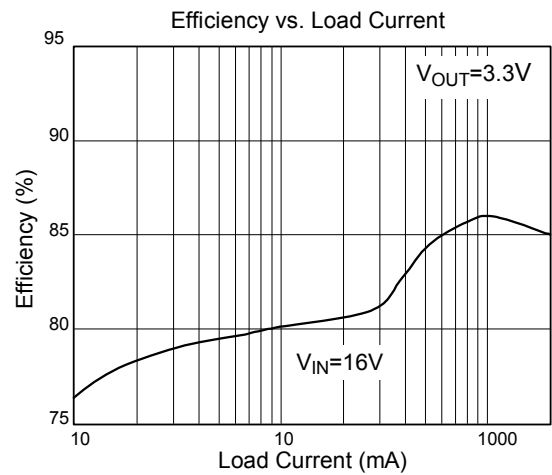
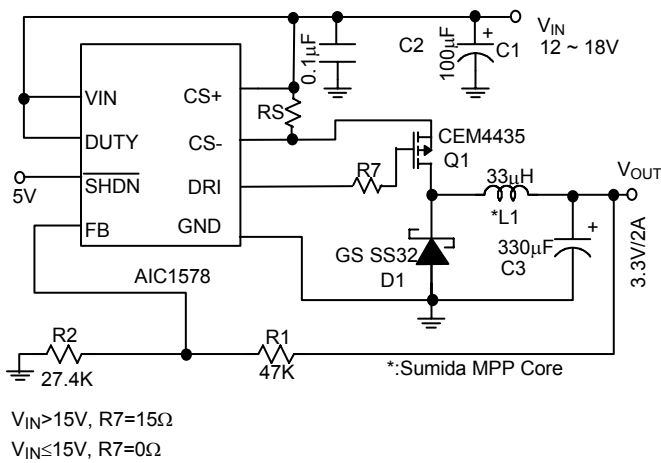
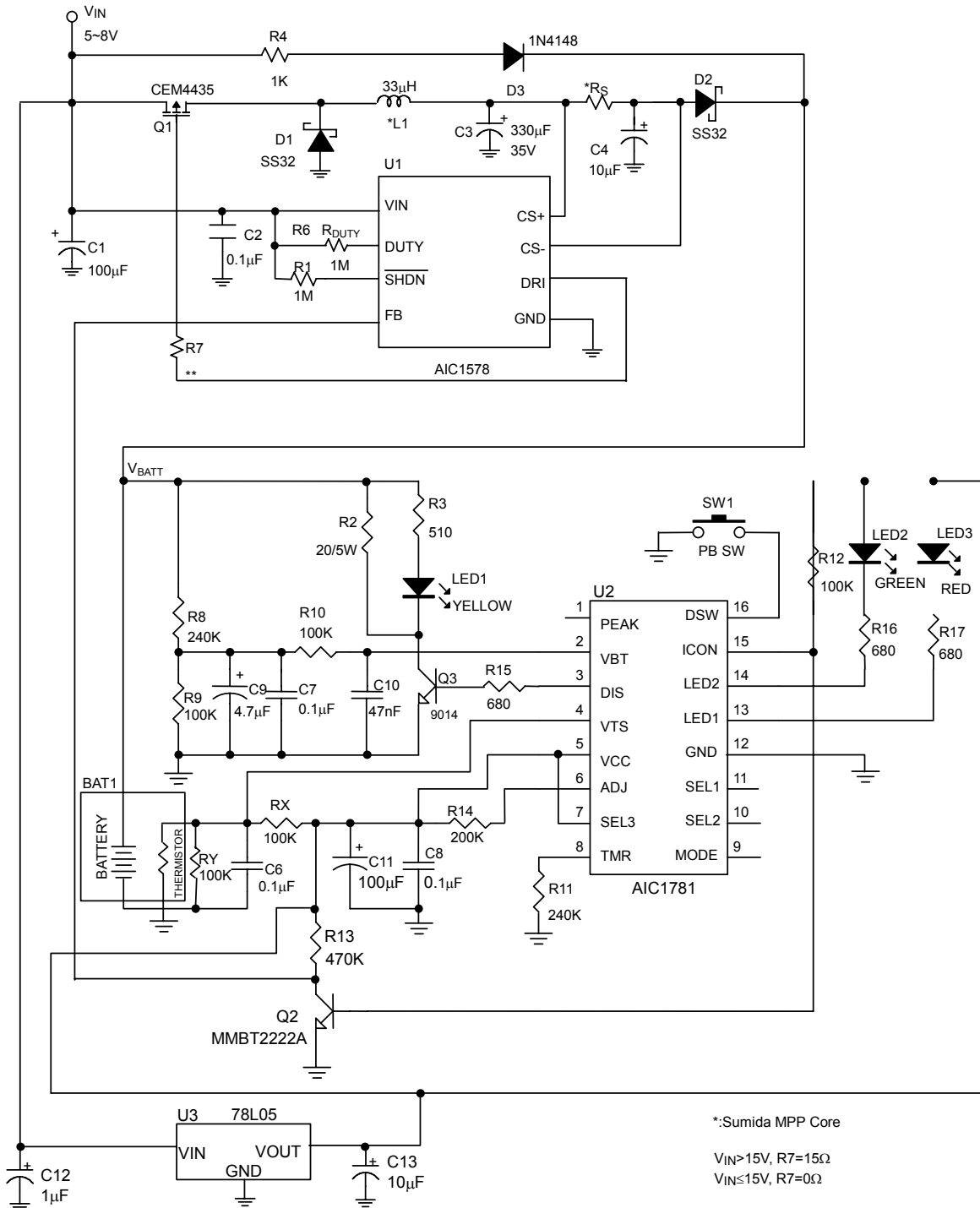

Fig. 8 3.3V Step-Down Converter



APPLICATION EXAMPLES (Continued)



NOTE: $R_S = 0.1\Omega$, charge current = $0.5A \pm 10\%$, $V_{IN} > V_{BATT} + 3.5V$
 $R_S = 0.05\Omega$, charge current = $1A \pm 10\%$, $V_{IN} > V_{BATT} + 4V$
 $R_S = 0.033\Omega$, charge current = $1.5A \pm 10\%$, $V_{IN} > V_{BATT} + 4.5V$
 Efficiency > 90%, measured at CS- node
 3~5 NiMH/NiCd Cells

Fig. 9 Battery Charge Circuit with High-Side Current Sensing Constant Current Source



■ PHYSICAL DIMENSIONS (unit: mm)

● 8 LEAD PLASTIC SO (CS) (PS)

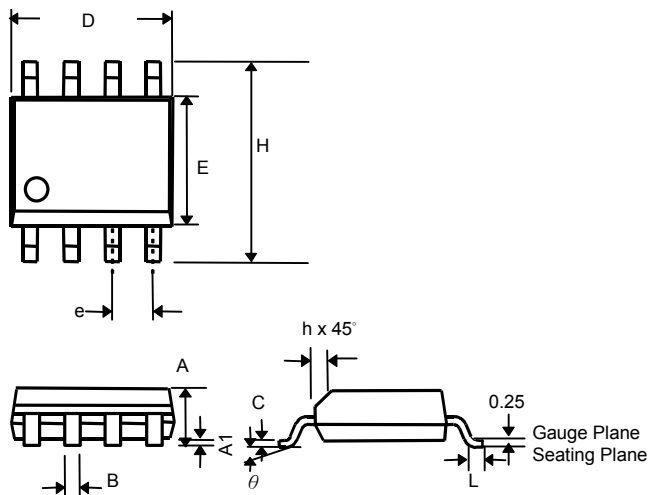

SYMBOL	MIN	MAX
A	1.35	1.75
A1	0.10	0.25
B	0.33	0.51
C	0.19	0.25
D	4.80	5.00
E	3.80	4.00
e	1.27BSC	
H	5.80	6.20
h	0.25	0.50
L	0.40	1.27
θ	0°	8°

● 8 LEAD PLASTIC DIP (CN) (PN)

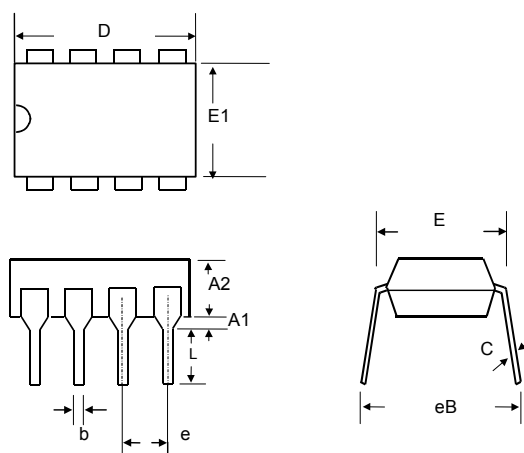

SYMBOL	MIN	MAX
A	—	5.33
A1	0.38	—
A2	2.92	4.95
b	0.36	0.56
b2	1.14	1.78
c	0.20	0.35
D	9.01	10.16
D1	0.13	—
E	7.62	8.26
E1	6.10	7.11
e	2.54 BSC	
eA	7.62 BSC	
eB	—	10.92
L	2.92	3.81



Note:

Information provided by AIC is believed to be accurate and reliable. However, we cannot assume responsibility for use of any circuitry other than circuitry entirely embodied in an AIC product; nor for any infringement of patents or other rights of third parties that may result from its use. We reserve the right to change the circuitry and specifications without notice.

Life Support Policy: AIC does not authorize any AIC product for use in life support devices and/or systems. Life support devices or systems are devices or systems which, (i) are intended for surgical implant into the body or (ii) support or sustain life, and whose failure to perform, when properly used in accordance with instructions for use provided in the labeling, can be reasonably expected to result in a significant injury to the user.