

UL 498A

ISBN 0-7629-0483-6

Current Taps and Adapters

*UL COPYRIGHTED MATERIAL –
NOT AUTHORIZED FOR FURTHER REPRODUCTION OR
DISTRIBUTION WITHOUT PERMISSION FROM UL*

*UL COPYRIGHTED MATERIAL –
NOT AUTHORIZED FOR FURTHER REPRODUCTION OR
DISTRIBUTION WITHOUT PERMISSION FROM UL*

Underwriters Laboratories Inc. (UL)
333 Pfingsten Road
Northbrook, IL 60062-2096

UL Standard for Safety for Current Taps and Adapters, UL 498A

First Edition, Dated December 17, 1999

Revisions: This Standard contains revisions through and including April 30, 2003.

SUMMARY OF TOPICS

Revision of Noninterchangeability Obstruction Requirements

UL Standards for Safety are developed and maintained in the Standard Generalized Markup Language (SGML). SGML -- an international standard (ISO 8879-1986) -- is a descriptive markup language that describes a document's structure and purpose, rather than its physical appearance on a page. Due to formatting differences resulting from the use of UL's new electronic publishing system, please note that additional pages (on which no requirements have been changed) may be included in revision pages due to relocation of existing text and reformatting of the Standard.

Text that has been changed in any manner is marked with a vertical line in the margin. Changes in requirements are marked with a vertical line in the margin and are followed by an effective date note indicating the date of publication or the date on which the changed requirement becomes effective.

The following table lists the future effective dates with the corresponding item.

Future Effective Dates	References
April 1, 2009	Section 37, Sub-sections 7.8, 7.9, 8.3, 15.6, 15.7, Paragraphs 7.1.1, 7.6.1, 8.1.1, 8.2.1, 8.2.2, 8.2.3, 8.2.4, 9.1, 9.2, 9.3, 9.4, 9.5, 9.6, 9.7, 9.8, 9.9, 9.10, 9.11, 9.12, 9.14, 9.15, 9.16, 11.3.1, 11.4.1, 30.14, 31.8, 33.4, Tables 9.1, 18.1, Figures 9.1, 11.3

The new requirements are substantially in accordance with UL's Bulletin(s) on this subject dated December 16, 2002. The bulletin(s) is now obsolete and may be discarded.

The revisions dated April 30, 2003 include a reprinted title page (page1) for this Standard.

As indicated on the title page (page 1), this UL Standard for Safety is an American National Standard. Attention is directed to the note on the title page of this Standard outlining the procedures to be followed to retain the approved text of this ANSI/UL Standard.

The master for this Standard at UL's Northbrook Office is the official document insofar as it relates to a UL service and the compliance of a product with respect to the requirements for that product and service, or if there are questions regarding the accuracy of this Standard.

UL's Standards for Safety are copyrighted by UL. Neither a printed copy of a Standard, nor the distribution diskette for a Standard-on-Diskette and the file for the Standard on the distribution diskette should be altered in any way. All of UL's Standards and all copyrights, ownerships, and rights regarding those Standards shall remain the sole and exclusive property of UL.

**UL COPYRIGHTED MATERIAL –
NOT AUTHORIZED FOR FURTHER REPRODUCTION OR
DISTRIBUTION WITHOUT PERMISSION FROM UL**

All rights reserved. No part of this publication may be reproduced, stored in a retrieval system, or transmitted in any form by any means, electronic, mechanical photocopying, recording, or otherwise without prior permission of UL.

Revisions of UL Standards for Safety are issued from time to time. A UL Standard for Safety is current only if it incorporates the most recently adopted revisions.

UL provides this Standard "as is" without warranty of any kind, either expressed or implied, including but not limited to, the implied warranties of merchantability or fitness for any purpose.

In no event will UL be liable for any special, incidental, consequential, indirect or similar damages, including loss of profits, lost savings, loss of data, or any other damages arising out of the use of or the inability to use this Standard, even if UL or an authorized UL representative has been advised of the possibility of such damage. In no event shall UL's liability for any damage ever exceed the price paid for this Standard, regardless of the form of the claim.

UL will attempt to answer support requests concerning electronic versions of its Standards. However, this support service is offered on a reasonable efforts basis only, and UL may not be able to resolve every support request. UL supports the electronic versions of its Standards only if they are used under the conditions and operating systems for which it is intended. UL's support policies may change from time-to-time without notification.

UL reserves the right to change the format, presentation, file types and formats, delivery methods and formats, and the like of both its printed and electronic Standards without prior notice.

Purchasers of the electronic versions of UL's Standards for Safety agree to defend, indemnify, and hold UL harmless from and against any loss, expense, liability, damage, claim, or judgement (including reasonable attorney's fees) resulting from any error or deviation introduced while purchaser is storing an electronic Standard on the purchaser's computer system.

If a single-user version electronic Standard was purchased, one copy of this Standard may be stored on the hard disk of a single personal computer, or on a single LAN file-server or the permanent storage device of a multiple-user computer in such a manner that this Standard may only be accessed by one user at a time and for which there is no possibility of multiple concurrent access.

If a multiple-user version electronic Standard was purchased, one copy of the Standard may be stored on a single LAN file-server, or on the permanent storage device of a multiple-user computer, or on an Intranet server. The number of concurrent users shall not exceed the number of users authorized.

Electronic Standards are intended for on-line use, such as for viewing the requirements of a Standard, conducting a word search, and the like. Only one copy of the Standard may be printed from each single-user version of an electronic Standard. Only one copy of the Standard may be printed for each authorized user of a multiple-user version of an electronic Standard. Because of differences in the computer/software/printer setup used by UL and those of electronic Standards purchasers, the printed copy obtained by a purchaser may not look exactly like the on-line screen view or the printed Standard.

An employee of an organization purchasing a UL Standard can make a copy of the page or pages being viewed for their own fair and/or practical internal use.

The requirements in this Standard are now in effect, except for those paragraphs, sections, tables, figures, and/or other elements of the Standard having future effective dates as indicated in the note following the affected item. The prior text for requirements that have been revised and that have a future effective date are located after the Standard, and are preceded by a "SUPERSEDED REQUIREMENTS" notice.

UL COPYRIGHTED MATERIAL –
NOT AUTHORIZED FOR FURTHER REPRODUCTION OR
DISTRIBUTION WITHOUT PERMISSION FROM UL

New product submittals made prior to a specified future effective date will be judged under all of the requirements in this Standard including those requirements with a specified future effective date, unless the applicant specifically requests that the product be judged under the current requirements. However, if the applicant elects this option, it should be noted that compliance with all the requirements in this Standard will be required as a condition of continued Listing, Recognition, and Follow-Up Services after the effective date, and understanding of this should be signified in writing.

Copyright © 2003 Underwriters Laboratories Inc.

This Standard consists of pages dated as shown in the following checklist:

Page	Date
1-6	April 30, 2003
7-9	October 26, 2001
10-12	April 30, 2003
13-18F	October 26, 2001
19	April 30, 2003
20	October 26, 2001
21	December 17, 1999
22	April 30, 2003
23-25	December 17, 1999
26-32	October 26, 2001
33-34	April 30, 2003
35-37	December 17, 1999
38-38B	October 26, 2001
39	December 17, 1999
40-44B	October 26, 2001
45-48	December 17, 1999
49	October 26, 2001
50	December 17, 1999
51-52	October 26, 2001
A1-A2	October 26, 2001
SR1-SR2B	April 30, 2003
SR3-SR4	October 26, 2001

**UL COPYRIGHTED MATERIAL –
NOT AUTHORIZED FOR FURTHER REPRODUCTION OR
DISTRIBUTION WITHOUT PERMISSION FROM UL**

No Text on This Page

***UL COPYRIGHTED MATERIAL –
NOT AUTHORIZED FOR FURTHER REPRODUCTION OR
DISTRIBUTION WITHOUT PERMISSION FROM UL***

DECEMBER 17, 1999
(Title Page Reprinted: April 30, 2003)



ANSI/UL 498A-2003

1

UL 498A

Current Taps and Adapters

First Edition

December 17, 1999

The most recent designation of ANSI/UL 498A as an American National Standard (ANSI) occurred on March 6, 2003.

This ANSI/UL Standard for Safety, which consists of the First Edition with revisions through April 30, 2003, is under continuous maintenance, whereby each revision is ANSI approved upon publication. Comments or proposals for revisions on any part of the Standard may be submitted to UL at any time. Written comments are to be sent to the UL-MEL Standards Department, 1285 Walt Whitman Road, Melville, NY 11747.

An effective date included as a note immediately following certain requirements is one established by Underwriters Laboratories Inc.

Revisions of this Standard will be made by issuing revised or additional pages bearing their date of issue. A UL Standard is current only if it incorporates the most recently adopted revisions, all of which are itemized on the transmittal notice that accompanies the latest set of revised requirements.

ISBN 0-7629-0483-6

COPYRIGHT © 2003 UNDERWRITERS LABORATORIES INC.

***UL COPYRIGHTED MATERIAL –
NOT AUTHORIZED FOR FURTHER REPRODUCTION OR
DISTRIBUTION WITHOUT PERMISSION FROM UL***

No Text on This Page

***UL COPYRIGHTED MATERIAL –
NOT AUTHORIZED FOR FURTHER REPRODUCTION OR
DISTRIBUTION WITHOUT PERMISSION FROM UL***

CONTENTS

FOREWORD	6
1 Scope	7
2 References	8
3 Glossary	9
4 Components	10
5 Units of Measurement	10
6 Ratings	10
7 Markings	10B
7.1 Company name, catalog designation, electrical rating	10B
7.2 Multiple factories	10B
7.3 AC only devices	11
7.4 Circuit limitations	11
7.5 Disconnecting use only	13
7.6 Adapters	13
7.7 Travel adapters	13
7.8 Devices with two sets of line blades	14
7.9 Devices with supplementary overcurrent protection	14
8 Installation Instructions	14
8.1 General	14
8.2 Current taps	15
8.3 Grounding adapters	15
8.4 Travel adapters	15
9 General	17
10 Insulating Materials	18C
10.1 General	18C
10.2 Flammability	18C
10.3 Electrical properties	18D
10.4 Thermal properties	18E
10.5 Vulcanized fiber	18F
10.6 Sealing compounds	18F
10.7 Fuse enclosures	18F
11 Enclosure	18F
11.1 General	18F
11.2 Male face size	19
11.3 Noninterchangeability obstructions	19
11.4 Female face size	19
12 Current-Carrying Parts	21
12.1 General	21
12.2 Blades	21
12.3 Contacts	24
13 Grounding and Dead Metal Parts	25
13.1 General	25
13.2 Blades	26
13.3 Contacts	26
14 Spacings	26
15 Assembly	28
15.1 General	28
15.2 Outlet separation	29
15.3 Grounding and polarization	29

15.4	Mating and interchangeability	.29
15.5	Fuseholders	.30A
15.6	Supplementary circuitry	.30A
15.7	Supplementary overcurrent protectors	.30B
16	Adapters	.30C
17	Travel Adapters	.30D
18	Representative Devices	.30D
19	Comparative Tracking Index Test	.32
20	Glow Wire Test	.32
21	High-Current Arc Resistance to Ignition Test	.32
22	Mold Stress Relief Test	.34
23	Moisture Absorption Resistance Test	.34
24	Dielectric Withstand Test	.35
25	Accelerated Aging Tests	.36
25.1	General	.36
25.2	Rubber, EPDM, and TEE compounds	.36
25.3	PVC compounds and copolymers	.36
26	Insulation Resistance Test	.36
27	Security of Blades Test	.37
28	Contact Security Test	.37
29	Retention of Plugs Test	.38
30	Overload Test	.38A
31	Temperature Test	.41
32	Retention of Plugs Test (Repeated)	.42
32.1	General	.42
32.2	Plug retention	.42
32.3	Plug withdrawal	.43
33	Resistance to Arcing Test	.43
34	Fuseholder Temperature Test	.44
35	Improper Insertion Test	.44A
36	Grounding Contact Tests	.46
36.1	General	.46
36.2	Conditioning	.46
36.3	Continuity	.46
36.4	Retention	.47
37	Supplementary Overcurrent Protector Temperature Test	.51

APPENDIX A

Standards for Components	A1
--------------------------	----

**UL COPYRIGHTED MATERIAL –
NOT AUTHORIZED FOR FURTHER REPRODUCTION OR
DISTRIBUTION WITHOUT PERMISSION FROM UL**

No Text on This Page

***UL COPYRIGHTED MATERIAL –
NOT AUTHORIZED FOR FURTHER REPRODUCTION OR
DISTRIBUTION WITHOUT PERMISSION FROM UL***

FOREWORD

A. This Standard contains basic requirements for products covered by Underwriters Laboratories Inc. (UL) under its Follow-Up Service for this category within the limitations given below and in the Scope section of this Standard. These requirements are based upon sound engineering principles, research, records of tests and field experience, and an appreciation of the problems of manufacture, installation, and use derived from consultation with and information obtained from manufacturers, users, inspection authorities, and others having specialized experience. They are subject to revision as further experience and investigation may show is necessary or desirable.

B. The observance of the requirements of this Standard by a manufacturer is one of the conditions of the continued coverage of the manufacturer's product.

C. A product which complies with the text of this Standard will not necessarily be judged to comply with the Standard if, when examined and tested, it is found to have other features which impair the level of safety contemplated by these requirements.

D. A product that contains features, characteristics, components, materials, or systems new or different from those covered by the requirements in this Standard, and that involves a risk of fire or of electric shock or injury to persons shall be evaluated using appropriate additional component and end-product requirements to maintain the level of safety as originally anticipated by the intent of this Standard. A product whose features, characteristics, components, materials, or systems conflict with specific requirements or provisions of this Standard does not comply with this Standard. Revision of requirements shall be proposed and adopted in conformance with the methods employed for development, revision, and implementation of this Standard.

E. UL, in performing its functions in accordance with its objectives, does not assume or undertake to discharge any responsibility of the manufacturer or any other party. The opinions and findings of UL represent its professional judgment given with due consideration to the necessary limitations of practical operation and state of the art at the time the Standard is processed. UL shall not be responsible to anyone for the use of or reliance upon this Standard by anyone. UL shall not incur any obligation or liability for damages, including consequential damages, arising out of or in connection with the use, interpretation of, or reliance upon this Standard.

F. Many tests required by the Standards of UL are inherently hazardous and adequate safeguards for personnel and property shall be employed in conducting such tests.

1 Scope

1.1 These requirements cover current taps and adapters for use in accordance with the National Electrical Code, ANSI/NFPA-70.

1.2 These requirements do not cover current taps or adapters rated at more than 200 A or for more than 600 V. See 6.1.

1.3 These requirements do not directly apply to current taps wired to flexible cord or lampholder adapters but supplement the applicable standards. Lampholder adapters are covered in the Standard for Edison-Base Lampholders, UL 496. Current taps wired to flexible cord are covered in the Standard for Attachment Plugs and Receptacles, UL 498.

1.4 These requirements do not cover cord-connected, relocatable power taps intended only for indoor use as a temporary extension of a grounding, alternating-current branch circuit for general use, and which are covered by the Standard for Relocatable Power Taps, UL 1363.

1.5 These requirements do not cover the current or voltage conversion circuitry capable of being used in travel adapters.

1.6 As used in this Standard, the term device is intended to refer to both current taps and adapters unless specifically stated otherwise.

1.7 *Deleted October 26, 2001*

2 References

2.1 Any undated reference to a code or standard appearing in the requirements of this standard shall be interpreted as referring to the latest edition of that code or standard.

2.2 The referenced standards include the following:

UL Standards

UL 94 – Tests for Flammability of Plastic Materials for Parts in Devices and Appliances

UL 248-14 – Low-Voltage Fuses - Part 14: Supplemental Fuses

UL 489 – Molded-Case Circuit Breakers, Molded-Case Switches, and Circuit-Breaker Enclosures

UL 497A – Secondary Protectors for Communications Circuits

UL 512 – Fuseholders

UL 746A – Polymeric Materials – Short Term Property Evaluations

UL 746B – Polymeric Materials – Long Term Property Evaluations

UL 746C – Polymeric Materials – Use in Electrical Equipment Evaluations

UL 746D – Polymeric Materials – Fabricated Parts

UL 1077 – Supplementary Protectors for Use in Electrical Equipment

UL 1283 – Electromagnetic Interference Filters

UL 1449 – Transient Voltage Surge Suppressors

UL 1659 – Attachment Plug Blades for Use in Cord Sets and Power-Supply Cords

UL 1681 – Wiring Device Configurations

ANSI Standards

ANSI/NEMA WD6, Wiring Devices – Dimensional Specifications

ANSI/NFPA 70, National Electrical Code

ASTM Standards

ASTM E 28-92 – Test Method for Softening Point by Ring-and-Ball Apparatus

ASTM D 570-81(1988) – Test Method for Water Absorption of Plastics

2.2 revised October 26, 2001

***UL COPYRIGHTED MATERIAL –
NOT AUTHORIZED FOR FURTHER REPRODUCTION OR
DISTRIBUTION WITHOUT PERMISSION FROM UL***

2.3 The NEMA configurations of various attachment plug and receptacle combinations referenced in this Standard are in accordance with Wiring Devices – Dimensional Specifications, ANSI/NEMA WD6. The Figures referenced as Section C3 contain non-NEMA configurations and are found in the Standard for Wiring Device Configurations, UL 1681.

2.3 revised October 26, 2001

3 Glossary

3.1 For the purposes of this Standard, the following definitions apply.

3.2 ADAPTER – A male and female contact device that adapts one blade or slot configuration to another (including a grounding adapter for a nongrounding receptacle).

3.3 ADAPTER, TRAVEL – A device that adapts the attachment plug of a portable appliance to permit its use on an electrical system that employs a male blade or pin configuration other than those found in Wiring Devices – Dimensional Specifications, ANSI/NEMA WD6 or the requirements for wiring device configurations, UL 1681. This includes adapters employing 2-pole, 2-wire and 2-pole, 3-wire blade or slot configurations rated 15 A, 125 V (1-15, 5-15) and blade or slot configurations other than found in ANSI/NEMA WD6 or UL 1681. See also 1.5.

3.4 CONFIGURATION, LOCKING – A device having a configuration that requires a motion other than a straight push or pull to connect or separate it when used with its mating part.

3.5 CONFIGURATION, MULTI- – An outlet device configuration, commonly used in travel adapters, that is designed to mate with more than one attachment plug configuration.

3.6 CURRENT TAP – A male and female contact device that, when connected to an outlet receptacle, provides multiple outlet configurations.

3.7 ELECTRICAL (FUNCTIONAL) INSULATION – The insulation necessary for the proper functioning of the product and for basic protection against electrical shock. This includes all parts relied upon to support live parts, all internal barriers necessary to maintain spacings, and the outlet face portion of all female devices.

3.8 ENCLOSURE, ELECTRICAL – That part of the device that renders inaccessible all or any parts of the device that are otherwise capable of presenting a risk of electric shock, retards propagation of flame initiated by electrical disturbances occurring within, or both.

3.9 GROUNDING DEVICE – A device having a 5-15, 5-20, 5-30, 5-50, 6-15, 6-20, 6-30, 6-50, 7-15, 7-20, 7-30, 7-50, 14-15, 14-20, 14-30, 14-50, 14-60, 15-15, 15-20, 15-30, 15-50, 15-60, L5-15, L5-20, L5-30, L6-15, L6-20, L6-30, L7-15, L7-20, L7-30, L8-20, L8-30, L9-20, L9-30, L14-20, L14-30, L15-20, L15-30, L16-20, L16-30, L17-30, L21-20, L21-30, L22-20, L22-30, L23-20, L23-30, TT-R, or ML-2R configuration, the configuration illustrated in Figure C3.8, or a nonstandard configuration that employs one blade, pin, or contact exclusively for grounding.

3.9 revised October 26, 2001

3.10 GROUNDING PATH – An electrically continuous path between the grounding pin, blade, or tab, and the grounding contact.

3.11 POLARIZED DEVICE – A device constructed for connection to a mating device only in the position that connects related poles of an electrical circuit.

**UL COPYRIGHTED MATERIAL –
NOT AUTHORIZED FOR FURTHER REPRODUCTION OR
DISTRIBUTION WITHOUT PERMISSION FROM UL**

4 Components

4.1 Except as indicated in 3.2, a component of a product covered by this standard shall comply with the requirements for that component. See Appendix A for a list of standards covering components used in the products covered by this standard.

4.1 revised October 26, 2001

4.2 A component is not required to comply with a specific requirement that:

a) Involves a feature or characteristic not required in the application of the component in the product covered by this standard, or

b) Is superseded by a requirement in this standard.

4.2 revised October 26, 2001

4.3 A component shall be used in accordance with its rating established for the intended conditions of use.

4.3 revised October 26, 2001

4.4 Specific components are incomplete in construction features or restricted in performance capabilities. Such components are intended for use only under limited conditions, such as certain temperatures not exceeding specified limits, and shall be used only under those specific conditions.

4.4 revised October 26, 2001

5 Units of Measurement

5.1 Values stated without parentheses are the requirement. Values in parentheses are explanatory or approximate information.

5.1 revised October 26, 2001

6 Ratings

6.1 The ratings mentioned throughout this Standard, including those mentioned in Table 6.1, represent maximum ampacity and maximum operating potential in volts. A device is considered to be for use on either alternating or direct current unless the rating includes the letters "AC" to restrict the use to alternating current.

6.1 revised April 30, 2003

6.2 A device shall be rated in amperes and volts. When the blade configuration of the device is one of the standard configurations in accordance with Wiring Devices – Dimensional Specifications, ANSI/NEMA WD6, the device shall be given only the rating shown in the configuration. Otherwise, the device shall be given one or more of the ratings in Table 6.1. See 6.1 and 6.3.

Exception: No. 1: Devices having a lower current rating than that shown in the configuration meet the intent of the requirement when provided with supplementary overcurrent protection of fuses.

Exception: No. 2: Devices rated AC Only meet the intent of the requirement when marked in accordance with 7.3.1.

Table 6.1
Ratings of general-use devices

Table 6.1 revised April 30, 2003

Ratings
10 A, 250 V and 15A, 125 V
15 A, 125 V
15 A, 250 V
15 A, 277 V AC
20 A, 125 V
20 A, 250 V
20 A, 277 V AC
30 A, 250 V
50 A, 250 V
60 A, 250 V
75 A, 250 V
75 A, 480 V AC
75 A, 600 V AC
75 A, 600 V
100 A, 250 V
100 A, 480 V AC
100 A, 600 V AC
100 A, 600 V
200 A, 250 V
200 A, 480 V AC
200 A, 600 V AC
200 A, 600 V

6.3 When a device includes a switch that controls an outlet, the overall rating of the device shall not be higher than the rating of the switch.

**UL COPYRIGHTED MATERIAL –
 NOT AUTHORIZED FOR FURTHER REPRODUCTION OR
 DISTRIBUTION WITHOUT PERMISSION FROM UL**

6.4 A device shall be rated for disconnecting use only, not for current rupturing, when the potential rating is higher than 250 V DC. A device rated for disconnecting use only, not for current rupturing, meets the intent of the requirement when the current rating is greater than 60 A AC, DC, or AC-DC. See 7.5.1.

6.4 revised April 30, 2003

6.5 A travel adapter shall be rated with the ratings associated with both the male and female configurations provided on the device.

6.6 A device with a nonstandard grounding configuration shall have a single ampere and single voltage rating.

7 Markings

7.1 Company name, catalog designation, electrical rating

7.1.1 A device shall be legibly and permanently marked with:

- a) The company's name, trade name, or trademark or other descriptive marking by which the organization responsible for the device is able to be identified.
- b) The electrical rating. See also 7.3.1.
- c) The catalog number or an equivalent designation, where practicable.

Exception: The catalog number is not prohibited from appearing on the unit container when the product is too small, or where the legibility is difficult to attain, or where several catalog numbers use common parts.

- d) The markings specified in 7.2 – 7.9 as applicable.

Revised 7.1.1 effective April 1, 2009

7.2 Multiple factories

7.2.1 When a manufacturer produces or assembles devices at more than one factory, each finished device shall have a distinctive marking on the device, not prohibited from being in code, by which the device is able to be identified as the product of a particular factory.

7.3 AC only devices

7.3.1 A device that is intended for use on alternating current circuits only shall be identified as such by one of the following means as a part of the electrical rating:

- a) The letters "AC";
- b) The words "AC Only";
- c) A frequency marking (for example, "60 Hertz");
- d) A phase marking such as "ϕ", the letters "ph" or "PH", or the word "phase." For multiphase devices that are intended for use only on a Wye system, the marking shall also include the word "Wye", or the letter "Y", or
- e) The symbol \sim .

7.4 Circuit limitations

7.4.1 A device intended to accommodate fuses, other than a plug or cartridge fuse intended for branch circuit protection, shall be marked "Use only with a ____ volt fuse." The potential to be used in the marking shall be the potential rating of the fuse for which the device is intended.

7.4.2 For non-permanent adapters, when the male configuration amperage rating is less than the female configuration amperage rating, the device shall be marked "Caution" and with the following or equivalent statement, "To avoid overloading the receptacle and branch circuit, limit use to ____ amperes maximum." The ampere rating to be used in the marking shall be the ampere rating of the male configuration.

No Text on This Page

***UL COPYRIGHTED MATERIAL –
NOT AUTHORIZED FOR FURTHER REPRODUCTION OR
DISTRIBUTION WITHOUT PERMISSION FROM UL***

7.5 Disconnecting use only

7.5.1 A device intended exclusively for disconnecting use shall be marked with one of the following or equivalent statements, "For disconnecting use only" or "Not for current rupturing."

7.6 Adapters

7.6.1 An adapter having a grounding tab, lug, or similar device described in 16.1 – 16.3 shall be marked with the word "CAUTION," and the following or equivalent statement, "Risk of Electric Shock. Must connect green (or "GR") tab under cover plate screw." This marking shall be marked on each adapter where visible during installation.

Revised 7.6.1 effective April 1, 2009

7.6.2 An adapter employing a movable male grounding pin or blade shall be marked with a statement making it clear that the adapter is for use with a portable hand-held, hand-guided, or hand-supported tool or appliance. See 16.1

7.7 Travel adapters

7.7.1 A travel adapter that allows an attachment plug to mate with an outlet device having a different voltage rating than that of the plug shall be marked on the device where visible during use "CAUTION" and the following instructions or the equivalent: "For Dual-Voltage Appliances Only – Before Inserting, Set Appliance Switch to ____ V Setting. Do Not Use with Products Having a Single ____ V Voltage Rating. SEE INSTRUCTIONS BEFORE USING." The first blank is to be filled in with the voltage rating associated with the blade configuration of the adapter. The second blank is to be filled in with the voltage rating associated with the outlet configuration of the adapter.

7.7.2 A travel adapter with outlet slots that are polarized, and male blades or pins for use in an electrical system that does not have provision for polarization shall be marked on the device where visible during use with the word "CAUTION" and the following statements or their equivalents:

- a) "To reduce the risk of electric shock from exposed live parts, do not use with appliances provided with a lampholder or an electrical outlet," and
- b) "To reduce the risk of fire or electric shock, grasp travel adapter and plug and remove from the receptacle when not in use."

7.7.3 A multi-configuration travel adapter shall be marked with the word "CAUTION" and the following statement or the equivalent: "To reduce risk of fire or electric shock, use only with these plug types," together with an outline drawing of the appropriate plug configurations. The marking shall appear on the device where it will be visible during use.

7.8 Devices with two sets of line blades

Added Sub-section 7.8 effective April 1, 2009

7.8.1 A device with two sets of line blades shall be marked, where visible during installation, with the following:

- a) "Not for use with ground-fault circuit-interrupter receptacles or receptacles with indicator lights or controls", or the equivalent.
- b) For a device having a blade spacing in accordance with Figure 9.1, "CAUTION - To reduce the risk of fire or electric shock, do not use this device with a receptacle in which the slot openings do not align with the blades", or an equivalent wording following the word "CAUTION".
- c) For a device having a blade spacing not in accordance with Figure 9.1, "CAUTION - To reduce the risk of fire or electric shock, do not use this device with receptacles other than those specified in the installation instructions", or an equivalent wording following the word "CAUTION".

7.9 Devices with supplementary overcurrent protection

Added Sub-section 7.9 effective April 1, 2009

7.9.1 The outlets of a device with supplementary overcurrent protection shall be marked, where visible after installation, to indicate the rating of the overcurrent protector that supplies them.

Exception: This marking is not required when the overcurrent protection is full-rated for the outlet configuration.

8 Installation Instructions

8.1 General

8.1.1 Unless otherwise specified in this section, installation instructions shall appear on the device, on the smallest unit container, or on a separate instruction sheet provided with each device. If the installation instructions are provided on the smallest unit container or on a separate sheet, they shall be attached to the device in such a manner that they are unable to become detached during normal conditions of handling and storage prior to initial installation or usage. The use of an individual carton, blister pack, or equivalent securing of the device to the instructions, meets the intent of the requirement. However, friction attachment shall not be employed.

Added 8.1.1 effective April 1, 2009

8.2 Current taps

8.2.1 A device intended for installation with the receptacle cover plate or cover plate screw removed shall be provided with detailed installation instructions to enable proper installation of the device with the cover plate removed. The inclusion of a pictorial representation is optional.

Added 8.2.1 effective April 1, 2009

8.2.2 A device intended for installation over receptacle cover plates of specific dimensions shall be provided with installation instructions that describe the maximum overall dimensions of the receptacle cover plate with which the device is intended to be used.

Added 8.2.2 effective April 1, 2009

8.2.3 A device having a blade spacing not in accordance with Figure 9.1 shall be provided with installation instructions that specify, by catalog number or equivalent designation, the receptacles with which the device is to be used.

Added 8.2.3 effective April 1, 2009

8.2.4 A device that does not provide electrical continuity between any metal cover plate and the cover plate mounting screw boss of the receptacle on which the device is intended to be used shall be provided with installation instructions requiring the user to replace the metal cover plate with a non-metallic cover plate.

Added 8.2.4 effective April 1, 2009

8.3 Grounding adapters

Added Sub-section 8.3 effective April 1, 2009

8.3.1 A grounding adapter shall be provided with installation instructions that include the words, "CAUTION - Risk of electric shock. Grounding continuity must be maintained. Consult a qualified electrician to determine whether cover plate screw is grounded. Fasten green tab under cover plate screw. Do not use this adapter on extension cords or on receptacles where the green tab cannot be connected", or an equivalent wording following the word "CAUTION".

8.4 Travel adapters

8.4.1 An instruction sheet, booklet or the equivalent shall be provided with each travel adapter. The instructions shall specifically warn the user of reasonably foreseeable risks and state the precautions to be taken to reduce such risks. The letters and text in 8.4.3 shall not be less than 2.0 mm (5/64 inch) high for upper-case letters and 1.6 mm (1/16 inch) high for lower-case letters. "IMPORTANT SAFETY INSTRUCTIONS" and "SAVE THESE INSTRUCTIONS" shall be in letters not less than 4.8 mm (3/16 inch) high.

8.4.2 The text of the instructions shall be verbatim to, or in equally definitive terminology as 8.4.3, except where specific conflict of the application to a product exists. The phrases "IMPORTANT SAFETY INSTRUCTIONS" and "SAVE THESE INSTRUCTIONS" shall be first and last, respectively, in a list of items. Other important safety instructions determined appropriate by the manufacturer are to be included.

8.4.3 The following instructions shall be provided with a travel adapter:

“IMPORTANT SAFETY INSTRUCTIONS”

“When using your travel adapter, basic precautions should always be followed, including the following”:

- a) “READ ALL INSTRUCTIONS BEFORE USING.”
- b) “DO NOT use this adapter with products containing screw-base lampholders (sockets) or convenience receptacles.”

Exception: This instruction need only be provided for a travel adapter that has polarized outlet slots and non-polarized blades or pins.

- c) “THIS PRODUCT IS NOT A VOLTAGE CONVERTER. Check the markings on each appliance and use this adapter only with appliances rated for both 120 and 240 volts. Using appliances rated only 120 volts with this adapter may result in a risk of fire, electric shock, injury to persons, or damage to the appliance.”
- d) “Be sure the dual-voltage selector switch, when provided, is in the correct voltage position before operating. Before plugging in, read the information about dual-voltage operation contained in these instructions and in the instructions provided with each appliance to be used with this adapter.”
- e) “Always attach the adapter to the plug of the appliance first, then insert the adapter into the outlet.”
- f) “Always disconnect the adapter and appliance from the electrical outlet when not in use.”
- g) **“SAVE THESE INSTRUCTIONS”**

8.4.4 The instructions for a travel adapter shall include information about dual-voltage operation, including the following:

- a) The statement “For use in the U.S.A., the appliance’s voltage selector switch should be placed in the 120-volt position. For use in countries overseas, the voltage selector may need to be placed in the 240-volt position. Confirm the voltage available at each overseas location before using this adapter with an appliance,” or the equivalent.
- b) A tabulation including the following information:
 - 1) A diagram of each male blade or pin configuration that the adapter will accept. This column shall be headed “WHEN APPLIANCE HAS THIS PLUG,” or the equivalent.
 - 2) A list of countries which employ the female outlet configuration that corresponds to the male blade or pin configuration used by each adapter. This column shall be headed “TO USE IN,” or the equivalent.
 - 3) The voltage rating associated with the male configuration in each country. This column shall be headed “SET SELECTOR AT,” or the equivalent.

9 General

9.1 Revised and relocated as 9.5 effective April 1, 2009

9.2 Revised and relocated as 9.6 effective April 1, 2009

9.3 Revised and relocated as 9.8 effective April 1, 2009

9.4 Revised and relocated as 9.7 effective April 1, 2009

9.5 A device shall employ one or two sets of male blades as line connections only. Load connections shall consist of outlets. Male blades shall not be employed for load connections.

9.5 added as revised and relocated from 9.1 effective April 1, 2009

9.6 A device shall have a maximum of three outlets supplied from one set of line blades.

Exception: A device that complies with 9.7, 9.8, or 9.9 is not required to comply with this requirement. See Table 9.1.

9.6 added as revised and relocated from 9.2 effective April 1, 2009

Table 9.1
Line and load connections
Added Table 9.1 effective April 1, 2009

No. of sets of line blades ^a	No. of outlets per set of line blades	Inhibits the use of the other outlet of the duplex receptacle ^b	Supplementary overcurrent protection required
1	3 or less	no	no
1	4 - 6	no	yes
1	4 - 6	yes	no
1	more than 6	yes	yes
2	3 or less	yes	no ^c
2	more than 3	yes	yes ^c

^a Includes only conducting line blades. See 9.10.
^b Provided with contact spacing as shown in Figure 9.1.
^c When a device with two sets of blades has one set feeding three outlets or less and one set feeding more than three outlets, the set feeding three outlets or less is not required to have supplementary overcurrent protection, but the set feeding more than three outlets is required to have supplementary overcurrent protection.

9.7 A device with four to six outlets and one set of line blades shall:

- a) Inhibit, in any position, the electrical use of the other outlet when mounted on or plugged into a duplex receptacle; or
- b) Be provided with supplementary overcurrent protection as described in 15.7.

9.7 added as revised and relocated from 9.4 effective April 1, 2009

9.8 A device with two sets of line blades and up to six outlets:

- a) Shall not have more than three outlets per set of blades; and
- b) Shall comply with 9.12 and 9.13.

Added 9.8 added as revised and relocated from 9.3 effective April 1, 2009

9.9 A device with more than six outlets and one or two sets of line blades shall:

- a) Be provided with supplementary overcurrent protection as described in 15.7;
- b) Inhibit, in any position, the electrical use of the other outlet when mounted on or plugged into a duplex receptacle provided with contact spacings as shown in Figure 9.1;
- c) Be provided with a means other than the blades, such as a screw, for mounting to the receptacle; and
- d) Comply with 9.10 and 9.11 (as applicable) when provided with two sets of line blades.

Added 9.9 effective April 1, 2009

9.10 A device provided with a second set of line blades for increased stability that are electrically isolated from the line contacts of the outlets ("dummy blades") shall comply with 9.12 and 9.13.

Added 9.10 effective April 1, 2009

9.11 A device provided with a second ground pin for increased stability (not necessarily isolated from the grounding contacts of the receptacles) shall comply with 9.12 and 9.13.

Added 9.11 effective April 1, 2009

9.12 A device provided with two sets of line blades shall comply with all of the following:

- a) The distance between the two sets of blades shall be in accordance with Figure 9.1;

Exception: Devices marked in accordance with 7.8.1 (c) are not required to comply with this requirement.

- b) The device shall be marked in accordance with 7.8.1 (a) and (b); and
- c) When the device employs line blades of the 1-15P configuration, the line blades and contacts shall employ only the polarized construction.

Added 9.12 effective April 1, 2009

9.13 A device provided with two sets of line blades shall not employ an electrical connection between the two sets of line blades associated with each outlet of the duplex receptacle.

9.13 added October 26, 2001

9.14 A device intended for installation requiring the removal of a receptacle cover plate shall comply with the following:

- a) The device shall be able to be fully inserted in the outlets; and

b) The device shall be able to be fully seated against the wall such that the outlet box opening in the wall is completely covered.

Added 9.14 effective April 1, 2009

9.15 A device intended for installation where neither the receptacle cover plate or its mounting screw are intended to be removed shall be able to be fully inserted in the outlets with the receptacle cover plate in place, independent of the overall dimensions of the cover plate.

Exception: A device intended for installation over a receptacle cover plate with specific dimensions shall be provided with installation instructions in accordance with 8.2.2.

Added 9.15 effective April 1, 2009

9.16 A device intended for installation where the receptacle cover plate is not intended to be removed but the mounting screw is intended to be replaced with the mounting screw of the device shall comply with the following:

a) The device shall be able to be fully inserted in the outlets with the receptacle cover plate in place, independent of the overall dimensions of the cover plate;

Exception: A device intended for installation over a receptacle cover plate with specific dimensions shall be provided with installation instructions in accordance with 8.2.2.

b) The device shall provide electrical continuity between any metal cover plate and the cover plate mounting screw boss of the receptacle on which the device is intended to be mounted.

Exception: A device provided with installation instructions requiring the user to replace the metal cover plate with a non-metallic cover plate in accordance with 8.2.4 is not required to comply with this requirement.

c) The device shall be capable of mechanically securing the receptacle cover plate to the receptacle.

Exception: The device is not required to comply with this requirement when the device completes the enclosure of live parts, independent of the receptacle coverplate.

Added 9.16 effective April 1, 2009

Figure 9.1
Blade and contact spacing

Added Figure 9.1 effective April 1, 2009

No. 6-32 Mounting
Screw (Optional)

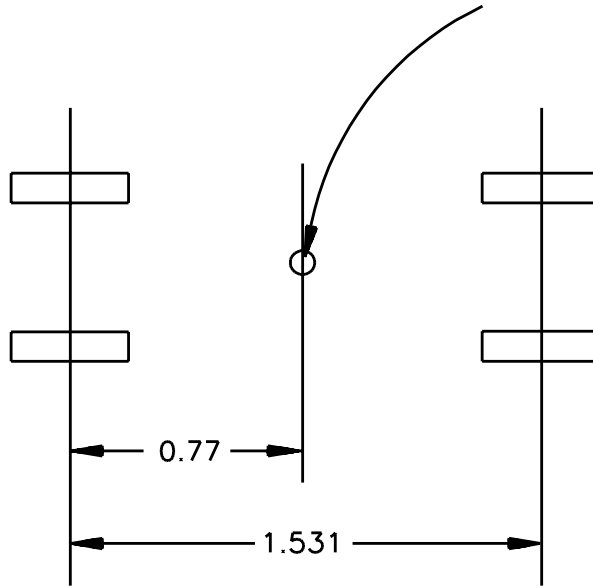

1-15
(Nongrounding)

No. 6-32 Mounting
Screw (Optional)

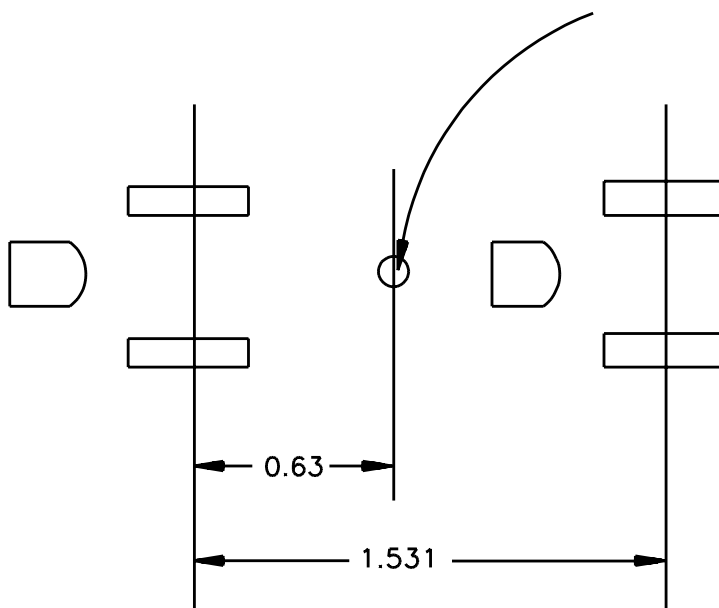

5-15
(Grounding)

S3778C

10 Insulating Materials

10.1 General

10.1.1 All parts that act as the electrical insulation or enclosure of a device shall be made of insulating material intended for the particular application and shall comply with the requirements in 10.2 – 10.7. Hard rubber shall not be employed.

Exception No. 1: The internal insulating systems of components where component requirements exist are not required to comply with the requirements in 10.2 – 10.7.

Exception No. 2: A small part meeting all of the following criteria is not required to comply with the requirements in 10.2 – 10.7:

- a) Its volume does not exceed 2 cm³(0.122 cubic inch),*
- b) Its maximum dimension does not exceed 3 cm (1.18 inches), and*
- c) Its location is such that it cannot propagate flame from one area to another or act as a bridge between a possible source of ignition and other ignitable parts.*

Exception No. 3: Fiber or similar material that is equal to or less than 0.25 mm (0.010 inch) thick is not required to comply with the requirements in 10.2 – 10.7.

10.1.2 A polymeric material used for electrical insulation or enclosure of live parts shall comply with the Standard for Polymeric Materials – Fabricated Parts, UL 746D:

- a) When fabricated in a location other than where the final assembly takes place, or
- b) When blending or compounding operations are involved.

10.2 Flammability

10.2.1 A polymeric material used for electrical (functional) insulation or enclosure of live parts shall have a flame class rating of HB, V-2, V-1, V-0, VTM-2, VTM-1, or VTM-0 in accordance with the Standard for Tests for Flammability of Plastic Materials for Parts in Devices and Appliances, UL 94. The flame class rating of the material shall be judged at the nominal minimum thickness employed at the walls and barriers in the device which are critical to the functioning of the insulation or enclosure of the device.

10.2.1 revised October 26, 2001

10.3 Electrical properties

10.3.1 A polymeric material used for electrical insulation or enclosure of live parts shall have a Comparative Tracking Index (CTI) rating of 175 V or greater or a performance level class of at least 3.

Exception No. 1: A polymeric material used for electrical insulation or enclosure of live parts is not required to comply with this requirement when it complies with the Comparative Tracking Index Test, Section 19.

Exception No. 2: A polymeric material used in an enclosure that is separated through air by more than 0.8 mm (1/32 inch) from uninsulated live parts and more than 12.7 mm (1/2 inch) from arcing parts is not required to comply with this requirement.

10.3.2 A polymeric material used for electrical insulation or enclosure of live parts shall have Hot Wire Ignition (HWI) and High-Current Arc Resistance to Ignition (HAI) ratings or performance level classes of at least those shown in Table 10.1 for the flame class rating determined in accordance with 10.2.1. For materials with other than VTM flammability classifications, the HWI and HAI ratings of the material shall be evaluated using the specimen thickness employed in the end product or nominal 1/8 inch (3.2 mm) thickness, whichever is greater.

Exception No. 1: A polymeric material used for electrical insulation or enclosure of live parts is not required to comply with the HWI requirements when it complies with the Glow Wire Test, Section 20.

Exception No. 2: A polymeric material used for electrical insulation or enclosure of live parts is not required to comply with HAI requirements when it complies with the High-Current Arc Resistance to Ignition Test, Section 21.

Exception No. 3: A polymeric material used in an enclosure that is separated through air by more than 0.8 mm (1/32 inch) from uninsulated live parts and more than 12.7 mm (1/2 inch) from arcing parts is not required to comply with the HWI and HAI requirements.

Table 10.1
Hot wire ignition (HWI) and high-current arc resistance to ignition (HAI) ratings of insulating materials

Table 10.1 revised October 26, 2001

Flammability classification ^a	HWI ^{b,d}		HAI ^{c,d}	
	Mean ignition time (sec)	PLC	Mean no. of arcs	PLC
V-0, VTM-0	7 and up to 15	4	15 and up to 30	3
V-1, VTM-1	15 and up to 30	3	15 and up to 30	3
V-2, VTM-2	15 and up to 30	3	15 and up to 30	3
HB	30 or more	2	60 or more	1

^a Flammability Classification – Described in the requirements for flammability of plastic materials for parts in devices and appliances, UL 94.
^b Hot Wire Resistance to Ignition – Described in the Standard for Polymeric Materials – Short Term Property Evaluations, UL 746A.
^c High-Current Arc Resistance to Ignition – Described in UL 746A.
^d Mean ignition time and mean no. of arcs to be used to evaluate Filament Wound Tubing, Industrial Laminates, Vulcanized Fiber, and similar polymeric materials only. All other materials are to be judged using the performance level class values.

UL COPYRIGHTED MATERIAL –
NOT AUTHORIZED FOR FURTHER REPRODUCTION OR
DISTRIBUTION WITHOUT PERMISSION FROM UL

10.4 Thermal properties

10.4.1 A polymeric material used for electrical insulation or enclosure of live parts shall have the relative thermal index ratings shown in Table 10.2 for the specific application of the insulating material. For materials with other than VTM flammability classifications, the material shall be evaluated using the specimen thickness employed in the end product or nominal 1/8 inch (3.2 mm) thickness, whichever is greater.

Exception: The following generic materials having readings of 65 or less on the Shore Durometer D scale [when measured for 5 seconds at an ambient temperature of $23.0 \pm 2.0^\circ\text{C}$ ($73.4 \pm 3.6^\circ\text{F}$)] are intended for use at 60°C (140°F) based on their successful completion of the appropriate accelerated aging test described in Accelerated Aging Tests, Section 25:

- a) Ethylene/Propylene/Diene (EPDM)
- b) Natural Rubber (NR)
- c) Neoprene (Chloroprene Butadiene) Rubber (CBR)
- d) Nitrile Rubber (NBR)
- e) Polyvinyl Chloride (PVC) and its copolymers
- f) Silicone Rubber (SIR)
- g) Styrene (Butadiene) Rubber (SBR)
- h) Thermo Elastomeric [TEE; includes Thermoplastic Elastomers (TPE) and Ethylene Propylene Thermoplastic Rubber (EPTR)]

Table 10.2
Minimum relative thermal indices of insulating materials used in insulation and enclosure applications

Application	Minimum relative thermal index ^a , Degrees C		
	Electrical	Mechanical with impact ^b	Mechanical without impact
Devices provided with a means for fixed attachment to a receptacle	80 ^c	60 ^c	80 ^c
Devices not provided with a means for fixed attachment to a receptacle	60 ^c	60 ^c	60 ^c
^a Relative Thermal Index – Described in the Standard for Polymeric Materials – Long Term Property Evaluations, UL 746B. ^b For industrial laminates, vulcanized fiber, and similar polymeric materials, the material's minimum RTI for Mechanical shall be evaluated using the values specified for Mechanical Without Impact. ^c For devices containing fuses, the minimum thermal indices shall be the values shown above or the temperature measured on the insulating material during the Fuseholder Temperature Test, Section 34, whichever is greater.			

10.5 Vulcanized fiber

10.5.1 Vulcanized fiber is not prohibited from being used for insulating washers, separators, and barriers, but shall not be used as the sole support of live parts.

10.5.2 Vulcanized fiber shall comply with the requirements in 10.2 – 10.4 and shall be moisture-resistant in accordance with 23.1 and 23.2.

10.6 Sealing compounds

10.6.1 A sealing compound shall be insulating, moisture-resistant, and shall not soften at a temperature of 65°C (149°F). The softening point is to be determined using the Test Method for Softening Point by Ring-and-Ball Apparatus, ASTM E 28-92.

10.6.2 Sulphur shall not be employed as a sealing compound.

10.7 Fuse enclosures

10.7.1 A fuse enclosure shall be of a moisture-resistant material in accordance with 23.1 and 23.2. Fiber and similar absorptive materials shall not be used as the enclosure of a fuse.

10.7.2 The enclosure of a fuse shall have a minimum flame class rating of V-2.

11 Enclosure

11.1 General

11.1.1 A device shall have live parts protected against exposure to contact by persons when fully assembled using all essential parts and installed in the intended manner. A separable part is essential for the operation of the device when it requires the use of a tool for removal or is provided with an interlock, and it performs the following functions:

- a) Encloses or completes the enclosure of current-carrying parts, or
- b) Provides for the placement and removal of a fuse.

Exception: Male blades which are energized only when mated with the corresponding outlet are not required to comply with this requirement.

11.1.2 Accessible dead-metal parts of a grounding device shall be conductively connected to the grounding path through the device.

Exception: Accessible dead-metal parts electrically insulated from current-carrying parts are not required to comply with this requirement.

11.1.3 Accessible dead-metal parts of a nongrounding device shall be electrically insulated from live parts.

11.1.4 In order to judge the accessibility of a live or dead-metal part, the probe shown in Figure 11.1 is to be applied to the device with a force of 13 N (3 lbf) to any depth that recessing will permit. The probe is to be rotated, changed in configuration, or angled before, during, and after application to any position that is necessary to examine the device. A live or dead-metal part is determined to be accessible when:

- a) The part is contacted by the probe, or
- b) The part is located in a hole larger than 7.1 mm (9/32 inch) in diameter and recessed less than 4.8 mm (3/16 inch).

11.2 Male face size

11.2.1 The perimeter of the male face of a 2-wire, parallel-blade, 1-15P configuration device shall encompass an area equal to or larger than that indicated in Figure 11.2.

11.3 Noninterchangeability obstructions

11.3.1 The face of a nongrounding outlet device of the 1-15R configuration shall obstruct the insertion of a grounding attachment plug of the 5-15P configuration. The face of a grounding outlet device of the 5-15R, 6-15R, 5-20R, 6-20R, or 6-30R configuration shall obstruct the insertion of either its respective mating plug in the reverse direction in an attempt to deflect the ground pin to the outside of the face when inserting the line blades, or a dissimilarly rated grounding attachment plug.

Revised 11.3.1 effective April 1, 2009

11.3.2 The obstruction required by 11.3.1 is to have the minimum size and shape indicated as the shaded portions of Figure 11.3. The obstructions are to be coplanar with the face or recessed by not more than 2.4 mm (3/32 inch). Devices having rigid bodies, materials having a minimum hardness of 90 when measured on the "A" scale of a Shore Durometer, having the indicated "A" dimension reduced to 13.5 mm (0.531 inch) meet the intent of the requirement.

11.4 Female face size

11.4.1 The outlet face of a 2-wire, parallel-slot device of the 1-15R configuration, or a multi-configuration adapter that accepts attachment plugs with the 1-15P configuration, shall have a perimeter that encompasses an area equal to or larger than that indicated in Figure 11.4, and shall include an obstruction whose minimum size and location are indicated by the shaded portions of that figure.

Revised 11.4.1 effective April 1, 2009

Figure 11.1
Articulate probe with web stop

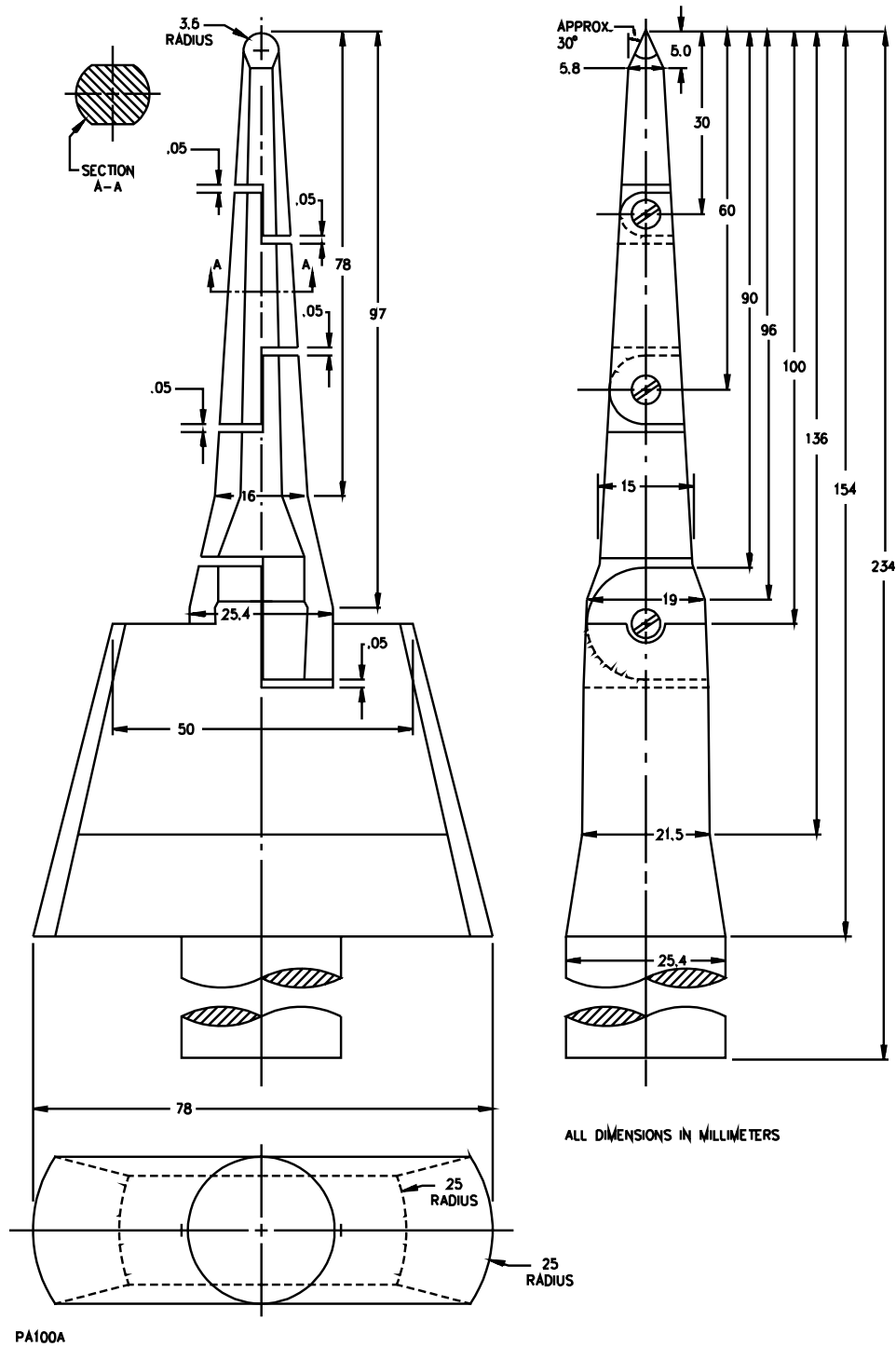

PA100A

UL COPYRIGHTED MATERIAL –
NOT AUTHORIZED FOR FURTHER REPRODUCTION OR
DISTRIBUTION WITHOUT PERMISSION FROM UL

Figure 11.2
Minimum current tap or adapter face dimensions

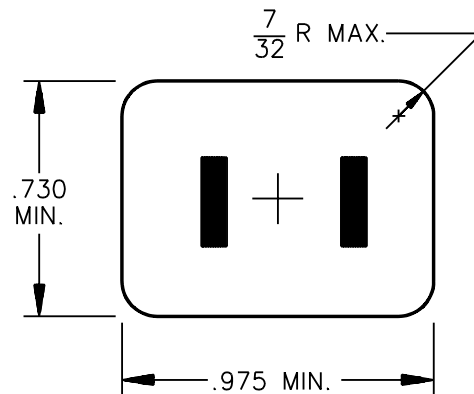

BLADES CENTERED

mm	5.6	18.5	24.8
inch	7/32	0.730	0.975

SA1945D

11.4.2 A device shall enclose all live parts in insulating material. The integrity of the enclosure of the female contacts shall be maintained when tested as described in Contact Security Test, Section 28.

12 Current-Carrying Parts

12.1 General

12.1.1 Iron or steel, plated or unplated, shall not be used for parts that are depended upon to carry current, except that stainless steel is not prohibited for a part not subject to arcing.

12.1.2 A current-carrying part shall be restricted from turning relative to the surface on which it is mounted when such turning would adversely affect the performance of the device.

12.1.3 Uninsulated live parts shall be secured in place so that a reduction in the spacings below those required in 14.1 is not likely.

12.2 Blades

12.2.1 Blades shall have dimensions in accordance with Wiring Devices – Dimensional Specifications, ANSI/NEMA WD6.

12.2.2 Folded-over blades employed in a device having a 1-15P, 2-15P, 2-20P, 5-15P, 5-20P, 6-15P, 6-20P configuration shall additionally comply with the dimensional requirements of the Standard for Attachment Plug Blades for Use in Cord Sets and Power-Supply Cords, UL 1659.

Figure 11.3
Faces of outlet device showing location and minimum dimensions of obstructions

Revised Figure 11.3 effective April 1, 2009

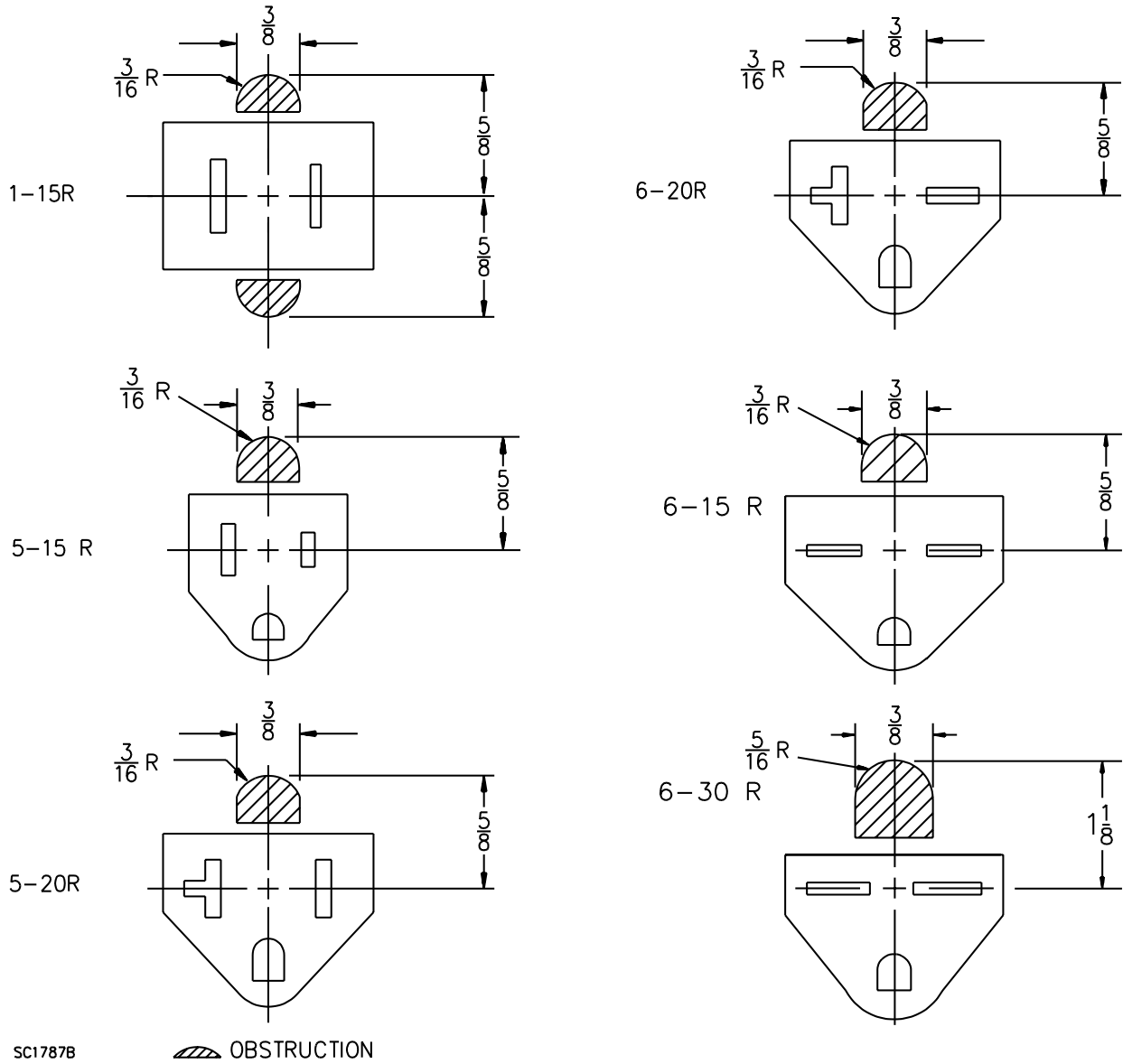

Inch	3/16	5/16	3/8	5/8	1-1/8
mm	4.8	7.9	9.5	15.9	28.6

UL COPYRIGHTED MATERIAL –
NOT AUTHORIZED FOR FURTHER REPRODUCTION OR
DISTRIBUTION WITHOUT PERMISSION FROM UL

Figure 11.4
Minimum outlet face dimensions

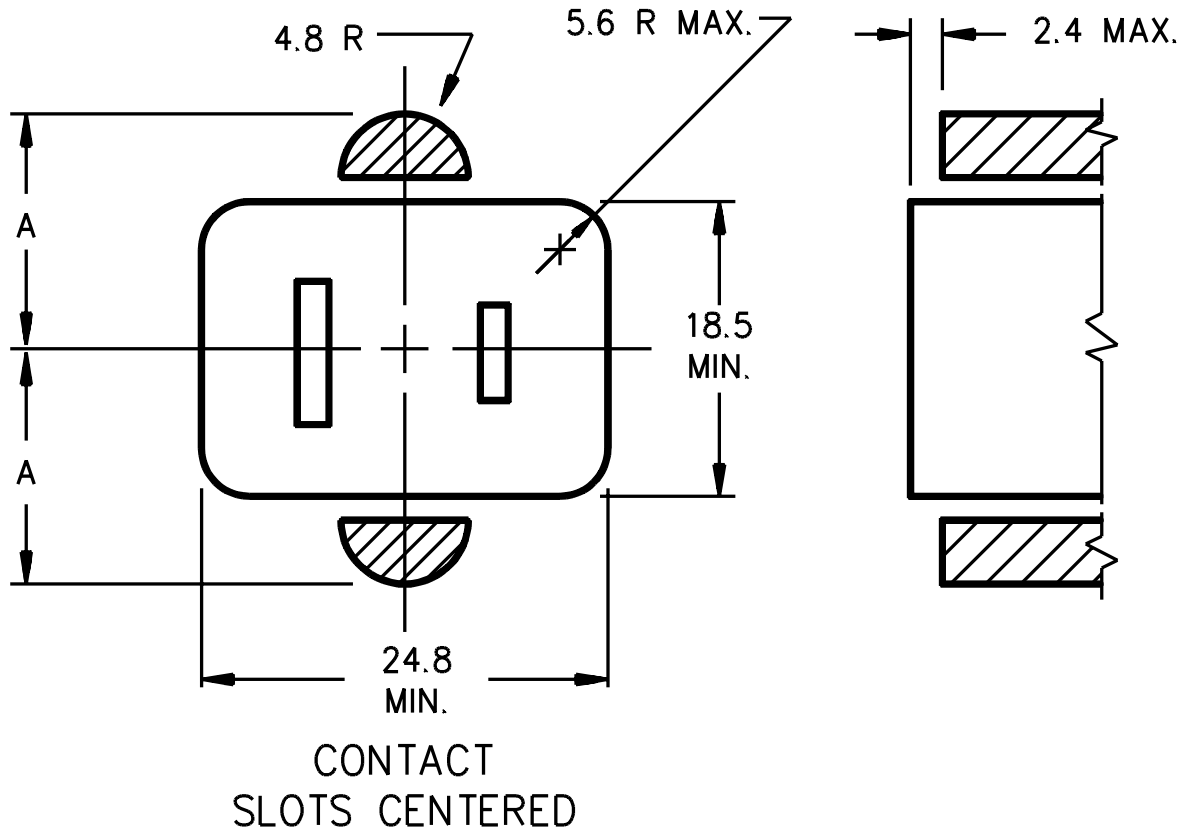

ALL DIMENSIONS IN MILLIMETERS

mm	2.4	4.8	5.6	18.5	24.8
inch	3/32	3/16	7/32	0.730	0.975

Dimension A mm (inch)	Shore durometer hardness (Scale A)
15.9 (0.625)	less than 90
13.5 (0.531)	90 or more

SA1946B

UL COPYRIGHTED MATERIAL –
NOT AUTHORIZED FOR FURTHER REPRODUCTION OR
DISTRIBUTION WITHOUT PERMISSION FROM UL

12.2.3 The folded-over blades of 15 or 20 A devices shall be formed from stock that is 0.71 – 0.81 mm (0.028 – 0.032 inch) thick.

Exception: Folded-over blades formed from stock less than 0.71 mm (0.028 inch) thick meet the intent of the requirement when the stock is not less than 0.51 mm (0.020 inch) thick and both ends of the blade are securely retained within the body of the device, such that the overall thickness is maintained.

12.3 Contacts

12.3.1 Except as noted in 12.3.5, female current-carrying contacts and associated live parts in the contact opening of an outlet device that are capable of being touched by the probe illustrated in Figure 12.1, shall be recessed from the plane of the opening a distance not less than 1/4 of the maximum straight-line dimension of the opening, or 1.2 mm (3/64 inch), whichever is larger.

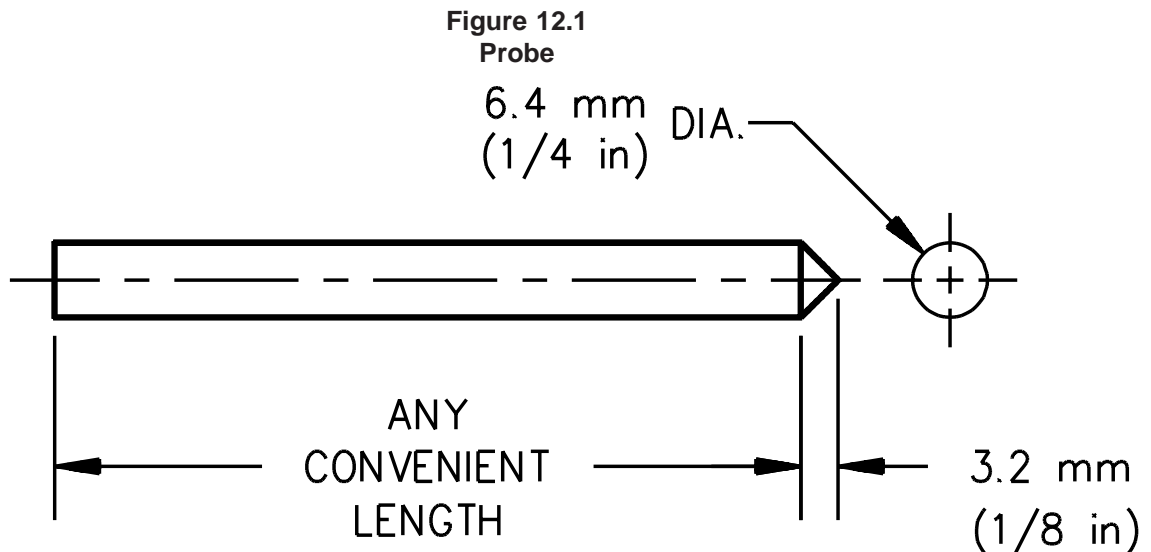

PA190A

12.3.2 That plane nearest the face of the device having the minimum opening for the pin or blade clearance is to be used to determine the minimum recess specified in 12.3.1. Bevels, tapers, or other expansions of the opening to the face of the device are to be disregarded.

12.3.3 The probe in Figure 12.1 is to be inserted point first as far as possible in the opening without distorting the perimeter of the opening.

12.3.4 The maximum straight-line dimension is the maximum-length straight-line that will fit within the opening at the plane of measurement.

**UL COPYRIGHTED MATERIAL –
NOT AUTHORIZED FOR FURTHER REPRODUCTION OR
DISTRIBUTION WITHOUT PERMISSION FROM UL**

12.3.5 Devices having openings that close upon removal of the attachment plug, and specific-purpose devices intended only for disconnecting use (see 6.4 and 7.5.1), are not subject to the requirements in 12.3.1.

13 Grounding and Dead Metal Parts

13.1 General

13.1.1 The following grounding parts shall be of copper or of a copper-base alloy:

- a) The grounding pin, blade, tab, or grounding contact, and
- b) The grounding path through a device, except for a metal housing or armor.

13.1.2 A rivet, bolt, or clamp that is used to secure parts in the grounding path, but which is not an essential conductor in the grounding path, is not prohibited from being made of steel or its equivalent.

13.1.3 A copper-base-alloy rivet that is used to secure parts in the grounding path, or that forms a part of the grounding path, shall not contain less than 80 percent copper.

13.1.4 The grounding-path connections in a grounding device shall be secured by riveting, bolting, welding, or equivalent means.

13.1.5 The grounding pin, blade, tab, or contact, of a grounding device shall be permanently attached to the body of the device.

13.1.6 The requirement in 13.1.5 does not preclude a device in which the grounding pin or blade is mounted in soft rubber or similarly flexible material. The requirement contemplates that the element is to be secured in a manner so that it is not readily removable.

13.1.7 Grounding and other dead metal parts shall be secured in place so that a reduction in spacings below those required in 14.1 is not likely.

13.1.8 Except where electrically insulated from current-carrying parts and wiring, dead-metal parts of a grounding device shall be conductively connected to the grounding path through the device. See 11.1.2.

13.1.9 A conductive connection between a blade, pin, tab, or contact, and an exposed dead-metal part capable of being grounded in service, such as body armor, shall be provided only in a grounding device.

13.1.10 Dead metal parts of a device for use in nongrounding applications where there is no provision for grounding the dead metal parts shall be insulated from live parts. See 11.1.3.

13.1.11 Iron or steel other than machine screws, washers, nuts, and stainless steel parts shall be protected against corrosion.

13.1.12 The current tap mentioned in 9.3 and any other similar device that can accommodate a 3-wire grounding attachment plug having a 5-15P, 5-20P, 6-15P, 6-20P, 7-15P, 14-15P, or 14-60P configuration shall comply with the requirements of the Grounding Contact Tests, Section 36. See also 16.2.

13.2 Blades

13.2.1 For devices with a 5-15P, 5-20P, 5-30P, 5-50P, 6-15P, 6-20P, 6-30P, 6-50P, 7-15P, 7-20P, 7-30P, 7-50P, 14-15P, 14-20P, 14-30P, 14-50P, 14-60P, 15-15P, 15-20P, 15-30P, 15-50P, 15-60P, L5-15P, L7-15P, TT-R, or ML-2R configuration, a blade to be used for grounding (G in the figures) shall be longer (see respective figures) than the other blades. For a device with some other configuration, the construction of the device shall be such that, when the device is inserted into its corresponding receptacle, contact between the grounding blade and the corresponding outlet contact will be made before contact between the other blades and their corresponding contacts.

13.2.1 revised October 26, 2001

13.2.2 The grounding blade or pin of a 15- or 20-A nonlocking type current tap or adapter shall not contain surface discontinuities that would tend to interfere with insertion into, or withdrawal from a grounding contact of an outlet device. Abrupt surface transitions such as gaps, steps, offsets, detents, holes or sharp chamfers are specifically prohibited in the following areas shown in Figure 13.1:

- a) The shaft, and
- b) The transition zone between the tip and the shaft which is likely to engage the grounding contact during insertion or withdrawal.

13.2.2 revised October 26, 2001

13.3 Contacts

13.3.1 The grounding contact in a grounding-type outlet shall be located and formed so that the path of electrical continuity to the grounding pin or blade of a mating attachment plug is completed before continuity is established between any other contact and its respective pin or blade on the attachment plug. This grounding path shall be substantial when the attachment plug is properly seated in the receptacle.

14 Spacings

14.1 There shall be a spacing through air or over surface of not less than 1.2 mm (3/64 inch) for a device rated 250 V or less, and not less than 3.2 mm (1/8 inch) for a device rated more than 250 V, between uninsulated live parts of opposite polarity and between an uninsulated live part and a dead-metal part that is likely to be grounded or exposed to contact by persons when the device is installed as intended.

14.2 The dead metal mentioned in 14.1 includes a metal surface (a metal face plate in the case of a flush receptacle) on which the device is mounted in the intended manner. A dead-metal screw head, rivet, or similar part is not considered to be exposed to contact by persons after the device is installed in the intended manner, when the dead metal is located in a hole not larger than 7.1 mm (9/32 inch) in diameter and recessed not less than 4.8 mm (3/16 inch) in the clear.

14.3 The spacing of an electrically-insulated dead-metal part interposed between live parts of opposite polarity, or between a live part and a grounded or exposed dead-metal part, is to be reduced by an amount equal to the dimension of the insulated dead-metal part in the direction of the measurement.

Figure 13.1
Grounding pin profiles

Figure 13.1 added October 26, 2001

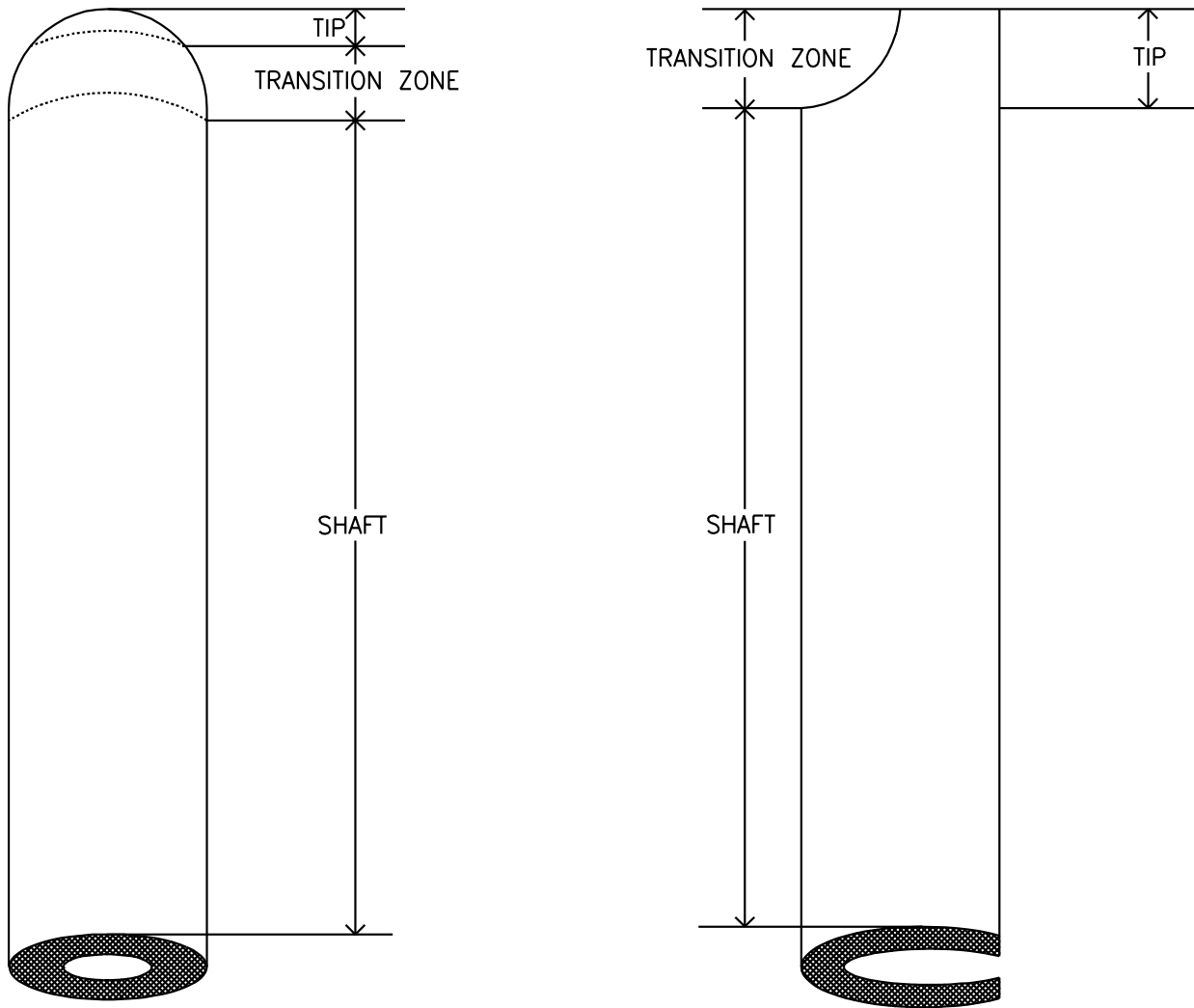

S4166

15 Assembly

15.1 General

15.1.1 Electrical contact shall be reliably maintained at any point at which a connection is made between current-carrying parts.

15.1.2 An outlet device shall have live parts protected against exposure to contact by persons when the outlet is assembled and installed as intended.

15.1.3 When internal connections exist in a multiple-outlet device, only the corresponding contacts of individual outlets shall be connected together.

15.1.4 A device having female contacts shall be constructed so that a standard attachment plug of the same configuration and with maximum length blades is capable of seating properly without exposure of the blades between the plane of the face of the plug and the plane of the rim of the female contact device.

15.1.5 Exposure (within the limits mentioned in 15.1.4) of the wide side of the blade for a distance of 0.8 mm (1/32 inch) or less (measured along the length of the blade) meets the intent of the requirement, and exposure of the narrow side of the blade meets the intent of the requirement when the exposed area is recessed for a distance not shorter than the length (measured along the blade) of the exposed area.

15.1.6 A device shall not accommodate an attachment plug other than one that is specifically intended for use with the outlet.

Exception: A travel adapter which complies with 17.5 is not required to comply with this requirement.

15.1.7 Blades shall be held securely in place. When they are mounted on a disc of insulating material separate from the rubber compound, the disc shall be:

- a) Of a material intended for the mounting of current-carrying parts,
- b) Not less than 1.6 mm (1/16 inch) thick, and
- c) Secured as intended in the plug.

15.2 Outlet separation

15.2.1 Devices having 2 or more outlets of the 2-wire, parallel-slot configuration (1-15R) shall provide for the full insertion of attachment plugs in all outlets simultaneously using plugs having the face size indicated in Figure 11.2.

15.2.2 When the outlet contacts of a device are polarized, the blades shall be polarized and the internal connections between the blades and the contacts shall maintain the polarization.

Exception: A travel adapter which complies with 17.4 is not required to comply with this requirement.

15.3 Grounding and polarization

15.3.1 A grounding outlet device (see 3.9) shall be so constructed that the grounding pin or blade of the corresponding attachment plug is not able to be inserted by hand into any outlet slot to touch the live contact.

15.3.2 A device consisting of two or more pieces shall be such that polarization is not able to be defeated by improper assembly during installation.

15.3.3 A non-grounding, non-polarized device having a 1-15R configuration, shall not accommodate an attachment plug having polarized blades to the extent that the wider (polarized) blade is able to make electrical contact with either outlet device contact. Compliance shall be determined by the test described in Improper Insertion Test, Section 35.

15.3.3 revised October 26, 2001

15.3.4 A polarized device having a 1-15R configuration shall not accommodate an attachment plug having polarized blades in other than the intended orientation to the extent that the wider (polarized) blade is able to make electrical contact with the contact of the narrower (non-polarized) slot. Compliance shall be determined by the test described in Improper Insertion Test, Section 35.

15.3.4 revised October 26, 2001

15.4 Mating and interchangeability

15.4.1 A general-use device, including any configuration illustrated in Wiring Devices – Dimensional Specifications, ANSI/NEMA WD6, or the Standard for Wiring Device Configurations, UL 1681, shall be constructed so that electrical continuity between respective and similarly marked terminals is established automatically when the mating plug and outlet device are connected together.

Exception No. 1: A 2-pole non-polarized device is not required to comply with this requirement.

Exception No. 2: A special-purpose device for use in equipment where intermixed connections do not increase the risk of fire, electric shock, injury to persons, or damage to equipment, is not required to comply with this requirement.

Exception No. 3: A travel adapter is not required to comply with this requirement. See Section 17.

15.4.2 An outlet device shall not accommodate an attachment plug other than one that is specifically intended for use with the outlet.

15.4.3 A device that is capable of making a conductive connection with a device of an established general-use design shall be constructed and rated for complete and correct interchangeability with the established design. An established general-use design is considered to include any of the following:

- a) Any of the configurations outlined in Wiring Devices – Dimensional Specifications, ANSI/NEMA WD6;
- b) Another configuration that is an American National Standard configuration; or
- c) A special-purpose configuration that is intended for use in one of the wiring systems that complies with the National Electrical Code, ANSI/NFPA 70.

15.4.4 Devices that have different electrical ratings shall not be interchangeable with one another.

Exception No. 1: A 20-A outlet device is not prohibited from accommodating a 15-A attachment plug for a single and identical voltage rating only.

Exception No. 2: A special-purpose configuration that will not mate with a standard general-use configuration is not prohibited from having multiple current and voltage ratings when the device is intended for installation in facilities where it will be serviced only by qualified personnel, and where the configuration will be used on circuits with one of the device's rated currents, voltages, and frequencies throughout the facility.

Exception No. 3: Devices that are provided with fuses and that have a lower current rating, as described in the Exception to 6.2, are not prohibited from mating with corresponding devices with the standard current rating and the identical voltage rating.

15.4.5 An outlet device having a nongrounding configuration shall not accept a grounding-type attachment plug.

Exception No. 1: The locking grounding device illustrated in Figure C3.8 and marked "Hospital Only" shall be permitted to be interchangeable with other nongrounding general-use devices which are not so marked.

Exception No. 2: A grounding adapter of the type described in 16.1 is not prohibited from accepting a grounding-type attachment plug.

15.5 Fuseholders

15.5.1 An enclosure shall be provided for the fuse or fuses in a device intended to accommodate such components.

15.5.2 A fuse enclosure shall reduce the risk of persons unintentionally contacting uninsulated live parts of the fuse and fuseholder.

15.5.3 A fuse enclosure shall confine the effects of a fuse rupture to the interior of the enclosure.

15.5.4 A device intended for use with a branch-circuit type fuse shall not be capable of accommodating a fuse or fuses that have a rating lower than the maximum rating in volts for the device. See 7.4.1.

15.5.5 In a fusible device, there shall be provision for a fuse in each ungrounded conductor, but there shall be no provision for a fuse in any other conductor.

15.5.6 The construction of a fusible device that has male pins or blades shall be such that the fuse or fuses will not be removable when the pins or blades are in a receptacle.

15.5.7 A fusible device shall not have live parts exposed to contact by persons when a fuse is being removed or replaced.

15.6 Supplementary circuitry

Added Subsection 15.6 effective April 1, 2009

15.6.1 A device provided with supplementary circuitry shall comply with all applicable requirements for that circuitry. The standards used to evaluate these devices include, but are not limited to, the following:

- a) The Standard for Transient Voltage Surge Suppressors, UL 1449.
- b) The Standard for Electromagnetic Interference Filters, UL 1283.
- c) The Standard for Secondary Protectors for Communications Circuits, UL 497A.

15.6.2 A device provided with supplementary circuitry shall provide the function of the supplementary circuitry to all outlets of the device.

Exception: A device employing two sets of line blades is not required to provide this function to all outlets of the device when the device is plainly marked to identify the blades and corresponding outlets provided with the supplementary circuit function.

15.7 Supplementary overcurrent protectors

Added Sub-section 15.7 effective April 1, 2009

15.7.1 A supplementary overcurrent protection device shall:

- a) Be of the automatic-trip manual-reset type;
- b) Be capable of clearing a fault current of not less than that indicated in Table 15.1; and
- c) Comply with the requirements in the Standard for Supplementary Protectors for Use in Electrical Equipment , UL 1077. The supplementary overcurrent protection device shall have been subjected to the Overload Test in UL 1077, tested for motor starting at 6 times the AC full load current rating. A supplementary overcurrent protection device is not prohibited from being ambient compensated.

Exception No. 1: A fuse that is capable of clearing a fault current of not less than that indicated in Table 15.1, and that complies with the requirements in the Standard for Low-Voltage Fuses - Part 14: Supplemental Fuses, UL 248-14, is not prohibited from being used as a supplementary overcurrent protection device.

Exception No. 2: A circuit breaker that complies with the requirements in the Standard for Molded-Case Circuit Breakers, Molded-Case Switches, and Circuit-Breaker Enclosures, UL 489, and is in accordance with the National Electrical Code, ANSI/NFPA-70 for branch-circuit protection, is not prohibited from being used in lieu of a supplementary overcurrent protection device.

Table 15.1
Circuit capacity of supply source

Rating (VA)	Available fault current (A)
1875 or less	1000
More than 1875 to 3750	2000
More than 3750	3500

15.7.2 A single-pole supplementary overcurrent protector shall be connected in the ungrounded side of the supply circuit. A double-pole protector shall be connected to open both ungrounded and grounded conductors (when a grounded conductor is provided) or both ungrounded conductors.

15.7.3 A supplementary overcurrent protector shall not be connected to the equipment-grounding conductor.

15.7.4 When supplementary overcurrent protection is required in accordance with Table 9.1, the rating of the overcurrent protector shall not be greater than the ampacity of:

- a) The device;
- b) The configuration of the receptacles it is to protect; or
- c) Other electrical components that carry load current, whichever is lower.

15.7.5 A device provided with supplementary overcurrent protection shall be subjected to the Supplementary Overcurrent Protector Temperature Test, Section 37.

Exception: Devices that are not required to have supplementary overcurrent protection but employ fuses shall be subjected to the Fuseholder Temperature Test, Section 34.

16 Adapters

16.1 A device whose purpose is to adapt the grounding-type attachment plug having a 5-15P configuration for use in the parallel-blade receptacle having a 1-15R configuration shall be provided with either:

- a) A grounding tab, lug, or similar device capable of being secured under the head of the outlet box cover or flush-plate mounting screw (see 16.3) and that is electrically connected to the female grounding contact in the adapter, or
- b) A male grounding pin or blade of the movable, self-restoring type. See also 7.6.1. An adapter employing a movable grounding pin or blade shall not be separable from the grounding attachment plug that is intended to be plugged into it. See 7.6.2.

16.2 The adapter mentioned in 16.1 and any other similar device that can accommodate a 3-wire grounding attachment plug having a 5-15P, 5-20P, 6-15P, 6-20P, 7-15P, 14-15P, or 14-60P configuration shall meet the Grounding Contact Tests, Section 36. See also 13.1.12.

16.3 The fixed grounding tab, lug, or similar device mentioned in 16.1:

- a) Shall be rigid enough so that the pin or blade will not touch either line blade as a result of any bending or forming,
- b) Shall be provided with a means for connection to the intended receptacle,
- c) Shall enable full tightening to the receptacle without:
 - 1) Preventing the full insertion of the adapter line blades in the receptacle, and
 - 2) Without tilting the adapter body with respect to the receptacle face, and
- d) Shall be finished to show a green color.

16.4 The blades of an adapter of the type described in 16.1 and 16.3 shall be polarized (1-15P configuration). The wide blade of the adapter shall be conductively connected to the outlet contact that is marked W in the 5-15 configuration drawing in Wiring Devices – Dimensional Specifications, ANSI/NEMA WD6.

17 Travel Adapters

17.1 The outlet face of a travel adapter employing an outlet that accepts a 2- or 3-wire, parallel-blade attachment plug of the 1-15P or 5-15P configuration shall comply with the noninterchangeability obstruction and outlet face size requirements in 11.3.1, 11.3.2, 11.4.1, and 11.4.2.

17.2 A travel adapter employing a non-ANSI standard blade or slot configuration shall comply with the dimensional requirements of the appropriate non-ANSI standard specification. A non-ANSI standard configuration is one not included in Wiring Devices – Dimensional Specifications, ANSI/NEMA WD6.

17.3 The male end of a travel adapter shall be provided with a grounding blade or pin when the outlet face employs a grounding configuration.

17.4 Polarization shall be maintained through the blades and contacts of a travel adapter. The outlet slots are to be non-polarized when the male blades or pins are non-polarized. The outlet slots are to be polarized only when the male blades or pins are polarized.

Exception: A travel adapter employing male blades or pins for use in an electrical system that does not have provision for polarization, is not prohibited from employing polarized outlet slots when it is marked in accordance with 7.6.2.

17.5 A travel adapter that allows an attachment plug to mate with an outlet device having a different current or voltage rating than that of the plug shall be marked in accordance with 7.6.1.

18 Representative Devices

18.1 Unless stated otherwise, six representative devices are to be used for each test.

18.2 Current taps and adapters are to be subjected to the appropriate tests outlined in Table 18.1.

Table 18.1
Summary of tests – Current taps and adapters

Revised Table 18.1 effective April 1, 2009

Section	Test sequences	No. of devices ^a	Details
19	Comparative Tracking Index	5	Materials to be evaluated in accordance with Exception No. 1 to 10.3.1.
20	Glow Wire	3	Materials to be evaluated in accordance with Exception No. 1 to 10.3.2.
21	High-Current Arc Resistance to Ignition	3	Materials to be evaluated in accordance with Exception No. 2 to 10.3.2
24 22 24	Dielectric Voltage Withstand Mold Stress Relief Dielectric Voltage Withstand (Repeated)	6	All devices. Devices employing thermoplastic materials. Devices subjected to Mold Stress Relief Test.

Table 18.1 Continued

Section	Test sequences	No. of devices ^a	Details
23	Moisture Absorption Resistance	3	Conducted on vulcanized fibre, fuseholders and insulating backplates. Use insulating material portion of device only.
25	Accelerated Aging	6	Materials to be evaluated in accordance with the Exception to 10.4.1.
27	Security of Blades		Devices rated 15A or less and 250 V or less.
26	Insulation Resistance	6	Devices molded of rubber or similar materials, or any material containing enough free carbon to render the material grey or black.
27	Security of Blades	6	Devices rated 15 A or less and 250 V or less that are not subjected to the Accelerated Aging Test.
28	Contact Security	6	Devices having 1-15P configuration blades only.
29	Retention of Plugs	6	Devices having a 1-15R, 5-15R, 5-20R, 6-15R, or 6-20R configuration.
30	Overload		
31	Temperature		
32	Retention of Plugs (Repeated)		Devices having a 1-15R, 5-15R, 5-20R, 6-15R, or 6-20R configuration.
33	Resistance to Arcing		Required only for devices having 1-15R, 5-15R, 5-20R, 6-15R, or 6-20R configurations not employing phenolic, urea, or melamine in the outlet face.
34	Fuseholder Temperature	6	Devices with fuseholders only.
35	Improper Insertion	12	Devices having a1-15R or 5-15R outlet face configuration only.
36	Grounding Contact	6	Devices that can accommodate a 3-wire grounding attachment plug have one of the 5-15R, 5-20R, 6-15R, 6-20R, 7-15R, 14-15R, or 15-15R configurations only.
37	Supplementary Overcurrent Protector Temperature	1	Devices employing supplementary overcurrent protectors
^a A set of representative devices is not prohibited from being used for more than one group of tests when agreeable to all concerned.			

19 Comparative Tracking Index Test

19.1 A polymeric material used for electrical (functional) insulation or enclosure of live parts tested in accordance with the Comparative Tracking Index and Comparative Tracking Performance Level Class of Electrical Insulation Materials test described in the Standard for Polymeric Materials – Short Term Property Evaluations, UL 746A, shall have a performance level class value not greater than 3.

20 Glow Wire Test

20.1 A polymeric material used for electrical (functional) insulation or enclosure of live parts is to be tested in accordance with the requirements of 20.2 in order to determine its resistance to ignition from overheated conductors caused by circuit overloads.

20.2 Devices are to be subjected to the Glow-Wire End-Product test described in the Standard for Polymeric Materials – Use in Electrical Equipment Evaluations, UL 746C, except that the tip temperature is to be 650°C (1202°F) for all devices. As a result of this test, there shall not be ignition of the insulating material during 30 seconds of application of the probe.

21 High-Current Arc Resistance to Ignition Test

21.1 A polymeric material used for electrical insulation or enclosure of live parts when tested as described in 21.2 – 21.6 shall not ignite within the number of arcs specified in Table 21.1 for the flame class of the insulating material. In addition, there shall not be dielectric breakdown caused by formation of a permanent carbon conductor path.

Exception No. 1: An insulating material used in the face of a female outlet device that has been subjected to the Resistance to Arcing Test described in Section 33, is not required to be subjected to this test.

Exception No. 2: An insulating material that has been evaluated for use in the face of a female outlet device as specified in Exception No. 1 is not prohibited from use in other applications without being subjected to this test.

Table 21.1
High-current arc resistance to ignition test arcing criteria

Table 21.1 revised October 26, 2001

Flame class	No. of arcs
HB	60
V-2, VTM-2	15
V-1, VTM-1	15
V-0, VTM-0	15

21.2 When preparing devices for test, the condition that will cause the greatest arcing near the material being tested in the device is to be simulated as follows:

- a) When the live parts are in direct contact with the polymeric material or located less than 0.8 mm (1/32 inch) from the polymeric material, the moving electrode is to be positioned on the surface of the material. The test arc is to be established between a live part acting as the fixed

**UL COPYRIGHTED MATERIAL –
NOT AUTHORIZED FOR FURTHER REPRODUCTION OR
DISTRIBUTION WITHOUT PERMISSION FROM UL**

electrode and any adjacent part where breakdown is likely to occur. For example, when the material being tested is used in the face of an attachment plug, one line blade is to be connected to the test circuit as the fixed electrode.

b) When the live parts are located at least 0.8 mm (1/32 inch) but less than 12.7 mm (1/2 inch) from the material, both the fixed and moving electrodes are to be positioned above the surface of the material at a distance equal to the minimum spacing between the live part and the material.

21.3 The test circuit is to provide test currents and test voltages equal to the current and voltage ratings of the device to be tested, but not exceeding 30 A or 240 V AC in any case. The test arc is to be established between a fixed electrode and a moving electrode consisting of a copper or stainless steel conductive probe. Each device is to be positioned with the electrodes making initial contact. The circuit is to be energized and the cyclic arcing started. The electrodes are to be drawn apart a distance not exceeding either 1.2 mm (3/64 inch) for a device rated 250 V or less and 3.2 mm (1/8 inch) for a device rated more than 250 V. The arc is to be used to attempt to ignite materials forming parts of the enclosure or to ignite materials located between the parts of different potential. The moving electrode is to be used to break through insulation, create arc tracking or create a carbon build-up across the surface of the insulating material at a rate of 30 to 40 arc separations per minute.

21.3 revised April 30, 2003

21.4 Immediately following the completion of the arcing portion of the test, the device is to be subjected to a 50 to 60 Hz essentially sinusoidal potential applied as described in 21.5 between live parts of opposite polarity and between live parts and dead metal parts. The test potential is to equal twice the rated voltage of the device plus 1000 V.

21.5 The device is to be tested by means of a 500 VA or larger capacity transformer whose output voltage is essentially sinusoidal and can be varied. The applied potential is to be increased from zero until the required test level is reached, and is to be held at that level for one minute. The increase in the applied potential is to be at a uniform rate and as rapid as is consistent with its value being correctly indicated by a voltmeter.

21.6 When the output of the test-equipment transformer is less than 500 volt-amperes, the equipment is to include a voltmeter in the output circuit to indicate the test potential directly.

22 Mold Stress Relief Test

22.1 As a result of temperature conditioning specified in 22.2, there shall not be any warpage, shrinkage or other distortion that results in any of the following:

- a) Making uninsulated live parts or internal wiring accessible to contact by the probe illustrated in Figure 11.1.
- b) Defeating the integrity of the enclosure so that intended mechanical protection is not afforded to the internal parts of the device.
- c) Interference with the operation, function or installation of the device. The outlet slot openings of a female device shall be capable of receiving a fully inserted attachment plug of the intended configuration.
- d) A reduction of spacings between uninsulated live parts of opposite polarity, uninsulated live parts and accessible dead or grounded metal below the minimum required values.
- e) Any other evidence of damage that could increase the risk of fire or electric shock.

Exception: Devices employing only thermosetting materials are not required to be subjected to this test.

22.2 The devices are to be placed in a circulating air oven maintained at a temperature of 70°C (158°F) for 7 hours. The devices are to be removed from the oven and allowed to cool to room temperature before determining compliance.

22.3 Immediately following the completion of this test, the devices are to be subjected to a repeated Dielectric Withstand Test as described in Section 24. The devices are not required to be subjected to the humidity conditioning described in 24.3.

23 Moisture Absorption Resistance Test

23.1 Moisture-resistant insulating materials shall not absorb more than 6% of water by mass.

23.2 The material is to be:

- a) Dried at 105 ±5°C for 1 hour;
- b) Weighed (W_1);
- c) Immersed in distilled water at 23 ±1°C for 24 hours;
- d) Removed from the distilled water and the excess surface moisture wiped off; and
- e) Reweighed (W_2).

The moisture absorbed by the material is to be calculated as:

$$\frac{W_2 - W_1}{W_1} \times 100\%$$

Exception: A material tested in accordance with the Test method for Water Absorption of Plastics [ASTM D 570-81(1988)] described in the Standard for Polymeric Materials – Short Term Property Evaluations, UL 746A, is not required to be tested.

24 Dielectric Withstand Test

24.1 A device not provided with a means for fixed attachment to a receptacle shall be capable of withstanding the application of an ac potential of 1000 V plus 2 times the rated voltage applied for a period of one minute between live parts of opposite polarity and between live parts and grounding or dead metal parts.

24.2 A device provided with a means for fixed attachment to a receptacle shall be capable of withstanding the application of an ac potential for one minute between live parts of opposite polarity and between live parts and grounding or dead metal parts immediately following the humidity conditioning described in 24.3. The test potential is to be 2000 V for devices rated 300 V or less and 3000 V for devices rated greater than 300 V.

Exception: Devices employing polymeric materials consisting wholly of thermoset, thermoplastic, or elastomeric materials are not required to be subjected to the humidity conditioning.

24.3 Mating attachment plugs with solid blades are to be inserted into the contact openings of three of the six devices. The devices are then to be placed into an environmental chamber and subjected to the following conditions:

- a) 4 hours at a temperature of $75 \pm 1^\circ\text{C}$ ($167 \pm 1.8^\circ\text{F}$) at a relative humidity of 92 ± 3 percent.
- b) 16 hours at a temperature of $75 \pm 1^\circ\text{C}$ ($167 \pm 1.8^\circ\text{F}$) at a relative humidity 40 ± 3 percent.
- c) 4 hours at a temperature of $30 \pm 1^\circ\text{C}$ ($86 \pm 1.8^\circ\text{F}$) at a relative humidity of 60 ± 3 percent.

24.4 The device to be tested by means of a 500 VA or larger capacity transformer whose output voltage is essentially sinusoidal and is able to be varied. The applied potential is to be increased from zero until the required test level is reached, and is to be held at that level for one minute. The increase in the applied potential is to be at a uniform rate and as rapid as is consistent with its value being correctly indicated by a voltmeter.

24.5 When the output of the test-equipment transformer is less than 500 volt-amperes, the equipment is to include a voltmeter in the output circuit to indicate the test potential directly.

24.6 The mating attachment plugs used in 24.3 are to be capable of withstanding the application of a 2500 V potential for devices rated 300 V or less and a 3500 V potential for devices rated greater than 300 V.

25 Accelerated Aging Tests

25.1 General

25.1.1 A device employing one of the insulating materials tabulated in the Exception to 10.4.1 in an insulation or enclosure application shall be subjected to one of the following tests as applicable.

25.2 Rubber, EPDM, and TEE compounds

25.2.1 A device employing a rubber, EPDM, or TEE compound shall not show any apparent deterioration and no greater change in hardness than ten units as a result of the test described in 25.2.2 – 25.2.4.

25.2.2 When possible, a complete device is to be used for this test. The hardness of the material is to be determined as the average of five readings with an appropriate gauge, such as the Rex hardness gauge or the Shore durometer. The device is to be placed in a full-draft air-circulating oven for 70 hours at a temperature of 100°C (212°F). The device is to be allowed to rest at room temperature for four or more hours after removal from the oven. The hardness is to be determined again as the average of five readings. The difference between the average original hardness reading and the average reading taken after exposure is the change in hardness.

25.2.3 Following the accelerated aging conditioning described in 25.2.2, a device having male blades supported by the material under test shall be capable of withstanding the Security of Blades Test, Section 27.

25.2.4 The accelerated-aging tests described in 25.2.1 – 25.2.3 are to be made on each color of material and on each basic rubber, EPDM, or TEE material employed for the device.

25.3 PVC compounds and copolymers

25.3.1 A device employing polyvinyl chloride or one of its copolymers shall not show any cracks, discoloration, or other visible signs of deterioration of the molding material as a result of this test.

25.3.2 The device is to be placed in a full-draft air-circulating oven for 96 hours at a temperature of 100°C (212°F). The device is to be allowed to rest at room temperature for at least one hour after removal from the oven. Warping or distortion of the device housing that occurs as a result of the oven conditioning shall not be considered to be a sign of deterioration.

26 Insulation Resistance Test

26.1 When determined as described in this Section, the insulation resistance shall not be less than 100 megohms between:

- a) Live parts of opposite polarity;
- b) Live parts and dead-metal parts that are exposed to contact by persons or that are capable of being grounded in service; and
- c) Live parts and any surface of insulating material that is exposed to contact by persons or that are capable of being in contact with ground in service.

26.2 The insulation resistance measurement is to be made on rubber and similar materials of any color. Other materials are to be tested when they contain free carbon in such quantity that it renders the material grey or black.

26.3 To determine compliance with the requirement in 26.1, the insulation resistance is to be measured by a magneto megohmmeter that has an open-circuit output of 500 V or by equivalent equipment.

26.4 The use of a megohmmeter between metal parts requires no special clarification or instruction. However, in measuring insulation resistance to the surface of an insulating material, an electrode is to be applied to the insulating material as described in 26.5.

26.5 A quantity of No. 7 lead or nickel-plated lead drop shot (approximate diameter 2.5 mm or 0.10 inch) is to be placed in a container that is open at the top. After cord holes or other openings through which the shot could enter have been carefully plugged with a high-resistance insulating material, the device is to be immersed in the shot so that the shot serves as an electrode in contact with the surface to which the test is to be applied.

26.6 All rubber parts are to be kept for at least 48 hours at room temperature before being subjected to the test mentioned in 26.3.

27 Security of Blades Test

27.1 The blades and pins of a device rated 15 A or less, and 250 V or less, shall be capable of withstanding a pull of 89 N (20 lb) for 2 minutes without loosening. In a device of nonrigid construction (when, for example, a soft, molded material is used) a residual displacement of either blade shall not be more than 2 mm (0.079 inch) measured 2 minutes after the removal of the weight. See 25.2.3.

27.2 The device is to be supported on a horizontal steel plate with the blades, pins, or both projecting downward through a single hole with the smallest dimension that will permit the blades, pins, or both to pass through it.

27.3 A weight that exerts a force of 89 N (20 lb) is to be supported by each blade or pin in succession. The pull is to be gradually applied.

27.4 When parallel blades are involved so that the secureness of each blade is dependent to some degree on the assembly of the other blade, the two blades are also to be tested together. A rigid pin is to be placed in holes drilled in the blades when not provided, and a weight that exerts a force of 89 N (20 lb) is to be placed on the rigid pin, centered between the blades.

28 Contact Security Test

28.1 The female contacts of a device shall remain inaccessible to contact after the device has been tested as described in this Section.

28.2 A device having blades for connection to 2-pole, 2-wire outlets rated 15 A, 125 V is to be rigidly supported in the blades-up position. The device is to be positioned and supported so as not to restrict possible displacement of the female contacts, breakage of the enclosure, or both. Each blade, in turn, is to be individually subjected to a force of 133 N (30 lbf) applied gradually along the longitudinal axis of the blade in a direction towards the plug face. The 133 N (30 lbf) is to be maintained for a period of 1 minute.

28.3 The same devices are to be retested as described in 28.2 subjecting both blades, in combination, to a single applied force of 178 N (40 lbf) for a period of 1 minute.

29 Retention of Plugs Test

29.1 The contacts of a 1-15R, 5-15R, 5-20R, 6-15R or 6-20R configuration device shall retain an attachment plug so that a force greater than 13 N (3 lbf) is required to withdraw the plug when tested as described in this Section.

Exception: A device that has provision for locking the plug in place after the blades have been inserted in the female contacts (such as a rotating collar) is not required to be subjected to this test.

29.2 Each of the six devices is to be subjected to ten conditioning cycles of insertion and withdrawal of a standard solid-blade attachment plug that has American National Standard detent holes in accordance with Wiring Devices – Dimensional Specifications, ANSI/NEMA WD6 in rigidly mounted blades, following which the plug is to be fully reinserted into the device. The mating plugs are to have the configuration indicated in Table 29.1. A pull of 13 N (3 lbf) in a direction perpendicular to the plane of the face of the outlet device and tending to withdraw the plug from the device is then to be applied to the plug for 1 minute. The displacement of the plug shall not be greater than 2 mm (0.079 inch).

Table 29.1
Mating plug configurations for plug retention

Table 29.1 revised October 26, 2001

Device under test	Mating plug	No. of devices tested
1-15R	1-15P	6
5-15R	1-15P	6
5-20R	1-15P	3
	5-20P ^a	3
6-15R	2-15P	6
6-20R	2-15P	3
	6-20P ^a	3

^a Shall have the ground blade removed.

29.3 For multi-configuration travel adapters, separate sets of six representative adapters are to be tested. The number of sets is to be determined by the number of attachment plug configurations that are capable of being used by the representative travel adapter. Each set of six representative multi-configuration travel adapters is to be tested using a different attachment plug configuration considered representative of those that are identified for use with the adapter.

30 Overload Test

30.1 A device shall be capable of performing as intended when subjected to the overload test as described in this Section. There shall not be any electrical or mechanical failure of the device, opening of a line or grounding fuse, welding of the contacts, nor burning or pitting of the contacts affecting the intended function of the device.

No Text on This Page

***UL COPYRIGHTED MATERIAL –
NOT AUTHORIZED FOR FURTHER REPRODUCTION OR
DISTRIBUTION WITHOUT PERMISSION FROM UL***

Exception: A device that is intended for disconnecting use only and not for current interruption, is not required to be subjected to this test. See also 6.4 and 7.5.1.

30.2 The device is to be mounted to represent service conditions. The frame and enclosure, when any, are to be electrically positive with respect to the nearest arcing point of the device.

30.3 The fuse in the grounding conductor is to be:

- a) A 15 A fuse when the device being tested is rated 30 A or less; or
- b) A 30 A fuse when the device being tested is rated more than 30 A.

The fuse in the test circuit is to have the next higher standard fuse rating than the value of the test current.

30.4 The potential of the test circuit is to be from 95 to 105 percent of the rating of the device in volts. Devices rated 250 V are to be tested on circuits with a potential to ground of 125 V. Devices having other voltage ratings are to be tested on circuits involving full rated potential to ground, except for multi-phase rated devices which are to be tested on circuits consistent with their voltage ratings (for example, a 120/208 V, 3-phase device, is to be tested on a circuit involving 120 V to ground). Testing using a 60 Hz supply voltage is representative of testing using a higher frequency supply voltage not exceeding 400 Hz.

30.5 Each of six devices is to be tested by machine or manually by inserting and withdrawing an attachment plug having rigidly secured solid blades that are connected through a flexible cord to a load. For devices with a 1-15R, 5-15R, 5-20R, 6-15R or 6-20R configuration, the mating plugs shall have the configurations specified in Table 30.1. When an equipment-grounding connection is provided in the device being tested, a grounding-type attachment plug is to be used and the grounding blade of the plug connected to the grounding contact of the device being tested. The grounding contact is then to be grounded through a fuse as specified in 30.3.

Table 30.1
Mating plug configurations for overload testing

Device under test	Mating plug	No. of devices tested
1-15R	1-15P	6
5-15R	5-15P	6
5-20R	5-15P	3
	5-20P	3
6-15R	6-15P	6
6-20R	6-15P	3
	6-20P	3

30.6 For a device rated 20 A or less, the test machine is to withdraw and insert an unrestricted attachment plug with an average velocity of 760 ± 75 mm/s (30 ± 3 inches/s) in each direction during a 64 mm (2-1/2 inch) stroke measured from the fully inserted position. The velocity is to be determined without the outlet device installed on the machine to eliminate restrictions on the plug motion.

30.7 For a device rated more than 20 A the test machine unrestricted plug velocity and stroke length are to be adjusted as necessary to obtain the maximum mating time required in 30.8.

30.8 The device is then to make and break the required test load for 50 cycles of operation at a rate no faster than 10 cycles per minute. The blade of the attachment plug is to mate with the female contact of the device for no more than 1 second for straight-blade devices, and 3 seconds for locking devices during each cycle. For locking devices, each cycle of operation is to include rotation of the test plug to the full lock position after insertion, and back to the unlocked position before withdrawal.

30.9 The test current shall be 150 percent of the rated current of the device. Devices rated AC Only are to be tested using alternating current with the power factor of the load to be from 0.75 – 0.80. All other devices are to be tested on direct current with a resistive load.

30.10 Testing of a device that has a dual voltage rating and a dual current rating is to be performed at the maximum rating in volts and with 150 percent of the rated current that corresponds to the maximum voltage rating.

Exception: A test on alternating current is not required when equivalent results have been obtained from a direct potential that is equal to or greater than the alternating-potential rating.

30.11 Blades or contacts are not to be adjusted, lubricated, or otherwise conditioned before or during the test. The attachment plug used for the test is not prohibited from being changed after 50 cycles.

30.12 When a device is found to not perform as intended when subjected to the machine testing described in 30.5 or 30.6, referee tests are capable of being conducted manually under conditions similar to those described in 30.5 or 30.6.

30.13 For multi-configuration travel adapters, separate sets of six representative adapters are to be tested. The number of sets is to be determined by the number of attachment plug configurations that are capable of being used by the representative travel adapter. Each set of six representative multi-configuration travel adapters is to be tested using a different attachment plug configuration considered representative of those that are identified for use with the adapter. The test current used for each set of representative adapters is to be based upon the current rating associated with the configuration of the attachment plug used in the test. The test voltage shall equal the voltage rating associated with the configuration of the male blades of the adapter. See 6.5.

30.14 A supplementary overcurrent protector provided as part of a device shall be short-circuited by means of a solid copper conductor sized in accordance with the National Electrical Code, ANSI/NFPA-70, based on the device rating, and soldered in place prior to this test.

Added 30.14 effective April 1, 2009

31 Temperature Test

31.1 The temperature rise of a device measured at the points described in 31.2 shall not be more than 30°C (54°F) when the device is carrying its maximum rated current.

31.2 Temperatures are to be measured by means of thermocouples attached to the blades of the mated attachment plug as close as possible to the face of the device.

31.3 The temperature test is to be made following the overload test on the device and is to continue for stabilized temperatures are attained. A temperature is considered to be stabilized when three consecutive readings taken at 5 minute intervals indicate no further rise above the ambient temperature.

31.4 The generation of heat from sources other than the female contacts is to be minimized as much as possible. Type RH or Type TW lead-in wires no more than 300 mm (12 inches) long are to be soldered to the blades.

31.5 The contacts of the device being tested are to be connected together by means of a mated attachment plug. For devices with a 1-15R, 5-15R, 5-20R, 6-15R, or 6-20R configuration, the mating plugs shall have the configurations specified in Table 31.1. The plug is to have rigidly attached blades, and the terminals of the plug are to be short-circuited by means of the shortest feasible lengths of Type TW or Type RH wire or the appropriate flexible cord as described in 31.4.

Table 31.1
Mating plug configurations for temperature testing

Device under test	Mating plug	No. of devices tested
1-15R	1-15P	6
5-15R	5-15P	6
5-20R	5-15P	3
	5-20P	3
6-15R	6-15P	6
6-20R	6-15P	3
	6-20P	3

31.6 For multi-configuration travel adapters, separate sets of six representative adapters are to be tested. The number of sets is to be determined by the number of attachment plug configurations that are capable of being used by the representative travel adapter. Each set of six representative multi-configuration travel adapters is to be tested using a different attachment plug configuration considered representative of those that are identified for use with the adapter. The test current used for each set of representative adapters is to be based upon the current rating associated with the configuration of the attachment plug used in the test. See 6.5.

31.7 Temperature readings are to be obtained by means of thermocouples consisting of Nos. 28 – 32 AWG (0.08 – 0.032 mm²) iron and constantan wires. It is a common practice to employ thermocouples consisting of No. 30 AWG (0.05 mm²) iron and constantan wires with a potentiometer type of indicating instrument. This equipment will be used when a referee measurement of temperature is required.

31.8 A supplementary overcurrent protector provided as part of a device shall be short-circuited by means of a solid copper conductor sized in accordance with the National Electrical Code, ANSI/NFPA-70, based on the device rating, and soldered in place prior to this test.

Added 31.8 effective April 1, 2009

32 Retention of Plugs Test (Repeated)

32.1 General

32.1.1 After completion of the Overload Test, Section 30, and the Temperature Test, Section 31, the contacts of a 1-15R, 5-15R, 5-20R, 6-15R or 6-20R configuration device shall retain an attachment plug so that when tested as described in this Section:

- a) A force greater than 13 N (3 lbf) is required to withdraw the plug, and
- b) A force of 67 N (15 lbf) is capable of withdrawing the plug.

Exception: A device that has provision for locking the plug in place after the blades have been inserted in the female contacts (such as a rotating collar) is not required to be subjected to this test.

32.2 Plug retention

32.2.1 Each of six devices is to be tested. A standard solid-blade attachment plug that has American National Standard detent holes in accordance with Wiring Devices – Dimensional Specifications, ANSI/NEMA WD6 in rigidly mounted blades is to be fully inserted into the device. The test plugs are to have the configuration specified in Table 32.1. A pull of 13 N (3 lbf) in a direction perpendicular to the plane of the face of the outlet device and tending to withdraw the plug from the device is then to be applied to the plug for 1 minute. The displacement of the plug shall not be greater than 2 mm (0.079 inch).

Table 32.1
Mating plug configurations for plug retention

Table 32.1 revised October 26, 2001

Device under test	Mating plug	No. of devices tested
1-15R	1-15P	6
5-15R	1-15P	6
5-20R	1-15P	3
	5-20P ^a	3
6-15R	2-15P	6
6-20R	2-15P	3
	6-20P ^a	3

^a Shall have the ground blade removed.

**UL COPYRIGHTED MATERIAL –
NOT AUTHORIZED FOR FURTHER REPRODUCTION OR
DISTRIBUTION WITHOUT PERMISSION FROM UL**

32.3 Plug withdrawal

32.3.1 Each of six devices is to be tested. Following the application of the 13 N (3 lbf), the pull is to be increased to 67 N (15 lbf), using test plugs having the configuration specified in Table 32.2, and the plug shall be withdrawn by the force.

Table 32.2
Mating plug configurations for plug withdrawal

Device under test	Mating plug	No. of devices tested
1-15R	1-15P	6
5-15R	5-15P	6
5-20R	5-15P	3
	5-20P	3
6-15R	6-15P	6
6-20R	6-15P	3
	6-20P	3

33 Resistance to Arcing Test

33.1 When a material is used in the construction of the face of a device having female contacts in a way that the material is likely to be exposed to arcing while in service, the devices that were subjected to 50 cycles of operation as described in the Overload Test, Section 30, shall perform as intended when subjected to an additional 200 cycles of operation under the overload-test conditions following the temperature test and the repetition of the retention-of-plugs and gripping tests. There shall not be any indication of electrical tracking, formation of a permanent carbon conductive path or ignition of the material. The attachment plug used for this test is not prohibited from being changed after every 50 cycles of operation.

Exception: This test is not required for devices employing phenolic, urea, or melamine in the outlet face.

33.2 Alternatively, one set of devices is to be subjected to the 50 cycles of operation as described in the Overload Test, Section 30, followed by the Temperature Test, Section 31, and then, to determine resistance to arcing, a second, previously untested set of devices is to be subjected to 250 cycles of operation under the overload-test conditions.

33.3 For multi-configuration travel adapters, separate sets of six representative adapters are to be tested. The number of sets is to be determined by the number of attachment plug configurations that are capable of being used by the representative travel adapter. Each set of six representative multi-configuration travel adapters is to be tested using a different attachment plug configuration considered representative of those that are identified for use with the adapter. The test current used for each set of representative adapters is to be based upon the current rating associated with the configuration of the attachment plug used in the test. The test voltage shall equal the voltage rating associated with the configuration of the male blades of the adapter. See 6.5

33.4 A supplementary overcurrent protector provided as part of a device shall be short-circuited by means of a solid copper conductor sized in accordance with the National Electrical Code, ANSI/NFPA-70, based on the device rating, and soldered in place prior to this test.

Added 33.4 effective April 1, 2009

34 Fuseholder Temperature Test

34.1 When tested as described in this Section, the temperature rise of a device incorporating a fuseholder shall not exceed the following:

- a) 30°C (54°F) on the fuse clips when tested with a dummy fuse;
- b) 85°C (153°F) on the fuse clips when tested with a live fuse; and
- c) The relative thermal index of the surrounding insulating material, minus an assumed ambient of 25°C (77°F), at any time (see 34.7).

34.2 The test is to be conducted on a set of six previously untested devices. The test is to be conducted with either a live fuse or a dummy fuse (see 34.6 and 34.7).

Exception: Testing in conjunction with the Temperature Test, Section 31, meets the intent of the requirement when agreeable to all concerned.

34.3 The devices are to be wired in a series circuit as described in the Temperature Test, Section 31.

34.4 Temperatures are to be measured by means of thermocouples attached to the fuse clips and the insulating material of the device body in proximity to the fuseholder.

34.5 The test is to continue for at least 4 hours even though stabilized temperatures are capable of being attained in a somewhat shorter interval of time. A temperature is stabilized when three consecutive readings, taken at 5 minute intervals, indicate no further rise above the ambient temperature.

34.6 When the test is to be conducted with a live fuse, the devices are to be tested with the largest ampere-rated fuse intended for use with the device installed and subjected to a test current equal to the maximum fuse ampere rating.

34.7 When the test is to be conducted with a dummy fuse, the devices are to be subjected to a test current equal to the maximum ampere rating of the intended fuse. The dummy fuse size for devices incorporating Class CC, G, H, J, K, or R is to be as specified in the Standard for Fuseholders, UL 512. The dummy fuse size for devices employing miscellaneous, miniature and micro fuses is to be as indicated in Table 34.1. To represent the heating of a live fuse, 20°C (36°F) is to be added to the recorded temperature rise on the wiring terminals, cord connections, and surrounding insulating materials.

Table 34.1
Nominal dimensions of dummy fuses for miscellaneous, miniature and micro fuses

Size of fuse	Dimensions		
	Outside diameter	Wall thickness	Length
5 x 20 mm (0.2 x 0.8 inches)	5 mm (0.2 inches)	1.2 mm (0.047 inches)	20 mm (0.8 inches)
6.4 x 31.8 mm (1/4 x 1-1/4 inches)	6.4 mm (0.25 inches)	1.2 mm (0.047 inches)	31.8 mm (1-1/4 inches)

34.8 The thermocouples are to consist of Nos. 28 – 32 AWG (0.08 – 0.032 mm²) iron and constantan wires. It is a common practice to employ thermocouples consisting of No. 30 AWG (0.05 mm²) iron and constantan wires with a potentiometer type of indicating instrument. This equipment will be used when a referee measurement of temperature is required.

35 Improper Insertion Test

35.1 To determine compliance with 15.3.3 and 15.3.4, a device shall obstruct the attempted insertion of the test blades illustrated in Figure 35.1, when tested as described in 35.2 and 35.3.

35.2 Each of 12 devices is to be tested while being supported on a flat steel plate. Rigid spacing materials are capable of being used to support a device that because of its shape does not lie flat on the steel plate, provided that by doing so, pressure is not exerted against the device that will influence test results. The test blades shall be supported and centered above the non-polarized contact slot of the device being tested. Each contact slot of a non-polarized device is to be tested separately.

35.3 Each test blade is to be inserted into the non-polarized contact slot with a force that is to be gradually increased from zero to 156 N (35 lbf). The force is to be maintained for one minute. Six devices are to be tested using test blade 1, and six using test blade 2. In each case, the test blades shall be obstructed to the extent that they do not make electrical contact with the device contact relating to the non-polarized slot.

No Text on This Page

***UL COPYRIGHTED MATERIAL –
NOT AUTHORIZED FOR FURTHER REPRODUCTION OR
DISTRIBUTION WITHOUT PERMISSION FROM UL***

Figure 35.1
Improper insertion test blades

TEST BLADE 1

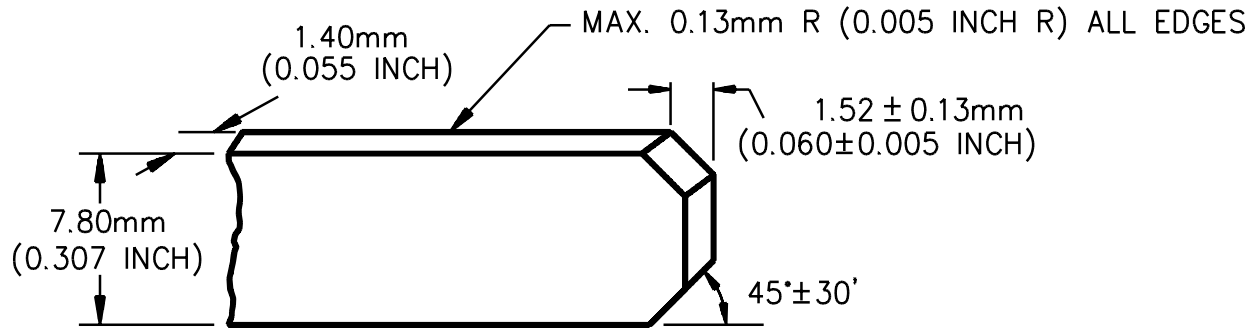

MATERIAL: TOOL STEEL

TEST BLADE 2

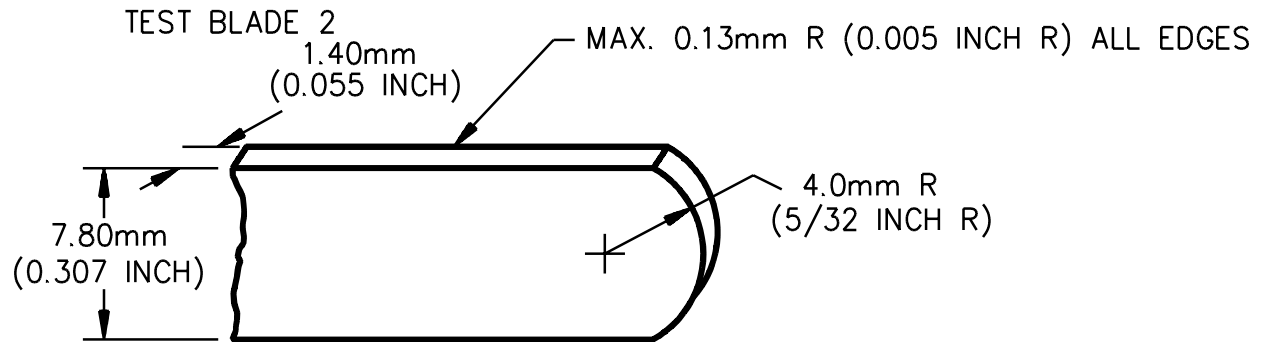

SB1889A

MATERIAL: TOOL STEEL

36 Grounding Contact Tests

36.1 General

36.1.1 Devices that can accommodate a 3-wire grounding attachment plug having one of the 5-15P, 5-20P, 6-15P, 6-20P, 7-15P, 14-15P, or 15-15P configurations [U-shaped grounding pin clearance opening intended to receive an 4.67 – 4.83 by 21.41 mm (0.184 – 0.190 by 0.843 inch) maximum attachment plug grounding pin] are to be subjected to the tests indicated in this Section.

36.1.2 Devices that are provided with a means for fixed attachment to a receptacle shall be subjected to the conditioning, continuity check, and grounding pin retention requirements described in 36.2 – 36.4.

36.1.3 Devices that are not provided with a means for fixed attachment to a receptacle shall be subjected only to the continuity check and grounding pin retention requirements described in 36.3 and 36.4.

36.2 Conditioning

36.2.1 Six previously untested devices are to be used. Each device is to be mouted on a flush receptacle as intended, with its face in a vertical plane. A nonmetallic faceplate is to be installed when intended. A solid No. 14 AWG (2.1 mm²) copper conductor is to be connected to the receptacle grounding material.

Exception: A grounding adapter that is provided with a tab for fixed attachment to a receptacle is not prohibited from being supported in a test jig or fixture that does not restrict possible deformation of the grounding contact while subjected to the conditioning described in 36.2.2. Upon completion of the conditioning, the adapter is to be assembled onto a flush plate as noted above before conducting the grounding continuity check and grounding pin retention test described in 36.3 and 36.4.

36.2.2 With the device oriented to create the maximum contact displacement (possible distortion of contact affecting its contact ability), the test pin A, Figure 36.1, is to be fully inserted in the grounding contact of the device under test. A 2.27 kg (5 lb) weight is to be gradually suspended from the test pin 152 mm (6 inches) from the face of the device. The weight is to be applied for 1 minute, following which, the weight is to be removed. The application of the weight is to be repeated with the device rotated 90, 180 and 270 degrees for a total of four applications. Usually the test is started with the grounding pin opening directly above, below or on either side of the line slots. The adapters, current taps, and similar devices are to remain in a vertical plane during each of the 1 minute contact conditioning periods.

36.2.3 As a result of this conditioning, there shall not be any breakage of the outlet face of the device that would expose live parts to contact by a 1.6 mm (1/16 inch) diameter rod. In addition, there shall not be any breakage or distortion of the insulating body of the device that results in reduction of electrical spacings to values less than those required for the device. The conditioning pin shall remain in place without extraneous support for the required 1 minute in each position.

Exception: A device made of one of the materials described in the Exception to 10.4.1 is not required to support the conditioning pin without extraneous support.

36.3 Continuity

36.3.1 A current tap or adapter that is provided with a means for fixed attachment to a receptacle is to remain assembled to the receptacle and flush plate as described in 36.2.1 during the continuity check. Each device is then to be tested for electrical continuity between the receptacle grounding terminal and the fully inserted test pin B, Figure 36.2. There shall not be a loss of contact while the pin is moved by

**Figure 36.1
Test pin A**

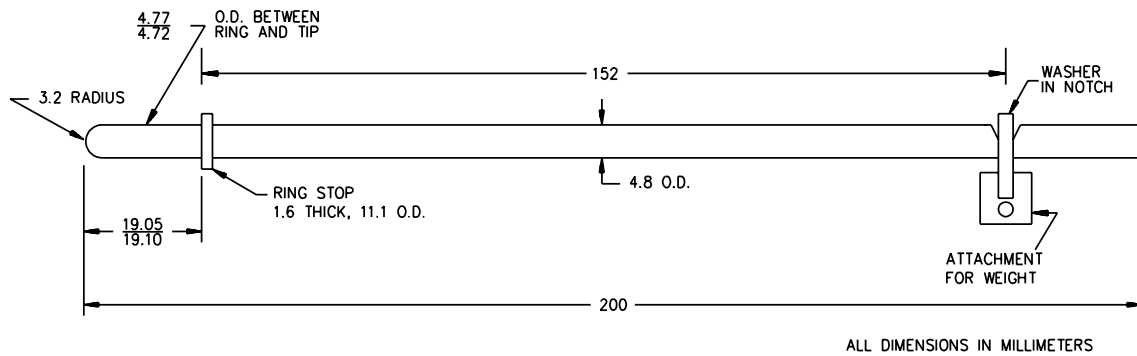

Pin material – tool steel, Rockwell Hardness C58 to C60

mm	1.6	3.2	4.8	4.72	4.77	11.1	19.05	19.10	152	200
inch	1/16	1/8	3/16	0.186	0.188	7/16	0.750	0.752	6	7-7/8

SB1609C

hand, without exerting undue pressure, so as to touch all internal walls and surfaces. The stop ring of the pin shall remain continuously in contact with the face of the device. An indicating device, such as an ohmmeter, a battery-and-buzzer combination, or similar device, is to be used.

Exception: A grounding adapter that is provided with a tab for fixed attachment to a receptacle that was supported in a test jig or fixture in accordance with the Exception to 36.2.1 is to be assembled onto a receptacle and flush plate as noted in 36.2.1 before conducting the grounding continuity check.

36.3.2 A current tap or adapter that is not provided with a means for fixed attachment to a receptacle is to be supported in a test jig or fixture that does not restrict possible deformation of the grounding contact while checking continuity. Each device is then to be tested for electrical continuity between the grounding pin and the fully inserted test pin B, Figure 36.2. There shall not be a loss of contact while the pin is moved by hand, without exerting undue pressure, so as to touch all internal walls and surfaces. The stop ring of the pin shall remain continuously in contact with the face of the device. An indicating device, such as an ohmmeter, a battery-and-buzzer combination, or similar device, is to be used.

36.4 Retention

36.4.1 Each device is then to be positioned facing down in a horizontal position. The device under test shall support the 57 and 113 g (2 and 4 oz.) grounding pin illustrated in Figures 36.3 and 36.4, for 1 minute each when fully inserted in the grounding pin opening. The displacement of the grounding pin shall not be greater than 2 mm (0.079 inches).

**Figure 36.2
Test pin B**

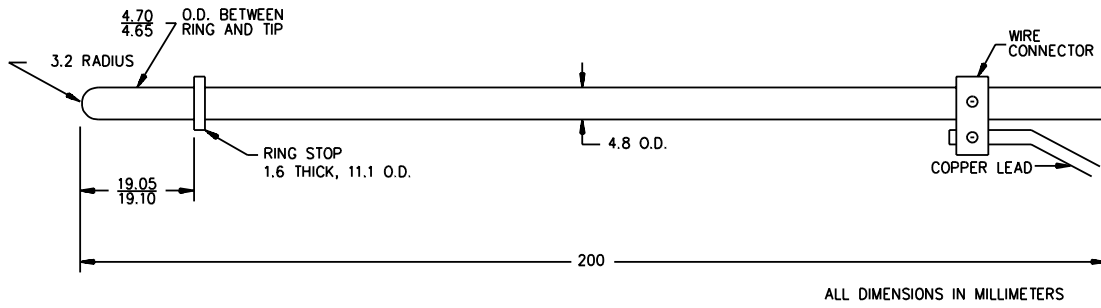

Pin material – solid brass rod

mm	1.6	3.2	4.8	4.65	4.7	11.1	19.05	19.10	200
inch	1/16	1/8	3/16	0.183	0.185	7/16	0.750	0.752	7-7/8

SB1610B

Figure 36.3
57 g (2 oz) ground pin

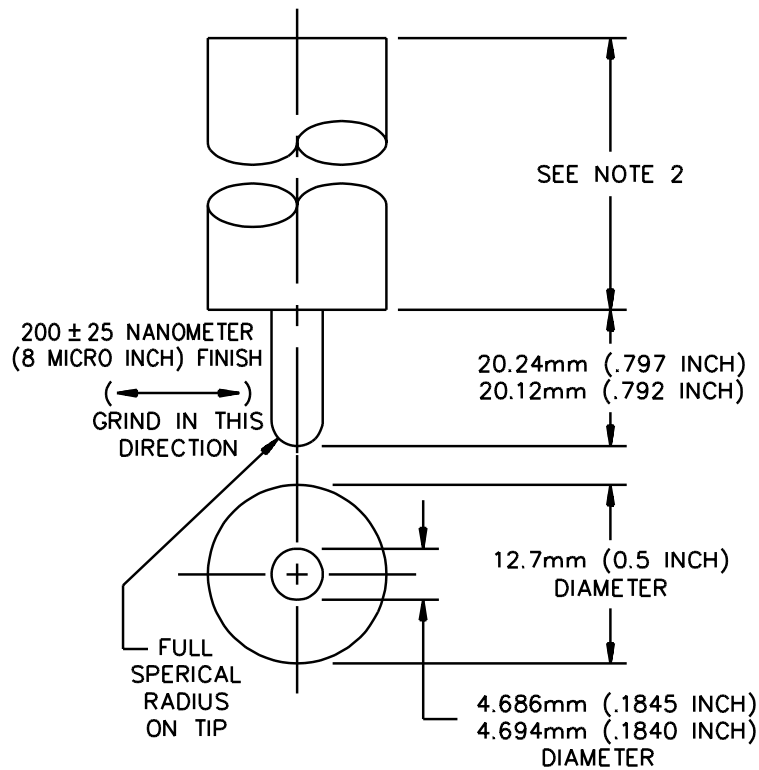

Material: Pin-Steel, Rockwell Hardness C58 to C60.
Handle - cold rolled steel

NOTES

- 1) The ground pin is to be fastened to handle in rigid manner.
- 2) Length not specified. Total tool weight 57 g (2 oz).
- 3) Axis of blade and axis of handle must have combined concentricity and axial alignment of 0.006 maximum at tip of pin.

mm	4.694	4.686	20.12	20.24	12.7
inch	0.1840	0.1845	0.792	0.797	0.5
nanometer	200 ± 25				
microinch	8				

SB0704D

**UL COPYRIGHTED MATERIAL –
NOT AUTHORIZED FOR FURTHER REPRODUCTION OR
DISTRIBUTION WITHOUT PERMISSION FROM UL**

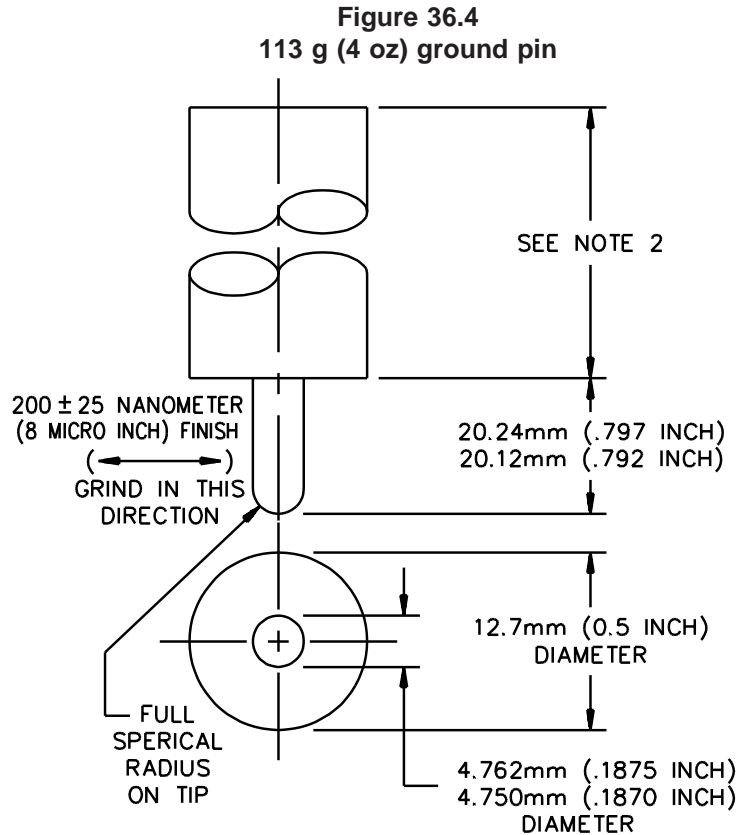

Material: Pin—Steel, Rockwell Hardness C58 to C60.
Handle — cold rolled steel

NOTES

- 1) The ground pin is to be fastened to handle in rigid manner.
- 2) Length not specified. Total tool weight 113 g (4 oz).
- 3) Axis of blade and axis of handle must have combined concentricity and axial alignment of 0.006 maximum at tip of pin.

mm	4.750	4.762	20.12	20.24	12.7
inch	0.1870	0.1875	0.792	0.797	0.5
nanometer	200 ± 25				
microinch	8				

SB1622D

**UL COPYRIGHTED MATERIAL –
NOT AUTHORIZED FOR FURTHER REPRODUCTION OR
DISTRIBUTION WITHOUT PERMISSION FROM UL**

37 Supplementary Overcurrent Protector Temperature Test

Added Section 37 effective April 1, 2009

37.1 When tested as described in 37.2 - 37.7, the temperature at any location on a device employing supplementary overcurrent protection shall not exceed the temperatures shown in Table 37.1.

Table 37.1
Maximum temperatures

Materials and components	°C	°F
1. Varnished-cloth insulation	85	185
2. Fiber, wood, and other similar electrical insulation	90	194
3. Phenolic composition employed as electrical insulation or as a part whose malfunction would result in a risk of fire or electric shock	150 ^a	302 ^a
4. Insulated wires and cables	60 ^a	140 ^a
5. On the surface of a capacitor casing:		
Electrolytic	65 ^b	149 ^b
Other types	90 ^b	194 ^b
6. Receptacle contacts	55	135
7. Fuses other than Class CC, G, J, T	90	194
8. Fuses Class CC, G, J, T	110	230

NOTE - See 37.3.

^a The limitations on phenolic composition and on wire insulations do not apply to compounds that have been investigated and determined to be in compliance for higher temperatures.

^b A capacitor operating at a temperature higher than indicated is not prohibited from being evaluated on the basis of its marked temperature rating, or when not marked with a temperature rating, is capable of being investigated to determine its compliance at the higher temperature.

37.2 The overcurrent protective device shall not open the circuit during the test.

37.3 The temperatures specified in Table 37.1 are based on an assumed ambient temperature of 25°C (77°F). A test is capable of being conducted at an ambient temperature within the range of 10 - 40°C (50 - 104°F), and the observed temperature corrected for a room temperature of 25°C (77°F).

37.4 The device is to be connected to a power supply at rated voltage by means of a 300 mm (12 inch) or greater length of Type TW, Type RH, or equivalent building wire. The lead-in wires are to be soldered to the blades. The wire size and type are to be determined using the appropriate value for the device's current rating from Table 310-16 of the National Electrical Code, ANSI/NFPA 70, as follows:

- a) Ampacities for copper conductors temperature rated at 60°C (140°F) for a receptacle rated 100 A or less for use on copper conductors only.
- b) Ampacities for copper conductors temperature rated at 75°C (167°F) for a receptacle rated greater than 100 A for use on copper conductors only.

37.5 The contacts of one outlet of the device are to be shorted together by means of a mating attachment plug inserted therein. The plug is to have rigidly attached solid blades, and the terminals of the plug are to be short-circuited by means of the shortest feasible length of Type TW, Type RH, or equivalent building wire. The wire size and type are to be determined using the appropriate value for the device's current rating from the National Electrical Code, ANSI/NFPA 70, as follows:

- a) Table 310-16 ampacities for copper conductors temperature rated at 60°C (140°F) when using solid copper jumper wires in testing a receptacle rated 100 A or less.

**UL COPYRIGHTED MATERIAL –
NOT AUTHORIZED FOR FURTHER REPRODUCTION OR
DISTRIBUTION WITHOUT PERMISSION FROM UL**

b) Table 310-16 ampacities for copper conductors temperature rated at 75°C (167°F) when using solid copper jumper wires in testing a receptacle rated greater than 100 A.

c) Table 400-5(A) or 400-5(B) ampacities for flexible cords and cables when using flexible cord jumper wires.

37.6 The test circuit is to carry the rated current of the overcurrent protector at the rated voltage. The test is to continue until stabilized temperatures are attained. A temperature is considered to be stabilized when three consecutive readings, taken at 5-minute intervals, indicate no further rise above the ambient temperature.

37.7 Temperature readings are to be obtained by means of thermocouples consisting of No. 28 - 32 AWG (0.08 - 0.032 mm²) iron and constantan wires. It is a common practice to employ thermocouples consisting of No. 30 AWG (0.05 mm²) iron and constantan wires with a potentiometer type of indicating instrument. This equipment shall be used when a referee measurement of temperature is required.

APPENDIX A

Standards for Components

Standards under which components of the products covered by this standard are evaluated include the following:

Title of Standard – UL Standard Designation

Attachment Plug Blades for Use in Cord Sets and Power-Supply Cords – UL 1659
Configurations, Wiring Device – UL 1681
Filters, Electromagnetic Interference – UL 1283
Fuseholders – UL 512
Fuses, Low-Voltage – Part 14: Supplemental – UL 248–14
Marking and Labeling Systems – UL 969
Circuit-Breaker Enclosures, Molded-Case Circuit Breakers, and Molded-Case Switches – UL 489
Plastic Materials for Parts in Devices and Appliances, Tests for Flammability of – UL 94
Polymeric Materials – Fabricated Parts – UL 746D
Polymeric Materials – Long Term Property Evaluations – UL 746B
Polymeric Materials – Short Term Property Evaluations – UL 746A
Polymeric Materials – Use in Electrical Equipment Evaluations – UL 746C
Secondary Protectors for Communication Circuits – UL 497A
Transient Voltage Surge Suppressors – UL 1449

No Text on This Page

***UL COPYRIGHTED MATERIAL –
NOT AUTHORIZED FOR FURTHER REPRODUCTION OR
DISTRIBUTION WITHOUT PERMISSION FROM UL***

April 30, 2003
Superseded requirements for
the Standard for
Current Taps and Adapters
UL 498A, First Edition

The requirements shown are the current requirements that have been superseded by requirements in revisions issued for this standard. To retain the current requirements, do not discard the following requirements until the future effective dates are reached.

7.1.1 (7.1.1) A device shall be legibly and permanently marked with:

- a) The company's name, trade name, or trademark or other descriptive marking by which the organization responsible for the device is able to be identified.
- b) The electrical rating. See also 7.3.1.
- c) The catalog number or an equivalent designation, where practicable.

Exception: The catalog number is not prohibited from appearing on the unit container when the product is too small, or where the legibility is difficult to attain, or where several catalog numbers use common parts.

7.1.1 effective until April 1, 2009

11.3.1 (11.3.1) The female face of a 2-pole, 3-wire (grounding) device of the 5-20R or 6-20R configuration, or a multi-configuration adapter that accepts attachment plugs with a 5-20P or 6-20P configuration, shall obstruct the insertion of a 2-pole, 3-wire (grounding) attachment plug of the 6-20P or 5-20P configuration, respectively, to the extent that the indicated devices cannot be mated by deliberate manual force including manipulation to deflect the ground pin to the outside of the face when attempting to insert the line blades.

11.3.1 effective until April 1, 2009

11.4.1 (11.4.1) The outlet face of a 2-wire, parallel-slot device of the 1-15R configuration, or a multi-configuration adapter that accepts attachment plugs with the 1-15P configuration, shall have a perimeter that encompasses an area equal to or larger than that indicated in Figure 11.4, and shall include an obstruction whose minimum size and location are indicated by the shaded portions of that figure. The obstructions shall be coplanar with the face or recessed by not more than 2.4 mm (3/32 inch). Devices having rigid bodies, materials having a minimum hardness of 90 when measured on the "A" scale of a Shore Durometer, having the indicated "A" dimension reduced to 13.5 mm (0.531 inch) meet the intent of the requirement.

11.4.1 effective until April 1, 2009

7.6.1 (7.6.1) An adapter having a grounding tab, lug, or similar device described in 16.1 – 16.3 shall be marked with the word "CAUTION," and the following or equivalent statement, "Connect tab to grounded screw." This marking shall be plain and legible on each adapter where visible during installation.

7.6.1 effective until April 1, 2009

Figure 11.3 (11.3)
Faces of outlet device showing location and minimum dimensions of obstructions

Figure 11.3 effective until April 1, 2009

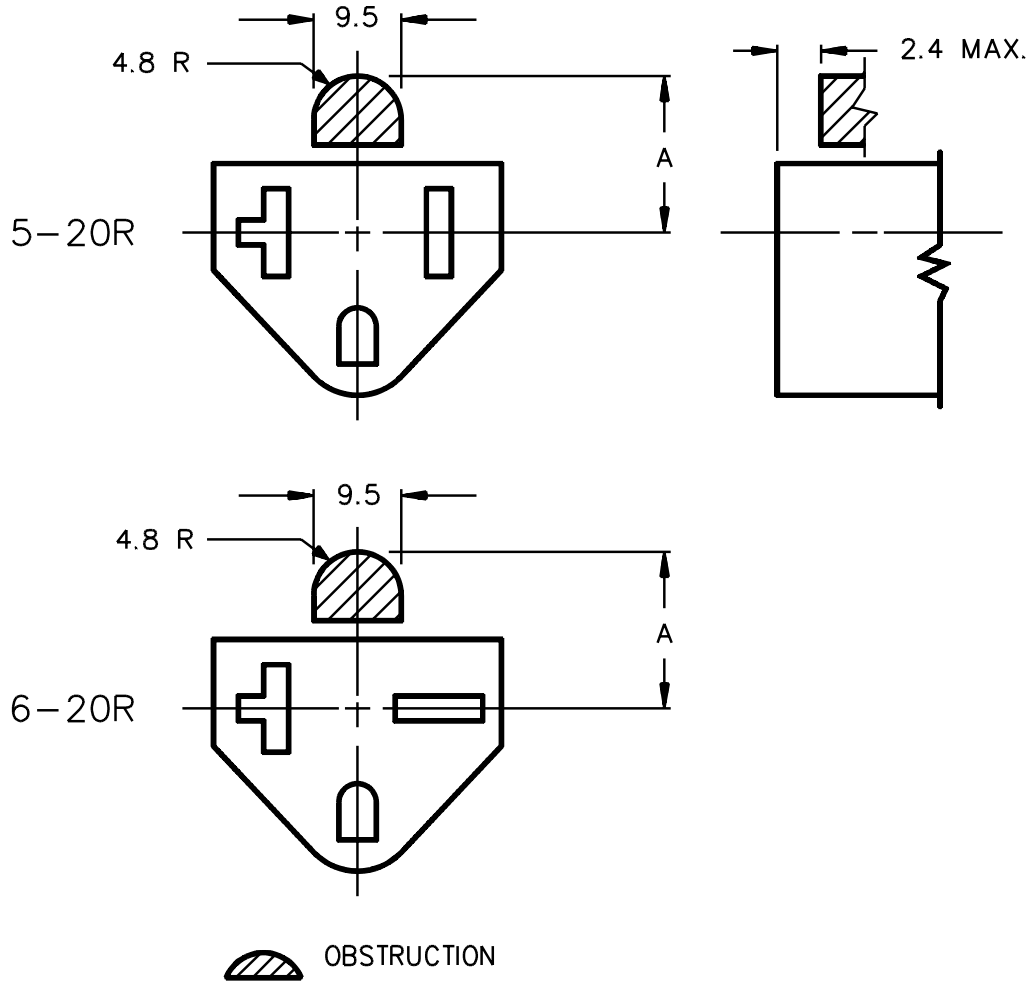

ALL DIMENSIONS IN MILLIMETERS

mm	2.4	4.8	9.5
inch	3/32	3/16	3/8

Dimension A mm (inch)	Shore durometer hardness (Scale A)
15.9 (0.625)	less than 90
13.5 (0.531)	90 or more

SB1947B

**UL COPYRIGHTED MATERIAL –
 NOT AUTHORIZED FOR FURTHER REPRODUCTION OR
 DISTRIBUTION WITHOUT PERMISSION FROM UL**

9.1 (9.1) A current tap shall employ blades on the line side only.

9.1 effective until April 1, 2009

9.2 (9.2) A current tap shall not accommodate more than three attachment plugs.

9.2 effective until April 1, 2009

9.3 (9.3) The requirement in 9.2 does not preclude a device in the form of an outlet multiplier for permanent attachment to a duplex receptacle rated 15 A at 125 V. This device is usually in the form of a current tap that has a permanent means of attachment to a duplex receptacle and is not prohibited from containing more than three outlets, provided:

- a) There are not more than three outlets per set of blades,
- b) When the device employs line blades of the 1-15 configuration, the line blades and contacts employ only the polarized construction.
- c) A means exists to provide electrical continuity between any flush plate and the plate-holding screw on the receptacle to which the assembly is attached.

9.3 effective until April 1, 2009

9.4 (9.4) The requirement in 9.2 does not preclude a current tap having six outlet receptacles and one set of line connections when the electrical use of the other outlet receptacle is effectively inhibited when mounted on or plugged into a duplex receptacle in any position.

9.4 effective until April 1, 2009

Table 18.1 (18.1)
Summary of tests – Current taps and adapters

Table 18.1 effective until April 1, 2009

Section	Test sequences	No. of devices ^a	Details
19	Comparative Tracking Index	5	Materials to be evaluated in accordance with Exception No. 1 to 10.3.1.
20	Glow Wire	3	Materials to be evaluated in accordance with Exception No. 1 to 10.3.2.
21	High-Current Arc Resistance to Ignition	3	Materials to be evaluated in accordance with Exception No. 2 to 10.3.2.
24 22 24	Dielectric Voltage Withstand Mold Stress Relief Dielectric Voltage Withstand (Repeated)	6	All devices. Devices employing thermoplastic materials. Devices subjected to Mold Stress Relief Test.
23	Moisture Absorption Resistance	3	Conducted on vulcanized fibre, fuseholders and insulating backplates. Use insulating material portion of device only.
25	Accelerated Aging	6	Materials to be evaluated in accordance with the Exception to 10.4.1.

**UL COPYRIGHTED MATERIAL –
NOT AUTHORIZED FOR FURTHER REPRODUCTION OR
DISTRIBUTION WITHOUT PERMISSION FROM UL**

Table 18.1 (18.1) Continued on Next Page

Table 18.1 (18.1) Continued

Section	Test sequences	No. of devices ^a	Details
27	Security of Blades		Devices rated 15A or less and 250 V or less.
26	Insulation Resistance	6	Conducted on devices molded of rubber or similar materials, or any material containing enough free carbon to render the material grey or black.
27	Security of Blades	6	Devices rated 15 A or less and 250 V or less that are not subjected to the Accelerated Aging Test.
28	Contact Security	6	Devices with 1-15P configuration blades only.
29 30 31 32 33	Retention of Plugs Overload Temperature Retention of Plugs (Repeated) Resistance to Arcing	6	Devices with 1-15R, 5-15R, 5-20R, 6-15R, and 6-20R configurations. Devices with 1-15R, 5-15R, 5-20R, 6-15R, and 6-20R configurations. Required only for devices with 1-15R, 5-15R, 5-20R, 6-15R, and 6-20R configurations. Not required for devices employing phenolic, urea, or melamine in the outlet face.
34	Fuseholder Temperature	6	Devices with fuseholders only.

Table 18.1 Continued

Section	Test sequences	No. of devices ^a	Details
35	Improper Insertion	12	Devices with 1-15R outlet face configuration only.
36	Grounding Contact	6	Devices intended for fixed installation on receptacles employing 5-15R, 5-20R, 6-15R, 6-20R, 7-15R, 14-15R, or 15-15R configurations only.
37	Reserved for future use		

^aA set of representative devices is capable of being used for more than one group of tests when agreeable to all concerned.

No Text on This Page

***UL COPYRIGHTED MATERIAL –
NOT AUTHORIZED FOR FURTHER REPRODUCTION OR
DISTRIBUTION WITHOUT PERMISSION FROM UL***